

# Ready to build an **AI project** around **Mechanical Engineering**?



From **predictive maintenance and robotics** to **simulation and advanced manufacturing**, AI is transforming how engineers design, build, and optimize machines.

With expert mentors from global tech companies, students build real AI tools at the intersection of **mechanical engineering, robotics, and advanced manufacturing.**



## Why Delta AI?



### OUTCOMES





- ➔ **A standout project for your college application**  
Admissions officers look for initiative and depth. An AI project in mechanical engineering shows both.
- ➔ **A meaningful academic story tied to your passion**  
Your project becomes something you can write about, talk about in interviews, and be proud to present.
- ➔ **Real skills that set you apart**  
Learn the same AI and data skills behind careers in mechanical engineering, robotics, manufacturing, and design.
- ➔ **Inspired by real innovation in engineering and manufacturing**  
Work on ideas used by real engineers and companies, adapted for your level.
- ➔ **A recommendation letter that carries weight**  
Your mentor writes a detailed letter speaking to your skills, growth, and work ethic.

### STRUCTURE

**AI Intensive** 5-week cohort program

**AI Immersive** 25 hours of 1:1 mentorship

#### Students receive:

-  **Hands-on learning** with step-by-step guidance
-  A curriculum **built around your level**
-  A mentor **recommendation letter**
-  A **project white paper** documenting your work

Students work with mentors from leading tech companies driving the AI revolution.



## Who Is This Built For?



Engineering-curious students



Students aiming for top college applications



Both beginner and advanced learners



Students looking for 1:1 or cohort mentorship

# Applications of AI in Mechanical Engineering



AI is reshaping mechanical engineering from **smarter designs** to **self-optimizing machines**.



AI is powering the next generation of machines. Don't just study it, engineer with it.

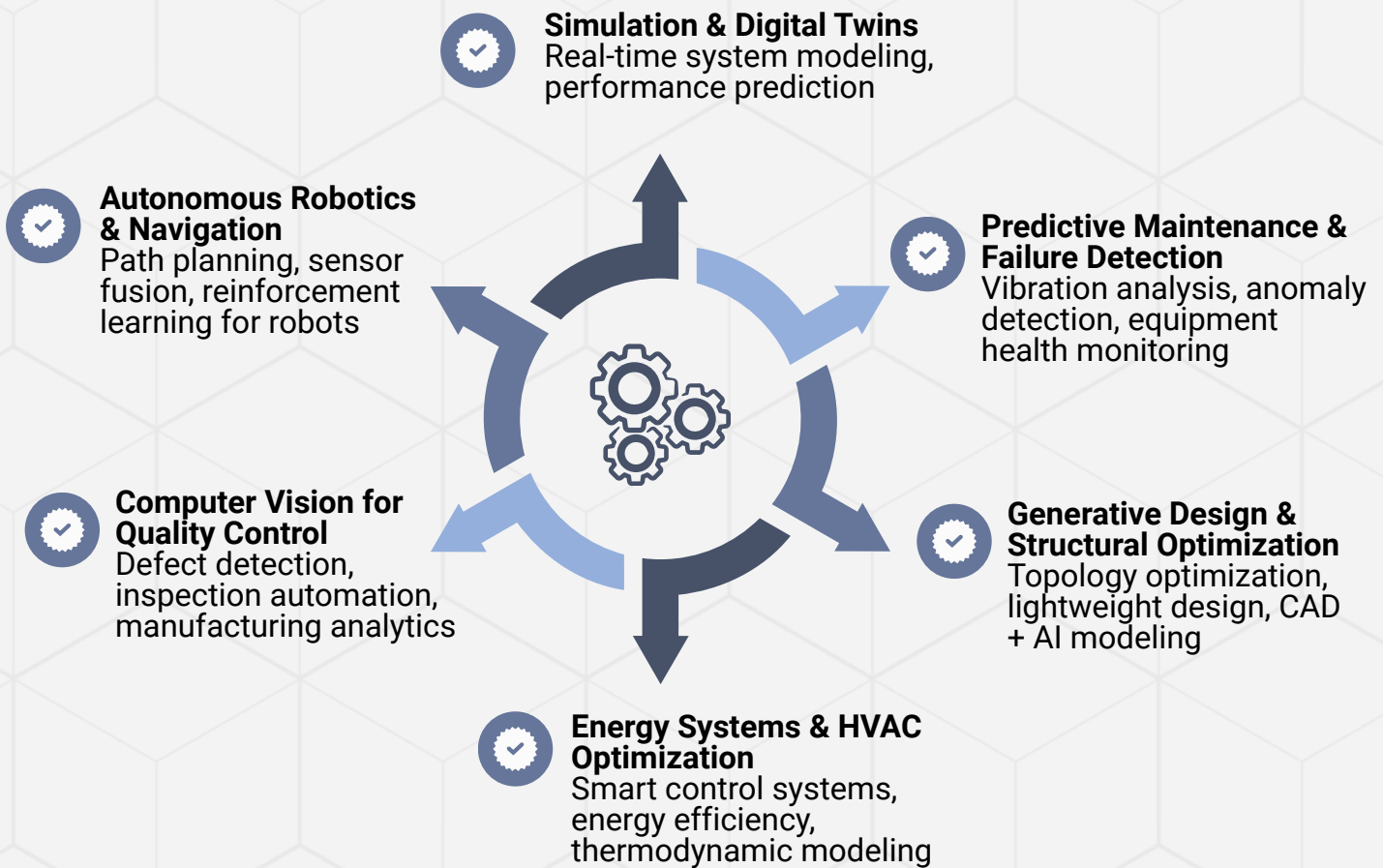

See portfolio-ready AI x Mechanical Engineering projects students build with Delta AI



# Energy Consumption Optimization for HVAC Systems

A smart control system that optimizes HVAC energy consumption while maintaining comfort, using data, control models, and learning algorithms. The same kind of approach used in smart buildings and modern energy management systems.



## Skills demonstrated

- Control systems & optimization
- Machine learning for energy systems
- Thermodynamics & system modeling
- Data analysis & pattern recognition





## Real-world outcome

Students build AI systems that make buildings smarter and more energy-efficient, real-world tech used in smart cities and sustainable engineering.



## Built with

-  Python (scikit-learn, TensorFlow)
-  Building & energy datasets
-  Data Visualization



## Your deliverable

Portfolio ready live project, white paper, and public GitHub repo



## Predictive Maintenance System

A real-time monitoring system that predicts equipment failures using sensor data like vibration, temperature, and sound. The same kind of technology used in factories and Industry 4.0 systems to prevent breakdowns before they happen.

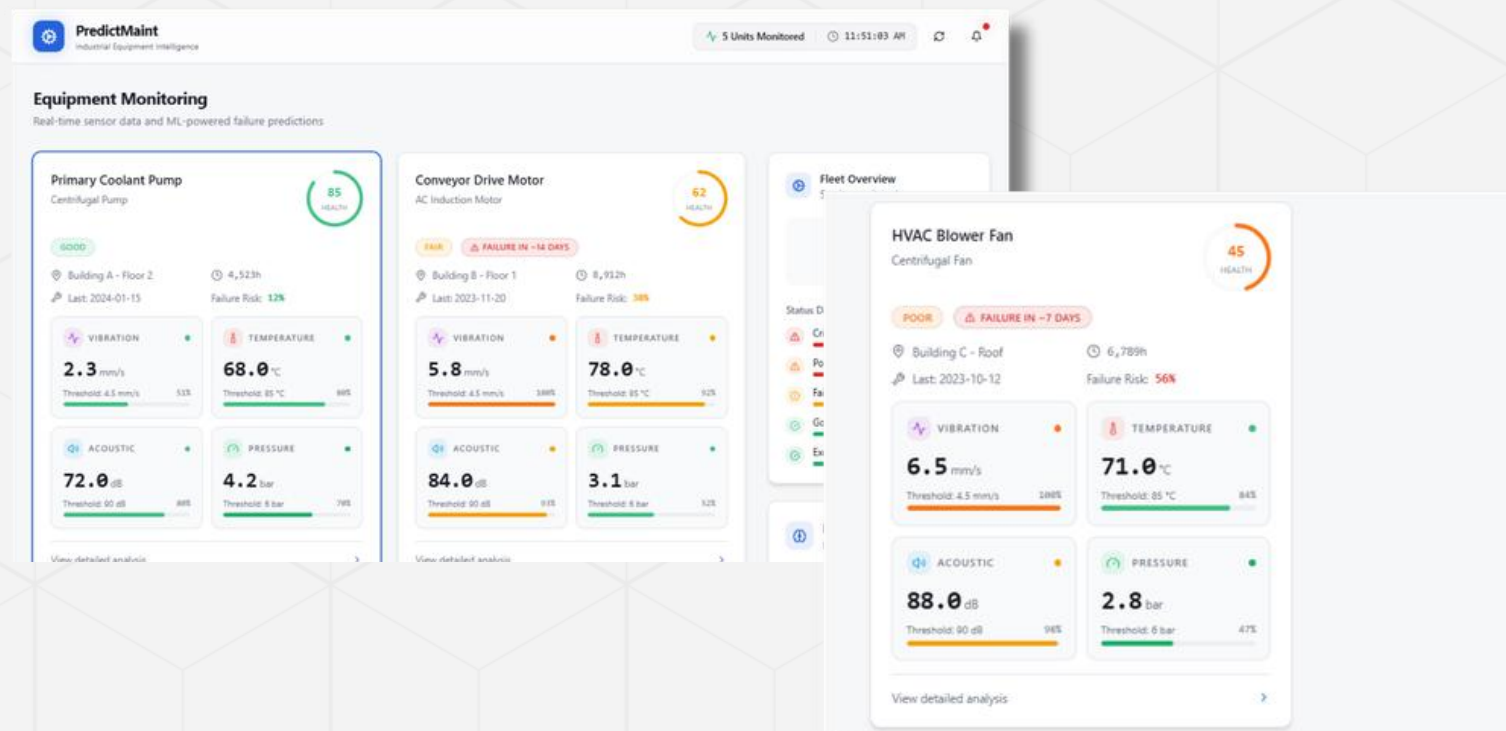

### Skills demonstrated

- Time-series analysis & forecasting
- Signal processing & sensor data analysis
- Machine learning for anomaly detection
- Real-time monitoring & dashboards



### Real-world outcome

Students build predictive maintenance systems like those used in modern factories, showing you can solve engineering problems with AI.



### Built with

- Python (scikit-learn, NumPy)
- NASA bearing data
- Plotly Dashboards



### Your deliverable

Portfolio ready live project, white paper, and public GitHub repo



# Generative Design for **Structural Optimization**

A generative design system that creates optimized mechanical structures based on constraints like weight, strength, and material cost, producing efficient, high-performance designs.

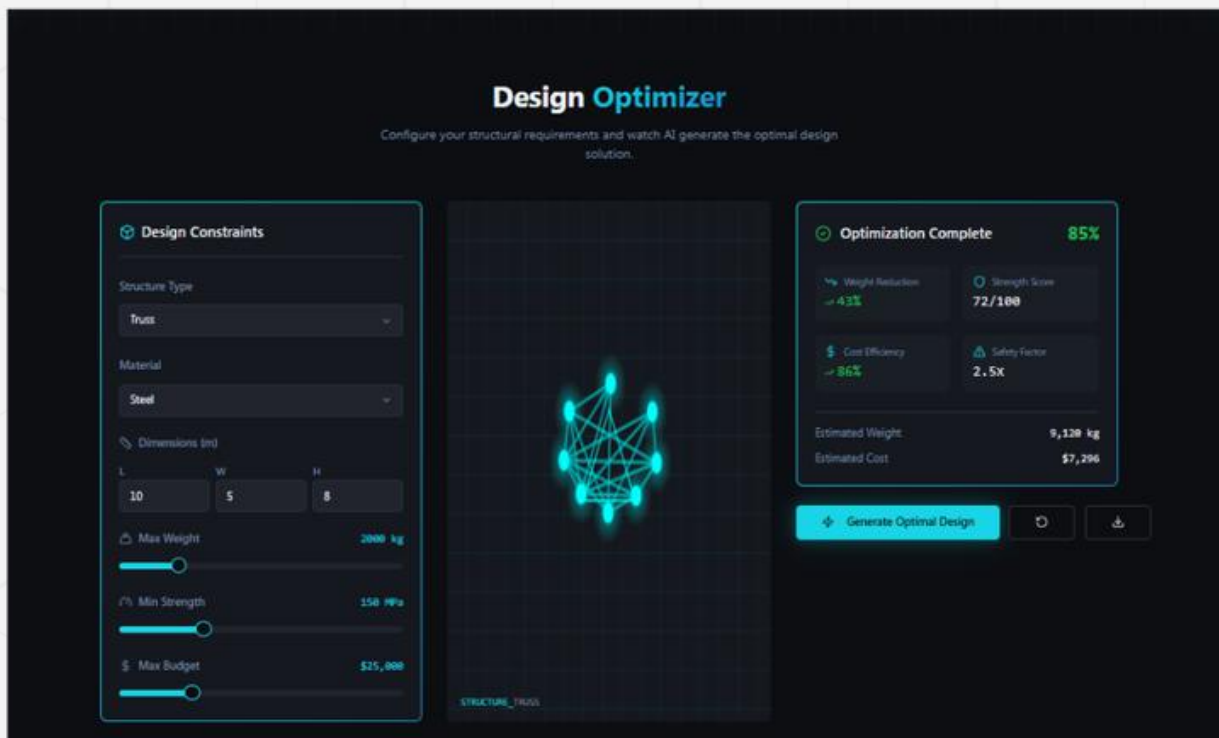

## Skills demonstrated



- Generative algorithms & optimization
- CAD & 3D modeling
- Finite element analysis (FEA)
- Engineering design thinking

## Real-world outcome



Students build advanced design tools that engineers use to create lighter, stronger, and more efficient structures.

## Built with



- Python
- CAD tools (FreeCAD, STL/STEP files)
- Simulation & analysis

## Your deliverable



Portfolio ready live project, white paper, and public GitHub repo

## Autonomous Robot Navigation

An autonomous robot navigation system that learns to move through environments using sensors and reinforcement learning, visualizing paths and decisions in real time.

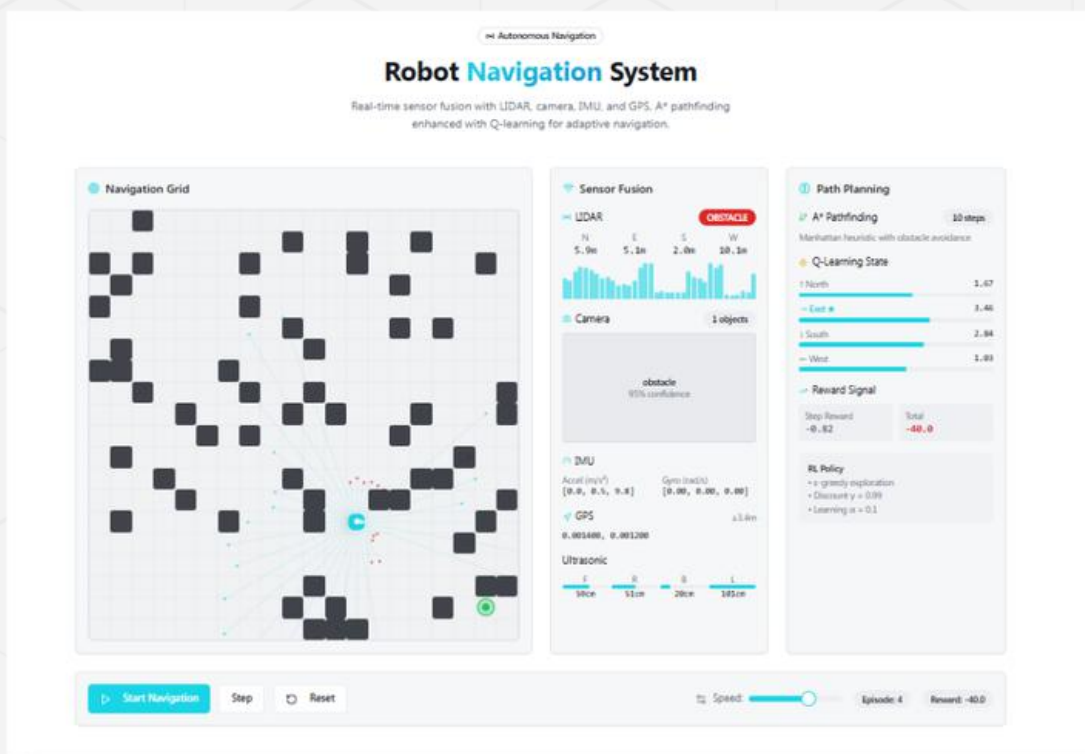

### Skills demonstrated



- Reinforcement learning
- Robotics & sensor fusion
- Computer vision
- Spatial reasoning & navigation



### Real-world outcome



Students work on real-world robotics challenges similar to those addressed in self-driving and autonomous systems, one of the strongest projects for demonstrating technical depth on a college application.

### Built with



-  Python (ROS, OpenCV)
-  Gazebo
-  LiDAR, cameras, IMU

### Your deliverable



Portfolio ready live project, white paper, and public GitHub repo

# Program Structure: AI Immersive (1:1)



AI Immersive offers **25 hours of 1:1 mentorship** from an industry expert. Most students complete it in **10-12 weeks**.

## A Learning Experience Built Around You

- Learn at your own pace with flexible scheduling.
- All ages welcome - middle school through adult learners.
- Every skill level - from your first line of code to advanced projects.

### THE JOURNEY



#### ONBOARDING & MENTOR MATCHING

We pair you with a mentor who aligns with your interests, timezone, and project goals. The kickoff includes orientation and an initial project discussion and brainstorming!



#### PERSONALIZED GOAL SETTING & CURRICULUM

Your mentor defines clear learning outcomes, maps weekly milestones, and builds a personalized curriculum tailored to your experience level.



#### FOUNDATIONAL LEARNING

Learn essential AI concepts, tools, and techniques through hands-on, mentor-guided sessions covering Python, Data Handling, and ML Model basics.



#### PROJECT BUILD

Apply your skills to develop a complete AI project with technical guidance, troubleshooting support, and iterative improvements from your mentor.



#### PRESENTATION & EXPERT REVIEW

Present your completed project for expert evaluation and receive detailed feedback with a roadmap for next steps.



#### REFERRAL LETTER & NETWORKING SUPPORT

Students who complete the program and complete the project receive a mentor-endorsed letter for college or internship applications.

### Support Beyond Sessions

- ✉ After-hours email and chat support from mentors.
- 📱 Messaging, Scheduling Sessions via CrimsonApp.
- ⏸ Ability to Pause program during busy times (exam season etc).
- 🏠 Be part of Delta AI Discord Community.

# Program Structure: AI Intensive (Cohort)



Five weekends. Two real AI projects.  
One portfolio that sets you apart.

## PROGRAM FORMAT

- 14 hours of live, instructor-led group learning
- 2 hours of exclusive 1:1 mentorship
- Unlimited Teaching Assistant support via Discord
- Demo Day showcase to close the program

## THE JOURNEY



### WEEK 1 | SET UP + SHIP YOUR FIRST AI APP

Set up Python and your development environment. Build and customize an AI chatbot. Publish your first project on GitHub.



### WEEK 2 | EXPLORE AI + DEFINE YOUR PROJECT

Learn how AI processes language and images. Enhance your chatbot with new AI capabilities. Choose your interdisciplinary project topic.



### WEEK 3 | REFINE + PREPARE

Improve your project with mentor feedback. Learn to present technical work clearly. Begin your 1:1 mentorship sessions.



### WEEK 4 | BUILD YOUR AI PROJECT





Develop an AI tool in a field you care about. Work with mentors to build a functional prototype. Use real data and practical tools.







### WEEK 5 | LAUNCH + DEMO DAY

Deploy your project as a live website. Finalize deliverables with mentor support. Present your work at Demo Day.

## WHAT YOU'LL WALK AWAY WITH

-  Two AI projects aligned to your interests
-  Live website or shareable demo links
-  Public GitHub repos
-  Slide deck, demo video, and short white paper
-  Certificate of completion and mentor recommendation letter

## Support Beyond Sessions

-  After-hours email and chat support from mentors.
-  Messaging, Scheduling Sessions via CrimsonApp.
-  Ability to Pause program during busy times (exam season etc).
-  Be part of Delta AI Discord Community.

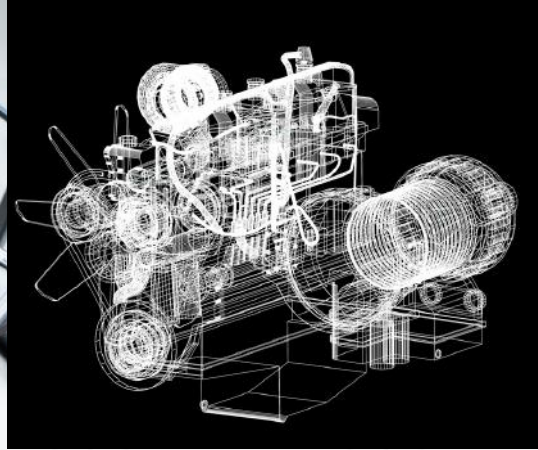
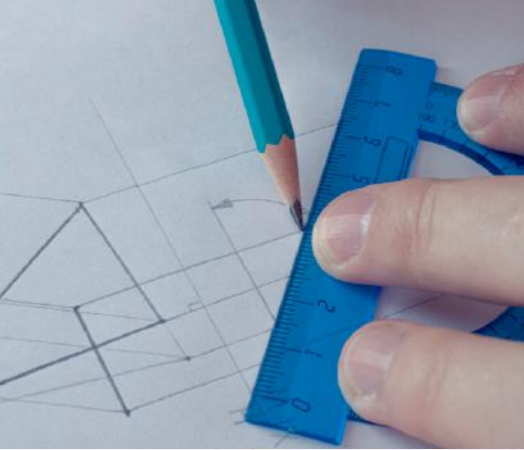

# Ready to Build Your Own **AI x Mechanical Engineering Project?**



**REGISTER YOUR INTEREST**

### **Hayato M.**

*Delta AI Immersive Alumni, Project: Neural Fold*

"I never thought I could create a project that **integrates my culture and AI**. This experience has opened new doors for me."



### **Aysel B.**

*Delta AI Intensive Alumni, Project: Nananet Chatbot*

"The Delta AI program was an **incredible experience fast-paced, engaging, and perfectly structured**. I loved how each session built on the previous one, **making even complex AI concepts feel achievable.**"



**Learn from the best!**



Not into Mechanical Engineering?  
**Explore AI projects in other fields too.**

**Business | Finance**

**Music | Fine Arts**

**Biology | Medicine**

**Environment | Sustainability**

**Law | Public Policy**

**And Many More!!**