

Escape Velocity



SPACE COAST REGION
PORSCHE CLUB OF AMERICA

2022/1



Roads end. Driver never stops.

A full-throated 473 hp. A 0 to 60 time of just 3.7 seconds. Countless customization options and an interior enhanced with innovative driver tech. Get in the driver's seat and discover a sedan with everything, except compromises.

Experience the Panamera GTS.



Porsche Melbourne
509 East NASA Blvd.
Melbourne, Florida 32901
Tel. 321-216-2930
porschemelbourne.com

© 2022 Porsche Cars North America, Inc. Porsche recommends seat belt usage and observance of traffic laws at all times. European model shown. Some options may not be available in the U.S.



PORSCHE



President's Column

Deja Vu all over again! So here we are 10 years later and I am back in the position I so much loved 10 years ago. This club is very special to me and I take being your President very seriously. My wife, and your prior President Robin and I think of this club and the members as an extension of our family! We have met so many great friends over the years and I hope to keep expanding that base this year. My primary focus will always be to keep this club as the best in all of PCA. As we get back to normalcy, please let me know if you have any ideas for new events, or want to revisit an event we did years ago, as we are always looking to add events to the calendar. Also, if you have any concerns/comments/suggestions, feel free to contact me at any time.

That being said, we are going to resume having open meetings for all club members. The first will be held on March 19th, but that has most likely already occurred. I hope you were there, had a great time and participated in ideas going forward. If you didn't make it, watch for the next one and please join us. The more ideas and input we get, the higher the quality of the product we can deliver.

Now for the business part of the message. A huge thank you to my wife Robin for leading this club the last two years through some extremely tough times. She and her leadership team did a great job! Special thanks to outgoing Past President Carmen DeVito, Secretary Scott Kee, and our award-winning Webmaster Jeff Dorman for their long-term roles in the success of the club. Carmen and Scott will still be around filling critical positions in the future success of the club. Jeff has done a tremendous job running our website for years but is stepping down to take a break and going to go play with his new Italian F-car for a while. Don't worry, we will get him back one day!

I also want to thank our new leaders for stepping up and getting more involved in the club's future success; Ed Springer as Secretary, Jurgen Schwanitz transitioning to Webmaster and Steve Tarr who will be working on Special Events. If you went to the New Member Social (an event he lead the charge on), you probably met Steve and saw what a great asset he is to our Club.

Lastly, I want to thank our primary sponsor Porsche Melbourne and Shay Rowe specifically. Shay supports us in so many ways and this club would not be as successful as it is without his continued support. I also want to thank the American Muscle Car Museum. Mark Pieloch and his world class staff have also supported us over the years in numerous ways and our autocross program is the envy of every other region in the country. Thanks to all of our advertisers for their continued support through some rough times the last two years. We appreciate you sticking with us and I challenge our members to utilize their services whenever you get the chance.

As always, check the calendar for the latest events, circle a few and join us. The important thing is to get out there, drive those cars and meet like-minded people!

Steve Hoffman

President Space Coast PCA

In This Issue

From the Editor	page 4
Our Officials	page 5
Membership Corner	page 6
Porsches and Pups	page 7
Keeping the Pedal to the Metal	page 8
DE Tech Session	page 9
Kaffeeklatsch	page 10
Larry Wilson Collection	page 11
New Member Social	page 12-13
Roar Before the 24	page 14
IMSA Pilot Challenge	page 15
Rallye Daytona	page 16
The Rolex	page 17
Member Spotlight	page 21
Autocross Report	page 22-23
Space Coast Classifieds	page 24
Confessions of a Porsche Wife	page 25
Porsches and Polo	page 26-27
Tech Spotlight	page 28
Gathering of the Faithful	page 29
Coast to Coast Porsche Adventure	page 30
Porsches and Pistols	page 31
Werks Reunion	page 32
Space Coast Junions	page 33
Coming Attractions	page 34



Mark your calendars and save the date. June 12-18, 2022 in the Poconos

PORSCHE CLUB OF AMERICA

On the Cover: Ed Springer's 914. Photo by Ray Baldino.

From the Editor

Bring on 2022! It's already looking better with lots of activities planned for our Space Coast Club. Lots of fun to look forward to, especially Zone Fest over Memorial Day Weekend, a special event that we are sponsoring for the entire Zone 12. There will be a Concours, Rally, Dine and Drive, Auto Cross, dinners and get togethers just to name a few.

Many thanks to all our Advertisers and to Porsche Melbourne for supporting our Club. Welcome to our new advertiser, G&T Real Estate Services, owned and operated by Robert and Christine Geiger, who are also new Space Coast Porsche members. Be sure to introduce yourselves if you run into them at one of our events.

I can't thank those of you enough that helped with this issue by taking beautiful pictures, and volunteering to write articles about your Porsche experiences. I know you'll all enjoy them and hope that they will encourage more of you to share your stories. It takes a village you know.

One sad note to announce is the passing of Vic Elford who passed away this month at the age of 86. Vic was an accomplished race car driver, fondly referred to as "Quick Vic" and we were fortunate to have had him as the speaker at our 50th Anniversary Celebration a few years ago. He graciously entertained us with many tales of his varied racing career.

Let's make 2022 a great year for our Club. Get out there and you'll be amazed and how much fun you'll have meeting new members and making new friends.

Sue Kee



EV Editor
Sue Kee
suekee.ev@gmail.com
321.431.6429

Got Something to Say?
Please send your Porsche stories and photos to Sue Kee at suekee.ev@gmail.com

Please check out our new and revamped website spc.pca.org (do not use the www) and new facebook page at www.facebook.com/SpaceCoastRegionPCA



Memorial Day Weekend 2022

Featuring the American Muscle Car Museum

- Concours on the beautiful grounds
 - Tour & Dinner inside the incredible AMCM - 340+ cars (including 44+ Porsches)
 - Autocross with 1/8-mile dragstrip, skidpad, and road course all in one
 - Gimmick Rally and Driving Tours
 - Friday night Cocktail Party/Dinner at Porsche Melbourne
 - Sunday night Banquet at Eau Gallie Yacht Club
- Zonefest 2022 sponsored by Porsche Melbourne and the American Muscle Car Museum

Registration to open April 1, 2022



PCA members make a difference in their community!

Every year across Porsche Club of America, members are making a difference with many amazing, heartwarming, and thoughtful acts of kindness. PCA is continually collecting stories of member's community contributions, and publishing articles for all to read in an effort to highlight what our club is doing and inspire other regions to help in their own way.

READ ALL OF THE HEART-WARMING MEMBER STORIES:

www.pca.org/members-making-difference

OR SUBMIT YOUR REGION'S CONTRIBUTION:

www.pca.org/contact-members-making-difference



**PORSCHE CLUB
OF AMERICA**

Our Officials *and Leadership*



President
Steve Hoffman
steve1rob2@aol.com
321.652.4654



Vice President
Cindy Hambidge
hambidgec@bellsouth.net
321.298.0830



Secretary
Ed Springer
Springer933@gmail.com



Treasurer
Robert DeVries
rdevries@
firstwavefinancial.com
321.773.7773



Immediate Past President
Robin Hoffman
robinchoffman@hotmail.com
321.543.9205



North Region Coordinator
Milt Weisman
milt.weisman@gmail.com
814.577.9988



South Region Coordinator
Sean Salthouse
seanwsalthouse@gmail.com
772.501.6644



Membership Chair
Vicki Hempel
vickidog22@gmail.com
631.463.1095



Social Chair
Sally Jecmen
touchlightsal@yahoo.com
321.537.3605



Social Media Chair
Ryan Gorsuch
thomasgorsuch@yahoo.com
321.258.5401



**Dealer Liaison/
DE/AutoX Co-Chair**
Ken Marshall
kmarshall1@cfl.rr.com
321.750.2096



Touring Chair
Steve "Wojo" Wojcicki
wojo@cfl.rr.com
321.454.7612



Tech Chair
Rob Van Name
robertv8890@att.net
321.243.3393



Off Road Chair
Ron Menck
rmenck@icloud.com
321.243.5356



Charity Chair
Rachel Henry
rachelnhsch@gmail.com
772.913.2533



Events Chair
Scott Kee
dskee@cfl.rr.com
321.431.6428



AutoX Co-Chair
Carmen DeVito
csdred997tt@gmail.com
610.314.8851



Special Events Chair
Steve Tarr
stephendtarr@gmail.com
610.742.7878



Webmaster
Jurgen Schwanitz
928s@att.net
772.643.5162



Space Coast Badges
Elissia Bennice
tcbean@yahoo.com
518.257.0522



Rally Master
Brian Reinert
breinert@cfl.rr.com
321.298.0089

Advertising Rates

Call Sue Kee at 321.431.6429
or email her at suekee.ev@gmail.com

	Yearly Prepaid
Full Page	\$1000
Half Page	\$700
Quarter Page	\$350
Business Card	\$200

Membership Corner

by Vicki Hempel

Welcome all new members and transfers!! We have 1072 primary members and 443 affiliate members for a total membership of 1515. A fun way to meet members is to attend one of the kaffeeklatsches (Cars & Coffee) at three locations monthly.

Central Area – First Saturday of the month from 9am to 11am Panera Bread, 4100 N Wickham Rd, Melbourne, FL. South Area – Second Sunday of the month from 9am to 11am. Panera Bread, 2001 Indian River Blvd, Vero Beach, FL. North Area – Third Sunday of the month

from 9am to 11am Jason's Corner, 135 Canal Street, New Smyrna Beach, FL. No need to RSVP – just come on out and bring your Porsche! We spend most of our time in the parking lot visiting where there is lots of room to social distance.

For more information regarding the kaffeeklatsches and a complete list of events go to our website calendar <https://spc.org/calendar/> and Facebook events Space Coast PCA. We hope to see you at one of the events!!

Welcome to our New Members!

December 2021

Stephan Dembinsky - 2022 911 Carrera
Elissa Dubberly - 2020 Macan
Peter Zurcher - 2017 911 Carrera
Sammie Foster - 2013 Boxster
Chuck Yates - 2020 718 Cayman GT4
Tim Davis - 2015 911 Carrera Cabriolet
William Bragg - 2007 91 Carrera
Stuart Amois - 2004 911 40th Anniversary
Merrill Willett - 2016 Boxster

Transfers In:

Stephen Martin from Carolinas - 1972 914
Richard & Debbie Hudgins from First Settlers - 2005 911 Carrera S
Christopher Shelli from Bluegrass - 2018 718 Cayman
Chris Barreras from Chesapeake - 1999 Boxster
Evan & Jeffery Duncan from Florida Crown - 1999 Boxster

January 2022

Spencer Propper - 2018 911 GT3
Michael Mclain - 2015 911 Carrera
Mark Thornton - 2005 Boxster
Lee Weigle - 2006 911 Carrera S
Kevin Shea - 2022 718 Cayman
Kenneth Meertens - 2014 911 Turbo
Mark Pulliam & Aubrey Harris - 2017 911 Carrera
Mark Reagan - 2008 Boxster
Michael O'Brien - 2022 718 Boxster
Graham Smith - 2022 Taycan
Matthew Aberbach - 2021 Macan
Kylie Johnson - 2021 Macan
Wendy Carey - 2021 718 Cayman
Catherine Simon - 2021 Macan
Roger Lynch - 2022 911 Carrera
James Kincaid - 2022 911 Carrera
Anita Carbone - 2021 Macan
Michelle Randone - 2020 Macan
Hongwei Dai - 2021 Macan
Owen Pruchnowski - 2021 Macan
Nancy Stanifer - 2021 Macan
Richard Conforti - 2021 Macan

Cindy Ziade - 2022 Macan
Dawn Johnson - 2022 911 Carrera
John Murphy - 2021 Macan
Gwendoline Harris - 2021 Macan
Aleksandr Fedorov - 2022 Cayenne
Joseph Barro - 2022 Taycan
Kristen Marquez Blacketer - 2021 Taycan
Linda Adams - 2022 Panamera
Zaida Rios - 2020 911 Carrera
Benjamin Nace - 2021 Macan
Peter Worthy - 2016 911 Carrera
Robert & Christina Geigner - 2006 911 Carrera
Donald & Beverley Chisholm - 2012 911 Turbo
Christopher & Michelle Wainwright - 2005 911 Carrera
Vivek Kumar - 2008 911 Turbo Cabriolet

Transfers In:

Christopher Reed & Barbara Holder from Arizona - 2015 Cayman GTS
Lee Weigle from Potomac - 1972 911E
Melodi Shoemaker from Florida Crown - 2006 Boxster
Robert Christopher Wood from Wichita - 2008 911 Carrera
Alex Harber from Alabama - 2007 Cayman S

February 2022

Jim Mason - 2015 Cayman
Whitney White - 2020 Macan S
Jonathon Mossler - 2020 911 Carrera
Michael Degiglio - 2019 911 GT3 RS
Jayce France - 2004 911 Turbo
Richard Groesz - 2003 Cayenne
John Swatek - 2022 911 Carrera S
Timothy Hill - 2021 Macan
Kirit Patel - 2022 Taycan
Jason M. Kempf - 2022 911 Carrera
T.J. Lane - 2021 Taycan
Thomas Switzler - 2019 Cayenne
Todd Brady - 2022 718 Cayman GTS 4.0
Daniel Maskevsky - 2001 911 Carrera 4
Barry Boatner - 2000 911 Carrera Cabriolet

Janice Austen - 2016 911 Carrera
Joseph Killian - 2020 911 Carrera
John Taylor - 2022 Macan
Kathleen MacMahaon - 2022 Macan
Phillip Lane - 2022 Cayenne GTS
Jennifer Morgan - 2022 Panamera
Peter Woods - 2022 Panamera
Rita Aker - 2021 Cayenne S
Pimnapat Wattanasuk - 2022 Cayenne GTS
Skip Hardy - 2019 Macan S
Molly Teter - 2022 Cayenne
Brandon Smith - 2022 Taycan
Douglas McCormack - 2021 718 Boxster
Thomas Caldwell - 2018 911 Carrera GTS
John Weidenhammer - 2016 911 Carrera
John Balrup - 2018 Macan
Jorge Mino - 2018 718 Cayman
Thomas Caputo - 2021 Macan
Deatra Farmer - 2021 Macan
Sandra Weimann - 2018 Macan
John Klein - 2020 Macan
Richard Collins - 2017 Macan GTS
Albert Vassallo - 2019 Macan
Lillian Cobb - 2022 Macan
Nicole Vuyovich - 2020 Macan
Aaron Royer - 2022 Taycan
Lauren Roberson - 2022 Taycan
Josette Miller - 2022 Taycan
Andrew Lunn - 2022 Taycan
Dana Andersen - 2021 Taycan
Merlyn Mcfadden - 2022 718 Cayman
John Shanks - 2022 718 Cayman
George Roma - 2017 911 Carrera
Alexandra Davis - 2022 911 Carrera
Harold Levy - 2020 911 Carrera S
Patti Hall - 2022 Macan
Douglas Person - 2022 Macan
Grace Couture - 2022 Macan
Jeff Fair - 1988 944

Transfers In:

Daniel Maskevsky from Florida Crown - 2001 911 Carrera 4
David Carlson from Jersey Shore

Porsches and Pups Charity Event

Article and photos by Cindy Hambidge

Space Coast members were invited to participate in a special a charity event at the American Muscle Car Museum (AMCM) hosted by the Citrus PCA Region. On Saturday January 8, 2022 we met at the Panera in Melbourne for our Kaffeeklatsch then set out for the AMCM. It's always a treat to tour the incredible, private car collection of Mark Pieloch in Melbourne. More than 100 people attended to view this amazing collection and were treated to a fantastic tour lead by

Mark. He told many interesting, and some comical, stories about the amazing cars in his collection and how he acquired them. Thanks to AMCM for being such gracious hosts.

The beneficiary of this wonderful event was the Southeastern Guide Dog Society who raises and trains pups for a noble cause – helping the vision impaired and others with special needs. This is a cause close to my heart because my husband was legally blind. More than \$4300 was raised.



WERKSHOP

321-724-2059

Independent Porsche Specialist

WWW.WERKSHOP.BIZ

**7660 INDUSTRIAL RD.
WEST MELBOURNE, FL**

Keeping the Pedal to the Metal

A Snapshot of What's Happening in the Space Coast Region PCA

Details – Details – Details

Complete information about each event can be found on our Space Coast PCA Website and Space Coast Facebook.

<https://spc.pca.org/calendar> – click on the event for more information.

Please refer to the most up to date calendar on our Space Coast Website: <https://spc.pca.org>.

KaffeeKlatch (Cars and Coffee)

We continue to have 3 informal get-togethers each month 9 am to 11 am to enjoy breakfast, coffee and our biggest passion – Porsches! Please join us at any or all the Kaffeeklatches.



One in Daytona, Melbourne and Vero Beach
Come out to one or all – it's always a good time!
No pre-registration needed, just show up.

First Saturday of the month – Melbourne KK at Panera Wickham Road, 9 am

Second Sunday of the month – Vero KK at Panera, 9 am

Third Sunday of the month – Daytona KK at Jason's Corner in New Smyrna, 9 am

Space Coast Events

2022 AX Events at American Muscle Car Museum

April 16 – AX at the AMCM, 7 am

May 7 – AX at the AMCM, 7 am

September 17 – AX at the AMCM, 7 am

October 1 – AX at the AMCM, 7 am

December 3 – AX at the AMCM, 7 am

Porsche vs Corvette Challenge
Date TBD in the Fall

PCA Juniors

**It's not just the cars...
and now it's not just the grown-ups!**

With our new PCA Juniors program, PCA is about the kids too! The PCA Juniors program has been created so kids can enjoy PCA events, learn about Porsches and build the enthusiasm that runs through all of the Porsche Club of America.

PCA Juniors is a program for Porsche enthusiasts under age 18. Participants must be registered by an active PCA member. Join here at <https://www.pca.org/pca-juniors>.

If you would like to order a free PCA Juniors shirt, please contact Robin Hoffman robinchoffman@hotmail.com with name and shirt size for your "Junior".

Be Sure To Save These Dates

April 22 to 23 – Wheels and Keels at The Moorings, Vero Beach

May 27 to 30 – Zone Fest hosted by Space Coast, sponsored by Porsche Melbourne and the American Muscle Car Museum

June 12 to 18 – Porsche Parade at Kalahari Resorts, Pocono Manor, PA



COBIA
INSURANCE

HOME AUTO BUSINESS FLOOD

(321) 914-0808

www.COBIAINSURANCE.com



YOUR INSURANCE IS OUR BUSINESS!

Fourth Annual Zotz Racing HPDE Tech Event

Article by Scott Kee
Photos by Sue Kee

Ten cars from the Space Coast did the drive for the 4th Annual Zotz Racing HPDE Tech Event on Saturday on January 15th at their facility on 6625 Edgewater Drive in Orlando. Ron and Eric Zitza provided coffee and donuts for all to enjoy and invited vendors to help answer your questions about the many different products on display. Lots of door prizes added to the fun. Kevin Duffy was on site again this year to explain to beginners how to prepare your car and yourself for beginning HPDE (high performance driver's education) so that you are ready to have a fun time once you arrive to drive on the

racetrack. Safety and knowledge are always the first consideration for fun and success on the racetrack, whether participating in a HPDE or a race.

questions, can help you with what you're working to improve. You can also hire them as coaches to really make a difference in your driving on the track.



Ron Zitza welcomes attendees



Reviewing race data

Eric gave a demonstration of how to use Data Acquisition Systems to improve your times on the track and showed how to analyze your driving for optimum development with maximum fun. Split seconds and planning ahead can mean the difference between winning and losing in racing as well. Both Ron and Eric are seasoned racecar drivers and just a few minutes asking them a few



Race car row

Besides all the Zotz Racing expertise, there were dozens of beautiful Porsches for viewing that they store and maintain for HPDE and racing. They also perform repairs for your daily Porsche.



PROVEN EXPERIENCE. PORSCHE EXPERTS AND CHAMPIONS FOUND HERE. FAMILY OWNED AND OPERATED SINCE 1960.

- Routine maintenance on track and street vehicles
- Trackside service
- Engine building
- Transmission repair
- Fabrication
- Private driver instruction
- Arrive and drive
- Pre purchase inspection

ZOTZ RACING & ZOTZ AUTOWERKS

6625 Edgewater Dr.
Orlando, FL 32810

Phone: 407-294-0024
E-mail: zotzracing@gmail.com

www.zotzracing.com

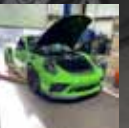

Facebook.com/zotzracinginc



@zotzracing

"This is the day the Lord has made; let us rejoice and be glad in it"
Psalm 118:24

Kaffeeklatsch Report

Photos by David Kelly and Sue Kee

Space Coast members brought their cars out for the Vero Beach Kaffeeklatsch, Melbourne Kaffeeklatsch and Daytona Kaffeeklasch for our monthly get togethers. There continues to be a great variety of Porsches to enjoy, including a meticulously restored 356 Coupe, 911's, GT4's, Boxsters along with beautiful Caymans. As always there's plenty to see with lots of details and unique features on each car on display at all locations which grabs significant interest from passers by who stop to check out the cars.

Come on out and check it out for yourselves and make some great friends.



The Larry Wilson Car Collection and Brian Redman's Targa Sixty-Six

Article and photos by David Kelly

On Saturday, February 12, 2022, members of the Space Coast Region gathered for a sporting back country drive to see the Larry Wilson Car Collection in Jupiter, FL. which was arranged by our good friend and professional automobile detailer, Alfred Marino.



The cars were spectacular in every sense of the word, as was the venue. The Wilson Collection staff afforded us a great welcome and were very accommodating, answering numerous questions and explaining the history and nuances of each car in the collection.

After reluctantly leaving such beautiful cars, we continued on to the Palm Beach International Raceway to see the action at Brian Redman's Targa Sixty-Six event which features exotic race cars of every marque on the track as they were originally intended to be driven. Once again, it was a great opportunity to see some unique and rare cars in the Paddock and in action on the track. Former professional racing drivers Brian Redman, Derek Bell, and David Hobbs, were on hand and happily answered questions about their illustrious racing careers and posed for photos with many of the visitors at the event.



Awesome Porsches in the Collection

No matter what automobile marque you favored, you would likely find it at Brian's event. There were Porsches, Ferrari's, and BMW's aplenty in the Paddock, along with several prototypes and other historically significant race cars. Some great examples were the Revs Institute Collier Collection which was there with two Porsche 904 GT's, chassis #904-018 the 1964 Sebring 12 Hour Class winner driven by Briggs Cunningham, and chassis #904-046 which raced in

the Targa Florio and at Nurburgring, and a Porsche 910/6 #910-007 which raced at Nurburgring. The silver 904 Cunningham car, with its #37, is all original and as it was when it won at Sebring in 1964. It was back in action again on the track at Targa Sixty-Six, courtesy of Revs Institute! There were more examples of racing heritage around the Paddock as you will see in the photos. The links to both venues which can be seen on our website spc.pca.org.



Great turn out of Space Coasters



Is red paint really faster?



Quality cars everywhere you look



Just for Fun! New Member Social

Article by Steve and Alice Tarr

Photos by Tony Whalen and Robin Hoffman

It was a cool and overcast Saturday morning when we turned the key on our 2008 C 4 CAB to start our day helping coordinate the New Member Porsche breakfast which began at 9:00 am at Porsche Melbourne. Upon arriving, you could smell the fresh coffee and sumptuous breakfast fare. Donna Edwards and her team had already arranged and placed numerous choices of breakfast sandwiches, juice, fresh fruit, and bagel out for all to enjoy. All courtesy of Porsche Melbourne.



Breakfast with cool cars...

Robin Hoffman, our past President, was busy greeting people with her warm smile. She had put together a detailed check-in sheet asking what year you joined PCA and how many events you had attended? The great thing about the day was the variety of members we had attend. Jeff Clift has been a member since 1989, attending while Mark



...thank you
Porsche Melbourne

Regan, Kenneth Meertens along with Rick and Debbie Hudgins all had joined in the first 3 weeks of 2022! Robert and Christine Geiger joined the day before the event and say they really enjoyed the day! Elissia and Paul Bennice were busy giving new members their name badges – they made over 30 new badges for the event! We started adding red dots to new members name tags to indicate their “newness”. People seemed to enjoy seeing red dots of each other’s badges and knowing they weren’t the only newbies!

Close to 80 members attended the new member social. 30 were NEW MEMBERS either in 2021 or 2022. A total of 14 were attending their first PCA meeting. WOW – the day began even better than planned and it was just 10 am.

Club door prizes were given out during breakfast including Space Coast Porsche Club bags, our 2022 Porsche Space Coast Charity Calendar, and golf towels. Robin went over the list of upcoming events and Sue Kee, Editor of our Space Coast Porsche Club magazine **Escape Velocity**, encouraged new members to share with her their pictures and adventures of Porsche ownership for all to enjoy.

After breakfast, it was great to see the long line of different Porsche models wearing Mexico Blue, Alpine White, Guards Red, GT Silver, Black, Signal Orange along with so many other colors as they turned right out of the dealership and headed South on Highway 1 – next stop – Vero beach. Everyone was on their own for the drive. Some took the scenic route along A1A and stopped at the Sebastian Inlet State Park. Some took the faster route along Highway 1 stopping to see Mel Fisher’s Treasures Museum with gold coins from the 1715 Spanish Fleet shipwreck. Others did some shopping beachside or at

Discount Coupon

PCA Member Price 15% Discount

On ALL Minor Services! On ALL Major Services!

This offer expires July 31, 2022. This offer not valid on previous service and cannot be combined with any other offer. See service advisor for details.

Porsche Melbourne

—2019—

**PREMIER
Porsche Dealer**



PORSCHE

Chris Huck

Porsche Sales Since 1997

Porsche Melbourne

509 East NASA Blvd. • Melbourne, Florida 32901

Phone: 321-956-0600 • Fax: 321-956-1400 • Cell: 619-339-3537

Email: cahuck@porscheofmelbourne.com

Website: porscheofmelbourne.com

—2019—

**PREMIER
Porsche Dealer**



PORSCHE

Dylan Kotoulis

Certified Brand Ambassador –
Sales Professional

Porsche Melbourne

509 East NASA Blvd. • Melbourne, Florida 32901

Phone: 321-956-0600 • Fax: 321-956-1400 • Cell: 407-334-7967

Email: dkotoulis@porscheofmelbourne.com

Website: porscheofmelbourne.com

the shopping mall. The plan was to connect with other PCA members and then meet at 1 pm at the Great American Brewery in downtown Vero Beach to have lunch together.



New members ...



... making new friends



Outside the brewery

The Great American Brewery is a historical site which dates back to 1926 and was the home of the City of Vero Beach Municipal power plant until late 1950. In 2016, with a \$6 million renovation, the building and property were reutilized as a best in class brewpub and production brewery! They have an upstairs seating area that was perfect for us. Special Space Coast Region PCA cooler bags with treats were handed out to each car owner. A total of 20 of them even had a gift card hidden in it for use at the brewery. A grand prize was graciously donated by the brewery along with several of the gift cards. Nothing beats spending time together over a meal to begin new friendships and talk Porsche cars. We also appreciated longtime PCA members Stan and Loretta Bowers being on hand to help greet members and help them feel at home. One PCA member from the Vero Beach area invited those at his table to stop over and see his other Porsche cars!

Come out and join us for an upcoming Space Coast Region PCA event to meet new friends, build upon old acquaintances and participate – just for fun!



Pretty Porsches all in a row



Inside the brewery enjoying a cold beverage

AN INVITATION TO STOP AND STARE

REAL ESTATE SERVICES WITH STYLE + PERFORMANCE

Owners + Husband & Wife Team + SPC.PCA Members: Robert Geiger, Pharm D., Broker + Christina Geiger, BA, CLHMS, Realtor®
 PCA Members Receive Special Incentives. Contact Us To Find Out More. 321.831.9193. GeigerTeam.com

PHOTO: BY CHRISTINA GEIGER, 2006 PORSCHE CARRERA S, MELBOURNE, FL



The Roar Before the 24

Article and photos by Jeff Dorman

Known as the “Roar Before the 24,” cars are qualifying to compete in the Rolex 24, a punishing 24-hour race at the speedway, where some of the world’s top drivers take to the track.

The Roar Before runs the weekend prior to the Rolex 24 At DAYTONA, is presented by INX and sets up two back-to-back weekends of intense IMSA action! In addition, Scout Days returns to the infield where thousands of scouts from across the nation convene for two nights of camping in Daytona International Speedway’s iconic infield!



Boy Scouts in the infield

Space Coast webmaster Jeff Dorman attended the Roar on Friday, January 23rd. “It looked to be rain-free for the season-opening of this IMSA 2022 season and I arrived around 9 am to watch the Prototype Challenge cars first on track, then I headed off to the paddock to take in the WeatherTech and Michelin Challenge entrants. These cars were in various states of preparation for their opening sessions, coming up shortly. I got to the International Horseshoe (Turn 3), as the Michelin Challenge cars and WeatherTech series cars took to the track. Then over to the Turn 1 high bank to capture the WeatherTech entrants, then off to the straight between the West Horseshoe (Turn 5) and the entry to the high banks to capture a variety of comings and goings. There was a lot to take in.”

The Roar Before is lots of fun, and so easy to check out the garages and see the drivers up close and personal. It’s well worth the trip to Daytona for this great event.



The battle in Turn 3



No lack of action in the pits



Many manufacturers compete



Checking the Porsche’s brakes



Many wheels in motion up and down the paddock

2022 IMSA Pilot Challenge

Article and photos by John Oreovicz

Porsche achieved a dream North American debut for the new 718 GT4 RS Clubsport with a 1-2 finish Friday in the Grand Sport (GS) class of the BMW M Endurance Challenge, the opening round of the 2022 IMSA Michelin Pilot Challenge season.

Stevan McAleer, in the No. 28 RS1 Porsche, stalked Owen Trinkler's identical No. 64 Team TGM Porsche for several laps as the final 30 minutes of the four-hour race unfolded, finally edging past in the famous tri-oval section of Daytona International Speedway with just under 13 minutes remaining. From there, McAleer eased the Porsche he shared with Cocoa, Florida, native Eric Filgueiras to a 4.631-second margin of victory over the No. 64 car co-driven by Ted Giovanis.

It was the 10th Michelin Pilot Challenge victory for McAleer, a 37-year-old Scotsman, and the first for Filgueiras in his first IMSA race of any kind. It was also Porsche's first win in any form of IMSA competition at Daytona since 2018, also delivered by RS1 in the Michelin Pilot Challenge.

"I grew up about an hour south from here, came to this race all my life, and always said I was going to be in it one day," Filgueiras exclaimed. "This is my first IMSA race and my first IMSA win, and I'm just so glad to be here. I don't know how to describe what this means to me.

"Stevan McAleer is an absolute hero, and that's why we hired him," Filgueiras added. "He took his time, he was persistent and he was patient. You could see that (executing the winning pass) took time. He kept asking how much time was left, and you could see he made a couple attempts that didn't quite work as he tried to feel things out. This was an absolute team effort."



McAleer said he encountered a gearbox glitch about 30 minutes into his stint that required him to recycle the Porsche's electronics. After that, the car was flawless and fast – albeit, no longer in the lead. "It was frustrating watching cars passing me left, right and center," McAleer said of the moments when he slowed and had to reboot the car. "We had a little bit of work to do, but the car was utterly fantastic. It shows how good the new Cayman GT4 platform is because so many teams have moved forward with this car."

The final restart came with McAleer running sixth, but he was confident in working his way to the front. He harbored a bit of worry about Trinkler in the leading Porsche. "I wanted to play the game smart and certainly not take two Porsches out at the end of the race," McAleer said. "Credit to him because we touched fenders a few times."



Rallye Daytona

Article and photos by Robin Hoffman

On Friday Jan 28th under cloudy skies, a group of us set out on a beautiful drive to kick off the Rolex Race! We met at Daytona One and drove past the Speedway on our way. Friday already had quite a crowd gathered for the Rolex and the Speedway was a flurry of activity and excitement.



Ready to Rallye



On the Ormond Loop

Our route took us up through Ormond, the Ormond Loop, up to A1A to Flagler, then west to the "Old Brick Road," to the Ponce de Leon Inlet Lighthouse. We had a few sprinkles but a wonderful drive complete with planned stops to keep everyone together and bladders empty! Thanks to Steve Martin for setting this up for our club and designing the cool logo – hopefully this will become an annual event!



Good group of drivers

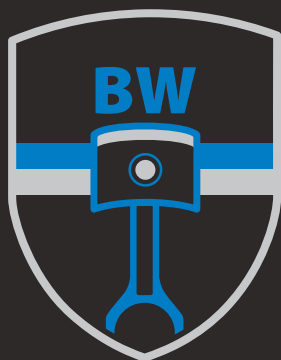

BREITWERKS

ENGINE SPECIALISTS

- ▶ Air & Water Cooled
- ▶ Complete Engine Rebuilds
- ▶ Performance Enhancements
- ▶ Reliability Improvements
- ▶ Realistic Budget and Time Estimates

321-806-8664

www.BreitWerks.com

email: info@breitwerks.com

2735 Center Place, Suite 7
Suntree, Florida 32940

Keeping the Tradition

Article and photos by Ed Springer

Every year since 1998, except for 2010, I've been fortunate enough to attend the premier endurance motorsport race in North America, the Rolex 24 Hours of Daytona. It's an amazing event that allows spectators up-close encounters with the race cars, drivers, and teams. Once the race starts, there are many great viewing areas around the track to safely watch the action. The atmosphere of the infield is like a carnival with displays, vendors, performances, food trucks, fireworks, and other fun and games. One of my favorite infield features is the PCA corral, where those who purchase the PCA package can park in a designated area with other street going Porsches. PCA hosts a hospitality tent located in the corral where they offer beverages, snacks, tables and seats, race video feeds, and tchotchkes. The tent also serves as a gathering point for Porsche fanatics to socialize or for folks to seek shelter from weather.



Porsche hospitality tent

This year's event, the 60th running, was one of the coldest weekends in the history of the Rolex 24. The high on Saturday was in the upper 40s Fahrenheit, overnight temperatures dipped into the low 30s, and the daytime high on Sunday barely stepped into the 50s. Yeah, I know... just about anywhere else in the country would have welcomed these "winter" temperatures, but this was a bit nippy by Florida standards. The cool temperatures impacted both the race and spectator scene. On the track, the turbo cars were whistling away with fast laps, but everyone was equally disadvantaged after tire changes. Since tire heaters are not allowed, leaving the pits on cold/slippy tires was dicey as drivers worked to put power down and build up tire temperatures while contending with cars at full race pace. In and around the track was jam-packed with spectators before and during the initial hours of the race. As the race went into the



Payse makes his mark

evening hours, the stands and parking lots thinned out except for the die-hard race fans and what I suspect were visitors from the north already acclimated to the cold.

For those who persevered at the track or watched the end comfortably in front of a screen, the race finale did not disappoint. Helio Castroneves piloted the No. 60 Meyer-Shank Racing Acura DPi to the overall victory after holding off the hard-charging No. 10 Konica Minolta/Wayne Taylor Racing Acura DPi driven by Ricky Taylor. But the real barnburner was in the GTD Pro class where Mathieu Jaminet in the No. 9 Pfaff Motorsports Porsche GT3 R went wheel to wheel with Laurens Vanthoor in the No. 2 KCMG Porsche GT3 R. In the contentious battle Vanthoor and Jaminet traded the lead twice in the last 5 minutes of the race. Their final contact happened in the chicane/bus stop and sent up a large plume of dirt just in front of overall winner, Castroneves. Jaminet was able to recover and get going slightly quicker than Vanthoor and crossed the finish line 1st in the GTD Pro class. Unfortunately for Vanthoor, during the final scuffle Alessandro Pier Guidi in the No. 62 Risi Competizione Ferrari snuck by to claim 2nd in class. Vanthoor managed to finish on the podium 3rd in class. Porsche also did well in the GTD class with Jan Heylen piloting the Wright Motorsports Porsche 911 GT3 R across the finish line for a 1st place finish in class.

The 60th running of the Rolex 24 hour race continued both a personal tradition of attending the annual event and Porsche's tradition of winning endurance motorsport events. Next year the tradition(s) will continue, and rumor has it Porsche is joining forces with Team Penske to campaign a LMDh (Le Mans Daytona hybrid) prototype.

Peter R Tyson Inc.

Marine and Aviation Insurance

"Excellence since 1977"



P.O. Box 644378 • Vero Beach, FL 32964
641 17th Street • Vero Beach, FL 32960

Tel: 772-770-0414 • Toll Free: 866-305-0334
Fax: 772-770-0343 • Cell: 305-588-0466

Email: Tyson@PeterRTyson.com

The fruits of our labor just got even more enjoyable.

Introducing a car that delivers more of everything you want in a Porsche. The new 911 Carrera GTS. With a twin-turbo flat-six that delivers 473 hp 0 to 60 in 3.2 seconds. An updated SportDesign exterior with Satin Black finishes. Making it the perfect car for those who can't get enough of too much.

Experience the 911 Carrera GTS.



Porsche Melbourne
509 East NASA Blvd.
Melbourne, Florida 32901
Tel. 321-216-2930
porschemelbourne.com

© 2022 Porsche Cars North America, Inc. Porsche recommends seat belt usage and observance of traffic laws at all times. European model shown. Some options may not be available in the U.S.



PORSCHE

The dessert before dinner.

Power. Speed. Pinpoint Porsche handling. One serving of the Macan S is all you'll need. But surely, you'll want more. Porsche. There is no substitute.

**The Macan.
Choose Thrilling.**



Porsche Melbourne
509 East NASA Blvd.
Melbourne, Florida 32901
Tel. 321-216-2930
porschemelbourne.com

© 2022 Porsche Cars North America, Inc. Porsche recommends seat belt usage and observance of traffic laws at all times. European model shown. Some options may not be available in the U.S.



PORSCHE

Member Spotlight

Ed Springer

Interview and photos by Ray Baldino

Ray: Our special guest today is Ed Springer. I think a lot of you folks out there have heard of him. So, tell me Ed what car do you have here today?

Ed: Thanks, it's a 1973 Porsche 914 2 Liter. This was an effort originally by Volkswagen and Porsche. As Volkswagen was phasing out the Karmann Ghia and Porsche was going to phase out the 912. It was a collaborative effort but Porsche ended up really taking the ball and running with it and putting out this cars. First, mid-engine streetcar manufactured by Porsche.

Ray: You just don't see these cars on the road much anymore. I see one maybe once every year on the road. How is the ride?

Ed: I find it very enjoyable. These are the cars that I grew up with, did PCA events and autocross events with my father. It's pretty nostalgic for me to get behind the wheel and still drive them and feel and drive the same way that they did back in the 80s and 90s.

Ray: So I see, it's a manual. Tell me about how its equipped.

Ed: It's a five speed but because the engine and transmission are behind you it has a dogleg transmission meaning that first gear is where most second gears are and then reverse is up and to the left.

Ray: How long have you owned this car?

Ed: I've had this one for two years. I started getting the bug to kind of relive some of the experiences I've had in the past with Porsche and wanted to add one of these to my collection. So I looked around for about six months and found this one, it was in Denver and had been brought back to life after 19 years in someone's garage. An interesting history on this car. So the original owner worked on the Titan rocket program and he lived in California. Then the individual I bought it from worked on the Atlas and Delta program. I also work in the space industry as well. So all ownership has been with folks in the space industry.

Ray: It has a very "space looking" design, very futuristic. I mean, this is just a fantastic car. Has it been restored?

Ed: Never been restored. It's very original. In fact, even the 914 cars I drove in the 80s had a lot of things already replaced. As I walk around this car and work on this car I recognize the originality. It also has most of the original paint, and the original fuel injection, which was the D-Jet. Most people had problems, keeping them in tune or not running optimally. So they replaced it with carburetors, but this still does have the original fuel injection.

Ray: So tell me a little bit about your stable, what other Porsches do you own?

Ed: I have three 911s and three 914's. So this is the only Street going 914, the other two are project race cars. They're really dedicated race cars with roll cages, and all the safety equipment, such as fuel cells, bigger brakes. Those are heavily modified whereas this one is just a pure original driver. The 911s consist of my father's Targa that he had since 1978. Currently working on a 1973 911 RS Tribute car it's going to be pretty hot rodded out with a 3.6 Twin plug 911 engine. The last one I'm working on is a 1973 911e Targa.



Ray: You got your hands full, with these Porsches.

Ed: It's a sickness.

Ray: I understand. There's a lot of people with the same disease. Well, we photographed your family today. Tell me a little about them.

Ed: My beautiful wife Kara, we've been married coming up on 13 years, and in fact Ray you were our wedding photographer, so you remember the day as well as we do. Now we have two kids, five-year-old Slayton and seven-year-old Payse. We're growing a family and getting them out to events and seeing if they're going to pick up on the car bug.

Ray: Well, you've got a beautiful family and also a beautiful family of cars too. I thank you again for your time today, and we look forward to seeing maybe some pictures of your other cars.



**dents
dings
creases
hail damage**

Hans Carrion

**paint-less
MINOR reconstructive surgery**



for your VEHICLE

t321 508 4489

February Autocross

Article by Carmen DeVito

Photos by Rick Rootsey, Robin Hoffman and Cindy Hambidge

The Space Coast Autocross Team kicked off the Porsche Melbourne Sponsored 2022 series on February 12 with 34 Porsche drivers competing under perfect conditions at American Muscle Car Museum.

This is the first autocross using the new 2022 PCA autocross classes. There are fewer classes, resulting in new groupings of more drivers competing together. Should make for an interesting year! Tim Marshall took Fastest Time of Day with a 51.774 and first place in class P04 with his 2009 Cayman S. Only .02 seconds behind and first in class P05 was Jimmy Strater in his 2014 Cayman S. Rick Baz and George Krivo were next fastest and the sole drivers M04 and P06 respectively. The difference among these drivers was less than 0.9 sec. Cindy Hambidge driving a Boxster S won the Ladies class with a 55.885 over Alexis Colgan and Julie Wilson. Forbes Anderson scored a 62.965 in a 1987 911 edged out Roger Duff in class S02 by only 0.4 sec. In class S03 Richard Fickes took first by .03 sec in his Cayman over Kirk Johnson.

The closest result was visiting husband and wife autocross cochair from SunCoast region Kirsten and Jerry Eggert, driving the same 2003 Boxster S in P03. Jerry took the lead on his last run with a 52.892 sec which was good for first over Kirsten's 53.087, giving them class first and second places in class and 5 and 6 over all respectively. Close behind the Eggert's in P03 were Tom Prusaski and Bert Castrejon both in Caymans. Brian Kraemer showed us how to hustle a big four door V8 taking the Panamera to a first in class S09 and 7th overall with a 53.561sec run! Greg Clifford drove his 1977 911 to a very quick 57.219.

Everyone had a good time and we are looking forward to doing it all again next month!



Go Cindy go!



Great time



Having fun

34 Porsche drivers, let's go!



Line 'em up

Space Coast PCA - Autocross #1 - February 2022 - Sat 02-12-2022

Final Results
Total Registered: 34, with Times: 34

LADIES - LADIES'		Car Color	Run 1	Run 2	Run 3	Run 4	Run 5	Total	Diff.	
Total Entries: 3										
1T	LADIES	118 Cynthia Hambridge	Boxster S	Aqua Blue	67.320+1	56.347	55.885	55.720+2	56.337+1	55.885 [-11.029]
2	LADIES	115 Alexis Colgan	991.2 GTS	White	63.46	59.616	57.133	56.914	56.901+2	56.914 [1.029]
3	LADIES	95 Julie Wilson	2015 Cayman GTS	Black	68.149	66.506	65.304	66.205	64.539	64.539 [7.625]
S02 - S02'										
Total Entries: 3										
1T	S02	146 Forbes Anderson	1987 911 Cab	Black	68.199	DNF	69.909	65.609	62.965	62.965 [-10.495]
2	S02	104 Roger Duff	2002 Booster S	Silver	DNF	65.002	63.61	63.46	68.905+DN	63.46 [0.495]
3	S02	156 Jack Gudim	2006 Booster	Yellow	DNF	100.592	90.112	77.108+1		79.108 [15.648]
S03 - S03'										
Total Entries: 3										
1T	S03	28 Richard Fickes	2007 Cayman S	Black	57.451+1	56.684	55.933	55.306	55.175+1	55.306 [-10.381]
2	S03	138 Kirk Johnson	2009 997 911	White	61.12	59.945	57.607	57.236	55.687	55.687 [0.381]
3	S03	987 Ken Krosolowitz	2006 Cayman S	Silver	65.674	61.466	61.466	59.564	61.932+3	59.564 [3.877]
S04 - S04'										
Total Entries: 1										
1T	S04	106 Doug Droppo	2004 911 Cab	White	62.966	62.077	63.402	60.673		60.673 [-]
S05 - S05'										
Total Entries: 1										
1T	S05	88 Jay Hall	2017 Cayman	Graphite Blue	68.551	63.439	62.646	60.076+1	59.528+2	62.076 [-]
S06 - S06'										
Total Entries: 2										
1T	S06	134 Jeff Nester	2021 Cayman GTS	White	68.806	62.222	59.599	59.236	58.734	58.734 [-12.158]
2	S06	153 Ed Monoski	2012 Carrera S	Blaak	88.884	80.159	74.033	DNF	70.892	70.892 [12.158]
S07 - S07'										
Total Entries: 1										
1T	S07	111 Marv DeBeque	2004 GT3	Red	DNF	63.637	61.989	61.423	60.424	60.424 [-]
S08 - S08'										
Total Entries: 1										
1T	S08	140 Chuck Yates	2020 GT4	Miami Blue	63.496+1	61.922+1	60.158+1	58.925+1	56.452+3	60.925 [-]
S09 - S09'										
Total Entries: 3										
1T	S09	109 Brian Kraemer	2018 Panamera	Grey	54.509	54.545	54.149	53.561	53.704	53.561 [-14.480]
2	S09	14 Bruce Kraemer	2018 Panamera	Grey	60.272+3	58.282	57.401+1	56.041+1	58.091	58.041 [4.48]
3	S09	148 Brennan Tope	Macan GTS	Red	76.002	71.461	66.159	65.650+1	66.769	66.159 [6.595]
P02 - P02'										
Total Entries: 1										
1T	P02	771 Greg Clifford	1977 911s	Silver	58.958	58.484	57.234	57.219	57.403	57.219 [-]
P03 - P03'										
Total Entries: 5										
1T	P03	141 Jerry Eggert	2003 Boxster S	Grey	56.102+1	72.838+DNF	55.897	52.892	DNF	52.892 [-10.195]
2T	P03	144 Kirsten Eggert	2003 Boxster S	Grey	55.608	54.845	53.539	55.488	53.087	53.087 [0.995]
3	P03	5 Tom Prusaski	2006 Cayman S	red	DNF	55.221+1	53.829+1	55.213+1	53.738	53.738 [0.651]
4	P03	149 Bert Castrejon	2006 Cayman	Black	58.666	55.103	54.853+1	55.136	55.252	55.103 [1.365]
5	P03	145 Sean Beery	2000 Booster S	Blue	78.446+1	68.387	62.526+1	63.97	63.426+2	63.97 [8.867]
P04 - P04'										
Total Entries: 4										
1T	P04	22 Tim Marshall	2009 Cayman S	Silver	53.634	53.218	52.109	52.398	51.774	51.774 [-19.573]
2T	P04	119 Robert Skelton	2002 996 911 Targa	Silver	65.308	62.222	61.347	61.77	61.347	61.347 [9.573]
3	P04	42 Ken Grudens	2007 997	White	DNF	70.841	66.314+1	65.098	63.924	63.924 [2.577]
4	P04	155 Henri Broussalan	2003 911	Red	71.031	71.033	66.598	65.990+1		66.598 [2.674]
P05 - P05'										
Total Entries: 4										
1T	P05	33 Jimmy Strater	2014 Cayman S	Black	53.166	52.064+1	52.788+1	51.95	51.768+1	51.95 [-12.719]
2T	P05	113 Andy Colgan	2019 991.2 GTS	White	57.782+2	57.501	54.952	56.467	54.669	54.669 [2.719]
3	P05	6 Glenn Matchett	2012 911 Carrera S	Noisy White	60.251	57.346	56.582	56.477	55.24	55.24 [0.571]
4	P05	75 Stephen Wojcicki	2014 Cayman S	Cognac Metallic	58.131	57.156	56.803+2	55.397	55.515	55.397 [0.157]
P06 - P06'										
Total Entries: 1										
1T	P06	127 George Krivo	2021 GT4	Blue	53.145	53.396	52.776	52.557+1	52.636	52.636 [-]
M04 - M04'										
Total Entries: 1										
1T	M04	61 Rick Baz	996 Turbo	Basalt Black	53.91	52.127	52.214	52.708	52.008	52.008 [-]

Note: These are new 2022 Parade classes



A tough course



Burning daylight, let's get started

THEY SPEAK FOR THEMSELVES

STATEMENT!

Get In Touch

Statement! Marine LLC
6101 45th Street North, Unit 4
St. Petersburg, FL 33714

Sales: 954-614-2591
Email: cnbarrie@gmail.com
Factory Main: 727-525-5236

SERVING BREVARD COUNTY SINCE 1947



Glover Oil Company has been committed to meeting Brevard and surrounding county's petroleum needs for over 65 years.

93 OCTANE NON-ETHANOL GASOLINE

- Boats, small engine equipment and performance cars
- Convenient Drive-Thru Service

AV GAS

- Low Lead 100 Gasoline
- Airboats and Aircrafts
- Convenient Drive-Thru Service

321-723-3953
3109 South Main Street
Melbourne, Florida 32901
www.gloveroil.com

Glover Oil
Company Inc.

Space Coast Classifieds

FOR SALE: 1983 928S



Multiple Concours winner with the same owner for 23 years. Runs very strong, excellent condition. Slateblue Metallic, black interior with very rare cloth Porsche script insert seats. Many upgrades and spare parts. 4 Speed Auto. Asking price \$29,000.

Please call Jurgen at (772) 643-5162 to schedule appointment !!!

FOR SALE: 2005 911 Carrera S



Garage kept, excellent condition. Tiptronic S, sunroof, Bose speakers, power windows/locks/mirrors. Both power and memory seats. 60,000 miles. New paint protection film. New Pirelli P Zeros. Arctic Silver over Cocoa Brown. \$46,000. Call or text Perry West at (321) 427-2510 or email at pdwest@att.net.

Got a car to sell?
Like to advertise
it for **FREE?**
Yes, FREE!

Send an email to
suekee.ev@gmail.com
to place your ad in
Escape *Velocity*.

PLATINUMWERKS Collision Center of Melbourne

The ONLY Porsche factory approved body shop in Brevard County.

PORSCHE

**APPROVED
COLLISION CENTER**



Danny Baker
Executive Director

Confessions of a Porsche Wife: Ready or Not, Here Comes Parade

Article and photos by Trina Gorsuch

Most women I know plan their summer vacations to tropical locations with a focus on relaxation and pina colodas. Only a Porsche Wife would trade it all in for her husband to decide “Babe, instead of a cruise to the Bahamas, let’s go to Parade for an entire week!” This vacation will instead have a focus on revving engines and performance cars. I mean, that’s what every woman wants, right?

It doesn’t seem like that long ago we were at Porsche Parade 2019 in Boca Raton. Although I do have tons of fun memories from that week, I also have tried to block out some of the more “memorable moments” that caused me slight anxiety. Now remember, I was pregnant at the time and had a nine-month-old baby, staying in a hotel for the very first time. It was rough. During the day we were out having adventures, missing naptimes, staying up late for the banquets and after parties, then while most club members went to bed, we would take shifts rocking our little one back to sleep. There was also that one excursion that didn’t really go as planned, and we ended up in a mud pit. But let’s not talk about that.

I don’t know whose great idea this was first, but all of a sudden going to Porsche Parade 2022 turned into a full-blown Gorsuch Family Reunion. It started out as Ryan suggesting “wouldn’t it be fun to go to parade? It’ll be Cody’s first time and my dad’s last year as National PCA President, so it could be our last chance to experience it that way as a family!” Not that I really had a choice. I understand this would be a once in a lifetime kind of deal. It’s a unique experience because Tom and Elaine Gorsuch get to host the events and throw a big party for a lot of important Porsche people. On the other hand, it’s going to be our first road trip and vacation as a family of four and I know will require a lot of patience for us to make it through it all – together.

Registering for Parade is a little like the start of a driving race. The online registration opens in the middle of the day and you literally wait for the moment the clock strikes noon and you hit refresh over and over as fast as you can until you get in to register. Ryan put the start time on our “family calendar”.

I was required to be there. We were working from home at the time, so he was yelling from across the house “it’s almost time, get ready!” As if that’s not enough pressure, my husband finds joy in being one of the lowest registration numbers. The first person to register is number 1 and we got number 191 and finished at 12:06 pm. Whew!

Travel next. Naturally Ryan wants to take the car. He says, “we can’t go to Parade without Holly; having her is half the fun!” I guess me and the kids are the other half? I can only hope. But, planning how to get me, my husband, my two kids, and our Porsche Cayenne to the Poconos is going to be no easy task. After much deliberation we settled on a solution- the Auto Train. We will drive to Sanford, board our car on the train and ride 900 miles overnight in the train cabin seats (where I guess we will sleep). Then we will arrive in Lorton, Virginia at 9 am, get our car and drive to Hershey PA. We will stay the night there, so we have time to visit Hershey’s Chocolate World Factory for a chocolate tour and gift shopping. I’m sure the kids will love it. The next day, day three of travel, we will then drive up the rest of the way to the Kalahari Poconos Resort where we will stay for the week of parade.

If this wasn’t enough coordination, throw in my sister-in-law with husband and 4 kids and Ryan’s cousin with wife and two



kids will all be joining us at Parade too! That’s 2 grandparents, 6 parents, and 8 kids ages - 11, 9, 9, 6, 3, 3, 3, and 2. Pause and let that sink in for a minute. Did I mention there’s an indoor water park across the street from the resort? Yup. I’m going to need a vacation after my vacation. So, if you see me at Parade surrounded by a mob of children, I’d appreciate if you’d just smile and maybe hand me the nearest pina colada. I’ll accept Starbucks lattes too. I’m not picky. #porschewifeprobs #PCAkids

Cebotech
WELDING SOLUTIONS
BY TECNA

From a Porsche certified shop to the enthusiastic restorer, we have the welder for you

US>Contact:
Cebotech Inc.
in Florida:
PH.(386)255-7090
www.cebotechusa.com
sales@cebotechusa.com

TECNA
www.tecna.net
sales@tecna.net
Made in ITALY

PORSCHE approved
TECNA 3664
Smart Plus

2022 Porsches and Polo at the Windsor Club, Vero Beach

Article and photos by David Kelly

Porsche people, Porsche cars, and famous Polo Players converged on Saturday, February 19, 2022 for an exciting event at the Windsor Charity Polo Cup, sponsored by Porsche Melbourne. All proceeds from the event went to support local charities. Convoys of Porsches driven by Space Coast members from the north and south met at the Windsor Club Polo grounds, field-side, to watch and enjoy the festivities and to participate in the “People’s Choice” Concours as part of the event. Porsche Melbourne staff made all the preparations and graciously hosted SPC members by serving a champagne lunch and providing shelter from the misty conditions that prevailed early in the day. Porsche Melbourne also brought along a selection of new cars to put on display for the Charity Cup attendees to inspect. Local merchants participated in the event by providing displays of their goods and products for Windsor residents, their guests, and our members to view and sample.

with the other players. The Windsor staff, residents, and guests were welcoming and gracious in allowing the Space Coast Region to participate in the event supporting local charities, and a special thanks go to Porsche Melbourne for its ongoing help, support, and sponsorship. You can see more pictures on our Space Coast website at spc.pca.org.



The People’s Choice Concours drew many Windsor residents and guests to the display to admire the cars and relate their own experiences with some of their favorite Porsche cars over the years. Winners of the Concours were a beautiful Blue 718 Cayman in 1st place, followed by a nice India Red 928 S4 in 2nd place, and an equally nice White 993 4S in 3rd place. You can see the three winners and their cars in the event photos. As the day progressed, the occasional sprinkles, windy and misty weather abated, and sunny skies prevailed late in the day.

The professional Polo players took the field in all conditions and the crowd was treated to some excellent polo playing highlighted by many well-known players, one of which, was Hope Arellano, a highly ranked Women’s and Mixed Polo player, known for her skill and ability to play in both tournament settings. You’ll see Hope in action, along



WE'RE ON YOUR SIDE

Your **INDEPENDENT**
ALTERNATIVE to Big Banks
& Brokerage Firms



Call today for your **FREE** consultation:
Robert DeVries • Trina Gorsuch • Tom Kirk • Ryan Gorsuch

(321) 773-7773
www.FirstWaveFinancial.com

Tech Spotlight

Ignition Coil Update/Ignition Coil Heat Shields/ 3.8 L Variocam Bolts Coming Loose

Article and photos by Rob Van Name

Porsche has come out with updated ignition coil packs applicable to many 9A1 flat six powered cars including the 981 Spyder and GT4. The new ignition coils may solve miss fires especially when tracking your car in high ambient temperatures and/or when using race exhaust headers. The new part number is 9A1-602-104-07. It is theorized that heat from the near by exhaust headers can damage the ignition coils especially cylinder #4 (driver's side forward in mid engine cars).

Impacted models:

- All Boxster & Cayman 2009-2016 (987.2 & 981)
- All Carrera/S/4/4S/Targa 2009-2012 (997.2)
- All Carrera/S/4/4S/Targa 2013-2016 (991)
- All Turbo or Turbo S 2010-2013 (997.2)
- All Turbo or Turbo S 2014-2019 (991)
- All GT2 RS 2018-2019 (991.2)
- All GT3/RS/RS 4.0 2010-2012 (997.2)
- All GT3, GT3 RS & 911R 2014-2016 (991)
- All GT3, GT3 RS & Speedster 2018-2019 (991.2)

Aside from the updated ignition coils you may want to consider adding some heat shields to reduce ignition coil temperatures in mid engine cars. I believe rear engine cars may already have these heat shields installed. These are available from Porsche, Fab Speed and BGB Motorsports, etc. FYI the BGB Motorsports parts are actually the Porsche parts. You will have to check which heat shield set up might apply to your car.

I believe these are applicable heat shields usable on 981:

Lower shield, Right P/N 9A1-104-314-00

Lower shield, Left P/N 9A1-104-313-00

Upper shield, Left P/N 9A1-104-311-00

Upper shield, Right P/N 9A1-104-312

Qty 8 Torx screws, P/N 900-385-041-01

When changing spark plugs or ignition coils the upper shield must be removed. Here is an exploded diagram showing the heat shields from the internet.

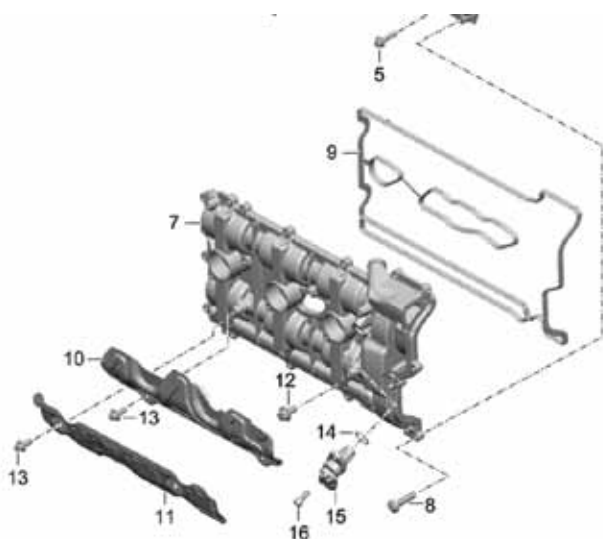

Here is a photo from a forum showing the driver's side upper heat shield. Installation is a pain, especially the lower ones. The bolts are torx head and at the rear lower heat shield bolt you might want to use a hex head bolt instead. Consider installing these heat shields when changing spark plugs.



Another exciting subject I learned of recently was the GT4 3.8 L Variocam bolts coming out on cars that have seen heavy track use or have regularly hit the rev limiter. From BGB Motorsports here are some scary photos when the bolts back out.



The solution to this issue is to replace the aluminum bolts with steel bolts that have been installed with thread locking compound. Porsche only sells the complete Variocam actuator, no separate bolts from what I understand. The bolt replacement can be done but the engine must be dropped so the replacement of the bolts is fairly labor intensive (~20 hours labor). Porsche has made good on some of these failures but a lot of debris wind up inside the engine. I asked at the dealer if there were any repair actions for this issue with my 981 Spyder and was told there were none. The bottom line I believe is if you are heavily tracking your 981 GT4 or 981 Spyder and the car has hit the rev limiter repeatedly you ought to get this fix done. I plan to have it done to my car by BGB to be on the safe side. At the same time the updated coil packs and heat shields can be installed more easily.

15th Annual Gathering of the Faithful

Article by Pete Bartelli

Photos by Robin Hoffman

The Gathering of the Faithful (GoF) is three-day event with the 356 Florida Owner's Group (FOG). Space Coasters who own 356's or are interested in 356's are welcome to join the FOG. This year's annual event included evening welcome parties, driving tours, concours tech session, People's Choice Concours, swap meet, a lavish banquet and door prizes! It was great fun with approximately 100 people in attendance!

The GoF registration table opened for business at 4pm Thursday. Within minutes, several dozen members had picked up their credentials and goodie bags. Next came out the hors d'oeuvres of shrimp, scallops with bacon, quesadillas, a cheese platter and more. The evening was absolutely perfect, the conversations engaging, and friendships renewed.

Friday was Tour Day. One tour went to Sugarloaf Mountain, a 312 foot "mountain" on the Lake Wales Ridge in Central Florida. It's the highest natural point in peninsular Florida. OK...so, it's not the Matterhorn, but it's OURS. The second 20+ car tour caravanned south towards the Green Swamp Wilderness Preserve....well, that was "The Plan" anyway. Eventually, most of the tour(ists) arrived at J.B. Boondocks for lunch....all except Mike and Debbie Owen with their recently acquired 1958 Aquamarine Blue Metallic Speedster. A distress call to Fernando Lopez, our favorite 356 mechanic, took him away from lunch and down the road some 18 miles away to help the stranded Mike and Debbie. An hour later, Nando got the car running by replacing a fuel pump spring with one from his ball point pen! What?! I've heard tales of fixes with bailing wire and chewing gum, but a ball point pen? Yes, the Speedster made it all the way home to Orlando too after winning top honors at Saturday's concours.



There are hills in Florida



Saturday was the much anticipated People's Choice Concours. Forty-nine beautiful 356s comprising 8 classes dotted the fairway. About 30 members of the Suncoast Region of the PCA on a Saturday driving tour visited us. Everyone enjoyed their company and mutual passion for all things Porsche. The day turned out to be pleasantly cool, clear and wonderfully serene.

Saturday evening was the banquet and awards presentation. Trophies were presented to the 25 winners. The winner by people's choice of the Rich Williams Memorial Best of Show trophy is the 1958 Speedster owned by Mike and Debbie Owen. Congratulations to all the winners. The \$1000+ worth of door prizes were all gleefully accepted and the evening concluded with a cheer.

The 2022 Gathering of the Faithful was a great event. The FOG... always keeping the faith.

356 UNLIMITED
Exclusive 356 Restoration Services

Rust Repair Paint & Body Routine Service
Award Winning Restorations

Still "Made by Hand"

356 UNLIMITED
2495 Jen Dr. Suite 14
Melbourne, FL 32940

356Unlimited@gmail.com 321-652-4654

A Florida Coast to Coast Porsche Adventure

Article by Tom Gorsuch

Reminiscent of our famous Sunrise to Sunset rallies, I recently completed a cross Florida tour with a group of Porsche enthusiasts. This time we traveled from Playalinda Beach in Titusville to Honeymoon Beach in Dunedin. We did it in four days, traveling about 60 miles a day and averaging 10 miles an hour. The pace was the result of the route through back country trails with numerous rest stops to recover from the constant peddling. That's right, we made the trip on Porsche bicycles.

Porsche has been making bicycles for the last 30 years. They are rare to see and even rarer to see them on the trail. To run across nine Porsche bikes of a wide variety is relatively unprecedented. But that's the kind of adventure this group of PCA members decided to take on. Last September we rode 360 miles from Washington DC to Pittsburg. Our northern contingent thought it would be nice if I could put together a spring training ride across Florida, to get them out of the cold.

Bob Rath, Chicago Region Past President, Bike RX; Cindy Jacisin, PCA Executive Vice President, Bike R; Terry Svoboda, Chicago Region member, Bike R; Jim Hemig, PCA Membership Marketing Director, Bike X; Gregory Brown, PCA Registered Agent in DC, Bike FS; Todd Benz, PCA Secretary, Bike FS; Vu Nguyen, PCA Executive Director, Bike R; Tom Gorsuch, PCA President, Bike RS; West Dillard, PCA Club Racing Chair, Bike RX. You can learn more about Porsche bikes in the March 2022 issue of Panorama.

Florida is working hard to develop a community sponsored network of cycling trails. Our trek followed the Florida Coast to Coast trail network. Day 1 was the East Coast Rail Trail to Sanford. This trail delivered on the Florida icons such as sandy dunes, palm trees, white pelicans, gopher turtles and alligators. All Space Coast cycling enthusiasts need to give this awesome, paved trail a ride. We were joined at dinner by our PCA Zone 12 Representative, Leslie Sikorski, at the Willow Tree German restaurant in Sanford—another must visit destination for local Porsche enthusiasts.

Day 2 took us thru several urban paved trails, below Lake Apopka and into Winter Garden. Old-Town Winter Garden has embraced the adventure travel trend, catering to cyclists with town center bike shops, cafes, and beer gardens. We sampled a little of each before heading on



Saddle up!



Hydration stop

to Lake Minneola. We stayed at the quaint and well-maintained Lake Minneola Inn where we were joined by Karyn Rinaldi, Citrus Region President, to enjoy a beautiful sunset and an excellent meal at their lakeside Tiki Bar.

Day 3 was the most challenging. The Florida Coast to Coast trail is not completed between Groveland and Brooksville. To avoid the busy SR50 bike lane, I routed the group thru the Richloam Wildlife Management Area. This was about 15 miles of hard pack dirt roads. There were several miles of freshly grated soft sand that caused our road bike participants to revert to bike hiking. Contrary to the weather forecast in the trip marketing brochure, this is where mother nature decided to deliver some heavy rain. The best we can say is the combination made for some muddy Porsche bike photo opportunities.

The final day traversed the Suncoast, Starkey Wilderness and Pinellas trails from Brooksville to Dunedin. If you ever find yourself on the west coast with your bike, take the time to visit the Starkey Wilderness trail. The Pinellas trail is famous for how it is integrated into the local communities with plenty of bistros and breweries to slow us down. We met up with the Gulf Coast on Honeymoon Island state park. The final two miles across the causeway delivered that last bit of Florida experience with a 20+ mph cross wind and driving rain that our northern friends will not soon forget.

We made one more Porsche cyclist must-stop at Kafe Racer. This high-end bike shop includes a full-service café and bar directly on

the Pinellas trail. It is owned by Jan Heylen, the highly successful Porsche GT racer and cycling enthusiasts. Jan met us at the shop to swap stories and to learn more about our Porsche hardware. Jan occasionally hosts Porsche events with the Suncoast Region along main street next to the shop. We celebrated that evening, watching the sunset from the rooftop bar at the Fenway Autograph Collection hotel in Dunedin.

A trip like this doesn't happen without the support of friends. The first challenge was getting nine bikes and nine riders to the starting point. For this we called on Steve Hoffman, Space Coast Region President, to get up early on a Monday morning and bring his car hauling trailer. I reminded Steve that the trailer needed to be pulled by a Porsche. I'm not sure he knew what he was getting into, but he's been around PCA long enough to not be phased by the challenge. Thank you Steve for providing the perfect launch transporter!



Elaine to the rescue

Our support and gear (SAG) minivan was driven by wife Elaine Christine. The van was packed every morning with our bike bags and luggage. Elaine took care of having our beverage cooler iced up every evening before we arrived at our destination hotel. On our day of dirt trails, Elaine met us at the historic, backwoods, Richloam general store buying ice cream for the crew who showed up looking lost, muddy, and tired. What a welcomed sight—an oasis in the desert.

Porsches and Pistols

Article and photos by Jay McGrath

On Saturday, February 26th a group of 23 Space Coast PCA members got together, although it wasn't a PCA sanctioned event, and had a night of target shooting at Frogbones Family Shooting Center in Melbourne. All members came that night in everything from Porsche 911's, to Caymans, to Spyders and more. It was a great time for comraderies and commonalities with a passion for Porsches and shooting.



Stephen Weston with Range Officer Bob

Frogbones Family Shooting Center provided a reserved hour of use of all of their pistol ranges, full use of all of their firearms, Range Safety Officers, targets, and even one-on-one



Chris Glass

training with a certified NRA Training Officer. This group who calls themselves "Pistol Packing Porsches" were said to have a great night out. Many of the group took Frogbones up on use of their normal rental firearms that they provided to us which were included in the one price per person. I saw many folks trying out new types of pistols, semi-automatics, and other types of firearms. The theme going into the night was safety, safety, safety as Frogbones Range Safety Officer got the group in a huddle and gave us a starting safety brief. Basically, everything was provided to us with the exception of ammunition. Many of our members brought their own firearms to hone their skills.

The takeaway from this is that Porsche people come from all walks of life and enjoy all forms



Cindy Hambidge

of recreation that we can all share. In this case we share the love of Porsches and also share the passion of shooting for fun. After our range time at Frogbones many of us stayed to have dinner and talk about the evening. We talked Porsches, life and Carmen Devito showed us all his new Porsche Turbo S that is coming soon. He provided us photos that Porsche sent him of the build, very cool.

I hope that this group "Pistol Packing Porsches" will continue to another activity similar to this one. We all had a great time and one that was safe too.

Like our motto, it is not just Porsches it's the People.

CRAFT BEER, WINES & COCKTAILS ON TAP

- EXOTIC BURGERS, Seafood & Top Quality Pub Grub
- WORLD CLASS BEER SELECTION
- 9 TVs w/ Sports
- Daily Food & Drink Specials

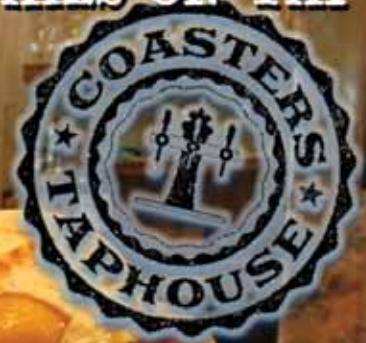

THE AUSSIE BURGER: Half pound burger with fried egg, bacon, cheddar, beetroot, lettuce, tomato & onion

COASTERS TAPHOUSE - 5675 North Atlantic Ave #122 - Cocoa Beach, FL 32931
(321)613-3041 -- Facebook.com/CoastersTaphouse

Werks Reunion at Amelia Island

Article by Robin Hoffman

Photos by Steve Hoffman and Damon Lowney

Werks Reunion is a PCA event to celebrate both the Porsche brand and enthusiast. It's not a typical concours where every speck of dirt and grease has to be removed from your Porsche but rather a judged show that rewards a Porsche that has been lovingly maintained and presents itself well on the field. Werks' judges do not use Porsche Parade Concours score sheets but rather rank the cars according to certain attributes such as length of ownership and the Porsche/Owner relationship story. 164 Porsches were on the "Judged" field and an additional almost 600 were displayed in the model specific Corrals. Werks is a casual gathering of Porsche enthusiasts focused on having fun rather than solely on competition.

It was so fun to walk around the beautiful golf course in Amelia Island and see friends from the Space Coast enjoying the day. Melissa Diaz's freshly wrapped 911 as LOL Surprise caught the eye of the PCA Junior Judging Team. Her granddaughter, Amelia, the one who inspired the wrap, was on hand to show off her pretty new car.

past few years, won second place in the 356 Class.



Lou Verdiales' Carrera RSR



Porsches everywhere

This year the 996-generation Porsche 911 was the highlighted model of the event. Space Coast member and National President Tom Gorsuch unveiled the PCA newly restored and modified 996 Classic Club Coupe as Werks' main attraction. The Classic Club Coupe, restored by Porsche Classic with help from Porsche Exclusive Manufaktur and input from PCA, PCNA, and Porsche AG, was truly a sight to behold!



Ready for offroad action



996 Classic Club Coupe reveal

Lou Verdiales brought his 1974 Porsche 911 Carrera RSR and took first place in the Competition.Race Class and our 1958 Speedster that has been in restoration for the

All PCA events require plenty of volunteers and Werks is no different. My husband volunteered to help set up the concours field on Thursday, then park cars and judge on Friday. I worked as a parking volunteer in the Corral on Friday. I loved welcoming people and directing them where to park. Volunteering is so much fun at PCA events. It gives you a sense of being "a part" of the event and the people you meet! I hope you will plan to come to the next Werks and pick up a volunteer shift – you won't be disappointed!



It's all about the people



There's not an app for this

INSURANCE DRIVERS CLUB CAR CULTURE MARKETPLACE

HAGERTY
Let's Drive Together

Local contact: Cason Vogel
904-252-3276 | cvogel@hagerty.com

Policies underwritten by Essentia Insurance Company. All third party makes, models, and vehicle names are property of their respective owners. Their use is meant to reflect the authenticity of the vehicle and do not imply sponsorship nor endorsement of Hagerty nor any of these products or services. Hagerty is a registered trademark of the Hagerty Group LLC. ©2020 The Hagerty Group, LLC. All Rights Reserved.

Space Coast Juniors at Werks

My First Porsche Adventure

By Aiden Greenwalt – Age 6

My Grandma and Grandpa took me out of school for my first Porsche event – Werks Reunion at Amelia Island on March 4, 2022. When we got to the PCA tent they gave me a model Cayenne Turbo, a Porsche T-shirt, and a hat. I went to a class where they taught us how to judge Porsches. We looked at the interior, exterior, engine, electrical and design and scored on a score sheet from 1 to 5 stars for each car. We judged a 356, 914, 911(Safari Rally), 928 and GT3. I voted for the winner – the Safari Rally 911. The driver told us they had driven 1900 miles off road to come to this event from Boston.



The best part of my day was being with my Grandma and Grandpa and seeing lots of cool Porsches. I hope I can do it again.

LOL Surprise Porsche

By Melissa (Mimi) Diaz

Amelia Rose (almost 5 years old) has been a PCA Junior with Space Coast PCA for about 2 years. She has been attending car events with her Mimi and Pop Pop since she was 6 months old. This was Amelia's first Werks Reunion and she was excited to share her love for Porsche and her LOL Surprise Porsche with those in attendance.



Amelia loved talking to those asking her about the car at Werks and would even pose for pictures for those who wanted them. She couldn't believe how many Porsches she saw and would point out some of her favorite colors. She even got to have her picture taken sitting on the the Famous Pink Pig.



Ready to Go!

By Robin (Mimi) Hoffman

Martin (3 years old) had been waiting all afternoon for his Papa to get home with his new Speedster. Papa gave him a wide berth when passing him in the driveway, but Martin was not deterred. He raced his bike as fast as he could to catch up and as a reward Papa gave him a ride in the Porsche before it got loaded in the trailer to go to Werks Reunion.



Space Coast PCA Jr Shirt

Austin Wynn (almost a year old) sports his Space Coast Jr Shirt after Grand Ron Menck made him an official PCA Jr Member. It's free to do as a family member of a child. Great to start them early! <https://www.pca.org/pca-juniors>



Working Together for Your Financial Future



Jorge Hoffmann
Financial Advisor

3819 Murrell Road Ste D
Rockledge, FL 32955
321-639-8510



Member SIPC
www.edwardjones.com

Edward Jones
MAKING SENSE OF INVESTING

coming attractions

- April 2** Kaffeeklatsch @ Wickham Panera, 9 am
April 10 Kaffeeklatsch @ Vero Panera, 9 am
April 16 PM Sponsored Autocross @ American Muscle Car Museum, 7:30 am
April 17 Kaffeeklatsch @ Jason's Corner, New Smyrna Beach, 9 am
April 23 Wheels & Keels @ Moorings Yacht Club, Vero Beach
April 30-May 1 Suncoast Region DE @ Sebring
April 30 New Member Breakfast @ Porsche Melbourne, 9 am

May 7 PM Sponsored Autocross @ American Muscle Car Museum, 7 am
May 7 Kaffeeklatsch @ Wickham Panera, 9 am
May 8 Kaffeeklatsch @ Vero Panera, 9 am
May 14 Tech Session @ Porsche Melbourne, 9 am
May 15 Kaffeeklatsch @ Jason's Corner, New Smyrna Beach, 9 am
May 27-29 Zone12 Zonefest 2022 Hosted by Space Coast Region and Sponsored by Porsche Melbourne and American Muscle Car Museum

June 4 Kaffeeklatsch @ Wickham Panera, 9 am
June 12 Kaffeeklatsch @ Vero Panera, 9 am
June 12-18 2022 PCA Porsche Parade, Pocono Mountains, PA
June 19 Kaffeeklatsch @ Jason's Corner, New Smyrna Beach, 9 am
June 25-26 Suncoast Region PCA DE @ Sebring

July 2 Kaffeeklatsch @ Wickham Panera, 9 am
July 11 Kaffeeklatsch @ Vero Panera, 9 am
July 18 Kaffeeklatsch @ Jason's Corner, New Smyrna Beach, 9 am

Save the Date:

- November 5** Space Coast Annual Oktoberfest, Concours & BBQ @ F. Burton Smith, 9 am

SPC events shown in blue. Dates and times subject to change. Keep an eye out for additional drives and other events that are still in the planning stages on our website calendar <https://spc.pca.org>.

A special thank you to our advertisers

356 Unlimited	page 29	G&T Realty	page 13
Baldino Photography	page 35	Hagerty Insurance	page 32
BreitWerks	page 16	Platinum Werks	page 24
Cebotech	page 25	Porsche Melbourne	pages 2, 12, 19, 20, 36, centerfold
Chris Huck/Porsche of Melbourne	page 12	SOS Dent	page 21
Coasters Pub	page 31	Statement Marine	page 23
Cobia Insurance	page 8	Tyson Marine and Aviation Insurance	page 17
Dylan Kotoulis/Porsche of Melbourne	page 12	Werkshop	page 7
Edward Jones/Jorge Hoffman	page 33	Zotz Racing	page 9
FirstWave Financial	page 27		
Glover Oil Co.	page 22		



Becke Hansen
2015 Porsche Targa

ray@baldinostudios.com
www.RayBaldino.com

321.446.4010



[baldinostudios](https://www.instagram.com/baldinostudios)



Ray Baldino
MASTER PHOTOGRAPHER

Automotive Art for the Distinguished Driver
Master Photographer Ray Baldino



SPACE COAST REGION

PORSCHE CLUB OF AMERICA

PO Box 372724 | Satellite Beach, FL 32937

PRSR STD
U S POSTAGE

PAID

COCOA FL 32926
PERMIT NO. 191

We have high standards. As do you.

You want something special. That's why you drive a Porsche and why you deserve equally special service. Precise, professional, dynamic, and above all: tailored to your exact requirements. Typically Porsche.

Service delivery and pickup now available.

15% Discount for all Parts & Service as a PCA Member.



Porsche Melbourne
321-216-2930 for your next appointment
porschemelbourne.com

©2022 Porsche Cars North America, Inc. Porsche recommends seat belt usage and observance of traffic laws at all times.



PORSCHE