

**NOBLES**



A TASMEA COMPANY

# General Purpose & Mooring Chain

CATALOGUE

# Table of Contents

---

GRADE L CHAIN.....	3
PROOF COIL CHAIN.....	5
COMMERCIAL CHAIN PACKS.....	7
COMMERCIAL CHAIN.....	9
SPLIT LINKS.....	11
TRAILER SAFETY CHAIN.....	13
MINING SUSPENSION CHAIN.....	17
STAINLESS CHAIN REG LINK.....	18
STAINLESS CHAIN SHORT LINK.....	19
STUD-LINK CHAIN & FITTINGS.....	21

## Grade L Chain

Grade L chain is the lowest quality tensile steel chain suitable for lifting purposes and is manufactured to AS 2321.

Grade L chain is widely used in the marine industry for anchor chain.

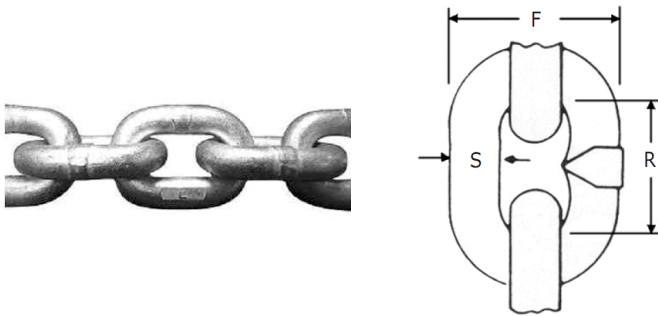

## Product Specifications

Name	ITEM #	Size (mm)	WLL (tonnes)	S (mm)	R (mm)	F (mm)	Weight per m (kg)
Grade L Chain 6mm Galvanised	14636	6	0.4	6.3	18.8	21.6	0.91
Grade L Chain 8mm Galvanised	14366	8	0.64	8	23.8	27	1.47
Grade L Chain 10mm Galvanised	12553	10	1	10	29.8	34.3	2.31
Grade L Chain 13mm Galvanised	14569	13	1.7	13	38.8	44.6	3.59
Grade L Chain 16mm PWB Galvanised	19454	16	2.58	16	47.8	54.9	5.71
Grade L Chain 20mm Galvanised	13161	20	4.03	20	59.2	68.5	9
Grade L Chain 22mm Galvanised	15629	22	5.06	22	64.9	77	10.86

Uncontrolled version printed 09-Mar-2018 .See [www.nobles.com.au](http://www.nobles.com.au) for latest up-to-date product information.

## Proof Coil Chain

Manufactured from a low grade carbon steel, this versatile range of chain is proof tested to at least twice the maximum load recommended for normal use.

Chain sizes 6mm to 24mm manufactured in Australia.

Proof Coil Chain is not suitable for industrial lifting purposes.

Test certificates available on request.

The MWL stated is for guidance in the selection of a chain with sufficient strength for intended applications.

Dimensions and masses subject to commercial tolerances and design changes without notice.

Applications: Manufacturing, marine and agricultural industries.

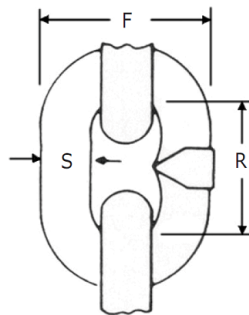

## Product Specifications

Name	ITEM #	Size (mm)	MWL (tonnes)	S (mm)	R (mm)	F (mm)	Weight per m (kg)
Proof Coil Chain Regular Link 3mm Galvanised	10664	3	0.06	3	16.6	13.1	0.17
Proof Coil Chain Regular Link 4mm Galvanised	14661	4	0.11	3.8	19.6	15.8	0.27
Proof Coil Chain Regular Link 5mm Galvanised	10540	5	0.19	4.75	23.2	19.1	0.42
Proof Coil Chain Regular Link 6mm Galvanised	19068	6	0.32	6	28	24	0.73
Proof Coil Chain Regular Link 8mm Galvanised	11400	8	0.53	7.6	35.8	29.2	1.14
Proof Coil Chain Regular Link 10mm Galvanised	11618	10	0.86	9.5	43.4	35.5	1.73
Proof Coil Chain Regular Link 13mm Galvanised	15061	13	1.5	12	51.7	44.5	2.89
Proof Coil Chain Regular Link 16mm Galvanised	17186	16	2.31	16	59.6	57.3	5.37
Proof Coil Chain Regular Link 20mm Galvanised	12366	20	3.67	20	73.3	71	8.33
Proof Coil Chain Regular Link 24mm Galvanised	16744	24	5.34	24	87	84.8	11.9

Uncontrolled version printed 09-Mar-2018 .See [www.nobles.com.au](http://www.nobles.com.au) for latest up-to-date product information.

## Commercial Chain Packs

Nobles commercial chain is our basic economical chain product for general purpose non-lifting applications. Available here in convenient 50kg pail packs.

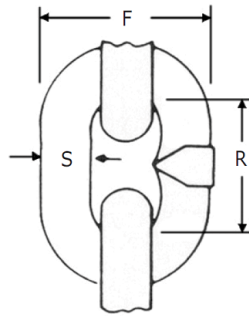

## Product Specifications

Name	ITEM #	Size S (mm)	R (mm)	F (mm)	Qty per pack (m)	Pail Pack Weight (kg)
Commercial Chain 4mm Galvanised ~160m 50kg Drum Pack	17567	4	18.6	16	152.5	50
Commercial Chain 5mm Galvanised ~115m 50kg Drum Pack	14079	5	22	19.4	96.5	50
Commercial Chain 6mm Galvanised ~66m 50kg Drum Pack	18656	6	26.1	23.5	60	50
Commercial Chain 8mm Galvanised ~43m 50kg Drum Pack	18684	8	32.2	29.5	37	50
Commercial Chain 10mm Galvanised ~28m 50kg Drum Pack	11439	10	39.1	36.2	23.5	50
Commercial Chain 13mm Galvanised ~14m 50kg Drum Pack	15248	13	49.1	46.1	13.9	50

Uncontrolled version printed 09-Mar-2018 .See [www.nobles.com.au](http://www.nobles.com.au) for latest up-to-date product information.

## Commercial Chain

Nobles commercial chain is our basic economical chain product for general purpose non-lifting applications. Available in 500kg bulk packs or per m. Minimum cut lengths apply.

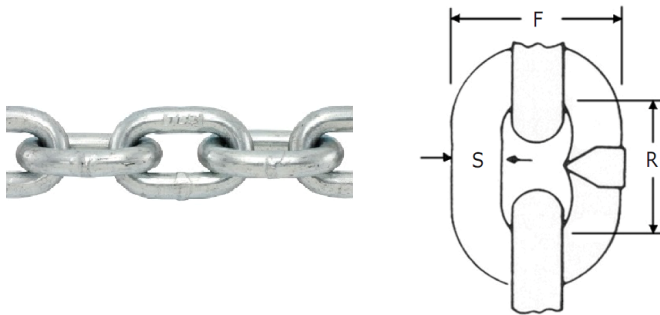

## Product Specifications

<b>Name</b>	<b>ITEM #</b>	<b>Size S (mm)</b>	<b>R (mm)</b>	<b>F (mm)</b>	<b>Weight (kg/m)</b>
Commercial Chain 3mm Galvanised	13260	3	15.7	13.1	0.2
Commercial Chain 4mm Galvanised	16667	4	18.6	16	0.33
Commercial Chain 5mm Galvanised	14551	5	22	19.4	0.518
Commercial Chain 6mm Galvanised	14081	6	26.1	23.5	0.83
Commercial Chain 8mm Galvanised	14106	8	32.2	29.5	1.35
Commercial Chain 10mm Galvanised	12791	10	39.1	36.2	2.12
Commercial Chain 13mm Galvanised	17931	13	49.1	46.1	3.61
Commercial Chain 16mm Galvanised	11145	16	59.6	56.5	5.49
Commercial Chain 20mm Galvanised	16817	20	73.3	70	8.62
Commercial Chain 24mm Galvanised	12441	24	87	83.6	12.43

Uncontrolled version printed 09-Mar-2018 .See [www.nobles.com.au](http://www.nobles.com.au) for latest up-to-date product information.

## Split Links

Split links are used as a means of joining commercial chain. They can be tack welded after closing if desired. Split links have no rated capacity and should not be used for lifting.



## Product Specifications

<b>Name</b>	<b>ITEM #</b>	<b>Size (mm)</b>	<b>Overall Length (mm)</b>	<b>Inside Width (mm)</b>	<b>Weight (kg)</b>
Split Link 4mm Galvanised	13904	4	19	8.5	0.006
Split Link 5mm Galvanised	13352	5	25	10.5	0.014
Split Link 6mm Galvanised	10624	6	38	12.5	0.036
Split Link 8mm Galvanised	19382	8	38	16	0.06
Split Link 10mm Galvanised	11836	10	50	19	0.11
Split Link 13mm Galvanised	17920	13	64	27	0.255

Uncontrolled version printed 09-Mar-2018 .See [www.nobles.com.au](http://www.nobles.com.au) for latest up-to-date product information.

## Trailer Safety Chain

"A chain attached between the drawbar and the towbar for the purpose of retaining connection between the towing vehicle and the trailer in the event of couple failure" Standards Australia AS 4177.4

Manufactured in Australia, for use with trailers of up to 3500kg aggregate trailer mass.

NOT suitable for lifting purposes

Manufactured to comply with Australian Standard 4177.4

Shackles used in conjunction with Safety Chains complying with AS 4177.4

Nobles confirms that the proposed combination of trailer safety chain as per AS 4177.4 and quality Grade 'S' rated 0.5 tonnes, 0.75 tonnes and 1.0 tonnes (WLL) shackles as per AS 2741 are satisfactory to use as a connection point between trailer safety chain and the tow bar of a towing vehicle.

6mm Grade S Dee and Bow 0.5t (or above) shackles are suitable for trailers up to 1600kg aggregate trailer mass.

8mm Grade S Dee and Bow 0.75t (or above) shackles are suitable for trailers up to 2500kg aggregate trailer mass.

10mm Grade S Dee and Bow 1.0t (or above) shackles are suitable for trailers up to 3500kg aggregate trailer mass.

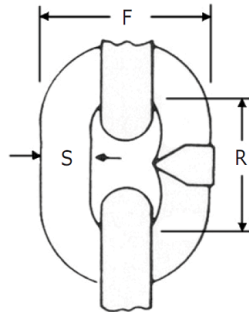

## Product Specifications

Name	ITEM #	Size (mm)	MWL (tonnes)	S (mm)	R (mm)	F (mm)	Weight per m (kg)
Trailer Chain 8mm Self Coloured	13479	8	1.6	7.6	43.5	31	1.07
Trailer Chain 8mm Quality Inspected Galvanised	22362	8	1.6	7.6	43.5	31	1.09
Trailer Chain 10mm Self Coloured	12093	10	2.5	9.5	53.1	39	1.63
Trailer Chain 10mm Galvanised	13029	10	2.5	9.5	53.1	39	1.67
Trailer Chain 13mm Self Coloured	17140	13	3.5	12	51.7	44.5	2.82
Trailer Chain 13mm Galvanised	14800	13	3.5	12	51.7	44.5	2.89

Uncontrolled version printed 09-Mar-2018 .See [www.nobles.com.au](http://www.nobles.com.au) for latest up-to-date product information.

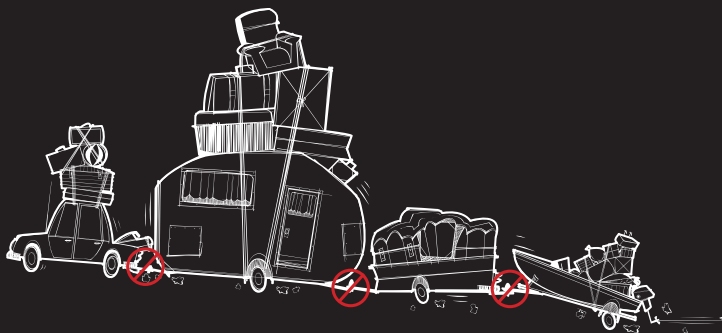

**IS YOUR  
CHAIN UP TO  
STANDARD?**

**PWB  
ANCHOR**  
The lifting equipment specialists



## Mining Suspension Chain

Mining Suspension Chain is manufactured in Australia from low grade carbon steel and is available in limited sizing from Regular or Long Link configurations. Suitable for the suspension of pipes or ducting, it is proof loaded to at least twice its maximum working load and supplied in a galvanised finished in minimum pallet lots.

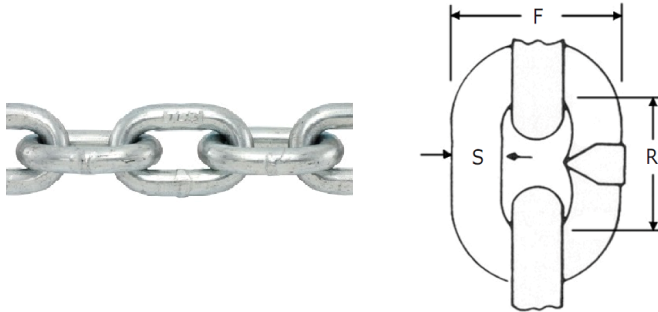

## Product Specifications

Name	ITEM #	Size (mm)	MWL (tonnes)	S (mm)	R (mm)	F (mm)	Weight per m (kg)
8mm GALVANISED REGULAR LINK MINING SUSPENSION CHAIN	19789	8	0.53	7.6	43.4	35.5	1.73
8mm GALVANISED SHORT LINK MINING SUSPENSION CHAIN	21518	8	0.64	8	23.8	27.8	1.47
Mining Suspension Chain 10mm Galvansied LL x 2.5m	27592	10	0.75	9.5	53.1	39	1.67
13mm GALVANISED SHORT LINK MINING SUSPENSION CHAIN	20257	13	1.7	12.7	38.2	45.2	3.61

## Stainless Chain Reg Link

The standard range of Stainless Steel Chain is manufactured from Type 316 Stainless which is highly resistant to corrosion in acid and alkaline, as well as salt water and marine environments.

Applications for stainless steel chain include stabilizer chains, netting ground chain and trawl board chains.

Nobles also have Type 304 Stainless Steel chain available on request. 304 grade chain is available in 6 - 13mm in regular and short link. Link dimensions and MWL are identical to 316 grade but 304 grade chain is supplied unpolished.

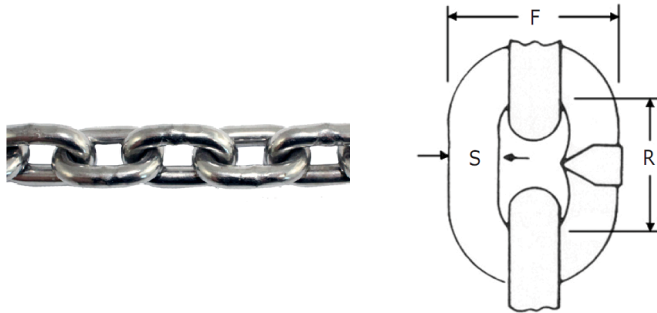

## Product Specifications

Name	ITEM #	Grade	Chain Size (mm)	MWL (tonnes)	S (mm)	R (mm)	F (mm)	Weight per m (kg)
S/S Chain 4mm Regular Link Gr316	18384	316	4	0.2	4	20.1	15.8	0.32
S/S Chain 6mm Regular Link Gr316	10328	316	6	0.45	6.3	26.2	23.5	0.5
S/S Chain 8mm Regular Link Gr316	16676	316	8	0.8	8	32.2	29.5	1.4
S/S Chain 10mm Regular Link Gr316	10773	316	10	1.25	10	39.2	36.2	2.3
S/S Chain 13mm Regular Link Gr316	13011	316	13	2.12	13	49.2	46.2	3.8

## Stainless Chain Short Link

The standard range of Stainless Steel Chain is manufactured from Type 316 Stainless which is highly resistant to corrosion in acid and alkaline, as well as salt water and marine environments.

Applications for stainless steel chain include stabilizer chains, netting ground chain and trawl board chains.

Nobles also have Type 304 Stainless Steel chain available on request. 304 grade chain is available in 6 - 13mm in regular and short link. Link dimensions and MWL are identical to 316 grade but 304 grade chain is supplied unpolished.

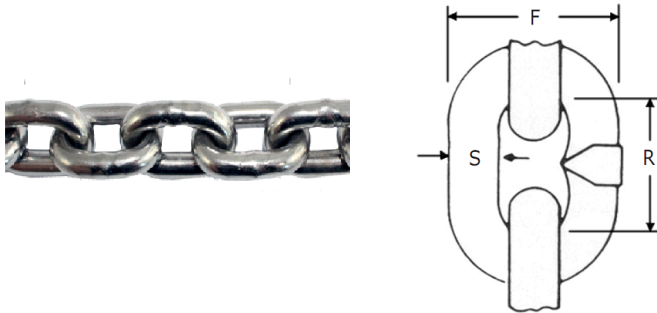

## Product Specifications

Name	ITEM #	Grade	Chain Size (mm)	MWL (tonnes)	S (mm)	R (mm)	F (mm)	Weight per m (kg)
S/S Chain 6mm Short Link Gr316	11795	316	6	0.45	6.3	18.9	21.5	0.87
S/S Chain 8mm Short Link Gr316 In Full Meter Length	10813	316	8	0.8	8	24	27.5	1.42
S/S Chain 10mm Short Link Gr316	10155	316	10	1.25	10	30	33.5	2.17
S/S Chain 13mm Short Link Gr316	16740	316	13	2.12	13	38.9	45	3.54

Uncontrolled version printed 09-Mar-2018 .See [www.nobles.com.au](http://www.nobles.com.au) for latest up-to-date product information.

## Stud-Link Chain & Fittings

Nobles can supply a full range of stud-link chain products and fittings. Chain specifications include Grade 2, Grade 3 and offshore mooring chain grade. Stud-link chain is also available with varying certification depending on requirements or application.



## STUD LINK CHAIN & FITTINGS

Nobles can supply a full range of stud-link chain products and fittings. Chain specifications include Grade 2, Grade 3 and offshore mooring chain grade. Stud-link chain is also available with varying certification depending on requirements or application.



### Stud Link Chain (Metric) Proof & Breaking Loads in kN

Chain Size (mm)	Anchor Chain for Vessels				Offshore Mooring Chain						Approx Weight of Chain (kgs/m)
	Grade 2		Grade 3		ORQ		Grade 4		GW5		
	Proof Load kN	Break Load kN	Proof Load kN	Break Load kN	Proof Load kN	Break Load kN	Proof Load kN	Break Load kN	Proof Load kN	Break Load kN	
16	107	150									6
17.5	127	179									7
19	150	211	211	301							8
20.5	175	244	244	349	249	376	385	490			10
22	200	280	280	401	286	431	442	562			11
24	237	332	332	476	339	511	524	667			13
26	278	389	389	556	397	598	612	779			15
28	321	449	449	642	458	691	707	900			18
30	368	514	514	735	524	790	809	1030			21
32	416	582	582	832	578	880	917	1170	1100	1404	22
34	467	655	655	936			1030	1310	1236	1572	25
36	522	731	731	1049			1150	1460	1380	1752	28
38	580	812	812	1157	822	1245	1280	1630	1536	1956	31
40	640	896	896	1285			1410	1790	1692	2148	35
42	703	980	980	1402	960	1446	1550	1970	1860	2364	38
44	768	1079	1079	1540	1108	1690	1690	2150	2028	2580	41
46	836	1167	1167	1677			1840	2340	2208	2808	45
48	908	1275	1275	1814	1268	1922	2000	2550	2400	3060	49
50	980	1373	1373	1961	1432	2171	2160	2750	2592	3300	55
52	1056	1476	1476	2111	1508	2273	2330	2970	2796	3564	59
54	1134	1585	1585	2268	1620	2441	2500	3180	3000	3816	64
56	1215	1698	1698	2429	1735	2615	2680	3410	3216	4092	69
58	1298	1814	1814	2595	1854	2794	2860	3640	3432	4368	74
60	1383	1933	1933	2766	1976	2978	3040	3870	3648	4644	79
62	1471	2056	2056	2941	2101	3166	3240	4120	3888	4944	84
64	1561	2182	2182	3121	2230	3360	3430	4380	4116	5256	90
66	1653	2311	2311	3306	2361	3559	3640	4630	4368	5556	95
68	1747	2443	2443	3495	2496	3762	3850	4900	4620	5880	101
70	1844	2578	2578	3688	2634	3970	4060	5170	4872	6204	107
73	1993	2786	2786	3986	2847	4291	4390	5580	5268	6696	117
76	2146	3001	3001	4293	3066	4621	4730	6010	5676	7212	126
78	2251	3147	3147	4503	3216	4847	4950	6310	5940	7572	133
81	2412	3373	3373	4825	3446	5194	5320	6760	6384	8112	144
84	2578	3604	3604	5156	3683	5500	5680	7230	6816	8676	155
87	2747	3841	3841	5495	3925	5916	6050	7700	7260	9240	166
90	2921	4084	4084	5842	4173	6289	6440	8190	7728	9828	177
92	3039	4249	4249	6078	4342	6544	6690	8520	8028	10224	185
95	3219	4501	4501	6439	4599	6932	7090	9030	8508	10836	198
97	3342	4671	4671	6683	4774	7195	7360	9370	8832	11244	206
100	3528	4932	4932	7056	5040	7596	7770	9890	9324	11868	219
102	3654	5108	5108	7308	5220	7868	8040	10240	9648	12288	228

## STUD LINK CHAIN & FITTINGS cont.

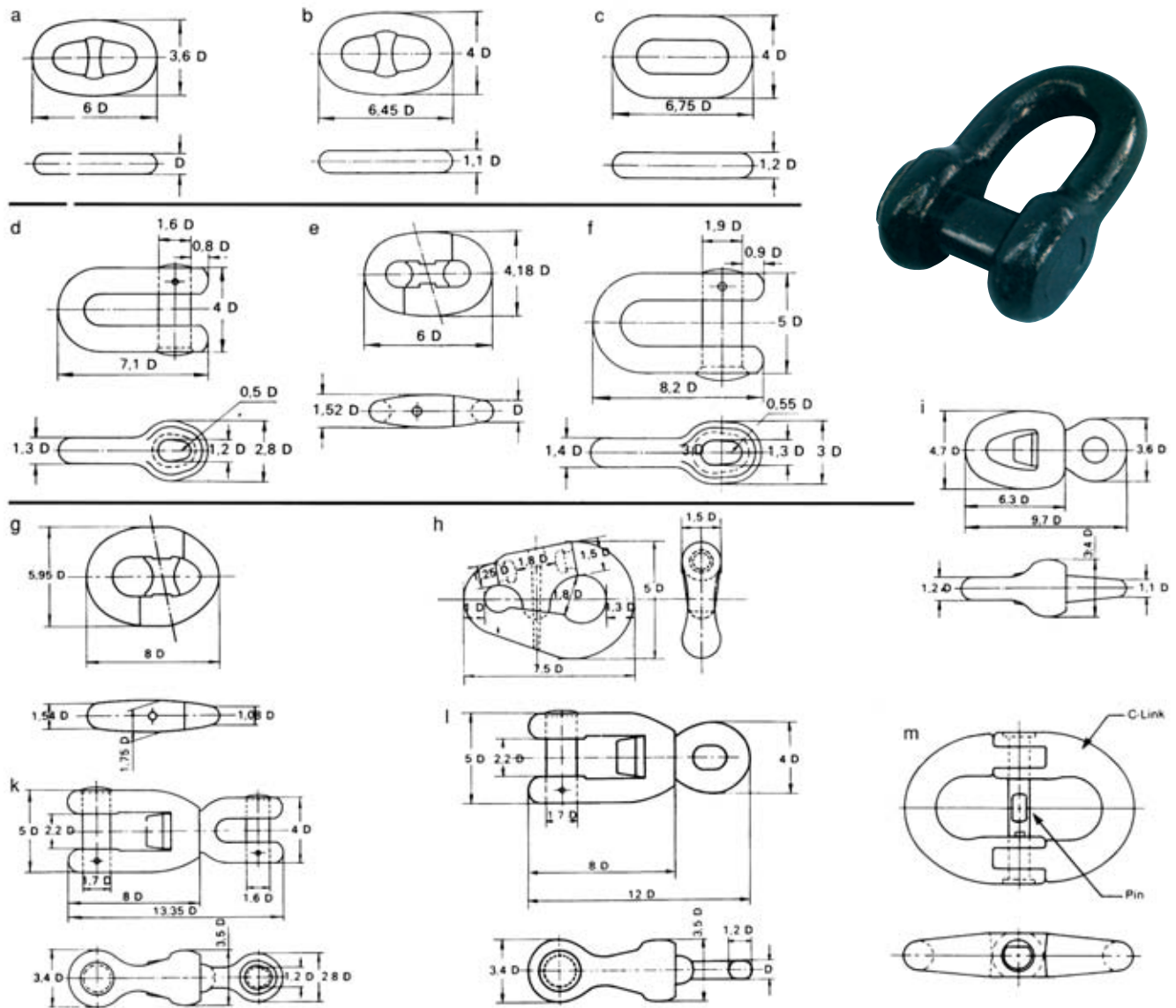

General Purpose & Mooring Chain

### Details of Stud Link Anchor Chain and Fittings

- |                                   |  |
|-----------------------------------|--|
| <b>a</b> = Common link            | <b>g</b> = Anchor shackle type Kenter  |
| <b>b</b> = Enlarged link          | <b>h</b> = Anchor shackle, pear shaped |
| <b>c</b> = End link               | <b>i</b> = Swivel, normal type         |
| <b>d</b> = Joining shackle type D | <b>k</b> = Swivel shackle with bolt    |
| <b>e</b> = Kenter joining shackle | <b>l</b> = Swivel shackle with eye     |
| <b>f</b> = Anchor shackle type D  | <b>m</b> = Hinge link                  |



# Contact Us

---



1300 711 559



[sales@nobles.com.au](mailto:sales@nobles.com.au)

EC 016799 | PGE 207647