

Specifications

Model	Z-33/18	
Measurements	US	Metric
Working height maximum*	38 ft 10 in	12 m
Platform height maximum	32 ft 10 in	10 m
Horizontal reach maximum	18 ft 3 in	5.57 m
Up and over clearance maximum	14 ft 1 in	4.28 m
A Platform length	2 ft 6 in	0.76 m
B Platform width	3 ft 10 in	1.17 m
C Height - stowed	6 ft 6 in	1.98 m
D Length - stowed	13 ft 8 in	4.17 m
E Width	4 ft 11 in	1.50 m
F Wheelbase	6 ft 3 in	1.90 m
G Ground clearance - center	6.0 in	15.2 cm

Productivity

Lift capacity	440 lb	200 kg
Turntable rotation	400° non-continuous	
Turntable tailswing at counterweight	zero	zero
Turntable tailswing - riser up	5.2 in	0.15 m
Turntable tailswing - riser down	3 ft 10 in	1.16 m
Drive speed - stowed	3.2 mph	5.2 km/h
Drive speed - raised retracted**	0.54 mph	0.87 km/h
Drive speed - raised extended**	0.14 mph	0.23 km/h
Gradeability - stowed***	30%	
Turning radius - inside	6 ft 3 in	1.9 m
Controls	24V DC proportional	
Tires (solid rubber, non-marking, treaded)	22x9x17 in	56x23x43 cm

Power

Power source	48 V DC (eight 6 V X 8 batteries 350 Ah capacity)	
Drive system	AC Drive, 48V 3 phase	
Auxiliary power unit	24 V DC	24 V DC
Hydraulic tank capacity	6 gal	20.8 L

Weight****

	8,080 lb	3,665 kg
--	----------	----------

Standards Compliance

ANSI A.92.20; CSA B354.6, EN 280, AS 1418.10

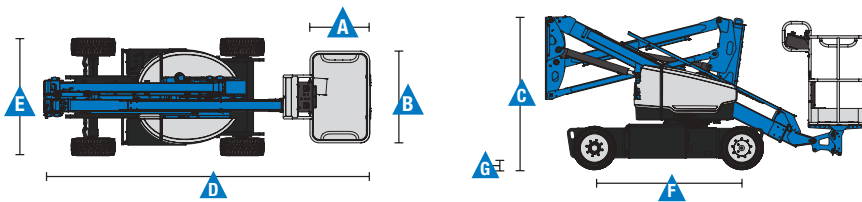

* The metric equivalent of working height adds 2 m to platform height. U.S. adds 6 ft to platform height.
 ** In lift mode (platform raised), the machine is designed to operate on firm, level surfaces only.
 *** Gradeability applies to driving on slopes. See operator's manual for details regarding slope ratings.
 **** Weight will vary depending on options and/or country standards.

Range Of Motion Z-33/18

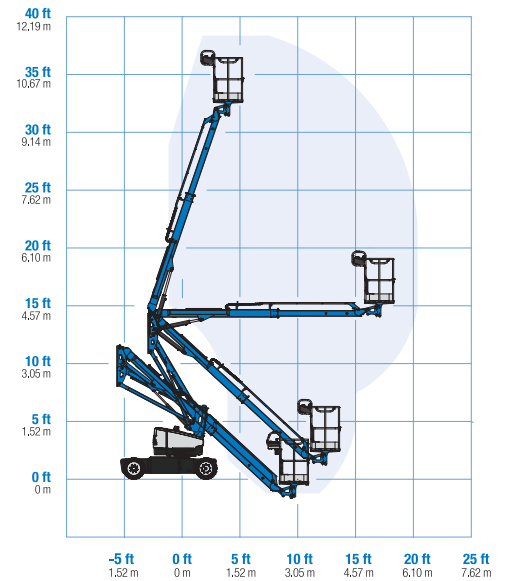

Features

Standard Features

Measurements

- 38 ft 10 in (12 m) working height
- 18 ft 3 in (5.57 m) horizontal reach
- 14 ft 1 in (4.28 m) up and over clearance
- Up to 440 lb (200 kg) lift capacity with up to two occupants

Productivity

- 4 ft 11 in (1.50 m) width
- 6 ft 3 in (1.9 m) inside turning radius
- Self-leveling platform
- Fast Mast™ System
- Proportional joystick controls
- Thumb rocker steer
- Drive enable
- Alarm package: flashing beacon and travel alarm
- Horn
- Hour meter
- Tilt alarm
- Descent alarm
- 400° non-continuous turntable rotation
- AC electric drive system
- Traction control
- On board easy to understand diagnostics
- AC power cord to platform
- Entry toe board

Power

- 48 V DC deep cycle battery pack
- 24 V DC auxiliary power
- Universal 30A battery smart charger
- Battery charge indicator
- Low battery voltage interrupt

Easily Configured To Meet Your Needs

Platform

- Aluminum 3 ft 10 in (1.17 m) with sliding mid-rail

Power

- 48 V DC (eight 6 V 350 Ah batteries)

Drive

- 2WD, AC Electric

Tires

- Solid rubber non-marking

Options & Accessories

Productivity

- Air line to platform*
- Work lights package (2 on chassis, 2 on platform)
- Lockable platform control box cover
- Biodegradable hydraulic oil



* Factory fit option only

Genie United States

6464 185th Ave. NE
Redmond, WA 98052
Telephone +1 (425) 881-1800
Toll Free in USA/Canada +1 (800)-536-1800
Fax +1 (425) 883-3475

Distributed By:

Effective Date: January, 2019. Product specifications and prices are subject to change without notice or obligation. The photographs and/or drawings in this document are for illustrative purposes only. Refer to the appropriate Operator's Manual for instructions on the proper use of this equipment. Failure to follow the appropriate Operator's Manual when using our equipment or to otherwise act irresponsibly may result in serious injury or death. The only warranty applicable to our equipment is the standard written warranty applicable to the particular product and sale and we make no other warranty, express or implied. Products and services listed may be trademarks, service marks or trade names of Terex Corporation and/or their subsidiaries in the USA and many other countries. Terex, Genie and AWP are registered trademarks of Terex Corporation or its subsidiaries. © 2019 Terex Corporation.