



StrataGreen
...grow with us

LANDSCAPE EQUIPMENT DIRECTORY

.....
EDITION 9

CORE VALUES

SERVICE

Our team genuinely cares for people and demonstrates empathy, understanding that our customers are more than just transactions; they're people with unique needs and concerns.

DRIVEN

Our drive to succeed sets us apart from the competition, and we are committed to delivering results that exceed our client's expectations.

POSITIVE

Maintaining a positive outlook is vital to overcoming obstacles and achieving our goals.

TEAMWORK

We know that working collaboratively with others is essential to achieving success.

PROACTIVE

Whether finding new ways to streamline our processes or developing innovative new products, we are always looking for ways to be more proactive and achieve even greater success.

INTEGRITY

Integrity is essential to building solid and lasting relationships with our customers, partners, and colleagues, and we work hard to maintain the highest standards of honesty, transparency, and ethical behaviour.

LEADERSHIP

We are committed to developing strong, influential leaders who can help us create a brighter future for our organisation and customers.

AMENDABLE

We know that amenability is essential to creating a positive and productive work environment, and we work hard to foster a culture of openness and collaboration.

RELIABLE

Our team members are committed to delivering on their promises and going the extra mile to ensure our customers are satisfied with our products and services.

Your one-stop-shop:

With over two decades in the industry, StrataGreen has established itself as a leading comprehensive supplier across Australia's landscaping, environmental, horticultural, and construction sectors. Their extensive inventory, exceeding 3,000 products, is housed in warehouses in Perth, Western Australia and Sydney, New South Wales.

Biggest range ever

StrataGreen prides itself on offering a diverse range of quality supplies, from essentials for urban tree and root control to nursery and plant propagation, erosion control, revegetation, soil improvement, and much more. StrataGreen's passionate team is dedicated to enhancing customer projects. They provide expert advice, quality products, and solutions tailored to landscaping professionals, contractors, and councils. This commitment to customer success and project excellence is the cornerstone of their service, ensuring you can trust them to deliver the best results for your projects. StrataGreen is the exclusive Australian distributor of TerraCottem® soil conditioner, and the creator of Formline® landscape edging, and Rhinoweld welded mesh gabions.



MEET OUR TEAM



RICK SHARPE

Director



TIM SHARPE

Sales Director



SELBY SHARPE

Showroom Consultant



AMELIA ROBINSON

Marketing Specialist

Each person in the StrataGreen team has a positive, friendly, can-do attitude. Everyone shares the same aim, to help StrataGreen's customers find what they need to finish each project well. It's this shared respect for others that benefits everyone, and it's why StrataGreen has been successfully in business for so many years. Speak to anyone of the team and you'll appreciate how genuine these people are.



PHIL HOUSTON

National Sales Manager



BENETTA LOBO

Senior Customer Development Manager



ALASKAH TREWARN

Business Development Manager



LACHLAN HOWE

Business Development Manager

MEET OUR TEAM



HANNAY GILKISON

Accounts



GAVIN FAWKES

RTO Manager



ROY FLINTOFF

National Operations Manager



BLAISE NATHAN

Showroom Consultant



REUTHER LOZARES

Store Person



TIM VANGESTEL

Store Person



SEAN BRIDEWELL

Store Person



CALLUM MOORE

Store Person

8 Reasons to buy off StrataGreen

1. KNOWLEDGE

With over 30 years of experience in the landscape industry, we've seen it all—and we're here to help. Whether it's selecting the right product for a tricky erosion issue or choosing the perfect blade for your pruning saw, our knowledgeable team is just a call or click away.

2. FAST DELIVERY

We know timing is everything. That's why over 98% of our orders are packed and dispatched within 24 hours from our WA warehouse—so you get what you need, when you need it.

3. HUGE RANGE

With more than 3,000 products in stock and ready to go, we've got you covered. From tools and soil solutions to tree guards and irrigation gear, our extensive range is ready for nationwide dispatch.

4. CUSTOMER SERVICE

At StrataGreen, you come first. Our team prides itself on fast, friendly service and genuine advice—whether you're placing a big order or just need help finding the right solution for your project.

5. FAMILY OWNED

Proudly Western Australian and family-owned, StrataGreen has been supporting landscapers for more than three decades. We're a father-and-sons business with a passion for quality and service.

6. EASY ONLINE ORDERING

Need to order on the go? Our website makes it simple to find what you need, check live stock levels, and place your order—anytime, anywhere.

7. RELIABLE

You can count on us. With over 30 years of experience in the landscaping industry, we've built a reputation for being dependable, knowledgeable, and ready to support your project—no matter the size or challenge.

8. SWEET EXTRAS

Need your order in a hurry or after that one hard-to-find item? We're here to help—and we like to sweeten the deal with free lollies and exclusive merch on qualifying online orders.



CONTACT US



WESTERN AUSTRALIA

Office & Warehouse

Monday to Friday
7:30am - 5:00pm AWST

5 Barrel Way
Canning Vale WA 6155

1300 866 367

WESTERN AUSTRALIA

Office & Warehouse

Monday to Friday
7:30am - 5:00pm AEST

Unit 2 20 Rigali Way
Wangara WA 6065

1300 866 367

NEW SOUTH WALES

Office & Warehouse

Monday to Friday
7:30am - 5:00pm AEST

1/14 Weld Street
Prestons NSW 2170

1300 866 367

FOR ORDERS EMAIL
sales@stratagreen.com.au



TABLE OF CONTENTS

Urban Trees and Root Control	SECTION 1	13
Landscape Edging	SECTION 2	27
Gabions	SECTION 3	41
Erosion Control	SECTION 4	49
Nursery and Plant Propagation	SECTION 5	55
Revegetation and Tree Planting	SECTION 6	65
Geosynthetic and Drainage Products	SECTION 7	77
Soil Improvement and Watering	SECTION 8	85
Weed and Pest Control	SECTION 9	113



Pruning Tools	SECTION 10	133
Multi Tools and Knives	SECTION 11	157
Tool Accessories	SECTION 12	161
Landscaping Tools	SECTION 13	165
Spraying Equipment	SECTION 14	185
Power Equipment Accessories	SECTION 15	193
Safety and Marking	SECTION 16	197
Protective Equipment	SECTION 17	207



What our Customers Say



“

We want to also extend our gratitude in regards to getting the brush and stakes delivered so quick. Much appreciated.

- Karl

”

“

At Bridgetown-Greenbushes Community Landcare we have always had fantastic service from Tim and the staff at StrataGreen whether it is from his visits down south to email and phone queries and the follow-up prompt deliveries of anything we have ordered, we'd highly recommend this company to any.

- Karrie

”

“

I find your company is always very efficient to deal with and I receive my goods in an extremely timely manner.

- Marina

”

“

Gavin and the team provide great advice, fast responses, and delivery on time. I highly recommend StrataGreen to any Landscaping company that is after a convenient one stop shop for your supplies.

- Daniel

”

“

We purchased a heap of gabions and metal edging from these guys for a landscaping project. We were very happy with the prompt service and good advice, and the friendly blokes in the warehouse. Will definitely be back when we are onto the next project.

- Lachie

”

“

Keep up the good work. It can be challenging dealing from Esperance and your company makes that a satisfying experience.

- Andrew

”

“

Awesome team that is a pleasure to deal with, couldn't recommend more highly.

- Barry

”

“

I have visiting for over 25 years since they were in Kewdale. Always have or can order what I need. Always a nice packet of lollies for the trip home. Well stocked with all the things my Arboricultural business needs.

- Garry

”

“

Keep up the good work, happily use StrataGreen as a supplier into the future

- Samuel

”



LANDSCAPE EDGING



Shape something beautiful.™



SECTION 1

URBAN TREES AND
ROOT CONTROL

REROUTE RIBBED ROOT BARRIER

PRODUCT CODE

RER300 - ReRoute 300

30m roll, 300mm deep, 1.0mm thick

RER600 - ReRoute 600

30m roll, 600mm deep, 1.0mm thick

ReRoute™ Ribbed Root Barriers are designed to effectively manage root growth and protect surrounding infrastructure. Manufactured from high-density polyethylene, each barrier features moulded vertical ribs that guide roots downward and away from paths, kerbs, and underground services. Available in 300mm and 600mm deep rolls, ReRoute is ideal for new tree installations or retrofitting around existing plantings. The flexible yet rigid design makes installation easy without the need for specialist tools, while the ribbed structure helps prevent root swirl and encourages healthy, directed root growth. When joining roll ends, Root Barrier Joining Tape should be used to ensure a secure, root-proof seal.



ROOTDEFLECTOR™ DIMPLED BARRIER

PRODUCT CODE

RSNI600

600mm deep, 30m roll, 1.0mm thick

RSNI1000

1,000mm deep, 30m roll, 1.0mm thick

RootDeflector™ is a cusped (or dimpled) root barrier commonly used in tree planting and root management applications. While vertically ribbed barriers are often preferred for their superior redirection of root growth, RootDeflector remains a trusted option across the industry. Supplied in 30-metre rolls and available in 600mm and 1,000mm depths, this high-density barrier helps deflect roots away from critical infrastructure and services. It is ideal for retrofitting around existing trees or use during pavement reinstatement works. The material is easy to install without specialist tools, and ReRoute Joining Tape can be used to create a secure, root-proof seal when joining sections.

ROOT BARRIER SUPER ADHESIVE JOINING TAPE

PRODUCT CODE

RST7230

72mm x 30mm per roll

Root Barrier Super Adhesive Joining Tape is designed to create a secure, long-lasting seal when joining two lengths of root barrier. Without proper joining, even overlapped barriers can allow roots to penetrate, leading to potential damage to services, pavements, or surrounding infrastructure. This 72mm wide tape provides strong, water-resistant adhesion that lasts for the life of the barrier. It's an essential component for ensuring a fully root-proof installation. Detailed installation instructions are available to guide proper application on site.





ROOTSTOP LINEAR BARRIER

RootStop Linear Barrier is a robust and long-lasting root control solution designed to prevent invasive root systems from encroaching into unwanted areas. Ideal for use alongside property boundaries, under pavement, near building foundations, or around underground services, RootStop provides an effective physical barrier while allowing unrestricted root growth in other directions. Manufactured from a specially formulated plastic that resists brittleness, degradation, and chemical leaching, it offers superior durability in below-ground environments. Its rigid construction ensures ease of installation in narrow trenches, whether machine-dug or manually prepared, making it a practical choice for long-term root management.

PRODUCT CODE	DESCRIPTION
RS500	500mm Wide, 50m Roll Length
RS600	600mm Wide, 50m Roll Length
RS1000	1,000mm Wide, 50m Roll Length

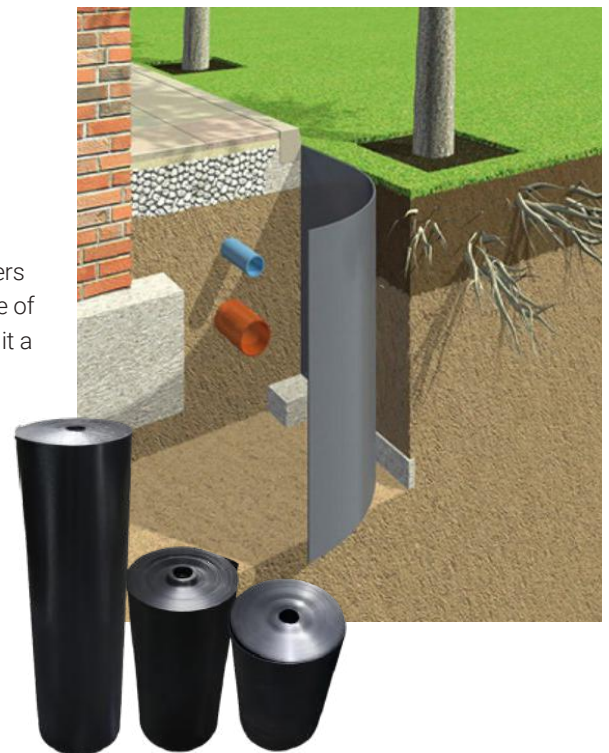

ROOT DIRECTOR

The Root Director is an in-ground system designed to protect pavements and hard landscape areas by guiding tree roots downward and outward from the planting zone. Its integrated ribs help prevent root girdling while encouraging deeper root growth, improving both drought tolerance and tree stability. Optional irrigation and aeration compartments promote efficient watering and draw roots further into the soil profile. The system also serves as a cost-effective foundation for supporting stakes and tree guards. Simple to install at the time of planting, the Root Director provides long-term protection and support for urban tree plantings.



PRODUCT CODE	TOP (mm)	BOTTOM (mm)	HEIGHT (mm)	OPENING (mm)
RDC600	600 dia	900 dia	400	600 dia
RDC900	900 dia	1,200 dia	400	900 dia

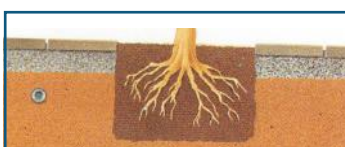

Without root management, tree roots in unprotected pits spread laterally, lifting paving and damaging infrastructure. Cutting these roots for repairs can destabilise or kill the tree.

Tree roots are guided downward and outward by the Root Director, encouraging deep growth away from paving. This enhances tree stability, drought tolerance, and prevents surface damage.

RIBBLESDALE TREE GRILLE

PRODUCT CODE

ASF306

Frame to suit: ASF004

Dimensions: 1,200mm x 1,200mm square

Opening Size: 450mm Ø

Material: Grade 250 Cast Iron

Finish: One coat metal primer and one coat Weathershield rust-resistant paint (RAL or BS colours)

Frame Compatibility: ASF004 Steel Frame (sold separately)

The Ribblesdale Tree Grille is a 1,200mm square cast iron grille with a 450mm central opening, designed to protect tree pits from pedestrian impact while allowing room for trunk growth. Made from Grade 250 cast iron and finished with a rust-resistant Weathershield paint system, it offers both durability and architectural appeal for streetscapes and public spaces. The ASF004 Steel Frame is recommended for installation and is sold separately.

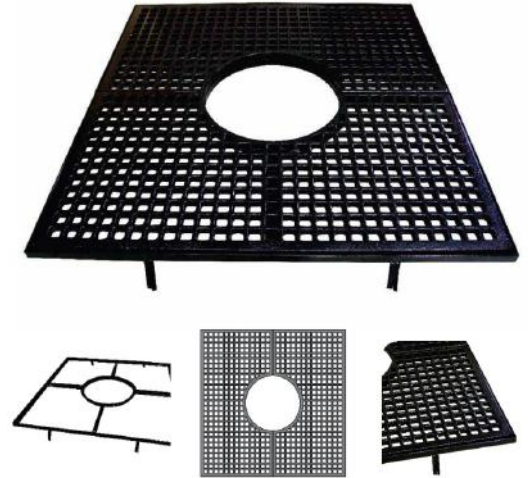

GARSDALE TREE GRILLE

PRODUCT CODE

ASF316

Frame to suit: ASF003

Dimensions: 1,200mm x 1,200mm square

Opening Size: 640mm Ø

Material: Grade 250 Cast Iron

Finish: One coat metal primer and one coat Weathershield rust-resistant paint (RAL or BS colours)

Frame Compatibility: ASF003 Steel Frame (sold separately)

The Garsdale Tree Grille is a robust and architecturally styled cast iron grille, designed to protect tree pits while allowing for healthy trunk growth in high-traffic urban environments. With a larger 640mm central opening, it's ideal for more mature or fast-growing trees. Manufactured from durable Grade 250 cast iron and finished with a rust-resistant paint system, the Garsdale is suited for public spaces, parks, footpaths, and streetscapes. Optional irrigation holes and security clips are available, and the grille should be installed with the ASF003 Steel Frame (sold separately).



COVERDALE TREE GRILLE

PRODUCT CODE

ASF310

Frame to suit: ASF002

Dimensions: 1,200mm x 1,200mm square

Opening Size: 440mm Ø

Material: Grade 250 Cast Iron

Finish: One coat metal primer and one coat Weathershield rust-resistant paint (RAL or BS colours)

Frame Compatibility: ASF002 Steel Frame (sold separately)

The Coverdale Tree Grille is a compact and durable solution for protecting young or smaller trees in urban landscapes. Made from Grade 250 cast iron, it features a 440mm central opening to accommodate trunk growth while shielding the surrounding soil from compaction. Finished with a rust-resistant paint system for long-term performance, the Coverdale is ideal for footpaths, parks, and public spaces. Optional irrigation holes and security clips are available, and the grille is designed to be installed with the ASF002 Steel Frame (sold separately).





ULTRAGRATE TREE GRATE 1050MM

PRODUCT CODE

UG1050

Dimensions: 1,080mm square x 64mm thick

Centre Opening: 385mm Ø

Material: UV-stabilised medium-density polyethylene

Stake Access: 4 knock-out sections in corners to fit hardwood stakes up to 50mm

Compatibility: Fits Duragal galvanised frame (UG1050F, sold separately)

Application: Suitable for pedestrian areas and light wheeled traffic zones

The Ultragrate Tree Grate is a versatile and cost-effective solution for protecting tree pits in pedestrian and light wheeled traffic areas. Made from UV-stabilised medium-density polyethylene, it allows for air and water infiltration while supporting trunk growth. Easy to install and adjust, the Ultragrate features cut-out sections for stakes and can be retrofitted around established trees. Designed to be secured to a Duragal galvanised frame (UG1050F, sold separately), it offers long-lasting durability in urban settings.

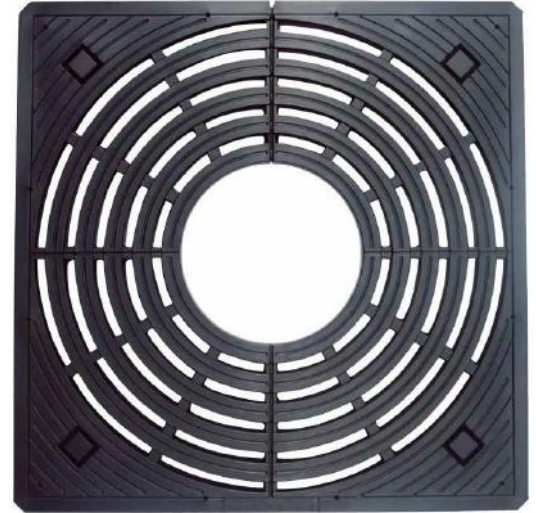

ULTRAGRATE TREE GRATE 640MM

PRODUCT CODE

UG640

Dimensions: 640mm square x 49mm thick

Centre Opening: 295mm Ø

Material: UV-stabilised medium-density polyethylene

Stake Access: 2 knock-out sections in opposite corners for hardwood stakes up to 50mm

Compatibility: Fits Duragal galvanised frame (UG640F, sold separately)

Application: Suitable for pedestrian areas and light wheeled traffic zones

The Ultragrate Tree Grate 640mm is a durable, lightweight, and economical option for protecting trees in high-foot-traffic areas such as footpaths, malls, and public spaces. Manufactured from UV-stabilised medium-density polyethylene, it provides vital root zone aeration and water infiltration while supporting healthy trunk growth. With a split-fit design for established trees and knock-out sections for staking, the Ultragrate is quick to install and is designed for use with the UG640F Duragal galvanised frame (sold separately).

GALVANISED FRAME FOR UG1050 & UG640

PRODUCT CODE

UG640F - to suit UG640

UG1050F - to suit UG1050

Material: Galvanised steel

Use: Designed to secure Ultragrate Tree Grates in place within concrete surrounds

Compatibility: UG1050F fits Ultragrate 1050mm; UG640F fits Ultragrate 640mm

Installation: Set in concrete for secure fitting of tree grates

The Ultragrate Galvanised Frames are designed to provide a secure and stable foundation for the UG1050 and UG640 Ultragrate Tree Grates. Manufactured for durability in urban conditions, these angle frames are set in concrete and allow the tree grates to be fixed in place, ensuring long-term performance in pedestrian and light traffic environments. Each frame is sold separately to suit its matching grate size.





GREEN PIT WATERING SYSTEM

The Green Pit Watering System is an efficient and targeted solution for delivering water directly to where it's needed – the root zone. Surface watering often leads to shallow root growth and damage to surrounding hardscapes, while also wasting water through run-off and evaporation. Green Pit ensures even and rapid distribution of water, nutrients, and oxygen around the root ball, promoting deeper, healthier root development and optimal tree growth. Water seeps out progressively during watering, allowing a large volume to reach the root zone in a short time.

- Fast and easy to install
- Saves time and money
- Encourages deeper root growth
- Reduces water waste from run-off and evaporation



PLEG65

65mm End Grate



GP200

Watering Inlet



GP200A - Alloy
Watering Inlet



PLPR6520

65mm Piping - 20m Slotted



PLT65

65mm T-Junction



The Green Pit Principle: Efficient Tree Irrigation



Surface irrigation is rarely efficient for trees. The topsoil becomes waterlogged, leading to run-off, soil capping, compaction, and water wastage. Water struggles to penetrate into the deeper root zone.



When the surface is irrigated frequently to a shallow depth, roots remain close to the surface, making the tree more susceptible to drought over time.

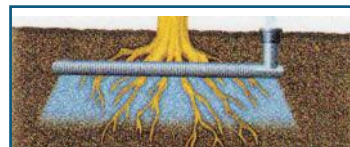

The Green Pit Watering System delivers water directly to the deep root zone, eliminating wastage and reducing the risk of surface compaction.

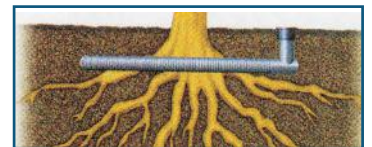

This encourages roots to grow deeper, improving long-term drought resistance and tree stability. It also provides access for aeration and the application of soluble fertilisers.



VERSIWALL™ GP

The VersiWall™ GP system by Elmich is a modular, low-maintenance green wall solution designed to transform plain surfaces into vibrant vertical gardens. Ideal for both new developments and retrofit projects, it offers flexible mounting and planting configurations to suit various wall conditions. Each tray includes a built-in water reservoir with capillary wick support, promoting water efficiency and healthy plant growth. Trays can be individually removed for easy maintenance or design changes, and the use of mounting frames reduces wall penetrations while allowing for simple, one-person installation. Made from UV-stabilised recycled polypropylene, the system supports sustainable building practices and meets green building certification standards.



PRODUCT CODE

VWGP

Planter Tray



PRODUCT CODE

VWGPP

Mounting Panel

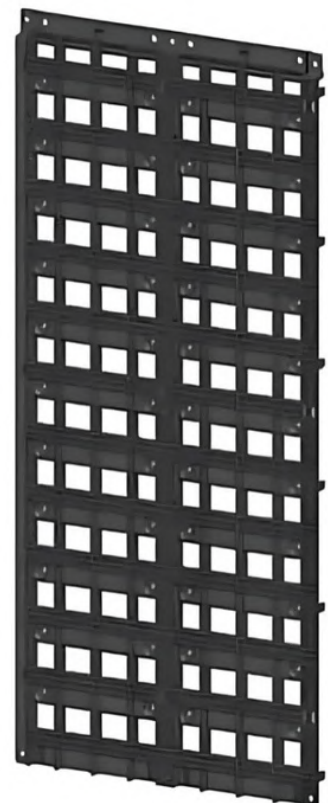

HULK TREE GUY KITS

HULK Tree Guy Kits provide a professional above-ground solution for securing newly planted or existing trees that require temporary stabilisation. Designed for fast, easy installation and unmatched holding strength, each ready-to-use kit includes guying assemblies with anchors, protective tree collars, wire rope grips, and an integral turnbuckle to finely adjust line tension during setup.

These kits are ideal for anchoring trees that require stabilisation higher up in the canopy, offering a clean, professional appearance and superior performance over traditional staking methods. Kits are available in a wide range of sizes to suit various applications and tree heights, including 3-leg and 4-leg variants for anchoring trees up to 12 metres tall. Specialist Palm Tree Kits are also available, complete with tailored collars for safe and effective guy-line attachment.

- Professional and unobtrusive appearance
- Superior holding capacity compared to conventional staking
- Quick and easy installation process
- Wide selection of kit sizes for different tree types and sizes
- Available in both 3-leg and 4-leg configurations
- Palm Tree Kits available with specialised tree collars



SELECTING THE RIGHT HULK TREE ANCHORING KIT

To ensure the correct HULK Tree Guy Kit is selected, it's important to understand the Tree Size Index – a measurement based on the AS 2303:2015 standard, which assesses tree proportions before planting.

The **Tree Size Index** is calculated by multiplying:

- Tree height (in metres) – measured from the top of the root ball to the highest point
- Calliper (in millimetres) – measured at 300mm above the root crown

Example:

Tree height = 3m

Calliper = 80mm

Size Index = 3 × 80 = 240

This Size Index helps determine the appropriate container size and, in turn, the correct HULK Tree Kit model. For instance, a tree with a Size Index of 240 is typically suited to a container volume of 200–250 litres. Conversely, a tree in a 200–250L container usually has a Size Index between 185 and 330. This allows for variation in tree proportions, meaning a tall narrow tree can have the same index as a short broad one.

Once the Tree Size Index is known, simply refer to the HULK specification tables to match your project with the correct Tree Guy Kit model by Tree Index and Planter Size.

TREE SIZE INDEX AS PER AS2303:2015

Nominal Container Volume in L	Size Index Range	Nominal Container Volume in L	Size Index Range
20	24-37	150	144-212
25	31-45	160	153-224
30	36-53	200	185-272
35	41-61	230	209-307
40	46-68	240	216-318
45	51-75	250	224-330
50	56-82	285	251-369
55	61-89	300	262-386
60	66-99	350	289-440
65	70-103	400	330-494
70	75-110	500	407-599
75	79-117	600	476-700
85	89-130	750	577-849
90	93-137	1000	739-1087
100	102-150	1200	865-1272
110	111-163	1500	1048-1975
130	128-188	2000	1343-1975
140	136-200	2500	1627-2393



EARTH ANCHOR TREE GUY KIT

With a HULK Earth Anchor Tree Guy Kit and a HULK Smasher Rod you have everything you need to professionally secure a newly planted tree. The included guy anchor assemblies are comprised of a HULK Earth Anchor attached to a wire rope guy line. The HULK Earth Anchor is driven and set into undisturbed soil. The supplied wire rope grips are used to fasten the guy line to the tree with protective tree collars to prevent damage. The integrated turnbuckle brings the system into tension to provide an anchoring solution with holding capacity, and neatness, far superior to stakes.

HULK EARTH ANCHOR UNDERGROUND TREE KITS				
Kit Model	Kit Contents	Anchor MBL	Max. Tree Index AS2303:2015	Max. Planter Size (L)
HP25TGK	3qty HULK HP25 Earth Anchors with fitted guy lines of 3mm x 4.5m wire rope. 3qty Stem protectors. 6qty 3mm wire rope grips.	6.85KN	224	250
HP35TGK	3qty HULK HP35 Earth Anchors with fitted guy lines of 4mm x 5.5m wire rope with turnbuckle. 3qty Stem protectors. 6qty 4mm wire rope grips.	11.2KN	1125	1000
H50TGK*	3qty HULK H50 Earth Anchors with fitted guy lines of 6mm x 6.5m wire rope with turnbuckle. 3qty Stem protectors. 9qty 6mm wire rope grips.	25.4KN	2393	2500
H80TGK*	3qty HULK H80 Earth Anchors with fitted guy lines of 6mm x 6.5m wire rope with turnbuckle. 3qty Stem protectors. 9qty 6mm wire rope grips.	25.4KN	2393	2500
H110TGK*	3qty HULK H110 Earth Anchors with fitted guy lines of 6mm x 6.5m wire rope with turnbuckle. 3qty Stem protectors. 9qty 6mm wire rope grips.	25.4KN	2393	2500

*Note: These kits have the same MBL, different anchor sizes cater for hard, medium and soft soils.
To order a kit in a 4 leg variant, add "4" to the above Kit Model Code.
E.g. HP35TGK4 for the 4 Leg Variant.

Kit capacity is soil dependant. One kit anchors one tree. HULK Smasher drive rod sold separately. Installation instructions included.

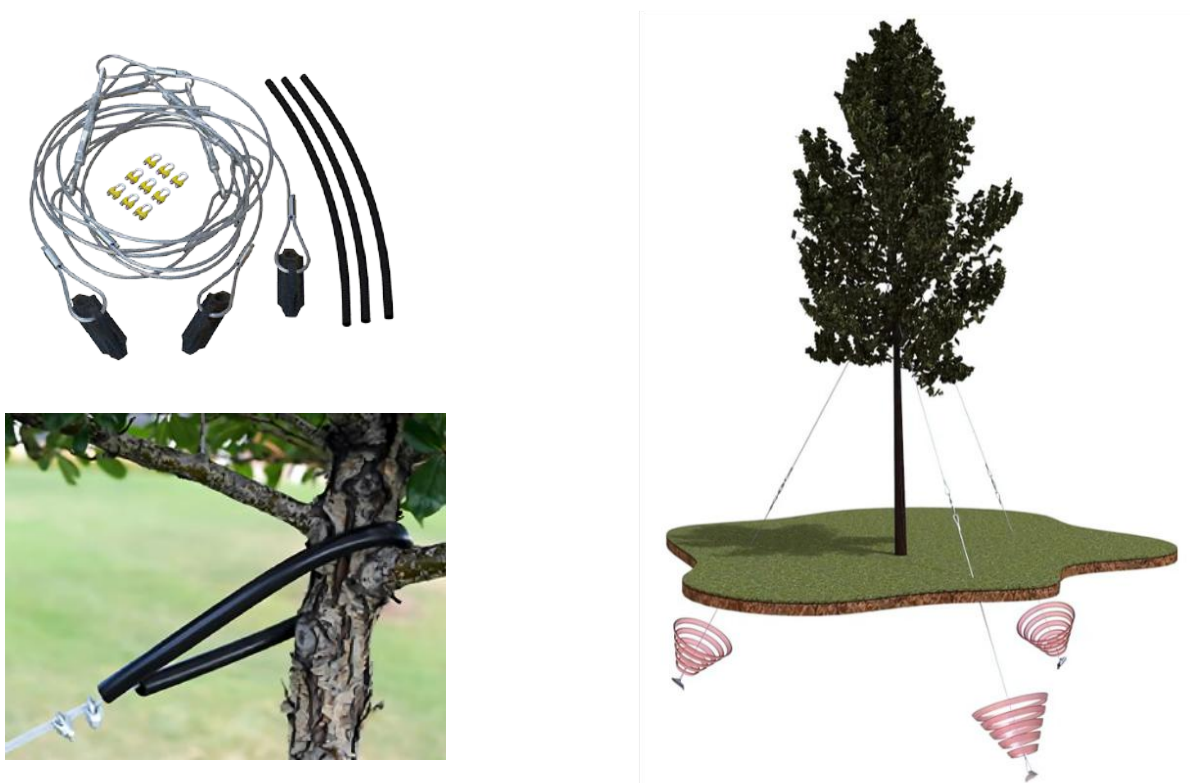

EARTH ANCHOR PALM TREE KIT

Similar to the Tree Guying Kit, the Palm Tree Anchoring Kit also includes guy anchor assemblies with HULK Earth Anchors, wire rope, and turnbuckles. The HULK Earth Anchor is driven and set into undisturbed soil. As palm trees do not have suitable branches to attach the guy-lines to, the included Palm Tree Collar is secured to the trunk of the palm with the integrated ratchet tensioner. Once attached to the palm tree, the anchored guy-lines are secured to the attachment tabs of the palm tree collar with the wire rope grips. The turnbuckles can be adjusted to fine tune the installation and securely anchor the tree.

HULK EARTH ANCHOR UNDERGROUND TREE KITS				
Kit Model	Kit Contents	Anchor MBL	Max. Tree Index AS2303:2015	Max. Planter Size (L)
HP25PGK	3qty HULK HP25 Earth Anchors with fitted guy lines of 3mm x 4.5m wire rope. 6qty 3mm wire rope grips. 1qty Palm Tree Collar.	6.85KN	224	250
HP35PGK	3qty HULK HP35 Earth Anchors with fitted guy lines of 4mm x 5.5m wire rope with turnbuckle. 6qty 4mm wire rope grips. 1qty Palm Tree Collar.	11.2KN	1125	1000
H50PGK*	3qty HULK H50 Earth Anchors with fitted guy lines of 6mm x 6.5m wire rope with turnbuckle. 9qty 6mm wire rope grips. 1qty Palm Tree Collar.	25.4KN	2393	2500
H80PGK*	3qty HULK H80 Earth Anchors with fitted guy lines of 6mm x 6.5m wire rope with turnbuckle. 9qty 6mm wire rope grips. 1qty Palm Tree Collar.	25.4KN	2393	2500
H110PGK*	3qty HULK H110 Earth Anchors with fitted guy lines of 6mm x 6.5m wire rope with turnbuckle. 9qty 6mm wire rope grips. 1qty Palm Tree Collar.	25.4KN	2393	2500

*Note: These kits have the same MBL, different anchor sizes cater for hard, medium and soft soils.
 To order a kit in a 4 leg variant, add "4" to the above Kit Model Code.
 E.g. HP35PGK4 For the 4 Leg Variant

Kit capacity is soil dependant. One kit anchors one tree. HULK Smasher drive rod sold separately. Installation instructions included.





HULK UNDERGROUND TREE ANCHOR KITS

HULK Underground Tree Kits provide a secure below-ground anchoring solution that supports newly planted trees by stabilising the rootball. This promotes strong root establishment and encourages upright, healthy tree growth. HULK Earth Anchors are ideal for sites where guying systems or visible stakes are not suitable or desirable, offering a clean and reliable alternative. These kits are perfect for use in parks, playgrounds, footpaths, walkways, and other public spaces where safety and aesthetics are essential.

Supplied as ready-to-use kits, HULK Underground Tree Kits offer:

- Fast and simple installation
- A wide range of kits to suit various applications and tree sizes
- No visible guy lines or stakes
- No trip hazards near planted trees
- Reduced risk of theft or vandalism

HULK Underground Tree Kits are available in three anchoring types: Earth Anchors, Concrete Anchors, and Deadman Anchors. This versatile range allows for tree anchoring in a wide variety of settings – from urban rooftop gardens to expansive parklands and rural environments, and everything in between.



EARTH ANCHOR KITS

The HULK Earth Anchor Underground Tree Kit's core component is the HULK Percussion Driven Earth Anchor. HULK Earth Anchors are installed by driving the anchor into undisturbed soil with a suitable hammer, and a re-usable HULK Smasher Rod. After the anchor is installed to the required depth, the reusable HULK Smasher Rod is easily removed. An upward pull on the anchor tendon sets the anchor in place, and is ready for use immediately. The HULK Earth Anchors are installed at the bottom of the planting hole, evenly spaced around the tree's rootball. The rootball tensioning strap with ratchet secures the tree to the anchors and brings the system into tension.

HULK EARTH ANCHOR UNDERGROUND TREE KITS					
Kit Model	Anchor Type	Tension Straps	Lashing Capacity	Max. Tree Index AS2303:2015	Max. Planter Size (L)
HP25UTK	3qty HP25 Anchors with Fitted D-Rings	3qty H110 Anchors with fitted D-Rings	250KG	224	250
HP35UTK	3qty HP35 Anchors with fitted D-Rings	3qty H110 Anchors with fitted D-Rings	400KG	1125	1000
H50UTK*	3qty H50 Anchors with fitted D-Rings	1qty 6.5m Red tensioning strap with ratchet	1250KG	2393	2500
H50UTK*	3qty H80 Anchors with fitted D-Rings	1qty 6.5m Red tensioning strap with ratchet	1250KG	2393	2500
H110UTK*	3qty H110 Anchors with fitted D-Rings	1qty 6.5m Red tensioning strap with ratchet	1250KG	2393	2500

*Note: These kits have the same Lashing Capacity, different anchor sizes cater for hard, medium and soft soils.
 To order a kit with Rootball Protecting Mats add "M" to the above Kit Model Code.
 To order a kit in a 4 leg variant, add "4" to the above Kit Model Code.
 E.g. HP35UTKM4 includes Protection Mats in the 4 Leg Variant.

Kit capacity is soil dependant. One kit anchors one tree. HULK Smasher drive rod sold separately. Installation instructions included.





DEADMAN ANCHOR KITS

The HULK Deadman Tree Anchor Kit is a below ground tree anchoring system for use where it is not possible to install percussion driven earth anchors. Typically used on difficult sites where services or underground utilities may be present, or where ground conditions do not allow for HULK Earth Anchor installation. The included HULK Deadman Anchor Slings are attached to the deadman anchors placed at the bottom of the planting hole. Well compacted soil is placed over the anchors to provide added stability. The rootball tensioning strap secures the tree in place with the integrated ratchet tensioner.

HULK EARTH ANCHOR UNDERGROUND TREE KITS					
Kit Model	Anchor Type	Tension Straps	Lashing Capacity	Max. Tree Index AS2303:2015	Max. Planter Size (L)
DMK3UTK	3qty 3mm Deadman Slings with fitted D-Rings	1 qty 2.5m Green tensioning strap with ratchet	250KG	330	400
DMK4UTK	3qty 3mm Deadman Slings with fitted D-Rings	1 qty 5.5 Blue tensioning strap with ratchet	400KG	849	800
DMK6UTK	3qty 3mm Deadman Slings with fitted D-Rings	1 qty 6.5m Red tensioning strap with ratchet	1250KG	1343	2000

To order a kit with Rootball Protecting Mats add "M" to the above Kit Model Code.
 To order a kit in a 4 leg variant, add "4" to the above Kit Model Code.
 E.g. DMK3UTKM4 includes Protection Mats in the 4 Leg Variant.

Each kit anchors one tree. Installation instructions included.





CONCRETE ANCHOR KITS

HULK Concrete Anchor Tree Kits are ideal for anchoring trees in planting containers, or where concrete flooring is below the planting location. Typically installed in metropolitan environments, such as rooftop gardens, indoor plantings, and street sidewalks. The supplied mechanical concrete anchors can be installed into the container side wall, or a concrete base below to provide an effective anchoring solution. The rootball tensioning strap, with integrated ratchet, brings the system into tension effectively securing the tree in place.

HULK EARTH ANCHOR UNDERGROUND TREE KITS					
Kit Model	Anchor Type	Tension Straps	Lashing Capacity	Max. Tree Index AS2303:2015	Max. Planter Size (L)
EB8UTK	3qty M8 Mechanical Anchors with Fitted D-Rings	1qty 4.5m Green tensioning strap with ratchet	250KG	224	250
EB10UTK	3qty M10 Mechanical Anchors with fitted D-Rings	1qty 7.5m Blue tensioning strap with ratchet	400KG	1125	1000
EB12UTK	3qty M12 Mechanical Anchors with fitted D-Rings	1qty 8.5m Red tensioning strap with ratchet	1250KG	2393	2500

To order a kit with Rootball Protecting Mats add "M" to the above Kit Model Code.
 To order a kit in a 4 leg variant, add "4" to the above Kit Model Code.
 E.g. EB10UTKM4 includes Protection Mats in the 4 Leg Variant.

Each kit anchors one tree. Installation instructions included.





SECTION 2

LANDSCAPE
EDGING

FORMLINE® FLEXIBLE RANGE LANDSCAPE EDGING

For effortlessly creating smooth flowing curves and circles

For those looking to elevate their garden or outdoor space with premium edging solutions, Formline® Landscape Edging offers the perfect blend of durability and style. Discover a wide range of in-ground and above-ground options. Whether you're a professional landscaper seeking high-quality edging materials or a garden enthusiast aiming to add elegance and definition to your borders, Formline® Landscape Edging delivers innovative and practical solutions built to last—ensuring your investment stands the test of time.

The collection features various options in Weathering and Galvanized Steel, allowing you to choose the finish that best suits your aesthetic. These products can transform outdoor areas into visually striking and well-organized spaces while offering exceptional durability and a refined appearance. Explore Formline® Landscape Edging's range today and take the first step towards creating the beautiful outdoor sanctuary you've always imagined.



PRODUCT CODE

FW07501K (Weathering Steel)
FG07501K (Galvanized Steel)

Included:
Flexible Edging Length with Joiner
(2200mm long)

3 Twisted Nails (300mm long)

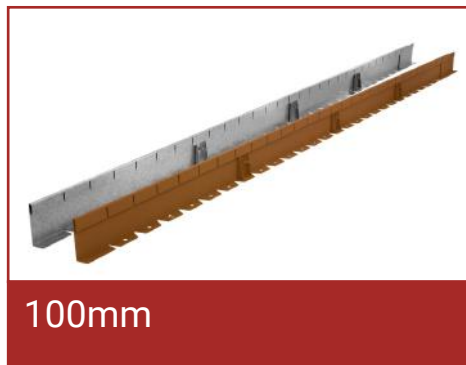

PRODUCT CODE

FW10001K (Weathering Steel)
FG10001K (Galvanized Steel)

Included:
Flexible Edging Length with Joiner
(2200mm long)

3 Braces
3 Twisted Nails (300mm long)



PRODUCT CODE

FW15001K (Weathering Steel)
FG15001K (Galvanized Steel)
FG15001K-B (Powdercoated Black)
FG15001K-CH (Powdercoated Charcoal)

Included:
Flexible Edging Length with Joiner
(2200mm long)

3 Braces
3 Twisted Nails (300mm long)

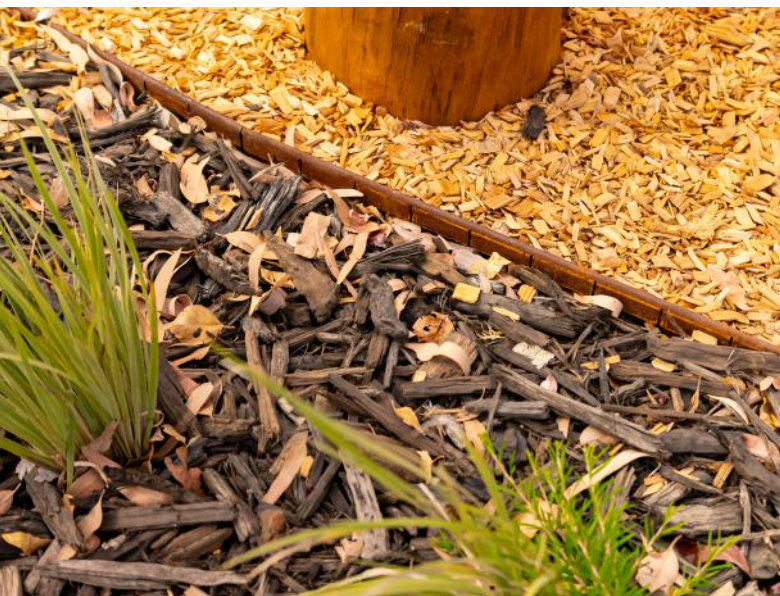



185mm

PRODUCT CODE

- FW18501K** (Weathering Steel)
- FG18501K** (Galvanized Steel)

Included:
Flexible Edging Length with Joiner
(2200mm long)

- 3 Braces
- 3 Twisted Nails (300mm long)

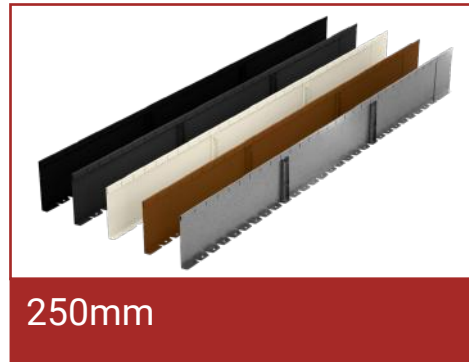

250mm

PRODUCT CODE

- FW25001K** (Weathering Steel)
- FG25001K** (Galvanized Steel)
- FG25001K-B** (Powdercoated Black)
- FG25001K-CH** (Powdercoated Charcoal)
- FG25001K-WH** (Powdercoated White)

Included:
Flexible Edging Length with Joiner
(2200mm long)

- 2 Braces
- 5 Twisted Nails (300mm long)



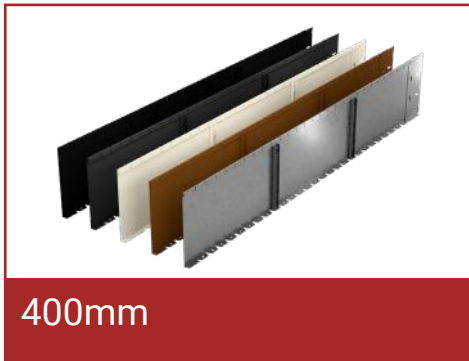

400mm

PRODUCT CODE

- FW40001K** (Weathering Steel)
- FG40001K** (Galvanized Steel)
- FG40001K-B** (Powdercoated Black)
- FG40001K-CH** (Powdercoated Charcoal)
- FG40001K-WH** (Powdercoated White)

Included:
Flexible Edging Length with Joiner
(2200mm long)

2 Braces
5 Twisted Nails (300mm long)

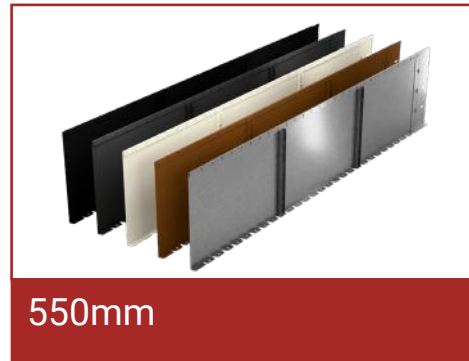

550mm

PRODUCT CODE

- FW55001K** (Weathering Steel)
- FG55001K** (Galvanized Steel)
- FG55001K-B** (Powdercoated Black)
- FG55001K-CH** (Powdercoated Charcoal)
- FG55001K-WH** (Powdercoated White)

Included:
Flexible Edging Length with Joiner
(2200mm long)

2 Braces
5 Twisted Nails (300mm long)

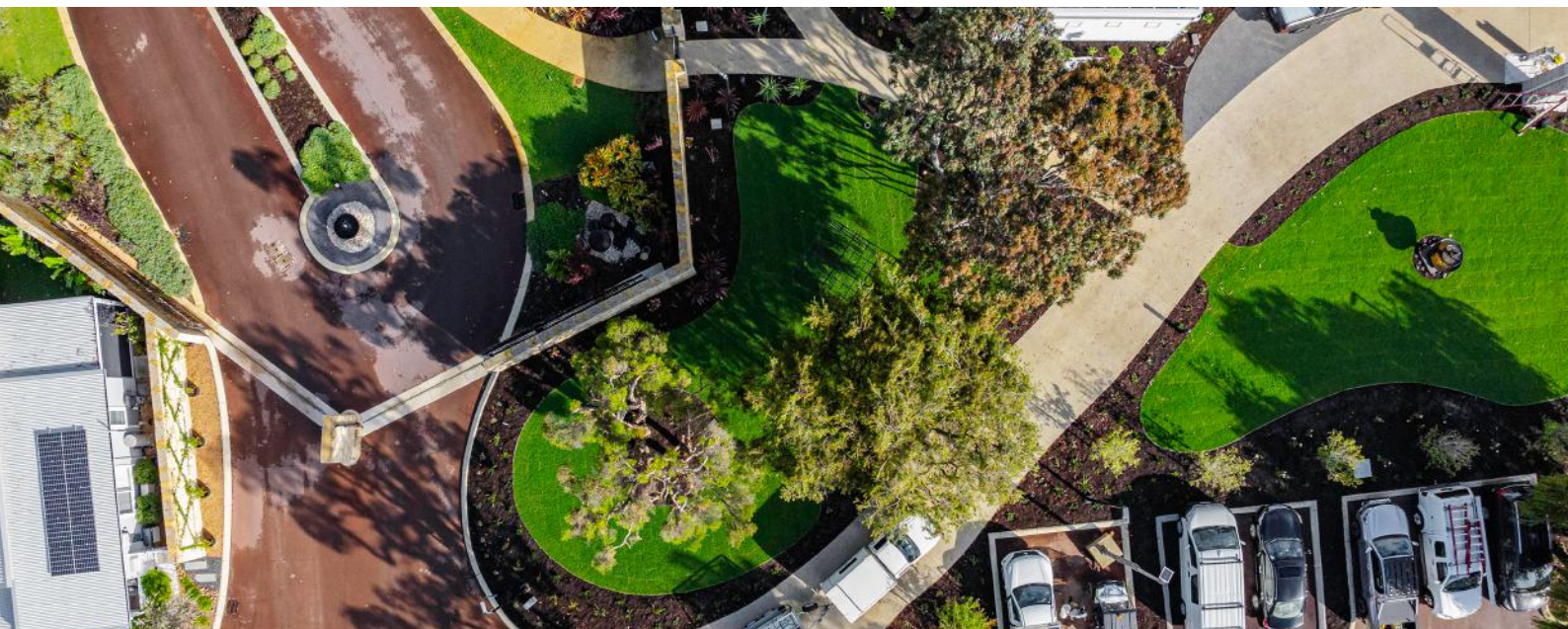



FORMLINE® RIGID RANGE LANDSCAPE EDGING

For effortlessly creating firm straight lines and shapes

Enhance your landscape with Formline® Rigid Landscape Edging. Precision-engineered from durable weathered or galvanised steel, this edging offers quick and easy installation with a pre-attached connector plate. Ideal for edging garden beds, lawns, and stone features, each length includes three fixing nails for added support.



75mm

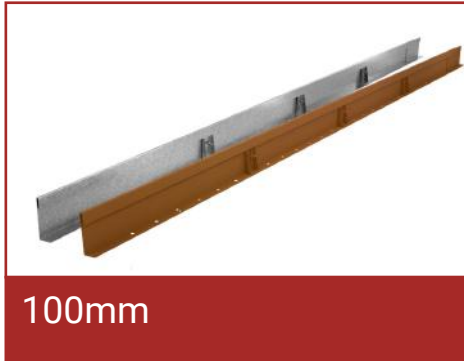

100mm

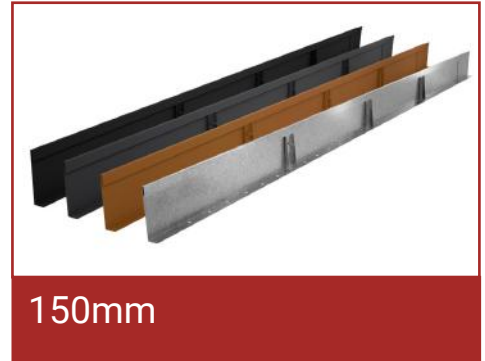

150mm

PRODUCT CODE

- RW07501K** (Weathering Steel)
- RG07501K** (Galvanized Steel)

Included:
Rigid Edging Length with Joiner
(2200mm long)

3 Twisted Nails (300mm long)

PRODUCT CODE

- RW10001K** (Weathering Steel)
- RG10001K** (Galvanized Steel)

Included:
Rigid Edging Length with Joiner
(2200mm long)

3 Braces
3 Twisted Nails (300mm long)

PRODUCT CODE

- RW15001K** (Weathering Steel)
- RG15001K** (Galvanized Steel)
- RG15001K-B** (Powdercoated Black)
- RG15001K-CH** (Powdercoated Charcoal)

Included:
Rigid Edging Length with Joiner
(2200mm long)

3 Braces
3 Twisted Nails (300mm long)

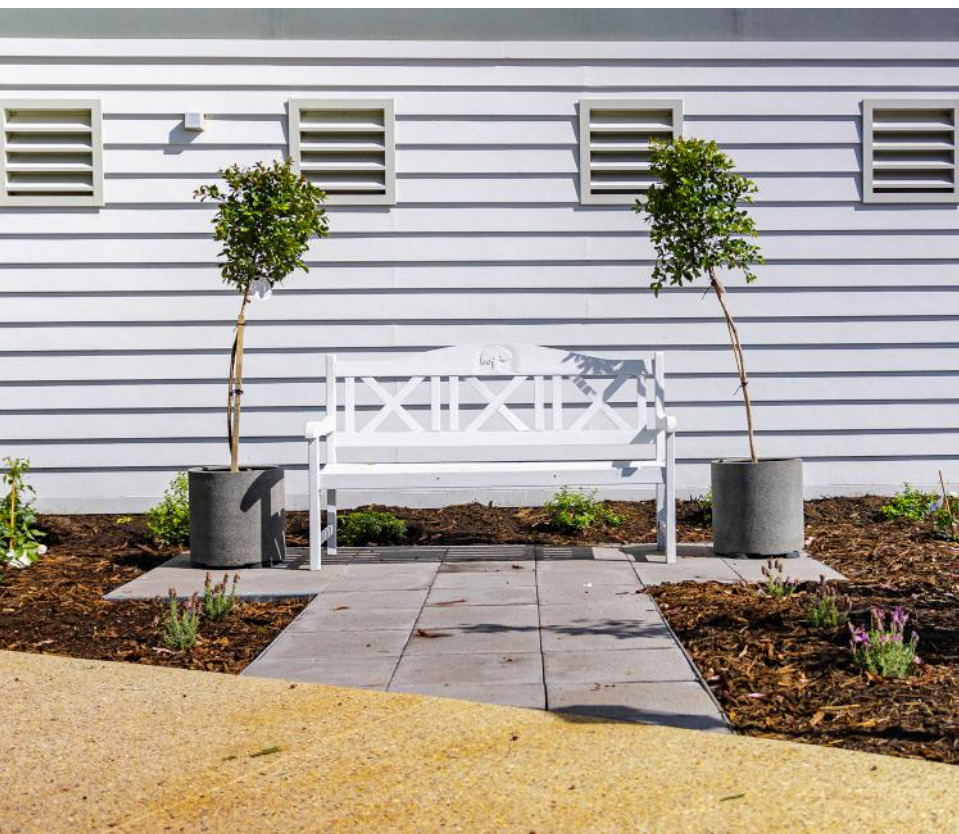



185mm

PRODUCT CODE

- RW18501K** (Weathering Steel)
- RG18501K** (Galvanized Steel)

Included:
Rigid Edging Length with Joiner
(2200mm long)

2 Braces
5 Twisted Nails (300mm long)

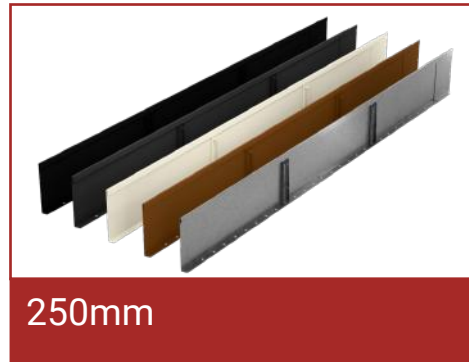

250mm

PRODUCT CODE

- RW25001K** (Weathering Steel)
- RG25001K** (Galvanized Steel)
- RG25001K-B** (Powdercoated Black)
- RG25001K-CH** (Powdercoated Charcoal)
- RG25001K-WH** (Powdercoated White)

Included:
Rigid Edging Length with Joiner
(2200mm long)

2 Braces
5 Twisted Nails (300mm long)



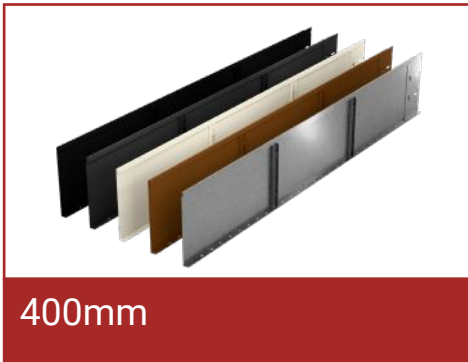

400mm

PRODUCT CODE

- RW40001K** (Weathering Steel)
- RG40001K** (Galvanized Steel)
- RG40001K-B** (Powdercoated Black)
- RG40001K-CH** (Powdercoated Charcoal)
- RG40001K-WH** (Powdercoated White)

Included:
Rigid Edging Length with Joiner
(2200mm long)

2 Braces
5 Twisted Nails (300mm long)

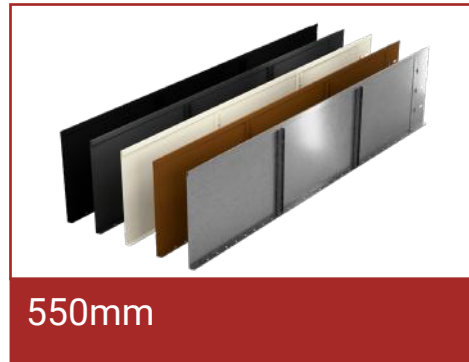

550mm

PRODUCT CODE

- RW55001K** (Weathering Steel)
- RG55001K** (Galvanized Steel)
- RG55001K-B** (Powdercoated Black)
- RG55001K-CH** (Powdercoated Charcoal)
- RG55001K-WH** (Powdercoated White)

Included:
Rigid Edging Length with Joiner
(2200mm long)

2 Braces
5 Twisted Nails (300mm long)



FORMLINE® CIRCULAR PLANTERS

For effortlessly creating smooth, balanced circles and graceful curves

For those looking to enhance their outdoor spaces with refined, statement-making elements, Formline® Circular Planters offer a seamless blend of strength, simplicity, and contemporary design. Crafted for both residential and commercial landscapes, these premium architectural planters provide an elegant solution for showcasing trees, shrubs, and feature plantings while bringing structure and visual impact to any environment.

Manufactured from 2mm weathering (Corten) steel, the planters are built for long-term durability and naturally develop a rich, warm patina over time—perfectly complementing modern, industrial, and rustic settings alike. With a generous 600mm height, they allow ample soil volume for healthy root development without compromising on a clean, minimalist aesthetic. Precision-rolled and supplied in three easy-to-assemble segments, Formline® Circular Planters deliver a professional finish ideal for gardens, streetscapes, and large-scale commercial projects.



PRODUCT CODE

CPW250600 (Weathering Steel)

Included:
Circular Planter 250mm High x
600mm Diameter



PRODUCT CODE

CPW250900 (Weathering Steel)

Included:
Circular Planter 250mm High x
900mm Diameter



PRODUCT CODE

CPW2501200 (Weathering Steel)

Included:
Circular Planter 250mm High x
1200mm Diameter





400 x 600mm

PRODUCT CODE

CPW400600 (Weathering Steel)

Included:
Circular Planter 400mm High x
600mm Diameter



400 x 900mm

PRODUCT CODE

CPW400900 (Weathering Steel)

Included:
Circular Planter 400mm High x
900mm Diameter



400 x 1200mm

PRODUCT CODE

CPW4001200 (Weathering Steel)

Included:
Circular Planter 400mm High x
1200mm Diameter





PRODUCT CODE

CPW600600 (Weathering Steel)

Included:
Circular Planter 600mm High x
600mm Diameter



PRODUCT CODE

CPW600900 (Weathering Steel)

Included:
Circular Planter 4600mm High x
900mm Diameter



PRODUCT CODE

CPW6001200 (Weathering Steel)

Included:
Circular Planter 6000mm High x
1200mm Diameter





FORMLINE® TREE RINGS

For perfectly framing and protecting trees with clean, professional circles

For those seeking a refined and practical solution to neatly frame trees, garden beds, and feature plantings, Formline® Tree Rings deliver a durable, professional finish with timeless appeal. Designed to suit both residential gardens and large-scale commercial landscapes, these pre-formed steel rings provide structure and definition while helping to prevent soil movement and lawn encroachment.



150 x 600mm

PRODUCT CODE

- CPW150600** (Weathering Steel)
- CPG150600** (Galvanized Steel)

Included:
Tree Ring 150mm High x 600mm Diameter



150 x 900mm

PRODUCT CODE

- CPW150600** (Weathering Steel)
- CPG150600** (Galvanized Steel)

Included:
Tree Ring 150mm High x 900mm Diameter



150 x 1200mm

PRODUCT CODE

- CPW1501200** (Weathering Steel)
- CPG1501200** (Galvanized Steel)

Included:
Tree Ring 150mm High x 1200mm Diameter





LINKEDGE™ COMMERCIAL GRADE ALUMINUM EDGING

Cement will crack, can be tricky to lay and is also time consuming. Plastic will break down and become brittle in the sun. LinkEdge is time and economically efficient with the usability and strength of steel, yet it will not rust or leave sharp edges. It is completely flexible and can form curves, circles and straight lines with ease. Also available in range of powder-coated colours. Never before has an edge offered this much.

Heights available are:

40mm, 50mm, 75mm and 100mm. Sold in 3 metre lengths. 150mm and 300mm long spiral spikes are available for fixing the edge.

LINKEDGE™ RANGE

STANDARD RANGE

PRODUCT CODE

EDG0403AL	LinkEdge - 40mm x 3m
EDG0503AL	LinkEdge - 50mm x 3m
EDG0753AL	LinkEdge - 75mm x 3m
EDG1003AL	LinkEdge - 100mm x 3m



PRODUCT CODE

LERAJ4050	LinkEdge - Right Angle Joiner for 40 & 50mm
LERAJ75100	LinkEdge - Right Angle Joiner for 75 & 100mm

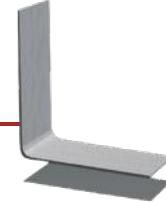

PRODUCT CODE

FPC4050AL	LinkEdge - Fishplate for 40 & 50mm
FPC75100AL	LinkEdge - Fishplate for 75 & 100mm

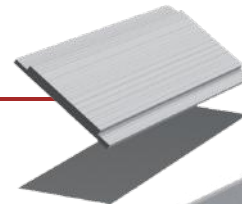

HEAVY DUTY RANGE

PRODUCT CODE

HDEDG0503AL	LinkEdge, 50mm x 3m
HDEDG0753AL	LinkEdge, 75mm x 3m
HDEDG1003AL	LinkEdge, 100mm x 3m



PRODUCT CODE

SPG075100AL	LinkEdge - Spike Guides for 75mm & 100mm
--------------------	--

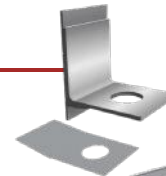

PRODUCT CODE

ESQ07550	LinkEdge - 50cm Square
ESQ075100	LinkEdge - 100cm Square

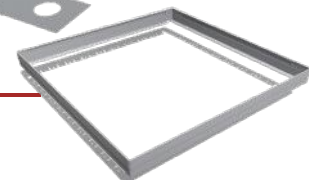

PRODUCT CODE

ECL10063	LinkEdge 63cm Circle
ECL10095	LinkEdge 95cm Circle



PRODUCT CODE

SPI150AL	LinkEdge - Spike 150mm
SPI300AL	LinkEdge - Spike 300mm





EDGEMAXX™ PLASTIC LANDSCAPE EDGE

EDGEMAXX™ Plastic Landscape Edge is a durable and versatile edging solution designed to define and separate lawns, garden beds, and other landscaped areas with ease. Made from heavy-duty plastic, it offers long-lasting performance and flexibility, making it ideal for both residential and commercial applications. Available in a choice of black, green, or terracotta to suit a range of landscape designs, EDGEMAXX™ comes in heights of 75mm, 100mm, and 150mm, and is sold in convenient 30-metre rolls. For secure installation, compatible plastic spikes are available to keep the edging firmly in place.

Product Code	Description	Colour	Size
EMB7530	EdgeMaxx Garden Edging	Black	75mm x 30m
EMG7530	EdgeMaxx Garden Edging	Green	75mm x 30m
EMT7530	EdgeMaxx Garden Edging	TerraCotta	75mm x 30m
EMB10030	EdgeMaxx Garden Edging	Black	100mm x 30m
EMG10030	EdgeMaxx Garden Edging	Green	100mm x 30m
EMT10030	EdgeMaxx Garden Edging	TerraCotta	100mm x 30m
EMB15030	EdgeMaxx Garden Edging	Black	150mm x 30m
EMG15030	EdgeMaxx Garden Edging	Green	150mm x 30m
EMT15030	EdgeMaxx Garden Edging	TerraCotta	150mm x 30m
EMPB50	EdgeMaxx Edging Pegs	Black	50/pack
EMPG50	EdgeMaxx Edging Pegs	Green	50/pack
EMPT50	EdgeMaxx Edging Pegs	TerraCotta	50/pack



RHINOWELD

GABION STRUCTURES

Beauty, Strength
and Style



“

Simple and effective.
The gabions really
compliment the design.

”



SECTION 3

GABIONS

RHINOWELD WELDED MESH GABIONS

RhinoWeld Welded Mesh Gabions are ideal for architectural applications such as letterboxes, garden seats, flower pots, retaining structures, feature wall claddings, sound walls, landscape features, and many other uses that combine the beauty of natural rock with the strength of a steel cage. You are only limited by your imagination!

All wire conforms to international standards for tensile strength and tolerances and is manufactured under ISO 9001 accreditation. The wire is coated with a heavy Galfan layer that meets international standards for both consistency and quality, offering superior protection.

Whether you're using them for erosion control, earth retention, soil stabilisation, flood control, or as an eye-catching feature wall, RhinoWeld Gabions are a versatile, high-calibre solution. The Galfan coating extends corrosion resistance far beyond that of traditional galvanised steel, even in harsh weather and saline conditions.

To make your purchase easier, RhinoWeld Gabion Kits are available and include all the necessary accessories to construct a RhinoWeld basket quickly and efficiently—no time wasted calculating the number of mesh panels or spirals required; we've done the work for you!

Additionally, if you're planning to join multiple structures together, we've made it more economical by offering a purpose-designed 'add-on' kit. This includes the panels and accessories needed to connect gabions without the extra cost and waste of purchasing multiple full kits.

1 x 0.3 x 0.5m

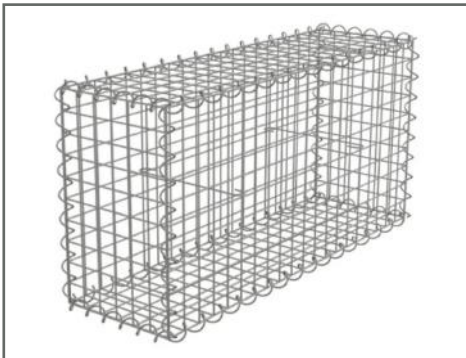

Full Kit

PRODUCT CODE

RWK50410305 - 50mm x 50mm
RWK75410305 - 75mm x 75mm

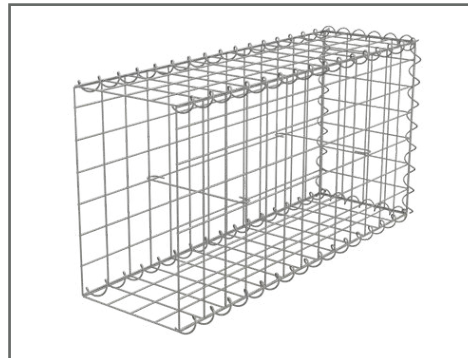

Add-on Kit

PRODUCT CODE

RWA50410305 - 50mm x 50mm
RWA75410305 - 75mm x 75mm





0.5 x 0.5 x 0.5m

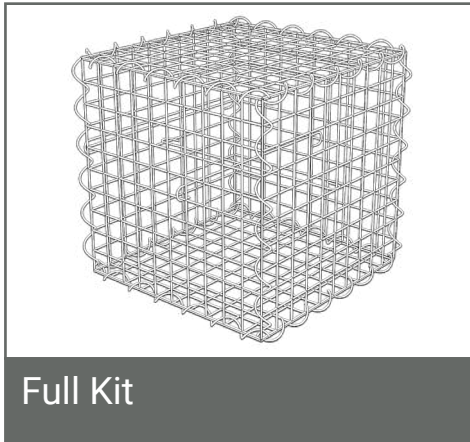

Full Kit

PRODUCT CODE

- RWK5040505** - 50mm x 50mm
- RWK7540505** - 75mm x 75mm



Add-on Kit

PRODUCT CODE

- RWA5040505** - 50mm x 50mm
- RWA7540505** - 75mm x 75mm

0.5 x 0.5 x 1m

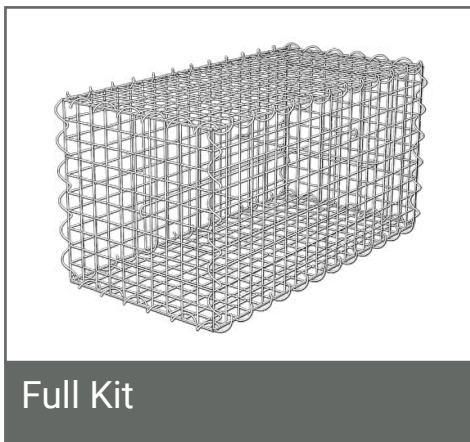

Full Kit

PRODUCT CODE

- RWK5040510** - 50mm x 50mm
- RWK7540510** - 75mm x 75mm



Add-on Kit

PRODUCT CODE

- RWA5040510** - 50mm x 50mm
- RWA7540510** - 75mm x 75mm

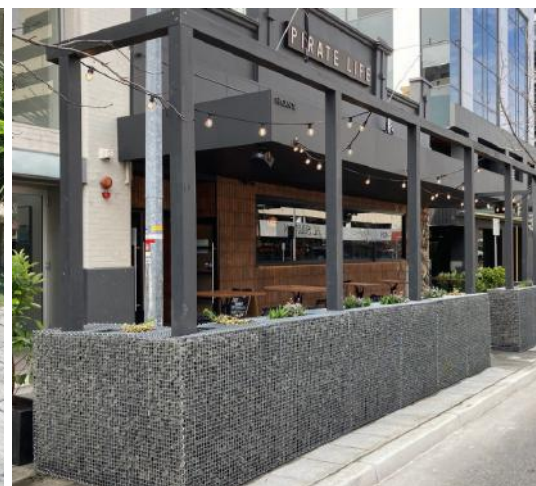

0.5 x 0.5 x 2m

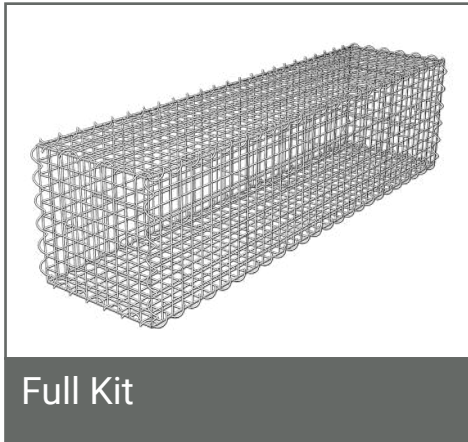

Full Kit

PRODUCT CODE

RWK5040520 - 50mm x 50mm
RWK7540520 - 75mm x 75mm

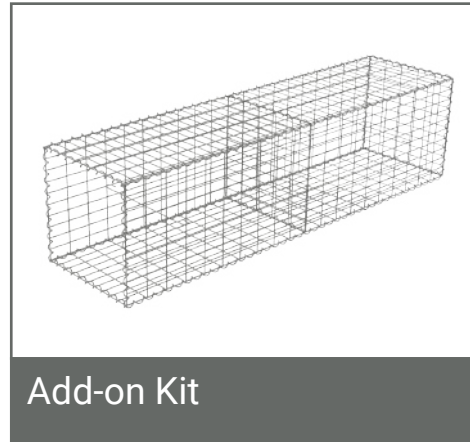

Add-on Kit

PRODUCT CODE

RWA5040520 - 50mm x 50mm
RWA7540520 - 75mm x 75mm

0.5 x 0.5 x 1m



Full Kit

PRODUCT CODE

RWK5041051 - 50mm x 50mm
RWK7541051 - 75mm x 75mm



Add-on Kit

PRODUCT CODE

RWA5041051 - 50mm x 50mm
RWA7541051 - 75mm x 75mm

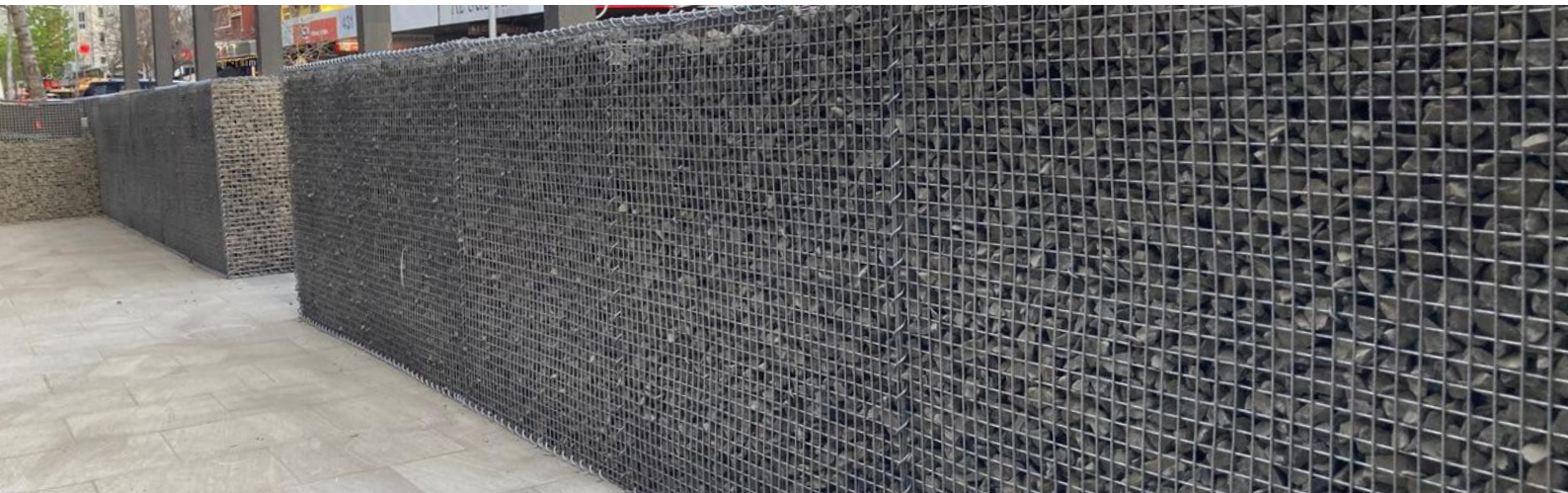



1 x 1 x 1m



PRODUCT CODE

RWK504111 - 50mm x 50mm

RWK754111 - 75mm x 75mm



PRODUCT CODE

RWA504111 - 50mm x 50mm

RWA754111 - 75mm x 75mm



RHINOWELD PANELS

These units consist of various elements such as end panels, base panels, top panels, side panels, bracing wires, and spirals or 'C' clips. Each component can be purchased separately, allowing for customisation based on the shape and size of your structure. Whether it's for landscaping, erosion control, or creative design, RhinoWeld Gabion mesh can be tailored to meet the unique requirements of your project. Explore the possibilities and create stunning structures with RhinoWeld Gabions from StrataGreen.

MESH SIZE: 25 X 25MM

Product Code	Panel Sizes (m)
RW2530305	0.3 x 0.5m
RW2530310	0.3 x 1m
RW2530505	0.5 x 0.5m
RW2530510	0.5 x 1m
RW2531010	1 x 1m
RW2532005	2 X 0.5M
RW2532010	2 x 1m

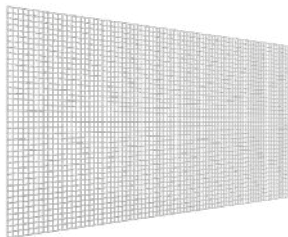

MESH SIZE: 50 X 50MM

Product Code	Panel Sizes (m)
RW5040305	0.3 x 0.5m
RW5040310	0.3 x 1m
RW5040320	0.3 x 2m
RW5040505	0.5 x 0.5m
RW5040510	0.5 x 1m
RW5041010	1 X 1M
RW5042005	2 x 0.5m
RW5042010	2 x 1m

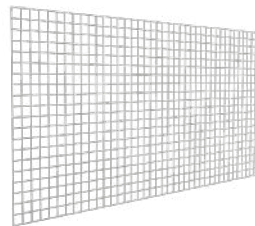

MESH SIZE: 75 X 75MM

Product Code	Panel Sizes (m)
RW7540305	0.3 x 0.525m
RW7540310	0.3 x .975m
RW7540320	0.3 x 2.025m
RW7540505	0.525 x 0.525m
RW7540510	0.525 x 0.975m
RW7541010	0.975 X 0.975M
RW7542005	2.025 x 0.525m
RW7542010	2.025 x 0.975m

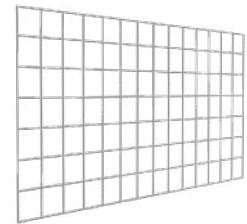

MESH SIZE: 100 X 50MM

Product Code	Panel Sizes (m)
RW1040305	0.3 x 0.5m
RW1040310	0.3 x 1m
RW1040503	0.5 x 0.3m
RW1040505	0.5 x 0.5m
RW1040510	0.5 x 1m
RW1041003	1 X 0.3M
RW1041005	1 x 0.5m
RW1041010	1 x 1m
RW1042003	2 x 0.3m
RW1042005	2 x 0.5m
RW1042010	2 x 1m

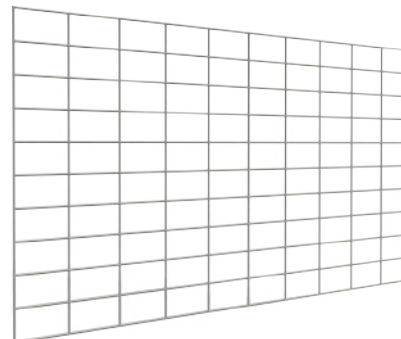



RHINOWELD ACCESSORIES

BRACEHOOKS

Bracehooks are essential components used to provide internal support and maintain the structural integrity of RhinoWeld Weldmesh Gabions during the filling process. They help prevent bulging and ensure the gabion retains its intended shape, offering long-lasting stability and performance.

Product Code	Length	
RWB030	316mm	Each brace hook is inserted as filling proceeds
RWB050	516mm	
RWB054	540mm	
RWB099	990mm	
RWB100	1m	

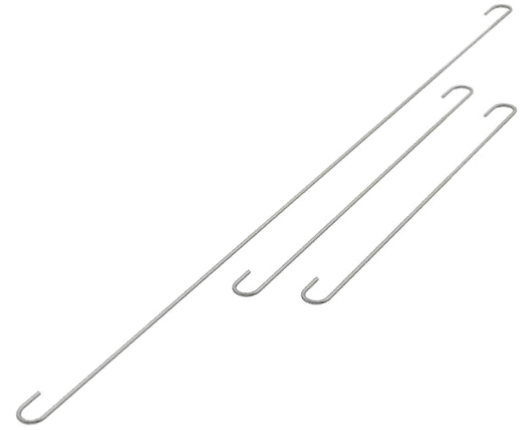

SPIRALS

Spiral lacing wires are the standard method for securely connecting RhinoWeld Weldmesh panels. Engineered with a 50mm pitch for reliable interlocking, these spirals are available in 0.3m, 0.5m, or 1m lengths to suit your project requirements. Some minor on-site cutting may be required for custom fits, ensuring flexibility and ease of installation.

Product Code	Length
RWS030	300mm
RWS050	500mm
RWS052	525mm
RWS097	975mm
RWS100	1m

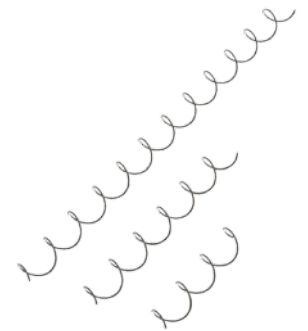

C-CLIPS

C-Clips provide a quick and mechanical fastening solution for RhinoWeld Gabions when used with a lacing gun. Available in both Stainless Steel and Galvan finish, these clips deliver strong and secure connections, ideal for applications requiring enhanced durability and corrosion resistance.

Product Code	Material	Units
RWCG	Galvan	1,600/box
RWCS	Stainless Steel	1,600/box



LACING GUN

The pneumatic lacing gun is designed for effortless and efficient installation of C-Clips on RhinoWeld Gabion structures. By securely closing clips with precision, it enhances the strength and stability of the gabion assembly. Lacing guns are also available for hire to customers in Western Australia and New South Wales.

Product Code	Size	Air Pressure (MPa)
RWLG	500mm x 330mm x 220mm	0.6 - 0.7 (87 - 101psi)



Did you know you can order online at StrataGreen?

Learn more

Sign up for a Trade Account today.

Whether you're a contractor, landscaper, council, or nursery, a trade account



ORDER SMARTER, FASTER, EASIER – ALL ONLINE

Discover the easiest way to manage your ordering with our powerful online platform. Designed specifically with trade professionals in mind, our website offers a seamless experience that puts control at your fingertips – anytime, anywhere.

Here's what you can do online:

- ✔ **See Your Trade Pricing Instantly**
 - Log in with your trade account to view exclusive trade prices tailored to you.
- ✔ **Check Stock Availability**
 - Know what's in stock in real time, so you can plan with confidence.
- ✔ **Create Quotes On-the-Go**
 - Build project quotes directly from the website – perfect for client presentations and quick approvals.
- ✔ **Pay Invoices Securely Online**
 - Access your account history and settle invoices with just a few clicks, no phone calls or emails required.
- ✔ **View Past Orders and Reorder Fast**
 - Reordering is made easy with full order history and repeat purchase options.
- ✔ **Mobile-Friendly for On-Site Convenience**
 - Whether you're in the office or on-site, our website works smoothly on desktop, tablet and mobile.

ORDERING AT STRATAGREEN HAS NEVER BEEN EASIER

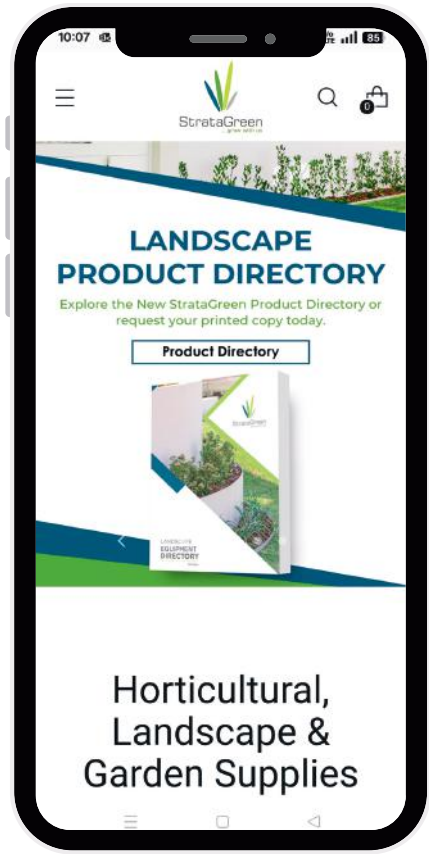



SECTION 4

EROSION
CONTROL



TERRAMAXX SILT FENCE

PRODUCT CODE

PSF860050

860mm H x 50m L

TerraMaxx Silt Fence is a temporary sediment control solution commonly used on construction sites to help protect water quality in nearby streams, rivers, lakes, and bays. Constructed from UV-stabilised green and black yarns, the fence is designed to resist degradation from sun exposure and environmental conditions. Available in 860mm high x 50m long rolls.



TERRAMAXX WINDBREAK

TerraMaxx Windbreak is a high-performance, UV-stabilised mesh designed to reduce wind velocity while maintaining essential airflow, making it ideal for protecting crops, seedlings, and outdoor growing environments. Unlike solid barriers that can cause turbulence and plant damage, this breathable mesh minimises wind impact without compromising ventilation. Durable and economical, TerraMaxx Windbreak is widely used in horticulture, agriculture, and landscaping applications—particularly around vegetable crops, orchards, nurseries, and fencelines—to reduce wind stress and promote healthier, more stable growth conditions.



PRODUCT CODE	SIZE	COLOUR
WB1050B	1.0m x 50m	Black
WB1050G	1.0m x 50m	Green
WB1850B	1.83m x 50m	Black
WB1850G	1.83m x 50m	Green

BIOTEK™ PINS

BioTek™ Pins are a safe, durable alternative to traditional steel U-pins, used to secure weedmat, jute or coir matting, soil saver, geotextiles, and turf. Made entirely from Polymaize—a fully biodegradable material derived from renewable resources like corn—these pins contain no crude oil-based plastics.

Over time, Polymaize naturally breaks down into water, carbon dioxide, and fertile humus, leaving no toxic or synthetic residue in the soil. Unlike steel pins, which corrode and pose injury risks as sharp, rusty spikes, BioTek™ Pins are safer for both people and animals.

They're available in two styles: a 175mm straight pin for hard soils, and a 280mm gripper pin designed for loose, sandy soils and steep slopes. The gripper design offers superior holding power—up to six times that of standard pins or stakes.



PRODUCT CODE	SIZE	PACKING
BP175	175mm Long	800 pins/carton
BGP280	280mm Long	400 pins/carton



GEOTEK™ GROUND STAPLES

GeoTek™ Ground Staples are used for securing weed mat, jute and coir matting, soil savers, geotextiles, and turf. Made from galvanised steel, they offer superior durability and rust protection. These U-shaped staples are available in a variety of lengths to suit different applications—for example, steeper slopes or softer soils require longer pins. Each staple features sharpened ends for easy ground penetration.

Product Code	Sizing	Units
WMGS200	200 x 35 x 4mm	200/box
WMGS300	300 x 50 x 4mm	200/box
WMGS3005	300 x 50 x 5mm	200/box
WMGS450	450 x 50 x 5mm	100/box
WMGS600	600 x 50 x 5mm	100/box

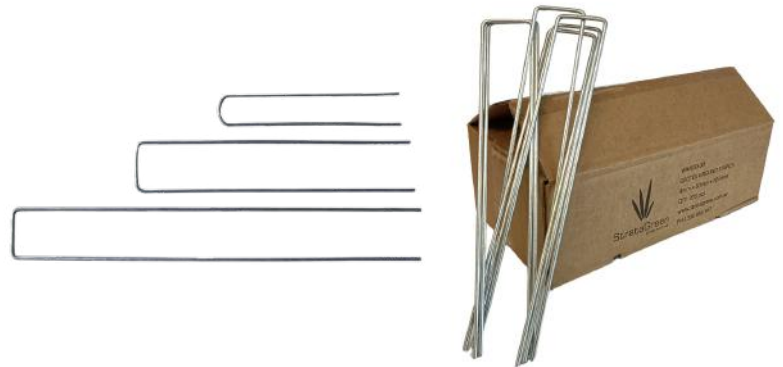

BIOTEK™ JUTE MATTING

BioTek™ Jute Matting is a 100% biodegradable and organic geotextile designed for soil stabilisation, weed suppression, erosion control, and moisture retention. It is reinforced with a 5oz hessian scrim to enhance durability and extend product life. Depending on site conditions, BioTek™ Jute Matting has a life expectancy of 18 months to 3 years. It is available in two grades: 500gsm and 800gsm.

Product Code	Roll Size	Weight Per Roll	Product Weight	Product Thickness	Life Expectancy
JM2025500	1.83m x 25m (45.75m ²)	± 23kg approx	500g/m ²	5mm	18 months
JM2025800	1.83m x 25m (45.75m ²)	± 36kg approx	800g/m ²	8mm	24-36 months
JM2025800PS 6 planting slits/sqm	1.83m x 25m (45.75m ²)	± 36kg approx	800g/m ²	8mm	24-36 months

BENEFITS

- BioTek™ Jute forms a mulch that suppresses weed growth and increases soil moisture retention, aiding in the establishment of long-term vegetation.
- BioTek™ Jute is 100% organic and biodegradable.
- An excellent method for stabilising slopes and channels while vegetation establishes.
- Easily fastened using steel or biodegradable pins.
- BioTek™ Jute promotes moisture retention, reducing water requirements and saving both time and money.
- Available pre-split for ease of planting (4 slits per square metre)
- BioTek™ Jute has hygroscopic properties—absorbing and attracting moisture from the air.

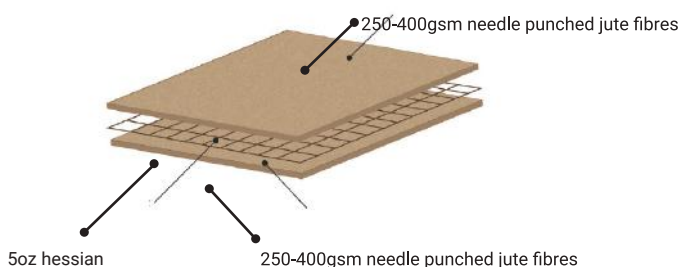



BIOTEK™ JUTE MESH SOIL SAVER

Product Code	Roll Size	Weight Per Roll	Product Weight	Mesh Size	Life Expectancy
JSS12550	1.2m x 550m (660m ²)	330kg approx	496g/m ²	20mm x 20mm	12 months

BioTek™ Jute Mesh Soil Saver is a 100% organic and biodegradable product made from jute. It is used for erosion control on slopes, dunes, and embankments. It is also effective for trapping seeds and supporting vegetation growth. BioTek™ Soil Saver is the most economical erosion control matting, making it highly suitable for large-scale projects.

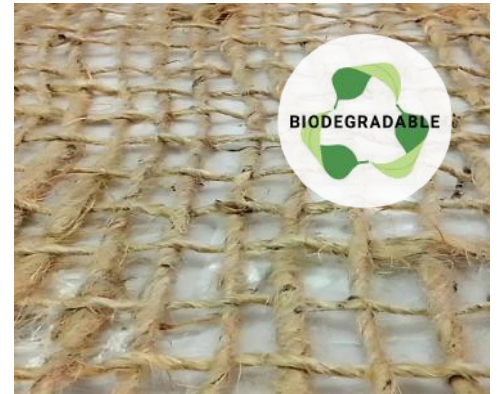

BIOTEK™ COIR MESH MATTING

BioTek™ Coir Mesh Matting is ideal for controlling soil erosion and improving soil conditions. Made from coir fibre, it is naturally resistant to rot and mould and is a more cost-effective alternative to synthetic geotextiles. The matting holds soil in place and prevents erosion by dissipating the force of heavy rain and water runoff. It provides long-lasting soil support, allowing natural vegetation to establish. BioTek™ Coir Mesh Matting also promotes plant growth by absorbing moisture and preventing the topsoil from drying out. Its strength and durability make it suitable for protecting slopes while encouraging vegetation to take root. Over time, the eco-friendly and biodegradable coir fully disintegrates, leaving behind only humus.

Product Code	Roll Size	Weight Per Roll	Product Weight	Mesh Size	Life Expectancy
H2M400	2m x 25m (50m ²)	20kg approx	400g/m ²	20mm x 20mm	12-18 months
H2M700	2m x 25m (50m ²)	35kg approx	700g/m ²	10mm x 10mm	24-36 months
H2M900	2m x 25m (50m ²)	45kg approx	900g/m ²	8mm x 8mm	24-36 months

BENEFITS

- BioTek™ Mesh Erosion Mattings are easy to plant or seed into – no slitting required
- BioTek™ Mesh Erosion Mattings can be seeded after they have been laid – unlike blanket-style mattings
- BioTek™ Mesh Erosion Mattings can be easily fastened with steel or biodegradable pins
- BioTek™ Mesh Erosion Mattings are 100% organic and biodegradable
- BioTek™ Mesh Erosion Mattings have superior drapeability





BIOTEK™ COIR LOGS

An environmentally friendly alternative to hay bales and costly riprap or cement stabilisation techniques, BioTek™ Coir Logs are ideal for constructing check structures, managing changes in stream flow velocity, shaping channels, and stabilising shorelines. They are also increasingly used to prevent scouring and soil loss on slopes and in gullies. The coir fibre filling absorbs and retains moisture to support tree and plant growth, while the tough, twisted rope outer sheath resists hydraulic forces from surface flows and helps trap sediment. BioTek™ Coir Logs are 100% biodegradable and last up to four years.

Product Code	Sizing	Weight
CL300	3m long x 300mm diameter	30kg
CL150	1.5m long x 300mm diameter	15kg
CL2030	3m long x 200mm diameter	20kg



BENEFITS

- Lightweight and easy to install
- Blends naturally into the environment over time
- Can be fixed in swales for sediment retention, and around wetlands and streambanks for wave mitigation
- Provides protection until natural vegetation is established
- Made from 100% biodegradable and renewable resources



BIOTEK™ COIR ROPE

PRODUCT CODE

CR850

Traditionally used to secure BioTek™ Coir Logs, BioTek™ Coir Rope is a versatile, biodegradable solution suitable for any application where a natural rope or tie is required. Made from twisted coir fibre, it comes in a convenient, easy-to-use 8mm x 50m roll.





MIRA-CELL CELLULAR CONFINEMENT SYSTEM

The Mira-Cell Cellular Confinement System is one of the most advanced technologies available for addressing complex soil stability challenges. It features an engineered, high-strength network of interconnected cells that confine and stabilise soil. The Mira-Cell system offers an innovative solution for applications such as slope and channel protection, load support, and earth retention.

Once installed, the system is backfilled with specific infill materials to create a durable and long-lasting stabilisation solution. A variety of infill options can be used, depending on the specific project requirements and site conditions.

Product Code	Cell Size	Length (m)	Height (m)	Width (m)	Total Area (m ²)	Weight (kg)
MCL-100-30	488mm x 406mm	12.19	100mm	2.44	29.74	24.7

BENEFITS

- Provides optimum root lock-up for vegetation, creating a more stable vegetated mass and a healthier soil environment
- Mimics natural drainage patterns within the soil
- Can be filled with topsoil to support various types of vegetation
- Suitable for a range of aggregates, from sand and gravel to larger rock or stone
- Compatible with concrete of various strengths and surface finishes
- Can be backfilled with on-site available fill materials
- Allows for a combination of fill types to meet specific project requirements

The Mira-Cell Cellular Confinement System features an engineered pattern of perforations in the cell walls. This perforation pattern enhances resistance to soil erosion by allowing lateral water flow while maintaining structural integrity.

Two cell sizes—large and small—are available, along with a variety of cell heights to suit specific project needs. Our stocked size is listed below.



BIOTEK BRUSHWOOD BALES

PRODUCT CODE

BL3024
1 tonne

BioTek™ Brushwood is a proven solution for erosion control and riverbank restoration, especially when paired with BioTek™ erosion control mattings. It can be spread and secured across riverbanks or used to build check structures, riverbank walls, and channels, while managing stream flow. Lightweight, easy to install, and 100% biodegradable, BioTek™ Brushwood blends naturally into the environment and provides protection until vegetation is established. Supplied in 1-tonne lots. Each cutting is approx. 2.5m long with 20–40mm diameter branches.

Note: Cut to order. Please allow 2–4 weeks lead time.



BIOTEK BRUSHWOOD LOG

PRODUCT CODE

BL2030
20cm x 3m

These logs offer an effective solution for erosion control on slopes and riverbanks. They can be used to build riverbank walls, construct check structures, manage stream flow velocity, or shape channels. BioTek™ Brushwood Logs are lightweight, easy to install, and naturally blend into the environment over time. They provide protection until natural vegetation is established and are made from a 100% biodegradable, renewable resource. Sold in pallets of 40 logs.





SECTION 5

NUSERY AND PLANT PROPAGATION



ROOT PRUNING POTS

PRODUCT CODE

GDP199

8L - 200mm diameter X 250mm high

GDP200

18L - 300mm diameter X 250mm high

GDP203

45L - 400mm diameter X 350mm high

Our range of two-part root trainer air-pruning pots includes an open mesh base and removable sidewalls. The sidewalls feature a unique dimpled and perforated design that channels roots toward the openings, where they are naturally air pruned. This process eliminates root spiralling and encourages lateral branching, resulting in a denser, healthier root system. The perforations also promote better oxygenation within the root zone.



CLONEX GREEN GEL

PRODUCT CODE

CLOGRE1

1L

CLOGRE5

5L

Clonex was the world's first gel-based rooting compound and remains a trusted choice for both commercial and hobby growers. This high-performance gel contains a blend of rooting hormones, vitamins, nutrients, and fungicides to support strong and consistent root development. Clonex Green is specially formulated for softwood cuttings, providing a stable and nutrient-rich environment that promotes fast, healthy root growth.

CLONEX PURPLE GEL

PRODUCT CODE

CLOPUR1

1L

CLOPUR5

5L

Clonex was the world's first gel-based rooting compound and remains a trusted choice for both commercial and hobby growers. This high-performance plant-rooting gel contains a balanced blend of hormones, vitamins, nutrients, and fungicides to promote strong, consistent root development. Clonex Purple is easy to use, with a unique formula that initiates root growth while nourishing the plant. Ideal for all medium wood cuttings.



CLONEX RED GEL

PRODUCT CODE

CLORED1

1L

CLORED5

5L

Clonex was the world's first gel-based rooting compound and is trusted by both commercial and hobby growers for consistent, superior results. Clonex Red is a high-performance, gel-based formulation containing premium hormones, vitamins, nutrients, and fungicides—specifically designed for use on all hardwood cuttings.



ESI-ROOT PROPAGATING SOLUTION

PRODUCT CODE

- ERG50**
50ml
- ERG500**
500ml

Esi-Root Propagating Gel is a commercial-strength rooting hormone formulated to support fast, reliable root development across a wide range of plant species. Designed for professional propagation, Esi-Root is suitable for use on softwood, semi-hardwood, and hardwood cuttings, making it a versatile solution for nurseries, landscapers, and serious home growers.



TREE WOUND DRESSING

PRODUCT CODE

- TW300**
300ml
- TW500**
500ml
- TW2000**
2L
- TW10000**
10L

Ideal for preventing disease in recently pruned trees and plants. Applied immediately after pruning, it seals and protects the wound while still allowing the bark to breathe. Also commonly used to paint root balls during transplanting.



SEED AND CHEMICAL SCALES

PRODUCT CODE

- SJ1000HS**
0.5g increments

Perfect for accurately weighing lightweight products such as seeds and concentrated chemicals, these precision portion control scales measure up to 1kg in 0.5-gram increments. Designed for reliability and ease of use, they feature a fast response time, full digital calibration, and a large 25mm LCD for clear readings. The durable casing and large stainless steel weighing pan (230 x 190mm) ensure long-term performance, while the built-in spirit level and adjustable feet provide enhanced stability. Operates via AC adaptor or batteries, with automatic power-off functionality to conserve energy. Compact and lightweight, with overall dimensions of 265 x 250 x 103mm.



PERLITE

PRODUCT CODE

- P300**
Fine Grade
- P400**
Medium Grade
- P500**
Coarse Grade

An ideal growing medium for horticultural use, Perlite improves soil porosity and aeration, helping air reach even the most delicate root systems. It also increases the soil's capacity to retain moisture, supporting healthy plant growth. Lightweight, sterile, non-toxic, and pH neutral, Perlite is easy to handle and mix into various soil types. Available in fine, medium, and coarse grades. Supplied in 100L bags.



PHYTOCLEAN DISINFECTANT CLEANER

PRODUCT CODE

PHYTO5
5L

PHYTO20
20L

PHYTO200
200L

Phytoclean is a revolutionary disinfectant cleaner, specifically formulated for the control of *Phytophthora cinnamomi* (dieback spores). It is an effective general-purpose microbiocide and algicide, and is classified as a non-hazardous product.

Phytoclean delivers significantly faster performance and kill time compared to sodium hypochlorite or phenolic-based products—effective in as little as 30 seconds. It can be used in footbaths, high-pressure or automatic machine wash-downs, and for spraying or wiping hard surfaces and tools.



ENVY ANTI-TRANSPIRANT

PRODUCT CODE

E60070
1L

E5000
5L

E40773
20L

Envy Anti-Transpirant helps protect plants by reducing moisture loss by up to 50%, preventing sun and windburn damage, and increasing frost resistance by up to 4°C. It does not impede plant growth or photosynthesis, is non-toxic, pH neutral, and biodegrades naturally in sunlight.

Ideal for use during transplanting or transport, for indoor plants, or in extreme conditions such as heat, wind, or frost. Keep your plants green with Envy!



TUBESTOCK TUBES

PRODUCT CODE

NT50RT
50x50x120mm, tapered, 1,000/box



TUBESTOCK TUBE HOLDING TRAY

PRODUCT CODE

NTT
Holds 50 Tubes



SEEDLING TRAY

PRODUCT CODE

ST88B
88 cells 42x42mm x 70mm deep cells



ALUMINIUM PLANT TAGS

PRODUCT CODE

GD751
100mm x 20mm, 1,000/carton.



NORWOOD STAKE

PRODUCT CODE

N2341
32cm h, 10cm x 7cm plate

N2323
53cm h, 16cm x 13cm plate

N2333
34cm h, 15cm x 10cm plate



PLASTIC PLANT TAGS

PRODUCT CODE

PTW500
100mm x 20mm, 500/box

PTWBULK
100mm x 20mm, 5,000/box



WEEDMAXX WEED CONTROL MATTING

StrataGreen supplies weed control matting for use in landscaping and nursery applications. The robust woven polypropylene construction is UV-stabilised and suitable for outdoor use. WeedMaxx is available in two grades: 85gsm and 114gsm.

The 85gsm grade is ideal for most landscape applications where the product is primarily covered with mulch and subject to limited foot traffic. The more robust 114gsm grade is better suited for nursery applications where the matting is exposed to direct sunlight and frequent foot traffic.

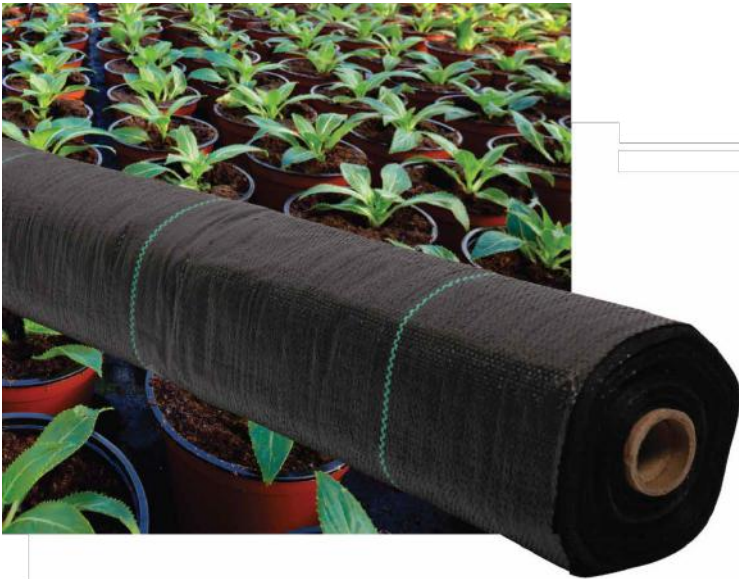

Product Code	Sizing
WCM900	0.9m x 50m roll, 85gsm
WCM1830	1.83m x 50m roll, 85gsm
WCM3660	3.66m x 50m roll, 85gsm
WCMP1830	1.83m x 50m roll, 114gsm
WCMP3660	3.66m x 50m roll, 114gsm
WMPP09	910mm X 10m roll, 85gsm
WMPP18	1830mm X 10m roll, 85gsm

CHEMJET TREE INJECTOR

PRODUCT CODE

CJT101

The Chemjet® Injector is a spring-loaded device featuring a 20mm tapered nozzle to assist with easy insertion into the tree. Similar to a syringe, the chemical is drawn into the injector chamber in measured quantities of 10, 15, or 20ml. Once filled, the injector is locked by turning the handle clockwise.



Tree injection aims to utilise the tree's natural transport system to distribute pesticides, fungicides, and fertilisers directly to where they are most effective—without releasing chemicals into the surrounding environment.

EASY-TIE RUBBER TREE TIES

PRODUCT CODE

ETP130

130mm x 2.5mm (25/Pk)

ETP170

170mm x 4mm (25/Pk)

ETP300

300mm x 6mm (10/Pk)

ET130

130mm x 2.5mm (500/Pk)

ET170

170mm x 4mm (500/Pk)

ET300

300mm x 6mm (200/Pk)

These innovative products expand as your plants grow and can be easily released and re-fastened. Made from a durable compound for maximum stretch and strength, they have a long life expectancy of 3–5 years.





SHADEMAXX SHADECLOTH

ShadeMaxx is a premium quality knitted shadecloth that is UV stabilised and guaranteed for 10 years.

EXTRA HEAVY - 90%

Product Code	Colour	Roll Size
SCEH1830B	Beige	1.83m x 30m
SCEH1830BL	Black	1.83m x 30m
SCEH1830CH	Charcoal	1.83m x 30m
SCEH1830G	Green	1.83m x 30m
SCEH1830LG	Light Green	1.83m x 30m
SCEH1830LGY	Light Grey	1.83m x 30m
SCEH3660B	Beige	3.66m x 30m
SCEH3660BL	Black	3.66m x 30m
SCEH3660CH	Charcoal	3.66m x 30m
SCEH3660G	Green	3.66m x 30m
SCEH3660LG	Light Green	3.66m x 30m
SCEH3660LGY	Light Grey	3.66m x 30m

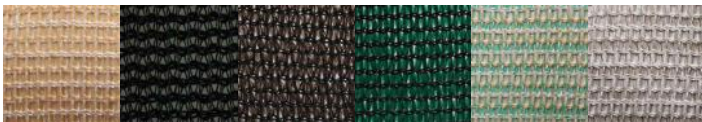

MEDIUM - 70%

Product Code	Colour	Roll Size
SCM1830B	Beige	1.83m x 30m
SCM1830BE	Blue	1.83m x 30m
SCM1830BL	Black	1.83m x 30m
SCM1830G	Green	1.83m x 30m
SCM1830T	Terracotta	1.83m x 30m
SCM1830W	White	1.83m x 30m
SCM3660B	Beige	3.66m x 30m
SCM3660BE	Blue	3.66m x 30m
SCM3660BL	Black	3.66m x 30m
SCM3660G	Green	3.66m x 30m
SCM3660T	Terracotta	3.66m x 30m
SCM3660W	White	3.66m x 30m

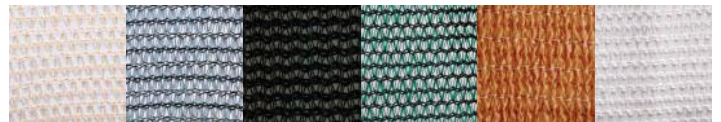

LIGHT - 50%

Product Code	Colour	Roll Size
SCL1830B	Beige	1.83m x 30m
SCL1830BL	Black	1.83m x 30m
SCL1830G	Green	1.83m x 30m
SCL1830W	White	1.83m x 30m
SCL3360B	Beige	3.66m x 30m
SCL3360BL	Black	3.66m x 30m
SCL3360G	Green	3.66m x 30m
SCL3360W	White	3.66m x 30m

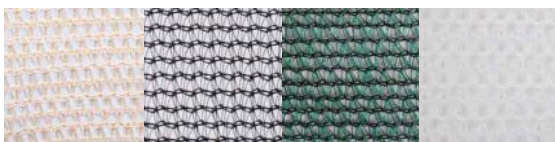

SHADEMAXX CLOTH FASTENERS

Product Code	Colour	Packing
RSCF50	Green	50/box
RSCF50B	Beige	50/box
RSCF50Z	Zinc	50/box





RYSET FIELD GRAFTING TOOL

PRODUCT CODE

GT572

A robust, hand-operated tool that takes the guesswork out of grafting. The combination grafting pliers come with interchangeable blades for both omega/slot grafting and bud grafting, making it ideal for a variety of applications. Simply place the scion on the anvil to cut a precise V-shape, then repeat on the rootstock and join.

The tool can cut rootstock up to 14mm in diameter and includes a chip budding attachment. Spare blades and anvils are available, and all parts are replaceable. Perfect for gardeners, hobby grafters, and small horticultural operations.



BUDDING AND GRAFTING TAPE

PRODUCT CODE

DUGRA12
12mm

DUGRA25
25mm



This premium-grade, Australian-made budding and grafting tape is widely used by horticultural professionals. Its lightly embossed surface provides excellent grip and flexibility, even in hot or humid conditions, making application easier and faster—helping reduce labour time and costs. Available in white, in 50m rolls, with two width options: 12mm and 25mm.

SONO TAPE TOOL

PRODUCT CODE

NJ99

The Sono Tape Tool is an indispensable solution for quickly and easily tying small plants, vines, and vegetables. It ties, staples, and cuts in one smooth, single-handed operation, saving time and effort in the garden or nursery. Supplied with a bonus box of staples, and with additional tape and staples available, it's a reliable and efficient choice for plant training and support.



DURA TAPENER TAPE

PRODUCT CODE

DT15
15cm

This green tapener tape is designed for use with tapener guns and is made from 15µm PVC material. Each box contains 10 rolls, with 26 metres per roll, providing a practical and economical solution for tying plants securely and efficiently.

STAPLES FOR TAPENER GUN

PRODUCT CODE

DUS1000

These are genuine replacement staples for tapener guns, packaged with 10,000 staples per box. Designed for reliable performance, they ensure smooth and consistent operation when securing plants with a tapener tool.



VOLPI CORDLESS TYING MACHINE

PRODUCT CODE

KV5

The KV5 is a high-performance cordless tying machine from Volpi Originale, designed for fast, precise tying with minimal effort. Featuring a brushless motor and rechargeable lithium battery, it delivers hours of reliable operation for vineyards, berry farms and nurseries.

An ergonomic handle, easy-change wire coils and an integrated magnetic tension system ensure consistent results. A digital display shows battery level and tie count, while adjustable revolutions (2–6) and two speed settings allow flexibility across different shoot sizes.

Supplied in a durable carry case with two batteries, charger, holster, wire spools, scissors and repair kit. Backed by a 24-month warranty for private use and 12 months for professional use.



BAMBOO CANES

StrataGreen stocks a wide range of natural bamboo canes, ideal for nursery staking, bush regeneration, and revegetation projects. These strong, durable canes are a lightweight and cost-effective alternative to hardwood stakes, perfect for supporting small to medium plants, seedlings, and young trees.

Available in various sizes, our bamboo canes are easy to install and blend naturally into any garden or landscape. Their sturdy yet flexible structure provides excellent support, helping plants grow strong and upright.

Whether you're working on a large-scale revegetation site or simply supporting climbing plants in your garden, StrataGreen's Natural Bamboo Canes offer a reliable solution for all your plant support needs.



Product Code	Sizing	Packing
BC6845	6-8 x 450mm	1,000/Bale
BC101260	10-12 x 600mm	500/Bale
BC121460	12-14 x 600mm	250/Bale
BC81075	8-10 x 750mm	500/Bale
BCP81090	8-10 x 900mm	20/Pieces
BC101275	10-12 x 750mm	500/Bale
BCP1012120	10-12 x 1200mm	15/Pieces
BCP121475	12-14 X 750mm	20/Pieces
BC121475	12-14 x 750mm	250/Bale
BC141675	14-16 x 750mm	250/Bale
BC161875	16-18 x 750mm	100/Bale
BCP1618180	16-18 x 1800mm	10/Pieces
BC232575	23-25 x 750mm	100/Bale
BC81091	8-10 x 910mm	500/Bale
BC111391	11-13 x 910mm	250/Bale
BC1113120	11-13 x 1,200mm	250/Bale
BC1416120	14-16 x 1200mm	200/Bale
BC2022120	20-22 x 1200mm	100/Bale
BC1517150	15-17 x 1,500mm	200/Bale
BC2022150	20-22 x 1500mm	100/Bale
BC16181800	16-18 x 1,800mm	100/Bale
BC2022180	20-22 x 1,800mm	100/Bale
BC20222400	20-22 x 2400mm	50/Bale



WOVEN PLANTER BAGS

If you're after a cost-effective, durable, and easy-to-use planter solution, these heavy-duty planter bags are ideal. Designed for home growers, professional gardeners, councils, nurseries, and more, they are made from high-quality woven plastic material with UV protection to ensure years of reliable use. These bags are long-lasting, highly resistant to tears and leaks, and provide a great alternative to traditional pots. Available in a range of sizes to suit every application.

Product Code													
PB15L	PB20L	PB25L	PB25LT	PB35L	PB45L	PB75L	PB100L	PB150L	PB200L	PB300L	PB400L	PB500L	PB1000L
15L	20L	25L	25L	35L	45L	75L	100L	150L	200L	300L	400L	500L	1000L



Litre	Handle Configuration	Fabric	Size	Fabric gsm	Qty/bale
15	2 Handles Standard	HDPE 4 cm	26cm Dia x 30cm H	140	300
20	2 Handles Standard	HDPE 4 cm	32cm Dia x 25cm H	140	250
25	2 Handles Standard	HDPE 4 CM	34cm Dia x 28cm H	140	200
25 TALL	2 Handles Standard	HDPE 4 CM	30cm Dia x 35cm H	140	200
35	2 Handles Standard	HDPE 4 CM	37cm Dia x 33cm H	140	180
45	2 Handles Standard	HDPE 4 CM	38cm Dia x 40cm H	140	100
75	2 Handles Standard	HDPE 7 CM	46cm Dia x 46cm H	140	75
100	4 Handles Standard	HDPE 7 CM	51cm Dia x 50cm H	200	50
150	4 Handles Standard	HDPE 7 CM	60cm Dia x 54cm H	200	40
200	4 Handles Standard	HDPE 7 CM	65cm Dia x 60cm H	200	30
300	4 Handles Standard	HDPE 7 CM	80cm Dia x 60cm H	200	20
400	4 Handles, Long Belt	HDPE 7 CM	92cm Dia x 60cm H	200	20
500	4 Handles, Sling Belt	HDPE 7 CM	95cm Dia x 75cm H	200	15
1000	4 Handles, Sling Belt + Perimeter Belt	HDPE 7 CM	120cm Dia x 90cm H	240	10



BALE OF COCOPEAT COIR PITH

PRODUCT CODE

CCP200
200L

Our 100% washed Cocopeat Coir Pith is a sustainable and environmentally responsible solution for all your gardening needs. Carefully cleaned and completely pathogen-free, it provides a safe, healthy growing medium for your plants. With a pH level of 6, it offers the ideal balance to support strong, healthy growth while promoting water conservation and reducing environmental impact.



COCOPEAT COIR PITH BLOCK

PRODUCT CODE

CCP1005
5kg

Designed with water conservation and environmental responsibility in mind, our coir growing media offers a natural, chemical-free alternative for gardeners and growers. Made from 100% organic material, it's an eco-friendly choice that supports healthy plant growth while helping to protect water quality and preserve surrounding ecosystems.

COIR COCOBLEND 60/40 (PEAT/CHIP) BLOCK

PRODUCT CODE

CB60405
5kg

Coir Cocoblend 60/40 is expertly formulated to meet the needs of pot plant growers. Featuring a precise blend of 60% coco pith and 40% coco chip, this premium growing medium delivers excellent drainage and aeration. With a low EC of less than 1 mS/cm (at 1:1.5 dilution), it ensures optimal nutrient availability for healthy root development and vigorous plant growth. Ideal for growers who value quality, consistency, and performance.



COIR COCOCHIP BLOCK

PRODUCT CODE

CC1005
5kg

The Coir Cocochip Block is a sustainable and eco-conscious choice for gardeners looking to conserve water and promote healthy plant growth. Made from high-quality, 100% natural materials, it's free from harmful chemicals and additives. With a low EC of less than 1 mS/cm (at 1:1.5 dilution), it ensures a balanced nutrient environment for optimal plant development. This environmentally friendly growing medium supports a healthier garden and contributes to a more sustainable future.

SPHAGNUM PEAT MOSS

PRODUCT CODE

TEEM220
220L

Our 100% natural Sphagnum Peat Moss is an ideal choice for improving soil health and productivity. Sourced from natural peat bogs by Global Axis, this organic material is free from harmful chemicals and additives, making it perfect for environmentally conscious gardeners. Easy to use, it enhances soil structure, boosts water retention, and improves nutrient availability. It also supports healthy root development, helping your plants thrive naturally and effectively.





SECTION 6

REVEGETATION AND TREE PLANTING



EKOTEK FLUTED TREE GUARDS

PRODUCT CODE

TGW450

Height: 450mm | Sides: 200mm | Pack Qty: 50

TGW600

Height: 600mm | Sides: 200mm | Pack Qty: 50

Stratagreen Fluted Tree Guards are a durable and reusable alternative to traditional plastic sleeves. Made from robust fluted sheet, they're designed to save installation time and can be used season after season. Each guard comes pre-split at the back to accommodate a hardwood or bamboo stake and features a tabbed design that allows it to be easily opened and installed around existing trees.



EKOTEK MESH SAPLING GUARD

PRODUCT CODE

PTG4525

Height: 440mm | Sides: 170mm | Packing: 200qty

The Mesh Sapling Guard is a cost-effective solution for protecting young trees and shrubs, especially in hot, dry areas where maximum ventilation is essential. Light green in colour to blend with the environment, these guards are easy to install and typically supported with three bamboo canes. Their lightweight, open-mesh design promotes airflow while providing reliable protection during early growth stages.

EKOTEK TREE GUARD SLEEVES

PRODUCT CODE

TS4535

Height: 450mm | Sides: 230mm | Packing: 500qty

TS4540

Height: 450mm | Sides: 267mm | Packing: 500qty

These Tree Guard Sleeves are a practical and reliable option for protecting young seedlings from harsh weather and small browsing animals. Widely used in gardening, landscaping, and bush regeneration projects, they are designed for use with three bamboo canes to provide sturdy support and effective protection during the crucial early stages of growth.



MALLEE ELEMENTAL™ 65 TREE GUARD

PRODUCT CODE

TSELEMENT4520-65

Height: 450mm | Sides: 200mm | Packing: 10qty

The Mallee Elemental™ Tree Guards are a sustainable alternative to traditional fluted guards, made using 65% less plastic without compromising on durability or performance. Designed for growers who want to reduce environmental impact without sacrificing protection, they offer a smarter, greener way to support young tree growth.

BIOTEK CARTON TREEGUARDS

PRODUCT CODE

PLMC2

2L | Height: 300mm | Sides: 95mm | Packing: 250qty

Carton Treeguards are a cost-effective and environmentally friendly solution for protecting fast-growing young trees. Made from 2-litre biodegradable cardboard, they offer reliable shelter for tube stock during early growth, making them ideal for large-scale revegetation projects. Easy to install with just two bamboo canes per guard, they provide stable protection and gradually break down into the soil over time, reducing environmental impact.





BIOTEK BIOGUARD COIR TREE GUARD

PRODUCT CODE

BG4535

Height: 450mm | Sides: 230mm | Packing: 100qty

The BioTek BioGuard Coir Tree Guard is a durable and eco-friendly solution for protecting young seedlings from harsh weather, pests, and browsing animals. Made from natural coir fibre with a weatherproof binder, it provides up to 12 months of protection before gradually biodegrading into the soil. Its robust, non-woven construction resists tearing, and with no folding required, installation is quick and simple using just two bamboo canes. Ideal for bush regeneration, forestry, and large-scale planting projects.



BIOTEK HESSIAN TREE SLEEVES

PRODUCT CODE

HTS450

Height: 450mm | Sides: 230mm | Packing: 50qty

BioTek Hessian Tree Sleeves offer an environmentally friendly solution for protecting young plants. Made from biodegradable hessian derived from natural jute fibres, these guards require no removal, as they naturally break down over time—enriching the soil as they decompose. Designed for easy installation, each sleeve is supported with three bamboo canes or wooden stakes, making them ideal for bush regeneration, landscaping, and revegetation projects.



NATURGUARD BIO TREE GUARD

PRODUCT CODE

BIO9595

Mini Bio | Height: 300mm | Sides: 95mm | Packing: 250qty

BIO4535

Bio | Height: 450mm | Sides: 200mm | Packing: 150qty

BIO6035

Bio Max | Height: 600mm | Sides: 200mm | Packing: 150qty

The NaturGuard BIO Treeguard is an innovative, Australian-made solution for protecting plants and saplings during their first year of growth. Made from 100% biodegradable stock and certified to TUV home compostability standards, it breaks down naturally without harming the environment. Designed for easy installation with a staking slot at the back, it offers reliable protection while supporting sustainable land care practices.



ECOMESH TREE GUARD

PRODUCT CODE

ECOMSH500

Height: 500mm | Sides: 1mm | Packing: 200qty

Give your plants the protection they need, without the plastic. Eco-Mesh is a biodegradable tree guard designed to shield young trees and shrubs from browsing animals while naturally breaking down over time. Made from plant-based fibre mesh, Eco-Mesh provides short-term protection when it matters most, then decomposes into the soil, leaving nothing behind.



Ideal for revegetation, landscaping, and eco-restoration projects where sustainability is key.

FEATURES AND BENEFITS

- Size: 270mm wide (laid flat) x 500mm tall
- Material: Natural, biodegradable mesh
- Protection: Guards against animal browsing
- No Plastic Waste: Made from eco-friendly PLA+PBAT bio-polymers
- Easy Installation: Use with hardwood stakes or large bamboo canes
- Low Maintenance: No need for removal or disposal



GREENGUARD RANGE

GREENGUARD products are proudly designed and manufactured in Australia by Growise Pty Ltd, combining local expertise with a strong commitment to sustainability. Both recyclable and biodegradable, these guards offer effective tree protection while minimising environmental impact. Choosing GREENGUARD means supporting eco-friendly innovation without compromising on quality or performance.



GREENGUARD TRIANGULAR TREE GUARDS

PRODUCT CODE

GGPOP450T

Large (POP) | 450mm H x 200mm W | Packing: 50qty

GGPOP600T

Maxi | 600mm H x 220mm W | Packing: 25qty

GREENGUARD-POP is a sustainably designed tree guard that offers superior protection with a clever Pop-Out design for quick and easy installation and removal. With a field life of over 12 months, it provides reliable, long-lasting defence for young trees, helping them establish and thrive while supporting environmentally responsible practices.

GREENGUARD SQUARE TREE GUARDS

PRODUCT CODE

GGMINI320

Mini | 320mm H x 110mm W | Packing: 50qty

GGMID350

Midi | 350mm H x 150mm W | Packing: 50qty

GGPOP450S

Large (POP) | 450mm H x 150mm W | Packing: 50qty

GREENGUARDS offer sustainable and durable protection for young trees, ideal for environmentally conscious gardeners and landscapers. Made from a proprietary plastic-free, weather-resistant board, they are designed to withstand the elements. Fully recyclable and biodegradable, GREENGUARDS provide reliable performance while supporting eco-friendly practices.



GREENGUARD SKIPPY SQUARE TREE GUARD

PRODUCT CODE

GGSKIP885

885mm H x 178mm W | Packing: 25qty

The GREENGUARD-SKIPPY is a tall, square biodegradable tree guard specifically designed to protect young trees from kangaroos and wallabies. Proudly made in Australia, it's crafted from a proprietary, plastic-free, weather-resistant board that is both durable and environmentally responsible. Fully recyclable and 100% biodegradable, it offers reliable protection without compromising sustainability.

GREENGUARD 360 ROUND TREE GUARD

PRODUCT CODE

GG360

450mm H x 660mm W | Packing: 50qty

The GREENGUARD-360 is a durable, eco-friendly tree guard designed to protect young saplings in landscaping and reforestation projects. Made from a plastic-free, weather-resistant board, its flat-pack, pop-out design allows for quick assembly and reliable protection in the field for 12 months or more. A sustainable solution that balances performance with environmental responsibility.





JUTE TREE SQUARES

PRODUCT CODE

JTS370
370mm x 370mm | Packing: 100/bale

Tree Squares are an effective solution for suppressing weeds and conserving moisture around young trees as they establish. Designed with a centre split for easy placement, these 370mm squares are a practical choice for efficient planting. Supplied in standard bales of 100, they're ideal for large-scale landscaping and revegetation projects.



BAMBOO CANES FOR TREE SLEEVES

PRODUCT CODE

BC121475
12-14 x 750mm | Packing: 250/bale

StrataGreen's Natural Bamboo Canes offer a strong, lightweight, and cost-effective solution for supporting young trees, seedlings, and climbing plants. Ideal for gardening, landscaping, and bush regeneration, they provide a natural aesthetic that blends seamlessly into any environment. A sustainable alternative to hardwood stakes, these versatile canes are available in a range of sizes to suit various applications.



VINE GUARD

PRODUCT CODE

VG450W
450mm H x 135mm W | White | 200um

This economical vine guard is designed to protect young vines and seedlings from spray drift, harsh winds, and light frost. Supplied on a continuous roll perforated every 450mm for quick separation, each guard measures 135mm wide by 450mm high. Available in white, it's ideal for vineyards, nurseries, revegetation projects, and broadacre plantings, providing reliable protection while supporting healthy plant growth. 600 Guards per roll.



SENTREE SAPLING PROTECTOR

PRODUCT CODE

ST230
Height: 230mm | Packing: 100/carton

Sentrees protect young trees from damage caused by line trimmers, rodents, and lawnmowers. They come tightly coiled for easy installation around tree trunks and can be linked together for larger trees. Measuring 230mm in height, Sentrees are supplied in boxes of 100, offering reliable protection for your planting projects.

GREENWELL TREE SURROUND

PRODUCT CODE

GWELLB
430mm x 190mm | Black | Capacity: 26L

GWELL2B
600mm x 250mm | Black | Capacity: 50L

GWELLG
430mm x 190mm | Green | Capacity: 26L

GWELL2G
600mm x 250mm | Green | Capacity: 50L

Greenwell is designed for commercial urban tree specialists to improve tree health by directing water and nutrients to the root zone, reducing runoff and encouraging deeper root growth. It also protects trees from damage caused by trimming tools and mowers, retains mulch, and is ideal for planting on slopes. Made from recycled plastic and reusable, Greenwell carries the Smart Approved Watermark for water conservation. Available in two sizes—Standard (430mm diameter x 190mm high, 26L) and Large (600mm diameter x 250mm high, 50L)—and in green or black.





TIMBER STAKES FOR TREE PLANTING

StrataGreen stocks Western Australian hardwood stakes suitable for a wide range of tree planting applications—from long-lasting support for seedlings to robust staking for mature trees in verge and urban environments. Available in 25x25mm, 38x38mm, and 50x50mm dimensions across various lengths, with custom sizes available on request.



HARDWOOD STAKES

Product Code	Description	Sizing
JTS25250600	Pointed Hardwood Stake	25 x 25 x 600mm
JTS25250750	Pointed Hardwood Stake	25 x 25 x 750mm
JTS25250900	Pointed Hardwood Stake	25 x 25 x 900mm
JTS25251200	Pointed Hardwood Stake	25 x 25 x 1,200mm
JTS25251500	Pointed Hardwood Stake	25 x 25 x 1,500mm
JTS25251800	Pointed Hardwood Stake	25 x 25 x 1,800mm
JTS38381200	Pointed Hardwood Stake	38 x 38 x 1,200mm
JTS38381500	Pointed Hardwood Stake	38 x 38 x 1,500mm
JTS38381800	Pointed Hardwood Stake	38 x 38 x 1,800mm
JTS38382100	Pointed Hardwood Stake	38 x 38 x 2,100mm
JTS38382400	Pointed Hardwood Stake	38 x 38 x 2,400mm
JTS50500750	Pointed Hardwood Stake	50 x 50 x 750mm
JTS50501800	Pointed Hardwood Stake	50 x 50 x 1,800mm
JTS50502100	Pointed Hardwood Stake	50 x 50 x 2,100mm
JTS50502400	Pointed Hardwood Stake	50 x 50 x 2,400mm

HARDWOOD SURVEY PEGS

Product Code	Description	Sizing
JSS50500750	Survey Peg, White Top	50 x 50 x 750mm
JSS25250600	Survey Peg, White Top	25 x 25 x 600mm
JSS25250900	Survey Peg, White Top	25 x 25 x 900mm

HARDWOOD STAKES FOR COREFLUTE GUARDS

These premium-grade mahogany stakes are the ideal support solution for use with fluted plastic tree guards. Strong, durable, and long-lasting, they provide reliable stability for young trees in various planting environments.

Product Code	Sizing
HTS15250750	15mm x 25mm x 750mm
HTS25250750	25mm x 25mm x 750mm
HTS11380750	11mm x 38mm x 750mm
HTS15250900	15mm x 25mm x 900mm



BLACK PAINTED TREE STAKES

StrataGreen offers a professional tree stake painting service using high-quality exterior-grade acrylic. This service is available for all our hardwood stakes, providing a clean, uniform look for your project. Lead times apply, so please contact our sales team for details. Please note: this service is not available for pine stakes.

Product Code	Sizing
JTS50501800B	50 x 50 x 1,800mm
JTS50502100B	50 x 50 x 2,100mm
JTS50502400B	50 x 50 x 2,400mm





ARBORTAB TREE PLANTING TABLETS

These compact, easy-to-use fertiliser tablets take the guesswork out of measuring dry materials and provide a safe, complete nutrient source for up to 12 months. Designed to support vigorous root and top growth during a plant's critical first year, these tablets ensure a steady release of essential nutrients to promote healthy establishment and long-term vitality.

ARBORTAB NATIVE PLANTING TABLETS

PRODUCT CODE

ARB10

10gram, 10kg (1,000 tablets)

ARB20

20gram, 10kg (500 tablets)

These tablets are suitable for phosphorus-sensitive species such as Banksias and Grevilleas. They contain a very low level of phosphorus.

BENEFITS

- Safe, easy to handle, and convenient
- Arbor Tab Planting Tablets provide a plant growth response for up to twelve months in warm climates – reducing the need for re-application of labour and materials
- The simplicity of pre-measured tablets ensures uniform and adequate fertilisation
- Supervisory time is reduced – count and placement of tablets can be easily verified after installation
- Root zone placement prevents feeding of surface-rooted weeds and grasses, with no surface residue to wash away
- Leach-resistant properties help protect underground water from pollution
- Tablet options are available for both phosphorus-sensitive natives and general trees and shrubs



ARBORTAB GENERAL PURPOSE PLANTING TABLETS

PRODUCT CODE

ARB10

10gram, 10kg (1,000 tablets)

ARB20

20gram, 10kg (500 tablets)

These tablets are suitable for use with general trees and shrubs, and are designed to give your plants a strong, healthy start.



Total Nitrogen (N)	20.07% w/w
Nitrogen (N) as Urea	1.41 % w/w
Nitrogen (N) as Ureaform	17.29 % w/w
Nitrogen (N) as Nitrate	1.00 % w/w
Nitrogen (N) as Ammonium	1.00 % w/w
Total Phosphorous (P)	1.20 % w/w
Water Soluble	0.93 % w/w
Citrate Soluble	0.27 % w/w
Insoluble	N/A
Total Potassium (K)	10.50 % w/w
Sulphur (S) present as Sulphate	4.60 % w/w
Magnesium (mg) as Sulphate	0.45 % w/w
Iron (Fe) as Sulphate	0.36 % w/w
Zinc (Zn) as Sulphate	0.08 % w/w
Copper (Cu) as Sulphate	0.05 % w/w
Manganese (Mn) as Sulphate	0.08 % w/w
Boron (B)	0.01 % w/w
Molybdenum (Mo)	N/A

Total Nitrogen (N)	20.00 % w/w
Nitrogen (N) as Urea	3.55 % w/w
Nitrogen (N) as Ureaform	0.55 % w/w
Nitrogen (N) as Nitrate	0.30 % w/w
Nitrogen (N) as Ammonium	0.30 % w/w
Total Phosphorous (P)	4.40 % w/w
Water Soluble	0.93 % w/w
Citrate Soluble	0.27 % w/w
Insoluble	N/A
Total Potassium (K)	8.0 % w/w
Sulphur (S) present as Sulphate	4.12 % w/w
Magnesium (mg) as Sulphate	0.64 % w/w
Iron (Fe) as Sulphate	0.36 % w/w
Zinc (Zn) as Sulphate	0.32 % w/w
Copper (Cu) as Sulphate	0.31 % w/w
Manganese (Mn) as Sulphate	0.17 % w/w
Boron (B)	0.02 % w/w
Molybdenum (Mo)	0.01 % w/w



MAXILOCK TREE TIE

PRODUCT CODE

GT710

12mm W x 100m L

The Maxilock Tree Tie (12mm W x 100m L) is a simple and secure way to tie young trees to stakes—no knots required. Just push the tie through itself and twist to lock in place. Perfect for nurseries, gardens, and landscaping projects, this lightweight version offers flexibility and control without damaging plants. Made from durable, weather-resistant materials, it's built to last and easy to adjust as your trees grow.



MAXILOCK TREE TIE

PRODUCT CODE

GT720

26mm W x 50m L

The Maxilock Tree Tie (26mm wide x 50m long) is a larger version of the GT710, designed for securing bigger trees. It's easy to use – simply push it through itself and twist to lock. Made from durable materials, it provides strong, long-lasting support to keep trees stable and upright. Ideal for forestry and landscaping professionals, it's a reliable and efficient tree tie solution.



CHAINLOCK RUBBER TREE TIE

PRODUCT CODE

CL5

25mm W x 25m L

The Chainlock Rubber Tree Tie (25mm x 25m) securely fastens trees to stakes while being gentle on stems. Made from UV-stabilized rubber, it's softer than the GT720 Maxilock Tie, reducing damage to young plants. Durable and weather-resistant, it withstands UV rays and harsh conditions for long-lasting use. Perfect for forestry and landscaping, it provides reliable, plant-friendly support.



BIOTEK™ HESSIAN TREE TIE

PRODUCT CODE

JTT5033

50mm W x 33m L

The BioTek Hessian Tree Tie is a biodegradable, natural hessian tie designed to gently support young trees and shrubs. At 50mm wide and 33m long, it provides strong yet flexible support while protecting bark and allowing healthy growth. An eco-friendly choice for gardeners and landscapers.



FLAT TREE TIE

PRODUCT CODE

FT10018

18mm x 100m

FT40018

18mm x 400m

FT10030

30mm x 100m

FT30030

30mm x 300m

Very popular among horticulturists for its versatility and ease of tying, this Tree Tie is made from durable PVC. It offers excellent elasticity, stretching up to 300% of its length, preventing snapping under strain and ensuring the sapling isn't choked as it grows.





EASY-TIE RUBBER TREE TIES

PRODUCT CODE

ETP130

130mm x 2.5mm | Packing: 25qty

ETP170

170mm x 4mm | Packing: 25qty

ETP300

300mm x 6mm | Packing: 10qty

ET130

130mm x 2.5mm | Packing: 500qty

ET170

170mm x 4mm | Packing: 500qty

ET300

300mm x 6mm | Packing: 200qty

These innovative products expand as your plants grow and can be easily released and re-fastened. Made from a durable compound for maximum stretch and strength, they have a long life expectancy of 3–5 years.



EASY-TIE RUBBER TREE STRAP

PRODUCT CODE

GT698

400mm | Packing: 10qty

The Easy-Tie Rubber Tree Strap offers a strong yet flexible solution for securing young trees and saplings. Made from high-quality rubber, these 400mm straps stretch to absorb wind movement and natural growth without harming the tree. Pre-cast holes allow easy nailing to hardwood stakes, providing versatile positioning for various tree sizes and staking needs. Designed for durability, they withstand harsh weather while maintaining elasticity over time. Ideal for landscapers and gardeners alike, these straps ensure stable support, protecting your trees and promoting healthy development.

MAXIFAST HEAVY DUTY STAPLE GUN

PRODUCT CODE

AT-901

The Maxifast Heavy Duty Staple Gun is a robust stapler designed for securely fastening tree ties to timber stakes. Compatible with staples suited for model A1112-2M, this tool makes staking quick and reliable.



TREE POPPER

PRODUCT CODE

PLTPS

Small

PLTPM

Medium

PLTPL

Large

This unique tool is ideal for the instant removal of woody weeds and offers a popular alternative to stem scraping, cutting, or poisoning methods of weed control. Known for its excellent durability and ease of use, it is a favorite among owner-operators and volunteers alike. The tool grasps the weed at the base of the stem and pulls the entire plant out of the ground using a lever principle. The large tree popper provides pulling power equivalent to 10 times the operator's weight. Three sizes are available, with the small tree popper being the best choice for removing large numbers of small seedlings.

REGEN SMOKEMASTER

PRODUCT CODE

RGS10

Used to promote germination in smoke-responsive native plant species. Simply apply to seed trays, seeds, or bushland soil to break dormancy, resulting in remarkable germination rates. It also ensures greater uniformity of germination and healthier seedling growth. Available in 10-litre containers.





TREE STAKE DRIVER

PRODUCT CODE

ESD65

800mm Length

The Tree Stake Driver is a heavy-duty tool crafted from 65mm square steel, designed for driving 38 x 38mm and 50 x 50mm tree stakes. Its durable construction ensures long-lasting performance in bush regeneration, forestry, and landscaping projects. Powder-coated bright red for easy visibility in the field, this 800mm-long driver provides excellent leverage and force for efficient stake installation. A reliable essential for professionals needing quick, effective tree staking.



HAMILTON TREE PLANTER

PRODUCT CODE

HTP505

This sturdy tool is designed for planting tube stock grown in 50mm square forestry tubes. Its hollow dibble extracts a soil plug sized perfectly for the seedling, ensuring efficient and precise planting. Various styles are available on request to suit different tube stock sizes.

POTTIPUTKI TREE PLANTER

PRODUCT CODE

PT45

45mm

PT55

55mm

PT63

63mm

PT75

75mm

The world's leading tree planting tool, developed from over 25 years of planting experience. Made in Finland from high-strength steel, it's ergonomically designed to maximise planting efficiency while minimising planter fatigue. Features include a double spring trigger closing mechanism and adjustable jaws for precise planting depth. Available in four different tube diameters.



EKOTEK ALLOY TROWEL

PRODUCT CODE

GTLTA

Lightweight and comfortable, the EkoTek Alloy Trowel is die-cast from solid aluminium for durability and precision. A standard tool for bush regeneration, it's ideal for planting, transplanting, and general garden use.

TREE PLANTING MATTOCK

PRODUCT CODE

C634802

Timber Handle

A compact and durable tool designed for efficient planting of tube stock. Fitted with a sturdy timber handle it offers excellent control and comfort, making it ideal for bush regeneration and landscaping projects.





KIDNEY PLANTING BUCKET

PRODUCT CODE

KPB

Single Bucket Harness

KPB2

Twin Bucket Harness

Designed for efficient field planting, these heavy-duty kidney-shaped trays are ideal for carrying tube stock. Available in both single and twin bucket configurations, each includes a comfortable waist and shoulder harness for balanced support during extended use.



PLANTING BAG SYSTEM

PRODUCT CODE

PBS565

Twin Bag Harness

A durable, Australian-made planting bag system designed for carrying seedlings while planting. Constructed from tough PE canvas, it features two spacious bags (30cm diameter x 38cm deep) and a padded shoulder harness with hip belt to evenly distribute weight for all-day comfort.

BUSHPRO PLANTING SPADES

PRODUCT CODE

PC290

Ultra-light and built for speed, these professional tree planting spades feature polished stainless steel blades for strength and durability. Designed with kickers flush to the back of the blade for smooth operation and efficient planting in all soil types.



TREE COACH®

Tree Coach® is a world-first, sustainable all-in-one tree planting, staking, watering, and protection solution for your natural assets. Proudly Australian-made, Tree Coach® is manufactured from recycled kerbside waste and offers a lightweight, safer-to-install alternative to traditional systems. It supports strong tree caliper and root plate development, helping reduce tree failures, while its consistent and appealing design enhances the visual impact of urban development projects.

Product Code	Sizing	Base Frame Upper Ring	Approx. Planting Depth	Weight	Watering Bowl Capacity	Suggested Root Ball Size
STCB-BR	1200 X 70 X 40	400mm / 65mm	300mm	900G	10 Litres	20cm pots to 18L containers
LTCB-BR	1800 X 100 X 55	550mm / 100mm	450mm	1800G	25 Litres	18L to 45L containers
MTCB-BR	1800 X 100 X 55	650mm / 120mm	600mm	2000G	41 Litres	>45L to 100L containers





POWERTECH HONDA GX35 POST DRIVER

PRODUCT CODE

PPD-80

The Powertech Honda GX35 Post Driver 80 is the lightest and most efficient driver in the Powertech range, weighing just 14kg. Designed for ease of use and portability, it's ideal for driving star pickets and small posts with minimal effort. Powered by the dependable Honda GX35 4-stroke engine, this post driver delivers reliable performance, making fencing jobs faster, easier, and more efficient.

POWERTECH HONDA GX50 POST DRIVER

PRODUCT CODE

PPD-100

The Powertech Honda GX50 Post Driver 100 is a versatile, commercial-grade tool built for fencing contractors, farmers, and tradespeople who value performance and durability. Powered by the dependable Honda GX50 4-stroke engine, it drives everything from star pickets to 100mm pine fence posts with ease—making it ideal for both large-scale and everyday fencing applications.



POWERTECH HONDA GX50 POST DRIVER

PRODUCT CODE

PPD-120

Nicknamed 'The Hulk', the Powertech Honda GX50 Post Driver 120 is the ultimate powerhouse in post driving. Specifically designed for the commercial fencing industry, this heavy-duty tool is the largest in the Powertech range—built to handle the most demanding jobs with ease. Engineered for tough applications, it effortlessly drives everything from small wooden stakes and star pickets to larger steel and wooden strainer posts, including compatibility with the Rotech Drive-Tight Strainer Post.

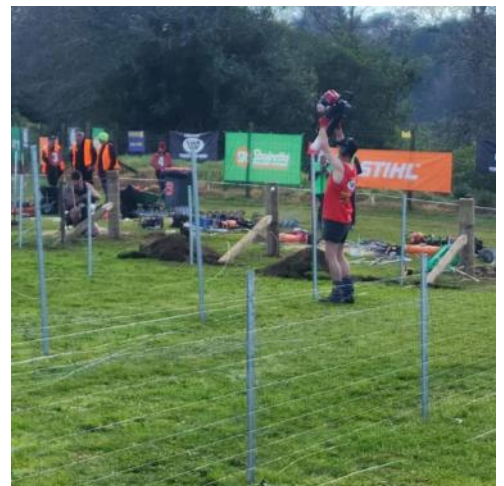



SECTION 7

**GEOSYNTHETIC AND
DRAINAGE PRODUCTS**



GEOTEK™ NON-WOVEN GEOTEXTILE

The GeoTek™ range of needle-punched, non-woven geotextiles is manufactured from 100% polyester continuous filaments. They are characterised by high resistance to installation damage, excellent water permeability, and natural UV resistance.

GeoTek™ Geotextiles are highly resistant to commonly encountered soil chemicals, mildew, insects, and both acidic and alkaline environments. GeoTek™ is non-biodegradable and available in a range of grades to suit various engineering applications.

GeoTek™ non-woven geotextiles are manufactured to the highest international standards and carry ISO 9001:2008 accreditation. As a result, you can be confident that when you use GeoTek™ geotextiles in your construction project, you'll receive consistent, top-quality performance from the first to the last metre of every roll.



FUNCTIONS SERVED BY GEOTEK™ NON-WOVEN GEOTEXTILES



REINFORCEMENT

GeoTek™ geotextiles' strong tensile properties complement soil's limited tensile strength, enhancing overall system strength. Their high strength and low elongation make them ideal for reinforcing embankments, slopes, and retaining walls.



SEPARATION

The placement of GeoTek™ flexible, porous geotextil between dissimilar soil materials preserves the integrity and function of each layer, allowing them to perform effectively without compromising one another.



FILTRATION

GeoTek™ non-woven geotextiles work in harmony with the surrounding soil to enable adequate liquid flow while minimising soil loss across the geotextile plane and preventing pore clogging.



DRAINAGE

The soil-GeoTek™ system balances liquid flow while minimizing soil loss. Its hydraulic properties help maintain structural stability by controlling excess water during and after construction.



PROTECTION

GeoTek™ non-woven geotextiles protect geomembranes and coated materials from damage caused by sharp soils or uneven subgrades. Protection levels increase with geotextile thickness and mass.



EROSION CONTROL

GeoTek™ non-woven geotextiles are ideal for erosion control on slopes, shoreline stabilisation, and riverbank flood protection.

Mechanical Properties	Standard	Units	Stats	GT14A		GT24B		GT34C		GT44D		GT54E		GT64	
Tensile Strength MD/CD	AS3706.2-12	kN/m	Typical	11.0	10.0	15.0	14.0	20.0	18.0	26.0	25.0	35.0	33.0	38.0	36.0
Tear Strength MD/CD	AS3706.3-12	N	Typical	280	270	350	340	460	450	590	560	850	820	1000	950
CBR Burst Strength	AS3706.4-12	N	Typical	1750		2540		3300		4200		5600		6300	
G Rating	Austrroads	-	Typical	1350		2100		2600		3400		5000		5800	
Grab Tensile MD/CD	AS3706.2-12	N	Typical	600	580	950	890	1200	1100	1700	1600	2200	2100	2400	2300
UV Resistance	ASTM D4355	%	Typical	>50 Retained											
Hydraulic Properties															
Flow Rate @ 100mm Head	AS3706.9-12	l/m ² /s	Typical	200		200		180		130		90		50	
Permittivity	AS3706.9-12	s ⁻¹	Typical	2.2		2.2		1.8		1.3		0.9		0.5	
Pore Size O95	AS3706.9-12	micron	Typical	<120		<120		<120		<110		<90		<75	
Product Dimensions															
Roll Length		M		250		150		100		100		75		50	
Roll Width		M		3/6		3/6		3/6		3/6		3/6		3/6	



FILTERMAXX™ GEOTEXTILE

PRODUCT CODE

FM1250
1.2m x 50m

FM2050
2m x 50m

FilterMaxx Geotextile is a practical, non-woven fabric designed for filtration and separation in small-scale applications. It stabilises soil while allowing water to pass through, preventing the intermixing of soil and aggregate layers. Ideal for use behind retaining walls, in subsoil drainage, planter boxes, rooftop gardens, and paved areas, FilterMaxx is supplied in convenient roll sizes for easy handling and installation on-site.



<p>DRAINAGE BEHIND SEGMENTAL RETAINING WALLS</p>	<p>PROTECTION AGAINST PERFORATION OF IMPERVIOUS SHEETING</p>	<p>UNDERGROUND WASTE DISPOSAL AND SOAK AWAY</p>	<p>SEPARATION STABILISATION FilterMaxx™ strengthens the base layer and prevents loss of fines into the prepared subgrade</p>
<p>PAVING FilterMaxx™ ensures correct drainage and prevents risk of substance</p>	<p>GARDEN PATHS FilterMaxx™ prevents the natural soil from mixing with sand or gravel and reduces maintenance</p>	<p>DRAINAGE FilterMaxx™ envelopes the drain trench and improves the efficiency of the drain by holding back the fine particles of soil</p>	<p>ROOF GARDENS FilterMaxx™ separates the drainage course from the top soil and prevents particles entering the outlet system</p>

COREFLUTE SHEET

PRODUCT CODE

CFS24412203B
2440 x 1220 x 3mm, Black

Coreflute Sheets are ideal for landscaping, construction, and waterproofing projects. They provide a protective barrier between waterproof membranes and drainage cells and are commonly used onsite to shield floor coverings. With excellent resistance to impact, water, and chemicals, they offer reliable protection in a range of demanding environments.

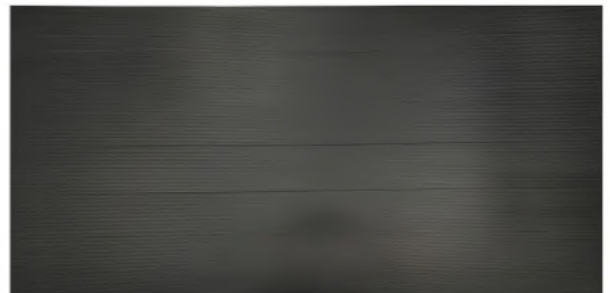

DRAINMAXX™ DRAINAGE CELL

PRODUCT CODE

NDC30
 30mm

NDC52
 52mm

DrainMaxx™ Drainage Cell is a lightweight, three-dimensional geo-composite used for subsurface water management. The polypropylene drainage cell is moulded into a unique profile and may be wrapped in a filtration geotextile, creating a complete void space for water to travel through without obstruction. Its lightweight construction and high compressive strength make it ideal for roof gardens and podium landscaping, retaining walls, sports fields and golf courses, under-slab and foundation drainage, and subsurface drainage for permeable driveways and car parks.



TYPICAL DETAILS OF A ROOFTOP GARDEN

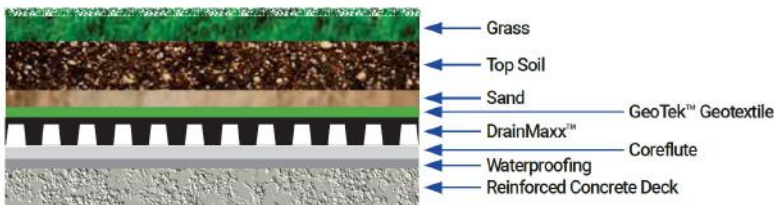

Property	Specifications
Cell (mm x mm)	600 x 500 with integral clips
Cell Depth (mm)	30 or 52mm
Mass (kg/m ²)	2
Volume Void (m ³)	0.027 per m ² of overall cell area (m ²)
Service Temperature (°C)	-10 to +80
Colour	Black
Comprehensive Strength (kPa)	> 1000
Discharge Capacity (1/min/m)	> 360 @ i=0.01
Vertical Flow Rate (1min/m)	> 1000

POLYDRAIN PIPING

StrataGreen stocks a range of Class 400 slotted Polydrain Pipe, ideal for subsurface water transportation. Designed for effective drainage, this piping is a reliable solution for managing excess water beneath the surface in landscaping, construction, and civil applications.

UN-SOCKED

Product Code	Sizing
PLPR6520	65mm x 20m
PLPR10020	100mm x 20m
PLPR100100	100mm x 100m
PLPR16020	160mm x 20m
PLPR16060	160mm x 60m

SOCKED

Product Code	Sizing
PLPR6520S	65mm x 20m
PLPR10020S	100mm x 20m
PLPR100100S	100mm x 100m
PLPR16020S	160mm x 20m
PLPR16060S	160mm x 60m





DRAINMAXX™ SOAKWELL SYSTEM

The DrainMaxx™ Soakwell System is a lightweight, high-strength solution for subsurface stormwater management across all soil types. With up to 90% void storage capacity and a modular design, it's ideal for underground rainwater harvesting, infiltration, and attenuation. Common applications include domestic and commercial systems, grass swales, roadside drainage, retrofitted concrete channels, greywater reuse, and septic leach fields.

PRODUCT SPECIFICATIONS

Dimensions (mm)	
Length	755
Width	400
Height	437
Volume (ltrs)	132
Tanks per m ³	7.5
Weight (kg)	
2 Inner Plates	6.1
3 Inner Plates	6.65
4 Inner Plates	7.3
5 Inner Plates	7.9
Maximum Load (tons/m ²)	
2 Inner Plates	-
3 Inner Plates	23.66 t/m ²
4 Inner Plates	29.76 t/m ²
5 Inner Plates	32.42 t/m ²
Internal Open Area	< 95%
Polymer Type	Polypropylene UV Stabilised
Service Temp	-20°C - 120°C
Chemically inert and not affected by Moulds and Algae	

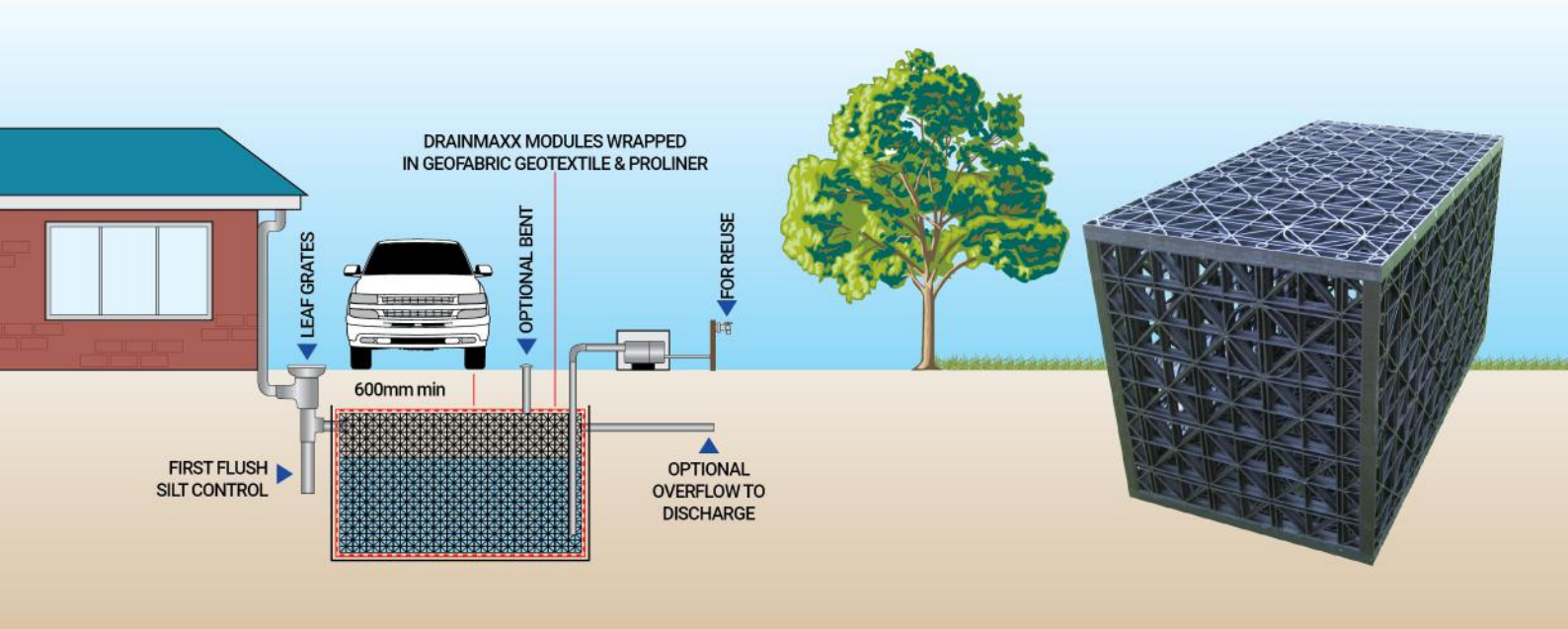

TURFPROTECTA® MATTING

PRODUCT CODE

T49202

550gm/m², 2m x 20m

TurfProtecta® is a lightweight, extruded black plastic mesh designed to reinforce and protect grassed areas exposed to occasional light vehicle or pedestrian traffic. Ideal for car parks, access routes, and aircraft taxiways, it helps prevent rutting, smearing, and surface damage. Supplied in 2m x 20m rolls, TurfProtecta® is perfect for maintaining usability and appearance on grass surfaces prone to wear and tear.

Uses

- Infrequent overflow grass car parks
- Grass access routes
- Pedestrianised grassed areas
- Grass footpaths
- Wheelchair / Disabled (DDA) access routes
- Front Lawn parking

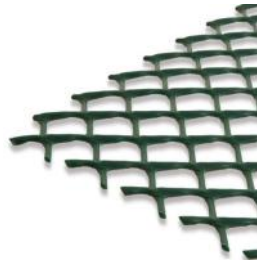

TurfProtecta® is made from 100% recycled high-density polyethylene, UV-stabilised for durability and long-term performance. Simple to install, it is laid over short-cut grass and secured using metal U-pins or plastic pegs. Once installed, grass grows through the mesh apertures, intertwining with the filaments to create a strong, discreetly reinforced surface that helps limit rutting, surface damage, and soil compaction.

For best results, TurfProtecta® should be installed during the growing season, allowing the grass to establish and form a secure interlock with the mesh. Depending on conditions, this can take from a few weeks to a few months. Once fully established, the area can support heavy pedestrian use and occasional vehicle traffic. Grass can be mown, rolled, and fertilised as usual throughout this period.

TurfProtecta® is suitable for both existing lawns and newly landscaped areas. It can be used in permanent or temporary applications such as car parks, access routes, and grassed surfaces prone to becoming muddy or rutted in wet conditions. For new installations, it may be laid on level, well-drained soil, pinned, and covered with topsoil and seed for seamless integration.

BLACK PLASTIC

PRODUCT CODE

BP2100100

2m x 100m / 100um

BP250200

2m x 50m / 200um

BP4100100

2m x 100m / 100um

BP450200

4m x 50m / 200um

This heavy-duty black poly film is ideal for use as a moisture barrier, concrete underlay, floor protection, or anti-dust covering. Commonly used in construction, it's available in 2m or 4m widths and in two thickness grades—100um and 200um.

Durable and easy to install, the film can be laid by overlapping sections and sealing joints with duct tape to ensure an effective barrier. Designed to last, it's a reliable choice for both residential and commercial projects.





TURF CELLS

PRODUCT CODE

TC1000

Developed over 25 years ago in Australia, the concept of reinforced rings to stabilise grassed areas under light to heavy traffic has since gained global acceptance. Grass needs oxygen, moisture, and nutrients to thrive—but when soil becomes compacted, turf can suffocate and die.

Turf Cells is an injection-moulded plastic grid system that forms a strong substructure beneath the turf. It supports vehicle and pedestrian loads while preventing compaction, creating a reinforced, stable, and trafficable grass surface. Engineers, landscapers, and horticulturists appreciate Turf Cells as a durable, cost-effective, and visually appealing alternative to concrete or asphalt in urban environments.

Benefits of Turf Cells

- Grid is flexible - will follow undulations
- Open grid provides over 90% root development area
- Chemical resistance - not affected by water, petrol, vermin, insects or extreme weather
- High impact, UV stabilised, long lasting plastic resists wear and tear

Environmental Benefits

- Increases the green environment
- Reduces the need for hard surfaces
- Erosion Control
- Storm-water run-off reduced
- Waterway contamination reduced 100% Recycled Plastic Retention and Stabilisation of soil surfaces



GRASSINGS - TYPICAL INSTALLATION



Step 1

Excavate soil to required base course depth plus 35mm. Level and compact to engineer's specifications.



Step 2

If required by geotechnical advice, install a geotextile layer beneath the base course for added stability.



Step 3

Add graded blue metal (10–12mm) base course to specified depth. Compact to meet testing requirements. Note: Topsoil must not contain clay or fine material.



Step 4

Assemble TURF CELLS onto the prepared base.



Step 5

Trim around valve boxes, sprinklers, trees, or kerbing using secateurs or cutting pliers. Apply NPK fertiliser or grass starter over sand.



Step 6

Fill cells with clean sharp sand of suitable pH. Use a broom to leave the top edge of each cell exposed. Add 15mm of topsoil for seeding or hydro mulching.



Step 7

For quick establishment, lay roll-on turf. On hot days, wet sand before laying to cool and provide moisture for root contact.



Step 8

Compact lawn with a heavy roller to eliminate air pockets and ensure roots embed in the sand. Water and fertilise as needed. Do not traffic until roots are fully established.

TERRACOTTEM[®]

SMARTSOIL[™]

Combining the organic power of Baileys Soil Improver Plus with the advanced technology of TerraCottem Soil Conditioner, this innovative soil blend is designed to transform poor soils into thriving environments for healthy, resilient trees, turf, gardens and revegetation. Together, they boost soil structure, stimulate root growth, and reduce water use—giving your plantings the ultimate head start and long-term protection.



FEATURES AND ATTRIBUTES

ENHANCED SOIL HEALTH

This powerful blend combines premium organic materials with TerraCottem's volcanic minerals and biostimulants to improve soil structure, boost aeration and drainage, and create a fertile environment that supports healthy root growth from day one.

ENHANCED MICROBIAL ACTIVITY

Enriched with humic acids, organic compounds, and TerraCottem's growth-stimulating agents, this mix promotes microbial activity and encourages robust root development—leading to stronger, more resilient trees and shrubs.

ENHANCED WATER RETENTION

The combined action of organic matter and water-absorbing polymers dramatically increases the soil's water-holding capacity. This means improved moisture availability to plants and up to 50% savings in irrigation water—ideal for sandy soils or drought-prone conditions.

NUTRIENT-RICH & LONG-LASTING

Infused with slow-release NPK fertilisers, trace elements, and biostimulants, this mix not only revitalises nutrient-poor soils but also delivers sustained nutrition to support long-term plant health and higher survival rates in challenging environments.

APPLICATION

SHRUB AND TREE PLANTING

Dig the planting hole twice as large as the plants root ball. Blend the existing soil back fill on a 50:50 ratio with TerraCottem SmartSoil. Fill the base of the hole and position your plant. Fill the remaining area and water well.

NATIVE PLANTING

TerraCottem SmartSoil is suitable for phosphorus sensitive plants when diluted on a 50:50 ratio with existing garden soil. Ensure to blend well.

LAWN AND GARDEN

Use TerraCottem SmartSoil when preparing all soil types for new plantings.

- Light sandy soils - distribute 150mm evenly over the surface. Dig in and water well.
- Medium soils - Distribute 100 to 150mm evenly over the surface. Dig in and water well.
- Heavy soils - Distribute 50 to 100mm evenly over the surface. Dig in and water well.

Lawn Preparation: Prepare the area by removing all weeds, rocks and debris. Add TerraCottem SmartSoil to the topsoil and work into the top 150mm. Level the area and then water well.

Garden and Vegetable bed preparation: Distribute TerraCottem SmartSoil evenly over the planting area, work into the top 150mm and water well.



Trees



Turf



Gardens



Revegetation



StrataGreen
...grow with us

1300 866 367 | sales@stratagreen.com.au | stratagreen.com.au

Currently only available in Western Australia*



SECTION 8

SOIL IMPROVEMENT AND WATERING



NEUTROG GOGO JUICE

PRODUCT CODE

GGJ020
20L

GGJ200
200L

GGJ1000
1,000L

GOGO Juice is teeming with beneficial microbiology and acts as a probiotic for your soil and plants. It combines the catalytic power of billions of beneficial bacteria with the well-documented benefits of kelp, seaweed, fish, humic acid, and manure.



SEAWEED SECRETS EXTRACT 100%

PRODUCT CODE

CSS05
5L

CSS020
20L

CSS200
200L

CSS1000
1,000L

Seaweed Secrets is a pure, concentrated kelp product enhanced with Fulvic Acid to support strong root, flower, and fruit development. Completely organic, it contains a rich mix of minerals and organic compounds that stimulate beneficial soil microbes, improve plant resilience to stress, support new plant establishment, and help protect against frost and heat damage. Suitable for use year-round on all plant types—including natives and camellias—Seaweed Secrets is ideal for revegetation projects and new landscape areas. Dilution rate: 15ml per 9 litres of water.



POWERFEED FISH FERTILISER

PRODUCT CODE

PF005
5L

PF020
20L

PF200
200L

PF1000
1000L

PowerFeed is an organically based fish fertiliser enriched with essential macro nutrients and humic acids. It provides a rich source of nitrogen, potassium, trace elements, and amino acids to enhance growth and improve the colour of flowers, fruit, and foliage. PowerFeed stimulates vital microbial activity, helps break up clay soils, and significantly reduces nutrient leaching in sandy soils. It is 100% soluble and can be applied to both soil and foliage. Application rate: 6–10L per hectare.



SEASOL SEAWEED EXTRACT

PRODUCT CODE

SP20005
5L

SP20006
20L

SP20007
200L

SP20008
1,000L

Seasol Commercial is a highly refined, 100% liquid seaweed plant conditioner that stimulates plant growth and boosts overall health. Sustainably sourced from storm-cast kelp, it contains natural compounds, trace elements, and alginates that enhance root development, improve flowering, and support soil microbial activity. Ideal for reducing transplant shock and increasing resilience to environmental stress. Fully soluble and suitable for soil or foliar application. Dilution rate: 15ml per 9 litres.



SEASOL PLUS FERTILISER

PRODUCT CODE

SPP05
5L

SPP20
20L

SPP200
200L

SPP1000
1,000L

Seasol Plus+ is a powerful all-in-one soil conditioner and natural growth stimulant. It combines Seasol seaweed extract with added fish, humic and fulvic acids to enhance root development, stimulate plant growth, and improve soil health. Ideal for boosting plant establishment, reducing transplant shock, and increasing resistance to stress, Seasol Plus+ supports nutrient uptake and promotes strong, healthy growth in all plant types. Contains virtually no nitrogen or phosphorus, making it safe for use year-round.





SEASOL PLANTING GEL

PRODUCT CODE

EPG10
10kg

This cutting-edge technology delivers a scientifically formulated blend of Seasol, PowerFish, and water directly into the root zone of plants or turf at the critical time of planting. Developed by Seasol International, the special gel contains a pre-injected mix of water and nutrients that is slowly released into the root zone. This process stimulates root growth, reduces transplant shock, and supports strong plant establishment. With a working life of up to five years, the gel continually recharges itself—providing a sustained supply of water and soluble nutrients to plants and turf.



TURFMASTA FERTILISER & SOIL CONDITIONER

PRODUCT CODE

TM005 5L **TM020** 20L **TM200** 200L **TM1000** 1000L

A premium blend of kelp, fish, and humate designed for turf. Stimulates soil microbes, enhances soil health, and provides a gentle nitrogen boost. Ideal for new grass establishment and maintaining strong, healthy turf growth year-round.

TREEMASTA

PRODUCT CODE

TRM005 5L **TRM020** 20L **TRM200** 200L **TRM1000** 1000L

TREEMASTA is a specialised blend of ENVIROSOAK Soil Wetter, kelp, fish, humate, and nitrogen, developed for use as a tree-watering additive. It stimulates a wide range of beneficial soil microbes to enhance soil function and includes a small amount of nitrogen to support healthy plant and tree growth. TREEMASTA is especially valuable when planting new trees and for boosting the growth and productivity of established trees.



BIOPRIME

PRODUCT CODE

BIOPR25
20L

Bioprime is a unique soil priming agent that works by enhancing soil microbiology. It contains a broad spectrum of signalling molecules that, even in small amounts, stimulate shifts in microbial diversity. When applied to soil, Bioprime promotes the development of beneficial microbes and supports a healthier, more balanced soil ecosystem.

BIOPRIME DICOT

PRODUCT CODE

BIOPRDI25
20L

Bioprime Dicot is specifically formulated for non-grass crops to deliver the same root-enhancing and disease-prevention benefits as standard Bioprime. Dicots refer to broadleaf crops in rotation, such as canola, lupins, peas, and clovers. Unlike cereals, these plants do not form mycorrhizal associations with soil fungi, making Bioprime Dicot a valuable tool for supporting soil health and plant development in these species.





BIOPRIME TRACE

PRODUCT CODE

BIOPRTR25
20L

Bioprime Trace is a new and innovative solution for delivering fully chelated trace elements to your crop. It takes advantage of Bioprime's rich content of organic acids, which act as ideal chelators—preventing trace elements from binding to soil particles and ensuring they remain available for plant uptake.



HYDROFORCE INJECT SOIL SURFACTANT

PRODUCT CODE

HFI020
5L

HFI200
200L

HFI1000
1,000L

HydroForce Inject is a high-quality thatch and soil penetrant surfactant blend, specifically designed to quickly and efficiently move water away from foliage and thatch into the growing medium. It is economical and ideal for injection into irrigation systems or application via boom sprayer for large-scale use.

ENVIROSOAK LIQUID SOIL WETTER

PRODUCT CODE

ELSW01
1L

ELSW05
5L

ELSW20
20L

ELSW200
200L

ELSW1000
1000L

EnviroSoak is an effective long-term soil wetting agent, ideal for treating and preventing hydrophobic (water-repellent) soils in lawns, garden beds, and around trees. It evenly re-wets the soil, prevents water run-off, and improves water penetration—all while maintaining very low phytotoxicity. EnviroSoak can also be safely added to water containing any of Manutec's soluble fertilisers to ensure rich, even fertiliser penetration into the soil. One litre of EnviroSoak Concentrate treats 200–400 square metres.



AQUALOCK WATER RETAINER

PRODUCT CODE

AQL001
1L

AQL005
5L

AQL020
20L

AQL200
200L

AQL1000
1,000L

Aqualock Retain is more than just a soil wetting agent—it's a radically new technology designed to improve how plants access and use soil moisture. Aqualock contains polymers that reduce soil moisture evaporation by absorbing and storing water as microscopic droplets on root hairs, root tips, and soil particles. This significantly enhances the utilisation of irrigation water, light rainfall, dew, and humidity at the root zone. With greater access to soil moisture, plants experience significantly less moisture stress. On average, areas treated with Aqualock take twice as long to reach wilt point compared to those treated with water alone. One litre of Aqualock treats up to 2,000 square metres.



ECO-WET SOIL WETTER

PRODUCT CODE

EGEW5
5L

EGEW20
20L

Eco-Wet® is a unique soil wetter designed for rapid water penetration and long-lasting moisture retention—even in the sandiest soils. Unlike most soil wetters that have only one or two of these qualities, Eco-Wet® combines all three. It spreads water evenly through the soil profile like ink on blotting paper, making it ideal for irrigation, boom spraying, in-furrow, and tanker applications.





ECO-FULVATE

PRODUCT CODE

EGEF20
20L

Fulvic Acid is renowned for its natural chelating properties, commonly used as an additive to foliar fertilisers and herbicides like glyphosate to improve leaf nutrient uptake. Eco-Fulvate, a concentrated humate-derived polymer developed in Australia, enhances fertiliser effectiveness by improving nutrient compatibility and uptake while stimulating soil biological activity. Fully soluble, it is ideal for use in spray and fertigation programs, helping boost plant health and nutrient efficiency.



ECO-VITAL

PRODUCT CODE

EGEV5
5L

EGEV20
20L



Eco-Vital is a biological trace element product rich in natural nutrients, including nitrogen, phosphorus, potassium, calcium, over 60 trace and rare-earth elements, plus seaweed and fish extracts. Its naturally chelated nutrients are up to 90% more efficiently absorbed by plants, resulting in lower application rates and faster uptake. Plants treated with Eco-Vital show balanced nutrition, consistent growth, strong cell walls, and excellent cell density.

ECO-HUMATE

PRODUCT CODE

EGEH5
5L

EGEH20
20L

Eco-Humate is a concentrated soil conditioner ideal for treating water-repellent soils and enhancing the effectiveness of your fertiliser program. This liquid humic acid improves soil cation exchange capacity (CEC), increases nutrient availability, and reduces nutrient leaching.



ECO-GROWTH FISH FERTILISER

PRODUCT CODE

EGLFF20
20L



Eco Growth's Liquid Fish is an organically certified, cold-pressed fish hydrolysate produced in Australia. Its cold digestion process preserves the fish's quality and nutritional integrity, retaining key enzymes, vitamins, and amino acids in their purest form to support healthy, productive, and resilient plants and soils.

ASTRO 120ME TURF GROWTH REGULATOR

PRODUCT CODE

A120MEGR01
1L

A120MEGR10
10L

Astro 120 ME Growth Regulator is an efficient and versatile turf management tool that maximizes turf quality, helps prevent stress, and optimizes resource use. It regulates leaf and stem growth of grass species and supports overall turf management, following the Directions for Use.





REGULATE PLANT GROWTH REGULATOR

PRODUCT CODE

RPGR25

2.5L

ProForce Regulate is a powerful plant growth regulator formulated to reduce vegetative growth in a wide range of ornamental hedges and groundcovers. Containing 200g/L Paclobutrazol in a suspension concentrate, it helps decrease pruning frequency, improve hedge appearance, and minimise green waste—making it an essential tool for landscapers, councils, and property managers.



SEAMUNGUS ORGANIC PELLETS

PRODUCT CODE

SEA020

20kg

Seamungus is a soil and plant conditioner, manufactured by combining the very best of composted raw materials - seaweed, fish, humic acid and manure. It will help increase plants resistance to pests and disease, stimulate healthy growth and most importantly, generally improve the well being of your soils and plants. Very low odour, making it ideal for schools and other public places. Available in 20kg bags.



NEUTROG BUSH TUCKER

PRODUCT CODE

NBT020

20kg

Bush Tucker is a native plant fertiliser developed by Neutrog in collaboration with native plant expert Angus Stewart and soil scientist Simon Leake. Recommended by the Australian Plants Society of Victoria, it's specially formulated to meet the needs of all Australian natives, including phosphorus-sensitive varieties like grevilleas, banksias, and proteas. Its unique formulation includes trace elements that bind excess phosphorus and beneficial microbes that enhance nutrient uptake, promote root growth, and stimulate natural soil processes.

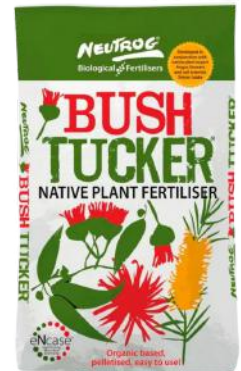

NEUTROG BOUNCE BACK

PRODUCT CODE

NBB020

20kg

Premium all purpose organic fertiliser for all your garden plants. Bounce Back is 100% organic and natural making it totally environmentally friendly and safe to use. Bounce Back is in pelletised form which gives it a longer term slow release making it ideal for regular garden maintenance. Available in 20kg bags.



NEUTROG BLADE RUNNER

PRODUCT CODE

NBR020

20kg

Premium 100% slow release organic lawn fertiliser ideal for all lawns. Being 100% natural it is environmentally friendly and safe and easy to use. Blade Runner is in crumble form, making it ideal for applying to established turf areas. The crumble is fine enough to be washed into the rootzone with a normal watering event, thus preventing being picked up when mowing the turf.





NEUTROG UPSURGE LAWN FERTILISER

PRODUCT CODE

NUPC020

20kg

Boost your lawn's health and appearance with Neutrog Upsurge – a premium, Australian-made lawn fertiliser formulated with an organic base and boosted with essential nutrients for long-lasting results. Upsurge delivers a balanced NPK of 8:1:4, plus a full suite of secondary nutrients and micronutrients in a natural, slow-release form. The crumble formulation is ideal for established turf areas—fine enough to wash down into the root zone during regular watering and less likely to be picked up during mowing.



SUDDEN IMPACT FOR ROSES

PRODUCT CODE

SIFR020

20kg

Sudden Impact for Roses was developed in collaboration with the rose societies of Australia and has become the country's leading rose fertiliser. But it's not just for roses—this premium blend is ideal for a wide variety of flowering and fruiting plants, delivering impressive blooms, healthy foliage, and robust growth.

GYGANIC FERTILISER

PRODUCT CODE

GYGAN20

20kg

Gyganic is a powerful, biologically enhanced fertiliser specifically designed to improve the size, uniformity, and quality of fruit, vegetable, and flower production. Ideal for commercial growers and home gardeners alike, this pelleted organic-based fertiliser delivers a balanced nutrient supply for optimal plant performance



BLACK MAGIC ROSE FERTILISER

PRODUCT CODE

BM020

20kg

Introducing Black Magic Rose Fertiliser - the secret to achieving luscious green foliage and vibrant blooms on your roses. With a 4-6 weeks application, this powerful formula ensures your roses thrive and flourish. It enhances the growth of your roses and acts as a versatile fertiliser for all your flowering and fruiting plants in the garden. Get ready to witness the stunning transformation of your garden with Black Magic Rose Fertiliser.



POLYCOTE PLUS CONTROLLED RELEASE FERTILISER

PolyCote Plus is a polymer coated controlled release compound fertiliser with added trace elements, and the patented Troforte microbiological technology. The coating of bio-degradable polymer is tough & flexible, totally dependable under conditions of temperature stress and osmotic pressure.

Key Benefits

- Consistent nutrient release across varying temperatures
- Balanced delivery of nitrogen, phosphorus, potassium, and trace elements
- Includes up to 24 strains of beneficial Australian soil microbes to enhance soil health, nutrient uptake, and overall plant performance

GENERAL PURPOSE LANDSCAPE BLEND 20KG

PRODUCT CODE

PPGP03

3 Month Release

PPGP06

6 Month Release

PPGP09

9 Month Release

PPGP12

12 Month Release

Macro Elements		Micro Elements	
Total Nitrogen (N)	16.30%w/w	Sulphur (S)	4.90%w/w
as Urea	8.60%w/w	Calcium (Ca)	3.04%w/w
as Ammonia	4.37%w/w	Silicon (Si)	1.30%w/w
as Nitrate	3.32%w/w	Magnesium (Mg)	1.10%w/w
		Iron (Fe)	1.08%w/w
		Manganese (Mn)	1500 ppm
Total Phosphorous (P)	3.41%w/w	Copper (Cu)	200 ppm
Water Soluble	3.10%w/w	Zinc (Zn)	200 ppm
Citrate Soluble	0.31%w/w	Boron (B)	45 ppm
Total Potassium (K) as Sulphate	8.82%w/w	Nickel (Ni)	6 ppm
		Molybdenum (Mo)	5 ppm



NATIVE LANDSCAPE BLEND 20KG

PRODUCT CODE

PPNF03

3 Month Release

PPNF06

6 Month Release

PPNF09

9 Month Release

PPNF12

12 Month Release

Macro Elements		Micro Elements	
Total Nitrogen (N)	17.7%w/w	Sulphur (S)	4.90%w/w
as Urea	8.60%w/w	Calcium (Ca)	3.04%w/w
as Ammonia	5.1%w/w	Silicon (Si)	1.30%w/w
as Nitrate	4.0%w/w	Magnesium (Mg)	1.10%w/w
		Iron (Fe)	1.08%w/w
		Manganese (Mn)	1500 ppm
Total Phosphorous (P)	1.28%w/w	Copper (Cu)	200 ppm
Water Soluble	1.17%w/w	Zinc (Zn)	200 ppm
Citrate Soluble	0.11%w/w	Boron (B)	45 ppm
Total Potassium (K) as Sulphate	10.57%w/w	Nickel (Ni)	6 ppm
		Molybdenum (Mo)	5 ppm



MINI PRILL TURF 20 KG

PRODUCT CODE

PTFM03

3 - 4 Month Release

Macro Elements		Micro Elements	
Total Nitrogen (N)	18.2%w/w	Sulphur (S)	1.54%w/w
as Urea	2.53%w/w	Calcium (Ca)	5.76%w/w
as Ureaform	14.30%w/w	Silicon (Si)	8.16%w/w
as Nitrate	1.37%w/w	Magnesium (Mg)	1.10%w/w
		Iron (Fe)	3.07%w/w
		Manganese (Mn)	4100 ppm
Total Phosphorous (P)	1.00%w/w	Copper (Cu)	480 ppm
Water Soluble	1.00%w/w	Zinc (Zn)	500 ppm
Total Potassium (K) as Sulphate	4.4%w/w	Boron (B)	100 ppm
		Nickel (Ni)	38 ppm
		Molybdenum (Mo)	2 ppm





MANUTEC HYDRANGEA BLUEING AGENT

PRODUCT CODE

MT05010

500g

Manutec Hydrangea Blueing Agent is a water-soluble blend designed to maintain the ideal nutrient levels in soil to promote and sustain vibrant blue sepals on hydrangeas. Supplied in a 500g pack, it provides a balanced formulation with an NPK ratio of 23:1.9:19.5, ensuring healthy growth and colour enhancement.



MANUTEC HYDRANGEA PINKING AGENT

PRODUCT CODE

MT05011

500g

Manutec Hydrangea Pinking Agent is a water-soluble blend formulated to maintain the ideal soil nutrient levels needed to produce and preserve pink sepals on hydrangeas. Available in 500g packs, it features an NPK ratio of 21:3:12 to support healthy plant growth and vibrant colour.

MANUTEC ACIDIC PLANT FOOD

PRODUCT CODE

MT05078

500g

Manutec Acidic Plant Food is a premium water-soluble fertiliser formulated specifically for acid-loving plants such as Azaleas, Camellias, Rhododendrons, Gardenias, and Conifers. With a balanced nutrient ratio of NPK 15:4.5:12.5, it promotes healthy growth, vibrant blooms, and lush foliage.



MANUTEC TOMATO GRANULES

PRODUCT CODE

MT02248

1kg

Manutec Tomato Granules is a slow-release granular fertiliser specifically formulated to support healthy growth and enhance the yield, flavour, and quality of tomatoes. Supplied in 1kg bottles, it has an NPK ratio of 10:2:9 for balanced nutrition throughout the growing season.

MANUTEC TOMATO MAGIC

PRODUCT CODE

MT06713

1kg

Manutec Tomato Magic is a water-soluble fertiliser specially designed for tomatoes, capsicums, eggplants, and related vegetables. With a high potassium content and added calcium, it supports strong plant growth, enhances fruit set, and helps prevent blossom-end rot. Its balanced 12:8:20 NPK ratio promotes healthy flowering and improved yields.

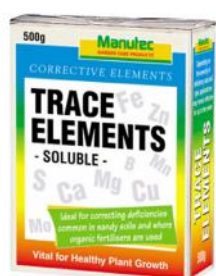

MANUTEC TRACE ELEMENTS

PRODUCT CODE

MT05006

500g

Manutec Trace Elements is a balanced, water-soluble blend of essential trace elements designed to correct multiple micronutrient deficiencies in one easy application. Ideal for maintaining healthy soil and plant growth, it's suitable for use across a wide range of plants. Available in 500g packs.



MANUTEC AFRICAN VIOLET FOOD

PRODUCT CODE

MT03503
300g

Manutec African Violet Food is a premium, water-soluble fertiliser specially formulated to meet the unique needs of African Violets. With its balanced nutrient blend of NPK 18:3:13, it promotes vigorous leaf growth and encourages prolific, vibrant flowering, ensuring your plants remain healthy and stunning year-round.



MANUTEC ORCHID FOOD

PRODUCT CODE

MT05002
500g

Manutec Orchid Food is a water-soluble fertiliser formulated with a balanced blend of nutrients ideal for orchids. Suitable for year-round use, it supports healthy growth, vibrant blooms, and strong root development. Available in 500g packs. NPK 17.7:7.9:16.

MANUTEC ORCHID BLOOM BOOSTER

PRODUCT CODE

MT05008
500g

Orchid Bloom Booster is a specialised fertiliser designed to enhance the production of vibrant and abundant orchid blooms. Formulated with essential major and minor nutrients, it features a high potassium content that promotes larger, more colourful flowers, as well as an increased number of spikes and blooms. NPK 17.7:7.9:16.



MANUTEC FOLIAGE FEEDER

PRODUCT CODE

MT05005
500g

Manutec Foliage Feeder is rich in nitrogen and essential nutrients that promote lush, healthy green growth in foliage plants. It's also ideal for leafy vegetables and herbs, supporting strong, vigorous development. Its water-soluble formula ensures quick nutrient absorption for fast and effective feeding.

MANUTEC FRUIT & CITRUS FERTILISER

PRODUCT CODE

MT05007 | **MBP0252**
500g | 2.5kg

Manutec Fruit & Citrus Fertiliser is a granular fertiliser that has been specifically blended to maintain healthy foliage and enhance the size, taste and quality of fruit on fruit and citrus trees. NPK 11:2:13



MANUTEC HYDROPONIC NUTRIENT

PRODUCT CODE

MT05009
500g

Manutec Hydroponic Nutrient is a water-soluble fertiliser that provides all essential nutrients, making it ideal for all hydroponic cultures. It is available in 500g with an NPK ratio of 7.6:3.1:18.2.



MANUTEC BORON

PRODUCT CODE

MT00544B
500g

Boron deficiency causes 'Brown Heart' in fruits and vegetables and results in breakdown of tissues. Boron deficiencies are most common in alkaline soils. Manutec Boron is water soluble and comes in 500g packs.



MANUTEC SULPHUR

PRODUCT CODE

MT00555B | **MBP0308**
500g | 3kg

Manutec Sulphur is water soluble and is an efficient acidifying agent to reduce the pH of alkaline soils. Sulphur is an important nutrient for acid loving plants. Manutec Sulphur is available in 500g & 3kg packs.

MANUTEC MANGANESE SULPHATE

PRODUCT CODE

MT00599B
500g

Manutec Manganese Sulphate is water soluble and is used for correcting manganese deficiency in plants which causes blotchy yellowing between the veins of young leaves. Manutec Manganese Sulphate is available in 500g packs.



MANUTEC WETTABLE SULPHUR

PRODUCT CODE

MT00557
500g

Manutec Wettable Sulphur is a soluble form of elemental sulphur which is easy to mix and spray and effectively controls powdery mildew, scab, rust and mites. Manutec Wettable Sulphur is available in 500g packs.

MANUTEC MAGNESIUM SULPHATE

PRODUCT CODE

MT00588
500g

Manutec Magnesium Sulphate is water soluble and supplies magnesium to correct deficiencies. Also commonly known as Epsom Salts. Manutec Magnesium Sulphate is available in 500g packs.

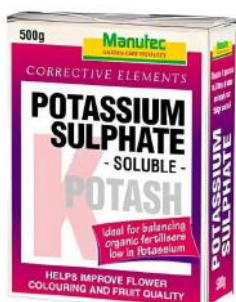

MANUTEC POTASSIUM SULPHATE

PRODUCT CODE

MT00500
500g

Manutec Potassium Sulphate is a highly soluble and cost-effective source of potassium, an essential nutrient for promoting flowering, fruiting, and overall plant resistance. Potassium plays a vital role in plant health by regulating water movement between cells and strengthening cell walls, which enhances disease resistance and supports vibrant growth.



MANUTEC SULPHATE OF AMMONIA

PRODUCT CODE

MBP0265
2.5kg

Manutec Sulphate of Ammonia is a quick response and economical form of nitrogen fertiliser. Manutec Sulphate of Ammonia promotes lush green growth in all plants, leaf crop vegetables and lawns. Available in 2.5kg bags.



MANUTEC VERMICULITE

PRODUCT CODE

MBP5950 | **MBP1295**
5L | 12L



Manutec Vermiculite is a premium, lightweight soil conditioner that enhances drainage, aeration, and moisture retention in potting mixes, propagation media, and hydroponic systems. Available in 5L and 12L packs, it is ideal for home gardeners, nurseries, and landscapers seeking to improve soil structure and promote healthy root development without adding weight or compaction. Vermiculite creates a balanced growing environment, supporting vigorous plant growth across a variety of applications.

MANUTEC SULPHATE OF POTASH

PRODUCT CODE

MBP1104 | **MBP0266**
1kg | 2.5kg

Manutec Sulphate of Potash is a highly soluble, high-analysis source of potassium, essential for healthy plant growth at all stages. Potassium plays a critical role in helping plants resist environmental stresses such as drought, frost, extreme temperatures, pests, and diseases. It is especially important during the reproductive stages of growth – including flowering and fruiting – where it enhances the size, color, and quantity of flowers and fruits.



MANUTEC MAGNESIUM SULPHATE

PRODUCT CODE

MBP1105
1kg



Manutec Magnesium Sulphate, also known as Epsom Salts, is a highly soluble source of magnesium that helps correct deficiencies in plants. It promotes healthy growth, improves leaf colour, and supports overall plant vitality. Ideal for use in gardens, potting mixes, or as a foliar spray.

MANUTEC MOSS KILLER LAWN FOOD

PRODUCT CODE

MBP0264 | **MBP0264**
2.5kg | 5kg

Manutec Moss Killer & Lawn Food is a dual-action formula that controls moss while feeding your lawn in a single application. It encourages healthy grass growth to quickly fill in bare patches left by dead moss, helping restore a lush, green lawn. Available in 2.5kg and 5kg bags.





MANUTEC UREA

PRODUCT CODE

MBP0200

2kg

Manutec Urea is a high-nitrogen, fast-acting, and fully water-soluble fertiliser that promotes lush green growth in all plants, including leafy vegetables, lawns, and foliage plants. Ideal for giving plants a quick nitrogen boost, it supports vigorous growth and healthy green foliage. Available in 2kg bags.



MANUTEC GARDEN COMPLETE

PRODUCT CODE

MBP0250

2.5kg

Manutec Garden Complete is a granular fertiliser formulated for general garden use. It delivers balanced nutrients to support healthy foliage, vibrant blooms, and overall plant vitality. Regular application helps maintain strong, thriving plants across a wide variety of garden types.

MANUTEC ROSE FERTILISER

PRODUCT CODE

MBP0251

2.5kg

Manutec Rose Fertiliser is a granular fertiliser that has been specifically blended to maintain healthy foliage and enhance the size, colour and quantity of blooms on roses and other flowering plants. NPK 12:1.9:10



MANUTEC AZALEA & CAMELLIA FERTILISER

PRODUCT CODE

MBP0254

2.5kg

Manutec Azalea & Camellia Fertiliser is a granular fertiliser that has been specifically formulated to maintain healthy foliage and root growth on all varieties of acid-loving plants. NPK 11:1.94:12

MANUTEC LAWN FERTILISER

PRODUCT CODE

MBP0255

2.5kg

Manutec Lawn Fertiliser is a granular fertiliser that supplies all the essential nutrients including a broad range of trace elements required to maintain a healthy lawn with strong root growth. Manutec Lawn Fertiliser is available in 2.5kg. NPK 16:1:5





BAILEYS POTTING MIX

PRODUCT CODE

F8064
25L

Baileys Potting Mix is a premium, professional-grade blend perfected over many years to provide the ideal growing environment for a wide range of plants. It delivers complete nutrition, so all you need to do is pot and water—ensuring consistent, healthy plant growth with minimal effort.



BAILEYS SOIL IMPROVER PLUS

PRODUCT CODE

F8423
25L

Baileys Soil Improver is a mature organic compost formulated to enhance soil structure and boost fertility. It adds essential organic carbon to support microbial activity while improving the soil's ability to retain water and nutrients. Apply at 50–150L per m², depending on soil density.

BAILEYS BLOOD & BONE

PRODUCT CODE

F2009
20kg

Baileys Blood & Bone Mix is an organic-based plant food that supports all-round garden health by improving soil structure. With a mild, slow-release action, it's suitable for most gardening applications and can be used alone or alongside higher analysis fertilisers. Its gentle formulation makes it safe and effective for regular use.



GROWSAFE GARDENER FERTILISER

PRODUCT CODE

GAPF25
20kg

Baileys Soil Improver is a mature organic compost formulated to enhance soil structure and boost fertility. It adds essential organic carbon to support microbial activity while improving the soil's ability to retain water and nutrients. Apply at 50–150L per m², depending on soil density.

GROWSAFE TURF + P

PRODUCT CODE

GTF25
20kg

Grow safe Turf Fertiliser is specially blended for the planting and maintenance of turf, delivering high performance results for healthier, more resilient lawns. With over 60 minerals and 25 beneficial microbe species, it improves nutrient efficiency, restores soil health, and supports water conservation. Featuring an NPK ratio of 9.5-5-5, it is applied at 30–40g/m² for planting and 15–25g/m² for ongoing maintenance.





GROWSAFE TURF + N

PRODUCT CODE

GASTF25

20kg

Growsafe High-Traffic Turf Fertiliser is specially formulated for maintaining turf in heavily used areas, promoting faster recovery from wear and tear. Its low phosphorus content makes it suitable for sensitive sites. Packed with over 60 minerals and 25 microbe species, this high-performance fertiliser enhances nutrient efficiency, restores soil health, and supports water conservation. With an NPK ratio of 15-1-5.7, it is applied at 15–25g/m² (150–250 kg/ha).



GROWSAFE TURF + N FERTILISER WITH ENVIROSOAK SOIL WETTER

PRODUCT CODE

GASEGW25

20kg

Grow Safe Turf Plus N Fertiliser, pre-blended with EnviroSoak Granular Soil Wetter, offers a convenient solution for healthier, more resilient turf while reducing water use. With over 60 minerals and 25 beneficial microbes, it improves nutrient efficiency and soil health. EnviroSoak helps treat and prevent water-repellent soils, enhancing water penetration and preventing runoff. This single-application product has an NPK ratio of 10.5:1.7:4.7 and an application rate of 30-40g/m². Available in 20kg bags, with bulk options.

GROWSAFE SPREADABLE SOIL MICROBES

PRODUCT CODE

GBSM025

20kg

Grow Safe® Spreadable Microbes are a concentrated, soil-probiotic blend of beneficial bacteria, fungi, and trace elements designed to improve soil health, root development, and nutrient access across all plant and soil types. This easy-to-apply granular formula supports plant germination, growth, and resilience—making it ideal for commercial growers, landscapers, and home gardeners alike.



GROWSAFE PREMIUM SOIL MICROBES

PRODUCT CODE

AMFPH01

1kg

Grow Safe Microbes is a balanced blend of beneficial soil microorganisms that enhance nutrient availability and uptake by plants. This mix includes key species like nitrogen-fixing Azotobacter, soil-conditioning Bacilli, nutrient-assisting Mycorrhizae, protective Pseudomonas, nitrogen-fixing Rhizobium, and health-boosting Trichoderma. These microbes play vital roles in soil fertility, improving water efficiency and overall plant health. Supplied as a wettable powder, Grow Safe Microbes can be applied as a liquid foliar spray to support cropping, pasture, and horticultural operations.



ECOGROWTH BLUE

PRODUCT CODE

EGEPB25
20kg

Eco Growth® Blue is a complete rock-mineral based fertiliser formulated for general-purpose use across a wide variety of landscape and horticultural applications. Enriched with Eco Advance® Premium Biology, including mycorrhizal fungi and nitrogen-fixing bacteria, it promotes strong root development, vigorous shoot growth, and improved fruit quality. Its natural composition delivers balanced NPK along with essential calcium magnesium, and trace elements for healthier, more resilient plants.



ECOGROWTH PURPLE

PRODUCT CODE

EGEPP25
20kg

Eco Growth® Purple is a versatile NPK fertiliser enriched with trace elements to support ongoing plant nutrition across a broad range of applications, including vegetables, fruits, vines, flowers, turf, and ornamentals. This advanced blend includes potassium and a granulated silicate mineral complex, enhanced with Eco Advance® Premium Biology—featuring mycorrhizal fungi and nitrogen-fixing bacteria—to boost nutrient uptake, root development, and overall plant health.

ECOGROWTH RED

PRODUCT CODE

EGEPR25
20kg

Eco Growth® Red is a specialised mineral NPK fertiliser formulated with a complex blend of nutrients, including Potassium Sulphate and granulated Soft Rock Phosphate. Enhanced with Eco Advance® Premium Biology—featuring Mycorrhizal fungi and phosphorus-solubilising microbes like Bacillus megaterium—it supports strong root development, improves phosphorus availability, and promotes healthy, resilient plant growth across a variety of crops and soil types.



ECOGROWTH ORANGE

PRODUCT CODE

EGEPO25
20kg

Eco-Prime® Orange is a premium biologically enhanced NPK fertiliser specially formulated to meet the nutritional demands of high-yield fruiting trees, including citrus. With a carefully balanced blend of macro and micronutrients, Eco-Prime® Orange promotes strong tree structure, optimal fruit set, and improved fruit size and quality — even in challenging growing conditions.

ECO GROWTH EMERALD

PRODUCT CODE

WS10720
20kg

WS11730
25kg - Mini Prill

Eco Growth® Emerald Lawn Fertiliser is a complete rock mineral NPK fertiliser enriched with beneficial microbes to promote healthy, resilient turf. Formulated to support balanced nutrition and encourage strong root growth, it enhances lawn appearance and performance, making it ideal for both residential and commercial lawn applications.





ENVIROSOAK GRANULAR SOIL WETTER

PRODUCT CODE

EGSW
20kg

EnviroSoak Granular Soil Wetter is a highly concentrated, commercial grade product ideal for the treatment of large areas of hydrophobic (water repellent) soil such as ovals and parklands. It has good soil penetration properties and excellent longevity, lasting for up to 12 weeks in the soil.



EARTHCARE WATER CRYSTALS

PRODUCT CODE

PD280
25kg

Water Crystals are super absorbent polymers that help improve soil moisture retention by absorbing excess water and gradually releasing it back to plants during dry periods. Capable of storing up to 500 times their weight in water, they are ideal for transplanting trees and shrubs, reducing transplant shock and supporting root establishment. Biodegradable and environmentally safe, Water Crystals come in 20kg bags and are applied at 1.5g per litre of backfill soil or 1g per 50mm tube stock.

IRON CHELATE

PRODUCT CODE

FE25
20kg

Iron Chelate is a highly effective and safe micronutrient that supports healthy plant growth by aiding in chlorophyll production and nitrate utilisation. It helps correct iron deficiencies that can lead to yellowing leaves, stunted growth, and poor flower or fruit development. More efficient than inorganic iron sulphate, Iron Chelate is highly soluble, promotes quick root-to-leaf uptake, and leaves less salt residue in the soil. Supplied in a 20kg carton, it offers excellent protection against nutrient interference in the soil.



WATHEROO BENTONITE CLAY

PRODUCT CODE

WB020
20kg

WB1000
1,000kg



Watheroo Calcium Bentonite Clay is a popular natural clay product ideal for improving soil health, productivity, and water efficiency in commercial landscapes. With no added chemicals, Bentonite Clay enhances sandy soils by improving wettability, increasing water holding capacity, boosting nutrient retention, enhancing soil structure, and supporting biological activity. Application rate is between 3–5kg per square metre.

STOLLER FOLI-ZYME

PRODUCT CODE

SFZ020
20L

SFZ200
200L

SFZ1000
1,000L

Stoller Foli-Zyme is a complete foliar fertiliser formulated to support balanced plant growth and assist in stress recovery caused by factors such as extreme temperatures. Ideal for use on crops, turf, and ornamental plants, it helps restore healthy growth and improve resilience. Typically applied at 5L per hectare, diluted at a rate of 500ml per 200L of water.





STOLLER AQUA-CAL

PRODUCT CODE

SAC020
20L

SAC200
200L

SAC1000
1,000L

A highly available calcium source designed to displace salt and enable a plant to survive salty soils or salty irrigation water. Applied through the irrigation to the soil, Aqua-Cal will release salt and improve drainage. Typical application rate is 25 litres of concentrate per hectare. Available in 20 litre, 200 litre and 1,000 litre containers.



STOLLER BIO-FORGE

PRODUCT CODE

SBF010
10L

Stoller Bio-Forge is a powerful plant stress management solution formulated to help crops recover and thrive following extreme environmental stress. Whether it's drought, heat, frost, waterlogging, or herbicide damage, Bio-Forge supports plants in restoring normal growth and productivity by reducing the build-up of excess ethylene—a stress hormone that can suppress plant development.

STOLLER ROOTFEED

PRODUCT CODE

SRF020
20L

SRF200
200L

SRF1000
1,000L

A slow-release amine nitrogen fertiliser enriched with calcium and magnesium for regular application via irrigation. Supports consistent root growth, uniform flowering, improved fruit quality and higher yields. Apply at 10–20 L/ha. Available in 20 L, 200 L and 1,000 L.



STOLLER FOLIAR PLUS

PRODUCT CODE

SFP020
20L

SFP200
200L

SFP1000
1,000L

Foliar Plus is a balanced NPK fertiliser designed for both foliar and soil applications, containing a full mix of primary, secondary, and micronutrients. For a complete foliar spray, it is typically combined with Stoller's SETT or SETT Enhanced. The usual dilution rate is 500ml of concentrate per 200 litres of water, with an application rate of 5 litres per hectare.



STOLLER CHELATE RANGE

These individual nutrient products feature single elements in chelated form, using Stoller's proprietary phenolic chelating agent for enhanced absorption. Suitable for both foliar and soil application, they deliver nutrients efficiently for a quick plant response. The range includes Zinc, Manganese, Magnesium, Copper, Iron, and Calcium. Typical dilution is 200ml of concentrate per 200 litres of water, with an application rate of 2 litres per hectare. Please see our pricelist for the full range.



Product Code	Product	Size (L)
SCA020	Stoller Calcium Chelate	20
SCA200	Stoller Calcium Chelate	200
SCA1000	Stoller Calcium Chelate	1,000
SCC020	Stoller Copper Chelate	20
SCC200	Stoller Copper Chelate	200
SCC1000	Stoller Copper Chelate	1,000
SIC020	Stoller Iron Chelate	20
SIC200	Stoller Iron Chelate	200
SIC1000	Stoller Iron Chelate	1,000

Product Code	Product	Size (L)
SZC020	Stoller Zinc Chelate	20
SZC200	Stoller Zinc Chelate	200
SZC1000	Stoller Zinc Chelate	1,000
SMC020	Stoller Magnesium Chelate	20
SMC200	Stoller Magnesium Chelate	200
SMC1000	Stoller Magnesium Chelate	1,000
SMGC020	Stoller Manganese Chelate	20
SMGC200	Stoller Manganese Chelate	200
SMGC1000	Stoller Manganese Chelate	1,000

STOLLER CHELATE ZM2 RANGE

Stoller offers a range of multi-nutrient blends, fully chelated with its proprietary phenolic chelating agent for efficient nutrient uptake and fast plant response. These blends are suitable for both foliar and soil application and include products such as Micromix, Zm2, MX Special, and ZM2 + Iron. Typical dilution is 500ml of concentrate per 200 litres of water, with an application rate of 5 litres per hectare. Please refer to our pricelist for the full range.



Product Code	Product	Size (L)
SWLM020	Stoller WL Micromix Chelate	20
SWLM200	Stoller WL Micromix Chelate	200
SWLM1000	Stoller WL Micromix Chelate	1,000
SZEC020	Stoller Zinc EDTA Chelate	20
SZEC200	Stoller Zinc EDTA Chelate	200
SZEC1000	Stoller Zinc EDTA Chelate	1,000
SZMC020	Stoller Zinc/Manganese Chelate	20
SZMC200	Stoller Zinc/Manganese Chelate	200
SZMC1000	Stoller Zinc/Manganese Chelate	1,000

Product Code	Product	Size (L)
SZM2020	Stoller ZM2 Chelate	20
SZM2200	Stoller ZM2 Chelate	200
SZM21000	Stoller ZM2 Chelate	1,000
SZM2I020	Stoller ZincM2 + Iron Chelate	20
SZM2I200	Stoller ZincM2 + Iron Chelate	200
SZM2I1000	Stoller ZincM2 + Iron Chelate	1,000
SMXS020	Stoller MX Special	20
SMXS200	Stoller MX Special	200
SMXS1000	Stoller MX Special	1,000



TERRACOTTEM® UNIVERSAL

PRODUCT CODE

TCU075 750g	TCU05 5kg	TCU10 10kg	TCU20 20kg
-----------------------	---------------------	----------------------	----------------------



TerraCottem® Universal is the original and most widely used TerraCottem soil conditioner, designed to improve plant and root growth while reducing water and fertiliser needs. Constantly evolving over the past 22 years, it now features enhanced polymers, fertilisers, and carrier materials for even better performance. Ideal for use in trees, shrubs, revegetation, annuals, perennials, roof gardens, horticulture, and potting mixes.

Key Benefits

- Healthier plants & increased yields
- Increased survival rate
- Increased water retention capacity
- Water savings up to 50%
- Stronger & deeper root development
- Faster & better plant establishment
- Higher resistance to drought and diseases
- Better use of fertiliser
- Enable plant growth in degraded, saline or otherwise marginal soils

Applications

- Tree and shrub planting
- Reforestation and land restoration
- Flower and shrub beds, roof gardens, lawns, etc.
- Window boxes, hanging baskets and containers
- Horticulture
- Agriculture

When to Apply

- Incorporate into soil when planting or seeding

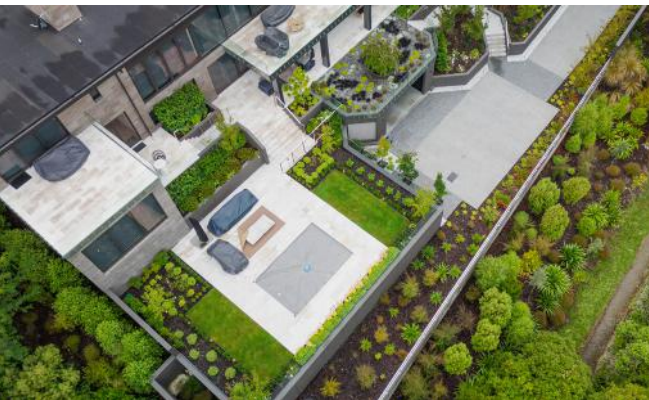

TERRACOTTEM® ARBOR

PRODUCT CODE

TCA10 10kg	TCA20 20kg
----------------------	----------------------



TerraCottem® Arbor is specially formulated for tree and shrub planting, featuring next-generation polymers, humic acids, and a tree-specific fertiliser blend. This advanced combination enhances water retention, improves soil structure, boosts microbial activity, and supports strong root and plant development. With a fertiliser lifespan of up to 12 months, it promotes rapid establishment, increases survival rates, and reduces input and replacement costs.

Key Benefits

- Increased water retention capacity
- Water savings up to 50%
- Healthier plants & increased yields
- Increased survival rates
- Better use of fertiliser
- Stronger & deeper root development
- Faster & better plant establishment
- Higher resistance to diseases and drought stress
- Enable plant growth in degraded, saline or otherwise marginal soils

Applications

- Tree & Shrub Planting

When to Apply

- Incorporate into the soil when tree planting





TERRACOTTEM® TURF

PRODUCT CODE

TCT20
20kg



TerraCottem® Turf is a specialised soil conditioner designed for turf applications. Its advanced formula includes zeolite—a natural volcanic mineral known for its high cation exchange capacity—to enhance soil fertility and water retention. Combined with turf-specific fertilisers and humates, it improves soil structure, boosts microbial activity, and increases moisture efficiency. The result is faster turf establishment, stronger root development, and improved grass quality for both seeded turf and sprigs.

Key Benefits

- Increased water holding capacity
- Water savings up to 50%
- Increased CEC value
- Less nutrient leach-off
- Better seed germination
- Stronger & deeper root development
- Increased microbiological activity
- Higher resistance to diseases and drought stress

Machinery Required for Applications

- Fertiliser spreader (preferably drop type) & rototiller

When to Apply

- Incorporate into soil prior to seeding, sprigging or sodding.



TERRACOTTEM® COMPLEMENT

PRODUCT CODE

TCC20
20kg



TerraCottem® Complement is a soil conditioner designed for flower beds and horticultural areas previously treated with TerraCottem® Universal. Complement restores nutrients and active components depleted during the growing season or lost when annuals are removed, maintaining optimal water and nutrient retention in the soil.

Key Benefits

- Healthier plants & increased yields
- Increased survival rate
- Earlier harvesting
- Increased water retention capacity
- Water savings
- Faster & better plant establishment
- Stronger & deeper root development
- Better use of fertiliser
- Higher resistance to drought and diseases

Applications

- Incorporate TerraCottem complement into the soil when planting, in areas where the "Universal" soil conditioner has been applied the previous growing season, eg. Crops (agriculture, horticulture, etc.) Flower beds

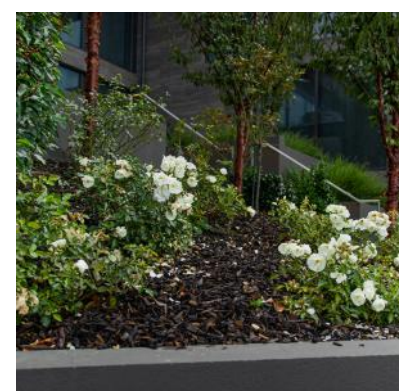



IO NATURAL GYPSUM

PRODUCT CODE

SIBGYP25

25kg

iO Natural Gypsum is a high-quality, Australian-mined soil conditioner designed to improve soil structure, reduce compaction, and supply essential nutrients to plants. This natural gypsum is blended with organic chicken manure, creating a nutrient-rich and easy-to-spread product ideal for home gardens, pastures, and horticultural applications.



MOLASSES

PRODUCT CODE

MOL025

25kg

Molasses is a natural byproduct of sugar production that boosts beneficial soil microbes by providing a rich source of sugars and carbohydrates. It enhances microbial activity, improves nutrient uptake, supports better soil structure, and promotes healthy grass growth. An eco-friendly, affordable alternative to synthetic lawn care products.

EUTECH EXPERT CTS TESTER

PRODUCT CODE

EXPERTCTS

0-1990 accuracy

The Thermo Scientific Eutech Expert CTS Pocket Tester is a reliable and portable solution for measuring conductivity, TDS, salinity, and temperature. Designed for quick and accurate on-site testing, it's ideal for use in environmental monitoring, electroplating, agriculture, education, and more. Its user-friendly interface and durable design make it a trusted tool for professionals who need precise electrochemistry data in the field.



DIGITAL SOIL PH METER KIT

PRODUCT CODE

PH212

100 Tests

The PH212 Digital Soil pH Meter Kit is a precision tool designed for quick and accurate pH testing in soil and semi-solid samples. Ideal for landscapers, growers, farmers, and educators, it features a rugged spear-tip electrode that allows easy penetration into soil and compost for reliable readings in the field or lab.

MANUTEC SOIL PH TEST KIT

PRODUCT CODE

MT08000

100 Tests

An accurate, easy-to-use, and cost-effective soil pH test kit developed from research by CSIRO soil scientists. Designed for reliability and simplicity, the kit provides results in minutes and contains enough materials to perform over 100 tests when used as directed.



CORRECTIVE SOLUTION FOR TESTERS

PRODUCT CODE

BUFFER7

pH 7 solution

A70404

Conductivity solution

This corrective solution is designed for accurate calibration of your testers. Use the pH 7 buffer solution to calibrate the pH Tester, and the conductivity solution to calibrate the Salinity Tester. Each solution is precisely formulated to ensure reliable readings and optimal performance. Supplied in convenient 1 litre bottles.



MONA PLANT SYSTEM

An advanced and proven subterranean irrigation system ideal for both interior and exterior planting. The Mona Plant System delivers water and nutrients directly to the root zone, promoting healthy root development and optimal plant growth. Versatile, cost-effective, and environmentally friendly, it's the perfect solution for landscaping projects of any scale.

Key Benefits

- A subterranean system
- Manufactured in the UK, all parts are recyclable. No mechanical, electrical or moving parts
- Simple to install
- Plant's roots absorb water from the Mona tanks as and when they require it. (capillary action)
- Eliminates over-watering and water wastage
- Aerates soil
- Reduces watering frequency



MONA PLANT SAVA SYTEM

A simple and effective solution, the Mona Plantsava System provides a reliable and natural method of irrigation. Installed at the base of a planter or pot, it allows the plant to draw up water as needed—promoting healthier, stronger growth with minimal maintenance.

- Interior and exterior landscaping
- Installed in patio, mezzanine and atrium displays around the world.
- Available in a variety of sizes to fit all containers and pots
- Can be planted at different depths to suit the plants roots
- Reservoirs range from 1L to 25L



Product Code	Plantsava Tanks	Size	Filler Pipe Length	Litre
MP1-00-00	MPS Tank 1	15 W x 6.5 H	21cm	1L
MP1-02-00	MPS Tank 2	21 W x SIZE6.5 H	33.5cm	2L
MP1-03-00	MPS Tank 3	63 L x 13 W x 6.5 H	33.5cm	3.3L
MP1-04-00	MPS Tank 4	24 W x 10 H	46cm	4L
MP1-06-00	MPS Tank 6	24 W x 15 H	59cm	6L
MP1-07-00	MPS Tank 7	55 L x 15 W x 10 H	59cm	7L
MP1-10-00	MPS Tank 10	39 W x 10 H	59cm	10L
MP1-24-00	MPS Tank 24	90 L x 20 W x 15 H	59cm	24L
MP1-25-00	MPS Tank 25	42 L x 42 W x 21 H	59cm	25L





MONA PLANT SYSTEM RING

PRODUCT CODE

MP1-RING24
24

MP2-RING77
77

Designed in response to industry demand, Mona Plant System Rings offer an efficient solution for irrigating tree rootballs and large planters. Ideal for interior landscapes and large installations, the rings ensure rapid plant establishment and healthy root development by delivering water directly around the root zone. This robust system surrounds the rootball with a consistent water supply, supporting strong growth and reducing plant stress during establishment.

Uses

- For use in hard landscaped areas with rootball trees
- Install in large decorative planters for consistent watering
- Ideal for deep planting
- Suits interior or exterior landscaping
- Particularly suitable for the establishment of large trees



MONA PLANT SYSTEM LINKS

Simple, effective, and reliable, the Mona Plantsava System is a natural irrigation method that supports healthy plant growth. Installed at the base of a planter or pot, the reservoir allows plants to draw up water as needed through capillary action. This self-watering system encourages stronger, longer-lasting plants with minimal effort.



Product Code	Plant System Liner	Size (cm)	Water Holding Volume
MP2-03-00	Link 3	63 X 13 X 6.5	3.3L
MP2-07-00	Link 7	55 x 15 x 10	7L
MP2-24-00	Link 24	90 x 20 x 15	24L
MP2-77-00	Link 77	68 x 15 x 10	8.5L

Product Code	Plant System Links	Size
MP9-12-60	End stop caps	Diameter: 60mm
MP9-01-00	Flexible connecting pipe	L 90cm Diameter: 60mm
MP9-15-00	O-ring 6	Diameter: 60mm
MP9-72-00	Filler pipe 46cm	L 46cm Diameter: 60mm
MP9-71-00	Fillerpipe 34cm	L 34cm Diameter: 35mm
MP9-73-00	Fillerpipe 59cm	L 59cm





ORBIT UNIVERSAL 7 PATTERN PLASTIC PISTOL

PRODUCT CODE

96637

The Orbit Universal 7 Pattern Plastic Pistol is a lightweight and versatile watering tool, designed to make garden and landscape irrigation easier. Built with a durable plastic body, it offers seven unique spray patterns to suit a variety of watering needs – from gentle misting for delicate plants to powerful jet spray for cleaning tasks.



ORBIT PLATINUM SPRAY GUN

PRODUCT CODE

SM-PISTOLADJ

This high-quality hose gun makes hand-watering easier and more enjoyable. Constructed from heavy-duty cast metal, it features a non-slip cushioned grip for added comfort and control. The fully adjustable brass nozzle allows you to switch from a fine mist to a powerful jet stream, making it ideal for a variety of tasks. A gentle-action water saver trigger with positive shut-off and trigger lock ensures ease of use. Compatible with standard 12mm click-on or screw-on fittings.

ORBIT SHOWER WAND

PRODUCT CODE

58581B

This ultra-lightweight 975mm watering wand is designed to mimic natural rainfall, providing gentle and even water distribution. It features an on/off valve for easy control, includes a tap fitting for quick connection, and has a replaceable head for long-term use. Ideal for reaching hanging baskets, garden beds, and delicate plants.

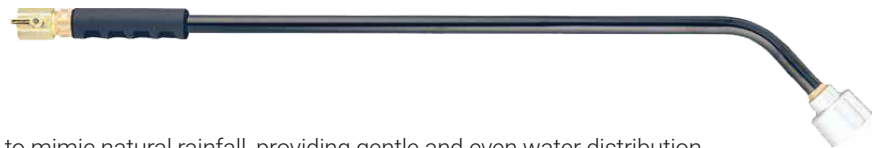



EZ-FLO FERTIGATION SYSTEM

PRODUCT CODE

EZ-2005HB
2.8L

A convenient and efficient system for applying concentrated liquid fertilisers to lawns, gardens, and plants. Simply fill the canister, connect to your hose or irrigation setup, adjust the settings, and you're ready to go. Ideal for larger properties or lawn care professionals looking to save time and effort.



EZ-FLO – FERTILISER INJECTION SYSTEM (TAP)

PRODUCT CODE

EZ-1010HB
3.2L

The EZ-FLO 3.2L Injection System is the ideal solution for applying liquid or soluble granular fertiliser to home gardens and lawns. Designed to connect directly to your garden hose, it delivers nutrients efficiently with every drop of water. Easy to use and highly effective, it's a popular choice among home gardeners across Australia and New Zealand for boosting plant health and lawn appearance without the hassle of watering cans or sprayers.

EZ-FLO - FERTILISER INJECTION SYSTEM (MAINLINE)

PRODUCT CODE

EZ-FLO1
3.2L

EZ-001CX
5.7L

EZ-003CX
9.4L

EZ-005FX
17L

EZ-FLO's High-Capacity Main Line Systems connect directly to your pump or backflow prevention device, automatically delivering precise doses of fertiliser through your sprinkler or drip irrigation system. Designed for seamless integration, it treats multiple zones without the need for manual adjustments—making it ideal for efficient, large-scale fertigation.



EZ-FLO EZKIT FERTILISER INJECTION SYSTEM WITH FILL CAP & DRAIN

PRODUCT CODE

EZ-KIT-1
6.7L

EZ-KIT-3
9.6L

EZ-KIT-5
19L

EZKIT systems are built with the same trusted construction as the CX range but now include advanced features previously reserved for high-capacity models. With a proprietary fill system, EZKIT units offer nearly double the water-soluble powder capacity of CX models—extending refill intervals and allowing for broader coverage across larger areas.

EZ-FLO HIGH-CAPACITY FERTILISER INJECTION SYSTEM

PRODUCT CODE

EZ-HC-010
38L

EZ-HC-017
66L

EZ-HC-025
94L

The High-Capacity Main-Line Systems revolutionise your fertilising and watering setup with a specialised fill system that doubles water-soluble product capacity—no need to remove the cap for refills. Featuring a larger drain valve, automatic air vent valve, and a heavy-duty body for enhanced durability, these systems are built for reliable, maintenance-free performance. A CBV ball valve coupling adapter is required for installation.





EZ-FLO COUPLING CONNECTOR

PRODUCT CODE

PA-CBV-075 20mm	PA-CBV-100 25mm	PA-CBV-125 32mm	PA-CBV-150 40mm
PA-CBV-200 50mm	PA-CBV-300 80mm	PA-CBV-400 100mm	

The EZ-FLO Coupling Connector with Ball Valve (CBV) is a vital component for connecting any EZ-FLO tank system to your main irrigation line. Available in sizes from 20mm to 100mm, the CBV ensures a secure, leak-free connection and precise flow control. Compatible with all EZ-FLO systems, it allows seamless integration into a wide range of irrigation setups.



REOTEMP SOIL MOISTURE METER

PRODUCT CODE

LSMM24

The REOTEMP Soil Moisture Meter is a simple and effective tool for measuring soil or compost moisture levels using a sensor at the tip of the probe. With a clear 0 to 10 scale, it provides a quick reference for determining whether your soil is too dry or sufficiently moist—helping you water more efficiently. Ideal for gardening and composting, the meter includes printed calibration instructions on the head for convenience and comes with a 1-year limited warranty. Please note: it provides a relative moisture reading, not a percentage.

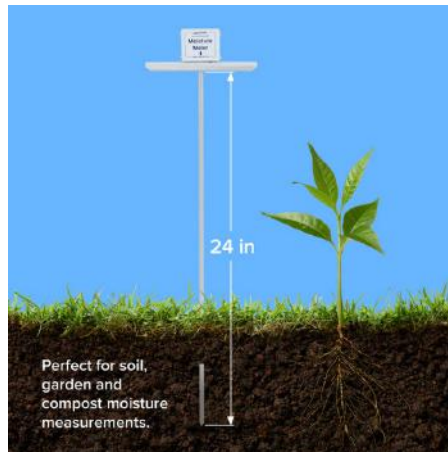



TERRACOTTEM[®]
Leading soil conditioning technology

**MORE
GROWTH,
LESS WATER**



ASK US HOW!

terracottem.com.au





SECTION 9

**WEED AND PEST
CONTROL**



DYES

APPARENT RED VEGETABLE MARKER DYE

PRODUCT CODE

A16678	A16679	A16694
1L	5L	20L

Apparent Red Vegetable Marker Dye is a red-coloured liquid dye used to visually mark sprayed areas, helping reduce overlaps and missed spots during application. It is ideal for use with herbicides, insecticides, and fungicides, and can also colour foam markers for improved visibility. Contains Disazo Dye Preparation as the active constituent.



INDIGO BLUE SPRAY MARKING DYE

PRODUCT CODE

IBD05	IBD20
5L	20L

Indigo Blue is a high-quality liquid marking dye designed to clearly identify sprayed areas, reducing the risk of over-application and costly mistakes. Ideal for use in all spraying situations, it can also be added to white foam markers to turn the foam blue for clearer visibility. Easy to use and compatible with most spray equipment, Indigo Blue is available in both 5L and 20L sizes—perfect for small or large-scale applications.



ENVIRODYE RED MARKING DYE

PRODUCT CODE

E41140	E40915	E17361
1L	5L	20L

Envirodye Red is a coloured marking dye that helps clearly identify sprayed areas during application. This simple and cost-effective solution reduces the risk of over-application and missed spots, making it ideal for all spraying situations.



ENVIRODYE BLUE MARKING DYE

PRODUCT CODE

E9627F	E40916	E40920
1L	5L	20L

Envirodye Blue is a coloured marking dye designed to clearly identify sprayed areas during application. It's a simple, cost-effective solution that helps reduce over-application and ensures complete coverage, making it ideal for all spraying situations.



ENVIRODYE AQUA WATER DYE

PRODUCT CODE

E9633
5L

Envirodye Aqua is a coloured dye designed to enhance the appearance of lakes and ponds while also helping to slow the growth of algae and aquatic weeds. It provides both aesthetic and functional benefits, making it ideal for water feature maintenance.





ADJUVANTS

PROFORCE MONTERAY PENETRANT

PRODUCT CODE

PMR01	PMR05
1L	5L

ProForce Monterey Surfactant is a powerful adjuvant designed to optimise the performance of herbicides, insecticides, fungicides, and plant growth regulators. Its unique formulation contains 350 g/L Soyal Phospholipids and 350 g/L Propionic Acid, working together to deliver highly effective results in agricultural and turf management applications.



APPARENT DEVOUR 1020

PRODUCT CODE

A12956
20L

Apparent Devour 1020 is a high-performance organosilicone super-wetter designed to dramatically improve spray coverage and effectiveness. With up to 13 times more spreading power than standard surfactants, it enhances droplet distribution and penetration—particularly useful when applying herbicides to hard-to-control woody weeds. Containing 1021 g/L Polyether Modified Polysiloxane, it's comparable to products like Alphakem Consume and Nufarm Pulse.



APPARENT GLYASSIST 1040

PRODUCT CODE

A17872
20L

Apparent Glyassist 1040 is a premium, concentrated non-ionic surfactant designed to enhance the performance of agricultural sprays. It reduces surface tension, allowing for better wetting and spreading on waxy leaf surfaces. At higher application rates, it also improves the uptake of systemic herbicides like glyphosate. Containing 1040 g/L Octyl Phenol Ethoxylate, it is comparable to SST Trilogy and Syngenta Agral.



PULSE PENETRANT

PRODUCT CODE

P41001
5L

Pulse is a high-performance organosilicone super-wetter designed to dramatically improve spray coverage and penetration. It enhances the spread of droplets on leaf surfaces by up to 13 times more than standard surfactants, ensuring better uptake and translocation of herbicides—particularly when targeting hard-to-control woody weeds. Active ingredient: 1,020 g/L polyether modified polysiloxane.



SYNERTROL HORTI OIL

PRODUCT CODE

SYN05	SYN20
5L	20L

Synertrol is a certified organic botanical oil concentrate formulated to enhance the effectiveness of pesticides, herbicides, and foliar nutrients. When used as directed, it improves wetting and penetration of sprays, increases rainfastness, reduces chemical leaching and spray drift, and acts as a spray deodoriser to minimise chemical odors.





FUNGICIDES & ALGAEICIDES



APPARENT SULPHUR 800

PRODUCT CODE

A7727

15kg

Apparent Sulfur 800 is a broad-spectrum fungicide and miticide designed to protect a wide range of crops and plants from fungal diseases and pest infestations. It offers effective control of powdery mildew, rust, and mites in grapes, pome and stone fruit, ornamentals, citrus, and vegetables.

ALGAE AID

PRODUCT CODE

IAA005

5L

A soluble sulphur formulation used to control a range of fungal diseases in grape vines, ornamentals, pome and stone fruit, and vegetables. It also effectively manages mites in citrus, grape vines, ornamentals, and vegetables, as well as white louse scale in citrus. Additionally, it can be used to correct soil pH, making it a versatile solution for plant health and soil management.



PROFORCE SHRAPNEL 600SL

PRODUCT CODE

PS600

5L

ProForce Shrapnel 600SL Fungicide contains 600g/L Propamocarb Monohydrochloride and is specifically formulated to control Pythium in turf and ornamental plant applications. Highly effective and versatile, it's a trusted solution for landscapers, turf managers, and horticulturists aiming to protect plant health and prevent the damaging effects of Pythium disease.



AZO-FORCE 250SC

PRODUCT CODE

IAF250

2.5L

Azo-Force 250SC is a broad-spectrum fungicide containing 250g/L Azoxystrobin, designed to control a wide range of turf diseases including Anthracnose, Grey Leaf Spot, Brown Patch, Red Thread, Pythium, and more. Suitable for use across all turf settings—golf courses, sports fields, and residential lawns—it delivers powerful control even in severe infestations. Its high concentration and broad application make it a reliable and versatile solution for turf managers and landscapers seeking effective disease control.



SEGWAY 400SC

PRODUCT CODE

SWF05

500ml

SWF1

1L

Segway® 400SC Fungicide offers powerful, targeted control of Pythium Blight and Pythium Root Dysfunction across all turf management settings. With its unique Group 21 mode of action, Segway delivers both preventative and curative protection to keep turf healthy and resilient. Available in 500mL and 1L bottles, it's ideal for applications ranging from residential lawns to sports fields. Choose Segway 400SC for proven performance and peace of mind against destructive turf diseases.





PROFORCE CLEAN SWEEP TRIO

PRODUCT CODE

PFCS05

5L

This advanced fungicide features Tri-Active Control Technology for powerful, multi-site protection against common turf diseases. With three active ingredients—Thiophanate-methyl, Fluazinam, and Tebuconazole—it targets multiple points within fungal cells to control both active infections and prevent new outbreaks. Ideal for managing diseases like Anthracnose, Brown Patch, Dollar Spot, ERI fungi, Fairy Ring, and Helminthosporium, it helps promote healthier, more resilient turf and lawns.



PROFORCE REGIMENT 550EC

PRODUCT CODE

PFREG10

10L

ProForce Regiment 550EC is a high-strength fungicide containing 550g/L of Propiconazole, formulated with reduced solvent loading for a lower environmental impact. It provides broad-spectrum control of turf diseases including Spring Dead Spot, Dollar Spot, Stem Rust, and Take All Patch, and is also effective against Blind Seed Disease in Perennial Ryegrass and Rust in ornamental Boronia. Made in Australia, Regiment 550EC offers powerful, reliable performance for maintaining healthy, resilient turf.

PROFORCE VOLTAR 500SC

PRODUCT CODE

PFVOL05

5L

Voltar® 500SC is a broad-spectrum fungicide containing 500g/L Iprodione, registered for the control of key turf diseases including Brown Patch, Dollar Spot, Fusarium Patch, Curvularia, Spring Dead Spot, and Helminthosporium in recreational turf settings. It is also effective against Botrytis Blight in ornamental plants. This water-based suspension concentrate is ideal for targeting root-zone pathogens, offering reliable protection for healthy, resilient turf and ornamentals.



ECO-CARB

PRODUCT CODE

EC005

5kg

EC020

20kg

Eco-Carb is a certified organic fungicide formulated with potassium bicarbonate to effectively control Powdery Mildew and Black Spot in a wide range of horticultural plants and crops. Safe, non-toxic, and environmentally friendly, Eco-Carb is ideal for use in sensitive areas such as schools, shopping centres, and organic farms. Regular application helps maintain healthy, disease-free plants.



LIQUID LIME SULPHUR

PRODUCT CODE

8852

20L

Liquid Lime Sulphur is a concentrated fungicide and insecticide formulated for the control of a range of common garden pests and diseases. Suitable for use on roses, vines, fruit trees, vegetables and ornamental plants, it targets fungal infections and certain insect pests during the dormant or growing seasons (as per label directions).





FUNGICIDES & ALGAEICIDES

APPARENT CAPTAN 900 WG

PRODUCT CODE

A8000

10kg

Apparent Captan 900 is a powerful fungicide used to control diseases such as Black Spot, Grey Mould, Downy Mildew, and Brown Patch across fruit crops, turf, and ornamentals. With 900g/kg of Captan as the active constituent, it delivers reliable protection and is comparable to CropCare Captan 900 and Sipcam Captan WG.



APPARENT MANCOZEB 750 DF

PRODUCT CODE

A4118

20kg

Apparent Mancozeb 750 is a broad-spectrum fungicide used to control a range of fungal diseases in fruit, field crops, turf, vegetables, and ornamentals. It contains 750g/kg of Mancozeb and is a reliable alternative to Dow Dithane.

NON-SELECTIVE HERBICIDES

GRYPHON GLYPHOSATE 450

PRODUCT CODE

GG45020

20L

A reliable, broad-spectrum herbicide formulated with 450 g/L glyphosate for effective control of annual and perennial broadleaf and grassy weeds. Ideal for pre-harvest, burndown, and stock grazing applications. Delivers long-lasting results with an environmentally conscious formulation suited to modern crop protection needs.



ZERO TRIPLE STRIKE PROFESSIONAL WEEDKILLER CONCENTRATE

PRODUCT CODE

57181

20L

A powerful, glyphosate-free weedkiller designed for professional use. Zero Triple Strike targets both broadleaf and grassy weeds with a triple-action formula that penetrates foliage, kills roots, and helps prevent regrowth. Its broad-spectrum control makes it ideal for maintaining clean, weed-free gardens, landscapes, and outdoor areas.

APPARENT GLYPHOSATE 450

PRODUCT CODE

A24718

1L

AP17231

5L

AP9445

20L

AP9446

1000L

A high-performance, non-selective foliar herbicide for broad-spectrum control of annual, perennial, and aquatic weeds. Containing 450 g/L glyphosate (as the isopropylamine salt), it offers rapid brown-out, rain-fast action, and effective translocation from leaf to root. Ideal for seedbed prep, fallow management, pasture renovation, and spot treatment.





APPARENT CONCUSSION 540K

PRODUCT CODE

A9314	A9345
20L	110L

A high-load, non-selective herbicide containing 540 g/L glyphosate (as the potassium salt) for fast and effective control of annual and perennial weeds. With rapid uptake and enhanced rainfastness, it's ideal for time-critical knockdown applications. Suitable for use in agricultural, horticultural, forestry, and industrial settings. Comparable to Roundup PowerMax® and Sipcarn Firebolt®.



APPARENT GLYPHOSATE GREEN 360

PRODUCT CODE

AP9068	AP9069	AP9071
1L	5L	20L

A glyphosate herbicide formulated with special salts that do not bio-accumulate in the soil, making it safer for use around sensitive natural environments. Ideal for applications near streams, waterways, and conservation areas where minimal environmental impact is essential.

TRIMAC INDUSTRIAL WDG

PRODUCT CODE

TM01
1kg

Trimac Herbicide is a powerful residual herbicide that provides long-term weed control from a single application, reducing the need for repeated spraying and labour. It delivers both knockdown and extended soil activity to prevent new weed germination. For best results on established weeds, mix with Glyphosate for immediate control and lasting protection—ideal for industrial and non-crop areas.



SLASHER WEEDKILLER

PRODUCT CODE

SOH01	SOH05	SOH20
1L	5L	20L

Slasher Weedkiller is a certified organic, non-selective contact herbicide made from Pelargonic Acid, a naturally occurring compound in plants like pelargoniums, apples, and grapes. It offers effective weed control with no environmental risk—non-toxic to animals, non-mutagenic, non-carcinogenic, and biodegradable with a soil half-life of just 1.6 days. Ideal for safe, eco-friendly weed management.



APPARENT WEEDSHOT 200

PRODUCT CODE

A8192	A8193
5L	20L

Apparent Weedshot 200 is a non-selective, post-emergent herbicide containing 200 g/L Glufosinate-ammonium for effective control of a broad spectrum of annual and perennial weeds. It delivers fast knockdown through foliar uptake and leaves no residual soil activity, making it ideal for use in vineyards, tree crops, industrial areas, and fallow land. Weedshot 200 is a strong glyphosate alternative where replanting flexibility and minimal soil disturbance are priorities.





APPARENT ALTERNATIVE

PRODUCT CODE

A25884
1L

A25885
5L

A25886
20L

Apparent Alternative Herbicide is a powerful solution that provides non-selective control of seedling and young broadleaf and grass weeds. It is also effective for the suppression of established weeds and perennial species, as well as the control of Moss and Algae, according to the directions for use.



APPARENT WEEDY SEEDY 250

PRODUCT CODE

A8932
20L

A8933
110L

Apparent Weedy Seedy is a fast-acting, non-selective herbicide used for the control of a broad range of grasses and broadleaf weeds. Containing 135g/L Paraquat and 115g/L Diquat with a built-in non-ionic wetter, it is ideal for use in crop establishment programs. Available in 20L and 110L pack sizes, it is a reliable alternative to Syngenta Spray-Seed.

PROFORCE NUMCHUK

PRODUCT CODE

PNC01
1L

PNC20
20L

ProForce Numchuk Quad Herbicide is a powerful solution offering both post- and pre-emergence weed control for up to 12 months. Featuring Quad Control Herbicide Technology, it combines four herbicides from different mode of action groups to deliver broad-spectrum and long-lasting results. Ideal for farmers, landscapers, and homeowners, Numchuk Quad helps maintain weed-free areas and supports healthy plant growth.



SELECTIVE HERBICIDES

COLISEUM

PRODUCT CODE

COLI001
100g

Coliseum Herbicide delivers reliable control of tough Wintergrass and Ryegrass genotypes that other products often miss. With strong root uptake and quick wash-in—just one hour after application—it minimises off-target movement and turf damage. Apply irrigation before morning foot traffic to reduce reactivation risk from dew. Active Constituent: 250g/kg Rimsulfuron



PROFORCE ECHELON DUO

PRODUCT CODE

EDH20
20kg

Echelon Duo Advanced Herbicide + Insecticide is a dual-action turf treatment combining Oxadiazon, a powerful pre-emergent herbicide, with Thiamethoxam, a residual insecticide. It effectively controls Summergrass, Crowsfoot, Wintergrass, and Creeping Oxalis, while also targeting African Black Beetle, Argentinian Scarab, and Billbug. Formulated on a homogenous 15:1:17 fertiliser base, it supports strong turf growth and improved overall performance.



PROFORCE DUKE

PRODUCT CODE

PDH100
100g**PDH500**
500g

ProForce Duke 100WG Herbicide is a selective herbicide for the control of a wide range of broadleaf and grass weeds, including Bindii, White Clover, Oxalis, Ryegrass, and Wintergrass (suppression). Powered by Iodosulfuron methyl sodium, it offers reliable post-emergent weed control in turf. Available in 100g and 500g pack sizes.

APPARENT AXEMAN 600

PRODUCT CODE

A6273
10L

A powerful woody weed herbicide containing 600g/L Triclopyr, targeting a wide range of broadleaf weeds. Classified as a Group 1 herbicide, Axeman 600 disrupts plant cell growth, effectively stopping weed development. Ideal for the control of woody weeds and melons. Refer to the product label for specific application directions.



APPARENT BAYONET 750 WG

PRODUCT CODE

A7173
1kg

A water-dispersible granule herbicide containing 750 g/kg Diflufenican for pre- and post-emergent control of broadleaf weeds in wheat, barley, and oats. Offers residual control of weeds like wild radish, capeweed, and doublegee. Effective for early-season management, with pre-emergent use permitted in WA only.

APPARENT CHAINSAW 250

PRODUCT CODE

A5657
10L

A selective herbicide for effective control of broadleaf weeds, annual and perennial grasses, and woody weeds. Designed for use in Pinus radiata plantations, pastures, commercial and industrial areas, and rights of way. Provides reliable, long-lasting weed control to support healthier crops and improved pasture productivity.



APPARENT MCPA 750

PRODUCT CODE

A11893
5L**A11892**
20L**A12885**
110L**A12982**
1000L

A high-strength, selective herbicide containing 750g/L MCPA (dimethylamine salt) for effective broadleaf weed control in turf, pastures, cereal crops, and fallows. This systemic, non-volatile formulation is suitable for use on most turf types, including Buffalo, and is ideal for both newly laid and established turf. Trusted by contractors, councils, and turf professionals.

APPARENT RAVAGE

PRODUCT CODE

A7490
1L**A7614**
5L**A7687**
20L

A reliable broadleaf herbicide for turf with proven performance on over 35 registered weeds, including Catsear, Creeping Oxalis, Clover, and Dandelion. Contains 340g/L MCPA and 80g/L Dicamba. Suitable for boom or knapsack application and available in multiple pack sizes to suit all turf management needs.





SELECTIVE HERBICIDES

APPARENT HALOXYFOP 520

PRODUCT CODE

A7051

5L

Apparent Haloxypop 520 is a high-strength, selective post-emergence herbicide containing 520 g/L haloxypop-p, designed for the effective control of annual and perennial grass weeds in broadleaf crops. Absorbed through the foliage and translocated throughout the plant, it delivers reliable knockdown across various settings, including canola, pulses, vegetables, forestry, and vineyards. Ideal for targeted weed management where grass competition impacts crop productivity.



APPARENT DEMOLISH

PRODUCT CODE

A23134

10L



Apparent Demolish Herbicide is a selective, fast-acting herbicide formulated for effective control of hard-to-manage grassy and broadleaf weeds in turf. Ideal for use on common couch, bent, and fescue lawns, it targets weeds such as Paspalum, Summergrass, Crab Grass, Mullumbimby Couch, Nut Grass, and Sedges. Suitable for turf professionals, it provides long-lasting control while helping maintain a healthy, uniform appearance in bowling greens, golf courses, parks, and lawns.

APPARENT QUIZALOFOP 200 EC

PRODUCT CODE

A1768

10L

Apparent Quizalofop 200 EC is a selective post-emergent herbicide containing 200 g/L Quizalofop-P-ethyl, designed to control a broad range of annual and perennial grass weeds in broadleaf crops. It provides fast, systemic action by moving through the foliage to the roots, ensuring thorough control and protecting crop yields. Suitable for use in vegetables, pulses, oilseeds, and pasture legumes.



APPARENT OXYFLURAFEN 240

PRODUCT CODE

A6615

5L



Apparent Oxyflurafen 240 is a selective pre- and post-emergent herbicide containing 240 g/L oxyfluorfen, offering reliable control of a broad spectrum of annual broadleaf and grass weeds. With long-lasting residual activity, it is ideal for use in horticulture, tree crops, vineyards, and non-crop areas like roadsides, fence lines, and industrial sites.

APPARENT WOODY

PRODUCT CODE

A8326

1L

A8110

5L

A8111

20L

Apparent Woody is a dual-active herbicide containing Triclopyr and Picloram, designed for effective control of woody weeds and unwanted tree species in pastures, forestry, rights-of-way, and non-crop areas. It offers both systemic and residual action for long-lasting suppression of tough species like blackberry, gorse, lantana, and boxthorn. Suitable for foliar spray, basal bark, or cut stump application.





APPARENT SWORD 750 WG

PRODUCT CODE

A4692

1kg

Apparent Sword 750 WG is a selective herbicide containing 750 g/kg Clopyralid, formulated as a water-dispersible granule. It provides effective control of broadleaf weeds such as capeweed, thistles, volunteer legumes, and skeleton weed in winter cereals, pastures, and fallow areas. Suitable for use in wheat, barley, oats, and triticale, it offers reliable systemic action through both foliar and root uptake.



APPARENT HALOSULFURON 750 WG

PRODUCT CODE

A1420

25g

A1544

100g

A1761

500g

Apparent Halosulfuron 750 is a selective post-emergent herbicide for the control of Nutgrass and Mullumbimby Couch in turf and various crop situations. Containing 750 g/kg Halosulfuron-Methyl, it delivers reliable and targeted weed control. Available in 25g, 100g, and 500g pack sizes, it offers a trusted alternative to products like Nufarm Sempra.

APPARENT BROMOXYNIL + MCPA

PRODUCT CODE

A16423

20L

A selective herbicide for broadleaf weed control in parks, golf courses, and home lawns. Safe for use on Couch, Kikuyu, Paspalum, Buffalo, Fescue, Bent, and Rye grasses. Effectively controls Bindii, Jo-Jo, Clover, Dandelion, Thistles, Oxalis, and more. Active: 200g/L Bromoxynil + 200g/L MCPA.



FUSILADE

PRODUCT CODE

F43651

1L

F42822

5L

Fusilade Forte is a selective post-emergent herbicide designed to control a wide variety of annual and perennial grass weeds in broadleaf crops, orchards, vineyards, and ornamental plants. Its application rate varies based on the targeted weed species, providing effective and flexible grass weed management across multiple settings.

BOW & ARROW

PRODUCT CODE

BOWARR005

500ML

BOWARR10

10L

Bow & Arrow Herbicide is a premium broadleaf weed control solution for turf, combining MCPA, clopyralid, and diflufenican for season-long effectiveness. Its slow-acting formulation ensures thorough weed kill with minimal regrowth, while offering superior turf safety for both cool- and warm-season grasses. Ideal for controlling common broadleaf weeds such as clover, bindii, capeweed, and creeping oxalis, it requires no additional surfactants and has no odour or volatility concerns.





SELECTIVE HERBICIDES

KAMBA M

PRODUCT CODE

K42401

5L

K41176

20L

Kamba M is a trusted and proven selective herbicide for broadleaf weed control in turf, with over 35 registered weed targets including catsear, creeping oxalis, clovers, and dandelion. Suitable for use on general turf, golf courses, and bowling greens, it can be applied via boom or knapsack sprayers. Contains 340 g/L MCPA and 80 g/L dicamba.



SPEARHEAD

PRODUCT CODE

J42790

10L

Spearhead Herbicide is a selective broadleaf weed control solution for turf, targeting common weeds like white clover, plantain, capeweed, cat's ear, bindii, jo-jo, cudweed, and creeping oxalis. Suitable for professional turf management, it is applied at 5 L per hectare in 200–500 L of water and comes in 10 L containers.

BROADSIDE

PRODUCT CODE

B42801

20L

Broadside is a powerful three-way selective herbicide designed for economical and effective control of broadleaf weeds in turf. With multiple modes of action from its active ingredients—280 g/L MCPA, 140 g/L bromoxynil, and 40 g/L dicamba—it delivers fast and reliable control of common weeds such as capeweed, clovers, and oxalis across a range of turf situations.



DISMISS

PRODUCT CODE

MS0059

10kg

Dismiss Herbicide is a granular, dual-active solution providing up to 3 months of weed control for over 40 species in both potted and open-grown ornamentals. Trusted in nursery and landscaping applications, it's easy to apply, low in dust and odor, and offers long-lasting protection without harming your plants when used as directed.

RONSTAR

PRODUCT CODE

R42363

15kg

Ronstar is a pre-emergent herbicide that provides up to 10 weeks of control against germinating weed seedlings in nurseries and turf areas. Ideal for managing weeds before they emerge, it offers reliable protection to maintain clean, healthy growing environments.





APPARENT SIMAZINE 900 WG

PRODUCT CODE

A9541

15kg

Apparent Simazine is a pre-emergent herbicide that targets weeds through root absorption, making it most effective when applied to bare, moist soil and followed by rain or irrigation within two weeks. Ideal for long-lasting weed control, its effectiveness depends on soil type, application rate, and weed species. It can be tank-mixed with a variety of other herbicides for broader control.



SPARTAN PRE-EMERGENT

PRODUCT CODE

SPAR0025

250ml

SPAR005

500ml

SPAR10

10L

Spartan Herbicide provides effective, season-long pre-emergent control of major annual grass weeds, including winter grass, in turf. It targets weed seeds before germination, reducing future infestations and seed set. Compatible with wetting agents, Spartan is a reliable alternative to Syngenta Barricade for preventative weed management in lawns and turf areas.

APPARENT SALVO 212

PRODUCT CODE

A10465

1L

A10466

5L

A10467

20L

A selective post-emergent herbicide containing 212 g/L Fluazifop-P for effective control of annual and perennial grass weeds in broadleaf crops, orchards, vineyards, forestry, and industrial areas. Offers precision grass control without harming broadleaf plants. A reliable alternative to Syngenta Fusilade®.



APPARENT BOW SAW 600

PRODUCT CODE

A3883

500g

Apparent Bow Saw Metsulfuron 600 is a selective herbicide designed for the control of broadleaf weeds in winter cereals, pastures, rights of way, and industrial areas. Containing 600g/kg metsulfuron-methyl, it delivers targeted and effective control of brush species and problem weeds while minimising impact on non-target plants. Ideal for sustainable weed management across agricultural and non-crop settings.



PESTICIDES

PROFORCE RUMBLER 100SC

PRODUCT CODE

PR01

1L

PR05

5L

Rumbler 100SC Insecticide is a versatile, broad-spectrum insecticide containing 100g/L bifenthrin, designed for use in turf, ornamental plants, and structural pest control. It effectively controls lawn pests like Lawn Armyworm, African Black Beetle, and Billbug, as well as mites, caterpillars, ants, spiders, cockroaches, mosquitoes, and termites. Suitable for recreational turf, gardens, and around buildings, Rumbler 100SC offers comprehensive pest protection across various environments.



PROFORCE SCARLET TRIO ADVANCED

PRODUCT CODE

STA01

1L

STA05

5L

ProForce Scarlet Trio Advanced Insecticide is a cutting-edge 3-way insecticide blend featuring Tri-Active Control Technology for powerful and extended pest control. It delivers up to 90 days residual activity in soil and 28 days on foliage, targeting 8 key insect pests with both contact and systemic action. Uniquely registered for Ground Pearl control in turf, it also effectively manages Couch Mite, African Black Beetle, Billbug, and Argentinian Scarab.



PROFORCE MALICE DUO MITICIDE

PRODUCT CODE

PMD01

1L

PMD05

5L

ProForce Malice Duo Advanced Miticide is a dual-active miticide designed for effective control of Couch Mite in all turf situations. Containing 18g/L abamectin and 187.5g/L clofentezine, this suspension concentrate ensures even application and reliable mite knockdown. Ideal for use on golf courses, sports fields, and residential lawns, Malice Duo offers a fast-acting, targeted solution for turf professionals seeking dependable mite control.



APPARENT STOCKADE

PRODUCT CODE

A8191

5L

This product is a broad-spectrum insecticide and miticide designed to control a wide range of insect pests and mites across various crops. It is registered for use on apricots, bananas, barley, canola, citrus, clover, cotton, faba beans, field peas, grapes, lucerne (and lucerne seed crops), lupins, navy beans, nectarines, peaches, pears, plums, subterranean clover, sugarcane, tomatoes, and wheat, as detailed in the directions for use table.



APPARENT COCKY 200SC

PRODUCT CODE

A9308

1L

A9309

5L

A9419

20L

Apparent Cocky 200 is a versatile systemic insecticide containing 200 g/L imidacloprid, designed to control a wide range of insect pests such as aphids, whiteflies, thrips, lacebugs, and mealybugs. Suitable for use on crops, vegetables, ornamental plants, roses, and turf, it offers flexible application via spray or watering systems. Available in 1L, 5L, and 20L sizes, Apparent Cocky 200 delivers effective, long-lasting pest control across both residential and commercial settings. Comparable to Bayer Confidor and PCT Surefire Spectrum.





PROFORCE MALICE 18 MITICIDE

PRODUCT CODE

PMM18
20L

Malice 18 Miticide is a powerful translaminar miticide containing 18g/L abamectin, formulated as an easy-to-apply emulsifiable concentrate. It provides effective control of Couch Mite in all turf situations and is also registered for managing Two Spotted Mite in ornamental plants such as roses, chrysanthemums, and indoor foliage. Ideal for turf managers, landscapers, and horticulturists, Malice 18 promotes healthy turf and ornamental plant growth by delivering targeted, reliable mite control.



APPARENT DINGO 500

PRODUCT CODE

A8654 1L **A8655** 5L **A8656** 20L **A5290** 110L

This broad-spectrum, economical insecticide delivers rapid knockdown and some residual control of common turf pests. It is registered for use against a variety of insects including Argentine Stem Weevil, African Black Beetle, Black Headed Cockchafer, Funnel Ants, and Crickets, making it a reliable choice for effective turf pest management.

APPARENT SURROUND BIFENTHRIN 100SC

PRODUCT CODE

A8188 1L **A8189** 5L

Apparent Surround is a broad-spectrum insecticide used to protect structures from subterranean termites and control a wide range of pests including ants, cockroaches, mosquitoes, fleas, flies, ticks, paper nest wasps, spiders, and more as specified on the label. Ideal for pest control in and around buildings.



APPARENT ANTASSASSIN

PRODUCT CODE

A19146 1kg **A19147** 15kg

Apparent Antassassin is a granular insecticide formulated for the control of key turf pests including Armyworm, Argentine Stem Weevil, African Black Beetle, Billbug, and various ant species. It is also effective against ants, fleas, and ticks around external building areas. Containing 2 g/kg Bifenthrin, Antassassin offers targeted and reliable pest control and is available in convenient 1kg and 15kg pack sizes.

APPARENT ONSLAUGHT

PRODUCT CODE

A4110 1L **A4111** 5L

Apparent Onslaught is a broad-spectrum insecticide containing 200 g/L Fipronil, designed to protect crops such as bananas, brassicas, cotton, grapevines, mushrooms, pasture, potatoes, sorghum, and sugarcane. It offers powerful control of key insect pests while helping preserve beneficial insects, supporting sustainable farming. With flexible application options and proven performance, Apparent Onslaught is a trusted choice for reliable crop protection and improved yields.





PESTICIDES

APPARENT INSECT & SPIDER SPRAY

PRODUCT CODE

A8190

1L

A12679

5L

Apparent Insect & Spider Spray is a ready-to-use insecticide designed to control a broad range of insect pests in domestic, commercial, and industrial settings. Formulated with 10 g/L Deltamethrin, it effectively targets ants, spiders, cockroaches, and other common pests. Available in 1L and 5L sizes, it provides fast knockdown and residual protection. Comparable to PCT Insectigone 10, this product is ideal for both indoor and outdoor use.



ORGANIC



AZAMAX

PRODUCT CODE

AZ01

1L

AZ05

5L

Azamax is a natural insecticide derived from the neem seed kernel, containing the potent active ingredient Azadirachtin. Functioning primarily as an Insect Growth Regulator (IGR), Azamax disrupts insect development and growth, effectively controlling a wide range of pests including aphids, two-spotted mites, fungus gnats, caterpillars, and whitefly. Ideal for environmentally conscious pest management, Azamax offers broad-spectrum control with multiple modes of action.

INSECT GLUE TRAPS

PRODUCT CODE

IGT8

8pk

IGT5

5pk

Insect Glue Traps come in small (7cmx12cm) and extra-large (20x15cm) and feature an ultra-sticky, proprietary 'dry glue' strong enough to catch even mice. Designed to attract and trap flying insects, these traps help monitor pest activity around your plants, enabling timely and preventative pest control. Ideal for indoor growing spaces—hang at various positions and heights and check daily. Each pack contains 5 traps or 8 traps



ECO-SHIELD SNAIL & SLUG KILLER

PRODUCT CODE

O56404

25kg

OCP eco-shield Organic Snail & Slug Killer is a safe and effective molluscicide for controlling snails, slugs, and slaters in agricultural and horticultural settings. Formulated with 10 g/kg iron powder, it is highly palatable to target pests and delivers rapid action—even in cooler temperatures—without relying on dehydration. Its pellet design offers excellent weather resistance and improved contact. Free from scheduled poisons like metaldehyde and methiocarb, eco-shield is safer for users, domestic animals, and ideal for public or sensitive areas. Certified organic for peace of mind.



ORGANIC

INITIATOR TABLETS

PRODUCT CODE

I79701306

300 Tablets

I79412924

1,200 Tablets

Initiator Tablets support healthy plant growth while providing 2–3 months of protection against damaging pests including beetles, aphids, scale, mealybug, psyllid, and lace bug. Each tablet contains 200 g/kg imidacloprid and is placed in the soil at planting or near established plants, delivering fertiliser and insecticide directly to the roots. Suitable for containerised and in-ground plants. Apply one tablet per metre of plant height. Available in 300 and 1,200 tablet packs.





ECO-OIL ORGANIC INSECTICIDE/MITICIDE

PRODUCT CODE

E0500 500ml	E0001 1L	E0005 5L	E0020 20L
-----------------------	--------------------	--------------------	---------------------



Eco-Oil is a non-toxic botanical oil-based miticide and insecticide effective against Two-Spotted Mite, Aphids, Whitefly, Citrus Leafminer, and Scale. Its specially formulated essential oils penetrate insect exoskeletons and breathing parts, causing carbon dioxide poisoning. This physical mode of action prevents resistance buildup, while also acting as a mild repellent and destroying insect eggs to reduce reinfestation.



WHITE OIL SPRAY AEROSOL

PRODUCT CODE

WOS400 400g

This horticultural spray controls a wide variety of insects on roses and ornamentals and doubles as a leaf gloss for indoor plants. It contains 150g/L petroleum oil and can be used year-round, but should be avoided during the heat of the day to prevent leaf burn.





SILVEREYE™ ANTI-BIRDNETTING

Silvereye™ Anti-Bird Netting is premium-quality knitted polyethylene netting designed to protect valuable fruit crops from bird damage. Made from industrial-grade HDPE monofilament, it offers exceptional durability and comes with a 10-year UV breakdown guarantee. Available in a range of stocked sizes, with custom sizing available on request, Silvereye™ is a reliable long-term solution for safeguarding your investment.

SILVEREYE™ ECONONET

The Silvereye™ Econonet range offers a lightweight, cost-effective bird netting solution ideal for residential and light commercial use. Available in both black and white, Econonet features a 16mm hexagonal mesh crafted from durable, UV-stabilised polyethylene, backed by a 10-year UV guarantee. Each net is easy to install, and comes in a variety of pre-pack sizes to suit gardens, orchards, or small-scale crops. Custom sizing is also available. Silvereye Econonet provides reliable protection from bird damage while remaining an affordable, user-friendly choice.

PRODUCT CODE

GSKNBDNET5005W 5mx5m, White	GSKNBDNET5005B 5mx5m, Black
GSKNBDNET5010W 5mx10m, White	GSKNBDNET5010B 5mx10m, Black
GSKNBDNET1010W 10mx10m, White	GSKNBDNET1010B 10mx10m, Black
SBN5100WK33 5mx100m, White	SBN5100BK33 5mx100m, Black



SILVEREYE ULTRANET™

Silvereye Ultranet™ is a durable, heavy-duty 45gsm knitted bird net designed for long-term commercial use. Its robust construction helps prevent accidental tearing, saving time and hassle during installation and use. With a 15x15mm diamond mesh, Ultranet™ is available in black and white, and features contrasting centre and side stripes for easier setup. All sizes are packaged for quick deployment straight from the bale.

PRODUCT CODE

SBN13100WK45 13x100m, White	SBN10100BK45 10x100m, Black
SBN13150WK45 13x150m, White	SBN10150BK45 10x150m, Black
SBN13200WK45 13x200m White	SBN10200BK45 10x200m, Black
SBN15150WK45 15x150m, White	SBN13100BK45 13x100m, Black
	SBN13150BK45 13x150m, Black
	SBN13200BK45 13x200m, Black
	SBN15150BK45 15x150m, Black



INSECT NETTING

PRODUCT CODE

IN285 2.8m x 5m, 45gsm	IN28100 2.8m x 100m, 45gsm
----------------------------------	--------------------------------------

UV-stabilised 45gsm woven insect netting with 2mm mesh and 20% shade factor. Available as a 2.89m x 100m roll or a 2.89m x 5m folded sheet for draping over crops or frames to exclude insects.





WEED IDENTIFICATION CHART



Caltrop

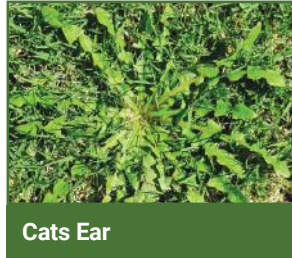

Cats Ear



Bindi



Buffalo Grass



Creeping Oxalis



Crowsfoot Grass



Couch Grass

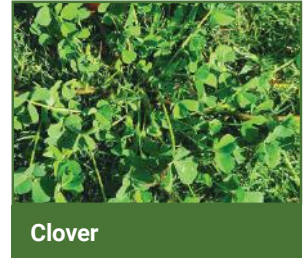

Clover



Dandelion



Doublegee



Fleabane



Flickweed



Guildford Grass



Kikuyu Grass



Mullumbimby Couch



Nutgrass

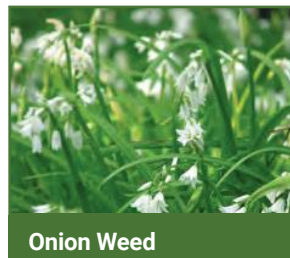

Onion Weed



Parramatta Grass



Paspalum

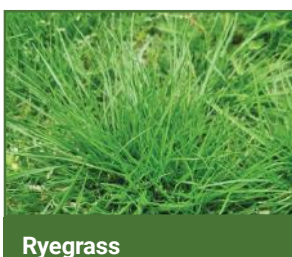

Ryegrass

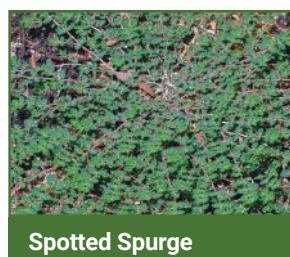

Spotted Spurge



Summer Grass

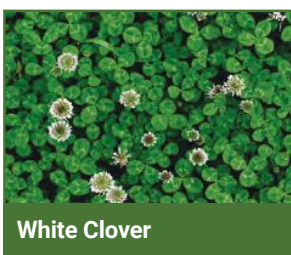

White Clover



Winter Grass



Wire Weed



PEST IDENTIFICATION CHART



African Black Beetle



Ants



Aphids



Armyworm



Billbug



Brown Scale



Sandgroper / Mole Cricket



Chilli Thrip



Fungus Gnat



Grasshopper



Snail / Slug



House Cricket



Locust



Mealy Bug



Spider Mite



Mediterranean Fruit Fly



Millipede



Psyllid



Sting Nematode



Termites / White Ants



White Wax Scale



Whitefly



SECTION 10

PRUNING TOOLS



VOLPI ELECTRONIC PRUNER

PRODUCT CODE

KV220

Weight: 740g | Cut Capacity: 22mm | Length: 27cm

Volpi's KV220 Cordless Scissors offer a lightweight, battery-powered alternative to manual pruning. Featuring integrated lithium battery technology and durable steel blades, they provide effortless cutting for small shrubs and ornamental plants—perfect for light pruning tasks around the garden.



VOLPI ELECTRONIC PRUNER

PRODUCT CODE

KV310

Weight: 710g | Cut Capacity: 30mm | Length: 28cm

The Volpi KV310 Powercut Cordless Scissors are fast, powerful, and lightweight—perfect for professional pruning in vineyards, orchards, gardens, and parks. Designed for efficiency and ease of use, they deliver reliable performance for demanding agricultural and landscaping tasks.



VOLPI ELECTRONIC PRUNER

PRODUCT CODE

KV390

Weight: 870g | Cut Capacity: 40mm | Length: 30cm

The Volpi KV390 is the latest cordless electronic pruner from VOLPI ORIGINALE, featuring a rechargeable lithium battery and progressive cutting action for high performance. Equipped with steel and Teflon-coated blades and three adjustable opening positions, it's ideal for pruning in parks, gardens, agriculture, and a variety of other applications.



VOLPI BATTERY POLE PRUNER

PRODUCT CODE

KV201

Weight: 1.8kg | Cut Capacity: 38mm | Length: 200cm

The VOLPI ORIGINALE cordless pole pruners are ideal for high-reach pruning with a 38 mm Teflon-coated blade and 200 cm length. Lightweight (1.3–1.8 kg) with a brushless motor, they reduce fatigue and deliver pro-level performance. Includes two lithium batteries, charger, and carry bag.



VOLPI BATTERY TELESCOPIC CHAINSAW

PRODUCT CODE

KVS8000P

Weight: 4kg | Cut Capacity: 160mm | Length: 170-250cm | Bar Length: 8"

The VOLPI ORIGINALE KVS8000P electronic pole chainsaw 170cm-250cm is designed for safe and efficient high-reach pruning. It features an 8" bar with protective cover, double safety switch, ergonomic handle with guard, and an adjustable head. The telescopic pole and automatic chain lubrication ensure ease and precision for elevated pruning tasks.



VOLPI BATTERY TELESCOPIC CHAINSAW

PRODUCT CODE

KVS7100P

Weight: 3kg | Cut Capacity: 160mm | Length: 250-350cm | Bar Length: 8"

The VOLPI ORIGINALE KVS7100P is a practical, lightweight pole chainsaw 250cm-350cm featuring an 8" bar with 1/4" chain and protective cover. It includes an integrated, visible oil tank with automatic, adjustable chain lubrication for efficient high-reach pruning.





ARS SHORT NOSE FRUIT SNIP

PRODUCT CODE

310T

Weight: 90g | Cut Capacity: 10mm | Length: 16cm

These snips long blades make it ideal for detailed cutting in vines and other horticultural applications. Blades are stainless steel to help prevent the spread of disease and have extra hardening for long life.



ARS CURVED NOSE FRUIT SNIP

PRODUCT CODE

310D

Weight: 90g | Cut Capacity: 10mm | Length: 16cm

This specialized fruit snip features upward-curved blades to prevent accidental puncturing and ensure clean, close cuts. Made from all-steel construction for durability and professional use.



ARS LONG NOSE FRUIT SNIP

PRODUCT CODE

SE45

Weight: 85g | Cut Capacity: 10mm | Length: 18cm

These snips feature long, stainless steel blades ideal for precise cutting in vines and horticultural tasks. The blades are hardened for extended durability and help prevent disease spread.



ARS LONG NOSE FRUIT SNIP

PRODUCT CODE

300L

Weight: 110g | Cut Capacity: 10cm | Length: 19cm

This tool features long, pointed blades ideal for picking and trimming table grapes. It includes strong, comfortable handles and a securely fitted coil spring for reliable use.



CYCLONE FLORAL SNIP

PRODUCT CODE

C660597

Weight: 90g | Cut Capacity: 8mm | Length: 19cm

The Cyclone Floral Snip is ideal for precision tasks like deadheading, light pruning, and harvesting flowers or herbs. Its fine stainless steel blades and ergonomic handle ensure clean, comfortable cuts—even during extended use. Perfect for garden, greenhouse, or indoor plant care.



CORONA PROFESSIONAL BYPASS SECATEURS

PRODUCT CODE

CBP4250

Weight: 300g | Cut Capacity: 25cm | Length: 21cm

Professional-grade secateurs featuring lightweight forged aluminium handles and a high-carbon steel blade and hook. Designed for durability and precision, they cut branches up to 25 mm in diameter with ease.



CORONA ERGONOMIC BYPASS SECATEURS

PRODUCT CODE

CBP4180

Weight: 300g | Cut Capacity: 16mm | Length: 21cm

Lightweight general-purpose pruner with ergonomic, reinforced nylon handles. Ideal for everyday use, it cleanly cuts branches up to 20 mm in diameter.





CORONA ROLL HANDLE SECATEURS

PRODUCT CODE

CBP4840

Weight: 260g | Cut Capacity: 25mm | Length: 22cm

Designed to reduce hand fatigue, this professional pruner features a rolling handle and replaceable high-carbon steel blades that cut up to 25 mm. Lightweight forged aluminium construction ensures strength and durability.



FELCO ROLL HANDLE SECATEURS

PRODUCT CODE

FELCO7

Weight: 315g | Cut Capacity: 25mm | Length: 22cm
Right handed

FELCO10

Weight: 315g | Cut Capacity: 25mm | Length: 22cm
Left handed

A high-performance pruner with an angled cutting head and unique revolving handle that distributes pressure evenly across the hand—ideal for intensive, prolonged pruning tasks.



FELCO COMPACT SECATEURS

PRODUCT CODE

FELCO6

Weight: 215g | Cut Capacity: 20mm | Length: 20cm

The Felco 6 is a compact, high-quality secateur with a tapered cutting head, ideal for smaller hands. Suitable for general to intensive pruning.



FELCO CLASSIC SECATEURS

PRODUCT CODE

FELCO2

Weight: 250g | Cut Capacity: 25mm | Length: 25mm

This classic Felco pruner features stainless steel blades and handles, with a rubber shock absorber and cushion for wrist protection. Ideal for general to intensive pruning.



FELCO NEW-GENERATION SECATEURS

PRODUCT CODE

FELCO11

Weight: 240g | Cut Capacity: 25mm | Length: 21cm

This ergonomic Felco secateur features a slimmer cutting head profile and an easy-to-replace anvil blade, offering the same reliability as the Felco 2. Ideal for general to intensive pruning.



FELCO CUT AND HOLD PRUNING SHEAR

PRODUCT CODE

FELCO100

Weight: 255g | Cut Capacity: 25mm | Length: 25cm

Ideal for rose and flower pruning, the FELCO 100 picking snips are based on the popular FELCO 11 shears and specially designed to prevent dropped stems—perfect for precise flower harvesting.



FELCO ERGONOMIC SECATEURS

PRODUCT CODE

FELCO8

Weight: 250g | Cut Capacity: 25mm | Length: 21cm
right handed

FELCO9

Weight: 250g | Cut Capacity: 25mm | Length: 21cm
left handed

An ergonomically designed secateur with an offset cutting head for optimal pruning efficiency and reduced hand fatigue—ideal for prolonged use.





FELCO STANDARD SECATEURS

PRODUCT CODE

FELCO4

Weight: 230g | Cut Capacity: 25mm | Length: 21cm

A standard model of reliable Felco secateur with plastic-coated handles and fully replaceable parts—ideal for general garden pruning tasks.



FELCO BASIC SECATEURS

PRODUCT CODE

FELCO5

Weight: 315g | Cut Capacity: 25mm | Length: 23cm

The Felco 5 Basic Secateur features durable pressed steel handles and a tapered cutting head, making it ideal for everyday garden maintenance.



ARS PROFESSIONAL ROLL HANDLE SECATEUR

PRODUCT CODE

VS8R

Weight: 275g | Cut Capacity: 22mm | Length: 20cm

Top-of-the-range professional secateur featuring a revolving handle to reduce hand fatigue by evenly distributing pressure. Built with lightweight alloy grips and hard-chromed blades for exceptional durability and long service life.



ARS ROLL PROFESSIONAL HANDLE SECATEUR

PRODUCT CODE

VS9R

Weight: 305g | Cut Capacity: 25cm | Length: 23cm

Premium secateur with a revolving handle for reduced hand strain and improved comfort. Features lightweight alloy grips and hard-chromed blades for exceptional durability and long-lasting performance.



ARS PROFESSIONAL BYPASS SECATEURS

PRODUCT CODE

VS8Z

Weight: 220g | Cut Capacity: 22mm | Length: 20cm

Top-tier professional secateurs featuring lightweight alloy handles and hard-chromed blades with a sap groove for durability and clean cutting. Designed for long-lasting performance and ease of use.



ARS PROFESSIONAL BYPASS SECATEURS

PRODUCT CODE

VS9Z

Weight: 255g | Cut Capacity: 25mm | Length: 25cm

Top-of-the-range professional secateurs with durable, lightweight alloy handles and hard-chromed blades featuring a sap groove for cleaner cuts and extended blade life.



WOLF BASIC PLUS BYPASS SECATEUR

PRODUCT CODE

RR1500

Weight: 195g | Cut Capacity: 18mm | Length: 19.5cm

The WOLF-Garten® Basic Plus Bypass Secateurs offer energy-saving leverage, making them ideal for trimming flowers and ornamental plants on balconies, in yards, and throughout the garden.





WOLF-GARTEN COMFORT BYPASS SECATEUR

PRODUCT CODE

RR2500

Weight: 200g | Cut Capacity: 20mm | Length: 20cm

Quality German-made secateurs featuring ergonomic handles for comfort and non-stick Teflon-coated blades with a 22mm cutting capacity. Designed with a hidden spring for added protection and durability.



WOLF-GARTEN PREMIUM PLUS BYPASS SECATEUR

PRODUCT CODE

RR4000

Weight: 210g | Cut Capacity: 22mm | Length: 20cm

Premium German-made secateurs with ergonomic handles for comfort, non-stick Teflon-coated blades for smooth cutting (up to 22 mm), and a hidden spring for enhanced durability and protection.

WOLF-GARTEN PROFESSIONAL BYPASS SECATEUR

PRODUCT CODE

RR5000

Weight: 305g | Cut Capacity: 25mm | Length: 22cm

High-quality German-made secateurs featuring ergonomic handles for comfort, non-stick Teflon-coated blades with a 22 mm cutting capacity, and a protected hidden spring for added durability.



WOLF-GARTEN BYPASS LOPPER

PRODUCT CODE

RR630

Weight: 845g | Cut Capacity: 35mm | Length: 64cm

The 'Comfort Style' Bypass Lopper features lightweight yet strong oval handles with ergonomic grips, offering excellent control and comfort. With a 630 mm total length and a cutting capacity of up to 35 mm, it's ideal for a wide range of pruning tasks.

WOLF-GARTEN POWERCUT TELESCOPIC BYPASS LOPPER

PRODUCT CODE

RR900T

Weight: 1555g | Cut Capacity: 50mm | Length: 68-92cm

This high-quality bypass lopper features extendable handles for added reach and versatility. Its advanced power transmission system multiplies cutting force by up to 4 times, while ergonomic grips and lightweight anodised handles provide maximum comfort and ease of use.





WOLF-GARTEN POWERCUT BYPASS LOPPER

PRODUCT CODE

RR750

Weight: 845g | Cut Capacity: 45mm | Length: 75cm

This lopper is designed in Germany for exceptional cutting performance and comfort. Its unique power transmission system multiplies your cutting force by up to three times, making light work of tough, thick branches. With a 750mm handle length and a 45mm cutting capacity, it's ideal for heavy-duty pruning tasks.



WOLF-GARTEN POWERCUT TELESCOPIC ANVIL LOPPER

PRODUCT CODE

RS900T

Weight: 1565g | Cut Capacity: 50mm | Length: 69-93cm

This quality anvil lopper features extendable handles (65–90 cm) and a unique power transmission system that multiplies cutting force up to 4x. With a 50 mm cutting capacity, ergonomic grips, and lightweight anodised handles, it delivers comfort and versatility for tough pruning tasks.



WOLF-GARTEN POWERCUT ANVIL LOPPER

PRODUCT CODE

RS750

Weight: 1390g | Cut Capacity: 45mm | Length: 79cm

The Wolf-Garten PowerCut Lopper features a unique power transmission system that triples cutting force for effortless pruning. Lightweight yet strong anodised aluminium handles and ergonomic grips ensure maximum comfort during use. Made in Germany for quality and performance.



FELCO HEAVY DUTY LOPPER

PRODUCT CODE

FELCO22

Weight: 2100g | Cut Capacity: 50mm | Length: 85cm

Heavy-duty bypass lopper with a wide-opening, durable cutting head. Features forged aluminium handles with plastic coating for strength and comfort. Ideal for tough pruning tasks.



FELCO EASY-CUT CURVED HEAD LOPPER ALUMINIUM

PRODUCT CODE

F210A-60

Weight: 770g | Cut Capacity: 35mm | Length: 60cm

The FELCO Easy-Cut Curved Head Lopper offers precise, effortless pruning with its curved cutting head and hardened steel blade. Lightweight aluminum handles feature non-slip grips and shock absorbers for comfort, while the screw-mounted anvil blade ensures clean cuts. Durable and easily adjustable—perfect for all pruning tasks.



FELCO TWO HANDED PRUNING BYPASS LOPPER

PRODUCT CODE

FELCO220

Weight: 1325g | Cut Capacity: 40mm | Length: 82cm

This high-resistance bypass lopper features rigid tubular aluminum alloy handles and hardened steel blades for clean, precise cuts. Its optimised lever system ensures effortless pruning, while the durable cutting adjustment offers long-lasting performance.





FELCO STRAIGHT BLADE ANVIL LOPPER

PRODUCT CODE

FELC0230

Weight: 1170g | Cut Capacity: 40mm | Length: 80cm

This heavy-duty anvil lopper features high-resistance tubular aluminum alloy handles, a straight tempered steel blade, and a replaceable forged aluminum anvil for clean, precise cuts. Its optimised lever system ensures effortless cutting with durable, easy adjustments.

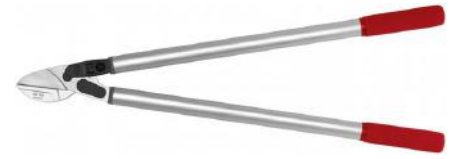

FELCO CURVED BLADE ANVIL LOPPER

PRODUCT CODE

FELC0231

Weight: 1180g | Cut Capacity: 40mm | Length: 80cm

This durable pruning lopper features high-resistance tubular aluminum alloy handles, a curved tempered steel blade, and a replaceable forged aluminum anvil for clean, precise cuts. Its optimised lever system ensures effortless cutting and long-lasting adjustment.

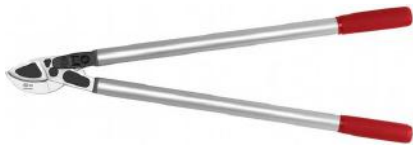

ARS PROFESSIONAL HEAVY DUTY LOPPER

PRODUCT CODE

LP40L

Weight: 1750g | Cut Capacity: 50mm | Length: 81cm

These heavy-duty loppers from ARS feature high carbon steel blades with a non-stick Teflon coating and strong yet lightweight alloy handles—built for rigorous, professional use in the field.



ARS PROFESSIONAL BYPASS LOPPER

PRODUCT CODE

LPB20S

Weight: 830g | Cut Capacity: 30mm | Length: 48cm

Features a shallow, high-carbon steel blade and hook, specially hardened and sharpened for durability. The counter blade includes a sap groove, and the strong yet lightweight handles have rugged, comfortable grips.



ARS PROFESSIONAL BYPASS LOPPER

PRODUCT CODE

LPB30S

Weight: 860g | Cut Capacity: 34mm | Length: 49cm

Offers the same features as the LP20S, but with a deeper hook and wider blade for increased cutting capacity and improved grip to prevent branches from slipping during use.



ARS PROFESSIONAL BYPASS LOPPER

PRODUCT CODE

LPB30M

Weight: 980g | Cut Capacity: 36mm | Length: 63cm

A longer version of the LPB30S, designed to make lopping easier in hard-to-reach areas.





ARS PROFESSIONAL BYPASS LOPPER

PRODUCT CODE

LPB30L

Weight: 1100g | Cut Capacity: 36mm | Length: 79cm

The ARS Professional Bypass Lopper features a shallow blade and hook crafted from high-carbon tool steel, specially hardened and precision-sharpened for clean, efficient cuts. The counter blade includes a sap groove to reduce sticking during use, while the lightweight yet strong handles are fitted with rugged, ergonomic grips for comfortable extended use. Designed for professional performance and durability.



BAHCO ORCHARD LOPPER

PRODUCT CODE

P160SL90

Weight: 1200g | Cut Capacity: 45mm | Length: 90cm

Ideal for overhead pruning, these loppers feature strong oval tubular aluminium handles for lightweight durability. The deeply hooked counter blade secures branches during cutting. Spare parts available.



BAHCO BYPASS LOPPER

PRODUCT CODE

P1660F

Weight: 970g | Cut Capacity: 30mm | Length: 59cm

This model features tubular steel handles like the P1450, making it ideal for vineyard and rose pruning, but includes a larger blade opening and deep hook for handling heavier cuts with ease.



BAHCO ULTRA HEAVY DUTY LOPPER

PRODUCT CODE

P1980F

Weight: 1720g | Cut Capacity: 50mm | Length: 79cm

The largest and most robust Bahco bypass lopper, designed with large blades and a wide blade opening to handle bigger cuts with ease. Features fully replaceable parts for long-term durability.



BAHCO ORCHARD LOPPER

PRODUCT CODE

P160SL75

Weight: 1200g | Cut Capacity: 45mm | Length: 75cm

Designed for overhead pruning, these lightweight loppers feature strong oval tubular aluminium handles for reduced weight and maximum strength. The deeply hooked counter blade securely grips branches. Spare parts available.





BAHCO SUPER LIGHT LOPPER

PRODUCT CODE

P116SL40

Weight: 660g | Cut Capacity: 30mm | Length: 42cm

These super-light loppers are built for cutting tough wood with ease and offer a large cutting capacity. All parts are fully replaceable for long-term use.



BAHCO SUPER LIGHT LOPPER

PRODUCT CODE

P114SL50

Weight: 670g | Cut Capacity: 36mm | Length: 48cm

This lopper features blades with a shallower hook, making it lighter and easier to handle—ideal for quick, efficient pruning.



FISKARS BYPASS LOPPER L72

PRODUCT CODE

F112200

Weight: 480g | Cut Capacity: 30mm | Length: 46cm

Heavy-duty lopper with Powergear™ cutting action and 38mm capacity. Features a Xylan-coated blade, stainless steel hook, replaceable blade, and 545mm overall length. Backed by a lifetime warranty.



FISKARS BYPASS LOPPER L76

PRODUCT CODE

F112300

Weight: 550g | Cut Capacity: 28mm | Length: 56cm

Heavy-duty lopper made in Finland with a 55mm cutting capacity. Features Powergear™ cutting action, a Xylan-coated blade, stainless steel hook, and replaceable blade. Length: 557mm. Backed by a lifetime warranty.



FISKARS POWERGEAR BYPASS LOPPER LX98

PRODUCT CODE

F112590

Weight: 140g | Cut Capacity: 50mm | Length: 81cm

The new ARS high-performance anvil lopper from Japan features a forged cutting and counter blade, ultra-light handles, and ergonomic hand grips—delivering exceptional cutting power and comfort for professional use.



CYCLONE RATCHET TELESCOPIC BYPASS LOPPER

PRODUCT CODE

C660535

Weight: 255g | Cut Capacity: 40mm | Length: 76cm

The Cyclone Telescopic Ratchet Bypass Lopper is perfect for cutting live green branches. Its ratchet mechanism delivers extra cutting power in stages, reducing user fatigue and making tough jobs easier.





SPEAR & JACKSON TELESCOPIC BYPASS GEARED LOPPER

PRODUCT CODE

SJ8090RS

Weight: 1500g | Cut Capacity: 40mm | Length: 69-112cm

Heavy-duty ratchet lopper from Spear & Jackson with hardened carbon steel blades and PTFE coating. Lightweight aluminium handles extend from 70–90cm with non-slip grips. Cuts branches up to 60mm. Weight: 1980g.



ARS HEDGE SHEAR

PRODUCT CODE

K800R

Weight: 550g | Cut Capacity: 6mm | Length: 50cm

Lightweight yet strong, this 50cm hedge shear features thin blades ideal for precise trimming and topiary work. Weighing just 550g, it offers excellent control and versatility for detailed hedge shaping.

ARS PRECISION HEDGE SHEAR

PRODUCT CODE

KR1000

Weight: 780g | Cut Capacity: 6mm | Length: 66cm

This strong yet lightweight 65.3cm hedge shear features thin, versatile blades ideal for topiary and precision trimming. Weighing just 700g, it offers excellent control for detailed shaping tasks.



WOLF HEDGE SHEAR

PRODUCT CODE

HSB

Weight: 600g | Length: 6mm | Length: 41cm

This 53cm hedge shear combines comfort and efficiency with its lightweight, sturdy head and strong oval-shaped aluminium handles. The Teflon-coated, non-stick curved blades ensure clean, precise cuts. Weighs 900g.

WOLF-GARTEN GEARED HEDGE SHEAR

PRODUCT CODE

HS-G

Weight: 1100g | Cut Capacity: 10mm | Length: 60cm

This 60cm hedge shear features wave-shaped, double-edged Teflon-coated blades and an integrated mechanical gear system that reduces cutting effort by 40%. Weighs 1100g.



WOLF-GARTEN TELESCOPIC HEDGE SHEAR

PRODUCT CODE

HS1000T

Weight: 1480g | Cut Capacity: 10mm | Length: 78-104cm

This versatile Wolf-Garten extendable hedge shear features telescopic oval aluminum handles (77–100 cm), fine blade adjustment, built-in branch cutter, and rubber buffers for comfort—ideal for trimming tall hedges. Weighs 1,450g.



WOLF-GARTEN GRASS SHEAR

PRODUCT CODE

RI-T

Weight: 290g | Cut Capacity: 6mm | Length: 32cm

High-quality grass shears from Wolf-Garten, Germany, with 180° swiveling blades for precise lawn edge trimming and hard-to-reach areas. Ideal for bonsai and small topiary work.



BAHCO TELESCOPIC HEDGE SHEAR

PRODUCT CODE

PG57F

Weight: 1350g | Cut Capacity: 10mm | Length: 81-104cm

This new Bahco hedge shear features telescopic handles that extend from 850mm to 1050mm, offering added reach for taller hedges. Weighs 1450g for balanced handling.



BAHCO LONG HANDLE HEDGE SHEAR

PRODUCT CODE

P51HSL

Weight: 1150g | Cut Capacity: 10mm | Length: 75cm

This hedge shear features long, durable steel handles and straight blades with notches to prevent branch slippage—ideal for trimming tall hedges. Includes neoprene buffers. Length: 75cm. Weight: 1150g.



BAHCO PROFESSIONAL HEDGE SHEAR

PRODUCT CODE

P51F

Weight: 1050g | Cut Capacity: 10mm | Length: 58cm

Extremely strong hedge shear with unbreakable steel handles and long straight blades featuring notches to prevent slippage and cut small branches. Includes neoprene buffers. Length: 57cm.



CYCLONE HEDGE SHEAR

PRODUCT CODE

C660474

Weight: 900g | Cut Capacity: 10mm | Length: 59cm

This Cyclone hedge shear features heat-treated, Teflon-coated wavy blades for clean cuts, corrosion resistance, and lasting durability. Its compound lever boosts cutting power, while strong aluminium handles reduce fatigue.



CYCLONE TELESCOPIC HEDGE SHEAR

PRODUCT CODE

C658082

Weight: 1100g | Cut Capacity: 10mm | Length: 65-85cm

This Cyclone hedge shear features heat-treated, Teflon-coated wavy blades for clean cuts, durability, and corrosion resistance. A compound lever boosts cutting power, while telescopic aluminium handles extend for greater reach in hard-to-access areas.





BAHCO LAWN SHEAR

PRODUCT CODE

P74

Weight: 1670g | Length: 110cm

This Bahco lawn shear from France features Teflon-coated blades for trimming hard-to-reach lawn areas. It has strong, round tubular steel handles measuring 90cm for extended reach and durability.



BAHCO BORDER SHEAR

PRODUCT CODE

P75

Weight: 1670g | Length: 101cm

This edge shear features vertical blades for precise hand trimming of lawn edges. It comes with strong, durable 90cm tubular steel handles for comfortable extended use.



FELCO 12CM FOLDING SAW

PRODUCT CODE

FE601

Weight: 140g | Blade Length: 12cm | Saw Length: 18-30cm

FELCO's folding saw range is built for professionals but perfect for home gardeners too. With blade shapes suited to tasks like pruning, landscaping, and arboriculture, they feature chrome-plated, impulse-hardened teeth for smooth, durable cutting. A soft-touch handle offers an ergonomic grip, and all models suit both right- and left-handed users.



FELCO 16CM FOLDING SAW

PRODUCT CODE

FE602

Weight: 160g | Blade Length: 16mm | Saw Length: 21-36cm

FELCO's folding saw range is designed for professionals and home gardeners alike. Featuring a variety of blade geometries for tasks like vineyard work, landscaping, and general pruning, these saws have impulse-hardened, chrome-plated teeth for durability and smooth cutting. A soft-touch handle ensures a secure, ergonomic grip, and all models suit both right- and left-handed users.



FELCO 20CM FOLDING SAW

PRODUCT CODE

FE603

Weight: 215g | Blade Length: 20cm | Saw Length: 26-45cm

FELCO folding saws are designed for professional and home use, with blade geometries tailored for vineyard, arboriculture, landscaping, and general pruning. Chrome-plated, impulse-hardened teeth ensure smooth, long-lasting cutting, while optimized tooth design aids chip clearance. A soft-touch handle offers a secure, ergonomic grip, and all models suit both left- and right-handed users.



FELCO 25CM FOLDING SAW

PRODUCT CODE

FE604

Weight: 250g | Blade Length: 25cm | Saw Length: 30-53cm

FELCO's range of folding saws is crafted for professionals but ideal for garden pruning as well. Featuring various blade geometries for tasks like vineyard, arborist, or landscape use, these saws offer impulse-hardened teeth for long-lasting sharpness, chrome plating for reduced friction, and optimized chip evacuation. A soft-touch handle ensures ergonomic comfort, and all models suit both right- and left-handed users.





FELCO 16CM FOLDING SAW

PRODUCT CODE

FE600

Weight: 155g | Blade Length: 16cm | Saw Length: 21-35cm

The Felco 600 Folding Saw (16cm) is a compact, professional-grade pruning saw ideal for smooth pull-stroke cutting. Its chrome-plated, impulse-hardened blade ensures durability and long-lasting sharpness. With a lightweight design, ergonomic non-slip handle, and safe folding mechanism, it's perfect for landscapers, arborists, and gardeners.



FELCO SHEATHED PRUNING SAW

PRODUCT CODE

C660474

Weight: 220g | Blade Length: 33cm | Saw Length: 51cm

The Felco Sheathed Pruning Saw features a 33cm impulse-hardened, chrome-plated blade for smooth pull-stroke cutting. Its ergonomic, non-slip handle ensures comfort and control, while the included sheath with a detachable belt loop suits both right- and left-handed users for convenient access.



CORONA 25CM PRUNING SAW

PRODUCT CODE

CRS7360

Weight: 225g | Blade Length: 25cm | Saw Length: 37cm

Ideal for cutting medium to large branches, this saw features a 25cm straight blade with 3-sided impulse-hardened Razor Teeth and a self-cleaning raker tooth pattern. The co-moulded ergonomic handle ensures comfortable use.



CORONA 35CM CURVED PRUNING SAW

PRODUCT CODE

CRS7395

Weight: 270g | Blade Length: 36cm | Saw Length: 54cm

Perfect for medium to large branches, this saw features a 35cm curved blade with 3-sided impulse-hardened Razor Teeth and a self-cleaning raker tooth pattern. The curved design allows for faster cutting, while the co-moulded ergonomic handle ensures comfortable use.



CORONA 18CM FOLDING SAW

PRODUCT CODE

CRS7245

Weight: 200g | Blade Length: 18cm | Saw Length: 22-38cm

Ideal for small to medium branches, this folding saw features a 17.5cm curved blade with 3-sided impulse-hardened Razor Teeth and a self-cleaning raker tooth pattern. The curved design ensures faster cutting, while the co-moulded ergonomic handle provides comfort during use.



ARS CURVED FOLDING PRUNING SAW

PRODUCT CODE

GR17

Weight: 170g | Blade Length: 18cm | Saw Length: 23-38cm

ARS Folding Pruning Saw – 17cm Curved: A compact, pocket-sized folding saw featuring a 17cm hard chrome blade with turbo cut teeth for fast, efficient sawing. Ideal for quick pruning jobs on the go.





ARS STRAIGHT FOLDING PRUNING SAW

PRODUCT CODE

ARZ17

Weight: 170g | Blade Length: 18cm | Saw Length: 23-38cm

ARS Folding Pruning Saw – 17cm Straight: A compact, pocket-friendly folding saw with a 17cm hard chrome straight blade and turbo cut teeth for fast, smooth cutting. Perfect for precise pruning tasks on the go.



ARS 32CM CURVED PRUNING SAW

PRODUCT CODE

CT32EN

Weight: 260g | Blade Length: 32cm | Saw Length: 48cm

ARS Curved Pruning Saw – 32cm: Features a large, curved 32cm Turbo-cut blade for rapid, efficient cutting. The ergonomically redesigned handle with a rubber-coated grip ensures comfort and slip resistance during use.



BAHCO 18CM FOLDING SAW

PRODUCT CODE

396HP

Weight: 190g | Blade Length: 18cm | Saw Length: 23-40cm

Compact Folding Pruning Saw – 18cm: Features an 18cm blade with hardened pruning teeth and a secure locking mechanism. The rubberised grip ensures comfort and control during use.



BAHCO 37CM PRUNING SAW

PRODUCT CODE

3396T

Weight: 220g | Blade Length: 37cm | Saw Length: 52cm

BAHCO 37cm Pruning Saw: A versatile saw with a 37cm blade that can be used by hand or mounted on a pole for high-reach pruning. Ideal for professional and general garden use.



BAHCO TELESCOPIC POLE

PRODUCT CODE

AP5M

Length: 2m-5m

Triple-extension aluminium pole with secure twist-lock mechanism. Extends up to 5 metres for high-reach pruning and maintenance tasks.



BAHCO 37CM POLEMOUNT SAW

PRODUCT CODE

3836T

Weight: 220g | Blade Length: 37cm | Saw Length: 52cm

Durable pruning saw with a 37cm curved, hardened-tooth blade for long-lasting sharpness. Features a steel handle designed to mount onto round poles for extended reach.



BAHCO 53CM TRIANGULAR BOWSAW

PRODUCT CODE

BA3322151

Weight: 680g | Blade Length: 53cm | Saw Length: 66cm

FORCE range pruning saw with a 53cm triangular frame and protective plastic knuckle guard. The narrow tip allows easy access to tight or awkward spaces, offering precision and safety during use.





BAHCO 60CM BOWSAW

PRODUCT CODE

BA102451

Weight: 750g | Blade Length: 60cm | Saw Length: 74cm

BAHCO 60cm Bowsaw from the FORCE range features a strong, lightweight steel frame with a knuckle-guard ERGO™ handle for comfort and safety. It includes a high-tension mechanism for straighter cuts and comes with a drywood blade. Ideal for professional use.



ARS 18CM ARBORIST PRUNING SAW

PRODUCT CODE

CAM18PRO

Weight: 150g | Blade Length: 18cm | Saw Length: 36cm

Compact and powerful, the CAM18PRO is ideal for precision pruning in tight spaces. Featuring a razor-sharp 18cm pull-cut blade made from high-carbon tool steel, it ensures clean, efficient cuts every time. The rubberized grip provides exceptional comfort and control, while the reversible scabbard with safety lock and insert rollers allows for safe, versatile storage. Belt or leg mountable, it's a professional-grade tool in a compact size.



ARS 24CM ARBORIST PRUNING SAW

PRODUCT CODE

CAM24PRO

Weight: 160g | Blade Length: 24cm | Saw Length: 42cm

The CAM24PRO strikes the perfect balance between reach and control. Its 24cm high-carbon steel blade delivers fast, clean pull-cuts, making it ideal for general pruning tasks. With a comfortable rubberized grip and a reversible, locking scabbard featuring insert rollers, it's built for safe, all-day use. Mount it on your belt or secure it to your leg for convenience—this saw is made for serious gardeners and pros alike.



ARS 32CM ARBORIST PRUNING SAW

PRODUCT CODE

CT32PRO

Weight: 230g | Blade Length: 32cm | Saw Length: 48cm

Designed for heavy-duty pruning, the CT32PRO features a 32cm high-carbon steel blade for high-efficiency cutting of larger branches. The ergonomic handle with rubberized inserts ensures a comfortable and firm grip, while the reversible safety-lock scabbard with insert rollers offers superior protection and ease of use. Suitable for belt or leg mounting, this top-tier saw is built for demanding professional use.



GREEN MOUNTAIN HIGH LIMB CHAIN SAW

PRODUCT CODE

GM214

High Limb Hand Operated Chain Saw is a versatile tool for trimming high branches safely from the ground. It features a patented 48" chain blade with bi-matic carbon steel cutters for smooth, efficient cutting as it's pulled back and forth. Equipped with two 25ft polypropylene ropes and a sandbag throwing weight for easy positioning, it cuts through most timber types and can be sharpened with a standard chainsaw file. Made in the USA.





ARS SUPER TURBO-CUT SAW

PRODUCT CODE

UV47

Weight: 495g | Blade Length: 47cm | Saw Length: 68cm

This versatile 50cm cutting head is designed for use with extension poles and features Super Turbocut teeth for fast, efficient cutting. It includes an integrated hook for removing cut branches and a bark cutter to prevent tearing, making it an essential tool for high-reach pruning tasks.



ARS TELESCOPIC POLE

PRODUCT CODE

EXP45

Weight: 1900g | Length: 1.8m-4.5m

EXP55

Weight: 2200g | Length: 2.1m-5.5m

The ARS Telescopic Pole is a well-designed, double-extension pruning pole that extends from 1.8m to 4.5m or 2.1m to 5.5m, depending on the model. Lightweight yet impressively rigid, it offers excellent control and reach for high pruning tasks.



ARS TWO HANDED LONG REACH LOPPER

PRODUCT CODE

AR18518

Weight: 1730g | Cut Capacity: 45mm | Length: 1.8m

The ARS Long Reach Pruner offers a revolutionary approach to high pruning, combining strength and precision in a lightweight design. The 1.8m long reach lopper allows you to make powerful cuts up to 3.6m off the ground and handles branches up to 40mm in diameter. Ideal for professional and home use where reach and control are essential.



SILKY GOMTARO HANDSAW

PRODUCT CODE

102-27

Weight: 240g | Blade Length: 27cm | Saw Length: 41cm

102-30

Weight: 240g | Blade Length: 30cm | Saw Length: 43cm

The Silky Gomtaro Handsaws, available in 270mm (102-27) and 300mm (102-30) blade lengths, are premium Japanese pruning tools ideal for both professionals and serious home gardeners. Designed to cut on the pull stroke, these saws feature high-carbon steel blades with impulse-hardened Mirai-Me teeth, delivering fast, clean cuts through medium to large branches with minimal effort. The large tooth configuration ensures efficient cutting performance, while the ergonomic GOM rubber handle provides a comfortable, non-slip grip during prolonged use. Each saw comes equipped with a new-style hold-fast scabbard, featuring a locking roller for secure, convenient storage and easy access in the field. Built for durability and ease of maintenance, all key components are replaceable, making the Gomtaro a reliable and long-lasting choice for general-purpose pruning tasks.



SILKY PROSENTI PRUNING SAW

PRODUCT CODE

108-30

Weight: 235g | Blade Length: 30cm | Saw Length: 43cm

Gomtaro Prosentì 300mm Handsaw – a versatile pruning saw ideal for the keen gardener. Featuring both large and fine teeth on a single blade, it offers flexibility for cutting through various branch sizes with ease and precision. Perfect for general garden use.





SILKY GOMTARO FINE TOOTH SAW

PRODUCT CODE

104-24

Weight: 210g | Blade Length: 24cm | Saw Length: 37cm

This 24cm pruning saw features impulse-hardened Mirai-Me teeth for long-lasting sharpness and exceptionally smooth cuts. The hollow-ground high-carbon steel blade reduces friction and resists rust with its special protective coating. A GOM rubber handle ensures a secure grip and minimizes vibration, making it ideal for fast, clean pruning with comfort and precision.



SILKY GOMTARO ROOT CUTTING SAW

PRODUCT CODE

153-24

Weight: 220g | Blade Length: 24cm | Saw Length: 37cm

The Gomtaro 240mm Root Cutting Handsaw is ideal for tough pruning tasks involving soil-covered timber, tree roots, or suckers. Designed for ground-level work, it features durable, impulse-hardened teeth and a robust blade that handles cutting through dirt and debris with ease. Perfect for gardeners needing reliable performance in challenging conditions.



SILKY ZUBAT PRUNING SAW - LARGE TOOTH

PRODUCT CODE

270-24

Weight: 280g | Blade Length: 24cm | Saw Length: 39cm

270-33

Weight: 310g | Blade Length: 33cm | Saw Length: 48cm

The Silky Zubat Large Tooth saws are premium Japanese curved pruning saws with full-tang construction for strength and balance. Available in 24cm, 30cm, and 33cm blade lengths, they feature impulse-hardened teeth for fast, clean pull-stroke cuts—ideal for arboriculture, forestry, and serious garden work.



270-30

Weight: 300g | Blade Length: 30cm | Saw Length: 45cm



SILKY SUGOI PRUNING SAW

PRODUCT CODE

390-36

Weight: 375g | Blade Length: 36cm | Saw Length: 57cm

The Silky Sugoi 360 is a heavy-duty curved hand saw designed for fast, efficient cutting of medium to large branches. Its 360mm alloy-steel blade offers a perfect balance of strength and flexibility, with specially designed low-friction teeth for smooth, rapid cuts. The ergonomic GOM rubber handle ensures a secure, comfortable grip, while the durable scabbard includes leg straps and a belt attachment for versatile carrying options.

SILKY TSURUGI PRUNING SAW

PRODUCT CODE

452-30

Weight: 230g | Blade Length: 30cm | Saw Length: 47cm

The Silky Tsurugi is a slim-profile pruning saw designed for precision work on small to medium branches. Ideal for arborists and professionals, it excels in tight spaces and thinning tasks, delivering clean, smooth cuts with its impulse-hardened, non-set teeth. The rubberized handle ensures comfort and control, while tool-free blade changes make maintenance quick and easy—perfect for detailed, accurate pruning.





SILKY BIGBOY 2000 FOLDING SAW

PRODUCT CODE

356-36

Weight: 455g | Blade Length: 36cm | Saw Length: 41-76cm

The Big Boy 360mm Large Folding Saw from Japan is a powerful, lightweight saw ideal for camping, bushcraft, and survival. With its large blade and aggressive teeth, it easily handles medium to large branches, offering exceptional cutting capacity in a compact folding design.



SILKY GOMBOY FOLDING SAW - STRAIGHT

PRODUCT CODE

121-21

Weight: 250g | Blade Length: 21cm | Saw Length: 24-45cm

121-24

Weight: 275g | Blade Length: 24cm | Saw Length: 27-50cm

121-30

Weight: 380g | Blade Length: 30cm | Saw Length: 33-62cm

With refined Japanese cutting technology, the Silky Gomboy is the #1 selling saw worldwide. Its precision-ground, medium teeth, straight blade and premium handle deliver outstanding performance and comfort across a range of tasks—from woodworking and camping to everyday yard work.



SILKY GOMBOY FOLDING SAW - CURVED

PRODUCT CODE

717-21

Weight: 250g | Blade Length: 21cm | Saw Length: 24-45cm

The Silky Gomboy Curved Folding Saw is a versatile, mid-sized tool perfect for general pruning, camping, and even light carpentry. Featuring a curved, medium-tooth blade for smooth, efficient cutting, it folds into a GOM rubber handle that offers excellent grip—even in wet conditions. Hollow-ground and taper-ground blade design reduces friction, while the special Silky steel resists rust and sap buildup.



SILKY POCKET BOY FOLDING SAW - FINE

PRODUCT CODE

342-17

Weight: 230g | Blade Length: 17cm | Saw Length: 21-37cm

The Silky PocketBoy 170mm Fine Tooth is a compact, lightweight folding saw designed for smooth, precise cuts. Featuring a rust-resistant, chrome-plated blade with impulse-hardened non-set teeth, it delivers efficient performance in a pocket-sized form. Ideal for hiking, pruning, or keeping in your glove box, it includes a non-slip rubber grip and a clear flip-lock case with belt clip.



SILKY POCKET BOY FOLDING SAW - MEDIUM

PRODUCT CODE

340-13

Weight: 180g | Blade Length: 13cm | Saw Length: 16-29cm

340-17

Weight: 230g | Blade Length: 17cm | Saw Length: 21-37cm

Manufactured in Japan by Silky Saws, the PocketBoy folding saw—nicknamed the “Little Giant”—packs big cutting power into a compact tool. Available in 130mm and 170mm blade lengths, each saw comes in a clear carry case with belt clip and a handle hole for attaching a carabiner, making it perfect for on-the-go pruning or outdoor tasks.





SILKY POCKET BOY FOLDING SAW - LARGE

PRODUCT CODE

346-17

Weight: 230g | Blade Length: 17cm | Saw Length: 21-37cm

The Silky PocketBoy 170mm Large Tooth Folding Saw is a compact, high-performance tool ideal for pruning, bushcraft, and outdoor use. Featuring Silky's Mirai-Me tooth technology, it offers fast, smooth cuts with minimal effort. Perfect for gardeners, arborists, and adventurers seeking precision in a pocket-sized saw.



SILKY SUPER ACCEL FOLDING SAW

PRODUCT CODE

119-21

Weight: 200g | Blade Length: 21cm | Saw Length: 24-44cm

The Silky Super Accel 210mm Extra-Large Tooth Folding Saw is a versatile, high-performance pruning saw ideal for both professionals and home gardeners. Its ultra-sharp teeth ensure fast, smooth cutting, while the folding design offers safe and compact storage. Perfect for general-purpose pruning tasks.



SILKY HOOK FOX FOR POLE SAWS

PRODUCT CODE

425-01

Hook

The Silky Hook Fox is a handy attachment for all Silky pole saws, designed to help move or manipulate branches and debris in trees. Ideal for pulling down deadwood or palm fronds, freeing jammed chainsaws, or lifting objects like service wires (without the blade attached), it's a versatile tool for arborists and gardeners alike.



SILKY HAYATE TELESCOPIC POLE SAW

PRODUCT CODE

371-42

Weight: 3170g | Blade Length: 50cm | Saw Length: 5.1m

377-42

Weight: 4500g | Blade Length: 42cm | Saw Length: 7.7m

The Silky Hayate is Silky's strongest and fastest-cutting telescopic pole saw, built for professionals but incredible for serious home gardeners. Ideal for tackling tough jobs like palm fronds and nut pods, it features a heavy-duty blade with sickle, robust scabbard, and high-reach extension pole. Available in 5.1 m and 7.7 m lengths.



SILKY FORESTER TELESCOPIC POLE SAW

PRODUCT CODE

273-45

Weight: 2270g | Blade Length: 38cm | Saw Length: 4.5m

The Silky Forester is a lightweight, telescopic pole saw with a high-visibility oval-shaped design, making it easy to spot outdoors. Featuring a 38 cm impulse-hardened blade for lasting sharpness, it's ideal for home gardeners and light enough for climbing use. Durable, easy to handle, and built to last a lifetime.





SILKY HAYAUCHI TELESCOPIC POLE SAW

PRODUCT CODE

178-39

Weight: 2650g | Blade Length: 39cm | Saw Length: 4.9m

179-39

Weight: 3280g | Blade Length: 39cm | Saw Length: 6.3m

This professional-grade telescopic pole saw is ideal for tree loppers, home gardeners, and general yard maintenance. Featuring oval-shaped aluminum poles for enhanced rigidity and control when cutting at height, it's equipped with a 390 mm precision Japanese steel blade with aggressive teeth for fast, clean cuts. Available in 4.9 m and 6.3 m lengths.



SILKY KATANABOY FOLDING SAW

PRODUCT CODE

403-50

Weight: 950g | Blade Length: 50cm | Saw Length: 65-113cm

710-65

Weight: 1310g | Blade Length: 65cm | Saw Length: 80-147cm

The Silky Katana Boy is a legendary, heavy-duty folding saw available in two sizes: a standard 50 cm blade and a massive 65 cm blade. Engineered for serious cutting power, it slices through large branches and logs with ease—perfect for camping, trail clearing, or storm clean-up. Despite its size, it folds compactly into its own carry bag to fit under a vehicle seat. With a sharpenable blade, easy maintenance, and built-in safety features, the Katana Boy is the ultimate tool for those who need serious sawing capability on the go.



SILKY YOKI AXE

PRODUCT CODE

570-27

Weight: 520g | Blade Length: 32cm | Length: 59cm

The Silky YOKI Chopper is a high-performance, versatile tool for clearing vegetation, cutting vines, and chopping small limbs. Combining bush axe functionality with Silky's renowned blade craftsmanship, it offers single- or two-handed use, a re-sharpenable steel blade, and a fitted sheath for safe storage—perfect for bushcraft and land clearing.



WOLF-GARTEN ANVIL LOPPING HEAD

PRODUCT CODE

RCM

Weight: 900g | Cut Capacity: 38mm | Length: 37cm

The Wolf-Garten Anvil Lopping Head is ideal for heavy-duty pruning at height. Its anvil-style cutting action and powerful pulley system make it perfect for cutting thicker branches with ease. Designed for use with Wolf-Garten ZMV3 or ZMV4 telescopic handles, it also fits ARS EXP extension poles using an optional adaptor.



WOLF-GARTEN PRO ANVIL LOPPING HEAD

PRODUCT CODE

RCVM

Weight: 1150g | Cut Capacity: 40mm | Length: 29cm

The Wolf-Garten Professional Anvil Lopping Head is a robust, heavy-duty tool designed for efficient high pruning. It features an adjustable cutting angle for precision and ease of use. Compatible with all Wolf-Garten handles, it can also be mounted onto the ARS EXP Extension Pole using an optional adaptor.





WOLF-GARTEN PRO BYPASS LOPPING HEAD

PRODUCT CODE

RRVM

Weight: 1050g | Cut Capacity: 36mm | Length: 29cm

The Wolf-Garten Professional Bypass Lopping Head is a heavy-duty tool designed for fast, precise pruning. Its bypass cutting action ensures clean cuts, and the adjustable head allows for optimal cutting angles. Compatible with all Wolf handles, it can also be mounted onto the ARS EXP Extension Pole using an optional adapter.



WOLF-GARTEN CURVED SAW HEAD

PRODUCT CODE

PCUT370

Weight: 400g | Cut Capacity: 38mm | Length: 60cm

This high-quality German-made pruning saw features a 370mm curved blade crafted from durable Swedish steel with push and pull cutting teeth. Designed for versatility, it can be used as a hand saw with its integrated grip or attached to Wolf-Garten ZMV3 or ZMV4 telescopic poles for high-reach tree pruning.



WOLF-GARTEN PRO CURVED SAW HEAD

PRODUCT CODE

PCUT370PRO

Weight: 460g | Cut Capacity: 40mm | Length: 61cm

Quality German-made pruning saw with a 370mm curved Swedish steel blade featuring push & pull teeth for efficient cutting. Designed for use with Wolf-Garten ZMV3 & ZMV4 telescopic poles for high-reach pruning, it also functions as a standalone hand saw with its integrated grip. Includes a branch hook for pulling and a bark cutter to reduce tearing.



BAHCO POLE PRUNING HEAD

PRODUCT CODE

P3437

This heavy-duty pruning head features a reverse hook cutting action for efficient, high-reach pruning and includes a fitting for an optional saw blade (not included). Supplied with pruner cord, it suits the AP5M pole and can also be adapted to fit ARS or Jameson poles.

WOLF-GARTEN ADJUSTABLE FRUIT PICKER

PRODUCT CODE

178-39

A convenient fruit picker attachment that mounts to any Wolf-Garten handle. Features plastic grips with a sharpened blade to cleanly detach fruit, which is then collected in the durable cloth bag above—perfect for harvesting from a variety of tree crops with ease.





BAHCO TELESCOPIC POLE

PRODUCT CODE

AP5M

Length: 2-5m

This lightweight triple-extension aluminum pole extends up to 5 metres and features a secure twist-lock mechanism, making it ideal for high-reach pruning and garden tasks.



BIG SHOT ROPE LAUNCHER

PRODUCT CODE

BSHOT

BSSP2P - Pole



The Big Shot Rope Launcher is a high-powered tool for launching throw bags and lines into tall tree canopies with speed and accuracy. Ideal for arborists and utility professionals, it mounts onto a Jameson or BSSP2P extension pole (sold separately) and enables efficient, controlled line placement at great heights.

BULLET THROWBAG

PRODUCT CODE

R0161601

Weight: 450g

This durable canvas throwbag is a must-have for any tree climber. Ideal for both mechanical launchers and hand throwing, it ensures accurate line placement in the canopy. Available in a range of sizes and weights to suit different climbing needs.



WOLF-GARTEN 3M EXTENSION POLES

PRODUCT CODE

ZMV3

Weight: 975g | Length: 1.7-3m

This durable, telescopic handle extends from 1.7 m to 3.0 m and is made from high-quality aluminum with a comfortable PVC grip. Compatible with all Wolf-Garten pruning and garden tool heads, it offers flexibility and reach for elevated tasks.



WOLF-GARTEN 4M EXTENSION POLES

PRODUCT CODE

ZMV4

Weight: 1230g | Length: 2.2-4m

This durable telescopic handle extends from 2.2 m to 4.0 m and is crafted from high-quality aluminum with a soft PVC grip. Compatible with all Wolf-Garten pruning and garden tool heads, it provides extended reach and comfort for elevated gardening tasks.



Follow Us on Social Media



Connect with us and keep up to date on all the latest



on Facebook @StrataGreen



on Instagram @stratagreen



on LinkedIn @StrataGreen



on TikTok @stratagreen





SECTION 11

MULTITOOLS AND
KNIVES

LEATHERMAN CHARGE PLUS TOOL

PRODUCT CODE

YL832516
Weight: 235G

The Leatherman Charge+ is a premium multi-tool built for adventure, featuring four outside-accessible blades, customizable bit drivers, and a strong 154CM steel knife. Packed with 19 tools—including needlenose pliers, replaceable wire cutters, saw, scissors, and multiple screwdrivers—it's ready for any task. Includes a comprehensive bit kit for added versatility, making it an ideal companion for outdoor enthusiasts, DIYers, and professionals alike



LEATHERMAN MUT TOOL

PRODUCT CODE

YL833093
Weight: 317g

The Leatherman MUT is a tactical multi-tool designed for military, law enforcement, and civilian shooters. It features threaded cleaning rod and brush attachments, sight adjustment tools, and easily replaceable components using a Torx #8. Built for field maintenance with minimal downtime, the MUT includes a MOLLE sheath and scope adjustment wrench, making it an essential, versatile tool for any firearm enthusiast or tactical professional.



LEATHERMAN SUPERTOOL 300

PRODUCT CODE

YL150L
Weight: 272g

The Leatherman Super Tool is built for heavy-duty tasks, featuring strong pliers, extra-long blades, and secure, easy-to-use locking mechanisms. It's the first Leatherman to include hollow-ground screwdrivers in standard professional sizes, making it ideal for tradespeople. With rounded, ergonomic handles, it offers a comfortable grip even during tough jobs, making it a reliable choice for serious work.



LEATHERMAN WINGMAN MULTITool

PRODUCT CODE

YL831436
Weight: 198g

The Leatherman Wingman is a compact, lightweight multi-tool ideal for everyday tasks at home, work, or on the go. Featuring a one-hand opening blade, spring-action pliers, and a versatile selection of tools, it offers great functionality in a pocket-sized stainless steel design. Made in the USA and backed by a 25-year warranty, the Wingman is a dependable and affordable go-to companion.



LEATHERMAN WAVE TOOL

PRODUCT CODE

YL205L
Weight: 241g

The Leatherman Wave+ is the brand's most popular full-size multi-tool, now upgraded with larger knives, stronger pliers, longer wire cutters, and all-locking tools for enhanced performance. Ideal for any job or adventure, the Wave+ is a versatile essential—and even more capable when paired with the optional Leatherman Bit Kit.





FELCO VICTORINOX BUDDING KNIFE

PRODUCT CODE

KN36230 (39020)

Blade Length: 6cm | Length: 10-16cm

Victorinox Budding Knife – Swiss-made quality featuring a 60mm stainless steel folding blade and bark lifter. Designed with a durable red nylon handle, it's ideal for budding and grafting tasks.



FELCO VICTORINOX GRAFTING KNIFE

PRODUCT CODE

KN36290 (39110)

Blade Length: 5cm | Length: 10-15cm

Victorinox Grafting Knife – Precision Swiss-made tool with a 55mm stainless steel blade and integrated bark-lifter. Features a sturdy red nylon handle, ideal for grafting and horticultural work.

BAHCO LOCKBLADE KNIFE

PRODUCT CODE

KAP1

Blade Length: 7cm | Length: 10-17cm

Bahco Lockblade Knife – A slim, pocket-friendly utility knife with a stainless steel locking blade for added safety and precision. Ideal for everyday tasks and outdoor use.



BAHCO PRUNING KNIFE

PRODUCT CODE

P20

Blade Length: 8cm | Length: 11-19cm

Folding Pruning Knife – Features a large, curved blade ideal for pruning tasks, with a comfortable rounded handle for ease of use. Compact 11cm length when closed.

EKOTEK BONING KNIFE

PRODUCT CODE

GTSHBK

Length: 15cm

The EkoTek Boning Knife is a tough, reliable tool ideal for bush regeneration, landscaping, and gardening. Featuring a sharp stainless steel blade and ergonomic high-visibility orange handle, it delivers clean, precise cuts even in demanding conditions. Built for durability and comfort, it's a must-have for outdoor professionals.



JAPANESE HORI HORI SOIL KNIFE

PRODUCT CODE

NISAKU650

Blade Length: 18.5cm | double edged blade

The Japanese Hori Hori Soil Knife is a rugged, all-purpose garden tool with a 185mm stainless steel blade featuring both straight and serrated edges. Ideal for digging, weeding, dividing plants, or cutting turf and roots, it's perfect for everything from bulb planting to irrigation work. Includes a durable leather pouch for safe storage.



GATOR MACHETE & SHEATH

PRODUCT CODE

GE41576

Blade Length: 38cm

The Gerber Gator Machete is a versatile tool designed for tackling thick undergrowth and track maintenance. Featuring a 38cm razor-sharp blade on one side and a high-performance saw on the other, it handles chopping and sawing with ease. Includes a durable sheath for safe storage and transport.



GERMAN GRAPE KNIFE

PRODUCT CODE

LOGKN

Blade Length: 5cm

The German Pattern Grape Knife is a trusted choice among grape harvesting contractors. It features a stainless steel serrated blade for efficient cutting and a high-visibility orange handle for easy spotting in the field. Ideal for professional vineyard work.



BARNEL SICKLE - SMALL

PRODUCT CODE

BLK720P

Blade Length: 11.5cm

This narrow sickle features a 115mm stainless steel non-serrated blade, perfect for harvesting tropical fruits, bananas, vegetables, flowers, and for bushcare work. Lightweight at just 70g with a compact 260mm overall length, it's ideal for precise and efficient cutting.



BARNEL SICKLE - LARGE

PRODUCT CODE

BLK727P

Blade Length: 11.5cm

This narrow sickle features a 115mm stainless steel serrated blade, ideal for harvesting tropical fruits, bananas, vegetables, and flowers, as well as for bushcare tasks. With an overall length of 340mm and weighing just 100g, it offers excellent reach and precision for a wide range of cutting applications.



BARNEL LONG HANDLED SICKLE

PRODUCT CODE

BLK737

Blade Length: 20.5cm

This long-handled sickle features a 205mm stainless steel non-serrated blade and a sturdy timber handle, making it ideal for harvesting fruits, vegetables, flowers, and for bushcare work. With an overall length of 610mm and weighing 290g, it offers extended reach and comfortable handling for efficient cutting.





SECTION 12

TOOL ACCESSORIES



CORONA SHARPENING TOOL

PRODUCT CODE

CAC8300

The 5" Super Carbide File is perfect for sharpening all types of blades with precision. Its slim design provides excellent access to secateurs and hard-to-reach areas, while the non-slip grip ensures safe and easy use. Compact enough to carry in your pocket or pouch, it's an essential tool for maintaining sharp, effective cutting edges.



BAHCO TUNGSTEN SHARPENER

PRODUCT CODE

SHARPEX

This professional tungsten carbide sharpener features a rubberized handle for a secure, comfortable grip and built-in finger stops for added safety. Ideal for quickly restoring a sharp edge to a variety of blades, it's a must-have for gardeners, landscapers, and tool users alike.



FELCO DOUBLE SIDED SHARPENING STONE

PRODUCT CODE

FE902

An innovative tool from Felco Switzerland, this professional-grade double-sided sharpening stone features a coarse grit for removing burrs and a fine grit for precision honing. Ideal for maintaining a razor-sharp edge on secateurs, loppers, and blades.



FELCO DIAMOND SHARPENING TOOL

PRODUCT CODE

FE903

This high-quality sharpening stone features a durable diamond coating for long-lasting performance. Its flat face is ideal for sharpening and honing pruning tools to a razor-sharp edge, while the hardened edges help strengthen and refine blade edges.



RYSET SHARPENING STONE

PRODUCT CODE

GT911

Keep your garden tools sharp and effective with the Ryset Fine Grit Sharpening Stone (GT911). Made from durable 220 grit silicon carbide, it's perfect for maintaining secateurs, knives, pruning shears, and more. The fine grit ensures smooth, precise sharpening to restore blade performance and extend tool life.



ARS SAW SHARPENING FILE

PRODUCT CODE

9F10

This purpose-built sharpening file is designed specifically for re-sharpening ARS pruning saw blades. Its slim diamond shape fits perfectly into the tooth gullets, while the fine edge allows for precise sharpening of each cutting point, ensuring optimal blade performance.





EZE-LAP CARBIDE SHARPENER

PRODUCT CODE

EE02

This compact pull-through sharpener is lightweight, durable, and easy to use—perfect for general household, workshop, and garden knives like box cutters and utility blades. It features a carbon sharpening insert that works quickly with light pressure and can be reversed for extended life.



EZELAP DIAMOND HONE

PRODUCT CODE

- EZLSF**
Super Fine
- EZLF**
Fine
- EZLM**
Medium
- EZLC**
Coarse
- EZLXC**
Extra Coarse

This popular, pocket-sized sharpener delivers a razor-sharp edge quickly and easily. Its slim design allows for effective sharpening of secateurs, loppers, hedge shears, and snips without disassembly. Available in five grit grades from Super Fine to Extra Coarse, it's a versatile tool for field or workshop use.

BAHCO LUBRICANT SPRAY- 50ML

PRODUCT CODE

LUB2015

Bahco Lubricant Spray (50ml) is a food-grade white oil specially formulated to reduce friction and ensure smoother cutting action for your tools. Packaged in a convenient plastic bottle with a precision spray nozzle, it delivers one drop per push—perfect for targeted application on bolts, joints, and moving parts.



ORGANIC

PELLENC HEDGE TRIMMER BAR OIL

PRODUCT CODE

P121633

Pellenc Organic Hedge Trimmer Bar Spray is a dual-purpose solution designed to lubricate and clean hedge trimmer bars. Made from organic ingredients, it ensures smooth operation and reduces wear while helping to remove sap and residue build-up for optimal cutting performance. Ideal for regular maintenance.

FELCO LUBRICANT SPRAY - 50ML

PRODUCT CODE

FE980

Felco 980 Universal Spray is specially formulated for cleaning and protecting all garden and workshop tools. It provides long-lasting corrosion protection and a water-repellent coating for all metal surfaces. Supplied in a convenient 50ml metal spray can for easy application.





CORONA LEATHER SCABBARD

PRODUCT CODE

CAC7220

This top-grain leather pouch is stitched and riveted for long-lasting durability. Designed with both a belt clip and loops, it offers versatile carrying options. The universal fit suits most brands of hand pruners, making it a practical addition to any gardener's toolkit.



FELCO SECATEUR POUCH + SHARPENER POCKET

PRODUCT CODE

FE910+

The FELCO 910+ is a premium leather holster designed to hold both your FELCO pruning shears and FELCO 903 sharpener. Durable and practical, it features both a belt loop and clip for versatile attachment, keeping your tools protected and within easy reach throughout the day.

FELCO SECATEUR POUCH

PRODUCT CODE

FE910

This high-quality leather Secateur Pouch is designed for professional use, featuring both a brass belt clip and belt slots for secure and versatile attachment. Durable and practical, it keeps your pruning tools protected and easily accessible.



RYSET PADDED SECATEUR POUCH

PRODUCT CODE

GT908

This durable Cordura nylon pouch features a universal design to fit both secateurs and folding saws. It includes a metal belt clip, belt loops, and a front pocket for storing a sharpener—ideal for keeping essential tools close at hand.

BAHCO BACK SUPPORT BELT

PRODUCT CODE

BA4750HDB1

This quality pruning support belt is designed to reduce back strain and fatigue during extended pruning tasks. Featuring a wide padded back support for added comfort and a durable leather belt for attaching lopper and pruner holsters, it's ideal for professional users seeking ergonomic relief on the job.



BAHCO QUICK RELEASE BELT

PRODUCT CODE

BA4750QLB1

The Bahco Quick Release Belt is a durable and comfortable accessory designed for use with secateur and lopper pouches. It features a quick-release buckle for easy on and off, making it ideal for professionals who need efficient access to their tools.



SECTION 13

LANDSCAPE TOOLS



RALLY GARDEN FORK

PRODUCT CODE

GTFKAM

The Rally Garden Fork is a heavy-duty, all-metal garden fork engineered for professional gardening, landscaping, and soil preparation work. Built with durable, hardened steel for strength and longevity, this fork excels at breaking up compacted soil, aerating ground, and digging out roots or weeds with ease.



CORONA 4 TINE MULCH FORK LONG HANDLE

PRODUCT CODE

CFK72004

Built for strength and precision, the 4 Tine Mulch/Bark Fork features a forged, tempered steel head and a lightweight yet durable handle. With fewer, widely spaced tines, it's perfect for lifting heavier, coarse materials like bark, branches, or chunky mulch. Ideal for landscapers, arborists, or anyone cleaning up after tree work.



CORONA DIGGING FORK

PRODUCT CODE

CFK42000

This heavy-duty fork features 4 forged, tempered tines designed for maximum strength and durability. The 10" tapered tines penetrate soil easily, while the 29" steel and Northern Ashwood D-handle offers excellent control and comfort—ideal for tight spaces and demanding tasks. Perfect for landscaping, digging, and material handling.



BIGHORN 6 TINE MANURE FORK

PRODUCT CODE

BH6TF

A versatile tool for gardening and landscaping, this manure fork features a durable 6-tine forged steel head (245mm wide x 345mm long) and a long 1370mm ash handle for strength and reach. Ideal for moving compost, mulch, manure, and other loose materials with ease.



CYCLONE MULCH FORK

PRODUCT CODE

C630866

The Cyclone Mulch Fork is a premium-quality tool designed for heavy-duty landscaping tasks. Featuring a wide 10-tine forged steel head (380mm x 400mm) for efficient mulch and debris handling, it's built for strength and durability. Fitted with a sturdy hardwood handle and D-grip, it's ideal for professional or large-scale garden clean-ups.

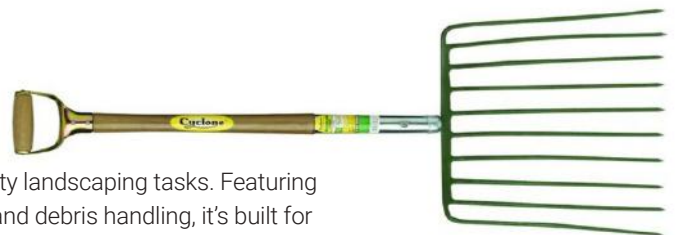

CORONA SHRUB RAKE

PRODUCT CODE

CRK62060

This rake features tempered spring steel tines for durability and long service life. Its bi-curved bow ensures even pressure across all tines, making it ideal for gentle debris removal without harming plant roots. The 8-inch narrow head fits easily between closely spaced plants, while the 54" lightweight metal handle with anti-slip vinyl sleeve provides comfortable control.





CORONA LEAF RAKE

PRODUCT CODE

CRK62061

This 25-tine rake features extra-wide, tempered spring steel tines for long-lasting durability and optimal performance. The 19-inch head has a bi-curved bow for even tine pressure, delivering efficient debris removal without disturbing plant feeder roots. A 54" lightweight metal handle with an anti-slip vinyl sleeve ensures comfortable and controlled use.

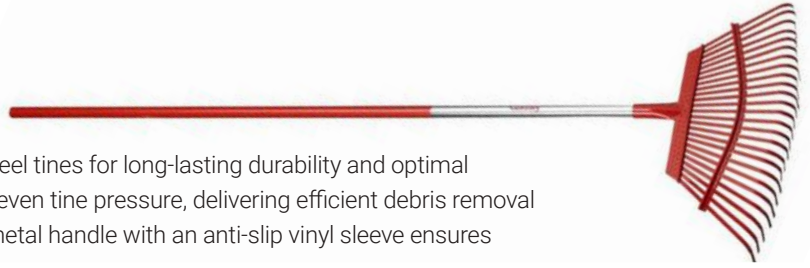

PREMIUM SUPA RAKE

PRODUCT CODE

PSR600

The Premium Supa Rake is a high-performance plastic rake built to handle tough yard work with ease. Made from a durable yet flexible blend of raw materials, it's designed to withstand rigorous use without breaking. Its long, closely spaced tines make quick work of leaves and fine debris, while the rear blade is perfect for shifting sand and gravel. Lightweight yet incredibly tough, this rake offers superior control and efficiency for all your garden clean-up tasks.

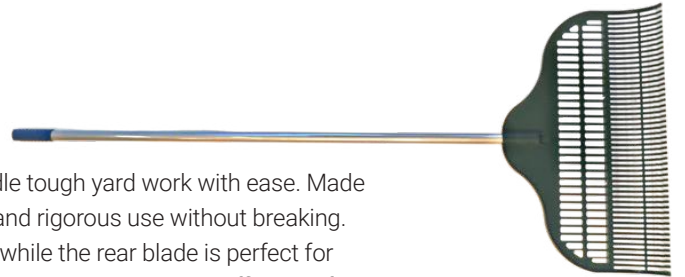

CORONA WIDE HEAD LEAF RAKE

PRODUCT CODE

CRK45030

This heavy-duty leaf rake features an extra-wide 750mm head for maximum leaf collection. Made from thick UV-stabilised vinyl, it offers excellent durability. The closely spaced, curved tines clear leaves efficiently in a single pass, making garden cleanup quick and easy.



CYCLONE LEAF RAKE

PRODUCT CODE

C636974

These high-quality Australian-made plastic leaf rakes feature a UV-stabilised 580mm wide poly head with a flat back scraper—perfect for shifting mulch or chips on hard surfaces like concrete or bitumen. Supplied with a strong 25mm x 1.35m aluminium handle for durability and ease of use.



CYCLONE LANDSCAPERS RAKE

PRODUCT CODE

C636516
14-tooth

C636554
16-tooth

This durable, well-crafted soil rake is ideal for levelling and spreading topsoil, sand, dressings, and fertilisers. Its one-piece steel head features a flat back edge for smoothing garden beds and lightly covering newly sown seed. Available in two sizes: 14-tooth (380mm wide head) and 16-tooth (430mm wide head), both fitted with a 150cm long hardwood handle for comfortable reach and control.



CYCLONE NAIL RAKE

PRODUCT CODE

20102110
14-tooth

C636240
16-tooth

This general-purpose rake is ideal for a range of gardening tasks, including raking soil, stones and leaves, as well as cultivating, scarifying, aerating and making seed furrows. Designed for both versatility and durability, it is available in two sizes: a 14-tooth version with a 370mm wide head and a 16-tooth version with a 430mm wide head. Each rake is fitted with a robust 150cm hardwood handle, offering excellent reach and comfort during extended use, making it a reliable tool for gardeners and landscapers alike.

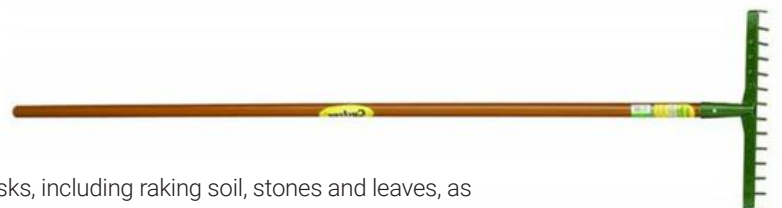



CORONA LANDSCAPE RAKE

PRODUCT CODE

CRK61061
600mm

CRK61062
900mm

Available in 900mm and 600mm widths, this Landscape Rake features a durable all-aluminium construction for strength and ease of use. The heavy-duty head includes angled, extra-thick tines and a wrap-around brace for added durability. A 60" lightweight aluminium handle with a non-slip vinyl sleeve ensures comfortable handling in all conditions.



CORONA TRENCH CLEANOUT SHOVEL - 150MM

PRODUCT CODE

CSS64106

The Corona 150mm Trench Clean-Out Shovel is a purpose-built tool for clearing wider trenches with ease and comfort. Featuring a 48" long Northern Ash handle angled at 35 degrees, it minimizes bending and helps reduce fatigue during repetitive use. The 150mm V-shaped open blade design enables effective digging and quick removal of material from trench bases, making it perfect for broader trenching tasks in landscaping, plumbing, or irrigation work.



CORONA TRENCH CLEANOUT SHOVEL - 100MM

PRODUCT CODE

CSS64104

The Corona 100mm Trench Clean-Out Shovel is specifically designed for precise trench maintenance and clean-up. Its 48" Northern Ash handle is angled at 35 degrees to reduce back strain and maximize efficiency when working in confined trench spaces. The 100mm-wide V-shaped blade, with no side walls, allows for clean and easy scooping of loose soil and debris, making it ideal for narrow trenches or tight excavation jobs.



CYCLONE SQUARE MOUTH SHOVEL - D HANDLE

PRODUCT CODE

C641763

The Cyclone D Handle Square Mouth Shovel is ideal for shifting and spreading materials in tight spaces. Its strong hardwood handle with ergonomic grip ensures control and comfort. Durable and versatile, it's backed by a 10-year warranty.

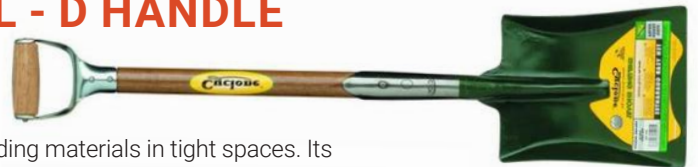

CYCLONE SQUARE MOUTH SHOVEL - LONG HANDLE

PRODUCT CODE

C642241

Perfect for larger tasks, the Cyclone Long Handle Square Mouth Shovel offers extended reach and reduced bending. Its sturdy hardwood handle and wide blade make it ideal for moving soil, sand, and gravel—complete with a 10-year warranty.



CYCLONE ROUND MOUTH SHOVEL - D HANDLE

PRODUCT CODE

C640803

Designed for control in confined spaces, the Cyclone Round Mouth Shovel with D Handle features a pointed blade for easy penetration in tough soils. Ideal for digging, shifting, and loading, with a strong hardwood handle and a 10-year warranty.





CYCLONE ROUND MOUTH SHOVEL- LONG HANDLE

PRODUCT CODE

C641282

Built for reach and digging power, the Cyclone Long Handle Round Mouth Shovel is perfect for heavy-duty tasks. Its pointed blade breaks through hard soil with ease, while the long hardwood handle reduces strain. Backed by a 10-year warranty.

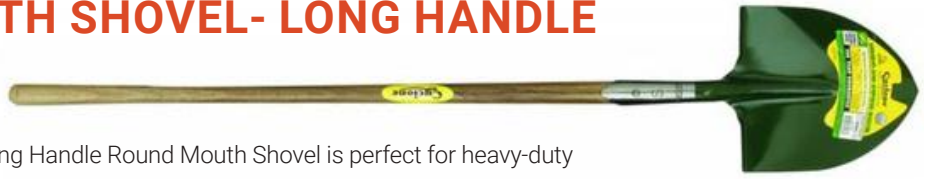

CYCLONE ROUND MOUTH POST HOLE SHOVEL

PRODUCT CODE

C640087

Built for strength and reliability, the Cyclone Round Mouth Post Hole Shovel is ideal for digging holes in loose soil or sand and trenching for pipe or drain installation. Featuring a solid forged head and a durable long hardwood handle, it's backed by a 10-year warranty for lasting performance.

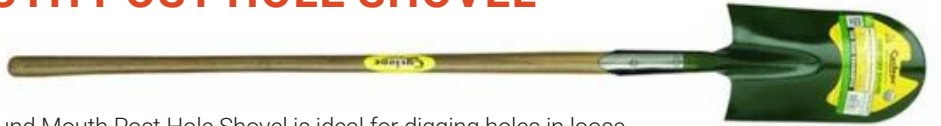

CYCLONE PLUMBERS SHOVEL

PRODUCT CODE

C639906

Designed for precision and durability, the Cyclone Plumbers Shovel features a narrow blade ideal for digging drains, laying pipes, and general shifting or spreading tasks. Fitted with a premium long hardwood handle, it offers comfort and control, backed by a 10-year warranty for peace of mind.



CYCLONE SQUARE MOUTH POST HOLE SHOVEL - FIBREGLASS

PRODUCT CODE

C640025

A tough, general-purpose shovel ideal for digging or clearing deep, narrow holes, fencing work, and shallow trenching. This model features a durable fibreglass long handle for added strength and user comfort, making it perfect for demanding tasks. Backed by a 10-year warranty.



CYCLONE SQUARE MOUTH POST HOLE SHOVEL- TIMBER

PRODUCT CODE

C640001

A high-quality, general-purpose shovel ideal for digging and clearing deep, narrow holes, fencing tasks, and shallow trenching. Fitted with a robust hardwood handle for durability and comfort during extended use. Supported by a 10-year warranty.



CYCLONE TRENCHING SHOVEL

PRODUCT CODE

C640216

A premium-quality shovel designed for precise narrow trenching, ideal for installing agricultural drainage, water and gas pipes, and cables. Features a solid long hardwood handle for strength and control. Backed by a 10-year warranty.



CYCLONE GARDEN SPADE - D HANDLE

PRODUCT CODE

C650970

A high-quality garden spade designed for digging and turning soil or clay in tight spaces. The short hardwood D handle offers excellent control and comfort, making it ideal for confined garden beds and detailed work. Backed by a 10-year warranty.





CYCLONE GARDEN SPADE- LONG HANDLE

PRODUCT CODE

C651045

This durable garden spade is perfect for digging and turning soil or clay with ease. The long hardwood handle provides extended reach and better leverage, reducing strain during use. Backed by a 10-year warranty.



GREENA ALLOY SHOVEL

PRODUCT CODE

SN504EH2

An ultra-lightweight shovel designed for easy handling when shifting light debris or top dressing. Features a durable aluminum head securely fitted to a hardwood handle, combining strength and comfort at an excellent value. Ideal for general garden or landscape use.

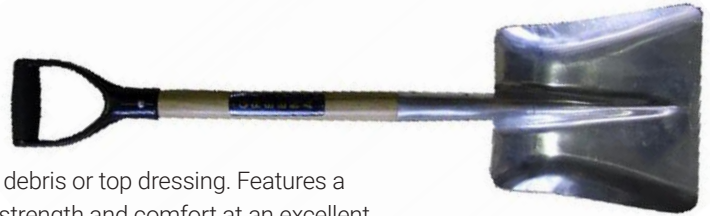

SPEAR & JACKSON ALLOY GRAIN SCOOP- D HANDLE

PRODUCT CODE

SJASG55

A durable and lightweight scoop ideal for shifting chips, mulch, and other loose materials. Features a high-grade 270mm x 400mm aluminum blade and a sturdy short hardwood handle with a comfortable poly D-grip. Perfect for landscaping and garden use.



SPEAR & JACKSON ALLOY GRAIN SCOOP- LONG HANDLE

PRODUCT CODE

SJAS56

This lightweight yet robust scoop is ideal for moving mulch, chips, and other loose materials. It features a high-grade 270mm x 400mm aluminum blade and a long, durable Australian hardwood handle for extended reach and comfortable use. Perfect for landscaping and agricultural tasks.

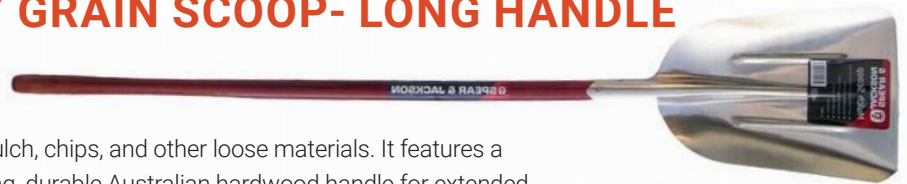

RALLY SHOVEL – ALL METAL 1200MM (BLACK)

PRODUCT CODE

GTSVAMBK1200

The Rally All-Metal Shovel with a 1200 mm handle is a durable, heavy-duty tool built for demanding garden, landscaping, and construction work. Made entirely from metal for strength and longevity, this shovel is designed for digging, planting, trenching, and general ground works where reliability and toughness matter.

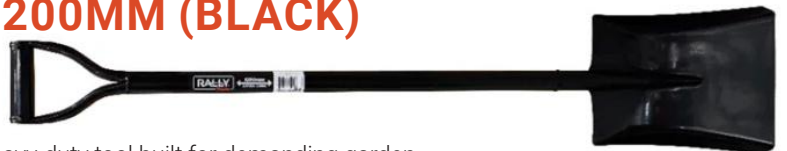

RALLY STEEL SQUARE MOUTH SHOVEL (WHITE)

PRODUCT CODE

GTSVELH

The Rally Steel Square Mouth Shovel with a long handle is a versatile, all-steel digging tool built for durability and precision. Designed for general garden, landscaping, and soil-work tasks, this shovel is ideal for edging, digging, trenching, transplanting, and moving soil or compost around garden beds and turf areas.

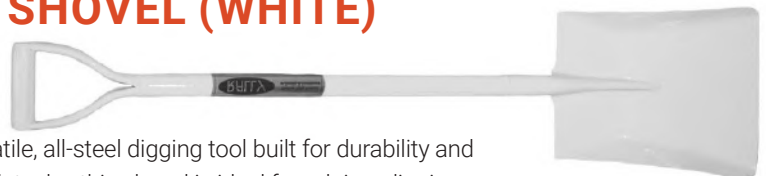

CORONA YARD BROOM - 600MM HEAD

PRODUCT CODE

CBM61002

This heavy-duty broom features a 600mm wide hardwood head with dual poly bristles—coarse for heavy debris and medium feathered for finer material—making it ideal for sweeping sidewalks, concrete slabs, and floors. It includes a scraper blade for tough dirt and steel braces to ensure stability and even bristle wear. Replaceable head for long-term use.

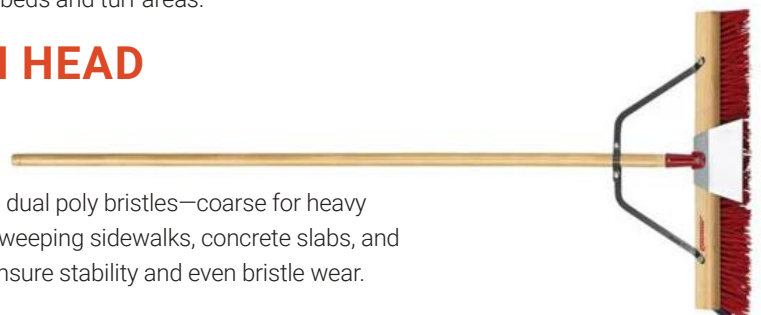



TOUGH STUFF OUTDOOR BROOM

PRODUCT CODE

- B35080**
400mm
- B35082**
600mm

Built for rugged outdoor use, the Tough Stuff Outdoor Broom is ideal for sweeping pavements, driveways, bitumen and other rough surfaces. It features a solid one-piece poly head with 75mm stiff bristles for heavy-duty sweeping, and a sturdy 25mm timber handle. Available in 400mm or 600mm head widths.



INDUSTRIAL MIX BROOM

PRODUCT CODE

- B35090**
400mm
- B35092**
600mm

Designed for tough sweeping tasks, the Industrial Mix Broom features a durable one-piece poly head with a combination of stiff and soft 75mm bristles for effective debris removal on pavements, bitumen, and other hard surfaces. Fitted with a sturdy 25mm timber handle, it's available in 400mm or 600mm widths to suit your needs.



COUNCIL ROAD BROOM

PRODUCT CODE

- B35037**

Built for heavy-duty sweeping, the Council Road Broom is ideal for clearing debris from roads, construction sites, and other tough surfaces. Its robust construction ensures long-lasting performance in demanding environments.



CORONA HD WEEDING HOE

PRODUCT CODE

- CSH63000**

The Corona HD Weeding Hoe features a durable, tempered steel blade that stays sharp and resists abrasion. Its sharpened, notched edge cuts powerfully on both push and pull strokes, making quick work of tough weeds like thistles and clumping grasses. Fitted with a 1500mm Northern Ash handle, it allows for upright operation to minimise back strain.



CORONA OSCILLATING HOE

PRODUCT CODE

- CSH60000**

Designed for efficiency and comfort, the Corona Oscillating Hoe features a self-sharpening 100mm concave blade that cuts weeds just below the soil surface on both push and pull strokes. Its heavy-duty construction ensures durability, while the 1500mm northern ash handle allows for upright use, reducing strain on the back during extended weeding sessions.



CORONA MAX 4 PRONG CULTIVATOR

PRODUCT CODE

- CCV60064**

The CORONA Max 4-Prong Cultivator features a durable, lightweight aluminum handle and four strong steel tines ideal for loosening soil, aerating, and removing weeds. Its ergonomic grip ensures comfortable use, making it the perfect tool for efficient garden maintenance.





CORONA DIAMOND HOE

PRODUCT CODE

CSH61000

The Corona Diamond Hoe features a sharpened, four-edge diamond-shaped blade for precision weeding on both push and pull strokes. Its pointed tips easily reach tight spots, while the durable carbon steel blade and strong welded socket deliver long-lasting performance. Fitted with a 1500mm northern ash handle for extended reach and reduced back strain.



CORONA 3 PRONG CULTIVATOR

PRODUCT CODE

CCV70003

This 3 Prong Cultivator features a forged, tempered steel head for exceptional durability and strength. Its 1500mm northern ash handle allows for upright use, helping to reduce back strain. The oval-section tines offer added strength and require less effort when cultivating soil. Ideal for breaking up and aerating garden beds.



CORONA DRAW HOE

PRODUCT CODE

CFH70000

The Corona Draw Hoe features a forged, tempered steel head for superior strength, sharpness, and durability. Its sharpened blade edge penetrates soil with ease, making it ideal for slicing through weeds and cultivating. The 1,500mm northern ash handle enables upright use, reducing back strain during extended gardening tasks.



CYCLONE CULTIVATOR

PRODUCT CODE

C629150

The Cyclone Cultivator features a solid three-prong head designed for effective soil aeration and loosening. Its sturdy tubular steel handle offers durability and strength, making it ideal for general garden cultivation and preparing soil for planting.



SPEAR & JACKSON TOP SOIL SPREADER

PRODUCT CODE

SJSS1

This well-crafted soil spreader is ideal for levelling and distributing topsoil, sand, fertilisers, and dressings. It's also perfect for preparing garden beds and covering newly sown seeds. The durable 710mm x 250mm tubular steel head is paired with a long hardwood handle for efficient, comfortable use.

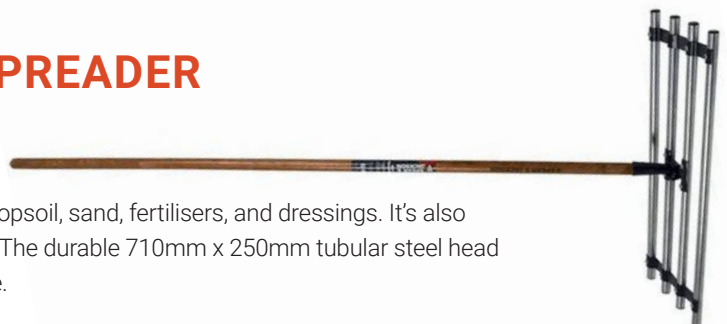

CYCLONE CUTTER-END MATTOCK

PRODUCT CODE

C634475
2kg Head

Ideal for grubbing out stumps, cutting roots, and general trenching work, the Cyclone Cutter End Mattock features a 2kg head with a sharpened blade for tough digging tasks. Fitted to a premium quality hardwood handle, it's built for durability and reliable performance.





CYCLONE RAKHO FIRE FIGHTING TOOL

PRODUCT CODE

C631849

The original and trusted fire fighting tool, the Cyclone Rakho is essential for country fire fighters, farmers, and contractors. Designed for tough conditions, it's fitted with a sturdy gum handle for strength and durability in the field.



GARDEN MASTER HAND TROWEL SOFT HANDLE

PRODUCT CODE

C638725

This durable hand trowel is made from heat-treated carbon steel with a sharp, long-lasting blade ideal for potting, planting, and dividing small plants. The ergonomic soft-grip handle with thumb rest offers comfort and control, while the twisted shaft helps prevent snagging. A hanging loop provides easy storage, and it's backed by a 10-year guarantee for lasting reliability.



GARDEN MASTER HAND BULB TROWEL SOFT HANDLE

PRODUCT CODE

C638749

The Garden Master Hand Bulb Trowel with Soft Grip is ideal for planting bulbs, transplanting, and re-potting small plants and seedlings. Its comfort grip handle fits naturally in the hand, providing ease of use across a range of garden tasks. Made with heat-treated carbon steel for durability and backed by a 10-year guarantee, this tool offers reliable performance and excellent value.



GARDEN MASTER HAND WEEDER

PRODUCT CODE

C638749

The Garden Master Hand Weeder with Soft Handle is a durable and comfortable tool designed for precise weed removal. Its ergonomic comfort-grip handle fits naturally in the hand, reducing fatigue during extended use. Ideal for tackling stubborn weeds in garden beds or tight spaces, this weeder delivers both efficiency and ease for everyday gardening.



GARDEN MASTER CULTIVATOR SOFT HANDLE

PRODUCT CODE

C638756

The Gardenmaster Hand Cultivator Soft Grip is ideal for aerating soil, breaking up clumps, and preparing garden beds or pots. Designed with a comfortable soft-touch handle and thumb grip, it offers excellent control and ease of use. Made from heat-treated carbon steel for strength and durability, this tool is built to last and includes a convenient hanging loop for easy storage—an essential addition to any garden tool set.



GARDEN MASTER HAND FORK SOFT HANDLE

PRODUCT CODE

C638763

Ideal for weeding and light cultivation around small, shallow-rooted plants, the Gardenmaster Hand Tool range combines comfort and durability for everyday garden use. This tool features a soft-touch handle with a thumb grip for superior control, heat-treated carbon steel blades for long-lasting performance, and a convenient hanging loop for easy storage. Backed by a 10-year guarantee, it offers exceptional value for money and is a reliable addition to any gardener's toolkit.





EZIREACHER LITTER TOOL

PRODUCT CODE

EZR50
50cm

EZR85
85cm

EZR100
100cm

EZR180
180cm



The Ezireacher Litter Tool combines precision and strength with lightweight alloy construction and rubber grip cups. It can delicately pick up small items like needles or firmly grasp heavier objects like bottles or bricks. Available in 50cm, 85cm, 100cm, and 180cm lengths, with replaceable rubber cups for long-term use. Ideal for litter collection in any environment.

RANGER MAX LITTER PICKER GRABBER

PRODUCT CODE

LP3036
89cm

Rugged and durable, the Ranger MAX heavy duty litter pickers are for the toughest jobs and a very popular option for local authorities, waste management professionals and community volunteers. The one-piece 35" litter picker grabber is the simplest of our designs, yet the technology provides you with a comfortable handle, a wide jaw opening for larger items, and reflective elements to keep you visible if operating in poor light.



STREETMASTER PRO LITTER PICKER

PRODUCT CODE

LP2020
83cm

LP2030
93cm

The Streetmaster Pro is a flexible, easy-grip litter picker designed for both indoor and outdoor use. Favoured by councils, facility managers, and community groups, it features a 90° rotating head for precise litter collection and a contoured comfort handle for extended use. Available in two lengths—82cm (32") and 93cm (37")—to suit various users and applications.



FISKARS X7 CAMPING AXE

PRODUCT CODE

F1121220X7

The Fiskars X7 Camping Axe is a compact and efficient tool ideal for outdoor use, whether stored in a rucksack, car, boat, or cabin. Perfect for cutting small trees, branches, and firewood, it's also suitable for light carpentry tasks. Its lightweight design and durable construction make it a versatile choice for campers, hikers, and outdoor enthusiasts.



FISKARS X17 SPLITTING AXE

PRODUCT CODE

F1122460X17

The Fiskars X17 Splitting Axe is a powerful and reliable tool designed for splitting medium-sized logs with ease. Featuring a drop-forged steel head for long-lasting sharpness and a virtually unbreakable fiberglass handle, it delivers superior performance and durability. The included plastic sheath ensures safe storage and transport, while the 720mm overall length offers excellent leverage. Made in Finland and backed by a lifetime warranty, the X17 is built to last.



TRASH BAG

PRODUCT CODE

TB00057
75 x 75 x 90 cm

The Trash Bag is a heavy-duty, high-capacity waste bag designed for tough clean-up jobs. Measuring 75 x 75 x 90cm, it provides ample space for collecting and transporting large volumes of debris, garden waste, or general rubbish. Constructed from durable material to withstand tears and punctures, this bag is ideal for use in landscaping, construction, and site maintenance.



BUILDERS BAGS

PRODUCT CODE

BB909090

This heavy-duty builders bag measures 90x90x90cm and is designed for carrying loads up to 1000kg. With a flat bottom and durable construction, it's ideal for transporting and storing aggregates, soil, sand, and other bulk materials on construction sites. A trusted standard in the building industry.



RYSET PLASTIC GARDEN HANDS

PRODUCT CODE

GD608

Ryset Plastic Garden Hands are a quick and efficient way to collect garden waste like leaves, grass clippings, and prunings. Lightweight and durable, these plastic scoops make tidying up your yard easier and safer. Designed for comfort and control, they come as a pair and are available in green.

SOLO PORTABLE MANUAL SPREADER

PRODUCT CODE

S0421

The Solo Portable Manual Spreader is ideal for applying fertilisers, seeds, and ice melters across uneven terrain. With a 9kg capacity and built-in agitator for even flow, it ensures consistent spreading. Adjustable fingertip controls manage direction and volume, while a padded cross-shoulder strap provides comfortable use. Lightweight at just 2.5kg.



ECHO HEAVY DUTY TURF BROADCAST SPREADER

PRODUCT CODE

RB-60

The ECHO RB-60 Heavy Duty Turf Broadcast Spreader is built for precision and durability in professional use. Featuring a 27kg hopper, corrosion-resistant powder-coated steel frame, and 10" pneumatic tyres, it handles tough jobs with ease. A pro-style T-handle provides fingertip chute control, while the foot-operated side deflector keeps material where it's needed. Its heavy-duty agitator prevents clumping for consistent spreading, and the rugged frame withstands extended use without failure.

EASYMIX WHEELBARROW POLY TRAY

PRODUCT CODE

MHWB1050

The Easymix Poly Tray Wheelbarrow features a high-capacity 99L poly tray constructed from durable 1.0mm material, ideal for handling heavy garden or construction loads. Its powder-coated 25 x 50mm steel handles provide strength and corrosion resistance, while contoured grips ensure comfort and control during use. Built for performance and reliability in tough conditions.



EASYMIX WHEELBARROW STEEL TRAY

PRODUCT CODE

MHWB1080

The Easymix Wide Tyre Wheelbarrow with Steel Tray is built for heavy-duty performance in demanding environments. Featuring a durable steel tray for tough loads and a wide pneumatic tyre for improved stability and manoeuvrability on uneven ground, this wheelbarrow is ideal for construction, landscaping, and general outdoor use. Its strong frame and balanced design make transporting heavy materials easier and more efficient.



WOLF-GARTEN POINTED HAND SCRAPER

PRODUCT CODE

KF-2K

The Wolf-Garten Pointed Hand Scraper is a compact, ergonomic tool ideal for removing moss and weeds from pavers, slabs, and tight spaces. Designed with a 3-zone comfort grip, it ensures precise control and reduced hand fatigue. Lightweight yet durable, it's perfect for detailed work in densely planted areas.



WOLF-GARTEN WEEDING KNIFE

PRODUCT CODE

KS2K

The Wolf-Garten Weeding Knife features a sharp V-shaped blade, perfect for removing deep-rooted weeds with ease. Ideal for spot weeding in all soil types, it makes tackling stubborn garden invaders quick and efficient. A must-have tool for precise and hassle-free weed removal.

WOLF-GARTEN 'AUTOMATIC' BULB PLANTER

PRODUCT CODE

FHN

The Wolf-Garten Bulb Planter is a clever tool designed for planting bulbs or bedding plants up to 6cm in diameter. It features an automatic soil release mechanism with a simple press of the handle, and a side gauge to ensure consistent planting depth every time.



WOLF-GARTEN TROWEL

PRODUCT CODE

LU2K

The Wolf-Garten Garden Trowel is a high-quality hand tool built for durability and ease of use. Made from heavy-gauge steel, it handles digging, planting, and potting tasks with strength and precision. The ergonomic, non-slip handle provides comfort during extended use, while the integrated hanger hole makes storage easy. Ideal for everyday gardening in beds, pots, and planters.

WOLF-GARTEN RETRACTABLE CORD TIDY FOR EXTENSION POLES

PRODUCT CODE

ZS-M

The Wolf-Garten Retractable Cord Tidy is a practical accessory for extension poles, designed to keep your pruning cord neatly stored when not in use. It also helps maintain consistent cord tension during operation, reducing tangles and improving efficiency while pruning at height.



WOLF-GARTEN POND NET

PRODUCT CODE

WKM

The Wolf-Garten Pond Net features a fine mesh ideal for skimming and collecting fine floating or suspended debris from ponds and water features. Perfect for maintaining clean, healthy water with minimal effort.



WOLF-GARTEN DRAW HOE

PRODUCT CODE

HU-M15

The Wolf-Garten Draw Hoe is perfect for precision weeding around plants and tight garden spaces. It features a 15 cm working width and a sharp, replaceable stainless steel blade for long-lasting performance and clean cuts. Ideal for maintaining neat and tidy garden beds.



WOLF-GARTEN SCUFFLE HOE

PRODUCT CODE

GSM14

The Wolf-Garten Scuffle Hoe is an efficient weeding tool that cuts through soil with a simple push or pull motion. Its 16cm wide blade features sharpened edges, making it perfect for thinning and slicing through weeds with ease. Ideal for quick, low-effort garden maintenance.

WOLF-GARTEN DUO HOE - STRAIGHT BLADE

PRODUCT CODE

ILM3

This high-quality Duo Hoe with a straight blade is ideal for lifting and breaking up sandy, light, or medium soils. The robust design allows for precise soil cultivation in garden beds, making it perfect for general weeding and loosening tasks around established plants.



WOLF-GARTEN DUO HOE - POINTED BLADE

PRODUCT CODE

IMM

Featuring a pointed blade, this sturdy Wolf-Garten Duo Hoe is excellent for penetrating compacted soil and targeting weeds with precision. Designed for durability and ease of use, it's ideal for cultivating and breaking up soil in tighter or more challenging spots.

WOLF-GARTEN CULTIVATOR

PRODUCT CODE

BEM

The Wolf-Garten Cultivator is a 11 cm wide tool designed to lift and loosen sandy, light, or medium soils, improving aeration and promoting healthy root growth. Ideal for preparing garden beds or maintaining soil structure.



WOLF-GARTEN PUSH-PULL WEEDER

PRODUCT CODE

RFM

The Wolf-Garten Push-Pull Weeder features a wavy, dual-edged blade that cuts through weeds with a simple back-and-forth motion below soil level. The blade self-sharpens during use, and side guards let you weed close to plants without damage.



WOLF-GARTEN LONGSPAN RAKE

PRODUCT CODE

UHM60

Designed for efficiency, this extra-wide 60cm rake collects large amounts of grass clippings quickly and easily. Its specially curved tines glide over lawns without digging in and are also ideal for levelling seed beds before sowing.



WOLF-GARTEN BOW RAKE

PRODUCT CODE

DOM40

This sturdy rake features a curved head that glides smoothly through soil or gravel, making it ideal for general garden use. The flat top is perfect for levelling seed beds, ensuring even soil distribution.



WOLF-GARTEN SOIL RAKE

PRODUCT CODE

DRM35

This high-quality universal garden rake features a solid steel head with curved teeth designed for effective soil penetration and collection. Ideal for breaking up, smoothing, and preparing garden beds with ease.



WOLF-GARTEN JOINT BRUSH

PRODUCT CODE

FB-M

The Wolf-Garten Joint Brush is perfect for clearing weeds, moss, and debris from cracks in driveways, patios, and footpaths. Its stiff, heavy-duty wire bristles make cleaning joints quick and effective without the strain. Replacement brush heads are available separately for extended use.

WOLF-GARTEN STREET BRUSH

PRODUCT CODE

B25M

A compact yet powerful cleaning tool, the Wolf-Garten 25cm Street Brush features tough, weatherproof synthetic bristles ideal for sweeping paths, driveways, and even snow. Built in Germany for durability, it's compatible with all WOLF-Garten Multi-Star handles and made to withstand year-round outdoor use.



WOLF-GARTEN LARGE BRUSH

PRODUCT CODE

DOM40

A versatile, high-quality broom ideal for general outdoor use. Features tough, 65mm long commercial-grade PVC bristles and a 40cm wide head for efficient sweeping of patios, paths, and driveways.

WOLF-GARTEN MULTI-CHANGE SCARIFYING ROLLER RAKE

PRODUCT CODE

URM3

The Wolf-Garten Multi-Change Scarifying Roller Rake is ideal for removing moss, thatch, and old clippings to promote a healthier lawn. Its curved steel tines lift debris while the built-in wheels make dethatching effortless. A great tool for improving lawn airflow, sunlight penetration, and nutrient absorption.





WOLF-GARTEN SCARIFYING RAKE

PRODUCT CODE

UGM3

Effortlessly remove moss and thatch from your lawn with the Wolf-Garten Scarifying Rake. Its 30cm wide head features spring steel blades with a pendulum action that makes clearing easier and more efficient. Compatible with all Wolf-Garten handles.



WOLF-GARTEN LAWN EDGE TRIMMER

PRODUCT CODE

RBM

Designed to neatly trim overhanging grass along garden beds and borders, this tool uses a scissor-like cutting action as you roll it forward. A clean, precise solution for tidy lawn edges without bending or straining.

WOLF-GARTEN TINE RAKE

PRODUCT CODE

UEM

Designed for efficient cleaning of gravel paths, driveways, and yards, this rake features 22 flat spring steel tines arranged in a fan and basket shape. Its wide capacity prevents material from spilling at the sides, making cleanup faster and easier.



WOLF-GARTEN ADJUSTABLE LAWN RAKE

PRODUCT CODE

UCM

This high-quality steel rake features adjustable tines that expand from 36cm to 58cm, making it perfect for both tight garden beds and wide areas like gravel driveways and yards. A versatile tool for efficient raking in any space.

WOLF-GARTEN MULTI-SWEEP PLASTIC RAKE

PRODUCT CODE

UIM

This lightweight, durable rake features 21 flexible plastic tines, ideal for clearing lawns, patios, paths, and hard ground without damaging surfaces. With a 42cm working width, it's compatible with all Wolf-Garten Multi-Change handles added versatility.



WOLF-GARTEN GARDEN ALUMINIUM D HANDLE 85CM

PRODUCT CODE

ZM-AD

This durable 85cm multi-star aluminium handle with D-grip is ideal for push-and-thrust tools like snow shovels, edge trimmers, thistle cutters, and weeders. Lightweight yet sturdy, it ensures comfortable handling and compatibility with all WOLF-Garten multi-star attachments.



WOLF-GARTEN HARDWOOD HANDLES

PRODUCT CODE

ZM140
140cm

ZM150
150cm

ZM170
170cm



These heavy-duty polished hardwood handles are built for durability and comfort. Available in 140cm, 150cm, and 170cm lengths, they are compatible with all WOLF-Garten tool heads, making them a reliable choice for any garden task.

WOLF-GARTEN ALUMINIUM HANDLES

PRODUCT CODE

ZMA140
140cm

ZMA150
150cm



These lightweight yet strong aluminium handles are designed for durability and ease of use. Available in 140cm and 150cm lengths, they are compatible with all WOLF-Garten tool heads, making them ideal for a wide range of garden applications.

WOLF-GARTEN EXTENSION POLES

PRODUCT CODE

ZMV3
1.7m - 3.0m

ZMV4
2.2m - 4.0m



The Wolf-Garten Telescopic Pole is a durable, high-quality aluminum handle designed for use with all Wolf pruning and garden tool heads. Its adjustable length—available in 3m (1.7m–3.0m) and 4m (2.2m–4.0m) options—makes it perfect for reaching high branches or working comfortably at ground level. A soft PVC sleeve provides a secure and comfortable grip.

WOLF-GARTEN HEAVY DUTY SMALL HANDLE

PRODUCT CODE

ZM04

The Wolf-Garten 40cm Small Handle is ideal for use with smaller Multi-Star rockery tools, such as trowels and forks. Its compact size and snap-lock connection provide precise control and easy tool changes, making it perfect for detailed garden work in confined spaces.



WOLF-GARTEN SMALL HANDLE

PRODUCT CODE

ZM02

The Wolf-Garten Small Handle is a compact 20cm handle designed specifically for use with Wolf-Garten trowels and forks. Its lightweight design and snap-lock connection make it perfect for detailed gardening tasks and confined spaces.



WOLF-GARTEN TOOL HOLDER

PRODUCT CODE

UMM

The Wolf-Garten Tool Holder is a practical storage solution, measuring 80cm in length and equipped with four individual holders. Perfect for organizing your tools and saving space in sheds, garages, or workshops.





TURFMASTER GOLF HOLE CUTTER

PRODUCT CODE

TM1

The Turfmaster Golf Hole Cutter is a globally trusted tool renowned for its precision, speed, and efficiency. Featuring dual 1.6mm case-hardened blades with razor-sharp, outward-facing bevels, it delivers clean cuts with minimal root disturbance. Hardened guide rings maintain consistent cutting accuracy, while a depth gauge ensures a perfect plug fit every time—eliminating the need for surface corrections and saving valuable time on the course.



BMS SOIL SAMPLER

PRODUCT CODE

SS25
25mm

SS50
50mm

The BMS Soil Sampler Probe (25mm) is a heavy-duty steel tool ideal for taking soil plugs on playing fields. It features a 300mm open barrel with a hardened steel cutter, allowing easy penetration into hard ground and clear inspection of soil structure before ejection. Built for durability and precision.

BMS TURF DOCTOR

PRODUCT CODE

TD150
150mm/sq

TD230
230mm/sq

The BMS Turf Doctor is a precision tool for repairing and patching turf. It cuts inverted pyramid-shaped sods, ensuring each plug fits snugly into place without gaps. This design maintains a firm, level surface, making it ideal for high-traffic turf areas or sports fields.



BMS HAND AERATOR

PRODUCT CODE

AER3T

The BMS Hand Aerator is a durable, professional-grade tool ideal for relieving compaction in small areas or improving water penetration in moisture-repellent soils. Designed for precision, it ejects soil cores from the top of the tine bar, making it easy to use and highly effective for treating dry patches.

BMS ROUND PLUGGER

PRODUCT CODE

RP50E
50mm

RP100
100mm

RP150
150mm

The BMS Round Plugger is a robust turf tool featuring a zinc-plated steel body and a replaceable, heat-treated steel blade for clean, precise cuts. Adjustable for depths between 50–100mm, the 100mm and 150mm models include a foot-operated, spring-loaded ejector for easy plug removal. Ideal for turf maintenance and repairs.



BMS ALUMINIUM DUMMY RAKE

PRODUCT CODE

ALDUM05
500mm

ALDUM10
1,000mm

The BMS Aluminium Dummy Rake is a durable, lightweight tool ideal for levelling sand or top dressing. Available in 500mm and 1000mm widths, it features a folded aluminum head that's reversible for flat or angled use. The 1.8m timber handle includes cross stays for added strength, making this rake a long-lasting alternative to wooden-head models.



RALLY CONCRETE RAKE – ALUMINIUM (BLACK)

PRODUCT CODE

GTCRPULL

The Rally Concrete Rake is a professional-grade concrete finishing tool built for efficiency, strength and ease of use – ideal for contractors, builders, and tradies working on concrete slabs, paths, driveways, sidewalks or other flatwork projects.



BMS LANDSCAPER LEVEL LAWN

PRODUCT CODE

LL800
800mm

LL1000
1,000mm

The BMS Landscaper Levellawn is built for heavier-duty spreading tasks, making it ideal for tough landscaping jobs. Available in 800mm and 1000mm widths, the head is constructed from rigid 16mm square tube with strong end bracing for added durability. Each model comes fitted with a 1.8m timber handle for extended reach and control.



RALLY SOIL SPREADER

PRODUCT CODE

GTSS

The Rally Soil Spreader is an essential landscaping tool when you need to distribute topsoil, compost, sand, mulches, or soil conditioners evenly across beds, garden plots or turf areas. Built for reliability and consistent results, this spreader makes light work of tasks that would otherwise take substantial time and effort by hand.

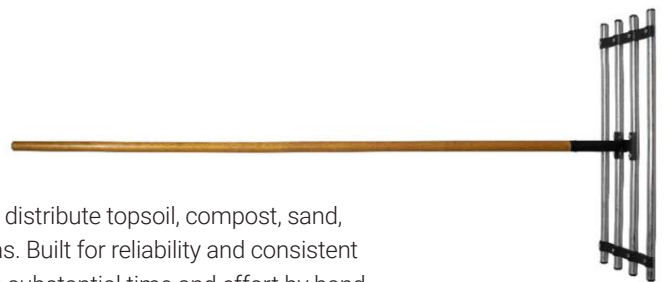

STEEL DRAG MAT

PRODUCT CODE

DMAT

The StrataGreen Steel Drag Mat is a durable and effective tool commonly used by golf courses and local councils. Ideal for working top-dressing into uneven surfaces like greens and tees, it follows contours without flattening the area. Lightweight and versatile, it can be easily towed behind mowers, quads, or carts for efficient large-area coverage.





BMS GREENKEEPER LEVEL LAWN

PRODUCT CODE

LL760
760mm**LL920**
920mm

The BMS Greenkeeper Levellawn is a trusted, industry-standard tool for turf professionals worldwide. Available in 760mm and 920mm widths, its lightweight yet robust design is ideal for evenly spreading screened topsoil. The three open-top inner bars trap small stones, while the angled front and rear bars help clear excess material. Both models come fitted with a 1.8m timber handle for comfortable, efficient use.



COMPASS LAWN LEVELLER

PRODUCT CODE

LL2W
450mm x 1210mm

The Compass Lawn Leveller is a high-quality tool designed for efficient top dressing and levelling of lawns. It features a 450mm wide screed section and 1210mm length for effective coverage, with large 450mm pneumatic wheels for smooth manoeuvrability. The adjustable handle height enhances user comfort, and the heavy-duty frame separates into two pieces for easy, compact storage.



Formline Colour Swatch

Formline landscape edging is available in a carefully curated range of powdercoat colours designed to complement Australia's most widely used architectural palettes. These tones have been selected to harmonise seamlessly with common roofing, fencing and façade finishes, making it easy to achieve a cohesive look across outdoor spaces. Durable, UV-stable and finished to a high standard, each colour maintains its appearance over time while integrating naturally into both contemporary and traditional landscape designs.

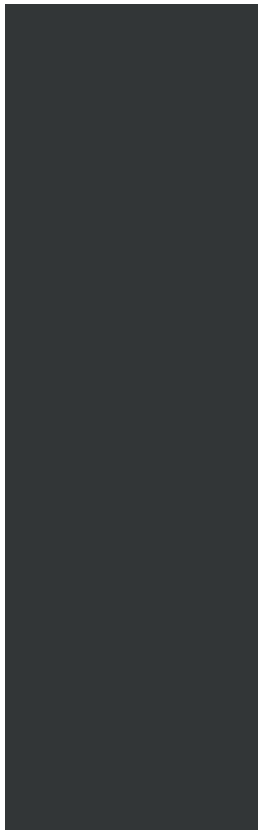

Powder-coated
Charcoal



Powder-coated
Black

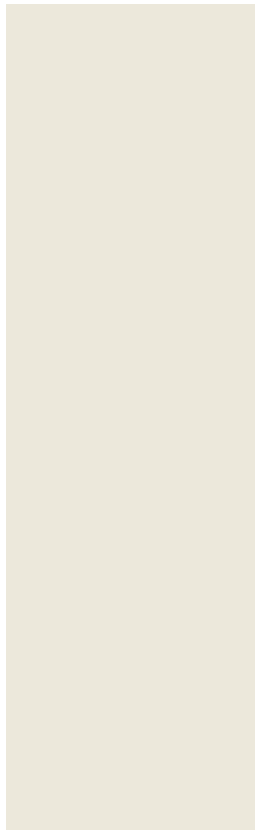

Powder-coated
White



Weathering Steel

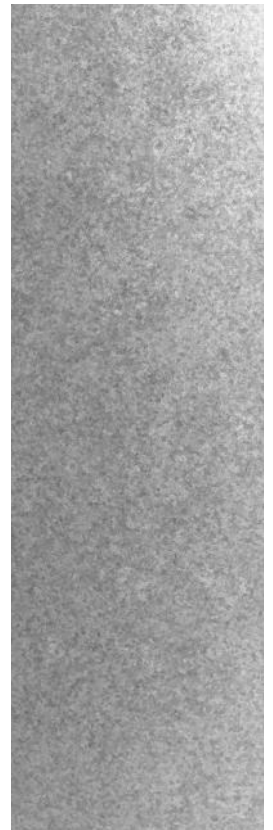

Galvanised Steel

Formline sizes

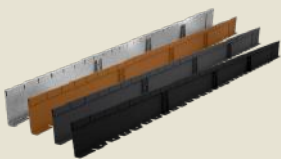

Landscape Edging
150mm

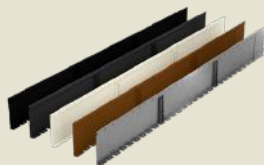

Raised Garden Bed
250mm

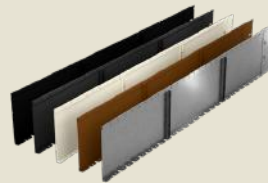

Raised Garden Bed
400mm

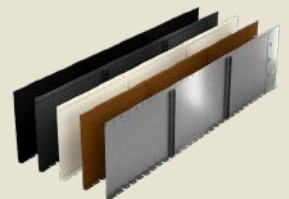

Raised Garden Bed
550mm

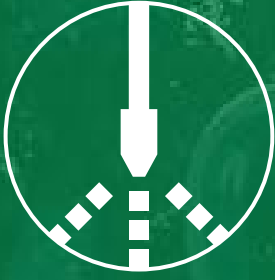

SECTION 14

SPRAYING
EQUIPMENT



HILLS TRIGGER SPRAYERS

PRODUCT CODE

H100722
 500ml

H100723
 1L

The Hills Trigger Sprayers are ideal for small spraying jobs around the home or garden. Available in both 500ml and 1L sizes, these sprayers are made from durable, chemical-resistant plastic for long-lasting use. Each features an adjustable nozzle for precise spray control—from fine mist to direct stream—and a long, ergonomic trigger for comfortable handling. Whether you're applying pesticides, fertilisers, or cleaning solutions, these versatile sprayers make the task quick and easy.



INTER KNAPSACK SPRAYER

PRODUCT CODE

INTER12
 12L

INTER16
 16L

The Inter 12L and 16L Knapsack Sprayers are built for professional-grade performance in horticulture, landscaping, and general spraying applications. Both models feature a durable fibreglass lance, reinforced tank ribs for strength, and an eccentric pressure chamber with an integrated suction tube for efficient operation. Designed for comfort and reliability, they are ideal for applying herbicides, pesticides, and liquid fertilisers over small to large areas. Backed by a 3-year guarantee, these sprayers combine high build quality with dependable performance.

INTER PRESSURE SPRAYERS

PRODUCT CODE

INTER1
 1L

INTER7
 5L

INTER9
 6L

The Inter Pressure Sprayer is a high-quality and reliable tool ideal for garden and professional use. Available in 1.5L, 5L, and 7L capacities, each model features a Viton chamber valve for enhanced chemical resistance and durability. Designed for easy maintenance, all parts are easily accessible, making cleaning and servicing simple. Backed by a 3-year guarantee, this sprayer delivers dependable performance for a wide range of spraying tasks.



INTER INDUSTRIAL SPRAYERS

PRODUCT CODE

IK1
 1L

IK9
 6L

IK12
 12L

The Inter Industrial Sprayers are built for demanding applications, made from high-resistance materials and fitted with Viton seals throughout. Ideal for applying aggressive chemicals such as acids, disinfectants, and degreasers, they are available in 1.5L and 7L pressure sprayers, and a 12L knapsack sprayer. Each unit is backed by a 3-year guarantee, ensuring durability and reliability in tough working conditions.

INTER ACCESSORIES

PRODUCT CODE	ITEM DESCRIPTION	PRODUCT CODE	ITEM DESCRIPTION
YA00A	Pressure Regulator	YA00R	2 Nozzle Spray Boom
YA00B	Rectangular Hood	YA00H	Flexible 2 Nozzle Boom
YA00C	Conical Hood	YA00J	Telescopic Lance
YA00E	4 Nozzle Spray Boom	YA00F	Fan Nozzle





SWISSMEX PRESSURE SPRAYER

PRODUCT CODE

SW319
5L

SW320
7L

The Swissmex pump-up sprayers are constructed from heavy duty components for lasting performance in the field or commercial applications. A wide filling neck ensures spillages are a thing of the past. The rugged lance comes complete with a fully adjustable nozzle, strong lever-type shut-off and pressure filter. The lance clips securely to the pump handle for convenient storage and transport. Built-in pressure relief valve.



SWISSMEX KNAPSACK SPRAYER

PRODUCT CODE

SW503
15L

Built for tough, commercial use, this 15L sprayer features a powerful dual piston/diaphragm pump for over 6 bar pressure, plus Viton seals for chemical resistance. Includes a wide-fill port, pressure filtration, durable lance, and adjustable nozzle for versatile spraying.

SWISSMEX ACCESSORIES

PRODUCT CODE	ITEM DESCRIPTION
Pakman	Knapsack Protective Vest
SW219140C	Mini Spray Boom 2 Nozzle
SW219282C	Spraying Boom 4 Nozzle
SW219099	Spray Guard Large 40cm

PRODUCT CODE	ITEM DESCRIPTION
SW219117	Spray Guard Small 22cm
SW219236C	Telescopic Lance to 94cm
SW219143C	Extension Tube 150cm
SW219089C	Brass Adjustable Nozzle



SOLO PRESSURE SPRAYERS

PRODUCT CODE

S0456
5L

SU257
7L

The Solo pressure Sprayer is a high-quality German-made unit designed for professional use. Built for durability, it features a sturdy tank, comfortable shoulder strap, and a safety valve for reliable operation. Ideal for heavy-duty spraying tasks in landscaping, horticulture, or general maintenance.





SOLO BATTERY BACKPACK SPRAYER

PRODUCT CODE

S0417LI-S
10L - 2 Speed

The Solo 10L Battery Backpack Sprayer – 2 Speed offers all the features of the popular 417Li in a more compact tank size. With up to 4 hours of continuous spray time, this lightweight and ergonomically designed unit is perfect for larger home gardens and landscape maintenance. Includes lithium battery and charger. Ideal for weed control, shrubs, decorative plants, and plantations.



SOLO KNAPSACK SPRAYERS

PRODUCT CODE

S0473D
10L

S0475
15L

The Solo 10L and 15L Knapsack Sprayers are premium German-made backpack sprayers designed for durability and user comfort. Featuring UV-resistant plastic tanks, these sprayers are built to withstand harsh conditions. The ergonomically shaped containers ensure a comfortable fit, while the robust metal pump lever can be stored vertically for convenience. Ideal for professional use in landscaping, horticulture, and general spraying tasks.

SOLO 18V BATTERY POWER BACKPACK SPRAYER

PRODUCT CODE

S0442LI
16L

The Solo 18V Battery Power Backpack Sprayer (16L) is a high-performance sprayer built for professional use. Delivering up to 5 hours of continuous operation at 1 bar pressure and recharging in just 1 hour, it's ideal for demanding applications. Features include a battery charge indicator, electronic pressure regulator for consistent output, and a 16L tank for extended coverage. Perfect for large gardens, agriculture, pest control, and public landscaping. Includes lithium battery and charger.



SOLO BATTERY BACKPACK SPRAYER

PRODUCT CODE

S0414LI
10L

The Solo 10L Battery Backpack Sprayer (Model 414Li) is a lightweight, easy-to-use sprayer designed for home and garden use. It eliminates the need for manual pumping, offering effortless spraying with its rechargeable lithium battery. Ideal for weed control, decorative plants, and larger garden areas, it comes complete with a battery and charger for convenient, ready-to-use performance.

SOLO ACCESSORIES

Product Code	Item Description	Product Code	Item Description	Product Code	Item Description
S04900514	Mini Spray Boom 2 Nozzle	S04900449	Extension Tube 120cm	S04900206	Adjustable Brass Nozzle
S04900626	Small Round Drift Guard	S04900445	Telescopic Spray Tube	S04900599	Solo Professional Harness
S04900513	Extension Tube 50cm	S04900430	Oval Drift Guard		



SOLO BATTERY POWER BACKPACK SPRAYER

PRODUCT CODE

SO441LI
16L

The Solo 441Li 16L Battery Backpack Sprayer is a robust, lightweight solution ideal for contract gardeners, acreage owners, and hobby farmers. This semi-professional sprayer handles liquid fertilisers, herbicides, fungicides, and insecticides with ease. Complete with a lithium battery and charger, it's perfect for efficient weed control and plant protection across gardens, farms, and landscapes.



SOLO BATTERY BACKPACK SPRAYER

PRODUCT CODE

SO417LI
18L - 2 Speed

The Solo 18L Battery Backpack Sprayer – 2 Speed offers quiet, efficient spraying with minimal effort. Powered by a 12V lithium battery, it delivers consistent performance and extended operation time, ideal for demanding professional and large-scale garden use. Includes charger and battery, making it ready for immediate action.

SOLO BATTERY POWERED SPRAYER

PRODUCT CODE

EAZY206
6L

The Solo EAZY 206 6L Battery Powered Sprayer is a compact, versatile unit designed for ease of use. With up to 170 minutes of continuous spray time and a consistent 2.5 bar pressure, it eliminates manual pumping. Featuring a lithium-ion battery, adjustable nozzle, spiral hose, and multiple carrying options, it's perfect for gardens and small-scale applications.



SOLO HOSE END SPRAYER

PRODUCT CODE

SU405HE

The Solo Hose End Sprayer is a versatile and user-friendly tool designed to simplify your spraying tasks. With Triple Thread Compatibility, it fits most popular chemical concentrate bottles, making it easy to use without the need to transfer liquids. Ideal for applying fertilizers, herbicides, or insecticides directly from the bottle—just attach to your garden hose and spray.

SOLO BATTERY POWER HAND SPRAYER

PRODUCT CODE

SO260LI
1L

The Solo 1L Battery Power Hand Sprayer (260Li) is a compact, efficient solution for garden, household, and cleaning tasks. With up to 60 minutes of continuous spray time, it eliminates the need for manual pumping. Ideal for plant care, weed control, fertilising, and general cleaning. Includes lithium battery and charger.





WEEDMASTA KNAPSACK TROLLEY 16L

PRODUCT CODE

SVB0016L0024T
16L

The WeedMasta 16L Knapsack/Trolley Sprayer offers efficient, hassle-free spraying with a powerful 12V rechargeable battery delivering over two hours of continuous use. Its ergonomically designed tank ensures comfort, while a flow rate control, volt meter, and kink-resistant hose provide precision and convenience. With a reliable 70psi pump, multiple nozzles, double filtration, and an included charger, this sprayer is built for performance and ease. Suitable for knapsack or trolley use.



TRANS TANK WEEDCONTROL SPOT SPRAYER

PRODUCT CODE

SVS0055L0077
55L

SVS0055L0077
95L

SVS0055L0077
150L



The Trans Tank Weedcontrol 12V ATV Spot Sprayer is available in 55L, 95L, and 150L sizes, making it ideal for a range of spraying tasks on farms, rural properties, or gardens. Featuring a powerful 8.3L/min 12V pump, it delivers consistent pressure for effective weed control. Built tough for the outdoors, this unit easily mounts to an ATV, UTV, or utility vehicle, offering a practical and efficient solution for spot spraying applications.

REELSTRIKE PRO SPOT SPRAYERS

PRODUCT CODE

PVQ0200LK0076H3
200L

The 200L ReelStrike 12V Sprayer is a powerful, self-contained spot spraying unit ideal for larger properties and professional use. It features a 7.5L/min 100psi pump, pressure regulator with gauge, and a robust steel frame with pump cover for durability. The hose reel holds 30 metres of 10mm spray hose, paired with the AHG110 Powerjet spray gun for precision application. Designed for efficiency and ease of use in demanding spraying tasks.



SPOTPRO SPOT SPRAYER

PRODUCT CODE

PUF0200L0120H
200L



The SpotPro 200L Spot Sprayer is built for performance and reliability, featuring a genuine Honda GX35 4-stroke engine with a 3-year warranty. Its Australian-made UV-stabilised poly tank includes a fully draining sump for efficient cleaning and maximum chemical usage. With a 30-metre hose and reel, hot dip galvanised steel frame, and secure mounting system, this sprayer is ready to tackle a wide range of spot spraying tasks with ease.

ALL CLEAR TANK WASH AND EQUIPMENT CLEANER

PRODUCT CODE

ACTW05
5L

TankWash Tank and Equipment Cleaner is a powerful detergent blend specially formulated for effectively cleaning pesticide sprayers and related equipment.





ONE DECK COMPACT - 300L



TOP CROP - 300L



TOP CROP - 500L



SUPER REEL - 400L



SUPER REEL - 600L



GLIDEPATH - 1000L



TRAILPRO - 200L



TRAILPRO - 200L WITH REEL



TRAILPRO DELUXE - 200L



TRAILPRO DELUXE - 400L



AQUAPATH - 2000L



AQUAPATH - 5000L



FIREPATROL14 - 1000L



FIREPATROL15 - 3000L

**TALK TO US
ABOUT YOUR
OPTIONS TODAY!**

PROTECT WHAT YOU PLANT MESH TREE GUARDS BUILT FOR AUSTRALIAN CONDITIONS

Safeguard young trees from animal damage and harsh environments with StrataGreen's Mesh Tree Guard Range. Whether you're dealing with kangaroos, cattle or sheep, our guards provide long-lasting, field-tested protection for your regeneration and landscaping projects.



Mesh Kangaroo Tree Guard – 800mm High

Ideal for protecting smaller tubestock or plantings in lower-pressure areas. The 800mm guard offers a lightweight, cost-effective solution that still delivers sturdy protection while allowing airflow and sunlight for healthy growth.

Specifications:

- Guard dimensions: 800mm height x 350mm diameter
- Aperture Size: 100mm x 50mm
- Wire Gauge: 1.5mm
- Finish: Galvanised
- Pack Size: 20 guards
- Stakes sold separately



Mesh Kangaroo Tree Guard – 1200mm High

A popular choice for revegetation projects, this tall guard offers reliable protection against kangaroos and browsing wildlife. Made from tough, galvanised mesh, it's easy to set up, reusable, and designed for long-term field performance.

Specifications:

- Guard dimensions: 1200mm height x 460mm diameter
- Can also be configured: 1500mm height x 350mm diameter
- Aperture Size: 100mm x 50mm
- Wire Gauge: 2.0mm
- Finish: Galvanised
- Pack Size: 20 guards
- Stakes sold separately



Thorny Devil Spiked Tree Guard – 1200mm High

Specifically designed to deter larger animals like cattle and sheep, the Thorny Devil features an integrated spiked mesh design for enhanced protection. This rugged guard is perfect for use in paddocks, grazing zones, or remote revegetation sites.

Specifications:

- Guard Dimensions: 1200mm height x 460mm diameter
- Can also be configured: 1500mm height x 350mm diameter
- Aperture Size: 100mm x 50mm
- Wire Gauge: 2.0mm
- Finish: Galvanised
- Features: Integrated spiked mesh design
- Pack Size: 20 guards
- Stakes sold separately



SECTION 15

**POWER EQUIPMENT
ACCESSORIES**



BAR & CHAIN OIL

PRODUCT CODE

LUB6008
1L

LUB6009
4L

Protect your chainsaw with premium Bar & Chain Oil, available in both 1L and 4L sizes. This high-performance oil provides superior lubrication to reduce friction and wear, while its tacky formula prevents sling-off—even at high speeds. Ideal for professionals and home users alike, it delivers consistent performance in all seasons, helping extend the life of your bar and chain while improving cutting efficiency.



2-STROKE OIL

PRODUCT CODE

LUB6005S
1L

LUB6006
4L

Available in 1L and 4L sizes, this high-performance semi-synthetic 2-stroke engine oil is formulated for both oil injection and pre-mix systems. Dyed light blue for easy identification, it provides excellent lubrication and engine protection, ensuring smooth, reliable performance in all 2-stroke applications.

4-STROKE OIL

PRODUCT CODE

LUB6120
1L

LUB6009
4L

This quality 4-stroke engine oil suits many Honda, Kawasaki, and Kohler engine models. Designed to deliver reliable performance and engine protection, it's ideal for a wide range of outdoor power equipment. Always consult your engine manufacturer's manual to confirm the correct oil specification for your engine.



SPEED FEED 450 LARGE PREMIUM QUALITY TRIMMER HEAD

PRODUCT CODE

BRN6923

The Speed Feed 450 is a high-quality, large-capacity trimmer head designed for professional use. It features a fast, hassle-free line loading system—just align, feed, and twist to reload in seconds without disassembly. Built tough for commercial applications, it fits most straight shaft trimmers and holds a generous amount of line for extended cutting. Ideal for landscapers and contractors who demand durability and efficiency on the job.



CHAMP 5 BRUSHCUTTER HEAD

PRODUCT CODE

AV1325

Grade aluminium

The CHAMP 5 Brushcutter Head is a high-performance, fixed-line head designed for straight shaft brushcutters that accept a blade. Built from durable marine-grade aluminium and engineered for tough Australian conditions, it features a robust, no-moving-parts design. Typically loaded with three lines (six cutters), it offers extended cutting time—often up to two hours—before needing a line change. Compatible with all straight shaft models rotating anti-clockwise, it mounts directly onto a 25mm riser and includes a C spanner for easy setup and maintenance.





SUPERCUT HEAVY TRIMMER LINE

PRODUCT CODE

AB1340
350mm

SuperCut Heavy Trimmer Line is a high-performance, professional-grade cutting line designed specifically for use with the CHAMP 5 brushcutter head. Made from a durable nylon and polypropylene blend, it features a square profile for faster cutting and longer wear. Each pack includes 90 pre-cut 350mm lengths for convenient, efficient loading.



TRAILBLAZER TRIMMER LINE

Trailblazer Trimmer Line is a premium, professional-grade line made from high-quality co-polymers for maximum durability and impact resistance. Its round profile reduces splitting and fraying for cleaner cuts and longer run time—ideal for heavy-duty trimming.

Product Code	Specifications				Product Code	Specifications			
TZ241	2.4mm	450g	Donut	87m	TZ245	2.4mm	2.25kg	Spool	435m
TZ271	2.7mm	450g	Donut	70m	TZ275	2.7mm	2.25kg	Spool	350m
TZ331	3.3mm	450g	Donut	46m	TZ335	3.3mm	2.25kg	Spool	230m

DESERT VORTEX TRIMMER LINE

SuperCut Heavy Trimmer Line is a durable, professional-grade cutting line made for the CHAMP 5 head. Its nylon-polypropylene blend and square profile deliver fast cutting and long wear. Includes 90 pre-cut 350mm lengths for easy loading.



Product Code	Specifications				Product Code	Specifications			
BRT6951	2.4mm	500g	Donut	70m	BRT6498	2.4mm	1.5kg	Spool	208m
BRT6953	2.7mm	500g	Donut	56m	BRT6957	2.7mm	1.5kg	Spool	167m
BRT6955	3.3mm	500g	Donut	36m	BRT6500	3.3mm	2.2kg	Spool	187m



DIAMOND EDGE TRIMMER-LINE

Diamond Edge Trimmer Line offers enhanced cutting power with 20–30% more rigidity and increased mass for greater impact. Its copolymer construction ensures durability, while the square profile delivers clean, efficient cuts.

Product Code	Specifications				Product Code	Specifications			
BRT5156	2.4mm	450g	Donut	76m	BRT5277	2.4mm	2.25kg	Spool	381m
BRT5157	2.7mm	450g	Donut	62m	BRT5278	2.7mm	2.25kg	Spool	315m
BRT5158	3.3mm	450g	Donut	41m	BRT5279	3.3mm	2.25kg	Spool	205m



Chemical Spraying Course

Two-day course for: Basic weed control - Lawn & Garden
- Landscaping - Bushland / Mine Site rehabilitation

UNITS OF COMPETENCY:

AHCCHM307: Prepare and apply chemicals to control pest, weeds and diseases

AHCCHM304: Transport and store chemicals

AHCPMG301: Control Weeds

COMPETENCIES COVERED INCLUDE:

- The Law- APVMA, Health Act, Pesticide regulations, licensing, compliance
- Knowing your pesticide- toxicity, LD50, schedules
- Labels- Role of APVMA, label requirements, reading labels
- Toxicity, LD50, schedules
- Understanding labels- reading and heeding, mixing ratios
- Chemical absorption, PPE- types and usage
- Basic equipment types- compression, backpack (electric spray and manual units)
- Introduction to spray tips- spot spray, fan jet, air venturi
- Using equipment- preparing equipment, mixing chemicals, cleaning of equipment
- SDS – role of/interpreting
- Transport of chemicals- current Health Department requirements
- Spills, disposal of empty containers
- Weed biology
- Non selective/selective herbicides
- Weed ID
- Application techniques
- Treatment records

1

INCLUDED IN THIS REGISTRATION:

- Morning Tea
- Lunch
- Fruit and Drinks
- Warehouse Tour
- 30% discount on the Application Spray Logbook.
- Additional Pest and Disease Presentation

2

BOOK HERE



3

ATTEND THE TWO-DAY COURSE:

5 Barrel Way, Canning Vale
Western Australia





SECTION 16

SAFETY AND
MARKING



FIRE EXTINGUISHERS

PRODUCT CODE

FE001
 1kg

FE4501
 4.5kg

FE9001
 9kg

Firex Dry Powder (ABE) Fire Extinguishers are reliable, Australian-certified safety devices available in 1kg, 4.5kg, and 9kg sizes. Designed to meet AS/NZS 1841 standards, they are suitable for use on Class A, B, and E fires. Each extinguisher comes with a wall mounting bracket for easy installation and quick access in emergencies.



SPILLFIXER ABSORBENT

PRODUCT CODE

SF20
 20kg

Spill Fix Absorbent 30L is a lightweight, non-dusty solution ideal for heavy-duty workshops and industrial environments. It quickly absorbs oils, fuels, and chemicals without leaching pollutants, making it an efficient and cost-effective choice for spill management and cleanup.

UNIVERSAL ABSORBENT PADS

PRODUCT CODE

MAX-GPPL4545
 200mm x 310mm x 420mm

General Purpose Absorbent Pads (200 pack) are made from a blend of polypropylene and other materials to quickly absorb oils, fuels, chemicals, solvents, and more. Ideal for workshops and spill kits, these pads offer fast, reliable cleanup for a wide range of liquids.



ABSORBENT ROLL 200GSM

PRODUCT CODE

MAXGPRL5045
 450mm x 50m

The MAXSorb General Purpose Absorbent Roll (200gsm, 450mm x 50m) delivers fast and efficient spill control in a continuous roll format. Ideal for managing leaks and small spills, it offers the same high absorbency as MAXSorb pads and fits perfectly onto standard roll dispensers for easy use.

FLAMMABLE STORAGE CABINET

Firex Dry Powder (ABE) Fire Extinguishers are reliable, Australian-certified safety devices available in 1kg, 4.5kg, and 9kg sizes. Designed to meet AS/NZS 1841 standards, they are suitable for use on Class A, B, and E fires. Each extinguisher comes with a wall mounting bracket for easy installation and quick access in emergencies.

Product Code	Description	Weight	Dimensions
AU25748	100L - 2 Shelves, 2 Doors	86.1kg	800 x 920 x 565
AU25302	160L - 3 Shelves, 2 Doors	104.8kg	1230 x 1100 x 465
AU25452	250L - 3 Shelves, 2 Doors	142kg	1760 x 1100 x 465
AU25602	350L - 3 Shelves, 2 Doors	177.8kg	1760 x 870 x 870





SPILL CONTROL KIT

PRODUCT CODE

MAX-120GP
120L

MAX-240GP
240L

Spill Control Kits (120L and 240L) are your ultimate defense against hazardous spills. Packed with a full range of absorbents, booms, and pads, these kits handle chemicals, oils, fuels, acids, and alkalis with ease. Perfect for larger workshops, chemical storage areas, or industrial sites.



BUDDI SPILL CONTROL KIT

PRODUCT CODE

BUDDI-U

The Buddi Spill Control Kit is a compact, easy-to-carry solution for managing small spills quickly and effectively. Ideal for utes, trucks, laboratories, or small chemical store sheds, it's designed to handle oil, fuel, chemical, and acid spills. A versatile and reliable choice for on-the-go spill response.



PORTABLE FIRST AID KIT

PRODUCT CODE

FAP3814

320mm x 145mm x 180mm

This Portable First Aid Kit is an ideal grab-and-go solution for workplaces or sites with 5–24 people in low to medium risk environments. Housed in a durable 320 x 145 x 180mm plastic carry case, it provides essential medical supplies for quick response in emergencies.



METAL CABINET FIRST AID KIT

PRODUCT CODE

FAM4817

290mm x 440mm x 115mm

The Metal Cabinet First Aid Kit is built for medium to high-risk environments and is suitable for up to 99 people. Housed in a durable, lockable, powder-coated metal cabinet (290 x 440 x 115mm), it offers secure and accessible storage and can be wall-mounted or used as a portable unit for flexible deployment.



PERSONAL FIRST AID KIT

PRODUCT CODE

FAPP

195mm x 155mm x 45mm

The Personal First Aid Kit is compact and convenient, ideal for treating minor injuries while on the move, on site, or in small office environments. Housed in a durable ABS case, it fits easily into a glovebox, travel bag, or toolkit. Dimensions: 195mm x 155mm x 45mm.



SNAKE AND SPIDER BITE KIT

PRODUCT CODE

LSSB

15 cm x 2 cm

The Snake & Spider Bite Kit includes trusted AEROBAND compression bandages to ensure effective first response care. It features one 15cm bandage (ideal for full leg coverage), two 5cm compression bandages for the bite site, and a large instant ice pack. Compact, reliable, and essential for outdoor safety.





4 DRUM BUNDED PALLET

PRODUCT CODE

SDBP4L

The 4 Drum Bundled Pallet is a heavy-duty containment solution for safely storing chemicals and hazardous goods. Designed with a removable grate for easy cleaning, it allows secure placement of up to four drums. Pallet truck and forklift entry points ensure efficient handling, and the nestable design simplifies storage and transport.



2 DRUM BUNDED PALLET

PRODUCT CODE

SDBP2L

The 2 Drum Bundled Pallet is a durable and compliant solution for storing two drum bunds, specifically designed for flammable liquids. Built with robust construction, it offers reliable containment and is engineered to withstand tough Australian conditions, making it ideal for industrial and outdoor use.

DRIP TRAY

PRODUCT CODE

AMDTS

Small - 520mm x 360mm x 80mm - 15L Capacity

AMDTM

Medium - 610mm x 410mm x 100mm - 30L Capacity

AMDTL

Large - 840mm x 660mm x 115mm - 50L Capacity



Our ultra-tough, Australian-made Drip Trays are ideal for workshops and around machinery, perfect as drip catchers or for tool and parts storage. Made from 3mm chemical-resistant polymer, they offer outstanding impact and UV resistance, meeting strict AS/NZ standards for long-term outdoor use. Available in three sizes—15L, 30L, and 50L—these trays are built to perform in Australia's harshest conditions.

Product Code	Colour
SSMY	Yellow
SSMW	White
SSMR	Red
SSMG	Green
SSMFP	Pink
SSMFO	Orange
SSMBL	Black
SSMB	Blue

SIGNET SPOT MARKING SPRAY

Signet Spot Marking Spray is a high-quality, Australian-made marker spray ideal for use on concrete, timber, grass, soil, and bitumen. Designed for handheld inverted application, it's perfect for survey and construction marking. The formula is lead-free and available in a wide range of vibrant colours, including Fluoro Green, Fluoro Blue, Red, Fluoro Yellow, Fluoro Orange, Fluoro Pink, Black, and White.



Product Code	Colour
SSLY	Yellow
SSLR	Red
SSLG	Green
SSLBL	Black
SSLB	Blue
SSLW	White

SIGNET LINE MARKER PAINT

Signet Line Marking Paint is a versatile, lead-free spray designed for both handheld inverted use and use in line marking machines. Suitable for marking on concrete, timber, grass, soil, and bitumen, it delivers bright, durable lines for a range of applications. Available in 500g cans and colours including Yellow, Red, Blue, Black, White and Green.





LINE MARKING APPLICATOR

PRODUCT CODE

OASL

The Line Marking Applicator is a durable and easy-to-use tool designed for efficient application of Line Marking and Survey Marking Paint. Its ergonomic design and simple trigger mechanism reduce operator fatigue and ensure precise, consistent results—perfect for large marking jobs.



SIGNET FIELD MARKING PAINT

PRODUCT CODE

- S16601**
15L - Black
- S16602**
15L - Red
- S16603**
15L - Blue
- S16604**
15L - Green
- S16605**
15L - Yellow
- S16609**
15L - White

Signet Field Marking Paint – 15L is a water-based, grass-safe paint specially formulated for marking all types of sporting fields and pitches. It delivers bright, long-lasting lines with excellent coverage, even over dark grass, reducing the number of coats needed. Mixes at 4:1 (water to paint), producing up to 75L of usable product. Compatible with all line marking machines and dries in just 15 minutes under sunlight.

SPRINKLER MARKING FLAGS

PRODUCT CODE

HUNTERFLAGS
120mm x 100mm

Sprinkler Marking Flags provide a quick and easy way to mark dripper lines, sprayed areas, or other site locations. Each flag measures 120 x 100mm and comes with a 500mm steel wire stake for secure placement. Ideal for landscaping, irrigation, and ground marking tasks. Sold in packs of 100qty



PLIFIX LOCATION MARKERS

PRODUCT CODE

- PF-BLUE**
Blue - 25pk
- PF-RED**
Red - 25pk
- PF-WHITE**
White - 25pk
- PF-YELLOW**
Yellow - 25pk

PLiFiX Location Markers are durable synthetic grass implants designed to mark underground assets, site hazards, or key locations on sports fields. Ideal for marking tanks, cables, sprinklers, or for guiding line marking, PLiFiX is easy to install, highly visible, and can be left in place or repositioned as needed. Available in red, white, blue, and yellow. Pack of 25.

TRAFFIC CONES - PLAIN

PRODUCT CODE

BTC760 450mm
BTC761 700mm

The Buddi Spill Control Kit is a compact, easy-to-carry solution for managing small spills quickly and effectively. Ideal for utes, trucks, laboratories, or small chemical store sheds, it's designed to handle oil, fuel, chemical, and acid spills. A versatile and reliable choice for on-the-go spill response.





TRAFFIC CONES - REFLECTIVE

PRODUCT CODE

BTC760R
450mm

BTC761R
700mm

Reflective Traffic Cones are Australian Standards approved and available in 450mm and 700mm sizes. Designed for roadwork and civil applications, each cone features a reflective band for enhanced visibility in low light and night conditions, ensuring added safety for workers and the public.



TRAFFIC BOLLARD

PRODUCT CODE

BTB758
1155mm

The 6kg Traffic Bollard is Australian Standard approved and ideal for roadwork and civil applications. Standing 1155mm high, it features a sturdy 6kg base for stability and a T-top design, making it easy to attach barrier tape or chain for enhanced site safety and visibility.

ORANGE FLAG BUNTING

PRODUCT CODE

SFBF30
30m coils

The Orange Flag Bunting is an economical and effective way to cordon off hazardous or restricted areas. Featuring bright orange flags for high visibility, it's ideal for construction sites, events, or safety zones. Supplied in 30m coils for easy setup and storage.



GREEN FLAG BUNTING

PRODUCT CODE

BUNTG
30m coils

Green Flag Bunting is an effective solution for clearly marking and defining site zones. Each 30m length includes approximately 45 durable flags, offering high visibility and quick installation. Easily attach to posts or poles to enhance safety and organization on your worksite.

FLAGGING TAPE

PRODUCT CODE

HA17024
White

HA17025
Red

HA17021
Orange

HA17023
Blue

HA17020
Yellow

HA17022
Fluro Pink

HA17026
Green

Flagging Tape is a bright, durable marker widely used by contractors and horticulturists for site works, tree planting, and plant production. Available in a range of high-visibility colours—white, red, orange, blue, yellow, pink, or green—each roll measures 25mm wide by 75m long for easy application and clear identification.



'DANGER' BARRICADE TAPE

PRODUCT CODE

BTD713
100mm

'DANGER' Barricade Tape is designed to clearly mark hazardous areas with bold red and white stripes and the word 'DANGER' printed prominently. The 75mm wide, 100-metre long roll is ideal for creating visible barriers around unsafe zones on work sites or public areas.



'CAUTION' BARRICADE TAPE

PRODUCT CODE

HA16100

76mm x 100mm

'CAUTION' Barricade Tape is a durable, heavy-duty tape ideal for marking off construction zones, maintenance areas, or any site requiring restricted access. Featuring bold 50mm lettering on a high-visibility yellow background, each roll measures 75mm wide by 100m long for extensive coverage.

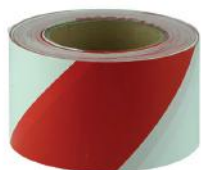

RED & WHITE BARRICADE TAPE

PRODUCT CODE

BTR713

75mm X 50m

Red and White Barricade Tape is a high-visibility, non-adhesive tape ideal for marking off restricted or hazardous areas. Made from heavy-duty polyethylene, each roll measures 75mm wide by 50m long, offering a durable and weather-resistant solution for temporary barriers.

BARRIER MESH

PRODUCT CODE

SPSMO

1m x 50mm

Orange Barrier Mesh is a cost-effective solution for cordoning off unsafe or restricted areas. Highly visible in bright orange, it's easy to install and ideal for construction sites or public events. Supplied in a 1 metre high x 50 metre long roll.



MESHMATE HI-VIS SAFETY MESH SUPPORT POST

PRODUCT CODE

MMP1400R

The MeshMate® Hi-Vis Safety Mesh Support Post is a smarter, safer way to set up exclusion zones. Designed to slip over 900–1,650mm star pickets, it eliminates sharp edges while holding mesh securely with built-in buttons. A flag rope cap and Class 1 hi-vis reflective striping ensure maximum visibility and convenience on site. Rugged, easy to use, and built for safety.

MINIMATE STAR PICKET CAP

PRODUCT CODE

MMSPC

MiniMate Star Picket Cap is a tough, all-in-one solution for securing mesh and flag rope while covering pickets for added safety. Three times longer than standard caps, it offers extra coverage and durability. Made in Australia from UV-stabilised PVC, it's built to last and outperforms typical plastic alternatives.



BASEMATE PLASTIC SUPPORT BASE FOR STAR PICKETS

PRODUCT CODE

BMPB

BaseMate™ Plastic Support Base is a non-ground penetrating solution for holding star pickets securely—no digging or permits needed. Made in Australia from recycled plastic, it's ideal for use on hard surfaces and pairs easily with rubber weights. Quick, eco-friendly, and cost-effective for temporary fencing or markers.



STAR PICKET CAPS

PRODUCT CODE

SDCAP

20qty per pack

Star Picket Caps are designed to fit securely over steel and plastic star pickets, reducing the risk of injury from exposed picket tops. Their bright, triangular shape enhances on-site safety and visibility. Sold in packs of 20.



EXTRA HEAVY DUTY RING TOP POST

PRODUCT CODE

G64245

7mm x 850mm

A heavy-duty 7mm thick, 850mm tall steel pig tail post designed for use with barrier chains, tapes or ropes. Ideal for creating temporary or semi-permanent exclusion zones. Durable and versatile for outdoor use. Sold in packs of 10

DONAGHYS 3 STRAND NYLON ROPE

PRODUCT CODE

180539

10mm | 100m Reel Size | 1550kg Strength

180547

12mm | 100m Reel Size | 2200kg Strength

180554

14mm | 100m Reel Size | 3100kg Strength

This premium-grade 3-strand rope is strong, durable, and easy to handle—ideal for use with pigtail or ring top posts as a temporary pedestrian barrier. Its moderate elasticity helps absorb movement and tension, while the twisted construction ensures long-lasting performance in outdoor conditions. Suitable for crowd control, restricted zones, or event perimeters.



SYMBOLIC WORKMAN SIGN

PRODUCT CODE

SG516

900mm x 600mm

STD5

900mm x 600mm

Durable 900 x 600mm Class 1A Reflective sign with a swing stand for quick setup and transport. Built to meet Australian Standards, this heavy-duty sign ensures maximum visibility and safety on roadwork and construction sites.

“Mowing in progress,”
“Spraying in progress,” ...
and more

SWING STAND AND SPRAYING SIGNS

PRODUCT CODE

STD660

600mm x 600mm

STD661

600mm x 600mm

Ensure clear communication and safety on site with our Swing Stand & Spraying in Progress Sign options. Both feature a durable swing stand and a 600x600 caution sign with a Glyphosate magnet for added visibility and clarity. Option one (STD660) includes a standard “Spraying in Progress” sign, while Option two (STD661) displays “Spraying in Progress ACWAWSID” for sites requiring specific compliance signage. Ideal for councils, contractors, and vegetation management crews.

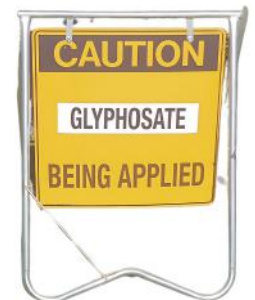



MEASURING TAPES

PRODUCT CODE

- TBC8025I**
8m
- TBC1025I**
10m

The Sterling Professional Tape Measure is available in 8m and 10m lengths and built for durability and comfort. It features a tough 25mm wide metric blade with a triple-riveted hook end for long-lasting use. The Duragrip moulded rubber case provides a secure, comfortable grip, making it ideal for professional and trade applications.



OPEN REEL TAPE

PRODUCT CODE

- OF5013**
50mm
- OF10013**
100mm



The Open Reel Fibreglass Tape is a durable and lightweight measuring tool, ideal for tough outdoor conditions. It features a strong 100m fibreglass tape encased in flexible, easy-clean plastic, housed in a sturdy open reel plastic case. Built to withstand extreme weather, it's perfect for landscaping, construction, and surveying work.

ANALOG DISTANCE MEASURING WHEEL

PRODUCT CODE

- MW12**
9999m/feet

The Sterling Measuring Wheel is a lightweight, user-friendly tool for accurately measuring distances up to 9999 metres or feet. It features an analogue display, ergonomic pistol grip handle, sturdy steel kickstand, and a foldable design for convenient storage and transport—ideal for surveying, landscaping, and construction tasks.



TALK TO US ABOUT YOUR SITE SAFETY REQUIREMENTS!

CHEMICAL STORAGE

SIGNAGE

BARRIERS

SPILL CONTROL

PROVEN PERFORMANCE. MEASURABLE RESULTS.

Independent Testing Shows Significant Performance Differences

Independent laboratory testing shows TerraCottem delivers significantly higher water holding capacity than alternative soil conditioning products.

Total Water Holding Capacity (mL water held per 100g)	Water Holding Capacity
TerraCottem Universal	6116 mL / 100g
Alternative Product	3199 mL / 100g
Alternative Product	656 mL / 100g

Testing conducted by SESL Australia (ISO 9001 Certified).

Performance Is Not Just a Marketing Claim

- 💧 Tested under Australian Standard methodology
- 💧 Independently verified results
- 💧 ISO 9001 certified laboratory
- 💧 Full reports available on request



TERRACOTTEM
Leading soil conditioning technology





SECTION 17

PROTECTIVE EQUIPMENT



CLOGGER ZERO G2 CHAINSAW PANTS

The Clogger Zero Gen2 Chainsaw Pants represent a significant advancement in protective gear for arborists and forestry professionals. Building upon the success of the original Zero line, the Gen2 pants offer improved durability, comfort, and safety tailored for demanding work environments.

Constructed with a high-tenacity nylon ripstop outer, the fabric is now 1.5 times stronger than the previous version, ensuring greater resistance to wear and tear. For optimal cooling, Nilit® Breeze fibers are woven into the fabric to wick heat away from the body, while dual side vents and an open leg design provide excellent airflow for hot conditions.

The Gen2 pants feature Clogger's exclusive Arrestex HP chainsaw protection—six layers of advanced cut-resistant fabric extending from waist to ankle, with extra coverage on the left leg. The addition of a Dyneema® panel on the right calf protects against nicks from a hanging chainsaw, and upgraded zippers help block sawdust ingress. High-visibility panels on the front and back enhance job site visibility.

Designed for flexibility, these pants incorporate 4-way stretch fabric and a FlexZone seat seam, allowing full range of motion during climbing or ground work. Practical features include an elasticized waist, wide belt loops, and multiple zippered pockets accessible when wearing a harness.

Available in a range of sizes and leg lengths, the Clogger Zero Gen2 Chainsaw Pants deliver reliable protection and breathability without sacrificing mobility—ideal for professionals working in challenging, high-output conditions.



CLOGGER DENIM CHAINSAW TROUSERS

Clogger Denim Men's Chainsaw Trousers combine the familiar look and comfort of classic jeans with advanced chainsaw protection, offering both style and safety for professionals who value performance without compromising appearance. Engineered for all-day wear, these trousers are made from a lightweight yet durable blend that resists abrasion while incorporating built-in stretch for ease of movement during demanding tasks. Ideal for arborists, forestry workers, and landscapers, the Clogger Denims provide discreet protection without the bulk of traditional chainsaw pants, making them well-suited to both fieldwork and public-facing environments. Available in sizes XS to 3XL and a range of leg lengths—standard, long, and short—for an optimal fit. Designed to move with you while keeping you safe, these trousers are a practical and stylish solution for modern outdoor work.



CLOGGER ZERO ARM BANDS

PRODUCT CODE

AP21SA
Small

AP21MA
Medium

AP21LA
Large

The Clogger Arm Protector is designed to provide reliable chainsaw protection for the forearm, ideal for professionals who work in high-risk environments. Made with the same high-quality materials found in Clogger's leg protection gear, these arm guards help reduce the risk of serious injury from accidental contact with a running chainsaw. Lightweight and comfortable for all-day wear, they are sold individually and available in small, medium, or large sizes to ensure a secure fit.





CLOGGER CHAINSAW CHAPS - BUCKLE

PRODUCT CODE

- HCCS**
Small - 950mm
- HCCM**
Medium - 1,000mm
- HCCL**
Large - 1,050mm

Clogger Buckle Chainsaw Chaps are a practical solution for workers who need reliable chainsaw protection without wearing full pants all day. Designed to be worn over work clothes or shorts, these chaps feature quick-release buckle fastenings for easy on and off, especially at the lower leg. The tough nylon outer is water and oil resistant, while Clogger's trusted ARRESTEX protective material provides front-leg protection. High-visibility orange markings and a reflective stripe on the lower leg enhance safety in busy or low-light environments.



CLOGGER CHAINSAW CHAPS - ZIP

PRODUCT CODE

- HCCZS**
Small - 950mm
- HCCZM**
Medium - 1,000mm
- HCCZL**
Large - 1,050mm

Clogger Zipped Chainsaw Chaps are ideal for users needing chainsaw protection for part-time tasks. Designed to be worn over regular workwear or shorts, these chaps feature a robust zip closure on the lower leg for quick and secure fitting. The durable nylon outer is water and oil resistant, while the ARRESTEX protective material guards the front of the legs from chainsaw injury. High-visibility orange markings and a reflective stripe on the lower leg enhance visibility for added safety in the field.

CLOGGER FIRE RETARDANT CHAINSAW CHAPS

PRODUCT CODE

- HCCZPS**
Small - 950mm
- HCCZPM**
Medium - 1,000mm
- HCCZPL**
Large - 1,050mm

Clogger Fire-Resistant Chainsaw Chaps are built for wildland firefighters and forestry professionals who need advanced chainsaw protection in fire-prone environments. Made with Clogger's exclusive Arrestex FR fabric, these chaps offer full fire-resistant performance—from the outer shell to the internal chainsaw protection layers—without compromising on comfort. Lightweight at just 1.1kg (Medium), they feature waist-to-ankle protection, a five-strap system to minimize snagging, and high-vis FR reflective tape for added safety. Certified to NFPA 1977 and rated to 11 cal/cm² arc resistance, these chaps are the modern solution for safe, agile chainsaw work in extreme conditions.



CLOGGER CHAINSAW VESTS

PRODUCT CODE

- HCVRS**
Small - 94cm Chest
- HCVRM**
Medium - 102cm Chest
- HCVRL**
Large - 110cm Chest
- HCVRXL**
Extra Large - 118cm Chest

The Clogger Chainsaw Vest is a must-have for arborists and professionals using chainsaws at height or from elevated platforms. Designed to protect the upper chest and shoulders—key areas exposed during kickback incidents—it features built-in layers of Clogger's exclusive ARRESTEX fabric for reliable chainsaw cut resistance.

Includes hi-vis lime fabric and reflective tape for added visibility in low-light conditions and are equipped with a rugged front zipper for secure fit and internal pockets for convenience on the job. Offered in sizes Small through to XL, this vest combines essential protection with comfort and mobility, making it a critical part of your chainsaw PPE system.





CLOGGER TRIMMER CHAPS

PRODUCT CODE

HCTRIM
One size

Clogger Line Trimmer Chaps are designed to provide reliable protection for your lower legs from flying debris, stones, and other hazards while using line trimmers or brushcutters. Built with a durable outer and a soft inner lining for comfort, these chaps feature elasticized Velcro straps for a secure, adjustable fit. One size fits all, making them a practical choice for both professional and home users seeking safety without sacrificing ease of use.



SNAKESAFE LEGGINGS

PRODUCT CODE

SSG31/S
Small

SSG31/M
Medium

SSG31/L
Large

SSG31/XL
Extra Large

Snakesafe Leggings are purpose-built gaiters designed to provide vital lower leg protection against venomous snake bites, making them an essential piece of PPE for outdoor workers. Covering from knee to ankle, these gaiters have been rigorously tested using five of Australia's most common venomous snakes. In every test, no venom penetrated the fabric, even under magnification, confirming their effectiveness. Ideal for councils, landscapers, and rural workers, Snakesafe Leggings offer peace of mind and compliance with workplace safety standards in snake-prone environments.

AIRFLOW HELMET

PRODUCT CODE

TA570:WH
White

TA570:OR
Orange

The Airflow Helmet is a top-tier safety helmet designed for comfort, durability, and versatility. Its vented ABS plastic shell provides lightweight yet strong protection, making it ideal for extended wear in warm conditions. For high-temperature environments, a polycarbonate version is also available. Featuring accessory slots for hearing and face protection, plus a built-in rain gutter for added comfort, this helmet is engineered for all-day performance. Available in white, and orange.



MAXISAFE FULL FACE MASK

PRODUCT CODE

RCF01

The Maxisafe Full Face Mask is a premium respiratory protection solution designed for comfort, visibility, and durability. Made from high-quality silicone, it offers a secure and comfortable fit with a lightweight, well-balanced design. The fully adjustable harness ensures easy wear, while the scratch-resistant polycarbonate lens provides a wide field of vision. Featuring a simple bayonet filter attachment system and certified to AS/NZS 1716:2012, this low-maintenance mask is ideal for demanding work environments. Packaged in a convenient retail box, with optional tear-off lens covers available.

MAXISAFE PREMIUM GOGGLE

PRODUCT CODE

ESG456
Anti-fog lens

Maxisafe Premium Goggles provide reliable eye protection with excellent comfort and clarity. The adjustable head-strap ensures a secure fit, while the anti-fog lens maintains clear vision in varying conditions. Indirect ventilation helps reduce heat and moisture for extended wear. Ideal for use in construction, manufacturing, or outdoor environments.





PELTOR COMBO SAFETY HELMET

PRODUCT CODE

PRAFP10V4

30dB-rated earmuffs

The Peltor Combo Safety Helmet offers top-tier head, hearing, and face protection in one premium package. It features the ventilated 'Airflow' helmet for cool, comfortable wear, 30dB Peltor earmuffs for high-level hearing protection, and a peaked mesh visor for durable face shielding. This all-in-one solution is ideal for demanding environments where safety and comfort are essential.



MAXISAFE CLEARVIEW VISOR

PRODUCT CODE

EBF454

Anti-fog lens

The Maxisafe Clearview Visor delivers high-impact face protection with crystal-clear visibility. Made from tough polycarbonate, it meets AS/NZS 1337.1:2010 standards for extra high impact resistance. The visor features an anti-fog clear lens, quicklock replacement system, and ratchet-adjustable headgear for a secure, comfortable fit—ideal for extended use in challenging environments.

MAXISAFE FORESTRY KIT

PRODUCT CODE

HFK429

29dB-rated earmuffs

The Maxisafe Forestry Kit is a complete safety solution for forestry and outdoor work. It includes a ventilated airflow helmet for comfort, 29dB-rated earmuffs for hearing protection, and a high-quality nylon mesh visor to shield your face from debris while maintaining clear visibility. Ideal for chainsaw, trimmer, and mower use, this kit ensures reliable head, ear, and face protection in demanding environments.



MAXISAFE MESH VISOR & EARMUFFS

PRODUCT CODE

EMV439

Class 4 earmuffs

The Maxisafe Mesh Visor & Earmuff Combo is a versatile, all-in-one safety solution designed for chainsaw, trimmer, and mower users. Featuring ratchet-adjustable headgear, a replaceable mesh visor, and Class 4 earmuffs, this combo offers reliable face and hearing protection. The rust-resistant components and compatibility with safety glasses, goggles, and respirators make it a durable, adaptable choice for tough outdoor conditions.

MAXISAFE HEADBAND EARMUFFS

PRODUCT CODE

HRE662

26dB-rated earmuffs

The Maxisafe Headband Earmuff delivers high-performance hearing protection with Class 5 SLC80 26dB noise reduction, ideal for noisy industrial environments. Designed for comfort, it features low headband tension for extended wear and Elastex sweat-reducing ear cushions to minimise moisture build-up. A two-point suspension system allows for easy height adjustment and a personalised fit. Fully compliant with AS/NZS 1270:1999 standards, this earmuff is a reliable choice for professionals in construction, manufacturing, and other high-noise settings.



MAXISAFE NECKBAND EARMUFFS

PRODUCT CODE

HRE663
25dB-rated earmuffs

The Maxisafe Neckband Earmuff is a smart solution for those wearing safety caps or full brim hats, offering reliable hearing protection without over-the-head straps. With a secure neckband design and 25dB noise reduction rating, these earmuffs provide effective sound protection while ensuring all-day comfort. Lightweight, durable, and ergonomically designed with soft ear padding, they're ideal for demanding environments where traditional earmuffs may not be practical. A comfortable and convenient choice for hearing safety on the job.



MAXISAFE HELMET EARMUFFS

PRODUCT CODE

HRE646
26dB-rated earmuffs



The Maxisafe Rockman Helmet Earmuff Class 5 delivers top-tier hearing protection for high-noise environments, with a Class 5 rating and 26dB SLC80. Designed for use with safety helmets, it features Elastex™ 3500 sweat-resistant ear cushions and cup-style buffers for long-wear comfort. With three adjustable positions—working, airing, and resting—it suits extended use on the job. Compatible with the Rockman visor holder and compliant with AS/NZS 1270:1999, it's a durable, versatile solution for helmet-mounted hearing protection.

3M PELTOR OPTIME III HARDHAT ATTACHED EARMUFF

PRODUCT CODE

H540P3GS/E
30dB-rated earmuffs

The 3M™ PELTOR™ Optime™ III H540P3GS/E Hard Hat Attached Earmuffs deliver outstanding hearing protection in extreme noise environments like airports and engine rooms. With double-casing technology for reduced resonance and up to 30 dB noise reduction, they ensure high-frequency attenuation. Soft, wide cushions and roomy cups enhance comfort and minimise heat build-up. Helmet-mounted for convenience, they're ideal for professionals needing reliable, high-performance protection.



PELTOR OPTIME III HEADBAND EARMUFF

PRODUCT CODE

H540A
30dB-rated earmuffs



The 3M™ PELTOR™ Optime™ III H540A Headband Earmuff is engineered for high-noise environments, offering up to 30 dB of noise reduction. Ideal for industrial settings, it features advanced double-shell technology to reduce resonance and improve high-frequency attenuation. The soft, wide cushions and spacious ear cups ensure long-wearing comfort. Designed for reliable protection and compatibility with other safety gear, it's a trusted choice for demanding workplaces.

PELTOR OPTIME II HARDHAT ATTACHED EARMUFF

PRODUCT CODE

520P3G/E
31dB-rated earmuffs

The 3M™ PELTOR™ Optime™ II H520P3GS/E Hard Hat Attached Earmuffs provide reliable hearing protection in moderate to high-noise industrial environments. Designed for compatibility with most safety helmets, these earmuffs offer effective noise reduction while maintaining comfort for extended use. Soft ear cushions and a low-profile design help reduce pressure and heat build-up, making them ideal for long shifts. Part of 3M's trusted range of hearing solutions, the Optime II ensures safety without compromising wearability.





EAR PLUGS

PRODUCT CODE

- HEC644**
Corded
- HEU645**
Un-corded

Made from soft, moulded polymer foam, these earplugs provide a superior, comfortable fit and are ideal for extended use. Each pair is individually packaged for hygiene, with corded versions helping to prevent loss. Supplied in a 100-pair wall-mountable dispenser box. Noise attenuation rating: 28dB. Available in corded or un-corded options.



MAXISAFE TWIN FILTER RESPIRATOR

PRODUCT CODE

- R7500S**
Small
- R7500M**
Medium
- R7500L**
Large

The Maxisafe MaxiGuard Silicone Half Mask delivers superior comfort and protection for professional respiratory safety. Made from soft, durable silicone, it features a low-profile twin filter design to reduce breathing resistance and improve balance. A fully adjustable harness ensures a snug, secure fit for all-day wear, while the slim profile maintains a wide field of vision. The bayonet-style connection system makes filter changes quick and secure. Available in small, medium, and large, and certified to AS/NZS 1716:2012 standards. Supplied in retail-ready blister packs.

MAXISAFE NUISANCE DUST MASK

PRODUCT CODE

- RES500**
50 Pack

Maxisafe Nuisance Dust Masks offer lightweight, comfortable protection against non-toxic dust, pollen, and airborne irritants. Ideal for gardening, light DIY projects, and general use, each mask features an adjustable nose bridge for a secure fit. Supplied in a convenient 50-pack, they provide simple and effective everyday dust protection.



MAXISAFE CARBON P2 RESPIRATORS

PRODUCT CODE

- RES505**
10 Pack | With valve

Maxisafe P2 Moulded Respirator with Carbon Filter and Valve offers superior protection against airborne particles and nuisance-level organic vapours. Featuring a pre-moulded design for a secure, comfortable fit across various face shapes, it also includes an exhalation valve for improved breathability and a carbon filter for added odour relief. Ideal for extended wear in dusty or odorous environments.

MAXISAFE P2 CONICAL RESPIRATOR

PRODUCT CODE

- RES514**
10 Pack | With valve
- RES513**
20 Pack | Without valve

Maxisafe P2 Conical Respirators provide reliable protection against mechanically and thermally generated particles. Available in vented (10/box) and non-vented (20/box) options, they feature a pre-formed nose bridge for a secure fit and twin straps for all-day comfort. Certified to AS/NZS 1716, they're ideal for dusty work environments, grinding, sanding, and general respiratory protection.



MAXSAFE ERGOKNEEL HANDY MAT

PRODUCT CODE

MAX-EK02
200mmx400mm

MAXSafe Ergokneel Handy Mat (200x400mm) is a compact, durable kneeling pad designed to reduce knee and lower back strain on hard surfaces. Made from high-quality, petroleum-resistant materials, it offers long-lasting comfort and protection. Lightweight and easy to carry with a built-in handle, it's ideal for tradespeople, gardeners, and anyone working on the move.



SAFEGUARD DISPOSABLE OVERALLS

PRODUCT CODE

S07243333 Small	S07243350 Medium	S07243367 Large	S07243384 Extra Large	S07243401 2x Extra Large
---------------------------	----------------------------	---------------------------	---------------------------------	------------------------------------

Available in sizes Small to 2XL, Safeguard Disposable Overalls are ideal for a wide range of spraying applications. These lightweight, protective coveralls are designed for single use, offering a convenient and hygienic barrier against overspray, dust, and light splashes. Perfect for gardening, pest control, and general maintenance tasks.

FOREMAN BLACK GUMBOOT WITH SAFETY TOE

PRODUCT CODE

FWG902/7 Size 7	FWG902/8 Size 8	FWG902/9 Size 9	FWG902/10 Size 10	FWG902/11 Size 11	FWG902/12 Size 12
---------------------------	---------------------------	---------------------------	-----------------------------	-----------------------------	-----------------------------

Built for tough worksites, the Foreman Black Gumboot delivers durable, waterproof protection with a steel safety toe. Made from high-grade virgin PVC with a nitrile/PVC blend sole, it resists oils, acids, fats, and animal by-products. The deep-lug outsole ensures a strong grip on wet, muddy, and uneven terrain. Ideal for construction, concreting, and mining environments.



MAXISAFE PREMIUM GEL KNEE PAD

PRODUCT CODE

KPE680
Elastic Straps

Designed for all-day comfort and protection, the Maxisafe Professional Gel Knee Pad features anti-compression air-injected gel padding with a supportive foam core. Elastic straps with easy Velcro fasteners ensure a secure, comfortable fit for extended use. Ideal for tradies, landscapers, and DIYers.

REFLECTIVE SAFETY VEST - DAY

PRODUCT CODE

SVYNT Yellow	SVONT Orange
------------------------	------------------------

Stay visible and safe with this high-visibility yellow and orange vest, designed for daytime use. Made from close-woven fabric for added durability, it features reflective strips and secure Velcro fastenings. Available in sizes Small to 2XL. Day compliant only.



REFLECTIVE SAFETY VEST - NIGHT

PRODUCT CODE

SVYAS Yellow	SVOAS Orange
------------------------	------------------------

Designed for both day and night visibility, this close-woven yellow and orange vest features silver reflective tape for added safety in low-light conditions. Durable and practical, it fastens securely and is available in sizes Small to Extra Large.



TEXAS SAFETY GLASSES

PRODUCT CODE

- EBR330**
Clear
- EBR331**
Smoked

Affordable and reliable, Texas Safety Glasses offer all-day protection with a comfortable wraparound design. Certified to AS/NZS 1337.1:2010 standards, they're available with clear or smoked lenses, both providing 99.9% UV protection. Anti-scratch and anti-fog coatings ensure clear vision in any environment.



KANSAS SAFETY GLASSES

PRODUCT CODE

- EKA304**
Clear
- EKA305**
Smoked



Designed for comfort and performance, Kansas Safety Glasses feature an aerodynamic frame with soft nose pads and arm tips for a secure fit. Ultralight and certified to AS/NZS 1337.1:2010, they provide 99.9% UV protection, anti-scratch and anti-fog lenses, and a wide 180° distortion-free field of vision.

NAVIGATOR SAFETY GLASSES

PRODUCT CODE

- ENA341**
Smoked

Stylish and protective, Navigator Safety Glasses combine ultralight comfort with medium impact resistance. Featuring smoked, anti-scratch and anti-fog lenses, they offer 99.9% UV protection and are certified to AS/NZS 1337.1:2010 for reliable eye safety on the job.



DENVER SAFETY GLASSES

PRODUCT CODE

- EDE307**
Non-polarised
- EDE308**
Polarised



The DENVER Premium Safety Glasses feature a sleek black polycarbonate frame with smoke lenses for medium impact protection. Anti-scratch, anti-fog coated and UV-resistant, they provide 99.9% UV filtration. Designed for all-day comfort with a moulded silicone nose piece and soft rubber arm tips. Certified to AS/NZS 1337.1:2010.

AUSCREEN 50+ SUNSCREEN

PRODUCT CODE

- SS1**
1L

Auscreen 50+ Sunscreen offers broad-spectrum UVA/UVB protection in a non-greasy, quick-absorbing formula. Enriched with Vitamin E to hydrate and soothe dry skin, it's ideal for everyday family use. Water-resistant for up to 4 hours, it won't sting eyes or leave a sticky residue—perfect for outdoor and water activities.



AMI WADERS

PRODUCT CODE

- TF8046**
Size 6
- TF8047**
Size 7
- TF8048**
Size 8
- TF8049**
Size 9
- TF80410**
Size 10
- TF80411**
Size 11
- TF80412**
Size 12
- TF80414**
Size 14



Durable and waterproof, AMI Waders are ideal for pond maintenance, lake cleanouts, and waterway revegetation work. Designed for comfort and reliability in wet environments, they are available in boot sizes 6–12.

RED KNIGHT GRIPPER GLOVE

PRODUCT CODE

GNL156/7 Small	GNL156/8 Medium	GNL156/9 Large	GNL156/10 Extra Large	GNL156/11 2x Extra Large
--------------------------	---------------------------	--------------------------	---------------------------------	------------------------------------

The Red Knight Gripper Glove is a high-performance, multi-purpose glove designed for excellent grip, flexibility, and durability. Featuring Gripmaster Latex Palm Coating Technology, it ensures a secure hold and superior handling precision. Made from a 13-gauge seamless nylon/lycra blend, it offers comfort, breathability, and touch screen compatibility. With strong abrasion and puncture resistance, it's ideal for use in agriculture, construction, logistics, automotive, and more.



WHITE KNIGHT NITRILE GLOVE

PRODUCT CODE

GNF12407 Small	GNF12408 Medium	GNF12409 Large	GNF12410 Extra Large
--------------------------	---------------------------	--------------------------	--------------------------------

White Knight Nitrile Gloves offer a snug, second-skin fit without compromising touch sensitivity. Tough yet flexible, they provide excellent grip and UV protection. Ideal for precision tasks and all-day comfort. Available in sizes S, M, L, and XL.

SUPER GRIP GARDENING GLOVES

PRODUCT CODE

GGL10607 Small	GGL10608 Medium	GGL10609 Large	GGL10610 Extra Large	GGL10611 2x Extra Large
--------------------------	---------------------------	--------------------------	--------------------------------	-----------------------------------

Super Grip Gardening Gloves are designed for comfort, protection, and performance. Featuring a breathable stretch knit construction and a super grip coating on the palm and fingers, they offer excellent grip and cut resistance. Machine washable and available in sizes Small to 2XL, they're perfect for all your gardening tasks.



LITEFLEX PU GLOVE

PRODUCT CODE

GNP13607 Small	GNP13608 Medium	GNP13609 Large	GNP13610 Extra Large	GNP13611 2x Extra Large
--------------------------	---------------------------	--------------------------	--------------------------------	-----------------------------------

The LiteFlex PU Glove offers superior dexterity and control with its ultra-light nylon shell, while the grey polyurethane-coated palm delivers excellent abrasion resistance. Perfect for landscaping and construction work, these gloves combine comfort and durability. Available in sizes S to 2XL.

BLACK KNIGHT GRIPMASTER GLOVE

PRODUCT CODE

GNN19207 Small	GNN19208 Medium	GNN19209 Large	GNN19210 Extra Large
--------------------------	---------------------------	--------------------------	--------------------------------

The Black Knight Gripmaster Glove features Maxisafe's advanced Gripmaster® coating for outstanding grip in wet, oily, or dry conditions. Ideal for agriculture, mining, general handling, and materials work, it offers a close, breathable fit with a 13-gauge lycra/nylon shell. The multi-layered coating repels water and blocks oil penetration, while Anti-Bac treatment fights bacteria and odour. With no internal strikethrough and full machine washability, these gloves deliver comfort, hygiene, and long-lasting performance.





THINSULATE LINED RIGGERS GLOVES

PRODUCT CODE

- GRL14409**
Medium
- GRL14410**
Large
- GRL14411**
Extra Large

Thinsulate Lined Riggers Gloves are premium thermal work gloves made from 'A' Grade leather and lined with 3M Thinsulate for superior warmth in cold conditions. Reinforced stitching at the thumb adds durability, making them ideal for tough outdoor jobs. Available in M, L, and XL.



COWSKIN RIGGERS GLOVE

PRODUCT CODE

- GRC14308**
Small
- GRC14309**
Medium
- GRC14310**
Large
- GRC14311**
Extra Large
- GRC14312**
2x Extra Large

The Cowskin Riggers Glove is crafted from premium 'A' grade soft cow grain leather for superior comfort and durability. Ideal for tough work environments, these high-quality gloves offer excellent wear resistance and a comfortable fit. Available in sizes Small through 2XL.

LATEX DISPOSABLE GLOVES

PRODUCT CODE

- GLP200/S**
Small
- GLP200/M**
Medium
- GLP200/L**
Large
- GLP200/XL**
Extra Large

Latex Disposable Gloves provide a cost-effective solution for general-purpose hand protection. Made from lightly powdered latex rubber for easy donning, they offer flexibility and a secure fit. Ideal for various tasks, they come in boxes of 100 and are available in sizes S, M, L, and XL.



NITRILE DISPOSABLE GLOVE

PRODUCT CODE

- GNU221S**
Small
- GNU221M**
Medium
- GNU221L**
Large
- GNU221XL**
Extra Large

Premium quality Nitrile Disposable Gloves made from industrial-grade synthetic nitrile for excellent chemical, oil, and abrasion resistance. Featuring textured fingertips for improved grip, they are ideal for various applications. Available in sizes S, M, L, and XL. Box of 100 gloves.

MAXISAFE BLACK SHIELD HEAVY DUTY NITRILE GLOVES

PRODUCT CODE

- GNB218L**
Large 100/pack

Maxisafe Black Shield Heavy Duty Nitrile Gloves provide tough, chemical-resistant protection ideal for automotive, mechanical, and maintenance work. Certified against Fentanyl, these breathable, low-sweat gloves ensure comfort during extended use. Pack of 100, size Large.



MAXISAFE INTERLOCK POLY/COTTON GLOVE

PRODUCT CODE

- GCI100/L**
Small (Women's)
- GCI100/M**
Large (Men's)

The Maxisafe Interlock Poly/Cotton Glove is a dependable choice for light-duty tasks in manufacturing, engineering, and assembly. Made with a durable poly/cotton interlock liner, these gloves offer excellent breathability and comfort for extended wear. Ideal for general handling where dexterity and lightweight protection are key.

LONG PRUNING GAUNTLET

PRODUCT CODE

GLG01XS
Extra Small

GLG01S
Small

GLG01M
Medium

GLG01L
Large

GLG01XL
Extra Large

GLG01XXL
2x Extra Large

The Long Thorn Proof Pruning Gauntlet by Morris Outside is built for serious garden protection. Made from supple yet durable goat leather, it offers excellent sensitivity and strength. Features include an adjustable Velcro closure at the wrist and elbow, double-layered palm and thumb for added durability, and tough split leather forearm guards. Ideal for thorny pruning and heavy-duty gardening.



G-FORCE CHEMBARRIER GLOVE

PRODUCT CODE

GNN20308
Medium

GNN20309
Large

GNN20310
Extra Large

The G-Force Chembarrier Glove delivers reliable chemical resistance and grip for high-risk environments. Featuring a nitrile water-based and PU foam palm coating, it provides excellent control, dexterity, and a secure non-slip grip in wet or dry conditions. Ideal for use in chemical handling, mining, transport, petrochemical, gas, fishing, and aquaculture industries, these gloves offer targeted protection without compromising flexibility or comfort.

MAXISAFE PVC GAUNTLETS

PRODUCT CODE

GPR121
27cm

GPR122
45cm

Maxisafe PVC Gauntlets provide reliable protection against chemicals, solvents, and moisture, making them ideal for use in damp environments or when handling sprays. Featuring an interlock lining for added comfort, they are available in 27cm and 45cm lengths to suit various tasks and preferences.



MAXISAFE GREEN NITRILE CHEMICAL GLOVE

PRODUCT CODE

GNF127/7
Small

FWG902/8
Medium

GNF127/9
Large

GNF127/10
Extra Large

The Maxisafe Green Nitrile Glove offers strong chemical and abrasion resistance, ideal for industrial, laboratory, and food handling applications. Made from 100% nitrile with a textured palm for a secure grip, it provides 33cm of extended protection. A flocked lining enhances comfort for longer wear, while individual packaging ensures hygiene. Perfect for handling oils, solvents, and cleaning agents.

MAXISAFE CUT PROOF GLOVES

PRODUCT CODE

GKH19607
Small

GKH19608
Medium

GKH19609
Large

GKH19610
Extra Large

GKH19611
2x Extra Large

Maxisafe Cut Proof Gloves are built for tough tasks like handling and sharpening wood chipper blades. Featuring a high-grip Super Grip coating and Kenima reinforced woven fabric for superior cut resistance, these gloves offer excellent protection without sacrificing dexterity. Ideal for professionals needing durable, secure hand protection in high-risk environments.





G-FORCE ANTI-VIBRATION GLOVES

PRODUCT CODE

- GMG293/M**
Medium
- GMG293/L**
Large
- GMG293/XL**
Extra Large

G-Force Anti-Vibration Gloves are designed to protect hands during heavy-duty tasks involving power, pneumatic, or vibrating tools. Made from premium A-grade leather, these gloves feature gel padding in the wrist, palm, and fingers to reduce vibration and enhance comfort. The breathable neoprene back, reinforced thumb crutch, and Velcro wrist fastener ensure a secure and flexible fit. Rated Cut Level D (EN388:2016), they're ideal for mining, roadwork, horticulture, and construction. Available in Medium, Large, and X-Large sizes.



G-FORCE MECHANICS SYNTHETIC GLOVE

PRODUCT CODE

- GMA11310**
Large
- GMA11311**
Extra Large

The G-Force Mechanics Synthetic Glove features a durable one-piece synthetic leather palm with foam padding for added protection and comfort. Reinforced for high-wear tasks, these gloves are ideal for mechanics, construction, and general trade work, offering superior grip, durability, and flexibility in demanding environments.

G-FORCE LEATHER MECHANICS GLOVE

PRODUCT CODE

- GML15808**
Small
- GML15809**
Medium
- GML15810**
Large
- GML15811**
Extra Large

The G-Force Leather Mechanics Glove offers premium protection and dexterity for demanding tasks. Featuring a grain leather palm, elastine back, and neoprene knuckle bar, it delivers comfort, flexibility, and breathability. A Velcro wrist strap ensures a secure fit, while ventilated fourchettes improve airflow. Certified to EN388:2016 - 3 3 2 B, it's ideal for construction, rigging, steel and rope handling, automotive work, and power tool operations.



EXTREME PROTECTION GLOVE

PRODUCT CODE

- GMX28309**
Medium
- GMX28310**
Large
- GMX28311**
Extra Large
- GMX28312**
2x Extra Large

The Extreme Protection Glove offers superior impact protection with unique padded reinforcement and a durable palm membrane for exceptional grip control. Designed for comfort and safety, it features a secure Velcro wrist fastener and high-visibility reflective tape for added visibility in low-light conditions.

G-FORCE FINGERLESS ANTI-VIBRATION MECHANICS GLOVES

PRODUCT CODE

- GMG29409**
Large

Crafted from premium A-grade leather, these fingerless mechanics gloves deliver durability, comfort, and protection. Gel padding in the wrist, palm, and fingers absorbs vibration and reduces fatigue, while the breathable neoprene back keeps hands cool. Reinforced thumb crutch adds extra durability in high-wear areas—ideal for high-performance tasks requiring dexterity and cushioning.





HEAVY DUTY WORK GLOVE

PRODUCT CODE

GLE147

Heavy Duty Work Gloves are built for tough tasks, featuring durable cow split leather with reinforced palm, thumb, forefinger, and a protective knuckle bar. The rubberized safety cuff offers added wrist protection, making these gloves an excellent choice for general-purpose industrial and outdoor work.

GENERAL PURPOSE GLOVE

PRODUCT CODE

GLC145

One Size

The General Purpose Glove is a cost-effective solution that doesn't compromise on quality. Featuring a durable chrome-reinforced palm and knuckle bar for added protection, it also includes a breathable cotton back for comfort during extended wear. Ideal for general trade and manual tasks.



MAXISAFE GLOVE CLIP

PRODUCT CODE

GGG115-0

The Maxisafe Glove Clip is a practical, high-visibility solution for keeping your gloves and essential gear secure and within easy reach. Designed with interlocking teeth and a breakaway safety feature, it attaches easily to your belt or clothing, holding up to 5kg. Ideal for gloves, earmuffs, or helmets, it helps reduce glove loss and promotes safety and efficiency on the job.

RHINOWELD

GABION STRUCTURES

Firewise by design

When filled with natural rock or recycled concrete, Rhinoweld systems form a non-combustible structure that helps reduce fuel load in the landscape. Unlike timber or other combustible materials, gabions contribute to ember-resistant boundary treatments and support defensible space planning in bushfire-conscious design.

A resilient solution where it matters most.



Strong & Durable

Manufactured from heavy-duty welded steel mesh, Rhinoweld gabions are engineered for structural integrity and long service life. Suitable for residential, commercial and public applications, they are built to withstand harsh Australian conditions without compromising on appearance.

Strength that performs. Durability you can trust.

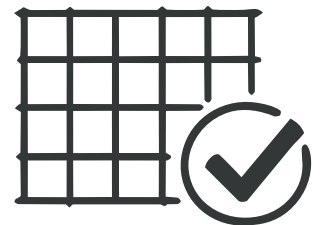

Wildlife Habitat Built In

Rhinoweld gabions do more than retain soil or define space – they create opportunity for life. The natural voids within stone infill form protective cavities that provide shelter for insects and reptiles, offer cool refuge during extreme heat, and can even act as safe havens during fires.

In a changing climate, resilient landscapes must support both people and biodiversity.



Recycled Materials. Responsible Design.

Rhinoweld systems are compatible with recycled concrete, reclaimed stone and locally sourced natural rock, helping reduce construction waste and minimise environmental impact. Their long service life further lowers lifecycle costs and resource use over time.

Sustainable in material. Responsible in design.

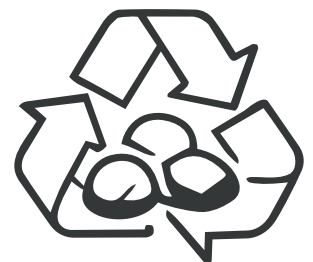

**Firewise Structure. Wildlife Refuge.
Sustainable Strength**



StrataGreen

...grow with us

5 Barrel Way Canning Vale,
Western Australia 6155



sales@stratagreen.com.au



stratagreen.com.au



1300 866 367

