



BATTERY MODULE

- Two mounting options:
DIN rail or panel/ wall mounting
- Small mounting footprint
- Easy access to the terminals and the fuse
- Heavy duty fuse holder and spare fuse included
- 3 year warranty, except for batteries, which are considered a service part.

PRODUCT DESCRIPTION

The UZK12.071 battery module utilizes one non spillable maintenance-free VRLA lead-acid battery, which is assembled in a package with all wiring and fusing included.

The battery module is available in two different options. It can be ordered as UZK-module with a battery or as UZO-module without a battery which can be installed at a later date to avoid outdated batteries.

The battery module can either be mounted on a DIN rail or be screwed on a flat surface.

SHORT-FORM DATA

Nominal voltage	DC 12V	
Nominal battery capacity	7Ah	
Nominal battery life	3 to 5 years	According EUROBAT
Battery current	Max. 30A	Discharging current
	Max. 1.8A	Charging current
Recommended charging voltage	13.9V	At +10°C
	13.75V	At +20°C
	13.6V	At +30°C
	13.45V	At +40°C
Self-discharge rate	3%/month	At +20°C
Battery fuse	30A	ATOF® 287 030 from Littelfuse
Temperature range	-10°C to +40°C	For charging
	-15°C to +50°C	For discharging
Size (WxHxD)	155x124x112mm	WxHxD
Weight	3300g	For UZK12.071
	600g	For UZO12.07

ORDER NUMBERS

Battery Module UZK12.071	Battery module with assembled batteries
UZO12.07	Battery module without assembled batteries
UZB12.071	Battery replacement 12V, 7Ah

MAIN APPROVALS

For details and the complete approval list, see chapter 10.

IECEX

IECEX

DNV
DNV.COM/AF

Marine



ATEX

ABS

Marine



Class I Div. 2

INDEX

	Page		Page
1. Intended Use	3	9. Protection Features	7
2. Instructions for Disposal of the Batteries.....	3	10. Approved, Fulfilled or Tested Standards.....	8
3. Instructions for Battery Storage	3	11. Regulatory Product Compliance	9
4. Installation Instructions	3	12. Physical Dimensions and Weight	10
5. Installation Instructions Hazardous Locations ...	4	13. Wall/ Panel Mounting	11
6. Instructions for Replacing Batteries	5	14. Recommendations for a Long Battery Life	12
7. Environment.....	6	15. Mounting Orientations	13
8. Terminals and Wiring.....	6		

The information given in this document is correct to the best of our knowledge and experience at the time of publication. If not expressly agreed otherwise, this information does not represent a warranty in the legal sense of the word. As the state of our knowledge and experience is constantly changing, the information in this data sheet is subject to revision. We therefore kindly ask you to always use the latest issue of this document (available under www.pulspower.com).

No part of this document may be reproduced or utilized in any form without our prior permission in writing.



WARNING

Risk of electrical shock, fire, personal injury or death.

- Turn power off before working on the device and protect against inadvertent re-powering.
- Do not open, modify or repair the device.
- Use caution to prevent any foreign objects from entering into the housing.
- Do not use in wet locations or in areas where moisture or condensation can be expected.
- Do not touch during power-on, and immediately after power-off. Hot surface may cause burns.

1. INTENDED USE

This device is designed for installation in an enclosure and is intended for commercial use, such as in industrial control, process control, monitoring and measurement equipment or the like.

Do not use this device in equipment where malfunction may cause severe personal injury or threaten human life.

2. INSTRUCTIONS FOR DISPOSAL OF THE BATTERIES

Always dispose batteries through a recycling organization. Optionally, batteries can be returned to the supplier or the battery manufacturer. Batteries must be completely discharged before recycling.

CAUTION: The unit contains wet cell batteries. Ventilation of the installation room in accordance with the rules of Canadian Electrical Code, part 1 is required if used in Canada.

3. INSTRUCTIONS FOR BATTERY STORAGE

Do not store batteries or battery modules at temperatures higher than 25°C or performance and lifetime may change. Before initial use, check the last charging which is marked on the battery. If it is older than 9 months, replace the battery.

Do not store batteries longer than 9 months without charging or performance and lifetime may change. Every 9 months or whenever the open circuit voltage (OCV) falls below 12.6V, the battery module should be charged. Apply a charging voltage of 13.8V (at 25°C) for 72 hours. Batteries with an OCV below 12V should be disposed.

4. INSTALLATION INSTRUCTIONS

This device may only be installed and put into operation by qualified personnel.

This device does not contain serviceable parts, except the fuse or replacement battery. If malfunction should occur during installation or operation, first check the fuse and battery for proper functionality. If the unit is damaged or if the malfunction continues, immediately turn power off and send device to the factory for inspection.

Do not install the battery fuse until the installation work is complete.

Replacement fuses must be of the same type or an UL listed fuse with the same nominal value and characteristics.

Do not store batteries or battery modules at temperatures higher than 25°C or performance and lifetime may change.

Before initial use, check the last charging which is marked on the battery. If it is older than 9 months, replace the battery.

Do not short-circuit the battery poles or power wires and always check correct battery polarity.

Mount the device onto a heavy-duty DIN rail or screw it securely on a flat surface. Before mounting the unit on a flat surface, detach the DIN rail slider (remove the plastic lock mechanism by using a flat-blade screwdriver and move the lock downwards while pushing the plastic slide upwards at the same time) and the two aluminum DIN rail brackets (Torx T10 screwdriver).

Do not install the battery module upside down.

Install the device in a cool area inside an enclosure providing protection against electrical, mechanical and fire hazards. Ensure sufficient ventilation by following the requirements of the EN 50272-2.

The device is designed for pollution degree 2 areas in controlled environments. No condensation or frost allowed.

The enclosure of the device provides a degree of protection of IP00.

Do not use batteries other than the original batteries supplied by the manufacturer to avoid conflicts with agency approvals.

The maximum surrounding air temperature is +50°C (+122°F). The operational temperature is the same as the ambient or surrounding air temperature and is defined 2cm below the device. Charging is allowed up to +40°C.

Frequently charging below +5°C reduces the lifetime of the battery.

The device is designed to operate in areas between 5% and 95% relative humidity.

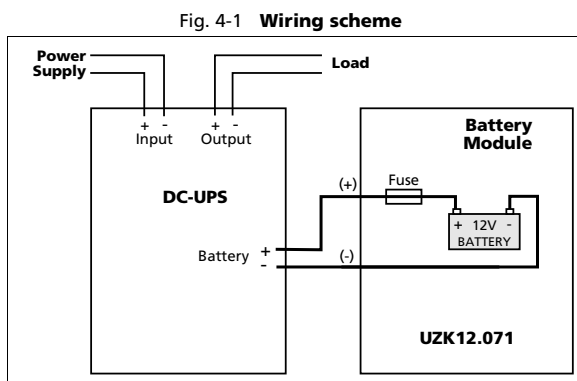

5. INSTALLATION INSTRUCTIONS HAZARDOUS LOCATIONS

Instructions for Use in Hazardous Location Areas

Units which are marked with "Class I Div 2" are suitable for use in Class I Division 2 Groups A, B, C, D locations.

Units which are marked with II 3G Ex nA IIC T4 Gc are suitable for use in Group II Category 3 (Zone 2) environments and are evaluated according to EN 60079-0 and EN 60079-15.

WARNING EXPLOSION HAZARDS!

Substitution of components may impair suitability for this environment.

Do not use batteries other than the original batteries supplied by PULS (UZB12.071 or UZB12.261) or batteries, which are approved according to EN/ IEC 60079-7.

Do not disconnect the unit, remove or insert the fuse unless power has been switched off or the area is known to be non-hazardous. A suitable enclosure must be provided for the end product which has a minimum protection of IP23 and fulfils the requirements of the EN 60079-15. Sufficient ventilation must be ensured in the final installation.

6. INSTRUCTIONS FOR REPLACING BATTERIES

Batteries need to be replaced periodically. The time interval depends on the ambient temperature in which the battery is used and on the number and depth of discharge cycles. In a typical application it is recommended to replace the batteries at least every 2 years.

Disconnect battery fuse before replacing the battery.

Regarding disposal of used batteries see chapter 2.

Fig. 6-1 Replacing the battery

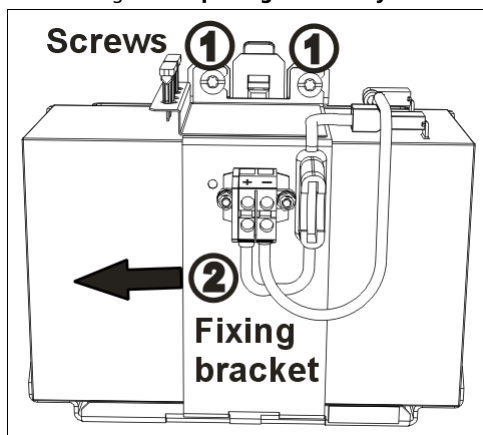

To replace battery:

- 1) Loosen screws (1) with only one turn.
(Use a flat-blade or Torx T20 screwdriver)
- 2) Slide the mounting bracket (2) sideways.
- 3) Tilt the mounting bracket to the front and take it off.
- 4) Unplug the battery terminals.
- 5) Remove the battery.
- 6) To insert the new battery, use same procedure vice versa.

7. ENVIRONMENT

Operational temperature *)	-10°C to +40°C (14°F to 104°F)	For charging Frequently charging below +5°C (41°F) reduced the lifetime of the battery
	-15°C to +50°C (5°F to 122°F)	For discharging
Storage temperature	-20°C to +50°C (-4°F to 122°F)	For storage and transportation Recommendation: Do not store at temperatures higher than 25°C or performance and lifetime may change.
Humidity	5 to 95% r.h.	IEC 60068-2-30 Do not energize while condensation is present
Vibration sinusoidal	±4mm at 16.7Hz fixed frequency for 1hour	Vibration in vertical mounting orientation according to IEC/EN 61056-1
Shock	free fall from 20cm onto a wooden floor	Shock with bottom down orientation according to IEC/EN 61056-1
Altitude	0 to 6000m (0 to 20 000ft)	
Degree of pollution	2	According to IEC 62477-1, not conductive

*) Operational temperature is the same as the ambient temperature and is defined as the air temperature 2cm below the unit.

8. TERMINALS AND WIRING

The terminals are IP20 Finger safe constructed and suitable for field- and factory wiring.

Power terminals	
Type	Screw terminals
Maximal wire size, solid wire	4mm ²
Maximal wire size, stranded wire	4mm ²
American Wire Gauge	AWG 12-10
Maximal wire diameter	3.5mm (including ferrules)
Wire stripping length	7mm
Screwdriver	Slotted 3.5x0.5mm
Recommended tightening torque	0.5Nm







Instructions:

- a) Follow national installation codes and installation regulations!
- b) Ensure that all strands of a stranded wire enter the terminal connection!
- c) Unused terminal compartments should be securely tightened.
- d) Ferrules are allowed.

9. PROTECTION FEATURES

Degree of protection	IP00	According to EN/IEC 60529
Class of protection	III	According to EN/IEC 61140
Internal input fuse	30A	DC-Fuse (blade type) ATOF® 287 030 from Littelfuse Replacement fuses must be of the same type or an UL listed fuse with the same nominal value and characteristics.
Isolation	1100Vac	Isolation voltage between power to chassis

10. APPROVED, FULFILLED OR TESTED STANDARDS

ATEX		Agency Certificate (Bureau Veritas) EN 60079-0 Explosive atmospheres - General requirements EN 60079-7 Equipment protection by type of protection "e" Certificate: EPS 15 ATEX 1 025 X Temperature Code: T4 Type of Protection: ec
IECEX		IECEX Certificate IEC 60079-0 Explosive atmospheres - General requirements IEC 60079-7 Equipment protection by type of protection "e" Certificate: IECEX EPS 15.0049X Temperature Code: T4 Type of Protection: ec
Class I Div 2		CSA Certificate Power Supplies for Hazardous Location Applicable for Canada and US CSA Class: 5318-01 (Canada), 5318-81 (USA) Temperature Code: T4 Groups: A, B, C and D
Marine (DNV)		DNV Certificate DNV Type approved product Certificate: TAA00001ST
Marine (ABS)		ABS Design Assessment Certificate ABS (American Bureau of Shipment) assessed product Certificate: 22-2231447-PDA
UL 1989 (UZK12.071)		Vendor Certificate Standard for Standby Batteries UL94: HB
VDMA 24364		Paint Wetting Impairment Substances Test (or LABS-Test) Tested for Zone 2 and test class C1 according to VDMA 24364-C1-L/W for solvents and water-based paints

11. REGULATORY PRODUCT COMPLIANCE

EU Declaration of Conformity



The CE mark indicates conformance with the
 - EMC directive
 - ATEX directive
 - RoHS directive

REACH Regulation (EU)



Manufacturer's Statement
 EU regulation regarding the Registration, Evaluation, Authorisation and Restriction of Chemicals (REACH) fulfilled.

WEEE Regulation



Manufacturer's Declaration
 EU Regulation on Waste Electrical and Electronic Equipment
 Registered as business to business (B2B) products.
 EU Regulation 2012/19/EU

CCC



CCC Certificate
 China Compulsory Certification (CNCA-C23-01:2019)
 Certificate for devices made in Suzhou/China (PULS Electronics):
 2021122303114843
 Certificate for devices made in Chomutov/Czech Republic (PULS investiční): 2021122303114844
 CCC-Ex

12. PHYSICAL DIMENSIONS AND WEIGHT

Width	155mm
Height	124mm'
Depth	112mm'

For DIN rail mounting:
The DIN rail depth must be added to the unit depth to calculate the total required installation depth.

Weight	3300g	For UZK12.071
	600g	For UZO12.07

Bracket material	Zinc-plated steel
------------------	-------------------

Fig. 12-1 **Front view**

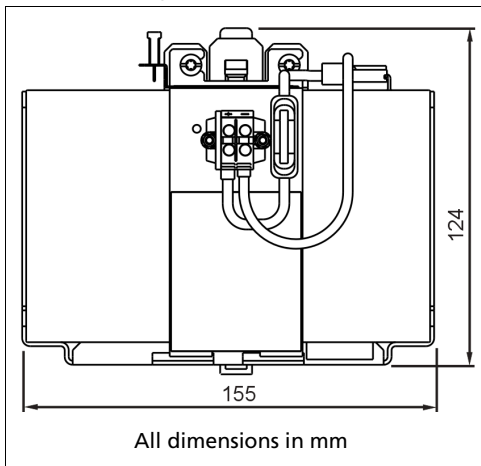

Fig. 12-2 **Side view**

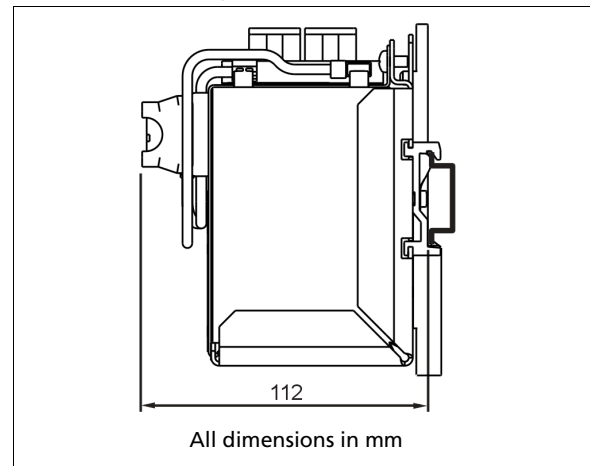
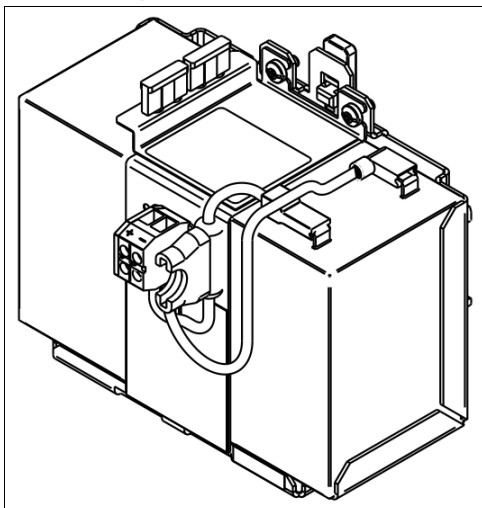

Fig. 12-3 **Isometric view**



13. WALL/PANEL MOUNTING

Panel/wall mounting is possible by detaching the DIN rail brackets

Fig. 13-1 Panel/ wall mounting – Removing the aluminium brackets and plastic slide

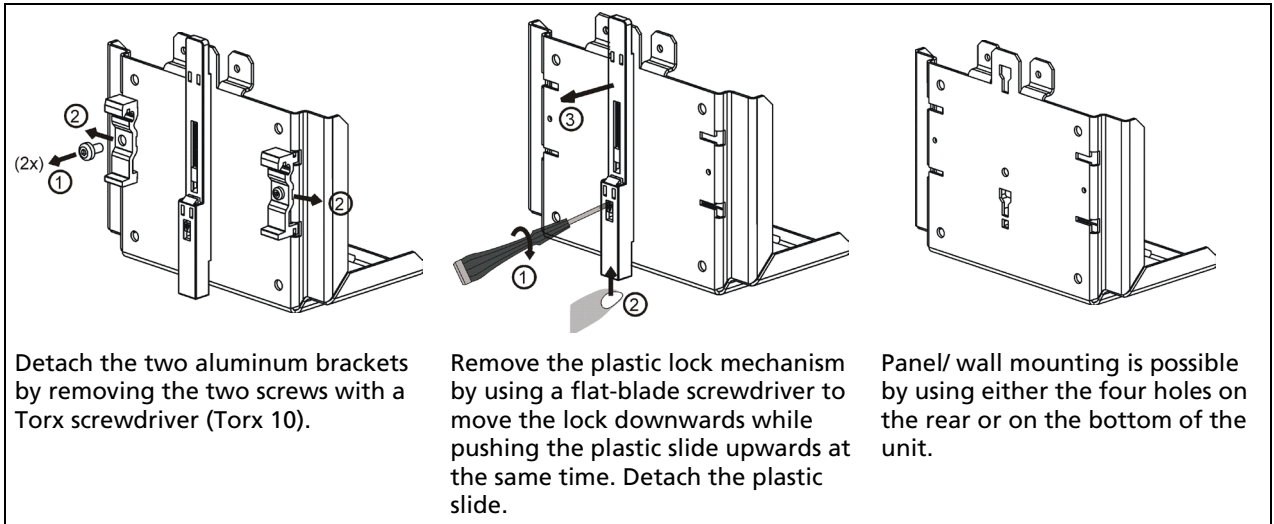

Fig. 13-2 Hole pattern for wall mount

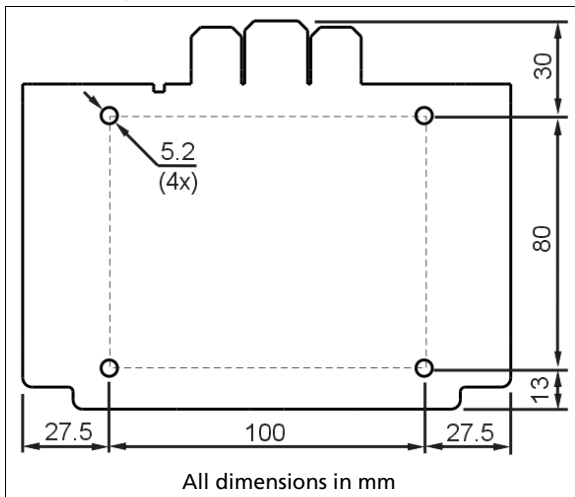
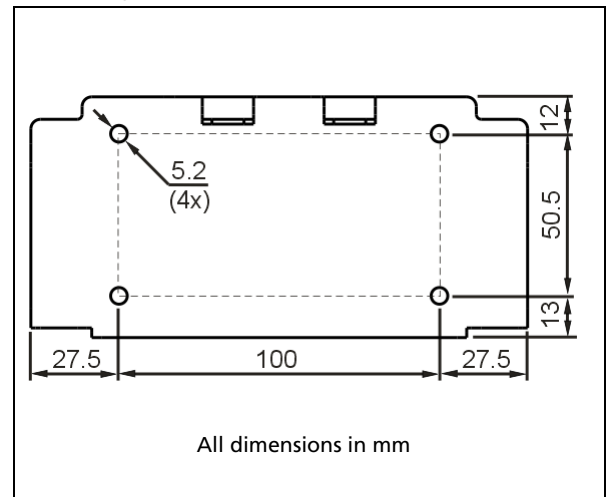

Fig. 13-3 Hole pattern for bottom mount



14. RECOMMENDATIONS FOR A LONG BATTERY LIFE

Temperature:

The temperature has the most impact on the service life. The hotter the temperature, the earlier the wear-out phase of the battery begins. The wear-out results in a degradation of battery capacity. Place the battery module in a cool location, e.g. near the bottom of the control cabinet. Do not place the battery module near heat generating devices. Do not overcharge batteries!

Fig. 14-1 **Service life (according to EUROBAT) vs. ambient temperature, typ.**

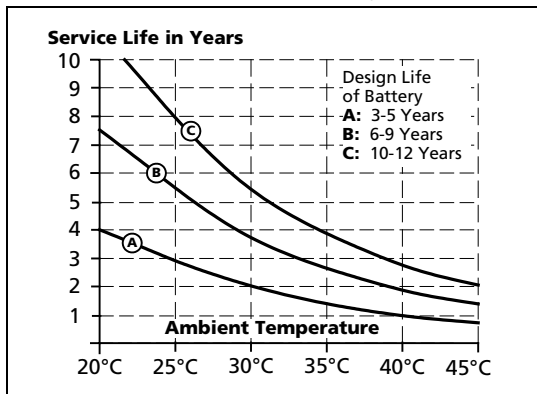

Number of discharge cycles and depth of discharge:

Do not discharge batteries more than necessary. Set buffer time limiter to the required buffer time. The number, as well as the depth of discharging cycles is limited. A replacement of the battery might be necessary earlier.

When choosing the battery capacity, always try to get the next higher capacity than required. The depth of discharge reduces the service life of the battery and limits the number of cycles.

Fig. 14-2 **Battery degradation vs. discharging cycles, typ.**

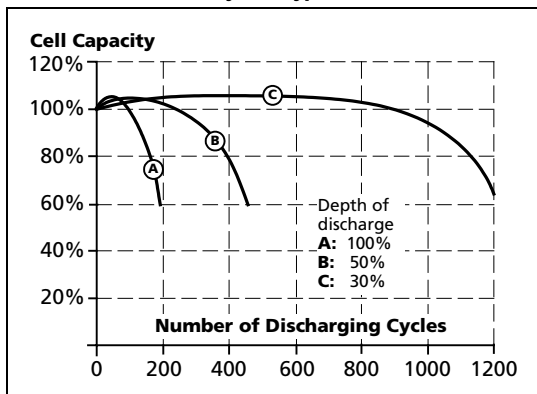

Store batteries fully charged

Do not store discharged batteries. Keep batteries fully charged!

Charge retention is important to get the longest battery life. Stored batteries which are not fully charged age faster than charged batteries. Batteries which are not in use should be recharged at least once a year. The higher the ambient temperature, the shorter the charging interval. At storage temperatures higher than 30°C, recharging should be done at least every nine months.

15. MOUNTING ORIENTATIONS

The standard mounting orientation is the vertical installation onto a flat surface.

Fig. 15-1 **Standard mounting orientation**

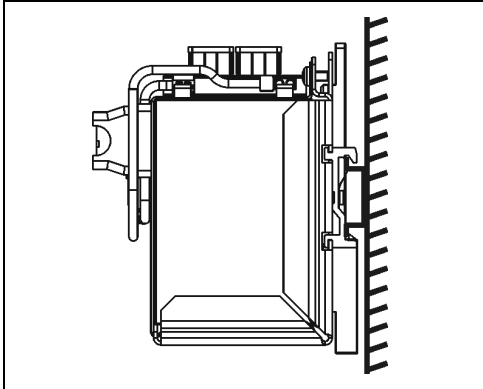

The following mounting orientations are also allowed:

Fig. 15-2 **Allowed mounting orientations**

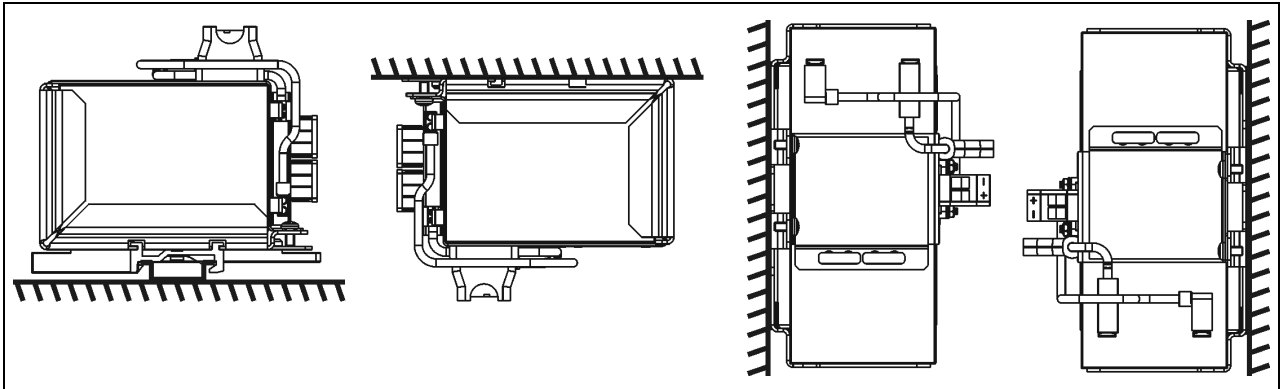

Do not use the battery module in an upside down position:

Fig. 15-3 **Forbidden mounting orientation**

