

FitStay 1

Indulge your guests in a wellness oasis with the FitStay 1 Outdoor Fitness Park. Exclusively designed for hotels, this outdoor fitness facility is a testament to luxury and sophistication. From cardio machines to strength training equipment, FitStay 1 provides an unparalleled fitness journey where guests can invigorate their bodies while immersing themselves in the serene ambiance of your hotel.

Attributes

| | |
|--------------|----------------------|
| Product code | 1-3-257 |
| Certificate | EN 16630, ASTM F3101 |
| Age group | 14 + years |
| Designed for | Hotels |
| Capacity | 16 people |
| Fall height | 3.1 ft |

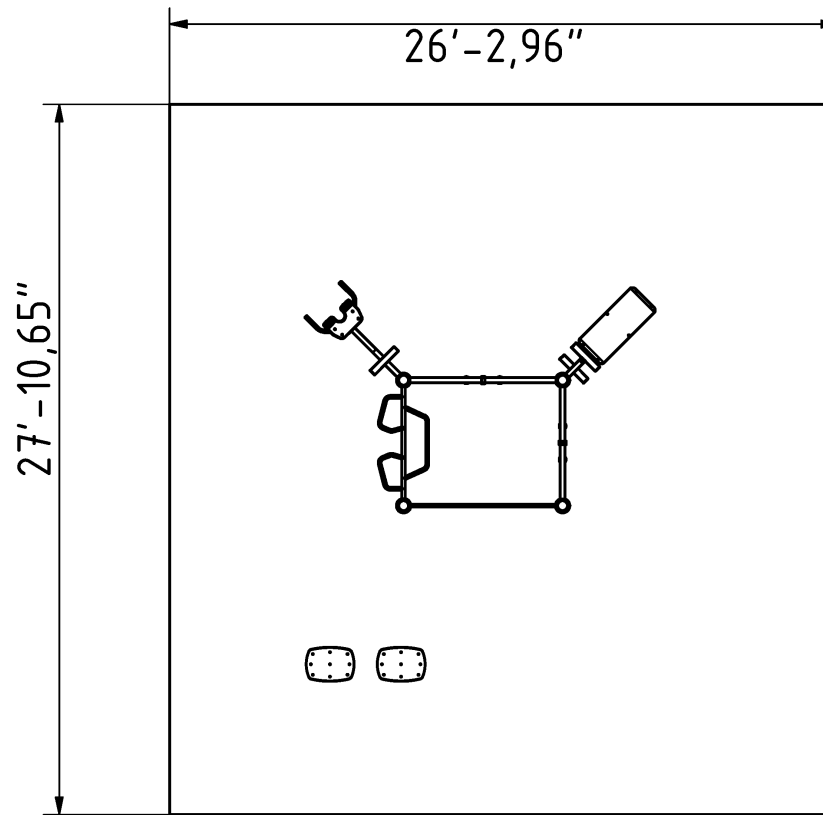

Technical specification

Anchoring option
 Net weight
 Material
 Anti-corrosion possibility
 Total Area
 Color options
 For more color options, discuss with your sales representative.

In-ground or surface
 781.5 lbs
 S235
 Galvanized or EPD
 731.7 ft²



Warranty

Structure
 Steel
 Paint
 Plastic
 Rubber
 Moving parts
 Detailed information in the warranty document

25 years
 15 years
 2 years
 5-10 years
 1-3 years
 2 years