



LAWSON HOUSE

Historic Preservation Meets Affordable Housing



SUPPORTIVE HOUSING IN THE JEWEL OF THE GOLD COAST



CLIENT

Holsten Real Estate Development
Holsten Human Capital Development

PROJECT AREA

250,000 GSF

PROJECT COST

\$122,000,000

LOCATION

Chicago, IL

COMPLETION

2024

DESIGN & CONSTRUCTION TEAM

Farr Associates: Architect of Record
Walsh Construction: General Contractor
dbHMS: MEP Engineer
CEA&A: Structural Engineer
Klein & Hoffman: Building Forensics
Terra Engineering: Civil Engineer
site design group, ltd.: Landscape Architecture
Shen Milsom & Wilke: Acoustics
Jenkins & Huntington, Inc.: Transportation
Jenson Hughes: Code Consultant
MacRostie Historic Advisors: Consultant
Wiss, Janey, Elstner Associates: Conservator
RDH: Building Envelope
ArchiTect: Architectural Specifications

KEY ARCHITECTURAL STAFF

Doug Farr, FAIA: Architect of Record
Mercedes Miley, AIA: Project Manager, 2020-2025
Alina Tompert, AIA: Project Manager, 2024
Matt McGrane, AIA: Project Manager, 2016-2020
Genesis Gadberry, AIA: Architectural Designer
Tucker Touchette, AIA: Architectural Designer

DOCUMENTATION

Chicago YMCA: Historic Images
Couch Fire Films: Front
Kai Brown Photography: pp. 3, 23
Ross Floyd Photography: pp. 12-13, 15, 18, 24, Back
Farr Associates: Renderings & Photography
Walsh Construction: Construction Photography

AWARDS

National Trust for Historic Preservation
Richard H. Driehaus Foundation National
Preservation Award, 2025

Landmarks Illinois

Richard H. Driehaus Foundation Legacy Award, 2024
Richard H. Driehaus Foundation Award for
Rehabilitation, 2024

AIA Chicago

Honor Award for Ambitious Rehabilitation, 2024

AIA Illinois

Excellence in Historic Preservation, 2024

Chicago Building Congress

Merit Award for Renovation & Adaptive Reuse Over
\$20 Million, 2024

Chicago Neighborhood Development Awards

Polk Bros. Foundation Affordable Rental Housing
Preservation Award, 2024

Chicago Low-Income Housing Trust Fund

Beacon of Hope Award, 2024

CERTIFICATIONS

LEED Gold
Living Building Challenge: Affordable Housing Pilot

Note: This is a living document and will be periodically updated! The following pages both summarize the Lawson House project & provide insight into major design decisions & lessons learned from the Architect's point-of-view.

HAVE A STORY TO SHARE ABOUT LAWSON HOUSE?

Get in touch! Email us at hello@farrside.com or call 312-408-1661 x 412



"This housing has been preserved in one of the most unaffordable neighborhoods in Chicago. It is a reminder of how affordable housing is needed everywhere and shows a model of how to develop it in amenity-rich and highly desirable areas."

-Jackie & Peter Holsten¹

Lawson House, Chicago's historic YMCA, occupies the northeast corner of Chicago and Dearborn in one of the city's wealthiest neighborhoods. Built in 1931 as the tallest structure in a then-changing part of town, the building became a "city in a block," with 583 sleeping rooms, two gymnasiums, an indoor pool, cafeteria, barber shop, and many period-themed amenities.

The project's 28-month transformative rehabilitation provides dignified living conditions in 409 low-income single-room occupancy (SRO) units, approximately 1/3 of Chicago's new 2024 online units. The project's modernization marks the only complete renovation of units since the building's opening ninety years prior.

Designed for LEED Gold Certification, the biggest impact will be on the owner's utility bills: both water and electric bills are designed to a 37% reduction in usage. Considering the high-intensity usage of SROs, that difference saves ~\$215,000 per year. We look forward to following up with management 1-, 3-, and 5-years post-occupancy to evaluate their utility bills for actual savings.

This monumental historic renovation received the largest single allocation of LIHTC (Low Income Housing Tax Credits) funding in Illinois history and receives housing vouchers from five sources.

¹Landmarks Illinois: Interview with Jackie & Peter Holsten <https://tinyurl.com/lawsonhouselandmarksinterview>

A CITY IN A BLOCK— IN 11 MONTHS!

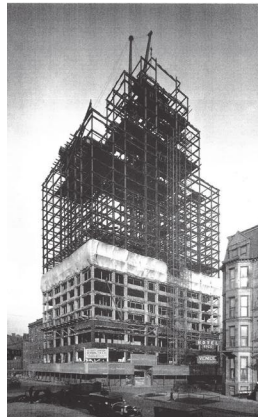
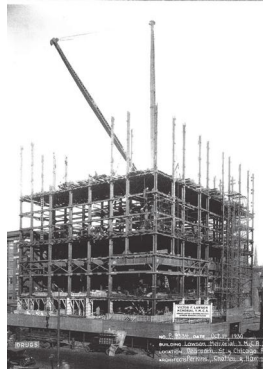

September 1930

May 1931

Originally built in 11 months' time, the structure comprises ~400 timber piles, a steel frame, concrete and clay tile fireproofing, and a hung terra cotta and brick façade.

Original Architect Perkins, Chatten & Hammond designed Lawson House to be a "city in a block", complete with athletic facilities and a suite of period-themed lounge spaces for residents to take a "grand tour" of architectural styles.

Although lovingly cared for by an on-site building engineer for 45 years, the building was severely out of date, the units lacked residential cooking facilities, and there was no access to amenities.



2020



A 28-MONTH RENOVATION

The building was stripped to its structural frame and exterior walls and a total façade restoration included new windows; all-new interiors and finishes with fully restored historic spaces; new systems included life safety, MEP, and telecommunications.

Holsten Human Capital Development (HHCD) temporarily relocated over 300 residents for the 2 1/2 year construction period. Former Lawson House residents received first dibs on the finished units and began moving back in phases starting December 1, 2024.



Updated mechanical systems in the boiler room.

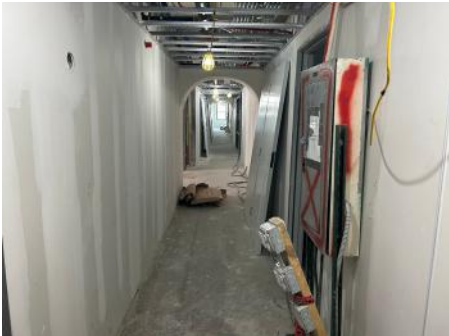

ALWAYS A CIVIL SERVANT

The Victor F. Lawson House, opened in 1931, was the main administrative headquarters for the YMCA of Metropolitan Chicago. Constructed as a large urban facility, it is a high-rise structure of twenty-four stories designed by Perkins, Chatten & Hammond in the stepped-back vertical Art Deco style of the 1930s. It is located at the northeast corner of West Chicago Avenue and Dearborn Street in a commercial area of Chicago's Near North Side, about five blocks north of the Chicago River and the Loop.

The building dominates its corner lot, stretching for 150' along Chicago Avenue and 104' along Dearborn Street, to the property line. The plan of the Lawson YMCA is a rectangle, which sets back to a U shape from the 5th to the 18th floor where it steps back further to the tower. The main entrance faces south, with both south and west elevations treated as primary façades.

In addition to the tower, the building's verticality is emphasized by the use of projecting piers, recessed spandrels and series setbacks. Clad in limestone up to the fourth floor, with golden-tan brick above, the building is trimmed in terra cotta and cast iron, and ornamented with chevrons, fluted pilasters, and flat relief stone panels.

Chicago was a focus of the country's transition from a primarily agrarian society to industrialized urban centers, which resulted in its rapid growth post-1870s. This growth resulted in poor, overcrowded housing and unsavory social conditions for the young men who were flocking into Chicago. Young immigrants from western and southern Europe

who poured into the city were often separated from their families and had little in their pockets. As a result, social crusaders looked for ways to help the immigrants and, in turn, the city. The YMCA became the primary organization to provide safe, clean lodgings within a religious and social context, supplying these services and helping young men, and eventually women, to culturally assimilate, learn English, find jobs, and maintain a moral compass.

The 1920s were a period of great expansion for the YMCA, as it charted its course for the twentieth century. Lawson YMCA was constructed in 1931 at the height of the Great Depression by many highly skilled craftsmen and artisans. It was made possible by a bequest from prominent civic leader Victor F. Lawson, publisher of the Chicago Daily News, which ultimately became the Associated Press. By the time the building was completed in 1931, the YMCA had become less exclusive in terms of religion and ethnic backgrounds, and the organization was renamed the YMCA of Metropolitan Chicago, bringing together its numerous branches, offices, hotel, and educational facilities.

In the 1930s, women were finally admitted as members and Lawson House was the center of the new "Family Programming" effort. During World War II, Lawson House focused on training young men for national defense and was a center of services and activity for soldiers and returning veterans. By the 1960s, there were 165,000 YMCA members in the city, in thirty-eight departments.

The Lawson YMCA represented all of the major movements of the Y during its period of significance.

The YMCA became the primary organization to provide safe, clean lodgings within a religious and social context, supplying these services and helping young men, and eventually women, to culturally assimilate.

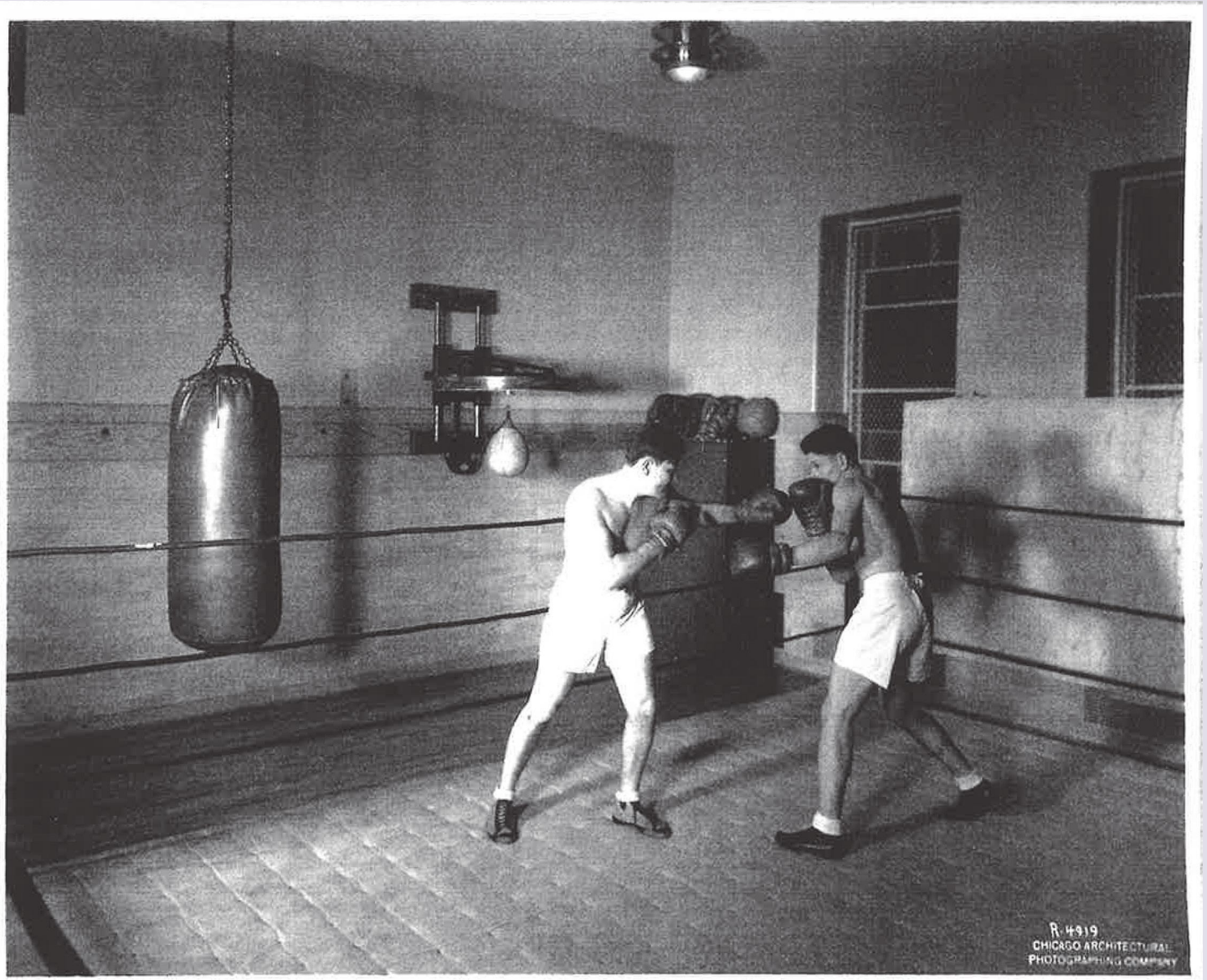

The building's unique spaces reflect the expansion of services from the YMCA to include more social, education, recreation, athletics, and vocational activities.



Dining Room



Log Cabin Period Room

LEARNING FROM THE RESIDENTS

Janice



"The building should be a SMOKE FREE ENVIRONMENT. I'm constantly spraying the hallway [with air freshener] to combat smoke from others down the hall."

Rob



"There aren't many healthy options, and market day food is hard to prepare with just a microwave. HEALTHY VENDING MACHINES in the Community Room would be one idea, with cheeses and yogurt, things like that."



The Design Team ran an integrated design process with interviews from all stakeholders including maintenance staff, social workers, residents, historic advisors, and neighborhood groups. Their experiences living in and around Lawson House contributed to major design moves, and final programming.

Left: Design Team members speaking with resident Nathan about his radiator.

SUPPORTING THE FULL PERSON

Allen



"If you do the renovation of the building but don't do any RENOVATION OF YOUR MIND, what good is it? The Holsten project should be a WHOLE PROJECT working with THE WHOLE MAN."

Nathan



"The radiator pipes let off a lot of HEAT... it really gets UNBEARABLE, but it's not something we can control."



Wrap-around supportive services are provided on-site by Holsten Human Capital Development and Renaissance Social Services.

Rental subsidies ensure affordability for low-income residents and are administered by Chicago Housing Authority, HUD, the VA, Renaissance Social Services, and Chicago Low Income Housing Trust Fund on 406 residential units.

Left: Grand reopening and move-in day for Residents!

DESIGN & DOCUMENTATION

BIDDING & PERMITTING CONSTRUCTION

CLOSEOUT



2009 Holsten Development considers purchasing the Lawson House. Competitive design options selected the design team.

2015 Design begins!

2017 Lawson House fails to secure funding from the City of Chicago and the project stalls. The project was at 50% Construction Documents at the time of the pause.

2019 The project secures all funding (!) and documentation continues. The development team value engineers ~\$3M, removing an elevator, changing the mechanical system, and redesigning the lower four floors.

2020 The project opens to bid at the beginning of the COVID-19 Pandemic.

2021 The Notice to Proceed arrives on December 2.

2023 Lawson House opens for the first wave of residents! Four additional turnovers would occur between December and April 2024.

2024 In April, the development team celebrates substantial completion for the full building.

2025 Closeout finalizes with LEED certification, right as post-occupancy research and documentation begins.



Mapping restroom amenities during an Integrated Design Workshop, 2015



Weekly Meeting with the Ownership, Construction, and Design Teams, 2022



Raising the final beam at the Lawson House Topping Out Celebration, 2023

PROVIDING DIGNITY THROUGH A TRANSFORMATIVE RESTORATION



Perkins, Chatten & Hammond was a prolific Chicago firm whose work represented a clear transition in both form and style from block buildings with classical ornament to the tall verticality of the Lawson YMCA.

In 1927, prominent Chicago School architect Dwight Perkins joined Melvin C. Chatten and C. Herrick Hammond of the firm Chatten & Hammond to form Perkins, Chatten & Hammond. During their years together (1927-1933) this experienced team of architects continued to design Chicago public

schools, and in 1928 designed two significant YMCA buildings: Duncan Hall of the West Side YMCA and the vast Lake View YMCA.

By 1929, they were able to transition to modernism and completed the design of two notable modern structures with Art Deco features: the Northwest Tower in Wicker Park and the Jones Armory on Chicago's south side, before designing the Lawson YMCA. It remains one of a handful of Art Deco towers in the city, and is the only one that was not designed for all or mostly commercial purposes.

HISTORIC BARBERSHOP TURNED LAUNDRY ROOM



Clad in vitrolite, a reflective black glass tile, the former Barber Shop houses the hygienic function of laundry while allowing people to congregate.

2024



1932



2015

SALVAGED & REIMAGINED EVENT HALL

The project infilled the pool for safety reasons, but the design allows for a complete reversal of the process to bring the pool back at any time.

2024



1932



2015



1932

The Chapel suffered from three water events during construction that dissolved many of the delicate, painted panels.

Opposite: Local artisans carefully painted 22 historic ceiling panels and faded wood trim details to make the original design pop!



LAWSON HOUSE: CASE STUDY

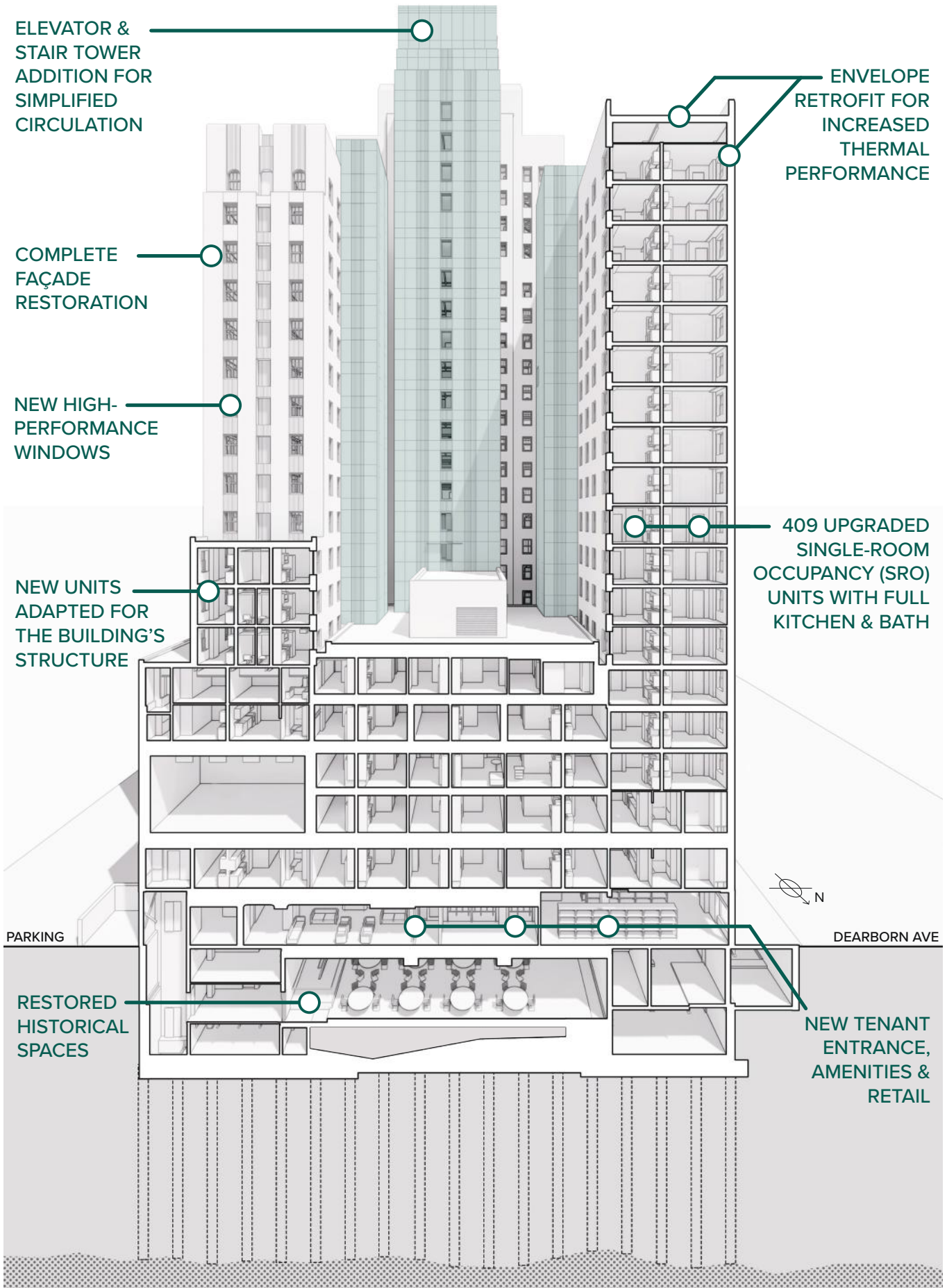

A photograph of a grand, curved staircase with a decorative wrought-iron railing and a wooden door in the background. The staircase is made of light-colored stone or concrete steps. The railing is ornate, featuring a repeating pattern of stylized, elongated oval shapes. The background shows a wall of light-colored stone or brick, a wooden door with two small windows, and an elevator door. The overall atmosphere is one of classic architectural elegance.

EXPERIENCE IS THE BEST TEACHER

Design Moves & Lessons Learned



MOVE #1: HOTEL-LIKE FEEL IN A NEW RESIDENTIAL LOBBY

The majestic entrance on Chicago Avenue only allowed 25' of runway to welcome residents and visitors. Residents interacted with 24/7 security personnel behind a Plexiglas surround, and the lack of visibility to other community rooms led them to be often locked.

The design moves the residential entrance to the quieter street, Dearborn Ave, and enlarges the vestibule for adequate accessibility and maintenance needs. The hotel-like lobby removes the

Plexiglas security desk, emphasizes natural light and materials, and adds richness with deep, bold colors. The octagonal elements mimic historic Art Deco motifs.

The ground floor accommodates a large seating area where residents can greet guests, and staff can casually perform wellness checks on residents. A new mail and package room serves both management and resident needs with more than half of the mailboxes at an accessible level.

SIGHT LINES FOR SAFETY

The reoriented floor plan places all ground floor spaces with a line of site from management or security personnel, providing safety without compromising use.



FIRST FLOOR

- RESIDENT SUPPORT
- MANAGEMENT OFFICE
- NEW CIRCULATION
- EXISTING CIRCULATION
- SUPPORT & MECHANICAL
- RETAIL



2020

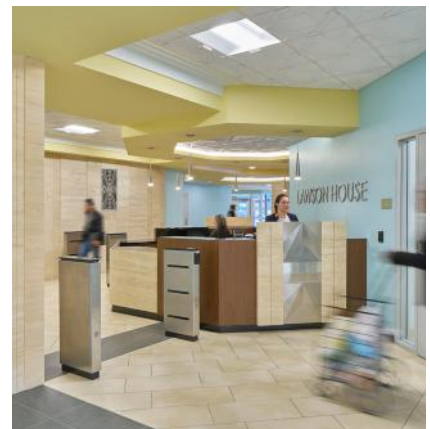

2024



MOVE #2: ADDRESSING LIFE SAFETY

The building included metal fire escapes on the North façade and small, passenger elevators that did not reach all residential floors. The only way to access the eastern 19th floor roof was to hop out of a window or take a metal catwalk that spanned between the two building masses. Just ask the design team who got stuck out on one of the fire escapes how fun it would be to egress 500 people down to the ground!

The rehabilitation added three additions to the exterior: two enclosed egress stairs and one freight/passenger elevator that reaches all units and amenity spaces.

All additions met State Historic Preservation Office (SHPO) and National Park Service (NPS) scrutiny for materials and colors, opting for a two-tone and two-texture Art Deco inspired design that compliments the original architecture and breaks down the massive 18-story façades. The original design included windows on every floor of the stair towers, but these were ultimately removed during value engineering.

Above: To save time, the construction team built the stair towers in three-floor sections and then lifted the pieces into place with a derrick crane on Floor 19.

THREE NEW ADDITIONS TO THE BUILDING— ALL FOR IMPROVED CIRCULATION

The new stair towers run all the way to the ground, avoiding transfer through hallways.

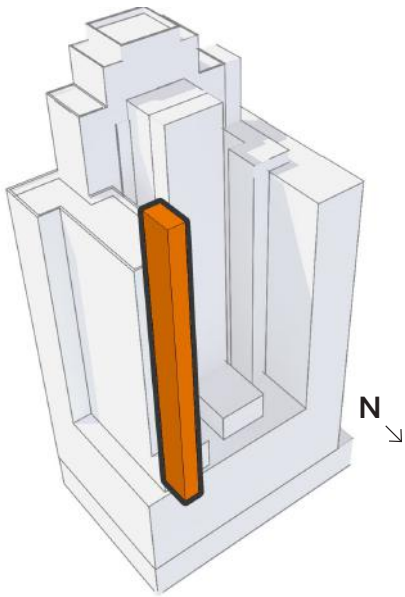

East Egress Stair

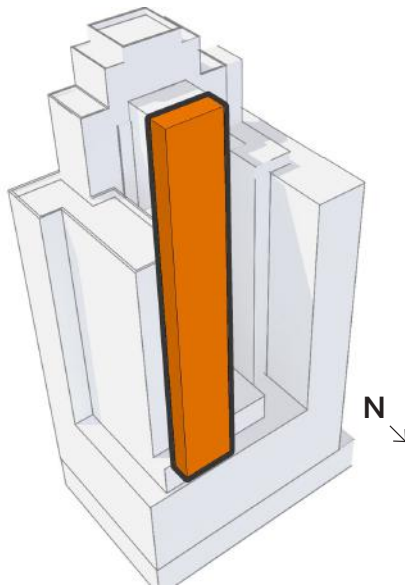

New Passenger + Freight

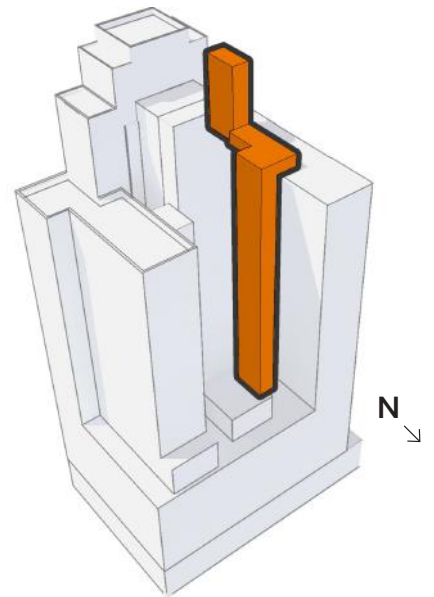

West Egress Stair



2015



2022

LAWSON HOUSE: CASE STUDY

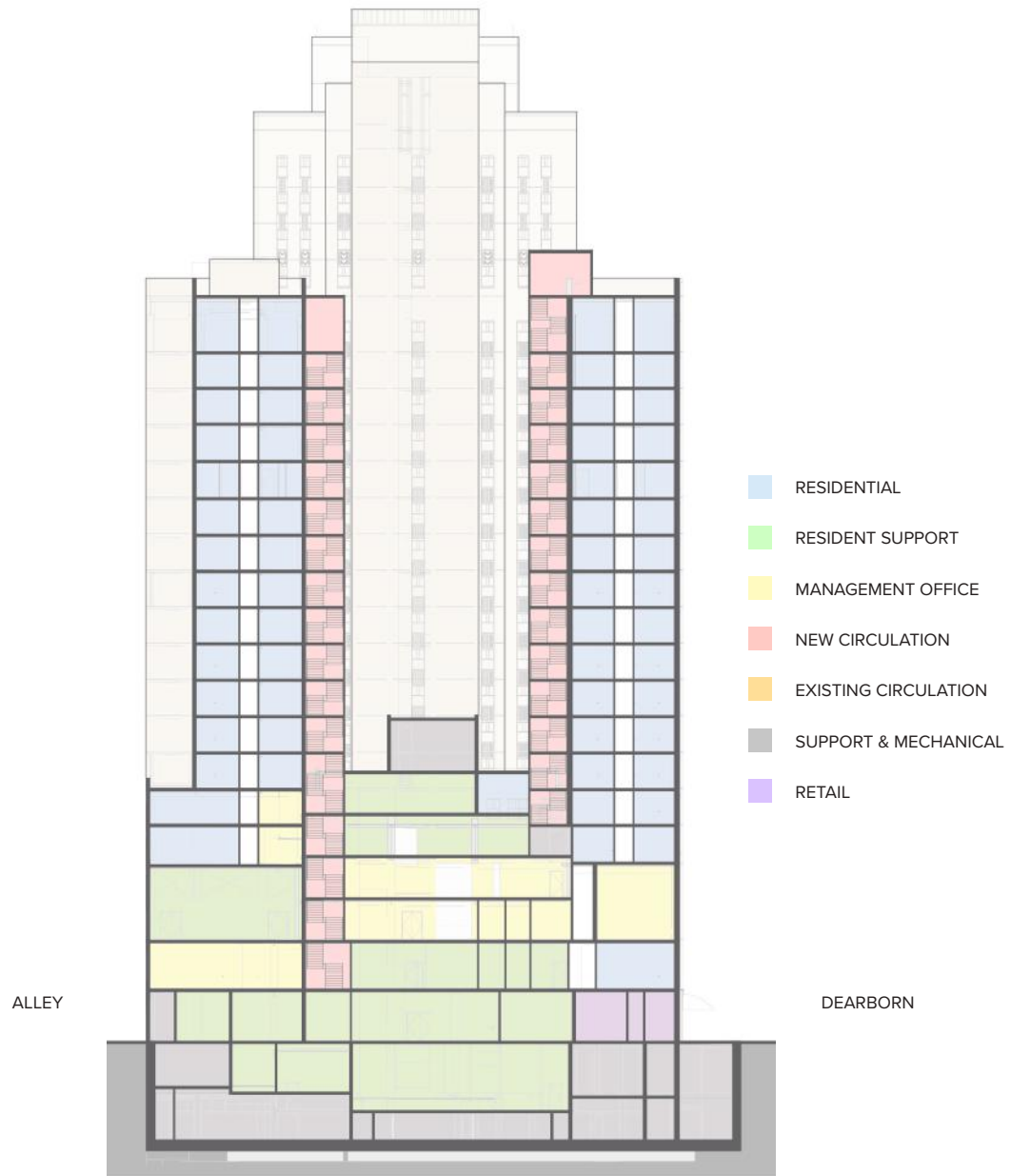

Egress stairs operate in the same vertical tower to comply with modern fire codes and no longer require egressing residents to leave one ending stair tower in search for the next way down.

In an emergency, the new elevator can accommodate a stretcher. Prior to this, firemen chair-carried an injured person down the stairs.



Details of the Historic Central Stair and construction in-progress.



MOVE #3: DIGNIFIED LIVING IN UPGRADED FACILITIES



Built to luxurious standards for hotel rooms in the Great Depression era, the rooms had declined in the last 90 years due to indoor smoking and wear-and-tear.

The original 583 sleeping rooms did not accommodate any cooking functions and most residents shared communal bathrooms down the hall. Because of this, the building predominately served men and needed to sex-segregate floors, limiting options for women residents.

Left: Kitchens are standardized, meant to be plug-and-play elements in an otherwise irregular floor plan.

STANDARDIZED, YET FLEXIBLE UNITS

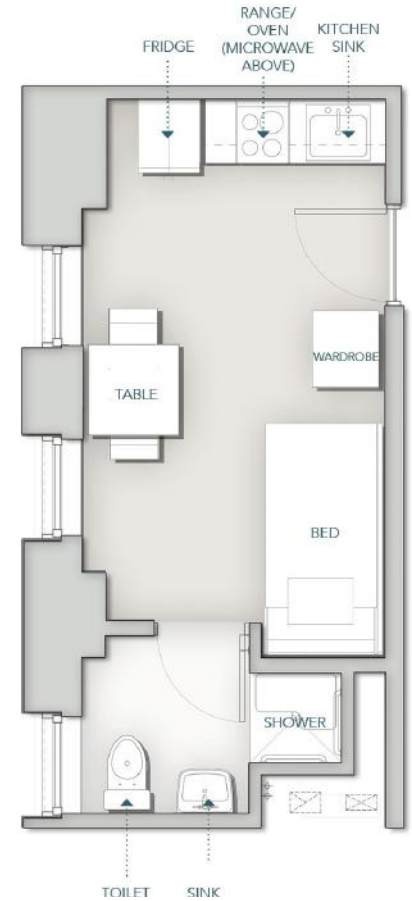

Today, all units include:

- Furnishings
- Universally-designed kitchens
- Private bathrooms
- Individual temperature controls

Required to comply with six accessibility codes and design standards, the design team decided to simplify and provided only two kitchen layouts: a standard and accessible version. This allowed the units, where nearly all are unique layouts, to be flexible, while standardizing key components.



1932



2020

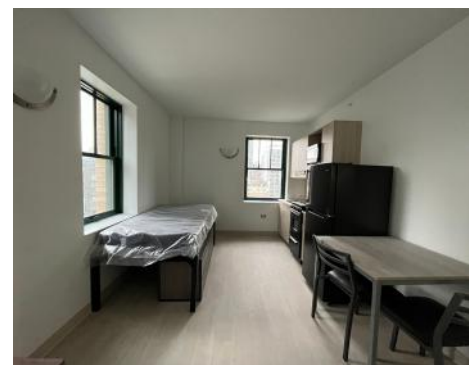

2023

ANALYSIS OF ORIGINAL UNITS

Original unit analysis shows sizes varied, but generally fell between 100-120 SF. Only some units had access to a semi-private bathroom.

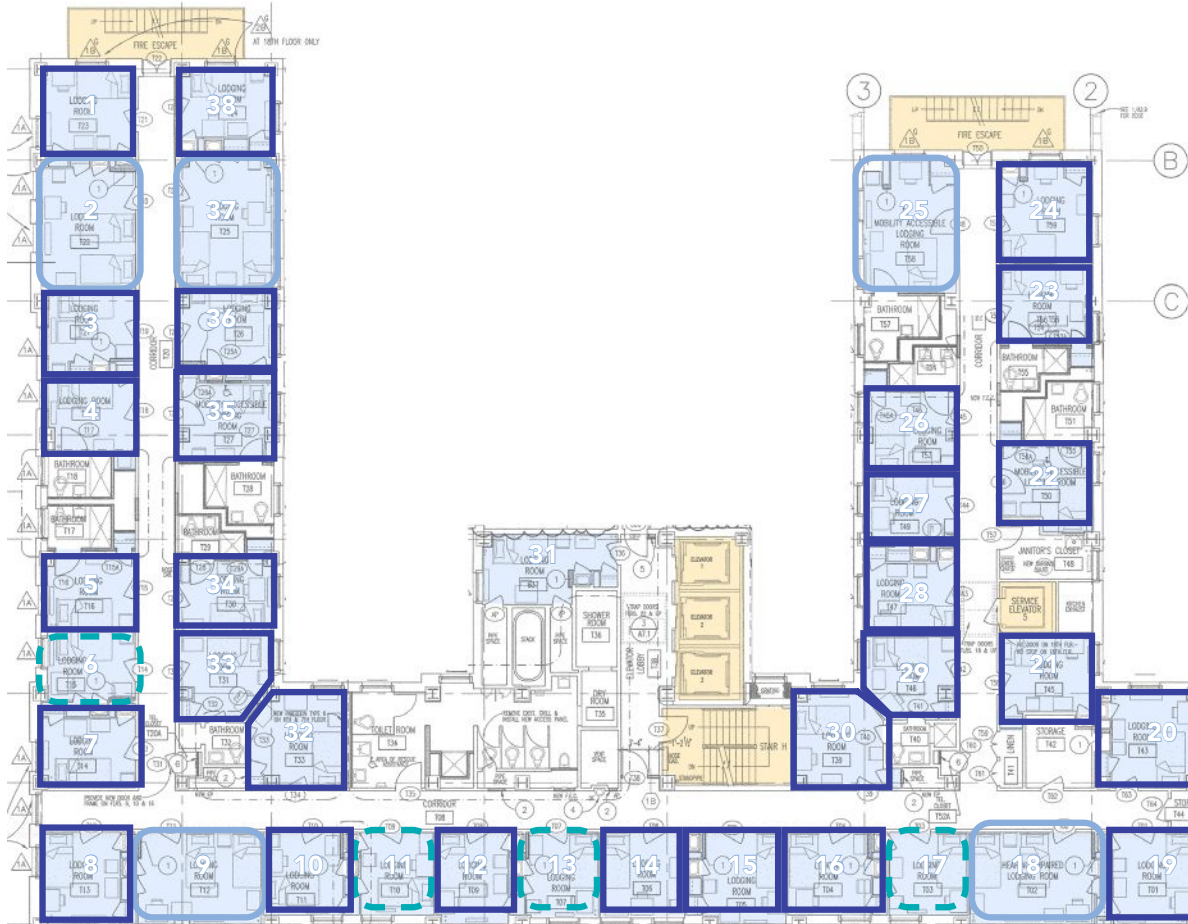

- RESIDENTIAL UNIT
- UNITS UNDER 100 SF (4)
- UNITS OVER 150 SF (5)
- UNITS BETWEEN 100-120 SF (29)

RECONFIGURING THE UNITS

The renovation reconfigures floors to transition from 38 units/floor to 24 units/floor. Each unit received private cooking and bathing facilities.

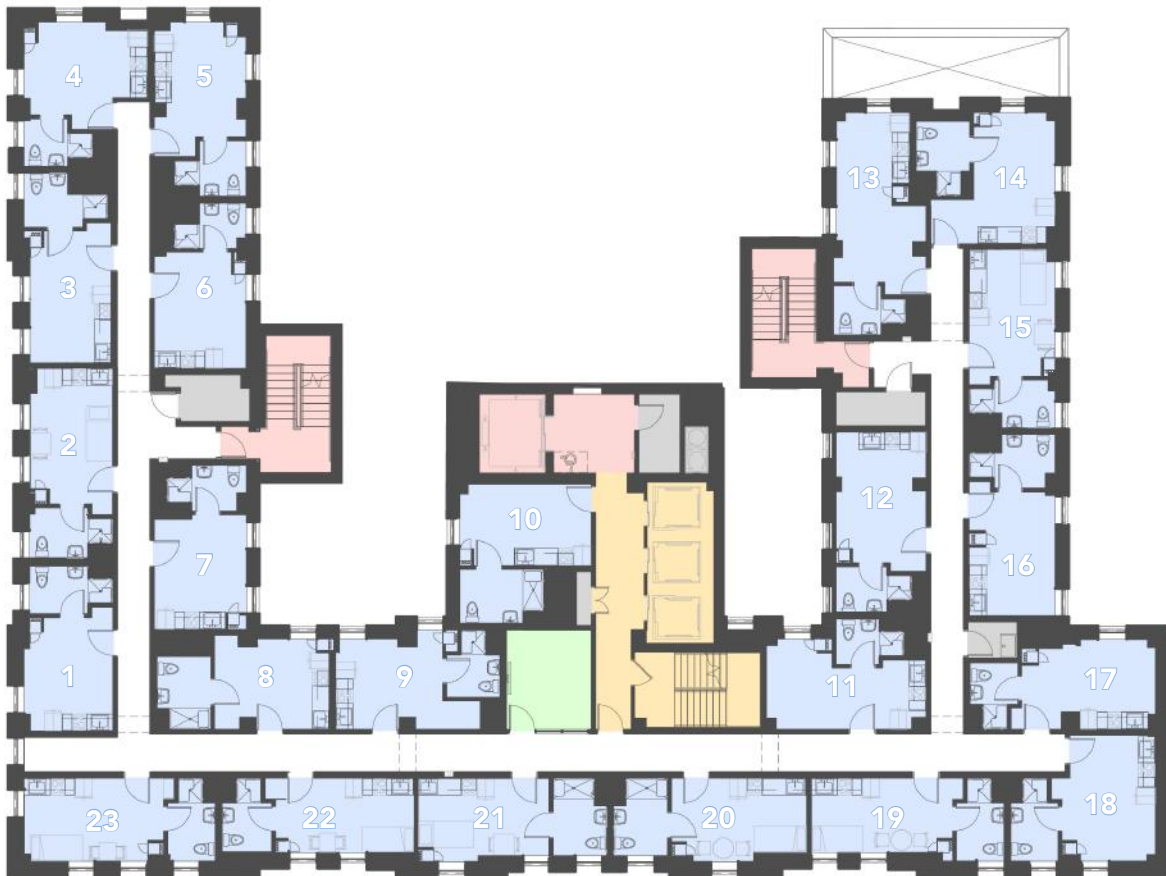

- RESIDENTIAL UNIT
- RESIDENT SUPPORT
- NEW CIRCULATION
- EXISTING CIRCULATION
- SUPPORT & MECHANICAL

LAWSON HOUSE: CASE STUDY

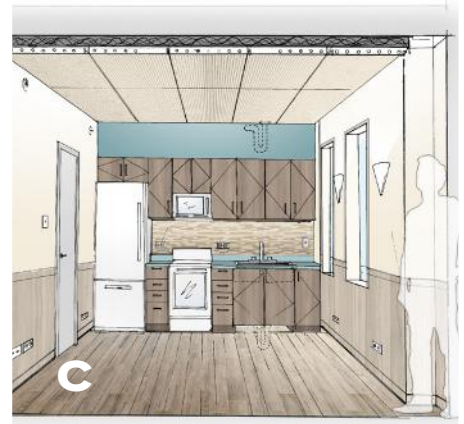
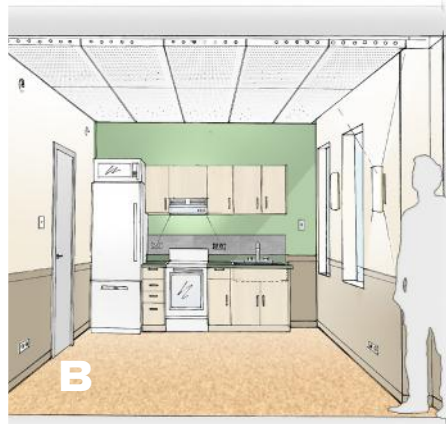

Three Schematic Design options demonstrate basic to elaborate interior finishes.



Final installation shows something akin to Scheme B.

BEHIND THE CURTAIN WALL, PT. 1

The design team thoroughly outlined building systems impact on unit ceiling & floor space.

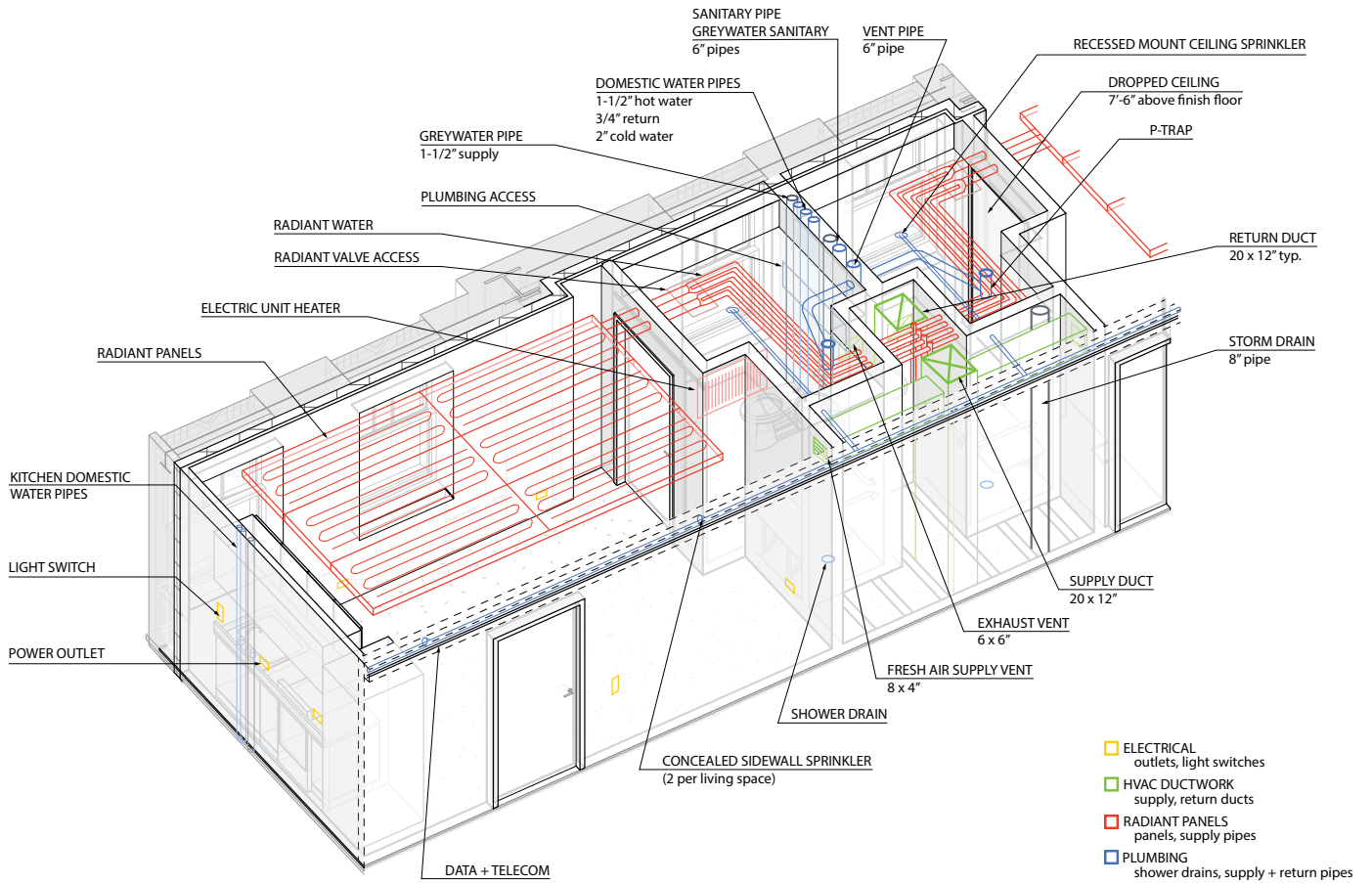

LESSON LEARNED #1: RADIANT HEATING PANELS

In 2017, the project underwent a back-of-the napkin value engineering process where the contractor, then Linn-Mathes, advised reworking the mechanical system from a radiant ceiling panel to fan coil units. Radiant ceiling panels took advantage of the very limited floor-to-floor heights, allowed for flexible installation based on room size, and without taking up the limited floor space. Expected energy savings with a radiant system were estimated at 51.2%. The expected cost savings from switching systems was \$1M (2017).

Ultimately, the design team questions if this cost savings estimate was ever realistic and it failed to account for other considerations, like additional pipe work needed in the ceiling space and each fan-coil unit requiring a 4"x12" cut out for three connection pipes. Despite Farr Associates' efforts during design and Walsh's further efforts in construction to reposition as many fan-coil units as possible to avoid the concrete structural joists in the slabs, approximately 80 joints were cut to the tune of nearly \$500,000.

Real Talk: This value engineering modification is the design team's single-most regretted decision of the project and we would have revisited further if time had allowed.



Radiant ceiling panels installed linearly show they are both a utility and architectural feature.

BEHIND THE CURTAIN WALL, PT. 2

Diagrams show how the design team proposed heating and cooling both the common spaces and units.

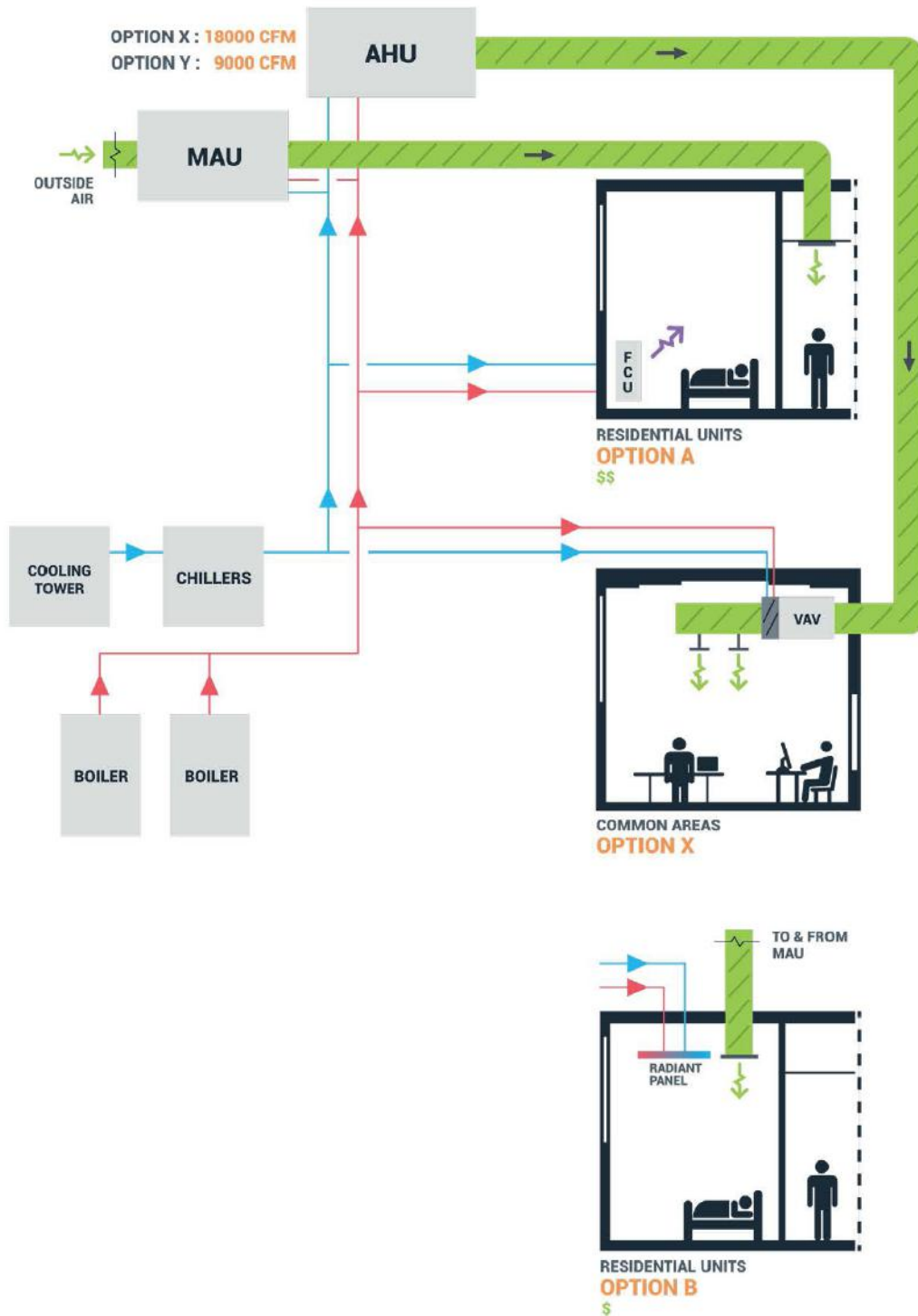

LESSON LEARNED #2: LAWSON HOUSE UNIVERSITY

For a project that spanned 15 years, it saw both remarkable turnover and also incredible continuity. Our design team, which started out as young designers, engineers, or managing principals, grew with Lawson House. We estimate Lawson House contributed substantially to the experience of at least ten now-licensed architects and probably triple the number of engineers.

Lawson House trained developers, maintenance staff, trade apprentices, new superintendents and foremen, design staff, served as a pilot program or case study for City and State initiatives, updated green design rating systems, and historic preservation standards.

Over the course of those 15 years:

- The original contractor (Linn-Mathes) shut its doors and we onboarded a new one (Walsh Construction) during the final bidding process.
- USGBC launched not one, but two, new rating systems that the design team needed to evaluate. Lawson is certified LEED Gold under v3, 2009.
- Four of six of the core design team project managers were elevated to managing principals or owners of their respective firms. All kept Lawson House in their portfolios and managed the project until the end.
- In the three years of construction, nine project team members went on maternity or paternity leave from either the architecture or construction side.

That's a lot going on!



During one of many on-site trainings, representatives demonstrate fall protection technology.



Mercedes Miley punchlisting with now-licensed architect, Genesis Gadberry.

We estimate Lawson House contributed substantially to the experience of at least 10 now-licensed architects!



Farr Associates supplied four project managers over the 15 years, but kept the same principal-in-charge, Doug Farr, for the duration. Our design & engineering partners did the same.

Here's how we managed:

- **Communication Two-People Deep:** Project managers or principals copied a more junior design team member on the majority of all correspondence, allowing for the transfer of information naturally over time as people moved up or out.
- **Integrated Design Process:** Farr Associates' standard process brings all design professionals and key stakeholders to the table early in the design process. This frontloads decisions and requires the entire team to buy into design decisions. When things inevitably change, we know we all started out with the same baseline and can pivot accordingly.
- **Coordinated Family Leave:** Supervising Architect Mercedes Miley and Project Architect Alina Tompert had maternity leave one month apart during the final phases of construction (summer-fall, 2023). They worked with the client and contractor team to transfer information back-and-forth, front-loading decisions, submittals, and approvals as much as possible prior to Mercedes' leave. Alina had previously worked on Lawson House in 2015-2017 and had background knowledge of the project that another interim project manager would have lacked.

Here's where we could have done better:

- **Updated Drawing Sets:** The 2020 Issue for Bid drawing set was drawn for Linn-Mathes. They had been on our OAC team advising on constructibility since the beginning and we had drawn collaboratively with them. Because of this, the drawing set wasn't appropriate to hand over to a new contractor without updating. We perceived we were unable to make changes because the drawings were already in bidding and permitting. However, had we insisted upon a drawing review at the time, we believe this would have saved time and cost later by onboarding the contractor earlier.
- **Clearer Outlining of Real Standards:** Several reviewing bodies upgraded their design standards over the course of the project, including the City of Chicago which updated its entire building code. Our team could have more successfully documented and made clear on our drawings sets that we were grandfathered in under old code or rating standards.

Were there lapses in communications or things we simply couldn't find because so-and-so had left three years prior?

- Yes, but at least on the architecture team's side, the main players stayed in contact and fielded questions from leave or other jobs to ensure the ultimate success of the project.



Top Left: Mercedes Miley & Alina Tompert on-site. Above: Doug Farr, Mercedes Miley, Genesis Gadberry, and Alina Tompert at the Ribbon Cutting Celebration.

LESSON LEARNED #3: ADVANCED COORDINATION

Lawson House required an additional QA/QC process specific to building systems prior to release to the construction team. This largely came down to time as the team rushed to meet milestones that would then get delayed or halted completely by outside forces.

When we picked things back up months or years later, where even were we? We still would have been surprised by field conditions (see Lesson Learned #4), but Farr Associates now requires a third-party design review for projects of this size to catch things the design team is simply too close to see.



Detail of the Historic Lobby Ceiling.

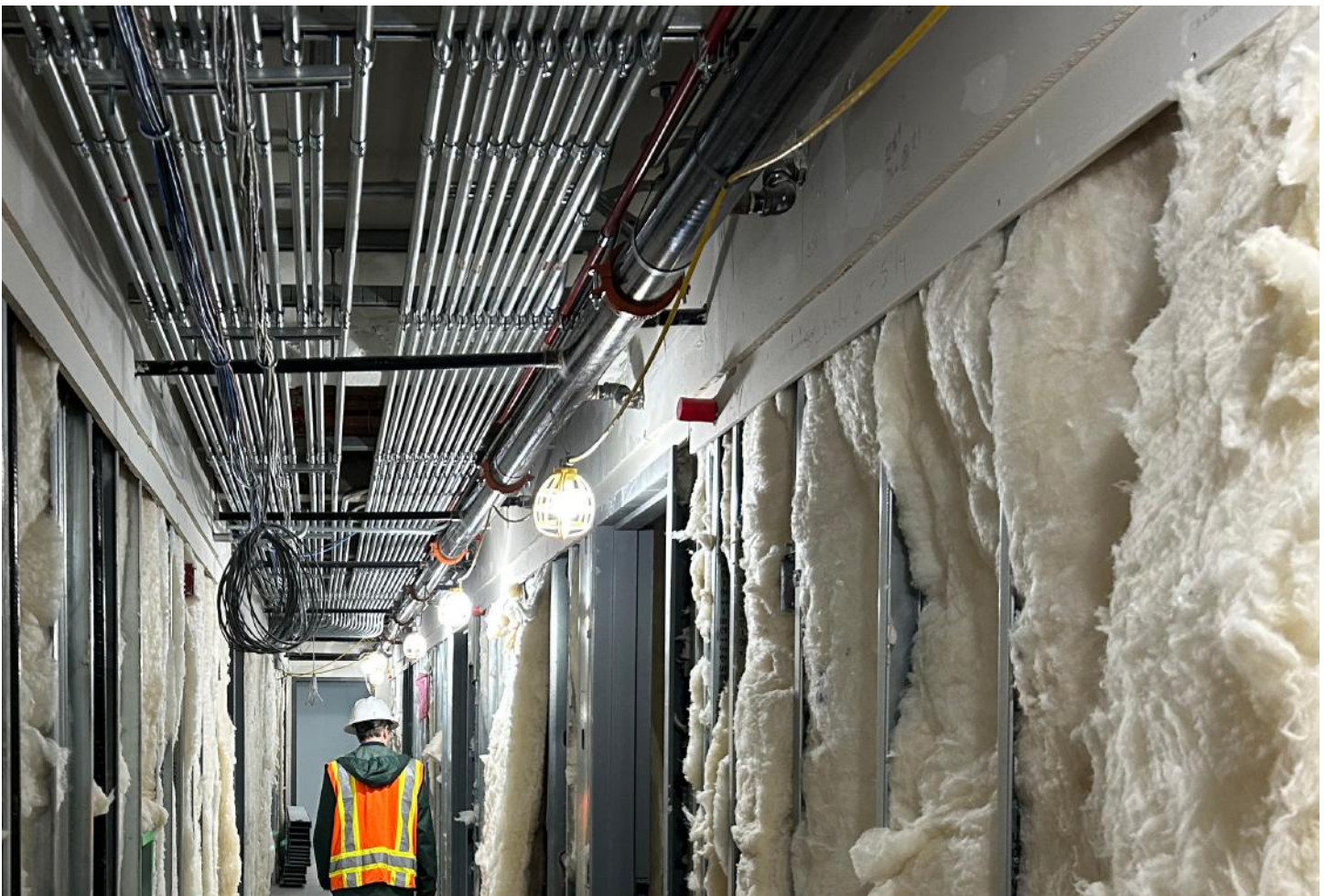

*Newly-installed building systems run in a 1'-2" cavity.
Dropped beams shrink the ceiling space even further in some locations.*

LESSON LEARNED #4: ADDITIONAL FIELD VERIFICATION



Klein & Hoffman verifying existing conditions of the façade.

Lawson House was occupied continuously during design and there were some spaces the design team had never seen prior to construction due to Owner restrictions. This severely limited our ability to document existing conditions and prevented exploratory demolition of known unknowns.

Even at Lawson House, which operates 24/7 (no weekend downtime for on-site supportive services), the design team might have been able to find creative ways to perform site documentation. In future projects, we'd insist on a period of down time where admission by outsiders is allowed. For example, we could have paired our visits with

LIHTC compliance required unit checks. This would have avoided an extra visitor to residential spaces while still allowing information gathering for our design team members. Knowing more information in design would have paid dividends in construction.

Additionally, all final drawings were constructed from either existing 1931 documentation or hand-field verification. That's what we had access to at the time. Nowadays, every other home on Redfin has a digital scan. This technology has now advanced into a commodity that we would absolutely use to document existing conditions on our next project of similar size.



Farr Associates Architecture & Urban Design
The Historic Monadnock Building
53 W Jackson Blvd, Suite 650, Chicago, IL 60604
☎ 312-408-1661 ✉ hello@farrside.com
🌐 farrside.com 📁 farrside.substack.com

Mercedes Miley, AIA
President
✉ mercedes@farrside.com
☎ 312-408-1661 x 208

Contact: Breanne Trammell, MFA
Director of Marketing
✉ breanne@farrside.com
☎ 312-408-1661 x 412

Just. WOMEN OWNED

We collaborate with clients and partners to create frameworks and systems that realize sustainable aspirations towards healthy, living futures.

Founded in 1990, Farr Associates is a Chicago-based full-service architecture and urban design firm at the forefront of decarbonization and high-performance buildings, with expertise in building envelopes, green technologies, and healthy spaces and materials.

We love old buildings and firmly believe the most sustainable building is the one that has already been built! We have over 30 years of experience working with existing buildings, including historic structures and National Landmarks.

Our team is well versed in the technical aspects of working with existing façades, whether they are historic or merely old, from moisture management to thermal performance, and from repairs to wholesale replacement. We manage large teams, complicated schedules, and track budgets to give the best value to the owner.

Do you have an old building, but one that isn't officially "historic?" We love those, too! Get in touch! We'll take a sensitive approach to the historic elements, and meet your needs for adapting the structure to a new use.

