



TECHNICAL DATA

GENERAL		T 204 H
Load capacity	lb	4,400
Load capacity at maximum height	lb	4,400
Maximum lift	ft	13.77
Maximum lift under maximum load	ft	13.77
Maximum reach	ft	8.43
Maximum load at maximum reach	lb	2,200
Unladen weight *	lb	9,260
Transmission	-	2-speed hydrostatic
ENGINE		
Make	-	KUBOTA
Model	-	V-2403
Power	hp	48.9
Torque	Nm@rpm	160@1,600
No. cylinders	-	4
Emissions	-	Stage IIIA - Tier 4i
Ambient noise	dB(A)	101
Consumption	gal/h	2.16
CO2	lb/h	46.3
DRIVING		
Maximum speed	mph	14.9
Gradeability under full load	%	50
Traction	-	4x4x4
Front tyres	-	10/75-15.3
Rear tyres	-	10/75-15.3
HYDRAULIC SYSTEM		
Flow rate	gal/min	14.7
Working pressure	psi	3,480
TANK CAPACITY		
Fuel	gal	17.2
Hydraulic	gal	18.5
BRAKES		
Service	-	Hydraulic - Disc
Parking	-	Mechanical

\* It may change due to optional equipment

## DIMENSIONS

AUSA carriage

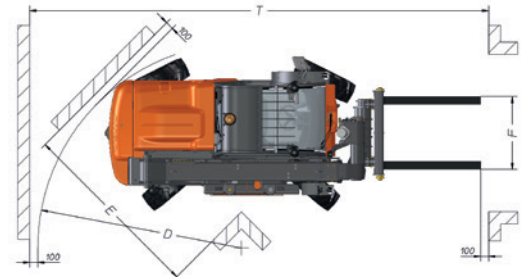
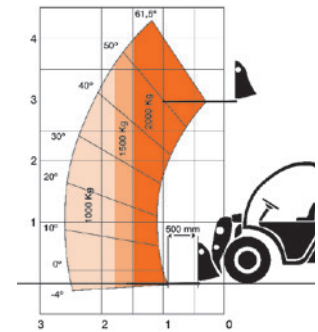
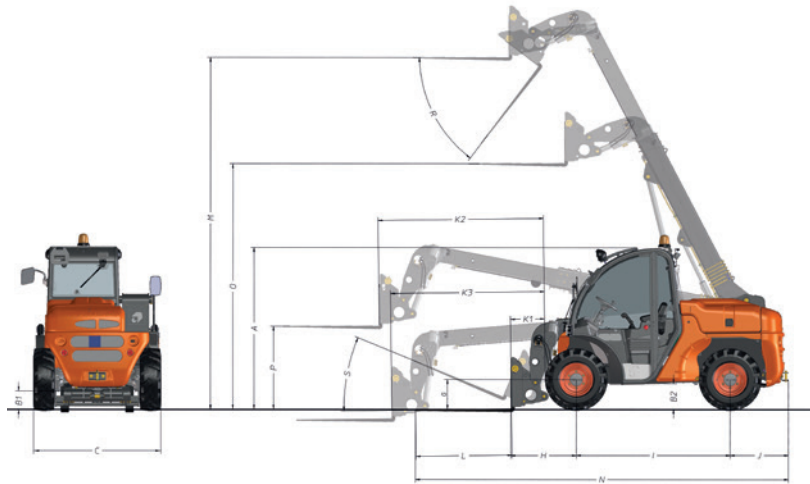

DIMENSIONS (in)	T 204 H
A	79.64
B1	9.09
B2	12.63
C	62.40
D	113.26
E	91.18
F	39.96
G	14.60
H	32.28
I	75.82
J	28.74
K1	16.85
K2	81.57
K3	75.78
L	47.24
M	173.26
N	183.77
O	120.94
P	40.90
R	52°
S	23°
T	224.80



[www.ausa.com](http://www.ausa.com)

Products are subject to modifications without prior notice. Images throughout the spec sheet may refer to non-standard machines or non-available configurations depending on models.

AUSA's logo and corporate identity are property of the Company, they cannot be used without authorization.

