

FitCampus 2

Elevate the fitness experience in your school with FitCampus 2 Outdoor Fitness Park. Designed to cater to the unique needs of students, this outdoor facility offers a comprehensive range of exercise equipment that promotes physical health and wellness. With FitCampus 2, students can enjoy invigorating workouts and develop healthy habits in a fun and inspiring environment.

Attributes

Product code	1-3-243
Certificate	EN 16630
Age group	14 + years
Designed for	Schools
Capacity	20 people
Fall height	2.1 m

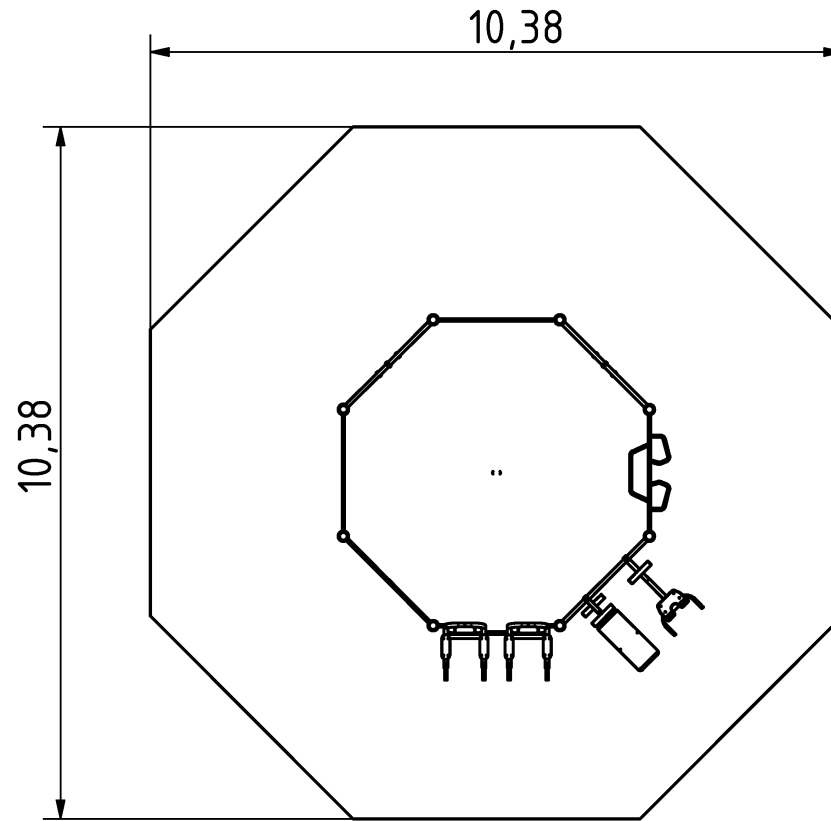

Technical specification

Anchoring option
 Net weight
 Material
 Anti-corrosion possibility
 Total Area
 Color options
 For more color options, discuss with your sales representative.

In-ground or surface
 1864 kg
 S235
 Galvanized or EPD
 89.3 m²



Warranty

Structure
 Steel
 Paint
 Plastic
 Rubber
 Moving parts
 Detailed information in the warranty document

25-15 years
 5-10 years
 2 years
 5-10 years
 1-3 years
 2 years