

# TEMPER

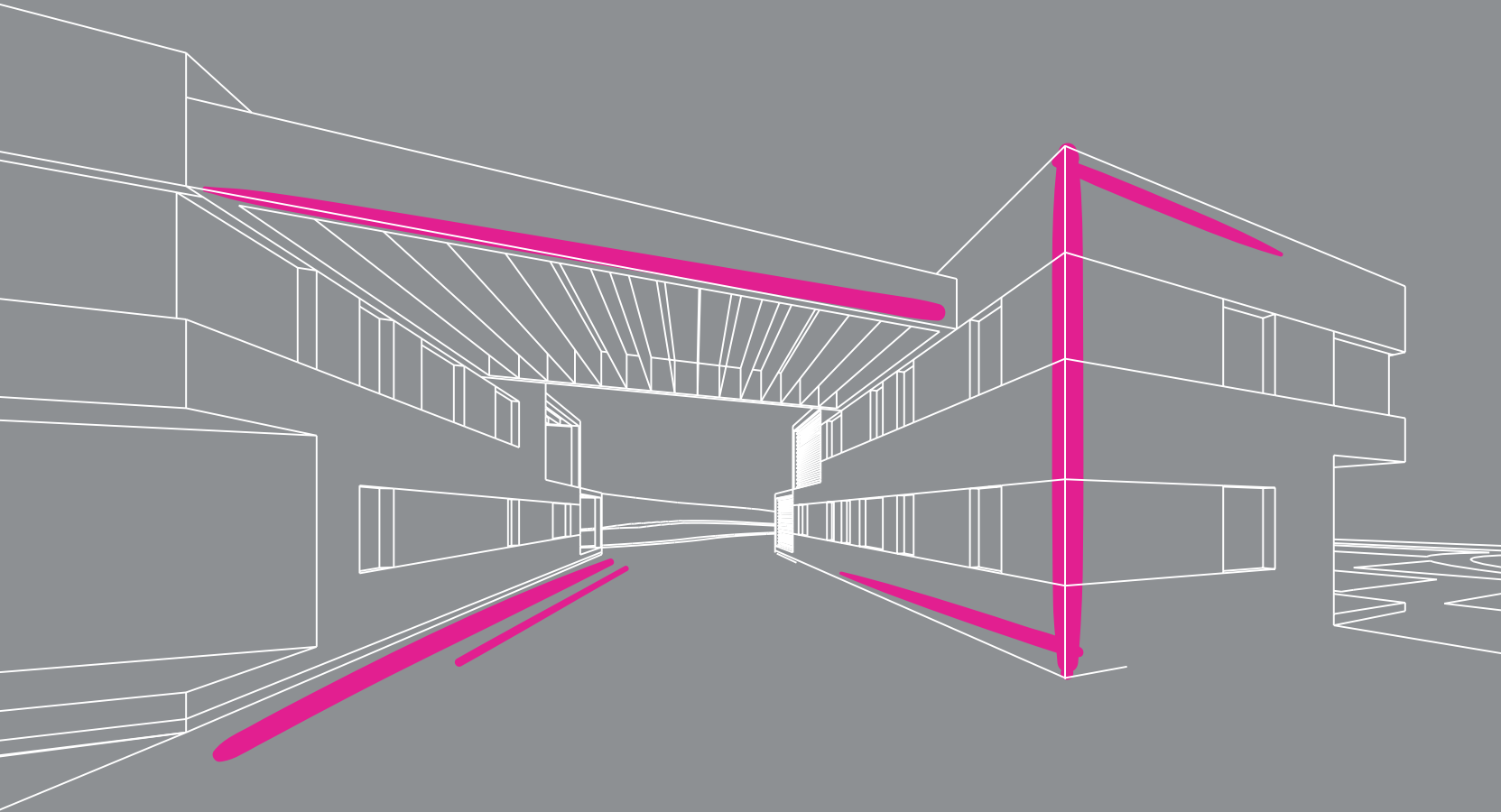

Design your life

# TEMPRARE

/tem·prà·re/

*verbo transitivo*

1. Sottoporre un metallo al trattamento di tempra per aumentarne la durezza e la resistenza meccanica
2. Fortificare il fisico, il carattere e lo spirito di una persona

## temper

/tem·pər/

*transitive verb*

1. To subject a metal to tempering treatment in order to increase its hardness and mechanical strength
2. To strengthen the body, character and spirit of a person

## tremper

/trɛ̃·pe/

*verbe transitif*

1. Pratiquer l'opération de trempe d'un métal pour en augmenter la dureté et la résistance mécanique
2. Fortifier le physique, le caractère et l'esprit d'une personne

## härten

/här|ten/

*Transitives Verb*

1. Ein Metall einem Härungsverfahren unterziehen, um seine Festigkeit und mechanische Widerstandsfähigkeit zu erhöhen
2. Den Körper, Charakter und Geist einer Person stärken

## закалять

/за·ка·лять/

*переходный глагол*

1. Подвергать металл процессу закалки для повышения его твердости и механической прочности
2. Укреплять тело, характер и дух человека

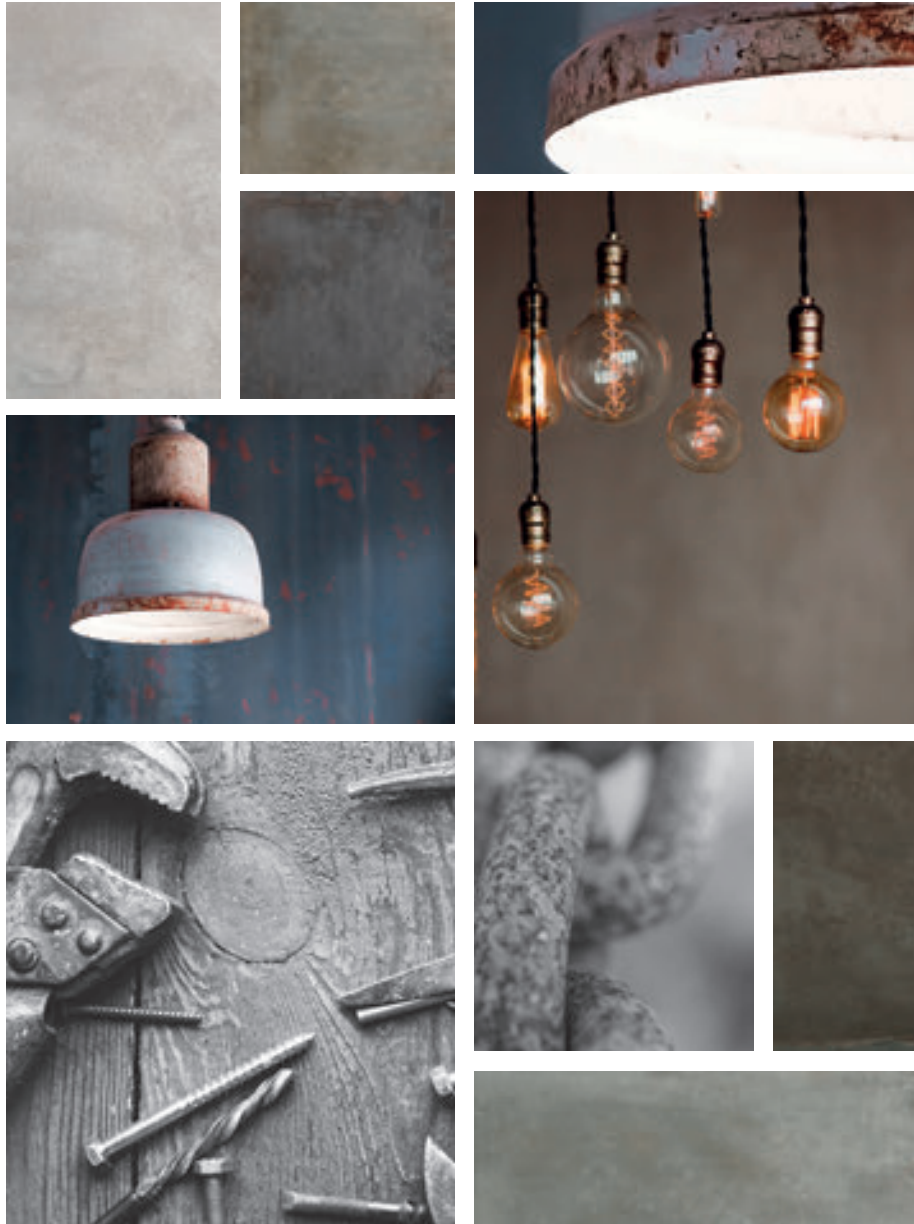

**TEM PER GOLDEN**





TEMPER GOLDEN  
50x100 . 20"x40" RETT

TEMPER GOLDEN  
50x100 . 20"x40" RETT





TEMPER GOLDEN  
50x100 . 20"x40" RETT

TEMPER GOLDEN  
50x100 . 20"x40" RETT







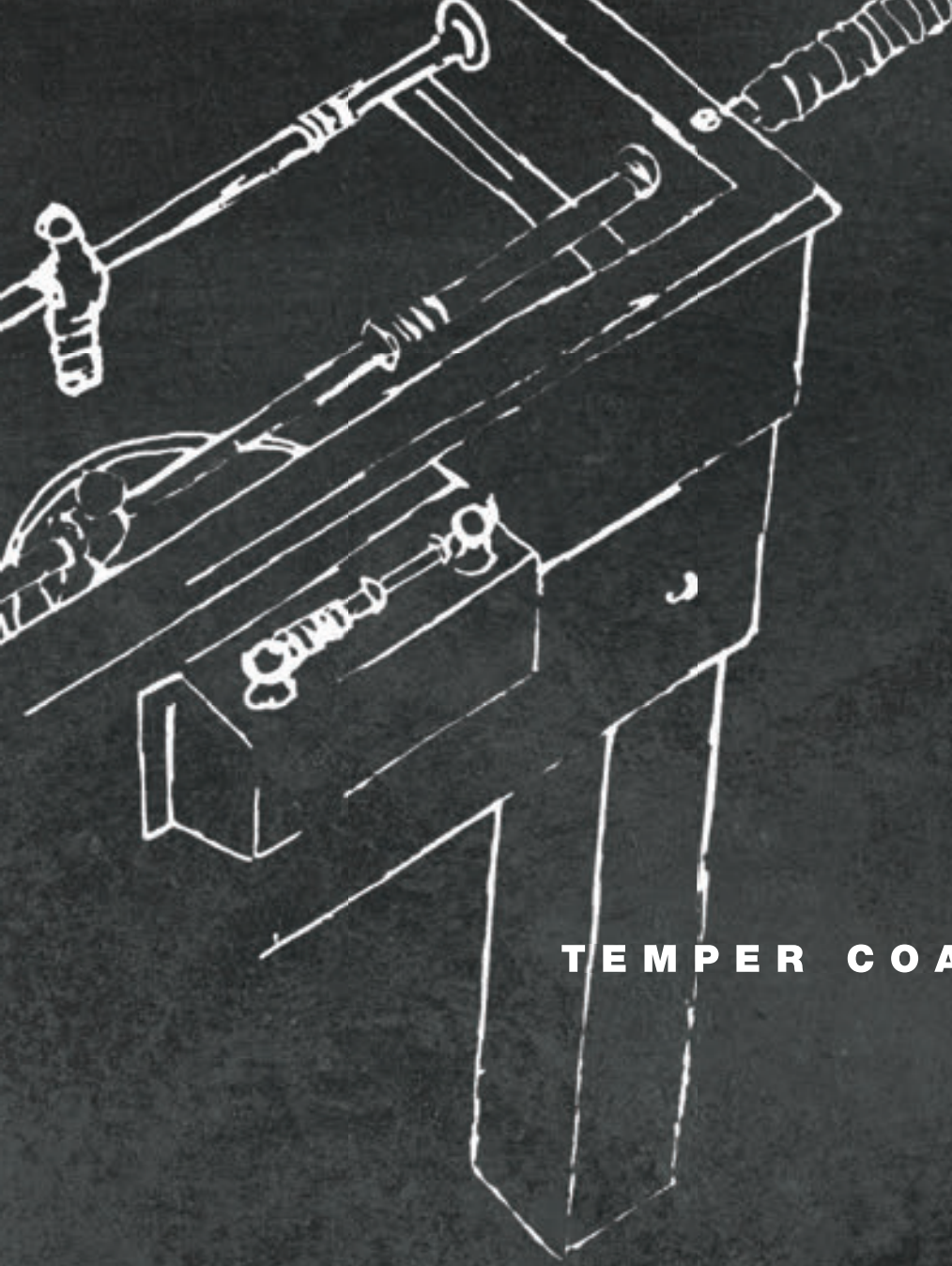

**TEMPER COAL**



TEMPER COAL  
100x100 . 40"x40" RETT

TEMPER COAL  
100x100 . 40"x40" RETT





TEMPER COAL  
100x100 . 40"x40" RETT

---

TEMPER COAL  
100x100 . 40"x40" RETT





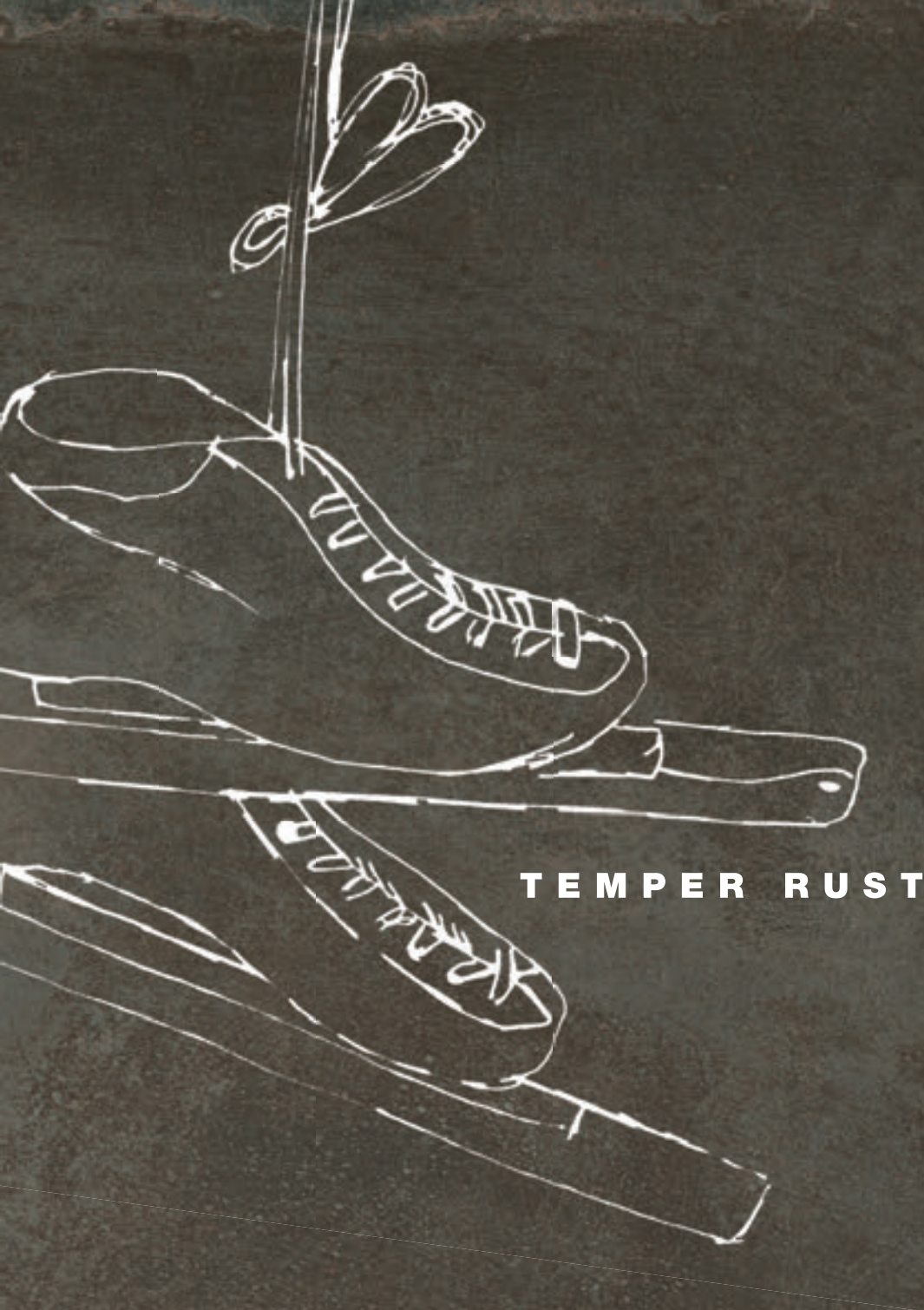

**TEMPER RUST**





TEMPER RUST  
60x120 . 24"x48" RETT  
30x120 . 12"x48" SCRATCH RETT

TEMPER RUST  
60x120 . 24"x48" RETT  
30x120 . 12"x48" SCRATCH RETT





TEMPER RUST  
60x120 . 24"x48" RETT  
30x120 . 12"x48" SCRATCH RETT

TEMPER RUST  
60x120 . 24"x48" RETT  
30x120 . 12"x48" SCRATCH RETT





TEMPER RUST  
60x120 . 24"x48" RETT  
30x120 . 12"x48" SCRATCH RETT





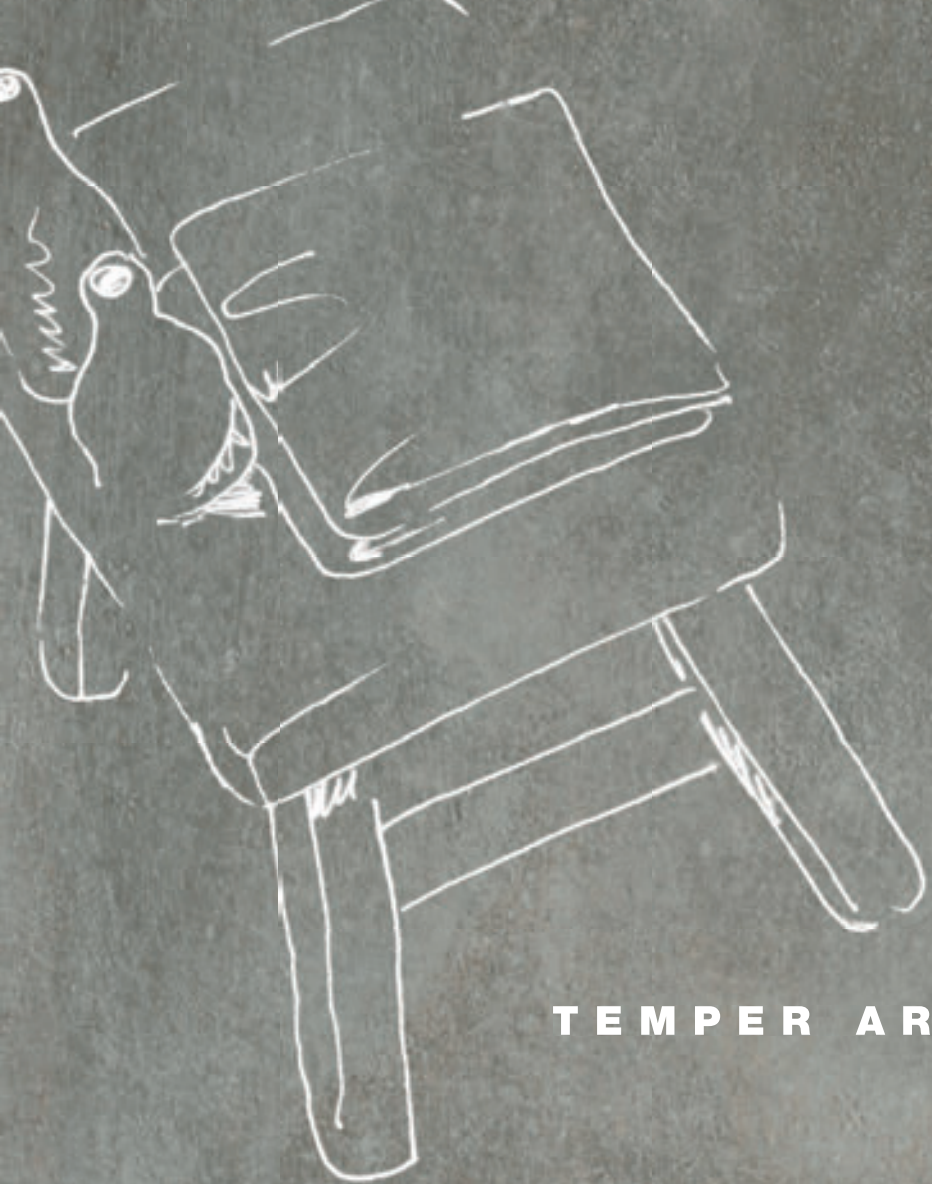

**TEM PER ARGENT**





TEMPER ARGENT  
100x100 . 40"x40" RETT  
Mosaico Bricks Mix 24x40 . 9 7/16"x16" RETT

---

TEMPER ARGENT

120x120 . 48"x48" RETT - 60x120 . 24"x48" RETT

Bamboo Silver (base Argent) comp 2 pz 120x120 . 48"x48" RETT





TEMPER ARGENT  
120x120 . 48"x48" RETT  
Mosaico Bricks Mix 24x40 . 9 7/16"x16" RETT





TEMPER ARGENT  
80x180 . 32"x72" RETT  
Bamboo Silver (base Argent) comp 2 pz 120x120 . 48"x48" RETT





TEMPER ARGENT  
Mosaico Bricks Mix 24x40 . 9 7/16"x16" RETT

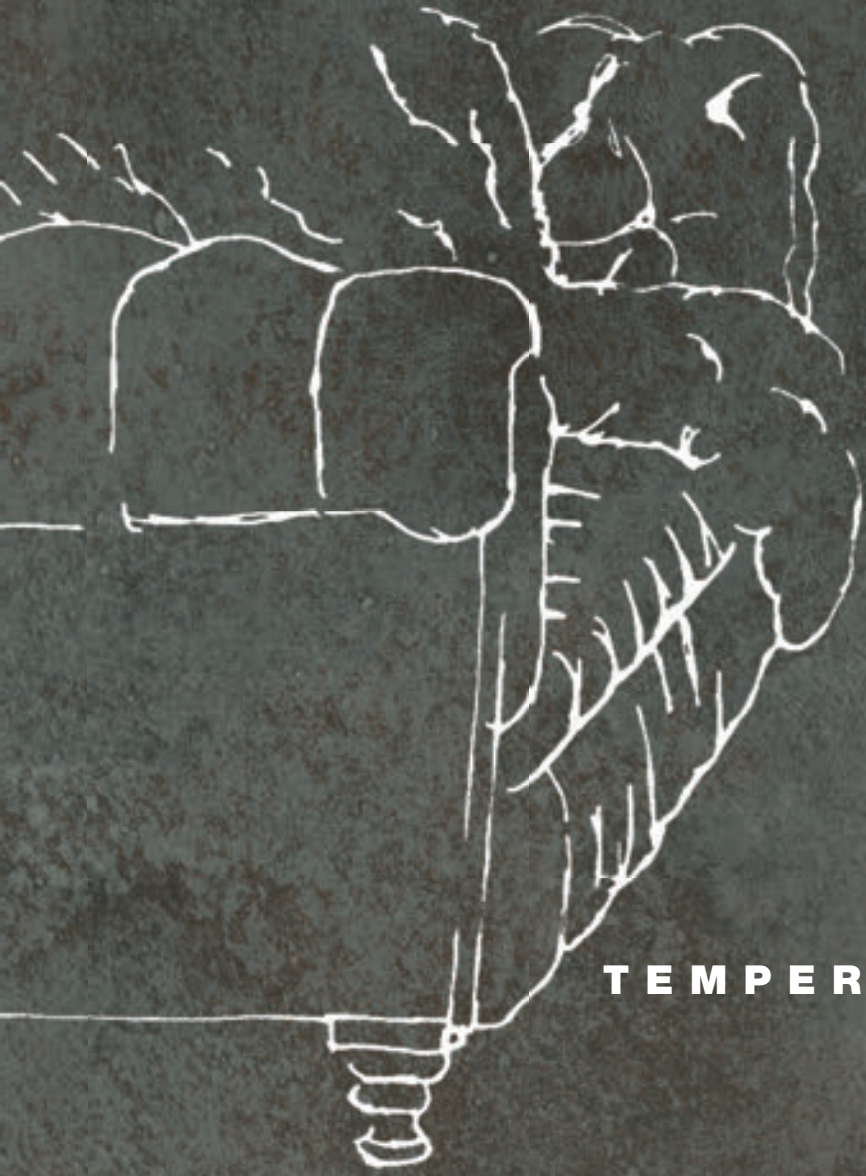

**TEMPE R I R O N**





TEMPER IRON  
80x180 . 32"x72" RETT

TEMPER IRON  
80x180 . 32"x72" RETT





TEMPER IRON  
80x180 . 32"x72" RETT

TEMPER IRON  
60x60 . 24"x24" RETT  
Inserto Weld Silver S/8 30x30 . 12"x12" RETT





TEMPER IRON  
100x100 . 40"x40" SCRATCH RETT

**TEMPE R FROST**





TEMPER FROST  
60x120 . 24"x48" **19MM** RETT R11  
pezzi speciali: **19MM** RETT R11

TEMPER FROST  
60x120 . 24"x48" 19MM RETT R11  
pezzi speciali 19MM RETT R11







TEMPER FROST  
60x120 . 24"x48" **19MM** RETT R11  
pezzi speciali **19MM** RETT R11

TEMPER FROST  
120x120 . 48"x48" RETT  
Mosaico Metallic 30x30 . 12"x12" RETT





TEMPER FROST  
60x120 . 24"x48" 19MM RETT R11





TEMPER FROST  
60x120 . 24"x48" 19MM RETT R11

# TEMPER

80x180 - 32"x72" . 120x120 - 48"x48" . 60x120 - 24"x48" . 30x120 - 12"x48" . 60x60 - 24"x24" . 30x60 - 12"x24" . 100x100 - 40"x40" . 50x100 - 20"x40"



80x180 . 32"x72" RETT

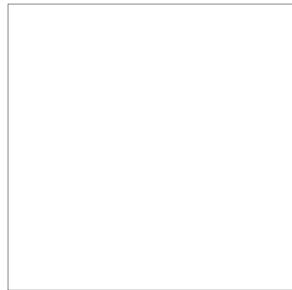

100x100 . 40"x40" RETT



50x100 . 20"x40" RETT

 **8,5 mm - 5/16"**  
 spessore  
 thickness  
 épaisseur  
 stärke  
 толщина

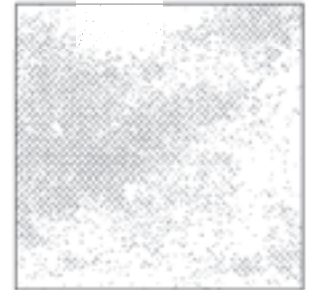

100x100 . 40"x40" SCRATCH RETT

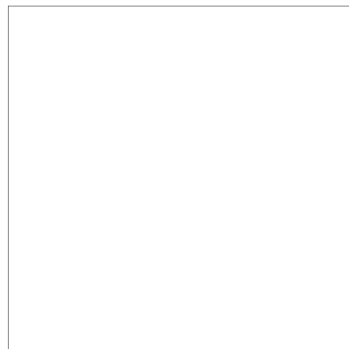

120x120 . 48"x48" RETT



60x120 . 24"x48" RETT



30x60 . 12"x24" RETT



60x60 . 24"x24" RETT

 **10 mm - 3/8"**  
 spessore  
 thickness  
 épaisseur  
 stärke  
 толщина



30x120 . 12"x48" SCRATCH RETT

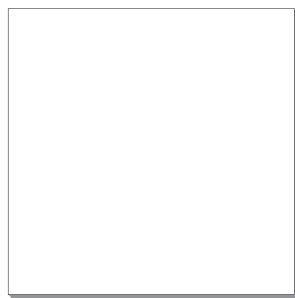

100x100 . 40"x40" RETT R11

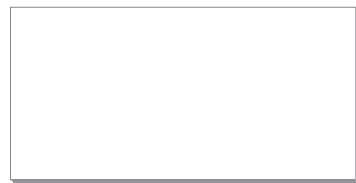

60x120 . 24"x48" RETT R11

 **19 mm - 13/16"**  
 spessore  
 thickness  
 épaisseur  
 stärke  
 толщина

Colors: *Temper Frost . Temper Golden . Temper Iron . Temper Rust*



Pezzi Speciali . Trims. Pièces Spéciales. Formstücke. Специальные изделия

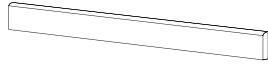

Battiscopa  
 6,5x100 . 2 9/16"x40" RETT

8,5 mm - 5/16"  
 spessore  
 thickness  
 épaisseur  
 stärke  
 толщина



Battiscopa  
 6,5x60 . 2 9/16"x24" RETT

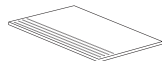

Step molato  
 30x60 . 12"x24" RETT

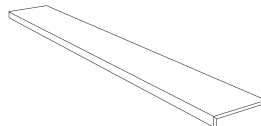

Gradone costa retta  
 30x120x3,3 . 12"x48"x1 5/16" RETT

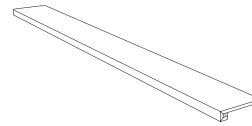

Gradone square assembled  
 30x120x3,3 . 12"x48"x1 5/16" RETT

10 mm - 3/8"  
 spessore  
 thickness  
 épaisseur  
 stärke  
 толщина

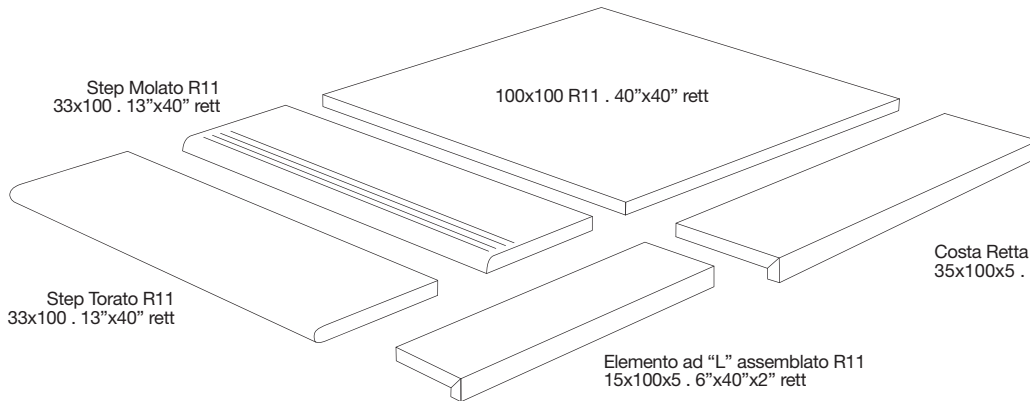

Step Molato R11  
 33x100 . 13"x40" rett

100x100 R11 . 40"x40" rett

Costa Retta R11  
 35x100x5 . 13 3/4"x40"x2" rett

Step Torato R11  
 33x100 . 13"x40" rett

Elemento ad "L" assemblato R11  
 15x100x5 . 6"x40"x2" rett

19 mm - 13/16"  
 spessore  
 thickness  
 épaisseur  
 stärke  
 толщина

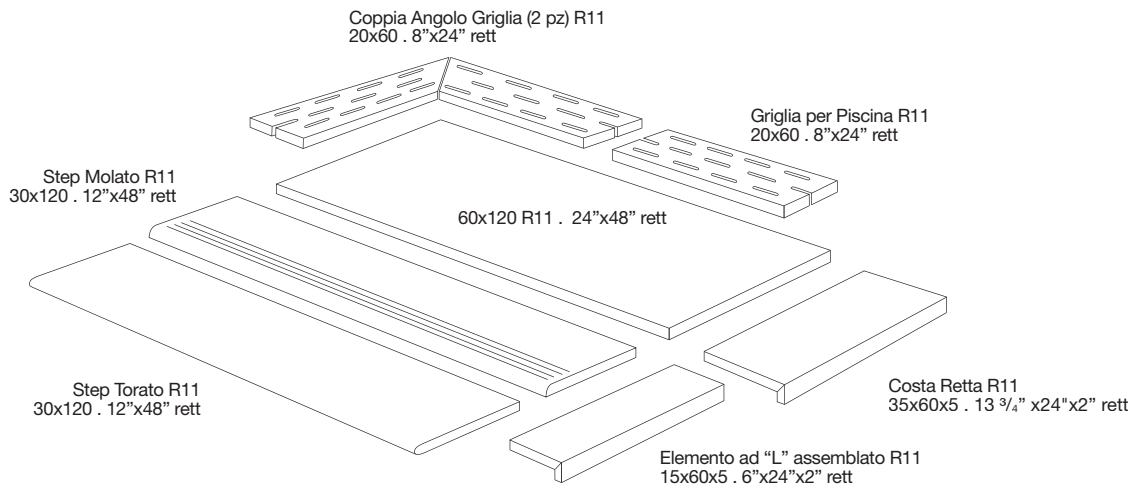

Coppia Angolo Griglia (2 pz) R11  
 20x60 . 8"x24" rett

Griglia per Piscina R11  
 20x60 . 8"x24" rett

Step Molato R11  
 30x120 . 12"x48" rett

60x120 R11 . 24"x48" rett

Costa Retta R11  
 35x60x5 . 13 3/4" x24"x2" rett

Step Torato R11  
 30x120 . 12"x48" rett

Elemento ad "L" assemblato R11  
 15x60x5 . 6"x24"x2" rett

# TEMPER GOLDEN

80x180 - 32"x72" . 120x120 - 48"x48" . 60x120 - 24"x48" . 30x120 - 12"x48" . 60x60 - 24"x24" . 30x60 - 12"x24" . 100x100 - 40"x40" . 50x100 - 20"x40"





# TEMPER COAL

80x180 - 32"x72" . 120x120 - 48"x48" . 60x120 - 24"x48" . 30x120 - 12"x48" . 60x60 - 24"x24" . 30x60 - 12"x24" . 100x100 - 40"x40" . 50x100 - 20"x40"



# TEMPER RUST

80x180 - 32"x72" . 120x120 - 48"x48" . 60x120 - 24"x48" . 30x120 - 12"x48" . 60x60 - 24"x24" . 30x60 - 12"x24" . 100x100 - 40"x40" . 50x100 - 20"x40"



# TEMPER ARGENT

80x180 - 32"x72" . 120x120 - 48"x48" . 60x120 - 24"x48" . 30x120 - 12"x48" . 60x60 - 24"x24" . 30x60 - 12"x24" . 100x100 - 40"x40" . 50x100 - 20"x40"



# TEMPER FROST

80x180 - 32"x72" . 120x120 - 48"x48" . 60x120 - 24"x48" . 30x120 - 12"x48" . 60x60 - 24"x24" . 30x60 - 12"x24" . 100x100 - 40"x40" . 50x100 - 20"x40"



# TEMPER IRON

---

80x180 - 32"x72" . 120x120 - 48"x48" . 60x120 - 24"x48" . 30x120 - 12"x48" . 60x60 - 24"x24" . 30x60 - 12"x24" . 100x100 - 40"x40" . 50x100 - 20"x40"

---



# TEMPER

Mosaici . Mosaics . Mosaïques . Mosaiken . Мозаика

## TEMPER FROST



MOSAICO INTRECCIO  
30x30 . 12"x12" RETT



MOSAICO METALLIC  
30x30 . 12"x12" RETT



MOSAICO BRICKS MIX  
24x40 . 9 1/16"x16" RETT

## TEMPER ARGENT

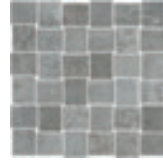

MOSAICO INTRECCIO  
30x30 . 12"x12" RETT



MOSAICO METALLIC  
30x30 . 12"x12" RETT



MOSAICO BRICKS MIX  
24x40 . 9 1/16"x16" RETT

 10 mm - 3/8"  
spessore  
thickness  
épaisseur  
stärke  
ТОЛЩИНА

## TEMPER IRON

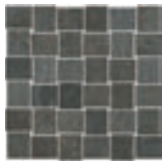

MOSAICO INTRECCIO  
30x30 . 12"x12" RETT



MOSAICO METALLIC  
30x30 . 12"x12" RETT



MOSAICO BRICKS MIX  
24x40 . 9 1/16"x16" RETT

## TEMPER COAL

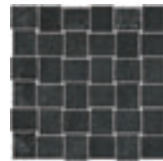

MOSAICO INTRECCIO  
30x30 . 12"x12" RETT



MOSAICO METALLIC  
30x30 . 12"x12" RETT



MOSAICO BRICKS MIX  
24x40 . 9 1/16"x16" RETT

## TEMPER GOLDEN



MOSAICO INTRECCIO  
30x30 . 12"x12" RETT



MOSAICO METALLIC  
30x30 . 12"x12" RETT

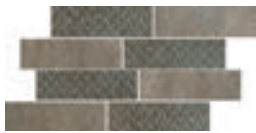

MOSAICO BRICKS MIX  
24x40 . 9 1/16"x16" RETT

## TEMPER RUST



MOSAICO INTRECCIO  
30x30 . 12"x12" RETT



MOSAICO METALLIC  
30x30 . 12"x12" RETT

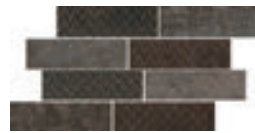

MOSAICO BRICKS MIX  
24x40 . 9 1/16"x16" RETT

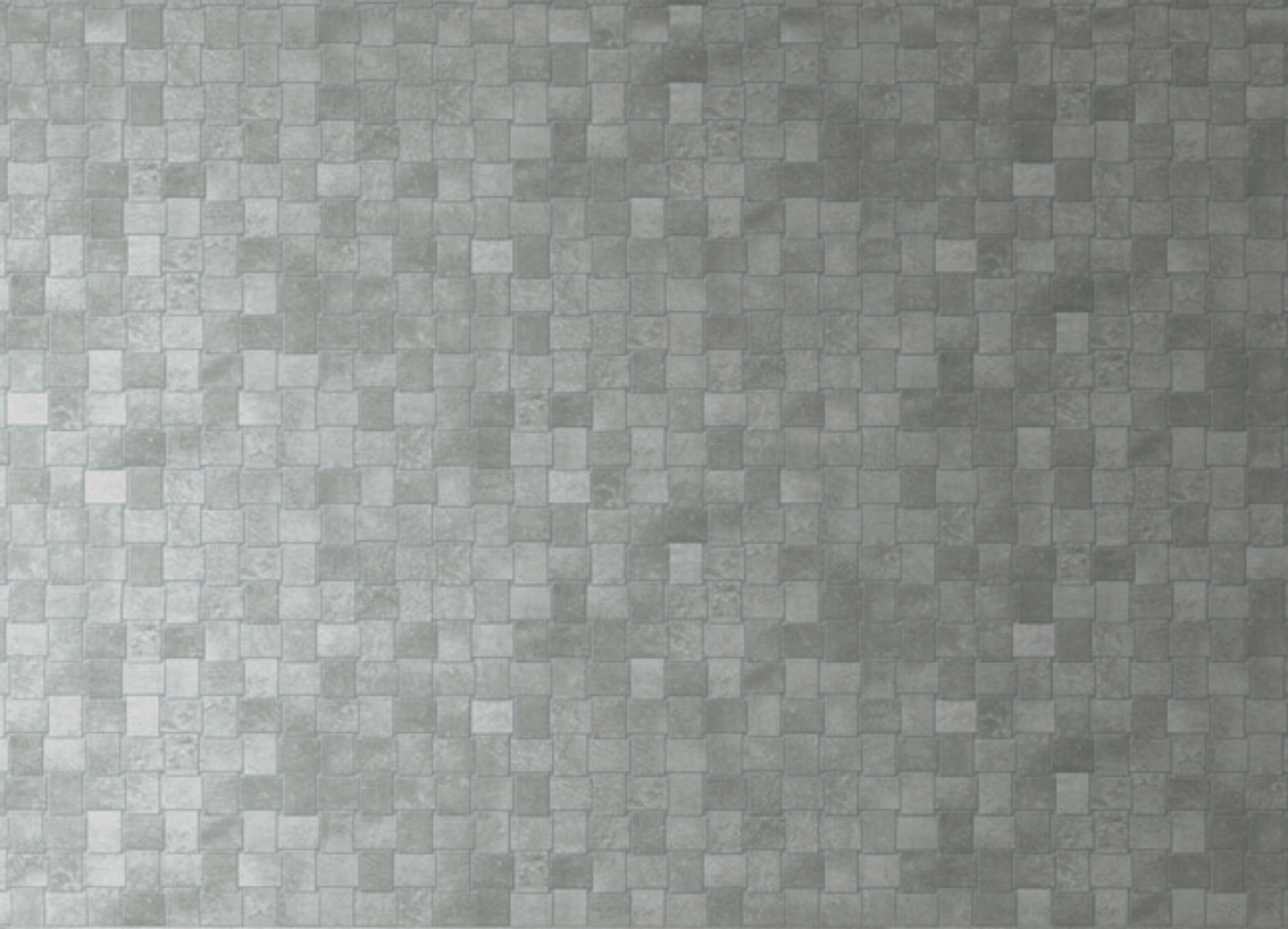

TEMPER ARGENT  
60x120 . 24"x48" RETT  
Mosaico Intreccio 30x30 . 12"x12" RETT

# TEMPER

Decori . Decors . Décors . Dekore . Декоры



BAMBOO SILVER ( base Argent) comp 2 pz  
120x120 . 48"x48" RETT

 **10 mm** - 3/8"  
spessore  
thickness  
épaisseur  
stärke  
толщина



BAMBOO BRONZE ( base Golden) comp 2 pz  
120x120 . 48"x48" RETT





Bamboo Bronze (base Golden) comp 2 pz 120x120 . 48"x48" RETT

51

# TEMPER

Decori . Decors . Décors . Dekore . Декоры

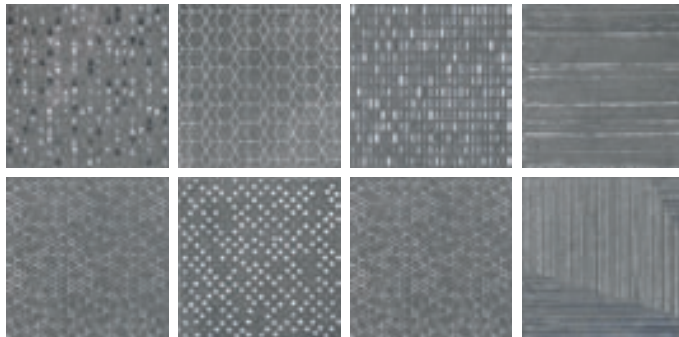

INSERTO WELD SILVER S/8  
30x30 . 12"x12" RETT

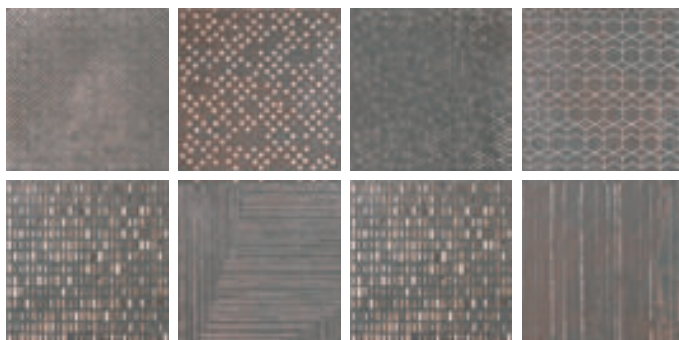

INSERTO WELD BRONZE S/8  
30x30 . 12"x12" RETT















10 mm - 3/8"  
spessore  
thickness  
épaisseur  
stärke  
толщина





Inserto Weld Bronze S/8 30x30 . 12"x12" RETT

**GRES PORCELLANATO SMALTATO COLORATO IN MASSA - ISO 13006 Bla GL**  
**GLAZED PORCELAIN STONEWARE WITH COLOURED BODY - GRÈS CÉRAME ÉMAILLÉ COLORÉ DANS LA MASSE**  
**GLASIERTES FEINSTEINZEUG IN DER MASSE GEFÄRBT - ГЛАЗУРОВАННЫЙ КЕРАМОГРАНИТ, ОКРАШЕННЫЙ ПО ВСЕЙ ТООЛЦИНЕ**

 UNI EN ISO 10545-2	<b>Aspetto superficiale</b> Surface appearance Aspect superficiel Oberflächenbeschaffenheit Вид поверхности	≥ 95%	Conforme Compliant Conforme Konform Соответствует		
	<b>Lunghezza e larghezza</b> Length and width Longueur et largeur Länge und Breite Длина и ширина	<b>Deviazione valore medio % rispetto a dimensione di fabbricazione.</b> Deviation of the average size for each tile from the work size (%). Écart dimensionnel moyen en % par rapport aux dimensions de fabrication. Abweichung des Durchschnittswertes in % hinsichtlich der Produktionsgröße. Отклонение средн. значения, % от производственных размеров > 410 cm <sup>2</sup> +/- 0,6% - ≤ 410 cm <sup>2</sup> +/- 0,75%		± 0,5% ± 2 mm	
		<b>Deviazione valore medio % rispetto a dimensione di fabbricazione.</b> Deviation of the average size from the average size to the 10 test specimens (%). Écart de valeur moyenne unitaire % en rapport à la valeur moyenne de 10 échantillons mesurés. Abweichung des Durchschnittswertes der einzelnen Fliesen in % hinsichtlich des Durchschnitts von 10 getesteten Mustern. Отклонение средн. значения отдельной плитки относительно средн. значения 10 измеренных образцов +/- 0,5%		± 0,5% ± 2 mm	
	<b>Rettilineità degli spigoli</b> Straightness of sides Rectitude des arêtes Kantengeradheit Прямолинейность кромок	+/- 0,5%		± 0,3% ± 1,5 mm	
	<b>Spessore / Thickness / Epaisseur/Stärke / Толщина</b>	+/- 5%		± 5% ± 0,5 mm	
 UNI EN ISO 10545-3	<b>Ortogonalità</b> Rectangularity Orthogonalité Rechtwinkligkeit Ортогональность	+/- 0,5%		± 0,3% ± 1,5 mm	
	 UNI EN ISO 10545-3	<b>Assorbimento d'acqua</b> Water absorption Absorption d'eau Wasseraufnahme Водопоглощение	≤ 0,5% GRUPPO Bla GL	E ≤ 0,1%	
	 UNI EN ISO 10545-3	<b>Resistenza della superficie (scala MOHS)</b> Scratch hardness (MOHS scale) Dureté de la surface (échelle MOHS) Oberflächenhärte (MOHS skala) Поверхностная прочность по (шкале Мооса)	EN 101	> 6	
	 UNI EN ISO 10545-4	<b>Resistenza a flessione e forza di rottura</b> Modulus of rupture and breaking strength résistance à la flexion et force de rupture Biegefestigkeit und Bruchlast Прочность на изгиб Модуль жесткости	S ≥ 1300 N	S ≥ 1300 N	
			R ≥ 35 N/mm <sup>2</sup>	R ≥ 35 N/mm <sup>2</sup>	
 UNI EN ISO 10545-7	<b>Resistenza alla abrasione della superficie di piastrelle smaltate</b> Resistance to surface abrasion of glazed tiles Résistance à l'abrasion de la surface des carreaux émaillés Widerstand gegen Abrieb der Oberfläche der glasierten Fliesen Стойкость глазурованной плитки к поверхностному истиранию	Come dichiarato dal produttore See manufacturer's declaration Selon déclaration du producteur Entsprechend der Herstellerangaben Как указано изготовителем	Argent/Frost/ Goldten Rust Classe 4 Classe 4 Class 4 Classe 4 Gruppe 4 Klasse 4 Classe 3 Classe 3 Class 3 Classe 3 Gruppe 3 Klasse 3	Coal/Iron/ Rust Classe 3 Classe 3 Class 3 Classe 3 Gruppe 3 Klasse 3	
 UNI EN ISO 10545-8	<b>Coefficiente di dilatazione termica lineare</b> Linear thermal expansion coefficient Dilatation thermique linéaire Lineare Wärmeausdehnung Коэффициент линейного теплового расширения	Come dichiarato dal produttore See manufacturer's declaration Selon déclaration du producteur Entsprechend der Herstellerangaben Как указано изготовителем	Metodo disponibile Method available Méthode disponible Verfügbares verfahren Определяется производителем		
 UNI EN ISO 10545-9	<b>Resistenza allo shock termico</b> Thermal shock resistance Résistance au choc thermique Temperaturwechselbeständigkeit Стойкость к тепловым перепадам	Nessun campione deve presentare alterazioni No sample must show visible alteration Aucun carreau ne doit présenter d'altération Kein Muster darf sichtbare Veränderungen zeigen Никакой образец не должен показывать изменений	Resistente Résistant Résistant Widerstandsfähig Устойчивый		
 UNI EN ISO 10545-12	<b>Resistenza al gelo</b> Frost resistance Résistance au gel Frostbeständigkeit Морозостойкость	Non devono presentare difetti visibili No sample must show visible defect Aucun carreau ne doit présenter de défaut Muster dürfen keine sichtbaren Schäden zeigen Не должны обнаруживать видимые дефекты	Ingelivo Frost proof Ingelif Frostsicher Морозостойкость		
 UNI EN ISO 10545-13	<b>Resistenza all'attacco chimico (tranne acido fluoridrico)</b> Resistance to chemical attack (except hydrofluoric acid) Résistance à l'attaque chimique (sauf acide fluoridrique) Säure- und Laugenbeständigkeit (außer Flußsäure) Стойкость к бытовым химикатам	Nessun campione deve presentare alterazioni No sample must show visible alteration Aucun carreau ne doit présenter d'altération Muster dürfen keine sichtbaren Veränderungen zeigen Никакой образец не должен показывать изменений	Classe 5 Class 5 Classe 5 Classe 5 Gruppe 5 Klasse 5	A-HA-LA A-HA-LA A-HA-LA A-HA-LA A-HA-LA	
 UNI EN ISO 10545-14	<b>Resistenza alle macchie di piastrelle smaltate</b> Resistance to stains of glazed tiles Résistance aux taches des carreaux émaillés Widerstand gegen Fleckenbildner der glasierten Fliesen Стойкость глазурованной плитки к образованию пятен	Nessun campione deve presentare alterazioni No sample must show visible alteration Aucun carreau ne doit présenter d'altération Muster dürfen keine sichtbaren Veränderungen zeigen Никакой образец не должен показывать изменений	Classe 5 Class 5 Classe 5 Classe 5 Gruppe 5 Klasse 5		
 UNI EN ISO 10545-14   UNI EN ISO 10545-14 B.C.R.A. REPCCE 6/81 DIN 51130 DIN 51097	<b>Resistenza alla scivolosità. Coefficiente di attrito medio</b> Skid resistance. Average coefficient of friction Résistance au glissement. Coefficient de frottement moyen Rutschfestigkeit. Mittlerer Reibungswert Сопротивление скольжению. Средний коэффициент трения	B.C.R.A.	M <sub>1</sub> ≥ 0,40		
		DIN 51130	R10	R11	
		DIN 51097	R10 Classe B Class B Classe B Gruppe B Klasse B	R11 Classe C Class C Classe C Gruppe C Klasse C	
		DCOF Acu Test	M <sub>2</sub> ≥ 0,42		

## imballaggi

Packing  
Emballage  
Verpackung  
Упаковка

						
	PCS/BOX	SQM/BOX	KGS/BOX	BOXES/PALLET	SQM/PALLET	KGS/PALLET
80x180 . 32"x72" RETT	1	1,44	29,30	36	51,84	1.100
120x120 . 48"x48" RETT	1	1,44	32,00	40	57,60	1.335
100x100 . 40"x40" RETT	1	1,00	20,65	42	42,00	900
100x100 . 40"x40" INSERTO SCRATCH RETT	1	1,00	20,65	42	42,00	883
50x100 . 20"x40" RETT	2	1,00	20,65	42	42,00	883
60x120 . 24"x48" RETT	2	1,44	32,00	30	43,20	976
	2	1,44	32,00	36	51,84	1.168
30x120 . 12"x48" INSERTO SCRATCH RETT	4	1,44	32,00	24	34,56	1.168
60x60 . 24"x24" RETT	3	1,08	24,00	40	43,20	976
30x60 . 12"x24" RETT	6	1,08	24,00	40	43,20	976
100x100 . 40"x40" <b>19mm</b>	1	1,00	42,50	21	21,00	926
60x120 . 24"x48" <b>19mm</b>	2	0,72	30,60	36	25,92	1.118



Posa consigliata con una sfalsatura tra ciascun listello non superiore al 25% della lunghezza.  
When laying, you are recommended not to stagger the strips by more than 25% of the length.  
Pose conseillée avec un décalage entre chaque listel non supérieur au 25% de la longueur.  
Wir empfehlen eine Verlegung im Viertelverband.  
Рекомендуется укладка с разномсом элементов друг относительно друга, не превышающим 25% длинны элемента.



Per i grandi formati è consigliata la posa con l'utilizzo di distanziatori livellanti, tipo Levelling System di Raimondi.  
We suggest to lay large sizes with "levelling spacers" like the Raimondi's Levelling System.  
Pose conseillée avec un décalage entre chaque listel non supérieur au 25% de la longueur.  
Wir empfehlen fuer die Verlegung der grossen Formaten die Benutzung von Autolivellierungssysteme, wie z.B. Raimondi Levelling System.  
Для выклейки больших форматов советуем использовать распорную выравнивающую деталь типа Levelling System di Raimondi.

### NOTE TECNICHE - TECHNICAL NOTES - NOTES TECHNIQUES - TECHNISCHE ANMRKUNGEN - ТЕХНИЧЕСКИЕ ЗАМЕЧАНИЯ

Tutti i formati sono nominali. Cercom Ceramiche si riserva la facoltà di modificare in qualunque momento le informazioni e le caratteristiche illustrate nel presente catalogo, che non sono comunque da ritenere legalmente vincolanti. I colori e le caratteristiche estetiche dei prodotti sono quanto più possibile vicini a quelli reali, nei limiti consentiti dai processi di stampa.

All sizes are nominal. Cercom Ceramiche reserves the right to modify the information and the characteristics illustrated in this catalogue (which are in any case not legally binding) at any moment. The colours and appearance features of the products are as close as possible to reality, within the limitation of the printing process.

Tous les formats sont nominaux. Cercom Ceramiche se réserve la faculté de modifier à tout moments les informations et les caractéristiques figurant dans le présent catalogue, lesquelles niengagent pas par le fabricant au plan légal. Les couleurs et les caractéristiques esthétiques sont fidèles aux couleurs et caractéristiques réelles dans les limites des procédés d'impression.

Alle Formate sind Nennwerte. Die Firma Cercom Ceramiche behält sich vor, die in diesem Katalog enthaltenen Informationen und Eigenschaften jederzeit zu ändern; sie gelten auf keinen Fall als gesetzlich bindend. Die Farben und ästhetischen Eigenschaften der Produkte kommen innerhalb der Möglichkeiten der Druckverfahren den tatsächlichen Eigenschaften so weit wie möglich nahe.

Все форматы являются номинальными. Cercom Ceramiche оставляет за собой изменять в любой момент данные и характеристики, приведенные в настоящем каталоге, которые в любом случае не считаются юридически обязательными. Цветовая окраска и эстетические характеристики изделий приближаются как можно больше к реальным, в пределах, допускаемых процессами печати

### CONSIGLI PER LA POSA - LAYING SUGGESTIONS - CONSEILS POUR LA POSE - VERLEGEHINWEISE - РЕКОМЕНДАЦИИ ПО УКЛАДКЕ

Stendere a terra alcuni metri (almeno 3 mq) per controllare l'effetto d'insieme. Posare il materiale attingendo da più scatole controllandone accuratamente calibro, tonalità e scelta. • Nella posa è consigliabile lasciare una fuga di 2 mm fra le piastrelle utilizzando stucco in tono. • La posa modulare è consigliata con una fuga di almeno 2 mm. • È comunque compito del progettista stabilire, in funzione della struttura e della destinazione d'uso del piano di calpestio, il corretto modo di applicazione delle piastrelle.

Lay some pieces of product (at least 3 sqm) to check the overall effect. Lay the material taking it from several boxes and carefully check its size accuracy, shade and material sorting. • In the lay-out is advisable to leave at least 2 mm joint between each tile and fill with grout of the same colour as the tile. • We recommend modular laying with a 2 mm - <sup>2</sup>/<sub>32</sub> joint. • However, the designers has to establish the correct way of application of the tiles depending on the structure and the foreseen utilization of the floor.

Appuyer sur le sol quelques pieds (au moins 2 mc) pour apprécier l'effet global. Poser le matériel en le prenant de plusieurs boîtes et en contrôlant l'épaisseur, les nuances et la qualité des différentes pièces. • Lors de la pose, on recommande de laisser un joint de 2 mm entre les carreaux en utilisant un mastic du même ton. • La pose modulaire est calculée avec un joint de 2 mm. • D'ailleurs c'est le concepteur qui doit établir, sur la base de la structure et de la destination d'emploi du plan de piétinement, le procédé d'application correct des carreaux.

Eine Quadratmeter (min. 2 qm) auf dem Boden legen, um die Gesamtwirkung nachzuprüfen. Wir empfehlen Fliesen aus mehreren Kartons zu verlegen, nach einer sorgfältigen Prüfung des Kalibers, des Farbtons und der Sortierung. • Deswegen werden eine min. 2 mm Fuge zwischen den Fliesen und ein weiss oder grauer Kitt empfohlen. • Die Modulverlegung wird mit einer Mindestfuge von 2 mm empfohlen. Es ist auf jeden Fall Aufgabe des Planers, nach der Struktur und dem Verwendungszweck der Trittläche, die richtige Verlegeart der Fliesen zu bestimmen.

Разложить изделия на полу для проверки общего эффекта. Укладывать материал, тщательно проверяя калибр, тональность и сорт. • При укладке рекомендуется оставлять между плитками зазор в 2 мм, используя подходящую по тону замазку. • Модульную укладку рекомендуется выполнять со швом не менее 2 мм. • В любом случае является задачей проектировщика, в зависимости от структуры и назначения, определять соответствующий способ укладки плитки.



<b>CE</b>
<b>GRUPPO ROMANI S.P.A. INDUSTRIE CERAMICHE</b> VIA A. VOLTA 9, 23/25 42013 CASALGRANDE (RE)
05 001CPR2013-07-01
<b>EN 14411:2012</b>
<b>Piastrelle di ceramica pressate a secco, con assorbimento di acqua <math>E_w \leq 0,5\%</math>, per pavimentazioni interne ed esterne.</b>
<b>Dry pressed ceramic tile, with water absorption <math>E_w \leq 0,5\%</math>, for internal and external floorings.</b>



© Copyright 2019 Gruppo Romani S.p.A.

Gruppo Romani S.p.A. Industrie Ceramiche  
[www.grupporomanispa.com](http://www.grupporomanispa.com)







DAL 1975

**CERCOM CERAMICHE**

[www.cercomceramiche.it](http://www.cercomceramiche.it)

Via A. Volta 23/25 - 42013 Casalgrande (RE) Italy  
Tel. +39-0522-998411/911  
Fax Italy +39-0522-998910  
Fax Export +39-0522-996218

