

SELECT PRO BOLT-ON DIGITAL GATE LOCK DOUBLE-SIDED

Specification Sheet **DGL**

FEATURES

- Power-free: Mechanical keypad eliminates the need for electricity or batteries.
- Enhanced security: The latchbolt extends up to 20mm into the gate post, offering increased security and greater tolerance.
- Highly adaptable: Adjustable latchbolt length accommodates both inward and outward-opening gates.
- Weatherproof durability: Successfully tested to withstand over 1,000 hours of salt spray, ensuring resistance to the elements.
- Single-sided keypad option also available.



PRODUCT DETAILS

Product code	Description
DGL01	To fit 10-30mm (½" - 1 ¼") gate frames
DGL02	To fit 40-60mm (1 ½" - 2 ¼") gate frames

INCLUDED IN THE BOX

- 1X3mm hex key
- M8 fixing bolts
- Face plate
- Latchbolt
- Strike plate (self-drilling fasteners)
- Code changing pack

INSTALLATION

1. Drill 2 x 9mm (3/8") holes at 92mm (3 2/3") centres for fixing bolts provided.
2. Drill a 18mm (¾") clearance hole for the latchbolt at 22mm (7/8") centres up from the bottom fixing hole.
3. Fix the lock in place using stainless steel clamp plate, bolt support plate and 2 stainless steel countersunk fixing bolts supplied.
4. Drill clearance hole in gate post to receive deadbolt/latchbolt. Slot this hole vertically to allow for gate sag- fix strike plate and bed back so the latchbolt slides smoothly.
5. Ensure latchbolt moves freely without binding on gate or frame.

HOW TO ADJUST To adjust latchbolt length insert 3mm long arm hex key (supplied) into end of bolt and release locking screw. Rotate bolt as required and re-tighten locking screw. Lubricate with light oil periodically

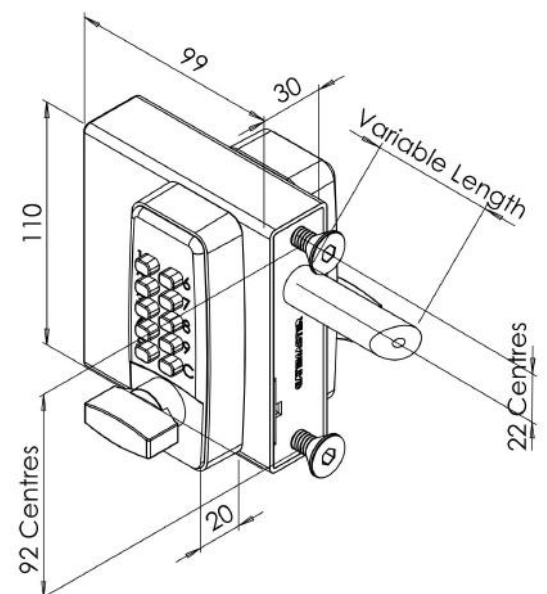
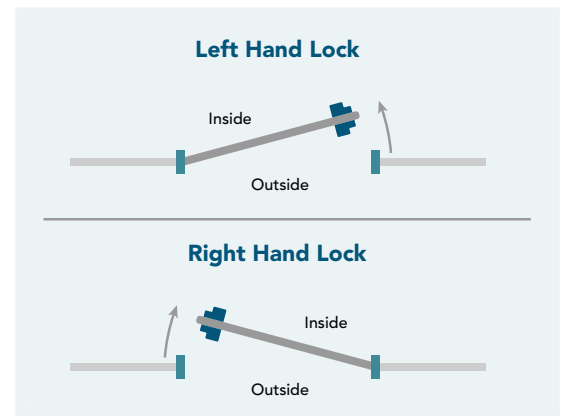

SELECT PRO BOLT-ON DIGITAL GATE LOCK DOUBLE-SIDED

Specification Sheet

DGL

LOCK CODE: C

TO CHANGE THE CODE

1. Check the original code is working on both keypads To remove the keypads – Insert a flat screwdriver into the hole in the forend plate and lever out the keypad retaining plate. This will release one keypad. Slide out the lock mechanism and the other keypad can then be removed by accessing the screws through the lockcase.
2. Turn the keypad over and remove the 4 red screws.
3. Lift off the covering panel. Be careful as there are 10 springs attached to this panel. Note that the red tumblers relate to the code shown above. Also note that the C tumbler is uncoloured and should not be removed.
4. To change the code hold the keypad with the code buttons down and depress & hold the C button (if this is not done you may damage some of the internal components). Reposition the tumblers to the new code (red tumblers are coded and blue tumblers are uncoded). Ensure that the square cut-out on each tumbler is facing the outside of the lock body, also ensure that the coloured mark is facing upwards. If any one tumbler is upside down or the wrong way round the lock will not work and if forced will break the internal components. The code must always start with a 'C'

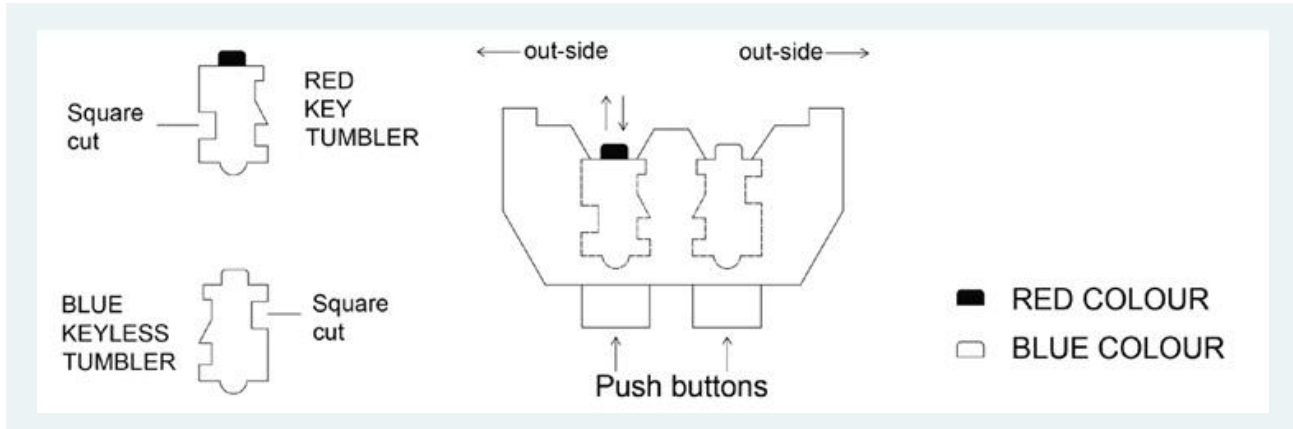

5. Replace the covering panel and tighten the 4 red screws.
6. The code is now changed, check to see that it is working correctly and make a note of the code for future reference. Once satisfied that the lock is working correctly refit keypads to the lock case.

MAINTENANCE

3 Monthly:

1. Remove keypads from the lock.
2. Spray the inside of the lock thoroughly with WD40 or equivalent, through the tumbler holes at the back of the lock.
3. Spray all the fixing accessories and the latch with WD40 or equivalent.
4. Push each of the buttons and rotate the knob several times to make sure the lock is working smoothly.