















WPC-WANDPANEELE



Montageanleitung

Lieferumfang-2.65M

1/3

Nr.	Bild		Mg.
K1		 32X40-2397	1
K2		 32X40-2323	1
K3		 40X60-2485	1
K6		 34X50-2323	1
K7		 6X50-2323	1



Nr.	Bild		Mg.
L1		 188X28-2316	1
L2		 149X28-2316	1

Nr.	Bild	Mg.
S5	 4x16	16
S8	 8x100	4

Nr.	Bild	Mg.
Z5	 PH2	1

Lieferumfang-2.65M

2/3

Nr.	Bild		Mg.
L1		 188X28-2316	6

3/3

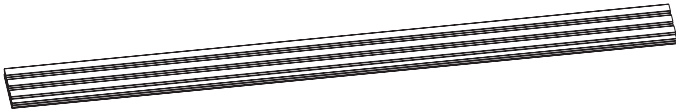



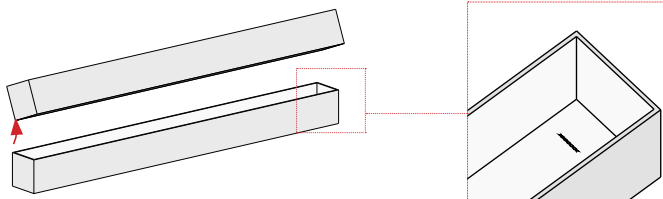





Nr.	Bild		Mg.
L1		 188X28-2316	6





Auf der Innenseite des Kartons befindet sich eine Produktverfolgungsnummer (siehe Abbildung unten). Für einen besseren und effizienteren Kundendienst in der Zukunft machen Sie bitte ein Foto der Tracking-Nummer, bevor Sie den Karton entsorgen, und speichern Sie dieses.





Lieferumfang-3M

1/3

Nr.	Bild		Mg.
K1		 32X40-2701	1
K2		 32X40-2323	1
K3		 40X60-2790	1
K6		 34X50-2323	1
K7		 6X50-2323	1

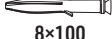

Nr.	Bild		Mg.
L1		 188X28-2316	3
L2		 90X28-2316	1

Nr.	Bild	Mg.
S5	 4x16	16
S8	 8x100	4



Nr.	Bild	Mg.
Z5	 PH2	1

Lieferumfang-3M

2/3

Nr.	Bild		Mg.
L1		 188X28-2316	6

3/3





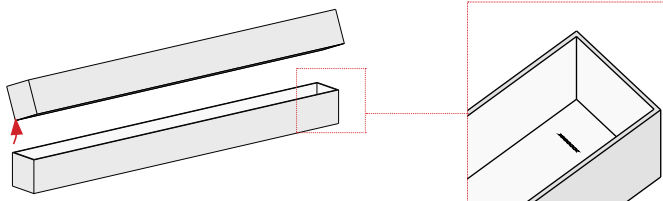







Nr.	Bild		Mg.
L1		 188X28-2316	6



Auf der Innenseite des Kartons befindet sich eine Produktverfolgungsnummer (siehe Abbildung unten). Für einen besseren und effizienteren Kundendienst in der Zukunft machen Sie bitte ein Foto der Tracking-Nummer, bevor Sie den Karton entsorgen, und speichern Sie dieses.





Lieferumfang-3.6M

1/4

Nr.	Bild		Mg.
K1		 32X40-1655	2
K2		 32X40-2323	1
K4		 40X60-1700	1
K5		 40X60-1700	1
K6		 34X50-2323	1
K7		 6X50-2323	1



Nr.	Bild		Mg.
L2		 165X28-2316	1

Nr.	Bild	Mg.
S5	 4x16	20
S8	 8x100	6

Nr.	Bild	Mg.
Z5	 PH2	1

Lieferumfang-3.6M

2/4

Nr.	Bild		Mg.
L1		 188X28-2316	6

3/4

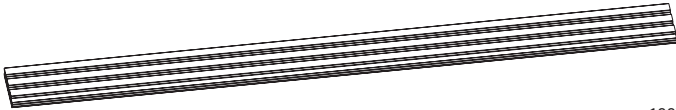
Nr.	Bild		Mg.
L1		 188X28-2316	6

4/4

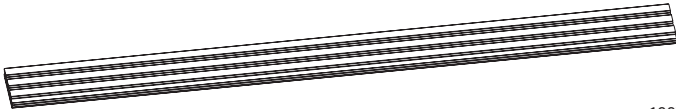



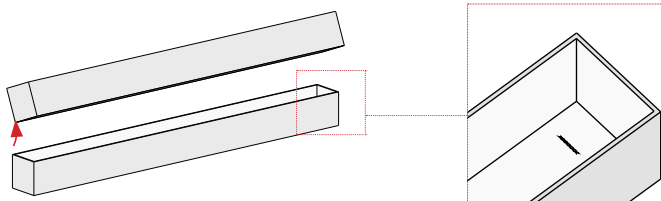







Nr.	Bild		Mg.
L1		 188X28-2316	6



Auf der Innenseite des Kartons befindet sich eine Produktverfolgungsnummer (siehe Abbildung unten). Für einen besseren und effizienteren Kundendienst in der Zukunft machen Sie bitte ein Foto der Tracking-Nummer, bevor Sie den Karton entsorgen, und speichern Sie dieses.



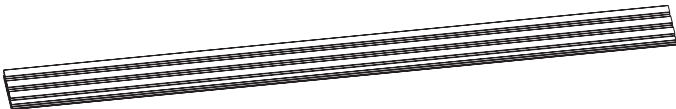

Lieferumfang-4M

1/4

Nr.	Bild		Mg.
K1		 32X40-1808	2
K2		 32X40-2323	1
K4		 40X60-1853	1
K5		 40X60-1853	1
K6		 34X50-2323	1
K7		 6X50-2323	1



Nr.	Bild		Mg.
L1		 188X28-2316	2
L2		 115X28-2316	1

Nr.	Bild	Mg.
S5	 4×16	20
S8	 8×100	6

Nr.	Bild	Mg.
Z5	 PH2	1

Lieferumfang-4M

2/4

Nr.	Bild		Mg.
L1		 188X28-2316	6

3/4

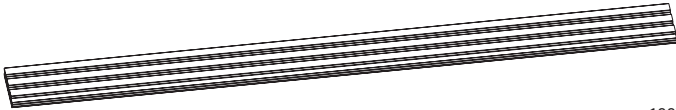
Nr.	Bild		Mg.
L1		 188X28-2316	6

4/4

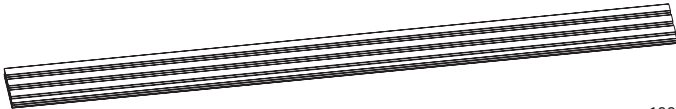
Nr.	Bild		Mg.
L1		 188X28-2316	6

Auf der Innenseite des Kartons befindet sich eine Produktverfolgungsnummer (siehe Abbildung unten). Für einen besseren und effizienteren Kundendienst in der Zukunft machen Sie bitte ein Foto der Tracking-Nummer, bevor Sie den Karton entsorgen, und speichern Sie dieses.

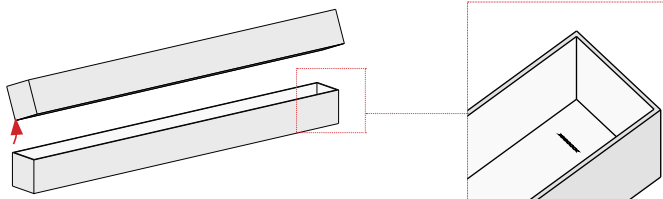

Montage

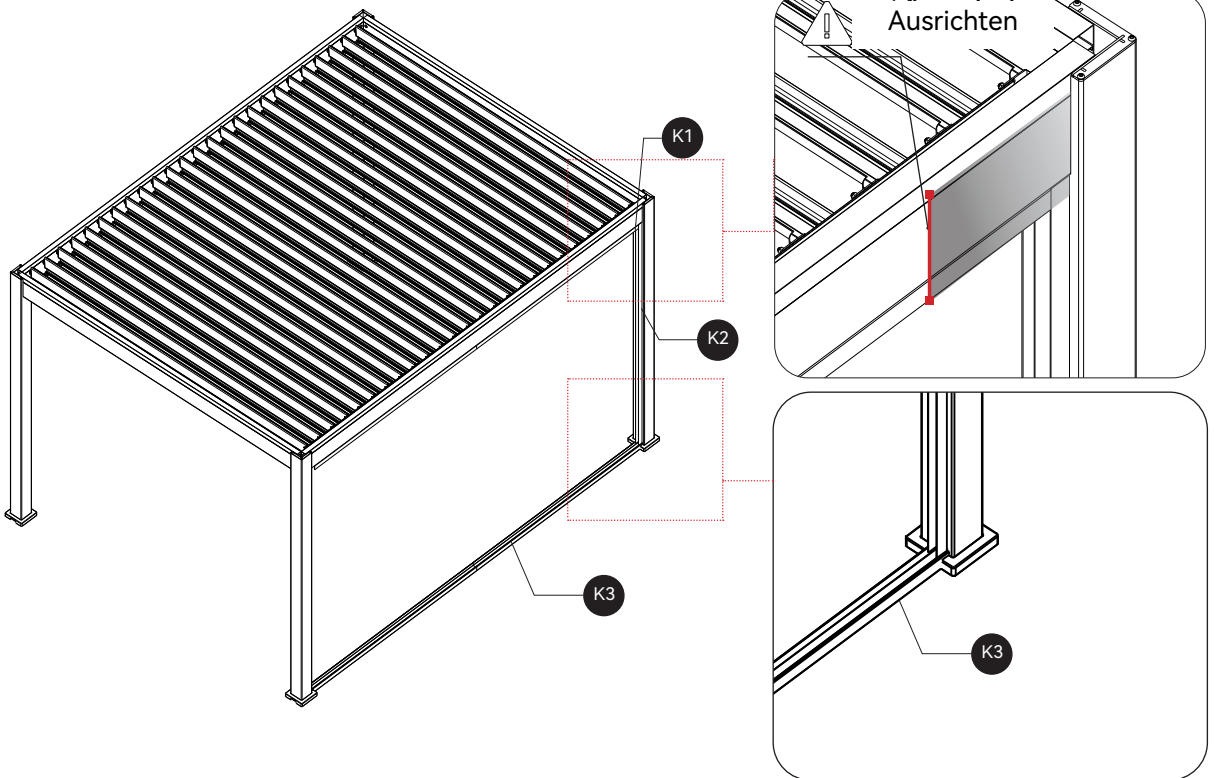
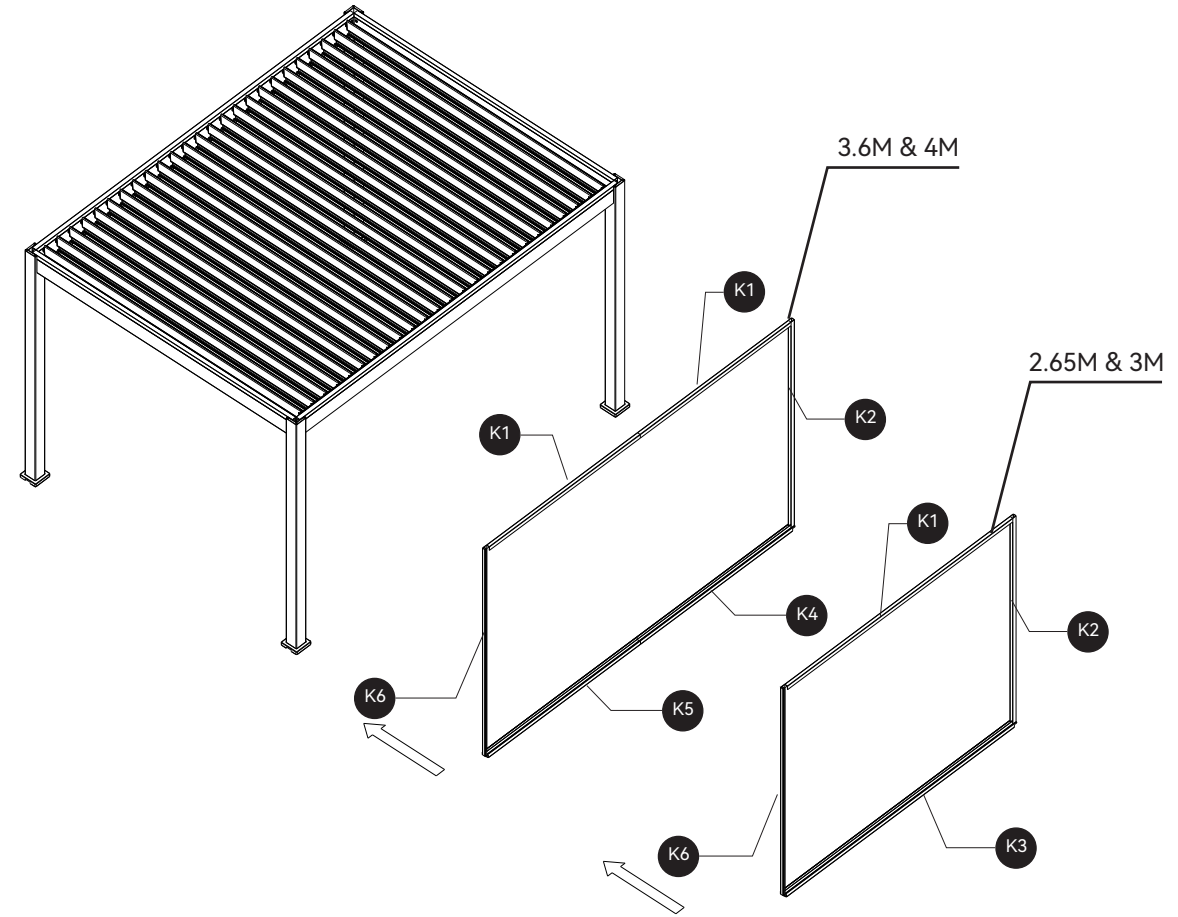

Montage

1. Montage des Rahmens

- Legen Sie **K3/K4** auf den Boden, um die Positionierung von **K2** zu erleichtern.
- Positionieren Sie **K2** gemäß der Abbildung und befestigen Sie es mit Schrauben.
- Montieren Sie **K1** und **K6** und verschrauben Sie diese fest.
- Befestigen Sie **K4** mit geeigneten Schwerlastdübeln (Expansionsbolzen) im Boden.

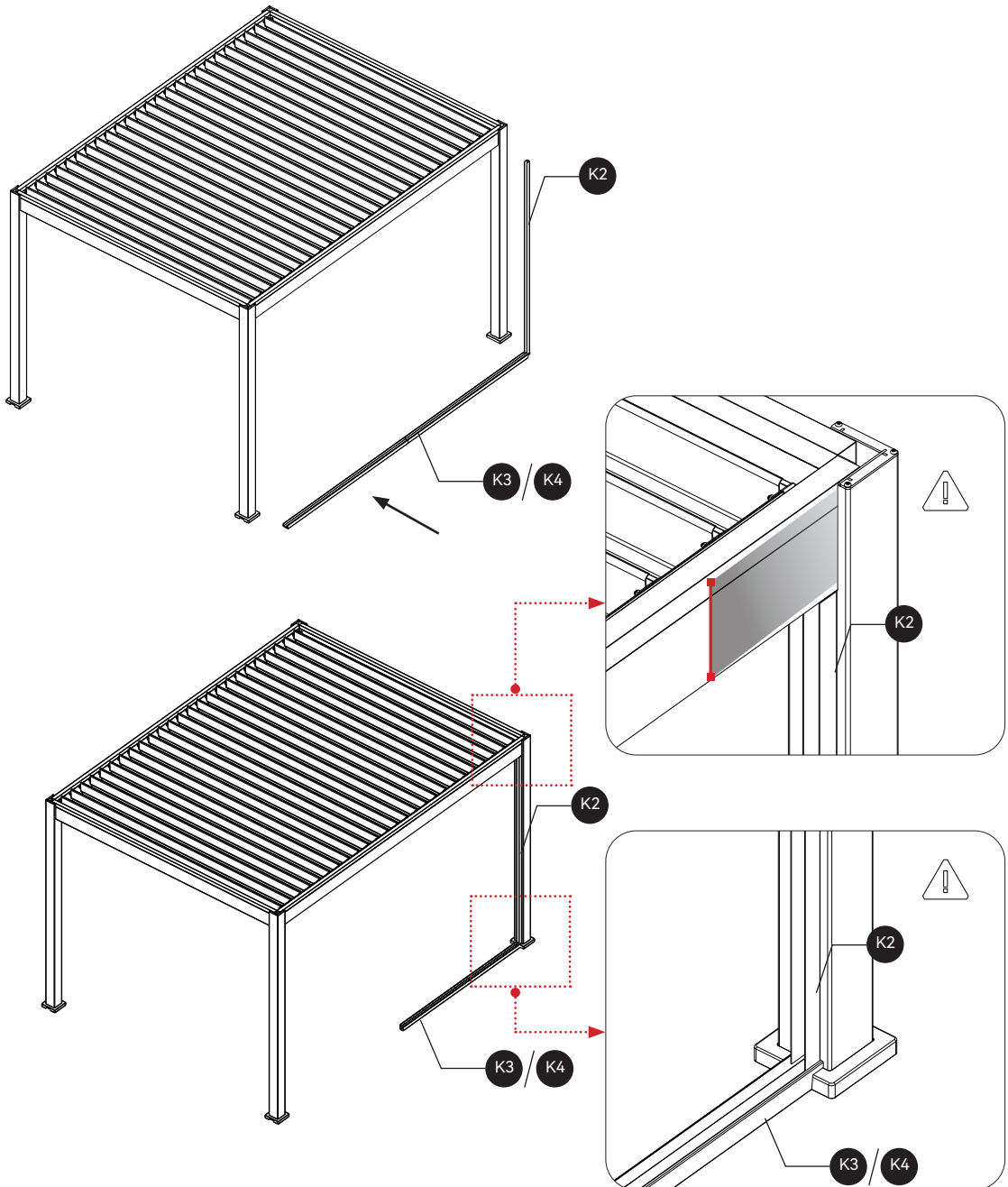

Montage

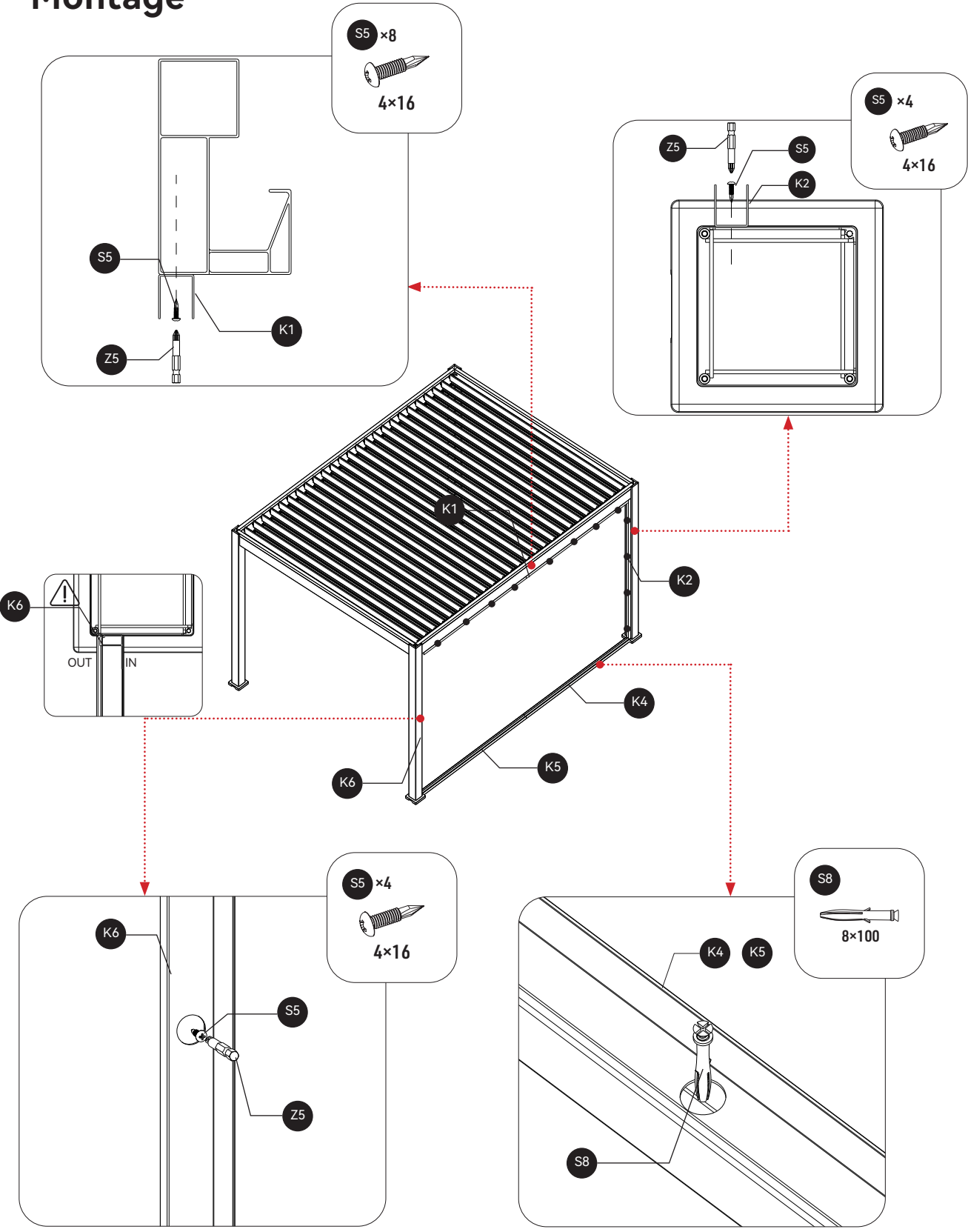

Montage

2. Montage der WPC-Dielen

Nach der Montage des Rahmens installieren Sie die WPC-Paneele wie unten dargestellt.

a. Setzen Sie **L1** schräg in **K2** ein.

b. Montieren Sie anschließend die restlichen WPC-Paneele (alle vom Typ **L1**) nacheinander.

c. Die letzte Diele ist **L2**. Nach der Montage decken Sie **K6** mit **K7** ab und befestigen dieses mit Schrauben.

Hinweis: Die Dielen werden über Nut-und-Feder-Verbindungen miteinander verbunden.

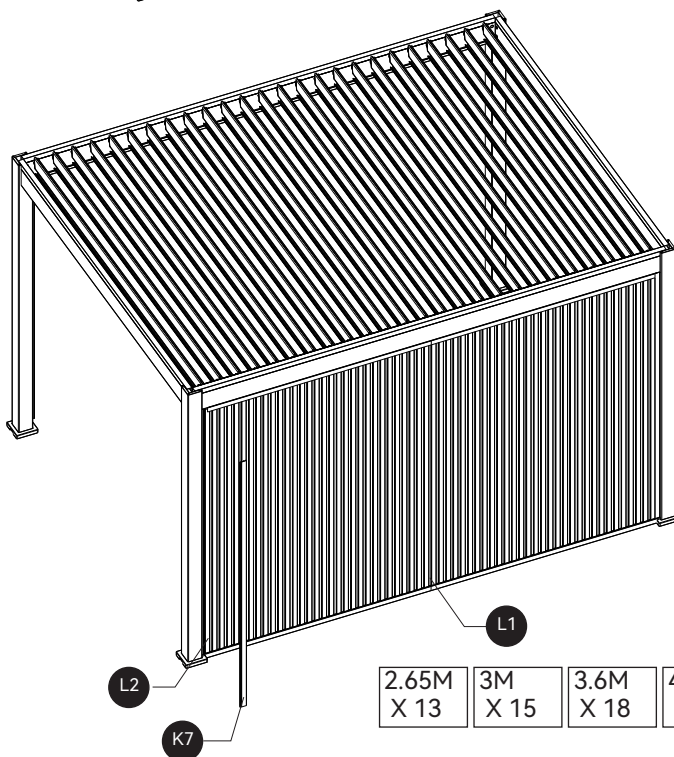
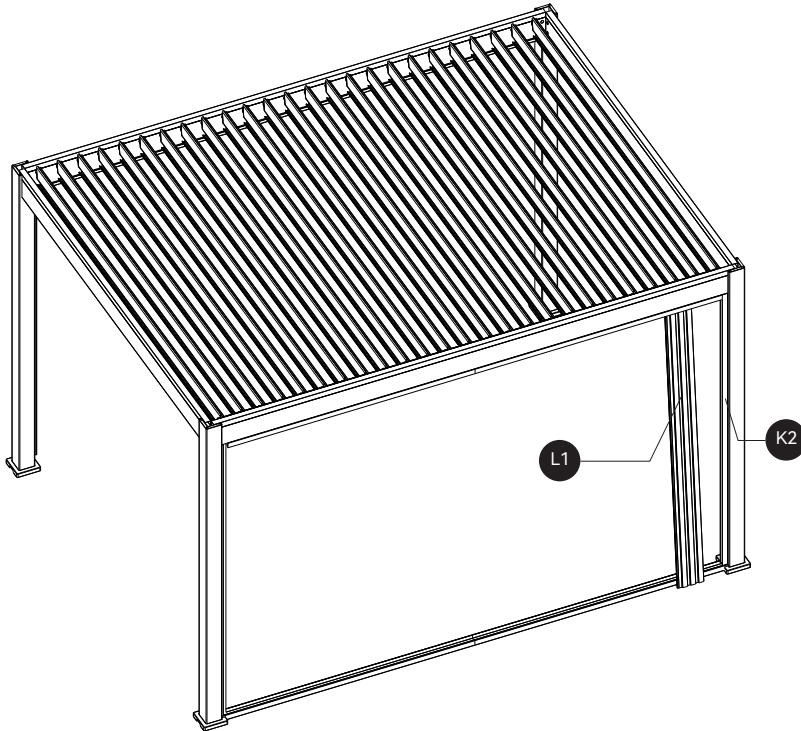

2.65M X 13	3M X 15	3.6M X 18	4M X 20
---------------	------------	--------------	------------

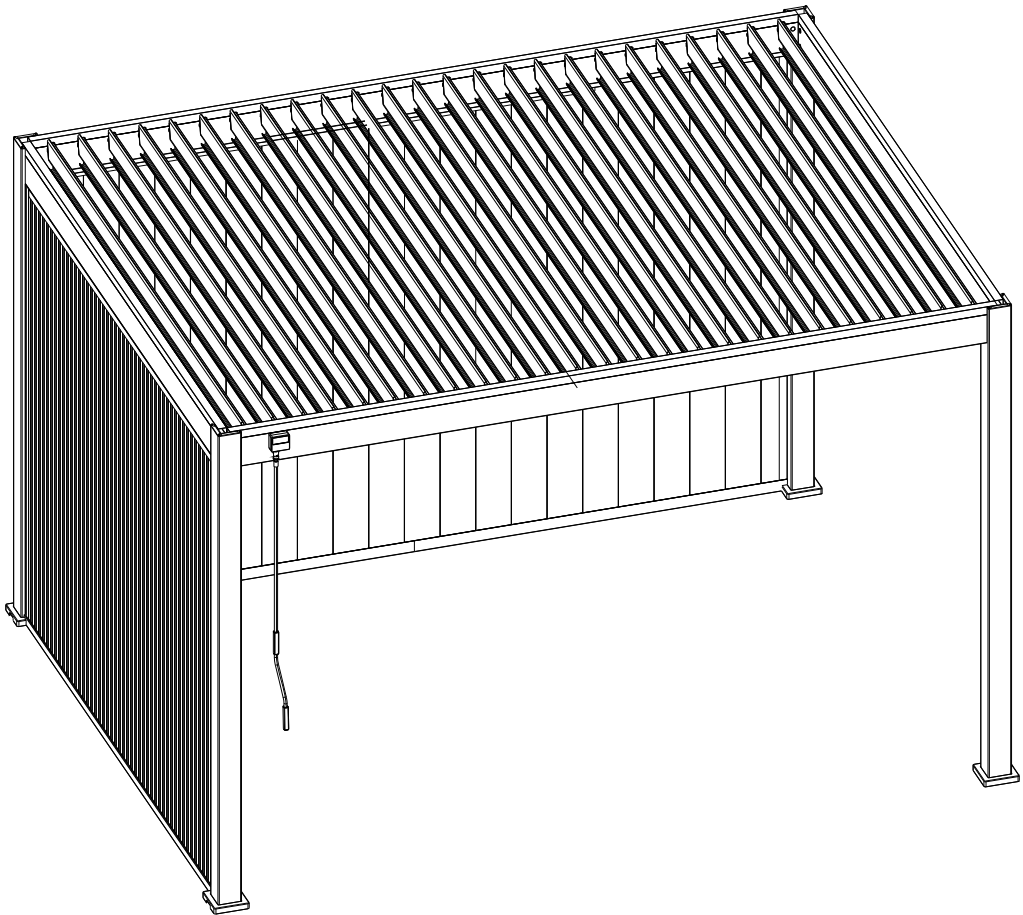















WPC WALL PANEL



Assembly Instructions

Parts List-2.65M

1/3

REF	PICTURE		QTY
K1		 32X40-2397	1
K2		 32X40-2323	1
K3		 40X60-2485	1
K6		 34X50-2323	1
K7		 6X50-2323	1

REF	PICTURE		QTY
L1		 188X28-2316	1
L2		 149X28-2316	1

REF	PICTURE	QTY
S5	 4x16	16
S8	 8x100	4

REF	PICTURE	QTY
Z5	 PH2	1

Parts List-2.65M

2/3

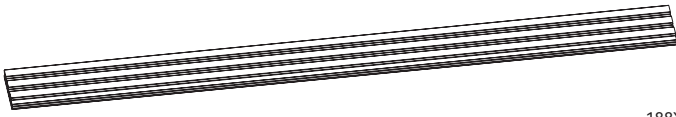
REF	PICTURE		QTY
L1		 188X28-2316	6

3/3

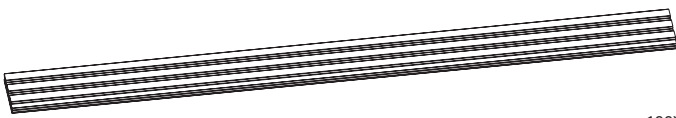



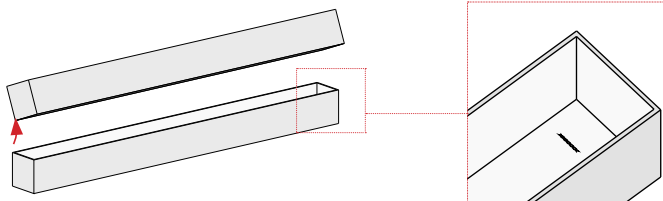





REF	PICTURE		QTY
L1		 188X28-2316	6





There is a Product Tracking Number in the inner side of the carton(see below diagram). For better and efficient after-sales in the future, when tear down the carton box, please take a photo of the Tracking Number and save the photo.





Parts List-3M

1/3

REF	PICTURE		QTY
K1		 32X40-2701	1
K2		 32X40-2323	1
K3		 40X60-2790	1
K6		 34X50-2323	1
K7		 6X50-2323	1



REF	PICTURE		QTY
L1		 188X28-2316	3
L2		 90X28-2316	1

REF	PICTURE	QTY
S5	 4x16	16
S8	 8x100	4



REF	PICTURE	QTY
Z5	 PH2	1

Parts List-3M

2/3

REF	PICTURE		QTY
L1		 <small>188X28-2316</small>	6

3/3





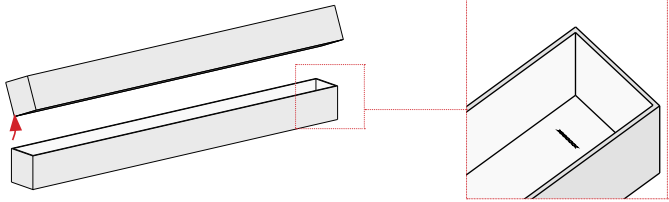







REF	PICTURE		QTY
L1		 <small>188X28-2316</small>	6



There is a Product Tracking Number in the inner side of the carton(see below diagram). For better and efficient after-sales in the future, when tear down the carton box, please take a photo of the Tracking Number and save the photo.





Parts List-3.6M

1/4

REF	PICTURE		QTY
K1		 32X40-1655	2
K2		 32X40-2323	1
K4		 40X60-1700	1
K5		 40X60-1700	1
K6		 34X50-2323	1
K7		 6X50-2323	1



REF	PICTURE		QTY
L2		 165X28-2316	1

REF	PICTURE	QTY
S5	 4x16	20
S8	 8x100	6

REF	PICTURE	QTY
Z5	 PH2	1

Parts List-3.6M

2/4

REF	PICTURE		QTY
L1		 188X28-2316	6

3/4

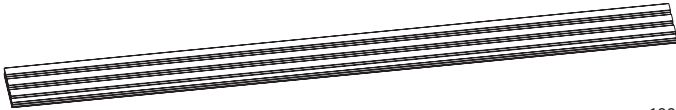
REF	PICTURE		QTY
L1		 188X28-2316	6

4/4

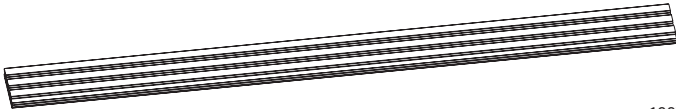



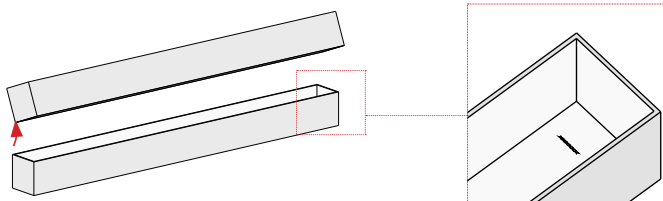







REF	PICTURE		QTY
L1		 188X28-2316	6



There is a Product Tracking Number in the inner side of the carton(see below diagram). For better and efficient after-sales in the future, when tear down the carton box, please take a photo of the Tracking Number and save the photo.



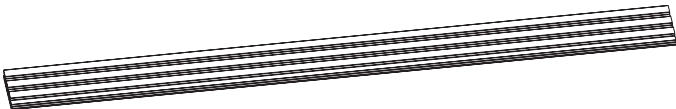

Parts List-4M

1/4

REF	PICTURE		QTY
K1		 32X40-1808	2
K2		 32X40-2323	1
K4		 40X60-1853	1
K5		 40X60-1853	1
K6		 34X50-2323	1
K7		 6X50-2323	1



REF	PICTURE		QTY
L1		 188X28-2316	2
L2		 115X28-2316	1

REF	PICTURE	QTY
S5	 4×16	20
S8	 8×100	6

REF	PICTURE	QTY
Z5	 PH2	1

Parts List-4M

2/4

REF	PICTURE		QTY
L1		 188X28-2316	6

3/4

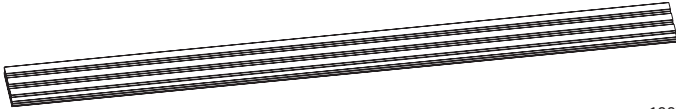
REF	PICTURE		QTY
L1		 188X28-2316	6

4/4

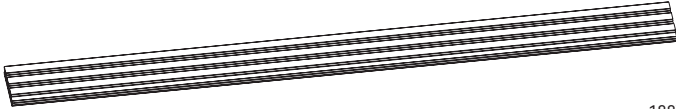
REF	PICTURE		QTY
L1		 188X28-2316	6

There is a Product Tracking Number in the inner side of the carton(see below diagram). For better and efficient after-sales in the future, when tear down the carton box, please take a photo of the Tracking Number and save the photo.

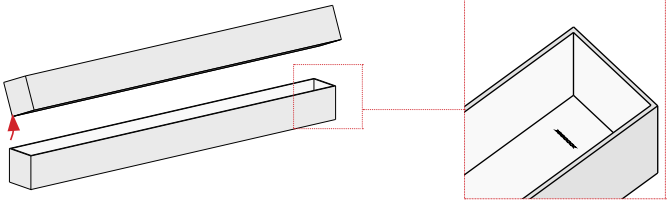

Assembly

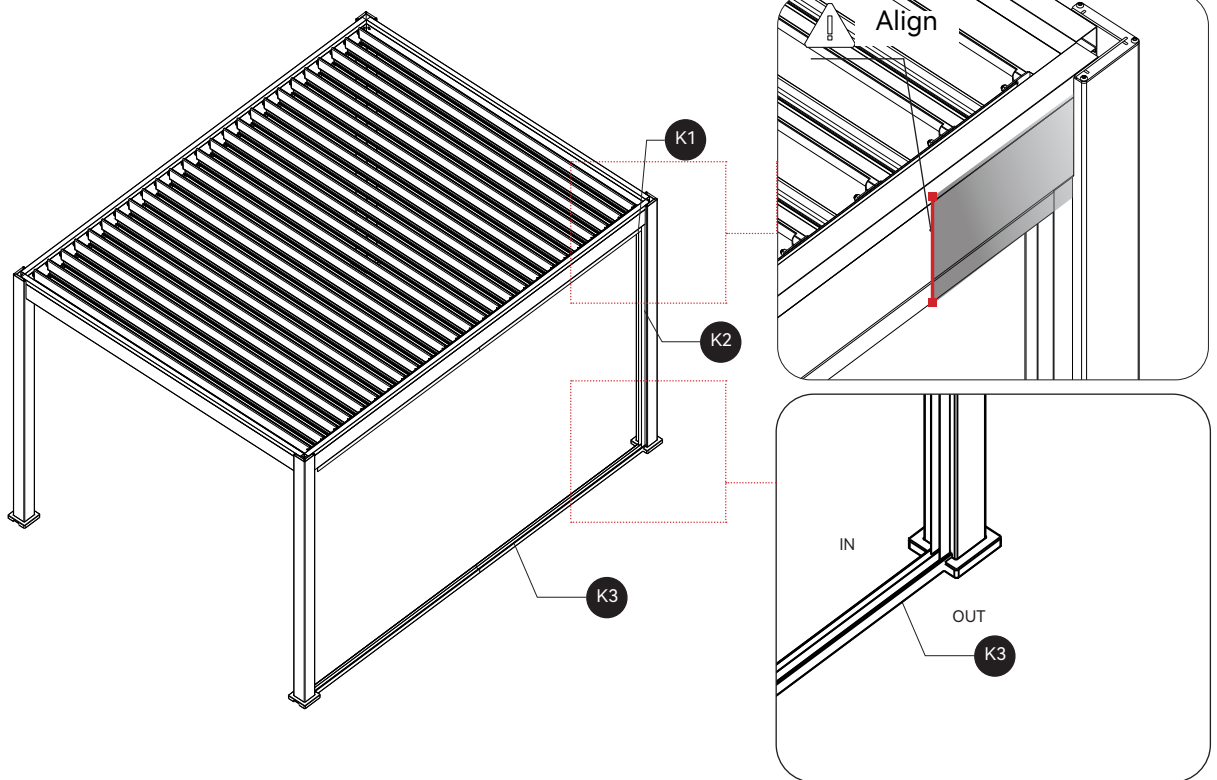
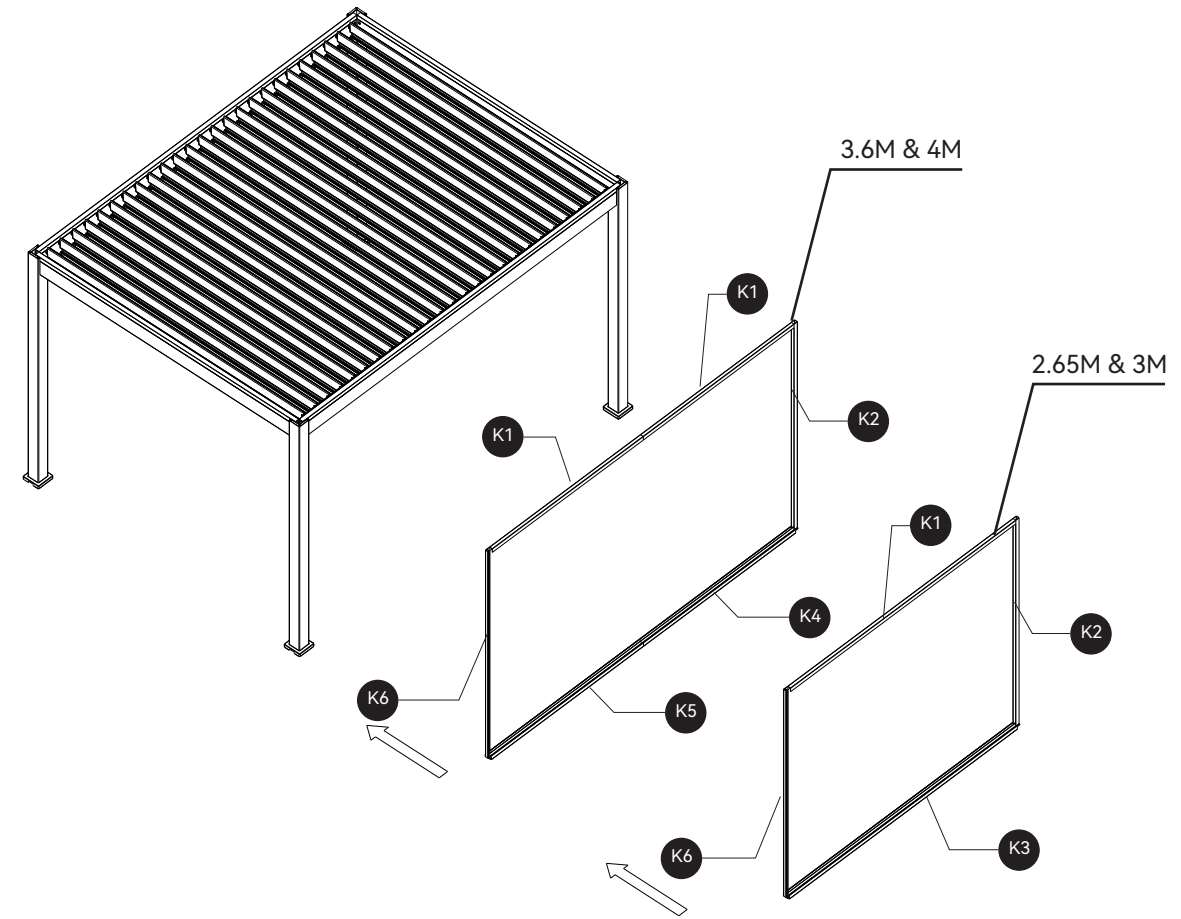

Assembly

1. Install the frame:

- a. Place **K3/K4** on the ground to assist in positioning **K2**.
- b. Position **K2** as shown in the diagram and secure it with screws.
- c. Install **K1** and **K6**, fastening them with screws.
- d. Anchor **K4** to the foundation by expansion bolts

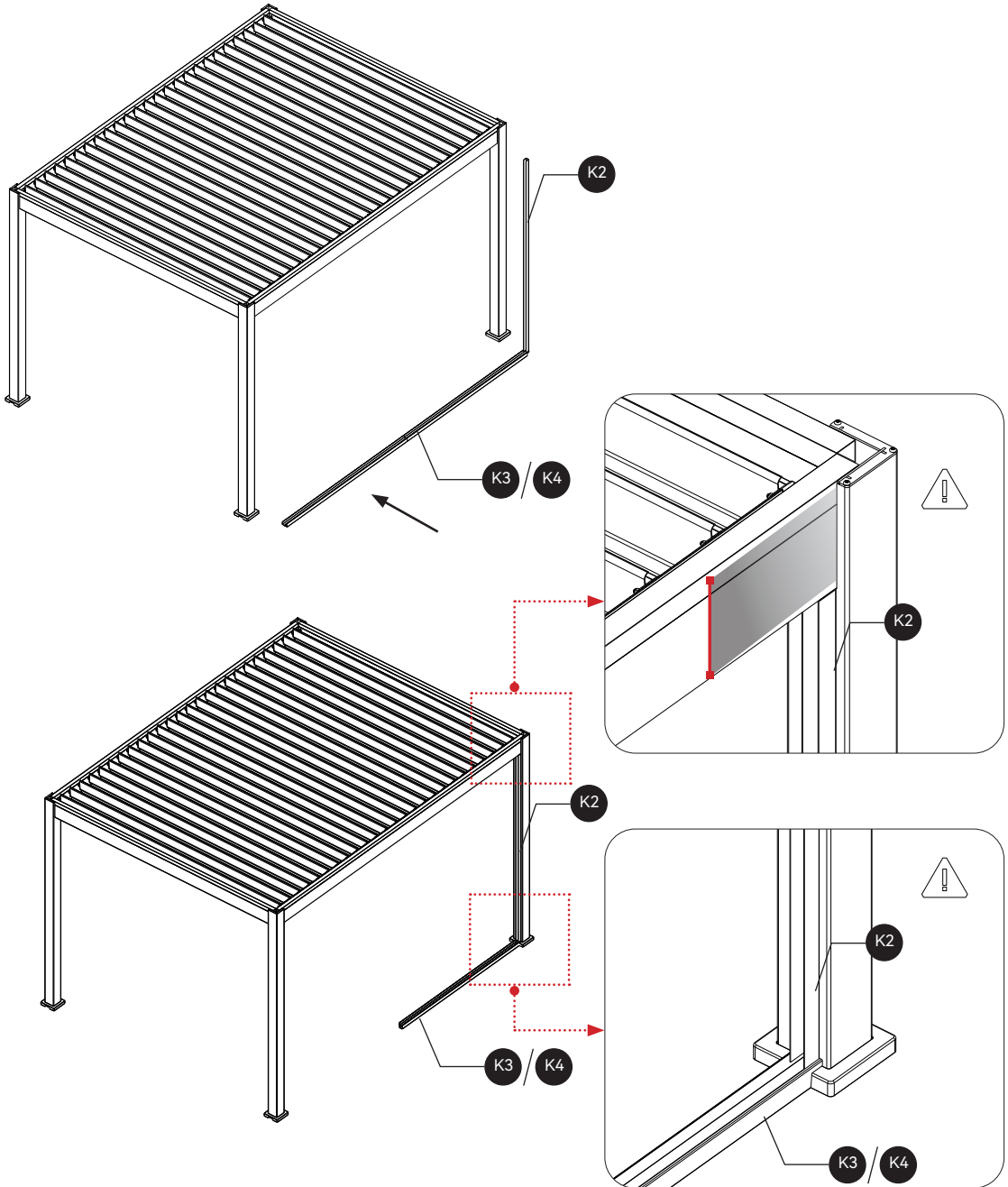

Assembly

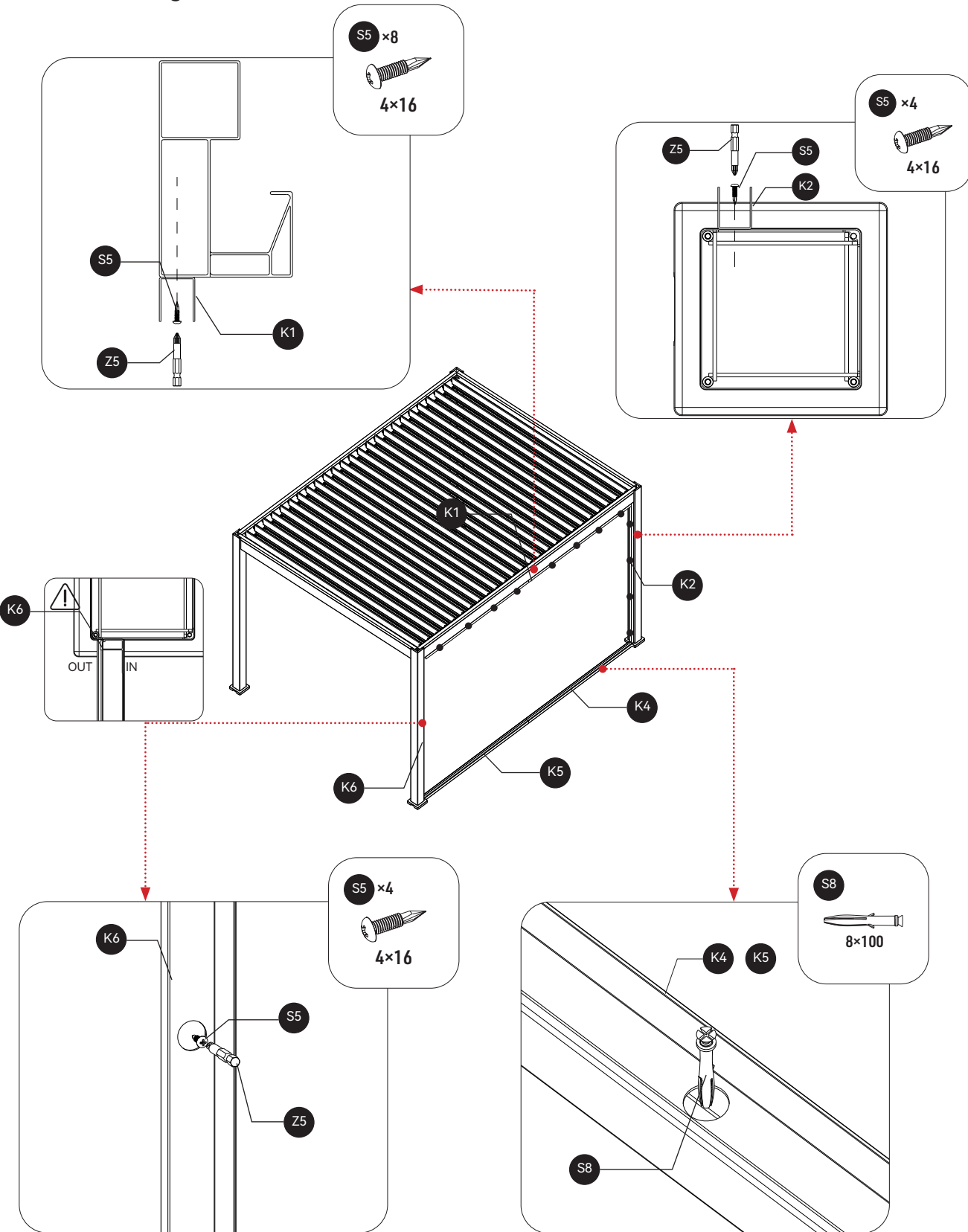

Assembly

2. install the WPC boards as shown below.

a. Insert **L1** diagonally into **K2**.

b. Install the remaining WPC boards (all **L1** type) sequentially.

c. The final board is **L2**. After the installation, cover **K6** with **K7** and secure it with screws.

Note: The boards interlock via tongue-and-groove joints.

