



3 TRANSFORMING ACCESS & INSPECTION DOOR SAFETY



PERTH
(08) 9459 8600
KALGOORLIE
(08) 9021 8300

ADELAIDE
(08) 8231 1513
NEWMAN
(08) 9175 1164

DARWIN
(08) 8963 5621
MT ISA
(07) 4743 6458

✉ sales@bendtechgroup.com.au
🌐 bendtechgroup.com.au

2-10 Kewdale Road, Welshpool WA 6106



TRANSFORMING ACCESS & INSPECTION DOOR SAFETY**INDEX**

WORKPLACE SAFETY IS GOOD FOR BUSINESS	/// 2
WORKPLACE ACCIDENTS – THE TRUE COST	/// 3
THE NEED FOR SAFER ACCESS & INSPECTION DOORS	/// 4 - 6
THE THREE-LEVEL SAFETY SYSTEM FOR CHUTE DOORS	/// 7
TOP 8 KEY FEATURES	/// 8 - 9
ACCESS AND INSPECTION STANDARD DOORS	/// 10 - 15
ACCESS AND INSPECTION ARMOUR DOORS	/// 16
CUSTOM DOORS	/// 17
ABOUT BENT-TECH ACCESS & INSPECTION DOORS	/// 18
ABOUT BEND-TECH GROUP	/// 18



“ **WORKPLACE SAFETY**
IS GOOD FOR BUSINESS ”

Businesses that invest in better workplace safety measures mitigate the risks of workplace accidents which leads to improved profitability, staff morale and greater efficiency. Furthermore, businesses also have a legal and ethical responsibility to provide a safe place of work for all employees and contractors on site.

WORKPLACE ACCIDENTS – THE TRUE COST

SAFE WORK AUSTRALIA 2014
workplace injury and illness stand

\$60 BILLION
annually



4.8%

OF AUSTRALIA'S GDP



WEEKS

absence from work with



25%

**OF INJURED WORKERS
REQUIRING 12 OR MORE
WEEKS TO RECOVER**

A report prepared for Safe Work Australia in 2014 stated that direct and indirect costs associated with workplace injury and illness stand at more than \$60 billion annually which represented 4.8 percent of Australia's GDP at the time¹.

On average, a typical serious workers' compensation claim involves four weeks' absence from work with 25% of injured workers requiring 12 or more weeks to recover from the injury or illness².

The facts clearly show that a serious illness or injury has a major impact on the individual affected, the organisation that employed the affected individual and society.

Medical bills and other direct expenses come at a great cost to the individual, the employer and the state.

Indirect costs such as reduced productivity and increased labour costs lead to reduced business profitability. This directly impacts the bottom line.

It's therefore to everyone's advantage to invest in workplace safety measures as it benefits all parties being the employer, the employee, the community and the state.

THE NEED FOR SAFER ACCESS & INSPECTION DOORS

The hazards associated with the use of access and inspection chute doors at mine sites, manufacturing plants and other operations have been an ongoing concern for some time.

Well-documented incidents have caused staff injury and/or death, production outages and, in some cases, significant periods of plant shut down.

WHAT ARE CONVEYOR CHUTE DOORS OR ACCESS HATCHES?

In the mining and manufacturing industries, conveyor chutes need regular inspection and maintenance to ensure these critical components of a working plant run as efficiently as possible.

Access and inspection chute doors provide maintenance workers with access to conveyor chutes so that they're able to carry out maintenance activities such as general inspection and cleaning.

These access chute doors are generally a simple access hatch with a single level of protection i.e. the door itself.

CHUTE DOORS NEED TO MEET SAFETY STANDARDS

Chute doors need to meet AS1755 conveyor safety requirements³ and AS4024 machine and equipment safety requirements⁴. However, chute doors have been known to be the cause of various hazards which have resulted in serious workplace injuries.

Single access chute doors offer no protection when workers open them to conduct their routine maintenance activities. Workers who reach their arms or torsos into chutes are at risk from being struck by unexpected falling debris.

While some attempts have been made to make chute doors safer by introducing mesh to prevent entering the chute, this 'safety' mesh struggles to withstand the high impact of the material flow and degradation of the mesh also creates dangerous nip points. Nip hazards can cause instantaneous amputation and entrapment so the seriousness of this danger cannot be underestimated.

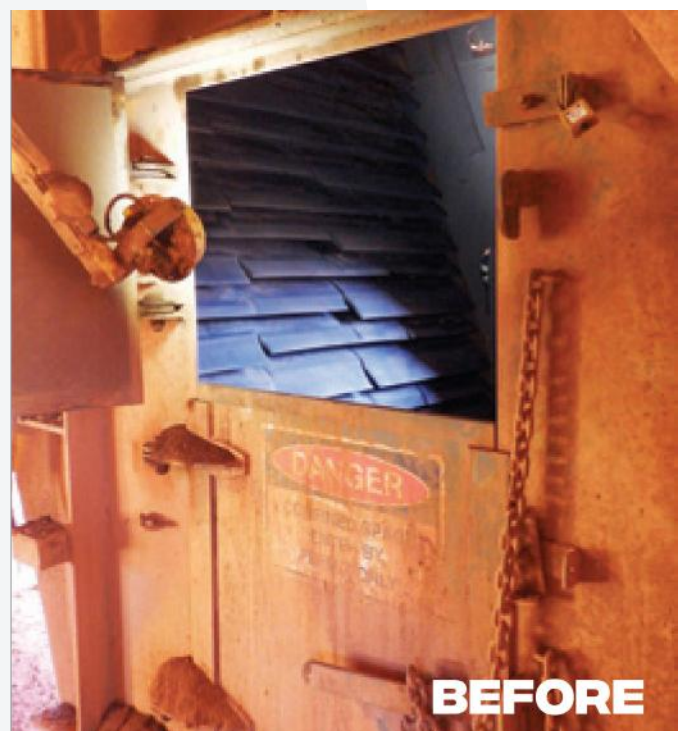



AFTER

SAFETY INCIDENTS WHERE CHUTE DOORS WERE INVOLVED

In a recent case, a contract employee had entered a chute and was working in an ore transfer chute when the conveyor which he was standing on was started.

The conveyor started to move and the employee was assisted from the chute by another person. In another case, a person was using a 6,000psi high pressure water blasting lance to clear ore build up inside a chute. As the operator stopped blasting to reposition, the drop in thrust from the water lance caused the operator to move forward contacting the safety bar.

The safety rail support bracket failed resulting in the operator falling head first into the chute. As the operator fell forward into the chute, he was able to spin his body and grab at the chute door bottom ledge with his right hand, preventing a potential fall of a further seven to eight metres onto a running conveyor.

His colleague, who was operating the dead man safety control valve approximately six metres from the chute, was able to recover his colleague.

There are also potential substantial regulatory fines associated with incidents. Companies have faced severe fines in the past for safety lapsed with regard to chute doors. For example, in Manchester, England, the court fined a company 120,000 GBP when a man fell down a chute into a paper pulping machine⁵.

CHUTE DOOR ISSUES ALSO HAVE AN IMPACT ON PRODUCTION OUTPUTS

Over and above limited safety, single-level chute doors also have detrimental operational and financial impacts such as halting plant production to open a door to clean the chute. For example, coal wash plants frequently experience blocked chutes due to the clay found in coal.

This can occur up to six times per night in a plant that has capacity to wash 1200 tonnes per hour. To clear the blockage a chute door needs to be opened and the blockage hosed with high pressure water until it is gone.

This process can take up to two hours, effectively taking the plant offline for the duration of the cleaning process.

STANDARD CHUTE DOORS CAN ONLY BE OPENED WITH A SPECIAL TOOL AND NOT BY HAND

The AS 1402 safety standard for Conveyor Guarding requires that doors can only be opened by use of a mechanical tool, and not by hand. Some organisations have looked at using a bolt to lock each door which would then require a spanner or specialised tool to open the chute door.

This too can be a time-consuming process as the correct tool might not be on hand or the bolt cannot be removed or replaced efficiently as it may have warped or rusted due to the harsh elements that it is exposed to.

Any loss of production time, even an unplanned 10 minutes, affects the bottom line of the business detrimentally.

THE THREE-LEVEL SAFETY SYSTEM FOR CHUTE DOORS

A three-level safety access system protects staff and keeps operations up and running. This system consists of three parts: the outer door, the second door and a cross bar protection system on the inside of the doors to prevent the door from being opened without a tool.

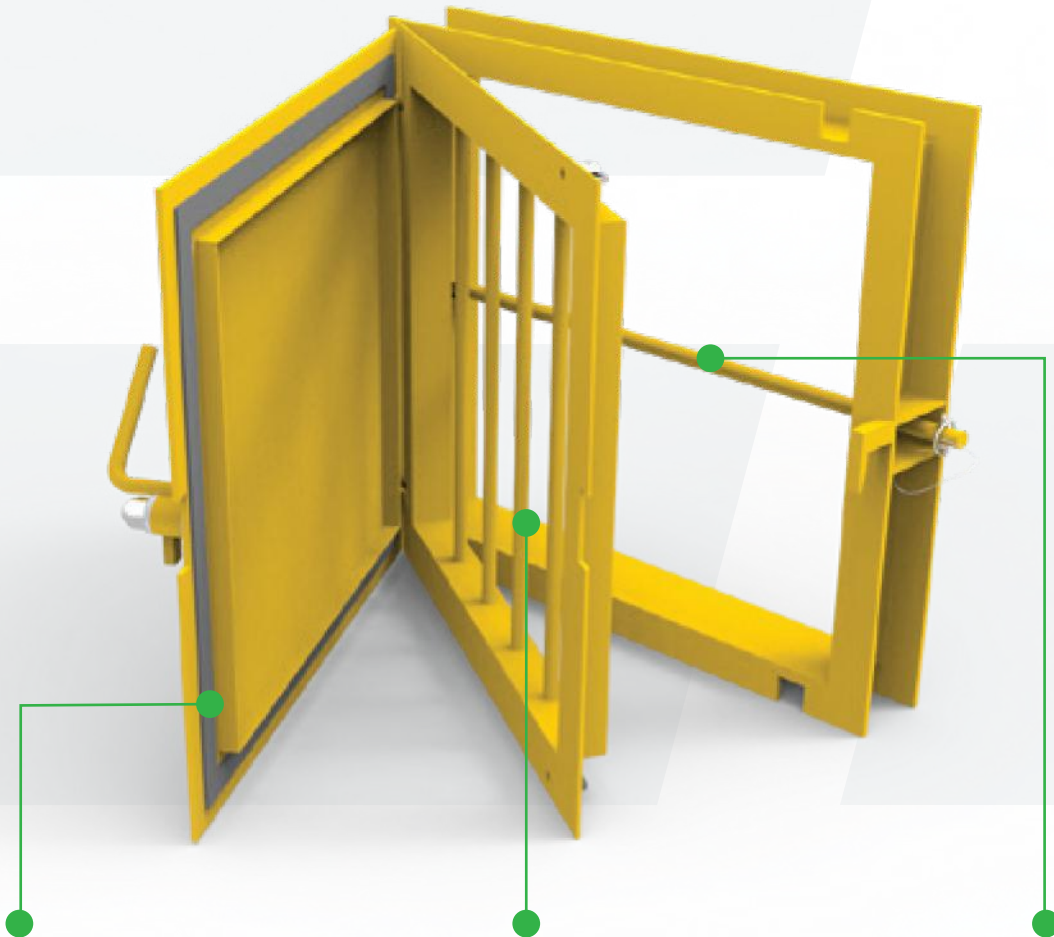

1st level of safety

The inside of the outer door is fitted with a rubber seal to reduce noise, vibration and dust from escaping the chute. When an operator opens this outer door, the operator is able to view the internal mechanisms of the chute but cannot access the chute due to the second door.

2nd level of safety

The second door is similar to a jail bar door which gives operators the ability to view the areas of hazard or concern without allowing them the ability to access the chute. A fixed bolt system included for additional protection and to prevent the door from being opened without a tool. The operator could now perform routine inspection or maintenance tasks without the risk associated with having free access to the chute when no second door is fitted.

3rd level of safety

The third level of protection is a crossbar protection system on the inside of the doors, to prevent any personnel accessing the chute. This final failsafe mechanism is the last line of a very good defence against workplace accidents involving chute doors.

TOP 8 KEY FEATURES

TO LOOK OUT FOR YOUR INSPECTION DOORS

Routine maintenance of conveyor chutes is required for almost all conveyor systems. These doors assist staff in obtaining access to the conveyor chute for this purpose.

Since the door is a required element replacing standard chute doors with a safety oriented product will help create a safer plant that is easier to service and maintain.

Safety-oriented inspection doors should contain the following 8 features.



1. FULL ACCESS FOR SERVICE AND MAINTENANCE

The inspection door must be fit for purpose and contain safeguards to ensure potential risks are mitigated and operations can continue. Inspection doors should therefore have the necessary dimensions for unencumbered chute access to ensure maintenance needed on a chute can be performed.

However, this access must come with the necessary safeguards to ensure that the risk of falling into the chute or being struck by debris from the chute are mitigated.

Thick metal which can withstand direct and high impact from material flow. Conveyor chutes generally contain material which is travelling at a high velocity and due to its composition may be dangerous to human operators. The inspection door fitted to a conveyor chute should therefore be constructed from thick metal which can withstand the impact from high material flow over a long period of time.



2. MODULAR DESIGN TO ENSURE EASE OF REPLACEMENT

The chute inspection door must have a modular design so that it can be easily removed and replaced with a new one. This replacement can take place by either welding or bolting a new door in place without any need to modify the chute cavity in any way. The modular design must also ensure that any replacement can be fitted without compromising the sanctity of the seal to ensure no dust or debris can escape the chute.



3. HANDLE TEMPERATURE EXTREMES

Chute inspection doors must be able to withstand extreme temperatures both from within the chute itself and from external weather conditions. The door should not warp or compromise its seal in any way to ensure no dust or debris can escape and the door can be opened and closed.



4. HEAVY DUTY LOCK AND HINGES

Locks and hinges are generally the weakest spots on any door. On chute inspection doors, it is imperative that these traditional weak spots also withstand temperature extremes and the high impact of material flows from within the chute. Locks and hinges should not decay over time and should always be able to perform their function without extra intervention from chute door operators. The operator must be able to open the outer door at any time as the operator may need to attend to a time critical emergency or maintenance task.



5. CUSTOMISABLE TO ENSURE THEY CAN MEET THE NEEDS OF A SITE

Chute inspection doors must be customisable to meet the needs of any site. Due to the many industries which utilise conveyor chutes for many different purposes, the chute inspection door must be made to fit a wide variety of chute configurations. Safety should never be compromised as a result of a safety product not being able to fit a specific configuration.



6. NOT RELIANT ON SPECIAL TOOLS TO OPEN THE OUTER DOOR

Operators must be able to open outer doors by hand without any hindrance. Chute inspection doors should not rely on any special tools to open the outer door. As with the requirements for locks and hinges, chute operators may need to attend to a time critical emergency or maintenance procedure and should therefore be able to open the door without the need for a special tool or spanner. Should a tool be required to open the door it may be missing at the time it is needed most. If special bolts are used to lock the door they may contain rust or a similar substance which would prevent the door from being opened in a timely fashion.



7. MEET AUSTRALIAN ENGINEERING CERTIFICATION STANDARDS

Chute inspection doors must meet the AS1755 conveyor safety requirements, the AS4024 machine and equipment safety requirements and the AS 1402 safety standard for conveyor guarding. To ensure organisations meet compliance requirements, chute inspection doors that are in use must meet these safety standards. Failure to fit a chute door that meets these standards could lead to serious liability for an organisation should they fail a safety inspection or if a serious accident occurs because of the use of non-compliant safety equipment.



8. IN STOCK AND READILY AVAILABLE

Finally, the chute inspection door chosen by an organisation must be one that is freely available and in stock. This availability is needed to ensure a speedy replacement can be fitted should the need arise to limit delays a shutdown of the machinery will create.

ACCESS & INSPECTION STANDARD DOORS

Bend-tech's Access and Inspection Door is used for providing safe and efficient viewing and access to chutes, hoppers and other areas of confined space or working at heights hazards.

CONSTRUCTION

- 3-way safety system – the inside of the first door is fitted with a rubber lining for noise and vibration reduction. The second door, which is the jail bar door, gives you the ability to view but not access. A dual lock safety system is included at the top and bottom for additional protection. Inside the door frame is a cross bar protection system which is the third and final safety mechanism to prevent any personnel accessing the chute.
- Heavy duty lock and hinges, as well as a thick metal door for impact protection. Hinges are nylon insulated to prevent bind up.



**JAIL BAR DOOR
450MM X 450MM**
Part No. 5000045



**JAIL BAR DOOR
600MM X 600MM**
Part No. 5000040

ACCESS & INSPECTION STANDARD DOORS



**JAIL BAR DOOR
750MM X 750MM**
Part No. 5000108



**JAIL BAR DOUBLE DOOR
TOP 1000MM X 450MM**
Part No. 5000107



**JAIL BAR DOUBLE DOOR
1000MM X 750MM**
Part No. 5000114



**JAIL BAR DOOR
1200MM X 600MM**
Part No. 5000109

ACCESS & INSPECTION STANDARD DOORS



**JAIL BAR DOUBLE DOOR
2000MM X 820MM**
Part No. 5001695

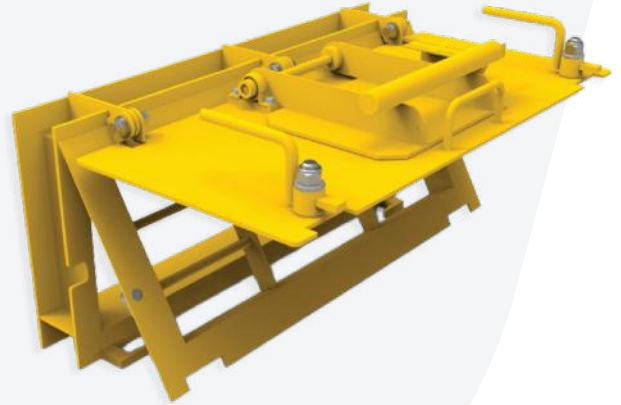

**JAIL BAR ACCESS DOOR
900MM X 410MM**
Part No. 5502522

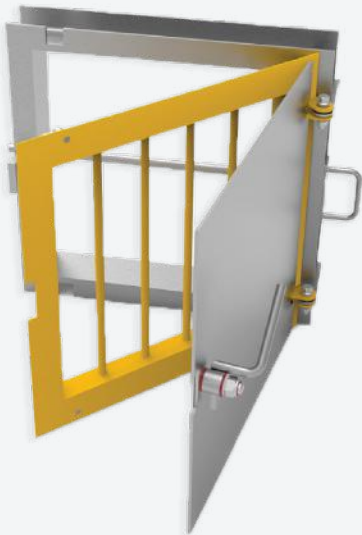

**JAIL BAR DOOR GALVANISED
600MM X 600MM**
Part No. 5000181

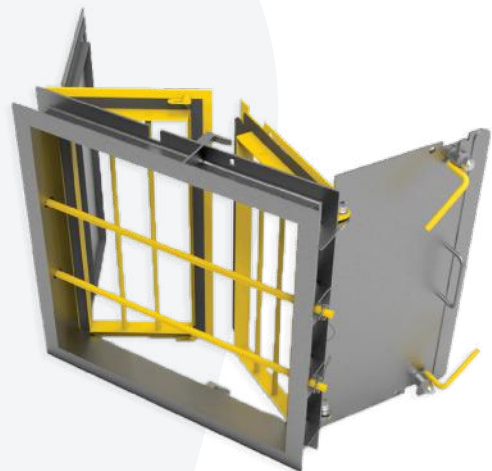

**JAIL BAR DOOR GALVANISED
DOUBLE DOOR 750MM X 750MM**
Part No. 5000182

ACCESS & INSPECTION STANDARD DOORS



**MESH MACHINE GUARDING
DOOR 950MM X 600MM**
Part No. 5001844



**ACCESS & INSPECTION
HATCH DOOR 750MM X
750MM**
Part No. 5501646

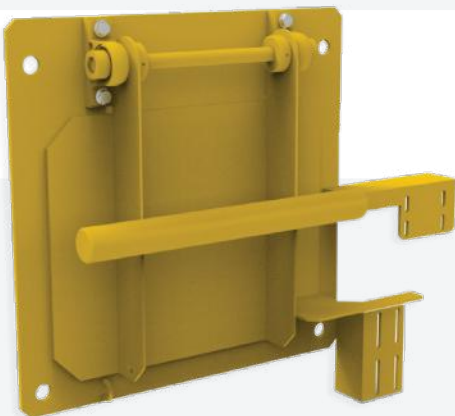

**BLOCKED CHUTE
DETECTORS TYPE 1**
Part No. 5000112

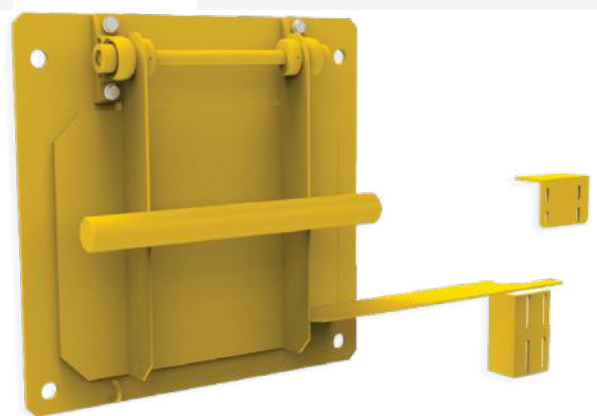

**BLOCKED CHUTE
DETECTORS TYPE 2**
Part No. 5000113

**ACCESS & INSPECTION
STANDARD DOORS**



PREMIUM JAIL BAR DOOR
Part No. 5501819

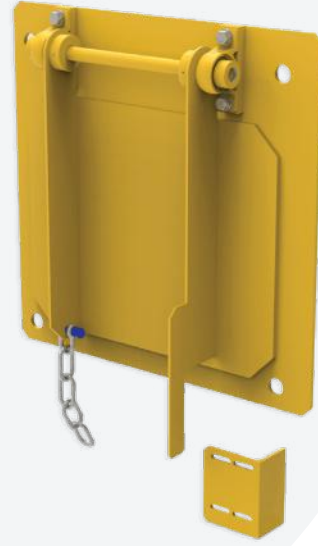

BLOCKED CHUTE DETECTORS
Part No. 5501664

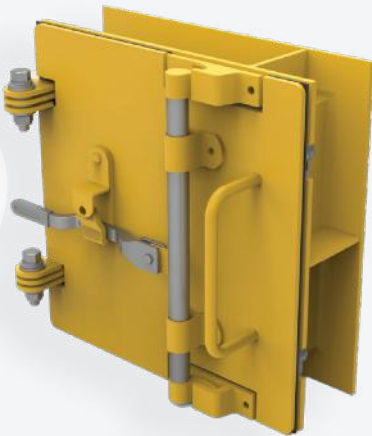

**ACCESS DOOR WITH
CONTAINER LOCK
250MM X 250MM**
Part No. 5503442



**ACCESS DOOR WITH
CONTAINER LOCK
350MM X 350MM**
Part No. 5503443

ACCESS & INSPECTION **STANDARD DOORS**



**ACCESS DOOR WITH
CONTAINER LOCK**
450MM X 650MM
Part No. 5503444



**ACCESS DOOR WITH
CONTAINER LOCK**
700MM X 850MM
Part No. 5503445

ACCESS & INSPECTION ARMOUR DOORS

HIGH IMPACT AND WEAR AREAS

Iron ore chutes are one of the harshest environments on-site. The speed, weight and abrasiveness of the substrate can create extensive damage, leading to replacement of the door. High impact and abrasion caused by production can require the door to be fitted with added protection.

Failure to employ the correct door will result in destruction, creating a potentially dangerous situation and necessary replacement, leading to further costs and loss of productivity.

BEND-TECH'S SOLUTION

Bend-tech's solution is known as the Armour Door, built to withstand high flow and high wear situations. The Armour Door is available in a number of configurations, including bolt-on chocky bars which sit proud of the secondary 'jail bar' door protecting them from damage and wear. Other options for the doors include Hardox and Bisalloy, the doors can also cater for a wear liner of choice.

The chocky bars are a fantastic replaceable option, which provides ongoing protection for the door. They can be monitored and replaced as needed, simply unbolt the old worn out bars and replace with new ones.



**ARMOUR DOOR HIGH
IMPACT & ABRASION DOORS**
Part No. 5501553



**HEAVY DUTY IMPACT
DOOR**
Part No. 5001754

CUSTOM DOORS

CUSTOM DOOR SIZES

We design, engineer and construct doors to fit any size your access or inspection point requires. You can provide us with the dimensions or we can come and visit and measure up on-site. Our doors' safety and performance characteristics are not limited by size, we ensure full compliance no matter how big or small the entry or access point.

LOCKING MECHANISMS AND HANDLES

Many sites require specific locking and opening mechanisms to meet compliance. When designing, engineering and constructing your door we install the hardware that your site requires; locking mechanisms, lock open capabilities and handle types are just some of the features we can fit to your access and inspection door. If there is something specific you require, we will incorporate the feature for your site.

SURROUNDS AND STRUCTURAL REQUIREMENTS

When it comes to door installation, we make it easy for you. If surrounds need replacing or beam work needs to be catered for, we can provide a solution. Incorporating the construction of a custom surround ensures ease of installation. Adaptability is one of the many things that separates our doors from the rest.

SECONDARY DOOR OPTIONS

The secondary level of our access and inspection doors also allow for custom options depending on your requirements. There is the more traditional 'jail bar door' and there is also our mesh option. We design and construct the door to provide the safeguard your operators inspecting the area require.

SENSORS AND SPRAYERS

We can accommodate any sensors or sprayers that your access or inspection point may require. Trip sensors indicating a blocked chute can be moved and attached to the doors. This ensures the chute doesn't fill past the access point, allowing for easier inspection and safer operations.

ABOUT BEND-TECH ACCESS & INSPECTION DOORS

Bend-tech access and inspection doors are manufactured out of high performance materials to deliver high performance outcomes. Heavy duty steel engineered and constructed for full certification ensures Bend-tech doors stand up to the harshest environments.

Premium features such as nylon hinge washers and insulation, heavy duty rubber seals, handles and locking mechanisms as well as a range of application specific finishes such as hot dip galvanising and powder coating ensures outstanding operation throughout the door's lifespan.

Intelligent consultation and design will ensure the correct door is supplied depending on site requirements. Application specific innovations and features are incorporated to ensure a long-lasting high-performance access and inspection door is installed, providing the promised benefits for longer.

ABOUT BEND-TECH GROUP

We deliver sustained value by providing cutting edge solutions through collaboration and innovation. For more than 30 years we have delivered intelligent design and custom-certified products and services to the Mining, Fabrication, Marine and Oil and Gas industries across Australia and around the world. We have achieved this through a deep understanding of our customers and their requirements as well as innovative and industry leading design, engineering and construction.

“ **MAKING MAINTENANCE
ON-SITE SAFE, EFFICIENT
AND EASY** ”

