

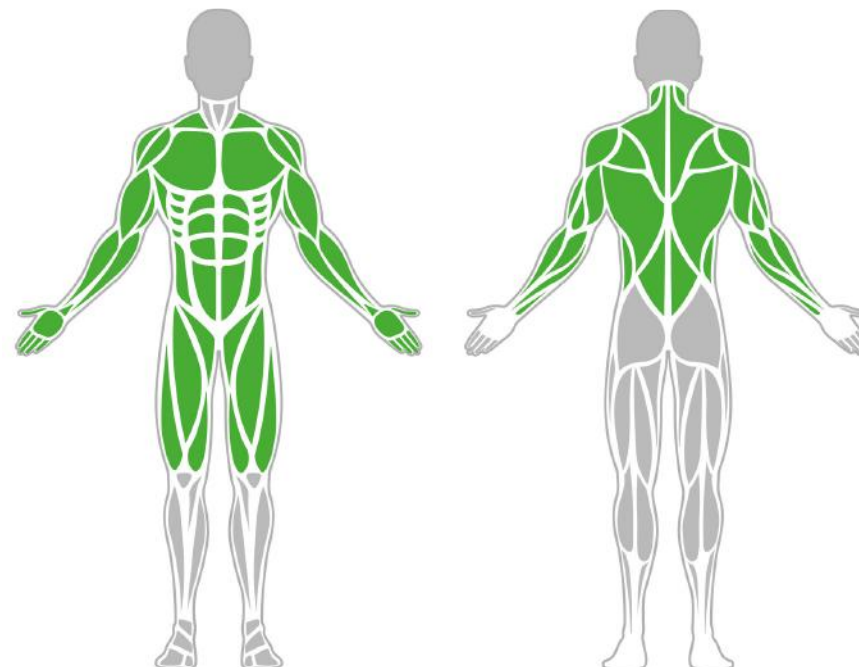

Muscle Groups Focus



Narrow Pull-Up Bar 1500

The narrow pull-up bar is an excellent tool for performing pull-up exercises, which are the basic exercises of bodyweight training. The heavy grip pull-ups performed on the equipment provide an intense workout for the arm, shoulder, abdominal, and back muscles.

Attributes

Product code	1-1-047
Certificate	EN 16630, ASTM F3101
Age group	14 + years
Capacity	1 person
Max. weight load	218.26 lbs
Type	Calisthenics
Difficulty level	Hard

Side View

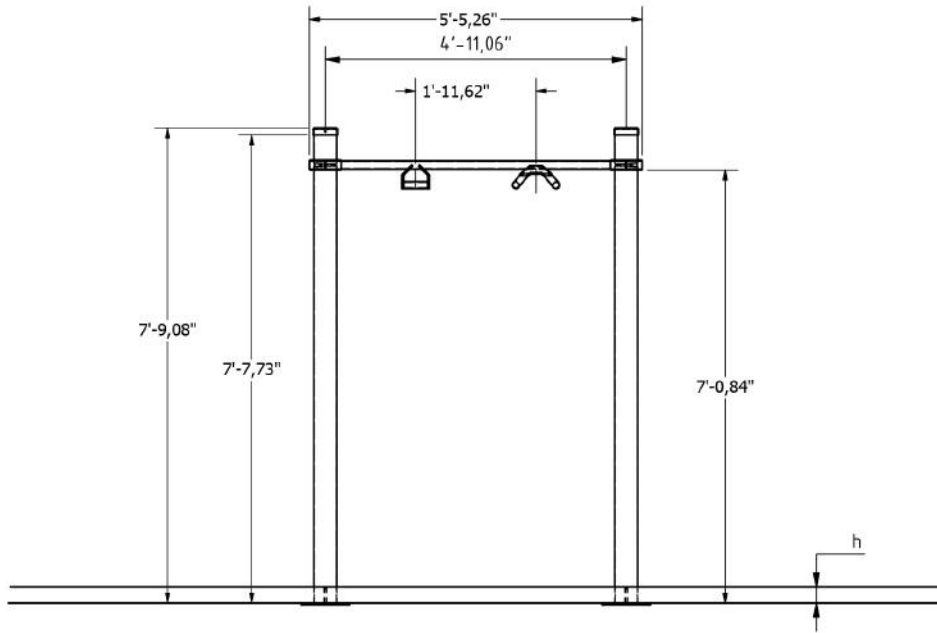

Plan View

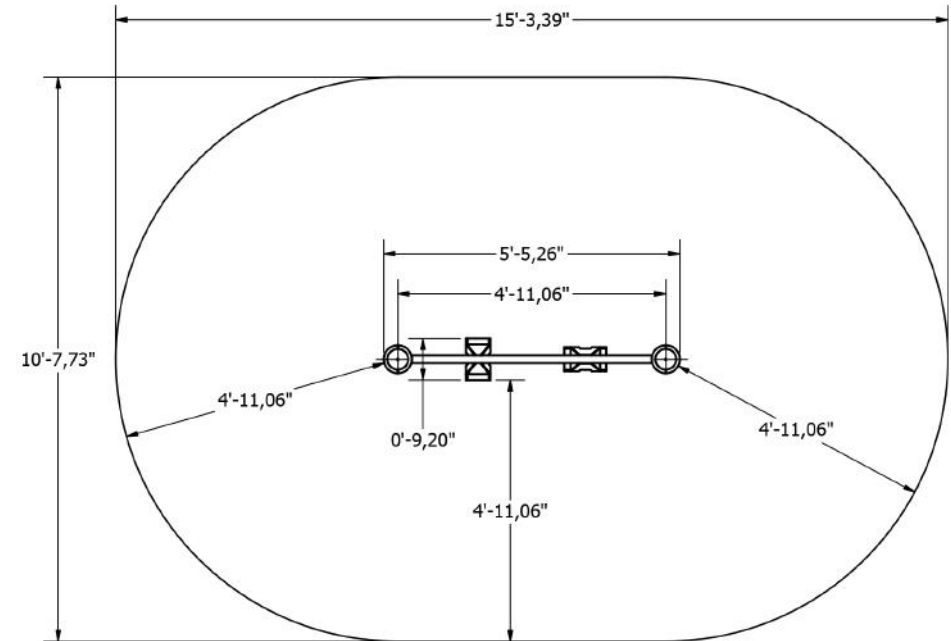

Installation information

Number of installers (concrete)	At least 2 people
Total installation time (concrete)	45-90 min.
Number of installers (equipment)	At least 2 people
Total installation time (equipment)	20-30 min.
Excavation volume	14,13 ft ³
Concrete volume	14,13 ft ³
Size of the base structure	2pc 19.69 x 19.69 x 31.5 „
Anchoring options	In-ground or surface
In combined structures, the volume of concrete required varies.	

Technical specification

Safety surface area	Around 4.92 ft radius
Net weight	35.27 lbs
Material	S235
Critic fall height	43.31"
Color options	
For more color options, discuss with your sales representative.	

Warranty

Structure	25 years
Steel	15 years
Paint	2 years
Plastic	5-10 years
Rubber	1-3 years
Moving parts	2 years
Detailed information in the warranty document	

Material specification

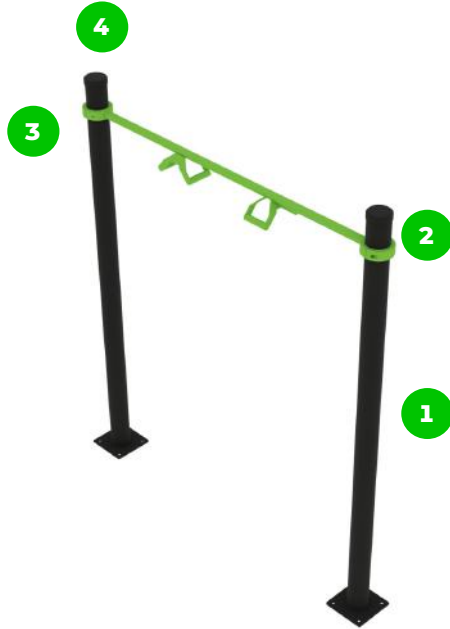

The element is made of high quality S235 steel, which has been cleaned via sandblasting. A corrosion resistant powder coating finish is then applied. Also available with galvanized surface for even greater protection and longevity!



The clamp system allows for easy assembly and extreme stability.



The connecting elements are fastened with vandal-proof stainless steel screws and nuts.



The ends of the bars and posts are sealed with injection-moulded plastic caps.

BESTSTRONG

 [beststrongworld](#)  [beststrongworld](#)  [usa.beststrong.com](#)  [usa@beststrong.com](#)

