

CEIT
by GJRECO

Multiway



NEW F2000AS

Compact yet powerful

Adopt to extremely narrow aisles

NEW F2000AS

X20S: Robust Pallet Handler with High Load Capacity. The X20S is engineered for high-efficiency pallet handling, offering a rated load capacity of up to 2,000 kg and a lifting height of 210 mm. Ideal for automatic transfer and handling of goods on both two-way and four-way entry pallets across multiple storage locations.

With its high-speed driving capability of 1.3 m/s and strong climbing ability, it can easily navigate a wide variety of environments. Additionally, the **SLAM navigation system ensures positioning precision of ± 10 mm, while Wi-Fi/5G communication enables seamless real-time data exchange.**



● Compact

Light weighted for ground-bearing requirement
Adopt to extremely narrow aisles

● Direction of drive

Forward, backward,
on the spot rotation

● Lift

Up to 210 mm
Safe and precise lifting to elevated
storage or production areas

● Integration with Twiserion & VDA 5050

Fully compatible with the VDA 5050 communication standard, ensuring seamless integration into mixed fleets

● Safety

Bottom obstacle avoidance LiDAR
3D safety curtain
Fork head anti-collision
Safety bumper
Sound and light alarms
Emergency stop button

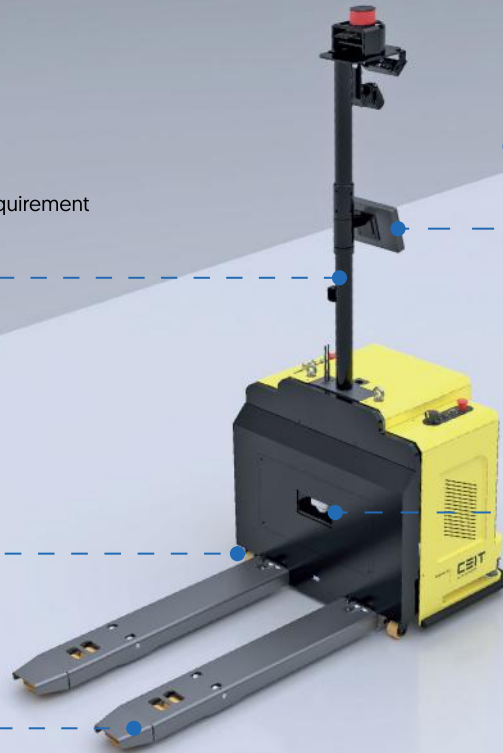

Lifting mechanism

LIFTING HEIGHT UP TO 210 MM

Navigation

LiDAR, Sky navigation,
Mixed navigation

Safety

OBSTACLE AVOIDANCE
3D SAFETY CURTAIN

Max speed

1.3 M/S

Rated load

2,000 KG

Charging

AUTOMATIC - CONTACT

Navigation & connectivity



With **SLAM navigation**, it builds and updates maps in real time, ensuring smooth operation in dynamic environments. Positioning precision of ± 10 mm minimizes errors, while Wi-Fi/5G connectivity integrates it into fleet systems. Real-time monitoring makes pallet transport accurate, connected, and reliable.

Productivity & uptime



The X20S is built for non-stop performance. Automatic charging keeps downtime minimal, while its climbing ability and 1.3 m/s speed ensure smooth flows. High endurance and maneuverability make it the backbone of warehouses that **need maximum efficiency**.

Flexibility & integration



Its design allows quick implementation without complex adjustments to existing infrastructure. Operators gain a reliable partner that blends seamlessly into workflows, reduces manual strain, and improves workplace safety. With smooth integration into digital management systems, **the X20S supports smarter decision-making and a more resilient supply chain**.



High load capacity

Fast operation

Advanced safety

Exceptional maneuverability

Integration with Twiserion & VDA 5050

Automatic charging



F2000AS

SPECIFICATION

Type	Forklift with counterbalance
Navigation	LiDAR, sky navigation, mixed navigation
Direction of drive	Forward, backward, on the spot rotation
Minimal turning radius (m)	1.6
Max speed (m/s)	1.3
Load capacity (kg)	2,000
Lift	Electric
Max lift (mm)	210
Dimensions [L, W, H in mm]	1,844x844x(1,940/2,140/2,340)
Batteries	Lithium
Charging	Automatic - contact
Control	Automatic/manual control
Safety	Bottom obstacle avoidance LiDAR, 3D safety curtain, fork head anti-collision

Twiserion Fleet Manager

Asseco CEIT AGVs are controlled by their own monitor & control system **with VDA 5050 standard** for guiding and monitoring logistics equipment in real time.

Twiserion Fleet Manager provides comprehensive fleet management, as well as the fleet's real-time monitoring and display of the current status and the performed request. Thanks to the collected statistical data, the customer can easily identify problem areas and focus on their optimization. **The software is also suitable for various AGV manufacturers thanks to VDA 5050 compatibility.**



asseco-ceit.com

E-mail: sales@asseco-ceit.com

