

**CEIT**  
by GSECO



# NEW **U800AR**

**Versatile under-run AGV focused  
on e-commerce and pharmaceuticals**

# NEW U800AR

The **U800AR** is a low-lift under-run AGV designed to optimize logistics processes across various industrial sectors, primarily in applications such as **E-COMMERCE, RETAIL, PHARMACEUTICALS, COSMETICS AND APPAREL INDUSTRIES.**

The U800AR is engineered to enhance warehouse operations by improving inventory management and maximizing space utilization. It features a modular design that ensures **STABILITY, RELIABILITY, AND EASY MAINTENANCE.** With a temperature resistance ranging from **-20°C to +50°C**, it is suitable for deployment in challenging industrial environments. Advanced safety features, including collision protection, fire-resistant materials, and audio-visual alarms, ensure safe operation even under high-load conditions.

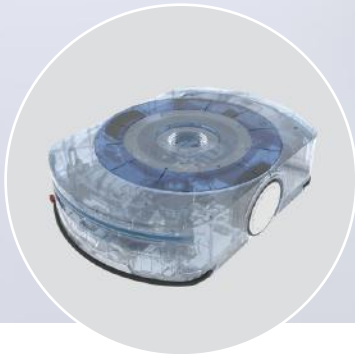

## ● Modularity

The first platform-based robot series in the industry  
Stable, reliable and easy to maintain

## ● Multiple environments

Adaptation to various ground conditions and wide temperature design

## ● Flexible extension

Supporting various assemblies such as robotic arms, rollers and pallet tooling

## ● Safety

Obstacle avoidance  
Fire-resistant materials  
Sound and light alarms  
Safety bumper  
Emergency stop button

## ● Direction of drive

Forward, backward, on the spot rotation

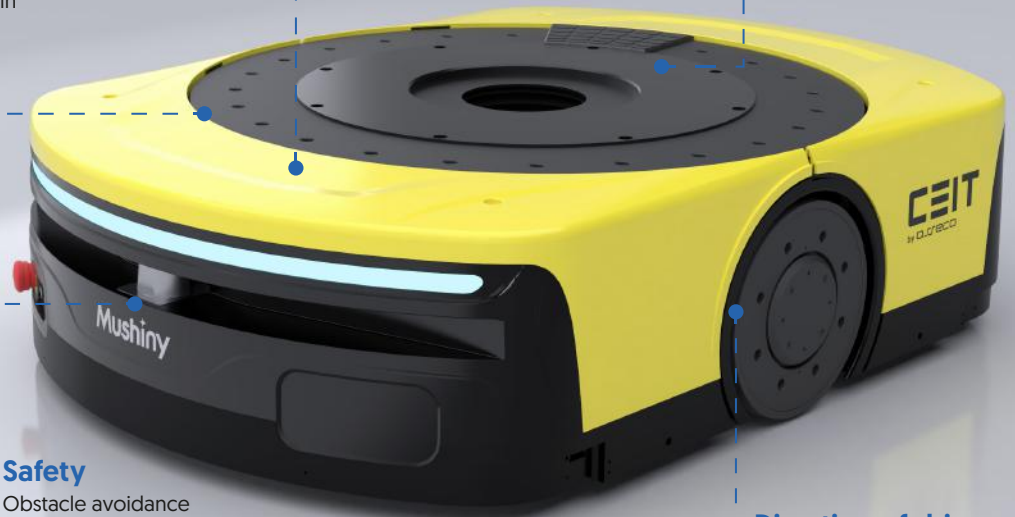

## Lifting mechanism

ELECTRIC  
LIFTING HEIGHT UP TO 60 MM

## Navigation

2D CODE

## Safety

TRAFFIC CONTROL,  
LIDAR OBSTACLE AVOIDANCE

## Max speed

2.2 M/S

## Rated load

800 KG

## Charging

AUTOMATIC

## POD lifting scenario



### E-commerce cosmetics company

Robots can easily help cross-border beauty e-commercial company complete order picking based on real-time data updates from the system, with an average picking efficiency of over 2,000 pieces/h for B2B orders.



### Pharmaceutical cold chain

Total cold storage inventory: 10,000+, SKU type: 100+; here AGV robots are used to lift PODs; conveyers are used for inbound and outbound process in warehouse; operating across temperature zones (cold storage area temperature as low as -20°C); greatly reduce the difficulty of manual work and improve the overall efficiency.

## Pallet lifting scenario



### Highly automated project

In the highly automated logistics conveying project, robots reduce the work intensity of operators and increase the work capacity by 45%, realizing the automatic handling of smart factories.



### Military enterprise

The customer's system assigns tasks, and intelligent robots realize automatic handling and warehousing, connecting the upstream and downstream links to form a continuous, balanced and well-paced logistics operations based on tasks.

## Roller transferring scenario



### Precision manufacturer

Double roller robots are mainly used for materials handling in the intelligent manufacturing line, which improves the entire intelligent system



### Top electronic manufacturer

Single roller robots fit perfectly with the conveyor line, which not only solves the problem of the customer's shortage of man power, but also increases the warehouse capacity by three times, connects production and marketing chain, realizes accurate inventory management and intelligence.

All-aluminium  
mechanical structure

Segmented chassis

Connecting rod  
jacking structure

Wheel integrated  
planetary reducer

Integrated motor  
and servo controller

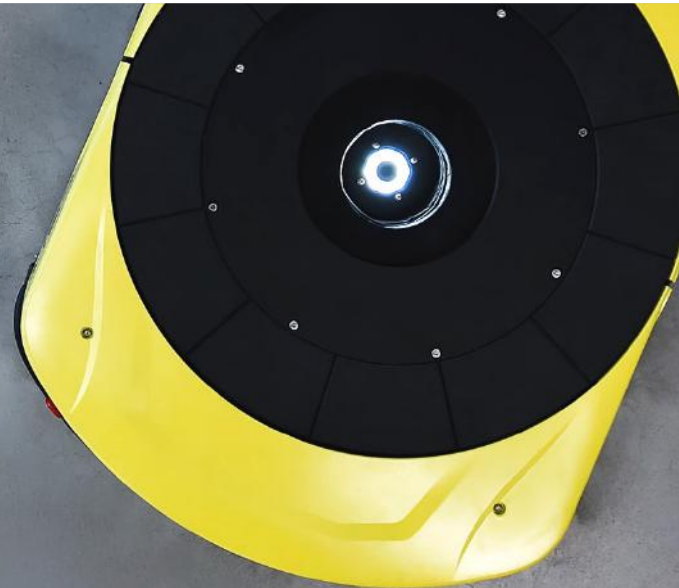
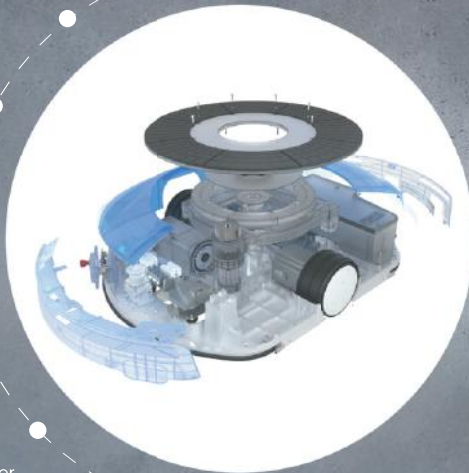

# U800AR

## SPECIFICATION

Type	Under-run with raisable table
Navigation	2D code
Direction of drive	Forward, backward, on the spot rotation
Minimal turning radius [m]	0.5
Max speed [m/s]	2.2
Load capacity [kg]	800
Lift	Electric
Max lift [mm]	60
Dimensions [L, W, H in mm]	980x680x245
Batteries	Lithium
Charging	Automatic - contact
Control	Manual control
Safety scanners	Traffic control, Lidar obstacle avoidance



[asseco-ceit.com](https://www.asseco-ceit.com)

E-mail: [sales@asseco-ceit.com](mailto:sales@asseco-ceit.com)