

international electronic music

Synapse

November/December 1977

Volume 2, Number 3

USA \$1.25

Canada \$1.50

Australia,

Europe & Japan \$2.00

Tomita

Stockhausen



Synapse/Viking Giveaway

Project Dolphin Japan Benefit

More tracks from Four Tracks

GUITAR SYNTHESIS—What's Out There

**It takes a Great Synthesizer to give you the
Sounds you need . . .
It takes a **Cat** Synthesizer to give you **MORE!****



The trio Burns, Renwick, & Rags

There are a lot of synthesizer companies that make great synthesizers. Some tell you that they're number one. Some tell you that they're the first. Others claim their synthesizers are fastest, biggest, smallest, etc., etc. You know what we mean.

Well, we'd like to give you more than just sales pitches. We'd like to show you why a **CAT** synthesizer is simply the **BEST PERFORMANCE ORIENTED SYNTHESIZER IN ITS PRICE CLASS**. Best in versatility. Best in simplicity of functional design. Best in price.

The two oscillators on our **CAT** have a total of seven (7) waveshapes - each with its own volume control. This is the equivalent of having a 7 input mixer - a feature often found only on expensive studio synthesizers.

The sub-octaves on our oscillators gives an effective sound depth of 4 oscillators - a depth that distinguishes the "**FAT CAT**" sound from other competing units.

Our 2-note keyboard can be played either polyphonic or monophonic, (depending on your style) at the flick of a switch.

We also offer you a 4-note sequence patch, a multiple trigger keyboard,

and **CATS** can be connected in series with a simple stereo cable and played off of one keyboard.

But were not the only ones boasting about the **CAT**. International Musician and Recording World*, one of the most respected music publications in the world requested to do an unbiased review on the **CAT** by the famed Rod Argent of "**ARGENT**". Some of their comments include:

"The layout is extremely efficient and easy to follow".

"The range of possibilities from the oscillators alone is extensive".

"The **CAT** also incorporates a very effective transient triggering device which is invaluable should you be playing fast".

"The VCA module . . . is simplicity itself".

"The instrument has a generally rugged and no-nonsense feel about it".

Rod closed his comments with, "I like the **CAT** very much indeed. For a synthesizer set fairly low down in the general price scale it boasts an extraordinary number of features".

Now you know why more and more musicians are choosing the **CAT** over any other synthesizer.

THE CAT, WHERE QUALITY IS OUR MOST IMPORTANT FEATURE.

OCTAVE *Electronics Inc.*
An Affiliate of Syn-Cordion Musical Instruments Corp.

32-73 STEINWAY STREET - LONG ISLAND CITY, N. Y. 11103

*For the complete review of the **CAT** synthesizer by Rod Argent write: International Musician and Recording World, 501 S. Main St., Spring Valley, New York 10977, (914) 356-2570.

Synapse

2:3

Editor
Douglas Lynner

Art Director
Chris August

Photography
Bill Matthias

Contributing Editors
Chris August, Greg Burk

Contributing Writers
Craig Anderton, John Blacet, John Borowicz,
Greg Burk, Alex Cima,
Janet Henshaw Danielson, Jon Dattoro,
Bob Davis, Gregory Allen Fitzpatrick,
Pat Gleeson, Peter Hillen, William Jackson,
Max Von Kunstorf, Steve Roach, Danny Sofer.

Correspondents
Boston: Kenneth Perrin
Northern California: Phil Loarie
Connecticut: Chuck Scribner
Maryland: Paul Medlock
Minneapolis: John Borowicz
New York: Carter Thomas
Oklahoma: Richard Bugg
San Diego: Steve Roach

England: K.S. Dulay
Japan: Eiji Ueda
Sweden: Gregory Allen Fitzpatrick

Contributing Artists
John Adams, John Blacet, Sue Denim,
William Jackson, Adrienne Marie Picchi,
George Sanders (Sando)

Contributing Photographers
Greg Burk, Rhonda Fleming,
Bernard Perrine, Greg Heet

Production
Colin Gardner, Bill Matthias, George Sanders

Line Conversions
John Scheele

Cover Illustration by
Jean-François Podevin

Synapse is published bi-monthly at 2829 Hyans Street, Los Angeles, CA 90026 by Synapse Publishing Co. The entire contents of Synapse are copyright © 1977 Synapse Publishing Co., all rights reserved, and may not be reproduced in any manner, either in whole or in part, without the written permission of the publisher. Application to mail at second-class postage rates is pending at Los Angeles. Manuscripts, photographs & artwork: All contributions are welcome, however, we cannot be responsible for the return of unsolicited materials. Enclose a self-addressed stamped envelope with any contributions and send to Synapse, 2829 Hyans Street, Los Angeles, CA 90026. Advertising Contact Doug Lynner or Chris August at (213) 383-7933 for our current rate and deadline schedule. Distributors & Dealers: Contact Chris August or Doug Lynner at (213) 383-7933 for discount information and publishing schedule. Subscriptions: Within the US the annual six-issue rate is \$6.00. After January 1, 1978 the annual rate will increase to \$8.00. Foreign subscriptions are now \$7.50 yearly, after January 1, 1978 the rate will be \$9.00. A special foreign air mail subscription is now available for \$20.00 annually. Single copy newsstand price is \$1.25; Canada \$1.50; Australia, Europe, and Japan \$2.00. Back Issues: We are presently sold out of most issues. Please send a postcard for our files naming the issues you lack and they will be reprinted when demand is sufficient. Change of address: Notify Synapse/Subscriptions at 2829 Hyans Street, Los Angeles, California 90026. Please send both the old and new addresses, and if possible, the mailing label from your copy of Synapse.

Isao Tomita

"The main purpose was my inner desire; it didn't come from any commercial or business reason." Tokyo, August 1977.

Max Von Kunstorf



17



Bridge Over Troubled Whales

Project Dolphin Japan: Notes on Japan's first environmental music benefit held at Tokyo's Harumi Dome.

William Jackson

22

Karlheinz Stockhausen

"The question is wrong because I started the electronic music."

Part one of two parts—
Cologne, April 1977.

Janet Henshaw Danielson

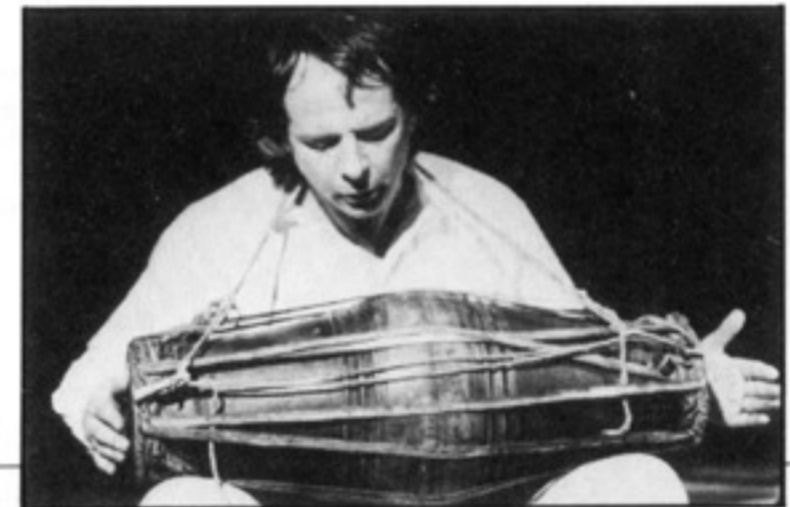

26

John Simonton

PAIA helmsman alive, well, and working hard in Oklahoma.

Craig Anderton

35

Digital Pattern Generator

Build one!

John Blacet

39

More tracks from Four Tracks

Home recording alchemy.

Craig Anderton

37

The Beat Goes On— Part One.

Difference tones, combination tones, & temperament.

Jon Dattoro

41

2:3/Notes from the publishers 2
Letters/Reader feedback 2
What's Happening/Around the world . . . 5
Performance/Screamers, Tangerine Dream, Electronic Weasel Ensemble 7
Synapse-Viking Giveaway/Any two of

your keyboards repackaged, or heavy duty road cases for free! 9
Discola/Tangerine Dream, Jean-Michel Jarre, Alan Parsons, Yes, LEM, & new releases 11
High Points & High Jinks in the History of Electronic Music/Musique Concrète, Pierre Schaeffer 43

Equipment/Syndrum, A/DA Flanger 45
Guitar Synthesis/Playing the field . . . 47
Synthesis/Processing and Controlling . . . 48
Computers/Using an A/D Converter . 49
Listings/Addresses of interest 50
Classifieds/Buy, sell trade, make, and have made 51

Can't Please Them All

Let me congratulate you on your general stupidity and total lack of competence.

Going on three months ago I ordered your periodical. When it didn't arrive I canceled. To my surprise after I canceled, it arrived. I want a full refund.

Typical of your togetherness is the subscription label address as above [R. M. Beta—Ed.] instead of R. M. Vega. This is the letter "B"—it begins the words Bozo, Brainless, Bombastic and Bull—. This is the letter "T"—it begins the words Turkeys, Taciturn, Tardy and Tedious.

Seeing as I am a music teacher you will not be charged for the spelling lesson. However, I am considering writing music stores, electronic suppliers, and other related advertisers to enlighten them as to the quality of your magazine and the effect of your ads on a reader . . . to say nothing of the Better Business Bureau for the Los Angeles area. The content of your magazine clearly outlines the motivation for publishing it. With this in mind . . . it's better to refund \$6 than to lose countless \$ because of bad pr. I anxiously await your reply.

R. M. Vega
Bloomfield, N.J.

P.S. It's very interesting to see Lem personnel & Systems 360 advertising in proximity to Synapse!

I apologize for the misspelling of your name and would like to address myself to two other aspects of your letter. First is your vague and mysterious statement concerning our "motivation" for publishing Synapse. The inference of the sentence eludes me but the intent is clear. To set things straight, Synapse is published to support the use of technology in music and to widen both musicians' and listeners' understanding and enjoyment of electronic instruments. We attempt to accomplish this by combining both technical and non-technical aspects of synthesis within a single format.

If the lack of stylistic criteria are conspicuous in the above, it is because we do not favor particular styles as part of our editorial format. Instead we encourage diversity to nourish growth.

Secondly, your postscript infers less than honest relationships between this magazine and some of our advertisers. Geographic proximity is not in any way a criterion for advertising in Synapse, and I suggest you do not make libelous statements without substantiation.

With this in mind, I hope if you wish to criticize Synapse that you will indicate the object of your criticism in a constructive manner and not in the form of threats and vague allegations. Ed.

LETTERS

For the Beef Eater

Let me be another in a long line of readers to compliment you on your magazine. I would like to emphasize my approval of your "no cow is sacred" editorial stance on product and production alike. This, especially, is what separates you from the rest, and I hope you will forever more retain this special-interest-free status, for your credibility lies therein (look at Rolling Stone!)

Keep making waves!

Ken Jacobs
Mill Valley, Calif.
P.S. How about an article (or two) on Jon Appleton?

Thanks Ken, we will. Ed.

Beyond the Clang Tone

It is good to see Synapse publish articles on patching techniques such as "Beyond the Clang Tone"

voltages.

Readers attempting to duplicate these patches on their systems should check to see if their ring modulator has AC coupled inputs. In some cases, an AC/DC switch is provided, and must be in the AC position for these patches to work as described.

Brett Sher
Freemont, California

Thanks for providing this additional information for our readers. Ed.

Concert Listings

Your magazine is great; I've been a subscriber for a year. One difficulty is, I would like to go to concerts such as the one you mention by the Electronic Synthesizer Ensemble on July 24th, (What's Happening, Vol. 2, No. 2). Unfortunately, I did not receive my copy

Don't get nervous. You haven't missed the September/October Synapse. With our move to increased newsstand distribution cover dates have become a bit more critical, so this issue became November/December—no one missed an issue. Volume numbers are still the same. Why don't you relax, buy a six-pack with the cash you'll save by subscribing or renewing before the end of the year (see the ad on the inside back cover), and anesthetize yourself while reading this bigger and better-than-ever issue.

Feel better now? We do—because Synapse has pulled off another scoop with the Stockhausen and Tomita interviews conducted, respectively, in Cologne and Tokyo.

We've been overwhelmed by response to Synapse in Japan. Our Japanese readers will soon see translated reprints of Synapse features in Rocking F, Jazz Life, and ASCII magazines. Our humblest thanks are extended to Eiji Ueda of Rittor Publishing and Kazuhiko Nishi of ASCII Publishing, both Tokyo based, for their efforts on our behalf. While on the subject of international events: foreign readers, we're looking for correspondents. If you're interested in keeping us informed of events in your locality please write. We are expanding our focus to reflect the truly international nature of electronic music. Synapse is committed to providing a global forum for the exchange of ideas without stylistic bias.

So, readers, dig into this issue, then give us more of your generous feedback. We will do our best to continue providing a magazine worth reading. By the way, response over the last year has confirmed our belief that Synapse will continue to expand. We thank you.

—Doug Lynner & Chris August,
Publishers,
November 1, 1977

appearing in Vol. 2, No. 2.

Steven Bilow has discovered some interesting patches which make use of the DC blocking capacitors on the Steiner-Parker ring modulator.

My criticism is that the article does not make it clear that it is the AC coupling which is primarily responsible for the various effects. By omitting this information, Bilow seems to imply that it is the very nature of ring modulation to respond only to rapidly changing

until Mid-August. How can I find out about concerts in this field before they happen?

William O. McDonald
Los Angeles, Calif.

No excuses for the case you point out (although the concert was in fact cancelled) but we too would like to list concerts in Synapse. When our two month publishing interval and the one to four weeks the mail may take to reach subscribers are taken into account, you

can see we only need to know very far in advance to do it. If readers have concert dates to list, send them to: Synapse/Concerts, 2829 Hyans St., Los Angeles, Ca. 90026 or, call Synapse at (213) 383-7933. Ed.

Back Issues

Found To Be Addictive

I just found my first Synapse (Vol. 2, No. 1). Where have you been all my life? (or at least since Vol. 1, No. 1?)

I read it cover to cover and was extremely impressed.

I am subscribing, but that alone won't quench my thirst. I NEED BACK ISSUES!!! (I'm already addicted). Please, please send me a copy of every back issue you can (All six I hope!).

Please hurry! Your Mag is No. 1! Thank you very much.
Richard H. Nebel
Santa Clara, Ca.

I'm afraid it's cold turkey on Volume 1, Numbers 1, 2 and 3 and limited supplies of Numbers 4, 5 and 6 and Volume 2, Numbers 1 and 2 (see back issue ad in this issue).

You could help Synapse in deciding when to re-print the back issues by sending your name & address on a postcard noting the issues you would like re-printed. Ed.

PAIA/Moog Modification

I'm considering the addition of a few PAIA modules to my Mini-Moog. What advantages would be gained by modifying the Mini-Moog with PAIA's No. EK-3 Keyboard Encoder and No. 8780 Digital to Analog Converter? An insert with my PAIA catalogue claims the introduction of a "polytonic expansion system." Could you explain its application?

Is it possible to modify the Mini-Moog's keyboard such that a second key depressed would control a separate modular system?

Mark Vail
Miami, Florida

John Simonton of PAIA does not recommend the modifications you suggest. He felt that it could be done but it would require technical expertise, and in addition, PAIA is not able to back up the project at this time. The Polytonic Expansion System consists of the EK-3, 8780 D/A Converter and the 8781 Quad Sample and Hold. It is also necessary to use a computer.

Modifications are available to add a "voice" to MiniMoogs but it is a discreet voltage with no trigger or gate and both voices will remain at the voltage of the last key released. In general, with this sort of keyboard you must add busses in order to approach what you're thinking of, but be prepared to compromise the degree of control. Ed.

A Message of Great Importance to Musicians.

Korg proudly announces the most advanced technological achievement in the history of electronic music: The PLS (Professional Laboratory Systems) Polyphonic Synthesizer Group. Developed by some of the world's most brilliant electronic engineers, the Korg Polyphonic Synthesizers mark the dawn of a new age of musical creativity. You've heard that before. But now for the first time Korg's made it true.

The Korg methodology is unique. First, we use synthesizer technology, not a restrictive organ type approach. Then, we don't limit the number of notes you can play simultaneously. The PLS Synthesizers are truly and totally polyphonic. Play all 48 notes at once and you'll experience the thrill of

having 48 mini synthesizers at your fingertips.

Each key triggers its own dynamic filter, envelope generator, and VCA. That means independent articulation of each note. But that's just the beginning. The PLS Synthesizers are modular. Expandable. Totally interchangeable. Patchable. They feature polyphonic, voltage-controlled sample and hold. Plus a host of exclusive, dazzling features we can't begin to discuss.

You'll find the same unparalleled quality, creative technology, and outstanding value in every Korg product. If you're looking for a synthesizer, consider Korg, the keys to creation.

KORG

Another superstar of sound
from Unicord.

75 Frost Street
Westbury, N.Y. 11590

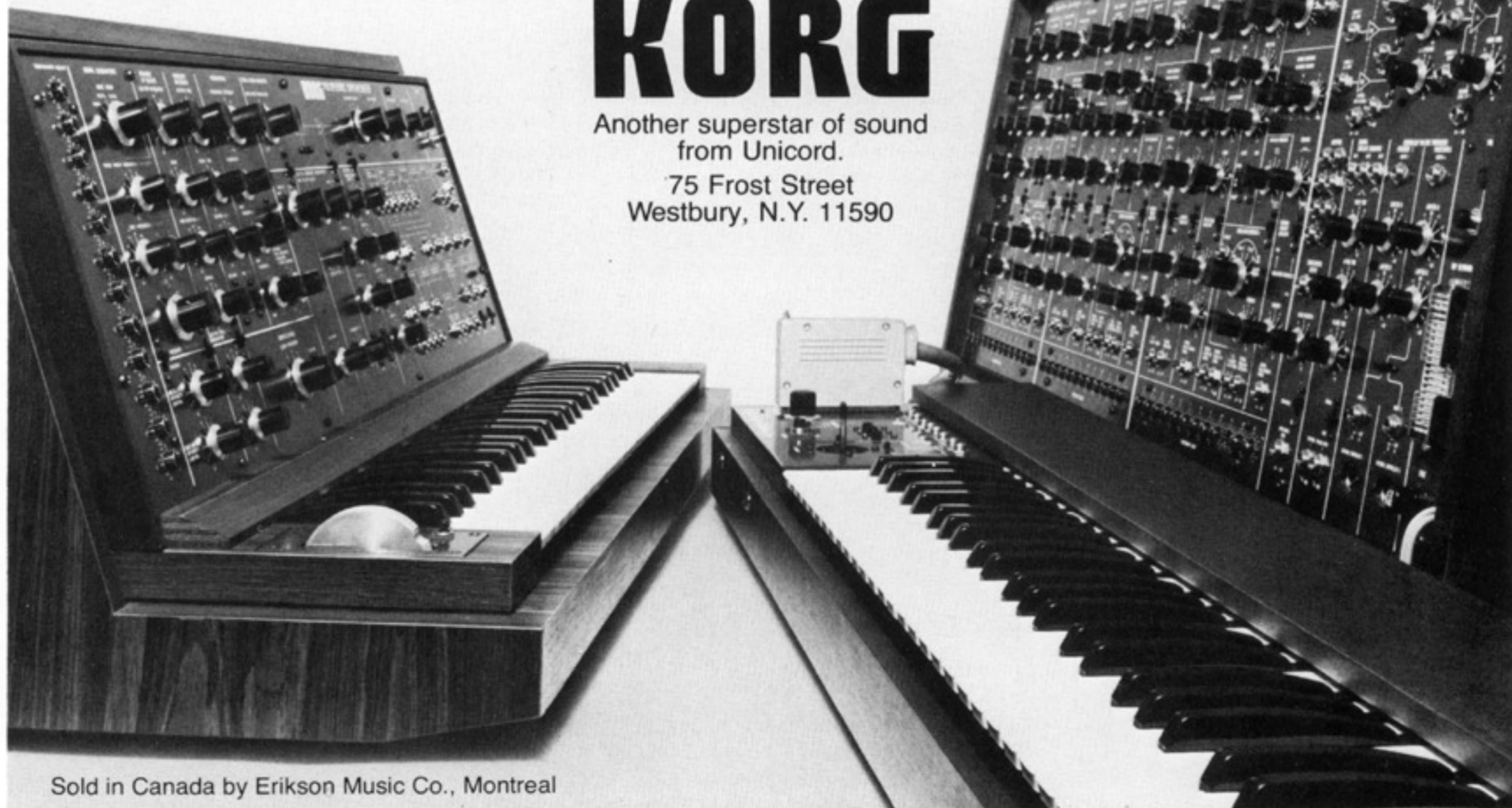

Sold in Canada by Erikson Music Co., Montreal



OBERHEIM PROGRAMMER TECHNOLOGY IN A LEAD SYNTHESIZER.

Oberheim Electronics has been manufacturing Polyphonic Synthesizers for the professional music market for two years. During that period Oberheim Synthesizers have managed to find their way to the finest keyboardists around. Who, in turn have created some of the best music recently released. Consequently Oberheim has become one of the most respected electronic music companies in the world. At times it seems by accident, luck or chance that it all happened so quickly. However, when examined more closely reality emerges. Oberheim addresses the professionals' needs for creative expression with roadable equipment at the forefront of technology.

This philosophy in product development is again exhibited in the introduction of the fully programmable lead synthesizer "The OB-1." The OB-1 combines the simplicity of a preset synthesizer with the versatility of a variable synthesizer yet you're not

locked into factory presets (which are probably some engineer's idea of what a particular sound should sound like). The OB-1 does come pre-patched from the factory for those who aren't into patching right away, so you can immediately use it while you learn the machine. Should you never get into tweaking and turning knobs, cassette tapes will be available (within a few months) along with a tape interface device which will allow you to re-program your machine with a variety of sounds.

On the other hand, being a totally variable synthesizer, those who wish to create their own sounds can! When you achieve the sound you want you can store it in the memory of the OB-1 by simply touching two buttons. The patch will remain there until you write over it with a new patch of your own design or one via the soon to be available cassette tapes from Oberheim.



Oberheim

Some Things Are Better Than Others
Oberheim Electronics, Inc., Dept. O1
1549 9th St., Santa Monica, CA 90401

What's Happening

... Congratulations to Everett Rantanen of Milwaukee, Wisc., the winner of the "Synapse/EML Give Away" of the EML Polybox. Everett synthesizes with PAIA equipment and works as a video game technician. Have fun, Everett.....

... Boston School of Electronic Music, Boston's long standing stronghold of electronic music activity has moved to new quarters at 127 Kilsyth Rd., Brighton, Mass. 02135, (617) 734-4500/4501. Stop by and see them when you're in Boston.

... By the time Synapse goes to press, the First Annual Electronic Music Festival will have presented an evening of electronic music at the Theatre Vanguard in Los Angeles. The festival, sponsored by the Los Angeles



SX-70 BY BILL MATTHIAS

Close encounters of a third kind: Bryce Robbley (l.) of LACEM and Phil "Dronezilla" Loarie (r.) get to know each other at the First Annual Electronic Music Festival.

Center for Electronic Music, occurred on October 14 at 8:30 p.m. and featured works by Louis and Bebe Barron, Justus Mathews, Daria Semegen, Hank Van Draanen, Reynolds Weidenaar, Dan Morehouse, Joseph Ayoob and David Ward-Steinman, plus performances by Phil Loarie and the group Triode. Look in the next issue of Synapse for a review. Rising costs forced the postponement of the advertised LEM concert at the Mark Taper Forum in L.A. Originally slated for October 3, the concert has been tentatively rescheduled for March.

... Heet Sound Products have released the Steel E Bow for sustaining steel guitar strings. (List \$195.). The Steel E Bow emits a pulsating magnetic field causing the string to vibrate like the standard E-Bow for electric guitar. It should make Steel Guitar all the more interesting.

... A very powerful and presently



Joystick from Mediamix.

under-utilized controller is the Joystick. A kit complete with all components and instructions needed to construct and interface an X-Y axis joystick to Oberheim systems is available for \$65 from Mediamix. Turnkey modifications are offered for various systems at \$150.

... Daria Semegen, composer and a director of the Electronic Music Studios, State University of New York at Stony Brook will soon have her work "ARC" released on an album entitled, "Electronic Music for Dance" on Finnadar (Atlantic) Records. ARC was commissioned and

work was supported by grants from the National Endowment for the Arts.....

... On August 11th the Los Angeles Chapter of the National Academy of Recording Arts and Sciences (NARAS) brought together recording artists, producers, publishers, studio musicians, record company personnel, and recording engineers for lunch and to give a listen to a synthesizer band. It was not the first time, but as Bernie Fleischer (President of the L.A. chapter) stated in his welcoming speech, it had been a long time. It was not surprising to find that the first such meeting had been conducted by the late Paul Beaver, the person responsible for introducing synthesizers to the Los Angeles recording community. The luncheon represented an overdue acknowledgment of the role of synthesizers in recorded music but more importantly, it highlighted some of the musicians who keep the synthesizer a common sight in the studios of L.A.

The synthesizer band of the day included Mike Boddigger, Lee Riten-

Synapse asked its Swedish correspondent, Gregory Allen Fitzpatrick, what was happening in Sweden with electronic music and here is what he had to say: "We have one in Stockholm of what they call a major electronic studio, Elektronmusikstudion (EMS). Built in '61 with a government grant it is a class study in digital fetishism; 'look ma, no knobs' just pushbuttons, and lots of them.

"It has 24 hardware tone generators and is driven with an old PDP 15/40 DOS. In many ways it is unique but at the same time complicated, tough to learn, and tough to work in. The technicians and composers working there are very serious people and when during a demonstration I jokingly asked them to fix me a nice string sound nobody even smiled.

"The studio's original inspiration and leader got the boot a year ago for his (unofficial source) dictator-like inclinations and uncompromising attitude. His intended replacement Jon Appleton, founder of the Bregman Studio at Dartmouth with some big plans for modernizing EMS arrived in Sweden in July. Nobody had bothered to tell him that Sweden's composers and kultur administrators (often one in the same person) have a habit of carrying on like bitches in an Andy Warhol film and that at the time of his arrival it was stormy weather in Stockholm.

"Appleton wanted to install a system with 256 generators based upon IRCAM in Paris and a budget was drawn up and presented to the government. But at the same time a government initiated study of the electronic music situation conducted by a composer who was not

continued on page 50

performed by the Mimi Garrard Dance Theatre in May of this year. The work combines computer-synchronized music and lighting scores with dance. Ms. Semegen's

our, Clark Spangler, Abraham Laborial (bass guitar), Mike Baird, and Ian Underwood playing this staggering list of instruments: Polymoog, Moog Modular, Arp Pro Soloist,

Oberheim Four Voice, Arp 2600, 360 System Polyphonic Guitar Synthesizer, Yamaha Polyphonic, ARP Omni, Pollard Industry's Syndrum and a Minimoog.

The concert consisted mostly of original compositions by the performers, an opportunity that comes too seldomly, I'm sure. Although the performance was by no means polished, the energy was positive as was its effect on the audience. Particularly impressive was the lack of clichés such as rampant pitch bending, pretentious sequences and Donald Duck like filter envelopes. The groups' sound was well integrated and at times the synthesizer basis of the group was not even evident to the ear. Good players, good music, and good food all contributed to a fine afternoon, thanks to the Los Angeles Chapter of NARAS.

... Electro-Harmonix has released a fully packaged analog delay line, the Memory Man Deluxe. Delay is variable, from 15 msec. to .4 sec. with a



Electro-Harmonix Analog Delay.

frequency response of 10 HZ-3KHZ from the echo output. The unit, featuring a built-in noise gate, lists for \$279.

... If petty competition has got you down, take heart. A new advertising tact is being taken by 360 Systems and Oberheim Electronics. The OB-1 and the Slavedriver, a programmable synthesizer and a guitar/synthesizer interface, respectively, are being advertised as a package and may represent a first in synthesizer marketing.

... C.F.R. Associates is offering a Serial Analog Delay IC. The chip features 1024 stages of "bucket-brigade" shift registers in a 16 pin DIP package. The IC (I.D. # 922-0018) is available for \$14.00 each and \$11.50 each in ten-piece quantities, and includes application notes and data sheets for constructing an audio flanger and other processing devices.

please turn the page

You can improve your synthesizer!

From the land of high technology electronics comes the **Mediamix Mods**. If you own an Oberheim, Odyssey, or Mini-Moog Mediamix has a goodie to make it better. Here's a partial list: **Two-Voice Mod** for Mini, **Triangle Wave Mod** for adding that fat sound to your Oberheim, **Programable LFO** for most synthesizers, a really incredible sounding **Ring Modulator** for any input, instrument or voice, **Auto Spacial Manipulator**, and of course the **Mediamix Joystick**.

Our Joystick is making us famous among musicians who want to be freed from the fixed keyboard style (and the non-human electronic effects like glide, LFO vibrato, etc.). Play with the expression of a great guitarist, violinist, or trumpet player. With one free hand you can modify pitch and timbre with just the right human touch. Available in kits or assembled units: designed for integration into your model synthesizer.

Mediamix
4060 Stanford
Dallas, Texas 75225
(214) 368-6846

Write or call for complete information. Send \$2.00 and we will send you an audio cassette demonstration.

What's Happening

... Polyfusion has released their 2050 Series Keyboards. Features include pressure and/or velocity sensitivity, "micro-touch" octave transpose, selectable logarithmic/linear glide, one and two voice, and an X-Y axis, joystick controller. Prices range from \$595. to \$795. A Keyboard Interface (\$95) allows the keyboards to be used with most synthesizers, including the Moog "S" trigger. The pitch contacts of 2050 Series keyboards are hermetically sealed and covered by a 5 year warranty.....

... The Frogg Division of Design Engineering Laboratories have released a new contender in the increasingly competitive guitar synthesizer market. The Spectra-Sound Guitar Synthesizer features pitch and volume extraction as well as 2 VCO's, 2 LFO's, 1 switchable VCF, sample and hold, and pre-set interval controls. The unit complete with foot pedals sells for \$1,795.....

... Those who have not seen RMI's KC-II (keyboard computer) should check it out as it is truly a keyboard chameleon. Tones are produced by regenerating a waveform encoded on a computer card. It is possible to have separate or multiple voices through the use of twelve independent Digital Voice Processors. The KC-II retails for \$4,750.....

... The Department of Music, University of New York at Stony Brook Long Island, presented a concert of

"Electronic and Computer Music" with instruments in live performance on October 21. The concert featured works by the composers' Arel, Dolatshahi, Goldberg, Gressel, Hudson, Lauth, Semegen, and Whittenberg. .

... The Electronic Synthesizer Ensemble is presenting a series of informal concerts for limited audiences. Members of the group include Jill Fraser, Ronald Davis, Robert Miller and Darrel Johansen. For information and reservations call (213) 461-7987.....

... Korg will soon release a programmable pre-set device for use with its PLS 3100 and 3300 synthesizers. Also planned are a polyphonic sequencer, remote keyboards and pedal controllers. The Professional Laboratory Systems product line is Korg's recent entry in the polyphonic marketplace.....

... The Carol Conway Dance Company will premiere "Arrow," December 1-4 at the American Theatre Laboratory, 219 W. 19th St., NYC. Also on the program is "QN 152" with an electronic score by Richard Einhorn and James Lauth. For reservations, call (212) 924-0077.....

... The Stylophone 350S is a stylus controlled mini-synthesizer manufactured in England and distributed in the U.S. by Audio Arts Inc. The Unit is promoted as being for "professional, amateur or frustrated musicians" and as "ideal for the vacation home, trailer or boat." The Stylophone 350S is being advertised on continued on page 52

Synapse

Synapse
Back issues are available!
Get 'em while we got 'em!

QUANTITIES LIMITED

Volume 1 Number 1 Interview with Alan R. Pearlman of ARP SOLD OUT!	Volume 1 Number 2 Interview with Morton Subotnick SOLD OUT!
Volume 1 Number 3 Kraftwerk, Tom Oberheim of Oberheim Electronics SOLD OUT!	Volume 1 Number 4 Malcom Cecil & TONTO, Bob Easton of 360 Systems SOLD OUT!
Volume 1 Number 5 Interviews with Pat Gleeson and Gary Wright \$1.75	Volume 1 Number 6 Roger Powell & Todd Rundgren, Synthesizers on the Eco-Front \$1.50
Volume 2 Number 1 Robert Moog, Herbie Hancock, George Duke SOLD OUT!	Volume 2 Number 2 Tangerine Dream, Bernie Krause, Synthesized Video SOLD OUT!

All of you interested in the unavailable issues please send postcard requests for our files. When we have enough requests we'll be able to do reprints.

Synapse Back Issues
2829 Hyans Street
Los Angeles, California
90026

PERFORMANCE

The Screemers

Synthesizers pollute the New Wave.

ScreamersScreamersScreamers Screamers. Um we the people like Punk cuz it's dumb. We like it cuz it's funny. We like it cuz it counteracts pop novocaine. We like it cuz it's unprofessional. But it is kinda predictable.

Like in L.A. you can predict this: If the sign says New Wave, you will probably get, without discrimination and often on the same bill 1) Hard core manic anarchic guitar-bashing Sex Pistols imitations like the Weirdos. Music's not really "new," but heart's in the right place like mid- to late-sixties Who or Count Five louder and faster, all right we like it. 2) Glossy and less interesting attempts to duplicate the preceding and cash in on the "trend." 3) Rank poseurs and incompetents, sometimes having grotesque entertainment appeal.

But there are exceptions. Like *Slash*, the local punk magazine, sometimes holds benefits to aid its noble cause at Larchmont Hall, an obscure backstreet place more accustomed to holding afternoon lectures on plant care than safety-pin demolitions. So here it comes: The evening starts out according to pattern. The *Dils* bang with almost spellbinding ferocity, stamina, and single-mindedness through their set, pausing only to tell the audience to "applaud or go outside and jerk off." Next up, the *Germs* chant out their music to a vague beat much like a long-decayed Tarzan soundtrack, while spitting various substances over each other's bodies. The singer (age maybe 17) constantly lurches out into the audience so they can beat up on him. They desecrate the flag. For color, a hall attendant with a bandage over his right eye (previously wounded in action by a flying bottle) retrieves and rescues flag. And at least the attendant means it, this is no show. *Germs* drummer gets in a fight with a de-motorized audience member. Everybody has a good time.

Then look out, Screamers ScreamersScreamers. For a second it looks like more of the same. Same crazed autistic

mommy - I - fell - off - the - water-tower stares. Same flies trapped in vaselined porcupine-quill hair. The robot-convulsion singer even wears a garbage bag. But something's off balance, and just a quick whip-pan across stage is enough to figure what it is: **There are no guitars.** And what's worse, once the music starts, it's not hard to tell that the sounds coming out are those of . . . ickkk . . . a synthesizer. Yes, that instrument rated nearly unanimously in the latest popular poll as being furthest from the Vital Roots of the Music. Eeuuww.

Here it comes, big beats, big riffs just like you'd expect from guitars, but with throbbing drones, frantic yelling. Repetitious, loud and unsubtle. Kinda stuff the deaf or this correspondent, for instance, could respond to. Very different. Songs like "Peer Pressure," "Magazine Love," "Going Steady with Twiggy." Androids on culture overdose. The audience doesn't know exactly what to do. Fighting doesn't seem quite appropriate. You can't really pogo to it. Some just kind of stand there, locked in, almost as if watching TV; with one important difference. They're interested. Others carry on as if nothing's changed, pulling on Tomata's garbage bag and doing what's expected.

"In order to preserve my dignity," says singer Tomata (pronounced much like the standard



salad ingredient), "I would have had to take off my pants."

Dignity, though, is not the main point. As to popular musical tastes: "People have to evolve or become extinct," observes Gear, jerker of the synthesizer and rhythm generator. The Screamers see their music as being emotional and direct, well

off the detached cerebral rails of many of the more celebrated progressive wire crossers.

Top 40? Playing the Forum? Sure, why not. But the so-called L.A. "New Wave" bands? "We despise them," states Tomata flatly. Gear: "It's like being in a wax museum where the figures are quickly melting. We are the only really new musical perspective we've seen in L.A."

By way of grabbing any kind of rare opportunity for exposure in a city where showcases for new music are absurdly few, the Screamers recently hauled Arp synth, rhythm machine, mikes, drummer K.K. and electronic piano with envelope follower over to Iggy Pop's house for a demonstration. Impressed, the head Stooze and Bowie crony, having spent too much time in Germany lately maybe, billboarded the Screamers with the tag/slogan/rallying cry "Tomorrow's Leaders." Uh, yeah. Achtung, everybody.

—Greg Burk

Tangerine Dream

*Greek Theatre, Los Angeles
July 12, 1977*

When the chance to review this concert was presented me, I was elated. At last I would be able to praise a group that I have emulated for years now. The way Tangerine Dream fuse their minds and equipment to create mental space scapes is a truly moving late night listening experience.

I heard the Dream's "Phaedra" recording on an early morning FM radio show a few years back. I was captivated by this totally new sound. From that point on I have listened and watched the Dream grow into what appears, by concert crowd reactions, album sales, etc. to be a promising new sound for America to turn to.

Being a lover of Dream that I am, the performance at the open air Greek Theatre was a disappointment for myself and friends. It was no more than four months prior to this concert that I caught T. Dream on the last show of their North American tour at the Santa Monica Civic

Theatre where they performed superbly to a sold out house. I was expecting more of the same at the Greek Theatre.

The show started with a barrage of phased noise, a simple cliché made worse by the visual impact of the Dream's wall of complicated modules and numerous keyboards. From that point the familiar Mellotron, Froese style, was heard clearing a pathway for Baumanns rhythm computer to hammer out various note patterns for the group to improvise on throughout most of the first half. Over use of Mellotron made portions go from melodic to muddy more than once.

The visuals used were films, screened behind the group. They were effective on occasion. One film gave the feeling of riding through a constantly changing multi-colored tube. Just about the time you would start to get into it, the film would change or a large hand from the projectionist might be seen, all of this adding to an insipid first half.

After a brief intermission with restless concert goers still looking for their seats, the second half began. Starting with a little more imagination than before, they used their instruments to conjure up a more spatial mood.

The show continued with more improvisations and some familiar album material, taking me to the low point of the night. Froese's guitar playing left something to be desired. On his albums it adds a nice touch, but live it becomes rather intense. In the middle of Froese's radical guitar came billows of smoke which engulfed the entire stage and lingered for quite some time. While a repetitive percussion sequence and the guitar continued, a laser beam danced on the tall trees behind the audience.

With the final sounds of the concert echoing through the hills of Griffith Park, the lights back on, I sat back in my seat with many thoughts to deal with. The Dream is capable of doing fine shows if they want to. With their rise in popularity they have developed a style that is once again their own but it must be handled with care. Now that the Dream is touring their patch-cords off it could be easy for

PERFORMANCE

them to exploit their music into a bland heap of sound which was present in parts of both concerts I saw. At this point I must agree with Richard Einhorn's review of T.D. (Synapse, Vol. 2, No. 1). Much more thought and care would make a Tangerine Dream concert an exciting experience. —Steve Roach

Electronic Weasel Ensemble Celebrates 7

Berkeley, 7/7/77

It was the Seventh Annual Festival of Weasels. On the program were seven works "featuring music with seven beats, seven notes, seven voices, and seven-pointed stars" for an audience of 49 (7x7), the date was 7-7-77 and the concert to begin at 7:77. I felt particularly well suited to review this concert as my birthday this year fell on 7-17-77.

The Electronic Weasel Ensemble is a group whose name is derived from a word play on Music Easel. The Music Easel is an analog synthesizer designed for live performance and manufactured by Buchla and Associates. Therefore, this group specializes in real time performance of electronic music.

At the end of my ride lie 1750 Arch in Berkeley, Calif. This is a mansion converted into a lovely and unique setting for chamber music with a chamber size recording studio in the basement. This house on the hill has become a center for quality music during its five seasons and recently they've started their own record label (yep, 1750 Arch Records). Several of the selections from their catalogue are of interest to electronic music fans. One is Charles Amirkhanian's recording of American text sound pieces called "10 + 2:12." They also distribute two recordings by the jazz oriented Denny Zeitland Trio.

The Weasels and 1750 Arch go way back. Why, their annual Halloween concert is on its way to becoming an institution. Therefore, it was extraordinary that the concert's greatest fault was that its scale and concept clashed violently with the space.

The evening was planned to be almost an extravaganza presenting seven pieces many of which required extensive electronic set-ups. This seemed to have no place in such an intimate performance area. From what I can judge there's nothing bigger than a string trio with added shakuhachi there the rest of the month! As a result, most of the performers came to the audience via the wonders of television since they couldn't fit in the space. As a matter of fact, the audience didn't fit in the space either and people were turned away.

On stage there were monitors on which much of the concert was watched. There was no explanation as to where this signal was originating. Eventually, as one overheard the performers talking between pieces, it became apparent that the bulk of the electronic gear and impromptu video studio were in the house nextdoor. This format was not used well and severely hampered several of the four or possibly five pieces which made use of it.

Perhaps the worst victim of video was the opening piece, "Misram Allaripu," a Classical South-Indian dance (Bharata Natyam) in sevens. This dance is the traditional invocation to the opening of a recital. The room darkened and the TV came on. A tape of Indian music began and Kamala Cesar performed the dance. Having this dance presented on a black and white 26" monitor reduced it from a potentially powerful mood setter to the spiritual depths of Saturday afternoon television. The medium robbed it of its subtlety and beauty. The dancer seemed to use little space and from all appearances the only reason the dance wasn't performed in the same room as the audience was that the stage was occupied by seven microphone stands. None of these were used until the fourth number when only three mic's were needed. All symbolisms aside, I'd rather see a live dancer.

The second presentation was entitled "777 (time in seconds)."

It began with a sensitive piano improvisation by Charles Mac Dermid. He was joined by Tom

Buckner, baritone, singing from the floor above. Slowly the singing gained in volume and descended the stairs. The singer's appearance was marked by a large leather cowboy hat and jacket. These he removed melodramatically upon reaching the stage. For the entry Mr. Buckner sang a series of glissandos with his mouth closed. The result was like a theremin which produces a square or nearly square wave. The technique hardly warranted the depth of exploration given it.

"Saturn and the Seven Ladies" by Allen Strange performed by the Electronic Weasel Ensemble (Don Buchla, Allen Strange, David Morse, and Steve Ruppenthal) followed. Very thoughtfully there was an example of the score and a small commentary by the composer provided.

Although the score tells the performer which patch or stage of the patch to play there in no indication given about the interaction between the players. This makes the piece have many aspects of a jam. The performance suffered from many of the problems which beset any improvisation ensemble and I take this as a sign that the Weasels don't play together too much between performances. It started very slow and cautiously and it went on too long, by about a third. By the end, the players had stopped meandering and were centered in on what they were doing. This produced an impressive ending which took some minutes to rise to its forceful, shrieking, cadence.

The performers of this piece were in the building next door. The monitor displayed a brilliantly colorized image of the players at work. Here the video was skillful and became a fine compliment to the sound. The limp beginning of the audio was greatly aided by the visuals. This vivid hue-escent screen was the work of video artist Sharon Grace, assisted by Don Day and Ken Beckman.

Rounding off the first half of the evening was Daniel Lentz's "You Can't See The Forest . . . Music for three wine drinking speakers and seven cascading echoes" performed by Stan Cary, Gary Eister, and Daniel

Lentz. The composer spoke to the audience first in an engagingly casual manner. What he said might have sounded like a series of apologies were it not for the tone of his voice and manner of delivery. Very tricky ground to venture out on. He described this piece as being written "seven years ago" and being his "seventh favorite" of his pieces from that time. "We get scared each time we perform this piece. Its very scary. Sometimes we get sick." The reason for this is that the three performers drink about two bottles of wine in something considerably less than ten minutes.

The piece was played with enthusiasm and skill. It consisted of each person saying a part of a word into their mic and then hitting their glass with a mallet and/or drinking some of the wine. The score must have provided exact directions for all of these activities. As more and more wine was removed from the glass the pitch rose. These sounds went into a tape delay and, as the wine loosened up the players, clichés like the one in the title began to emerge. It was a true high point of the evening when the final loop sounded the clichés plus their rising accompaniment of boings on the glasses. The performers each flashed flushed smiles and the assembly moved out to the patio for 7UP.

"Totemic Illusions: Seventh Trance" by Steve Ruppenthal opened the second half. This piece is for female voice, performed by Michele Cesar, and live electronics. The composer's notes explain that the piece:

Utilizes a spoken text from various linguistic images of North American Indians. The illusions draw upon relationships between the electronic and vocal sounds to form a connection between the concrete (earthly) and the abstract (totemistic) worlds. The seven illusions are: Gretry Remembered, Results of natural conditions . . . a system of spirits, thunderers, guardians, and illusions from within. The opening is an expression of the nature of unity between Ancestral Spirits, taboos, the children of 'god' and their active totality.

Before the piece began it was explained that "Totemism is a

hysteria in which there is no difference between madness and sanity." I couldn't say if the composer be sane or mad. (I couldn't even answer that about myself.) But his music is beautiful and evocative. The woman's voice is run through a tape loop which isn't allowed to play continuously thus saving this cliché from intruding into an original piece. Again the performers were presented over colorized video. However, by now the technique begun to wear thin and by the end of the piece I found myself closing my eyes or looking away from the monitor more than earlier in the evening.

Bright and bouncy "Dutiful Ducks" was next. This is a text-sound piece by Charles Amirkanian. Six men were on stage with the soloist coming over the monitor for no good reason except that they had the video already set-up and working. This, however, did not detract from this spirited speaking and clapping piece. The performers were Don Buchla, Daniel Lentz, Frank McCarthy, David Morse, David Rosenboom, Steve Ruppenthal, and Allen Strange. Perhaps the best part was seeing the performers having such a great time with this high energy collection of often repeated words. The text as given in the program is:

dutiful ducks
dududutiful ducks
suitable, beautiful ducks
the draino ducks collide:
and curtsy

It reminded me of a child's game song from a dada land that's somehow right next door to Tin Pan Alley.

The seventh piece on the program was "7-7-77 with Maple Sugar West." This is one of a new genre of new music pieces/groups who take the line which traditionally divided "art" or "classical" music and "folk" music (which has many forms such as rock, blues, country, soul, jazz, pop, and others) and simply violates it. The set began with a piano improvisation by Dave Charles (aka David Rosenboom) who was later joined by Rosy Dawn (aka Michael Byron) on trumpet. The music moved at a frantic rate with Dave Charles running all over the piano like a latter day atonal Art Tatum. Rosy played his trumpet into a low mic behind a baffle. The mic fed into a synthesizer and the trumpet gated and trig-

Synapse GIVEAWAY



Synapse, in conjunction with Viking Keyboard Systems, Inc., is giving away a

Viking Keyboard System

Any two of your keyboards with up to any four modifiers (mixer, echo unit, phasor, graphic e.q., etc.) repackaged in a custom-built two-manual system. A pedal effects guitar system or custom cases may be substituted at the winner's discretion. The Viking Keyboard System list value is \$400.00.

To enter, send your name, address, and telephone number on a postcard to: Synapse/Viking Giveaway, 2829 Hyans Street, Los Angeles, California, 90026. Enter as many postcards as you like. Entries received in subscription envelopes are disqualified. All entries must be postmarked by December 30, 1977. Drawing will be held January 6, 1977. Winner will be notified by phone. Void where prohibited.

Synapse

What is A Robot in Heat?

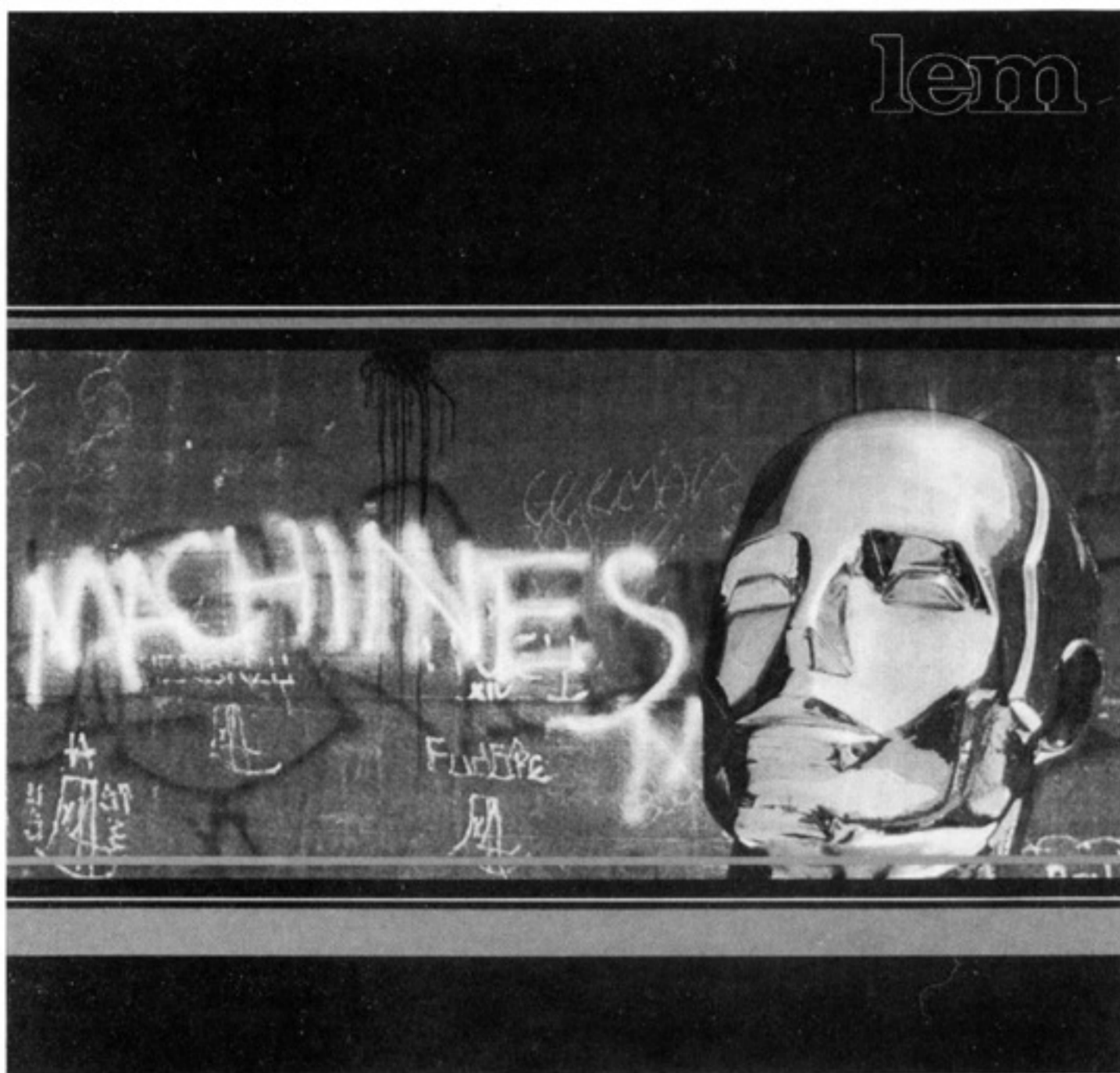

Evan Caplan drums & Syndrum. **Alex Cima** synthesizers & piano. **Doug Lynner** synthesizers. **Bryce Robbley** synthesizers & vocals. **Danny Sofer** synthesizer & drums. **John Stubbs** violin. **Wah-Wah Watson** guitar (courtesy of Columbia Records). Produced by **Bryce Robbley**.

"A futuristic mind excursion into the realm of electronic music. . . . ahead of its time. . . daring and complex." — **Billboard** 10/8/77

Blue Meanie Records, Music Plus, Licorice Pizza, Warehouse, Tower, Music Odyssey, Record Trading Center, Rhino Records, Peaches Records, Wilcox Records, Poo Bah's, the Black, Isness Records, UMS Discount, Vogue Records, Sound Music (Platterpuss Records), and Euphoria Records.

They know.

Mail order: Send \$6.95 (California residents add 6% sales tax), outside USA send \$7.95 (US funds only) to:

Wavefront Records
8615 Santa Monica Boulevard
Los Angeles, California 90069

PERFORMANCE

gered several electronic sounds. The most memorable was a low percussive sound which happened just often enough to remind me of a 250 lb. double bass player nodding over his instrument during a gig.

J. Jasmine (aka Jacqueline Humbert) made her entrance dressed in a well fitting man's suit with a large man's hat and very womanly high, high heels. She picked up a mic and sat until the music took a drastic turn and went tonal. A regular jazz vamp, intro, and we're into the first song. During solos and breaks the music would return to the machine gun style jam, a device which effectively unified this three number finale.

The first song was "Androgony." Each time the chorus came around "It's just one more thing you can use to be free" I wished I'd remembered to wear my nylons. Another was truly a modern "working girl's" fight song and was dedicated to Coyote and Margo St. James. This blend of night club style vocals, lyrics carefully chosen for their sexual revolutionary snap, free jazz, and new music synthesizer defies the traditional classifications. It belongs with the rock groups who are now expanding themselves conceptually or the "classical" groups who are using their media in a more popular style.

In the middle of this last group the television monitor came on and began showing colorized video of the unused electronics equipment from the house next-door. After the audience had already sat through about 3/4 of an hour of colorized video, this was a detraction from the unified visual of the live performers. Here was an intrusion of meaningless rococo technology. Then as suddenly and as without motivation as the monitor came on, it went off. I at least, was confused.

The audience gave the last group a good round of applause and the seven seven's seventh seven sevened to an end. The concert was an ambitious pot-pourri of many styles and persuasions current in New Music today. If the quality of the pieces and performances varied, that seemed only natural when such a diverse selection of artists and composers is presented.

—Bob Davis

Tangerine Dream

Music from the original
motion picture soundtrack

Sorcerer

MCA Records: MCA 2277

Not that many directors generally conceive their film as part of a music score but director/producer William Friedkin must admit to extremes, as he readily states that the musicians had never seen any of the footage to his adventure film. Generally, composers are subjugated to timing cues and moods otherwise not their choosing. The film plot however is begging for the sultry, mantra-ish, mysterious web drawn by the Dream's instruments . . . since Tangerine Dream has successfully developed a style consisting in rolling sequences and suffused Mellotron horns, flutes, and the like, it is not hard to sense the right moments where the editor faded the soundtrack in and out.

Some of the music was quite incidental but not by the Dream. In numerous scenes, what purported to be original latin rhythms was evident and much enjoyed (most of the action takes place in a latin tropical environment). These were not included in this particular album.

Besides opening and closing the film, most of the score was best used during tense dramatic moments such as the impending slips on shaky



turns being negotiated by a dynamite loaded truck. The repeating sequences do indeed make them attractively hypnotic, yet they must certainly be aware of instrumental underuse . . . the lack of variety in rhythmic elements is matched by a static flow of harmony.

The best cuts were Rain Forest, a jazz flavored, frog studded sound track; the following cut, Abyss, projects great dissonant string chords yielding later to consonance and the obligato faded-in sequence. Impressions of Sorcerer was a study on Carlos Santana (by the way, do not be misled by the movie's title. Students of Carlos Castaneda will be sadly disappointed as the film is about people running away from murder, bombings, fraud, and the like).

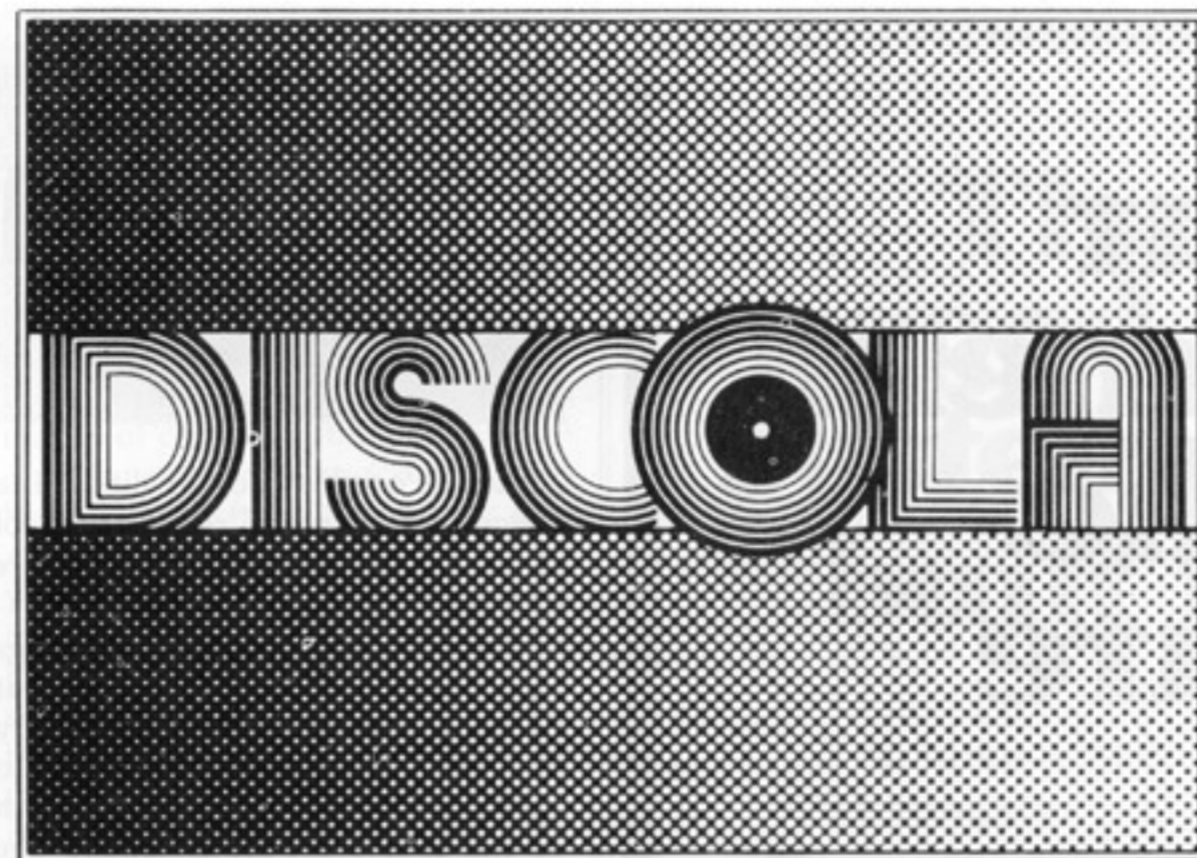

The least liked cuts were Betrayal and Vengeance, which consisted of lengthy Ravel Bolero type sequences and mellotronics.

The Dream's synthesizers seem to have a particular timbre about their ring modulator/filter patches which make them most pleasant and unusual.

—Alex Cima

Jean-Michel Jarre

Oxygene

Disques Motors (French import)
and U.S. Polydor

Cosmic music is alive and well and living in Europe, particularly in France and Holland, where this record has been seen hovering near the top of the record charts.

"Oxygene" initially sounds reminiscent of Kraftwerk & Tangerine Dream, with the sequencer bass, rhythm box drums and simple melodic lines that they all have in common, but beyond that, the groups are quite different. Both Kraftwerk & Tangerine Dream have a streak of impressionism in their music, with Kraftwerk's characteristics of freeways and railroads, and the Dream's impressionist textures (in particular, compare the first five minutes of "Rubycon" with the be-



ginning of Ravel's "Daphnis & Chloe"). However, the Frenchman Jarre is more a romantic than an impressionist: his music is closer to

Chopin than Debussy; also to French romantic movie music, like "A Man & A Woman", to the char-teurs of love songs, and occasionally Terry Riley's eastern ramblings.

Jarre uses ARP, Moog, & EMS synthesizers, string ensemble, Mellotron voices, and lots of echo to weave his textures from one movement to another of "Oxygene." Most of it is in 6/3 time, sort of a cosmic shuffle, with a pedal bass and parallel triads above, on string ensemble or voices. On top of that is a solo line, sometimes melodic, sometimes just electronic artillery. There are interludes of space sounds and the cosmic ocean (pink noise) which segue between the different rhythmic sections in the piece. The sound is rich, but never too cluttered, perhaps because of the limitations of 8 track recording.

Some of "Oxygene" is dull and some downright dumb sounding to be sure, but most of the record is quite serious and very beautiful. Jarre puts some warmth into a style of music that has been criticized as being cold and repetitive, which makes for some interesting listening.

—Danny Sofer

The Alan Parsons

Project

I Robot

Arista 7002

The studio prodigy and his crew having tackled the works of Edgar Allan Poe have now turned their conceptual thoughts and tape recorders to the future and man vs. machine issues. *I Robot* is intended as stated in the liner notes as "The story of the rise of the machine and decline of man, which paradoxically coincided with his (man's) discovery of the wheel . . . and a warning that his (mans') brief dominance of this planet will probably end because man tried to create ROBOT in his own image."

Sounds like a terrific premise for an "album for T.V." series spanning the time from B.C.'s Neanderthal days to Luke Skywalker's galactic era. Picture the opening episode where the seeds for the robot take-over are planted. B.C. and Peter are recklessly driving about on B.C.'s turbo-charged wheel creating all sorts of social mayhem in addition to damaging the environment. Suddenly, they crash into their creation—Grog, the Robot. Grog is attired in a "basic" three piece brushed aluminum suit bejeweled with a string of LEDs—his number-crunching outfit. Grog noticeably upset about the dents decides these humanoids have 'bugged' him for the last time. He proceeds to tie them up with punched paper tape while spewing forth (via D/A) warnings of man's demise and the Robot's Creed—not to be like you (man)!

The sets, special effects, and background music for this would-be series could be spectacular, but the way the execs would go about presenting the premise and characters would be in a word—lacking. So is the album and its execs.

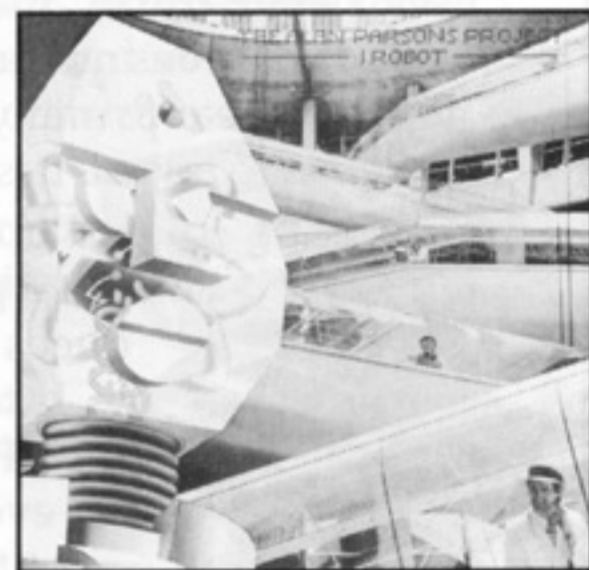

The most noticeable aspect of the album is that sound, that "Allan Parson's sound." I have nothing but admiration for Parson's engineering. He uses the stereo field, all of it, and well. The imagining is superb. Further, his employment of electronic and studio effects are tasteful and restrained. Bravo.

Musically the album doesn't equal the technical accomplishment. It is for my taste too uneven—a musical ping-pong match. The evocative, layered wood of the title cut is squashed to oblivion by the mediocre lyrics and relentless heavy disco beat of the song that follows, "I Wouldn't Want to be Like You,"—the Robot's Creed! The programming of the side's remaining material had me bouncing as well. "Some Other Time," an ethereal, emotional ballad complemented with a forceful arrangement is shot to hell with the two non-descript, "I've heard it before, so what" tunes that follow. Side two's high spots appear in order of appearance," surrounded by "pop" pabulum like Side 1. "Nucleus" on Side 2 is worth a mention simply for the imagery it paints in the mind's eye. The timbres weave together forming a floating texture.

Your Instrument of the Future

Technical Research Institute Inc. is committed to the development of a keyboard musical instrument that produces the sound of all acoustic & electronic musical instruments. It uses **Laser-optic memory** discs, does not have tapes to wear & many heads to adjust. It is



ORCHESTRON MODEL X
PHASE FOUR...

not a souped up combo organ with simulated pre-sets, rather it produces its sounds by **Modulated Light**. It has **Full Polyphonic** capability, every note will play. Laser-optic technology allows the keyboard musician to produce the actual sounds of human vocals, string sections, horns, pipe organs, synthesizers, or any sound that can be recorded. Every



ORCHESTRON MODEL
DOUBLE "D"...

Orchestron is packaged in the world's most rugged keyboard case by **Viking Keyboard Systems**. Call now for more information 813-522-2118.



ORCHESTRON
MODEL "D"...

There's none other like it.
Orchestron
A PRODUCT OF TECHNICAL RESEARCH INSTITUTE INC.

3092 - 47th Avenue North, St. Petersburg, Florida 33714

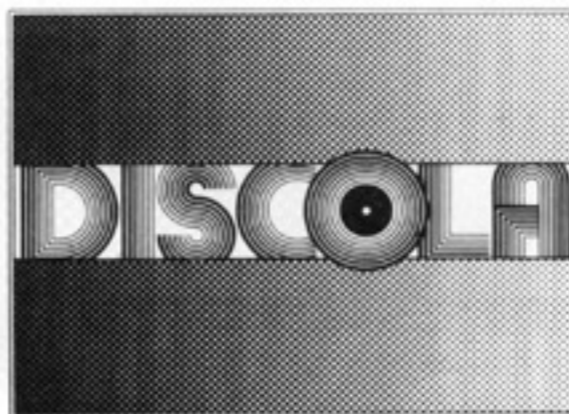

Andrew Powell's "Total Eclipse" is a Leggeti-esque piece reminiscent of *Atmospheres*, used in *2001: A Space Odyssey*. Very effective.

The way this album ping-pongs about gives me the impression that Parsons and crew very carefully planned and prepared this album to appeal to the greatest—widest swath of humanity. If this is indeed the case, they did an excellent job. There's something for everyone. Still it doesn't have the artistry nor the polish of *Tales of Mystery and Imagination*, yet it does have that "sound." *I Robot* is a great album for parties as background music, but if you spin it for a serious listen and if you're a fan of *Tales of Mystery*—my condolences.

—John L. Borowicz

Yes Going for The One Atlantic SD 19106

Interestingly, the principle question surrounding this recent release was not concerned with the good-bad value judgements of Yes' artistry. All of that questioning and answering seemed positively predisposed. The question: how's Wakeman?

A nebulous query for one of the "uninvolved," indeed. Yet, to the devout Yes follower/fanatic (as is this reviewer) the question's meaning and intent is very clear.—A little history music maestro if you please —When Rick left Yes to pursue a

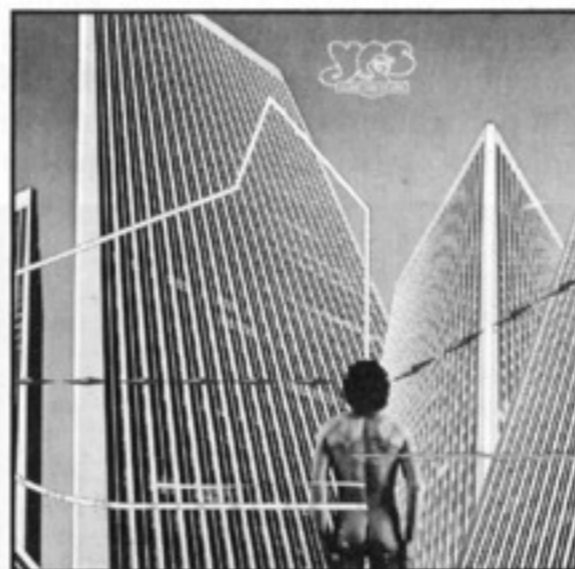

career of obscurity (as my colleague Tom Davey so pointedly phrased it), Yes fans were confused and worried. Rightly so, Wakeman made his mark and presence known. Fears, worry, and the bottle of Gelusil were laid to rest shortly after the release of *Relayer* which introduced the replacement—Patrick Moraz, who

was brilliant and added a new facet to Yes' diamond-quality music. *Relayer* was followed by the solos, Wakeman continued his rise to new heights of obscurity (the Davey principle?), and Moraz decided to say bye-bye. The faithful were in a turmoil. Wakeman left, now Moraz has left . . . who could fill those gloves?!

Wakeman's back and better than ever, and the album—is it good? My friends it is tremendous. Spectacular. These guys are true wizards!

The playing and singing is superlative. Jon Anderson's writing just gets better. The epic collaborations between Steve Howe and Jon Anderson continue to evolve and explore new forms, textures and timbres. Squire and White's performances are superior to anything previous, I dare say, and they give the music a nice punch. Wakeman plays with moderation (a good virtue) while blending magnificently with White, Squire, Howe and Anderson and adding color. They play together so incredibly well, each uniquely balancing and inspiring the others. Yes is a *musichine* of unbelievable energy, beauty and complexity.

The album itself seems to me to be of a transitory nature. There's a taste of *Fragile*, a dab of *Topographic*, a dash of *Relayer*, and heaps of new. It's independent, yet familiar.

"Going for the One", the title cut, is a rocker. It's joyful and fun, the kind of tune you hum for days on end and never tire of. "Turn of the Century" is accented with some very nice percussion and shows off the softer side of Yes as does "Wondrous Stories" which features some marvelous Polymoog. "Parallels" is Chris Squire's contribution. It is a powerhouse tune with many exciting moments. The character of the song is reminiscent of Squire's solo album. "Awaken" is the album's tour de force. Far and away my favorite cut among favorites. "Awaken" is a sonic masterpiece that will surely carry you to many places of high wonder where lustrous vistas are on display. There is no one outstanding aspect of "Awaken." It is so well written, arranged, performed and produced, it epitomizes that talent we know as Yes.

Don't just sit there—go get this one.

—John L. Borowicz

Lem Machines Wavefront WF1001

Machines introduces the music of Lem, a small group of Los Angeles based musicians, many of them associated with this magazine from its earliest days.

I have had my own stake in who will make what Rolling Stone some-

what prematurely labelled an album of Cecil and Margoleff's a few years ago, "the first electronic music album of the 1970s." Before hearing Machines, I had mixed hopes and fears that it might be that album. What led me to this belief was the cover art. For it expresses perfectly what this new music might be: futuristic (meaning of the present and not the past, since what is here now always seems to have come from the future when it is first seen); clean; and with both the depth of impressionism and the relentless drive that will carry an abstract hard edge over to a pop audience.

The laurels are still uncut, and we are still waiting for the album which will go beyond Beaver and Krause, but Machines came closer to doing this than anyone may imagine.

First let us get the negatives out of the way. The bulk of the album is built around song form, and the conception of that form evidenced here is as naive and uninspired as the lyrics are awful in both content and actual delivery. The chord changes



go together like going into low gear without synchromesh: clunk, grind, racket. Just to quote the lyrics would be an under-handed satire. Since in some way or other I can't quite put my finger on, the lyrics seem to be bad on purpose, that is, to satirize the awful by being awful, I will save you dear reader the receding mirror effect of direct quotation. Take my word for it, they are not too good.

So far then, no surprises. With the exception of Pink Floyd at their best, and one incredible *joi de vivre* of Larry Graham's, I have never heard a group do rock or blues oriented vocal space material built around synthesizers which wasn't just appalling. In case you're wondering who is included in this dismal band of DC criminals, I don't mean bands who use synthesizers, which by 1977 even includes the Eagles. I mean groups like Curved Air and Robert Mason's Stardrive. Cosmophiles, let us call them.

There are very good reasons why cosmophilic groups and their albums should be so bad. Since I have never seen these reasons listed in put down after put down of this genre, I will briefly discuss them here. First, there is no such thing, obviously, as a cosmo-rock tradition upon which the individual artist can elaborate:

no Duane Eddy, no Bill Haley, no Elvis, and most importantly none of the ongoing processes of editing and refining which happens naturally and inevitably in front of an audience. Not until the advent of polyphonic synthesizers and barely then, has there been even the possibility of live performances. The music was born in the studio, and it was, as a matter of course, a stillbirth. Consequently, each cosmo-rock group has had to begin from the cosmic egg, and it ain't any fun making it all up yourself out there in front of that big recorder, folks, even Stravinsky had Rimsky-Korsakoff as a model. Not since the beginnings of polyphonic music has a single generation of musicians been asked to achieve so much. Consequently, cosmo-rockers have had to borrow, adapt, misuse in most cases, and cover-up their inappropriate origins. For the record, Lem is no exception. The bass lines are all out of post Motown funk and 2nd generation Herbie Hancock, particularly Cima's, which cleverly reproduces rhythmically the inflections of its title, "Scat Cat Kitty." The chord changes are also borrowed, as is the concept of chord changes to begin with. The idiom of the lyrics is, I would guess, about three to four social cuts below Bryce Robbly's own; it is sort of like a YMCA director who opens with "Hey, guys, what's happening anyway?" And from the academic electronic music idiom, comes the refrain "She was a visitor," a direct cop from the piece of the same name by Robert Ashley who currently composes and administrates at the Mills College Tape Center (I refuse to call it by its new fancy name; it was and always will be the Tape Center, dammit; it is the only viable tradition we have when you finally get down to it.). There are two other sources in my view; the first quite obvious to me, is W. Carlos; at two occasions in this record I had a strange thrill as I felt myself on the verge of some further commentary on Timesteps (Headstone) and Sonic Seasonings (Drone Zone).

Neither commentary quite came up to its original, but so what? C. P. E. Bach wasn't Johann either, and after *Rite of Spring* even Stravinsky was only rarely Stravinsky. The last source I mention somewhat timorously, particularly in light of what, so far, has been an apparently hostile review. Either I am suffering acute audio hallucination, or I have just heard little insidiously inside-the-music on-the-run overtone-series-oriented flourishes and furbelos which sound like my first appearance on record, and, unfortunately for me, so far my classiest, namely the 1971 Herbie Hancock record, *Crossings*. I would like to think that in some way I may have contributed to this development, because for me it is the strongest motif on the record. Every pop musician

The Most rugged keyboard system...custom built for you!

You have a need for a system that provides function, size, rugged roadability, for your keyboards at a price you can afford. From this need evolved **Viking Keyboard Systems, Inc.** The Viking people provide a custom packaging concept for Keyboard equipment and accessories, pedal systems for Guitarists, special mixing consoles, and discotech turntable systems. Modular construction and wiring allow fast service and repair. Aircraft electronic shock mounting technology gives your equipment the protection necessary for commercial shipping.



Custom etched panels provide you with controls designed with your needs in mind. One power cord and a single output panel reduce the set up time and trouble of several instruments and modifiers to minutes. Your complete system is powered at the touch of a single switch. Our quality standard is high and displayed by the **Viking Case** in which all your instruments can be repackaged. Ph. 813-522-2118

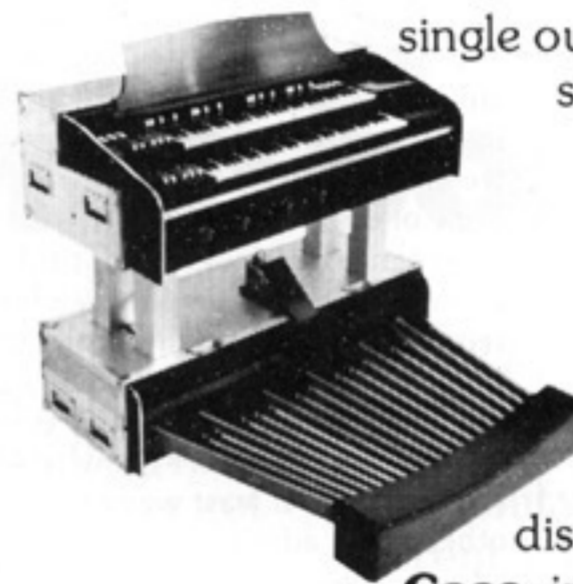

Ph. 813-522-2118



3092 - 47th Avenue North, St. Petersburg, Florida 33714

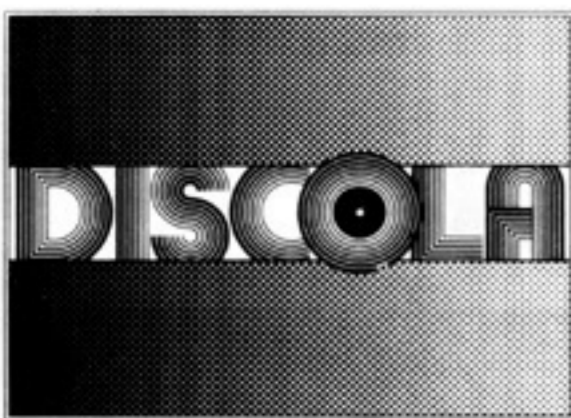

who has desecrated the airwaves with his mini-moog FM patch should study Machines until he can hear the subtle relationship between these airy comments scattered through the record and their more pedestrian texts, because it isn't easy work, it takes a real understanding of synthesizers, and a lot of taste to fly around a melodic, harmonic, and rhythmic ongoing mass with such apparent abandon without upstaging or crossing spiritual mic cords. That Wah-Wah Watson should have been given nearly equal time in this area of music on this record reveals the real extent of the crisis and near self-hatred that Lem, and consequently of all of us who are serious about introducing electronic music into the mainstream of Western music, have to contend with. Believe me, friends Caplan, Cima, Lynner, Robbley, Sofer, and Stubbs, and have no further truck with Wah-Wah; you are being led into the Hollywood holyland by The Witch herself.

This brings me to the last nearly insurmountable obstacle that groups like Lem have to contend with: success. We are at a critical point of no-return; we have certainly alienated the old line avante garde, if you will accept that verbal twist; KPFA and KPFA would lose their license before they would play Machines; even Walter Carlos is anathema. As Morton Sobotnik put it, to my horror, at the last AES, "We are not interested in electronic organs." And he meant *any* synthesizer controlled by keyboards. This hostility surrounds us with more intensity than we imagine. In occasional moments of whimsy I attempt to sell the beautifully designed and irreproachably conceived Eu synthesizer to colleges. One of my scholar non-clients refuses even to look at a synthesizer attached however temporarily to a keyboard; for him this is tight jeans.

And while we have escaped our fathers, we haven't gone anywhere else. Terry Riley's biggest record, a classic on Columbia, never went into royalties; it missed by so much that as of 1975 Columbia had never even bothered to send a royalty statement. *Tangerine Dream* just finished the most successful American tour of an electronic music group ever, and sold about 20,000 records. This wouldn't even pay the full page ads in the trades

taken out to promote the album. My first record, *Beyond the Sun: An Electronic Portrait of Holst's Planets*, got picks in both Billboard and Cashbox, was one of the six final grammy choices for Best Classical for 1976, and it returned exactly one-half of a very modest advance. Many stores refuse to stock electronic music albums; look for the electronic music album section next time you go to a big record store, and you will see what I mean. You either masquerade as a normal or you don't get in the door, buddy, I mean it.

So here we have the real situation, rather than the fantasy putdown. By the most jaded and acute musical standards that my polycultural and record satiated sensibility can bring to bear on *Machines*, Lem fails. Given only the most obscure tradition of their own, and isolated even from that by academic elitism, given no financial support, no audience, and instruments which are still in their infancy, without even a controller to call their own, this is hardly surprising. What is admirable, fantastically to be admired even, is the fact that they have gotten anywhere at all. The only adequate response I can make finally is not a criticism, but a question: where do we go from here?

One thing that is going to be enormously necessary is that we begin admitting where we do come from. When will my fellow synthesists quit sneering at W. Carlos for having had the bad taste to have had one of the two financial successes in our meager tradition? Carlos is a genius, a guide, and one of our resources. Carlos belongs to us, and not to the schmoees at Columbia. For my part I will quit griping about Tomita; at least he has interested some listeners, and he has an unfettered, if bizarre, and for me inexplicable imagination. Secondly, we are going to have to give up the hope of financial success, acceptance, free coke, beautiful girls, and record companies who will return our calls. It is ludicrous to try to sell out so cheap, and then get rejected. Stiff upper lip, they don't love us, and we aren't going to get any airplay. At least we have each other. If we admit it.

I'm not quite through yet. I have a proposal. The situation is analogous to the position of the black musician in the thirties. When the white man began to dig jazz he got other white guys to play it, leaving belligerence, pride, and snootiness of the black man behind. As a consequence black musicians dreamed up bop, the music so fast, pissed-off, and outrageous that even if white musicians could play it, it was years before most of them would even admit that there was any point in trying. Our situation is very much like that: electronic music and

electronic musicians haven't been accepted; Arp Instruments, Inc., has been accepted, and we can go screw ourselves with our weird ideas: *we got a lot of guys can get a real good trumpet sound, and let him hear the break one more time we gotta put in a little something right here, OK?* Tah-duh, instant cliché.

My proposal is that we assume our niggerish stance with a little black pride, and go where the rockers don't dare go, into the intensity of elaborate sequential rhythms, which our new digital machines are quite capable of delivering when programmed, ahem, with a little knowledge which we have and they don't. And that we begin to develop compositional matrices—the structures into which the music goes—from the perspective of our ability to freely associate these rhythms in ways that will screw up even the fastest cop among live bass players. Seventeen bars of a snappy 19/7 followed by 2 bars of 2/2 followed by 19/7 against 4/4. And that we elaborate these structures with the means at hand. Our digital sequencers are repetitive devices, they can be set in motion simultaneously and independently, and will slide against each other then with intriguing and mysterious rhythmic implications. Entirely new harmonic developments will naturally emerge from this. Danny, you are no slouch as a drummer, but there is more important work at hand. Why all the inhibitions of live performance, when what we are creating is sheer electron magic? In this sense I think we should all stop worrying about imitating Terry Riley, who was only relaying his impression of Balinese and Indian music anyway. Certainly imitating Terry Riley, if it comes to that is no worse than imitating rock and roll. And we should stop worrying entirely, Bryce, about presenting music even vaguely comprehensible to an A&R man; we are only bullshitting around anyway until we can show that we have an audience, and we aren't going to get one by trying to *pass*. If you are in love with lyrics, go ahead and work on them, for years if necessary, and present them when you are ready; but there is something more thrilling you have to say right now. Freedom, remember, is just another name for nothing left to lose.

And good luck, Lem, on your next album; and wish me good luck on mine. Writing this review has been a wonderful aside: *Patrick Gleeson's Star Wars* is my last "popular" album. From here on in it is sheer madness, cloud forests, and dying light. And remember, readers, no matter how bad we may sometimes sound, unless you can live on re-runs alone we are all you have. We are the brothers, and the new bloods.

—Pat Gleeson

New Releases

Jan Hammer Group *Melodies*

Nemperor JZ35003

Brad Slocum *Sonic Synsations*

B.A.S. Records 236
D, Red Oak Dr. E., Sunnyvale, Cal.

Donald Knaack *Percussion Music by Duchamp, Cage*

Finnadar SR-9017

Edgard Varèse *The Varèse Album*

Finnadar SR-9018

Patrick Gleeson's *Star Wars*

Mercury SRM-1-1178

Klaus Schulze *Mirage*

Island ILPS-9461 (U.K.)

Go *Go Too*

Arista AB 4138

Peter Baumann *Romance 76*

Virgin P234897

Jean-Michel Jarre *Oxygene*

Polydor

Space *Magic Fly*

United Artists LA 780-G

Automatic Man *Visitors*

Island ILPS-9429

Steve Hillage *Motivation Radio*

Atlantic SC-19144

Brand X *Livestock*

Passport PB-9824

Giorgio *From Here to Eternity*

MBLP 7065

John Mills Cockell *Gateway*

Aubis ANX-1 (Canada)

Patrick Moraz *Out in the Sun*

Import 1014

FINALLY.

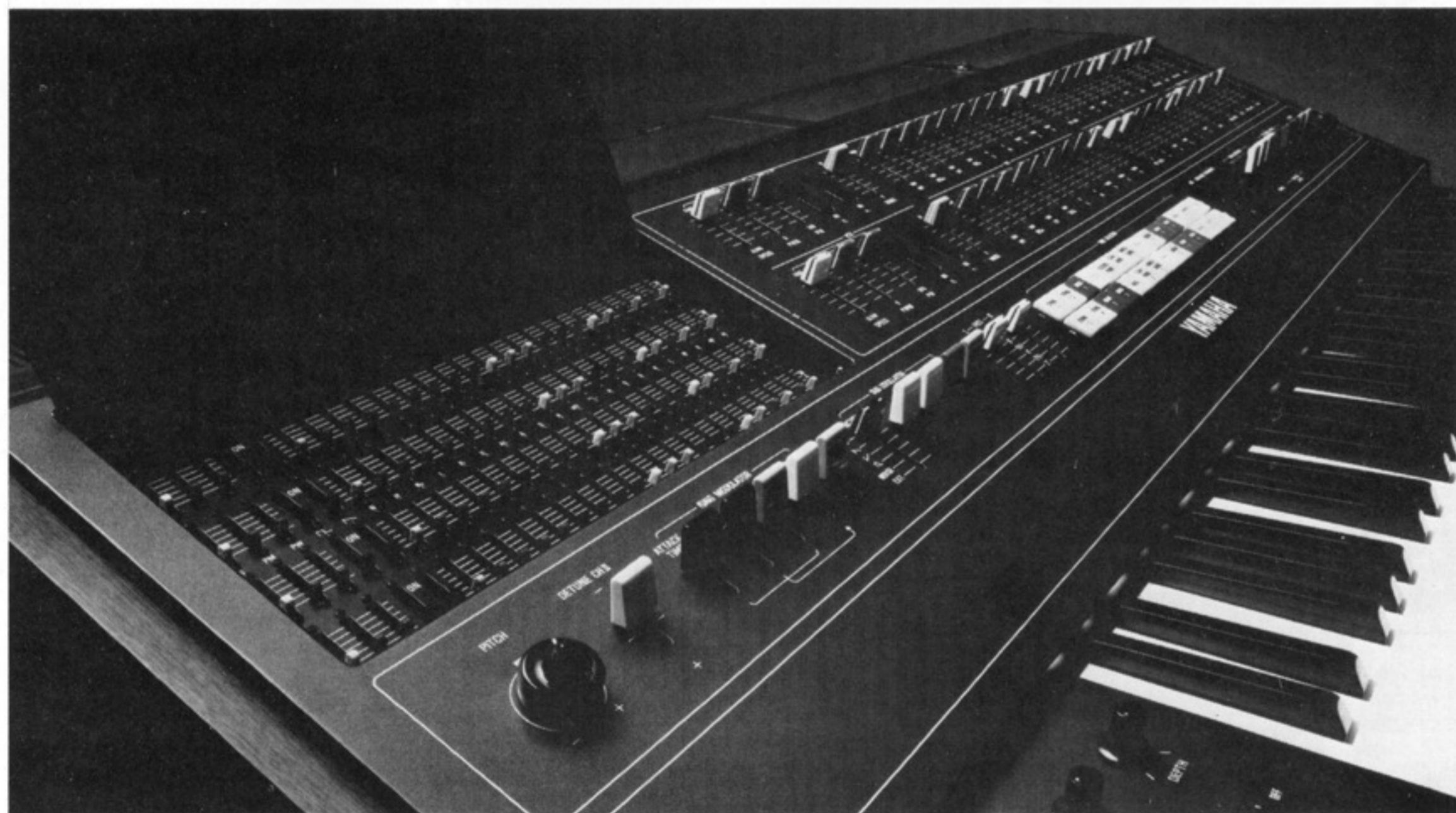

You're a keyboard player, and a good one. That's why you deserve a synthesizer that gives you control. One that responds to your hands, and the technique you've perfected. An instrument that allows and encourages creativity, and lets you play *music*. In short, the all-new Yamaha CS-80 Polyphonic Synthesizer.

The CS-80 is velocity sensitive and pressure sensitive. The volume and brightness, as well as the character of the sound is in your hands.

You have control not only over the notes you play, but also the 22 internal preprogrammed voices, including Strings, Brass, Clavichord, Organ, Electric Piano, Electric Bass and Guitar. The voicings and settings are

A SYNTHESIZER THAT PLAYS AS GOOD AS YOU DO.

easy. But your creativity is never compromised: adjust envelope characteristics, filters and equalization, vibrato, pitch and touch response so that you get your taste, not somebody else's.



YAMAHA

P.O. Box 6600, Buena Park, CA 90622

Four memory banks let you summon the voices *you've* created and preprogrammed.

Because the CS-80 is a polyphonic synthesizer, eight

notes can be played simultaneously, generated by 16 oscillators. And with two channels you get the added flexibility of producing two different voices in any mix you want.

You'd expect a one-of-a-kind synthesizer to come from the people who've been perfecting musical instruments for nearly a century. Write for a free brochure. Or try a first: play *music* on a polyphonic synthesizer. The CS-80. Or try the CS-60, or the CS-50. They're all polyphonic, and they're all at your Yamaha dealer.

State of the art from polyfusion



Meet the Polyfusion 2050 Series, a new line of ultra-reliable synthesizer keyboards. Each of the four new models carries a 5-Year pitch contact warranty in addition to the standard 1-Year warranty on the entire unit. Choose from a wide variety of features including pressure and/or velocity sensitivity, "Micro-Touch" octave transpose, selectable logarithmic/linear glide, one and two voice, and an X-Y Joystick controller.

The **2050 Series Keyboards** are totally compatible with all major synthesizers through use of the optional 2064 Keyboard Interface. The interface contains a regulated power supply and provides all necessary outputs including "S-Trigger" for use with Moog equipment.

With great concern for quality, and employment of the latest "State-of-the-Art" technology, we believe these keyboards are unmatched in the industry. **For complete, illustrated specification sheets and price information write:**

polyfusion

160 Sugg Road, Buffalo, New York, 14225

This exclusive interview was conducted in Tokyo during August 1977. Isao Tomita was asked about his motivation for realising existing scores on synthesizer. His answer does not reveal the crass personality imagined by those who see his records as a misuse of the synthesizer or as a mistreatment of "Great" music. Instead, it shows a conceptual relationship to his background in visual art and his self-envisioned position as a "creative filter" for musical tradition. Also among the topics in this interview are the technical means by which Tomita realises his string ensemble sound as well as effective dynamic changes.

By Max Von Kunstdorf

Max Von Kunstdorf: Well, you are now one of the best known artists of the electronic synthesizer in the world. I understand that you composed many works for conventional orchestra before you came to electronic music. What at first attracted you to using synthesizers?

Isao Tomita: I studied music not at a regular music academy, but took private lessons and training in harmony, counterpoint, orchestration, etc. I was majoring in aesthetics and the history of art at the University as a regular student. I have had, however, an unsolved question and doubt about music from those days.

If I may compare with painting—in painting the artist is free to use whatever color or material he may choose. In other words the medium for his expression on the canvas is free and unlimited. There are plenty and abundant mediums, whereas in music we have had to use very limited means: the musical instruments. In painting one could use unlimited variety in color, but in music only certain numbers of timbres were available to express composers' ideas and feelings.

We see two paintings: for instance one by Paul Cezanne, the other work by Van Gogh. There may be some similar points, but the colors and the expression are quite different. But in music, for instance we compare a symphony of Beethoven's and a symphony of Debussy's and the main sources of the sounds are the same. Both composers have used flute, oboe, clarinet, faggot, trumpet, horn, trombone and then comes the group of stringed instruments. The two composers' symphonies are quite different but the musical instruments they used were the same or almost the same.

I'm sure composers were not satisfied. They wanted to have their own original

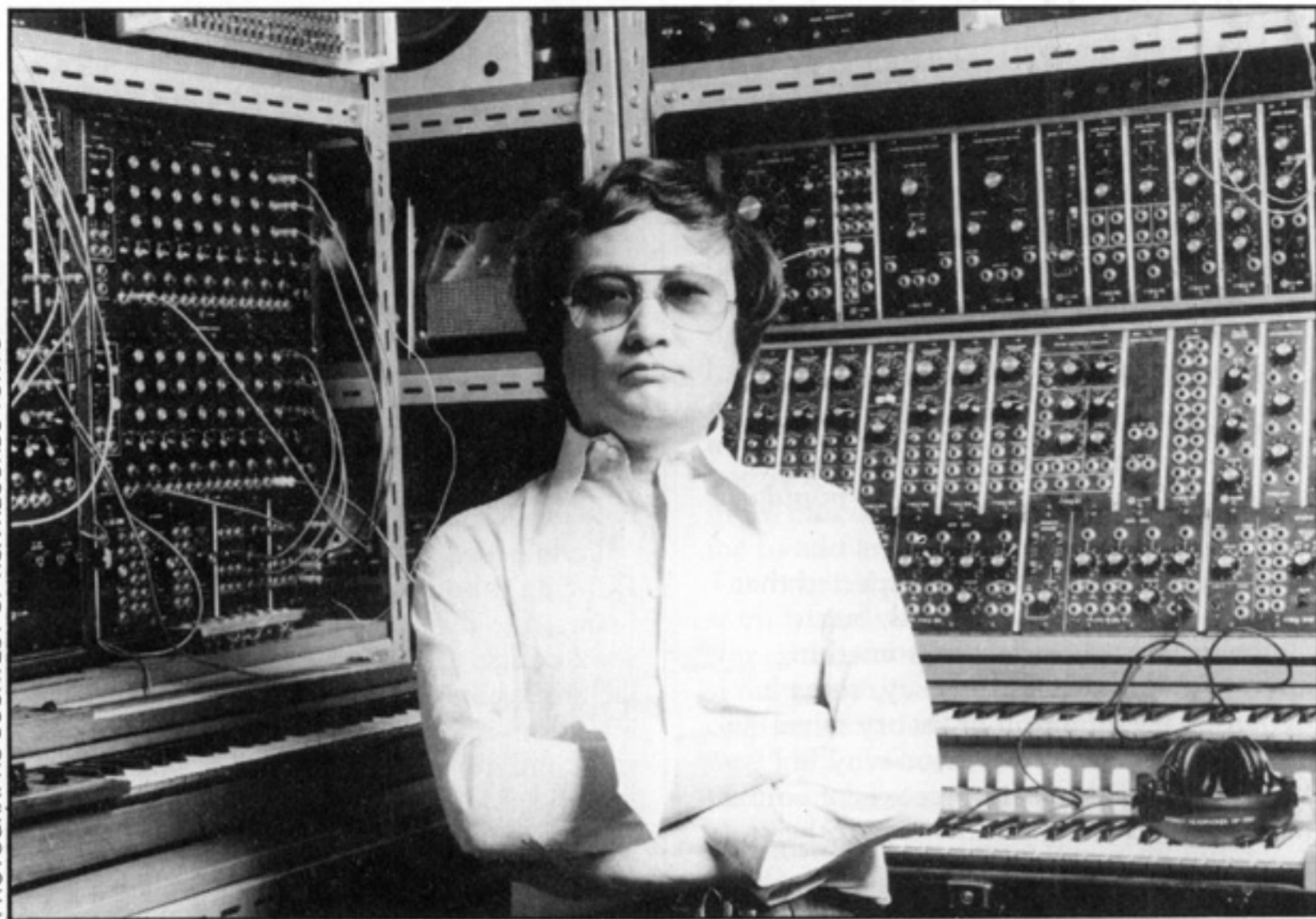

PHOTOGRAPHS COURTESY OF RCA RECORDS TOKYO

Isao Tomita

“Art is art when it is appreciated by someone.”

Tokyo, August 1977.

medium with which to express their feelings through music but they were forced to use the standard sources of sounds.

My doubt was, should music be always like this? Couldn't it get some new source of sound beyond existing musical instruments? That was my doubt and at the same time my dream. After my study of music I started my career as a musician/composer and I have composed several works for movies, numerous pieces for TV shows, dramas, and music for the theaters but never was I satisfied. I had to fight with myself as my musical ideas leaped far away; far beyond the given sources of music that are the instruments in the orchestra, but I had to compromise and so I was waiting for happiness. I was waiting for some instrument which could break this limitation.

In 1969 I happened to listen to a record titled "Switched On Bach" which opened a new world to me and triggered a revolution in my musical life. At that time I saw on the jacket of the record, behind Bach, a synthesizer, which is to say the palette of sound. For the first time I discovered that the synthesizer is not an instrument to compose music by using the sounds of existing instruments, but is a new instrument or a new machine which creates unlimited sound sources.

Kunstdorf: You have long experience composing for conventional instruments—how many years have you been composing these kinds of works?

Tomita: Well it was I guess in 1951 I began to compose to make a living and I did pretty well. I had graduated from the University in 1955—that means for four years prior I had

TOMITA

been composing as a professional composer. After graduation I just continued my career as a composer, so from 1951 until 1969 I was composing for conventional orchestras. I then discovered the synthesizer and changed from conventional instruments to electronic music, so literally my history of synthesizer is from 1970 till 1977, just eight years.

Kunstdorf: *What was your expectation when "Snowflakes Are Dancing" was released? Was it expected to be as popular as it was?*

Tomita: Of course I never expected that so many records would be sold, but to tell the truth I was expecting something different and I had, if I may say, some revolutionary intention or theory when making this music. The reason why I chose Debussy as my first piece is of course that I liked his work but there are other reasons, too.

So, theoretically, the synthesizer can create any kind of sound—that means a free source of sound with which to express. But to be honest with you, before I compose some new piece denying all of the rules and aesthetic regulations of existing musical instruments just to build up new worlds, I thought I'd better go along with the historical development of music and musical instruments and then from there gradually evolve the timbre of the sound or the organization of the sounds. In "Snowflakes Are Dancing" I don't deny the sounds of Debussy's music, rather I agreed with them—but from there on I tried to create my own sound source and so my intention was to let the audience compare Debussy's or other people's sound using conventional instruments to my sound using electronic synthesizer.

As you know, Walter Carlos' emphasis when realizing Debussy was on the level of mere description and depicting, but my intention was to make a contrast to the work of Walter Carlos. My emphasis was more on the timbre or color of the music. That was my first step: to break the limitations of the source for music using Debussy's composition—and I'm sure I broke that: the limitation of the timbre. Of course, seen from today, it's not quite satisfactory to me but at that time I'm sure I created something new. As you see now, it was kind of an experiment for me. I experimented with my theory to create first the color of the sound which the conventional instruments never could bring out, and so I don't think that I failed.

However, I don't want to be misunderstood concerning the acoustic instruments existing today in Europe, in Asia or anywhere in the world that are used to create artistic music. The instruments which exist today are the most refined and I don't deny, I can't deny, the beauty of the

sounds that come from those instruments and I don't think electric music ever should deny these; so you create with the synthesizer the sound of violin or the sound of piano or the sound of harp—why not? They are not bad sounds at all; they are beautiful sounds so I don't deny them at all. The intention of my playing was that with a synthesizer I could break the limitations of such instruments and go into the unlimited world, and I started with the color of the sound, and the result was this piece. But we are going beyond even the color; we are going to the form of music composition and finding new aesthetic rules and creating a new world of music.

I composed Debussy's "Snowflakes Are Dancing" about one and one half years after I started to use synthesizer for composition, so of course seen from today there are points lacking technically. But as a whole, my intention, my direction . . . I think I was right and my work deserves the popularity and the plaudits of the music lovers.

Kunstdorf: *Why do you think you have become popular while others pursuing similar ideas are obscure?*

Tomita: It is difficult or impossible to answer this question because I cannot explain about other artists. I really don't know very much. All that I can do is explain

"...my intention was to make a contrast to the work of Walter Carlos."

about myself and about my own work to an extent, not about the other composers' work, but there is one thing I can tell you: that music is not philosophy—music must have philosophy at its base. Any composer has his or her own philosophy but music is art—music is not philosophy itself. I think this is a very important point.

Kunstdorf: *Are you referring to the music which one cannot enjoy without explanation?*

Tomita: Oh yes, something like that. Often we hear through radios some kind of

modern music which represents the composer's design or ideas but not the composer's music itself. The composer's philosophy may be orally explained together with the pieces so that the listener can use a little bit of his imagination, but still I do not think that it's music. That is something else before it becomes music so it's not music to my thinking. It may be important for research and for the development of music. We have to go through such stages. I don't deny this either. I respect those composers who research, scientifically and philosophically; they are part of music. I really sincerely respect them very much but as long as they don't become music, people will not be able to enjoy them; if people do not enjoy them they will not be popular.

As far as I am concerned, music is of course an art and art must be something deeply related to the human being. It means that in addition to the kind of machine or materials we may use to make art there must be the human being, and the instrument is nothing but the means to express or to convey the feeling of the human being.

. . . Of course the music shouldn't be influenced by commercialism and the commercial music shouldn't be the center of music—but the so-called advanced electronic musicians say if the audience is not satisfied, or if they leave, or if they don't come, "well, you are wrong, you don't understand my advanced music so I don't care about you, and you may leave and I am going to do my work alone," so it's very subjective. They even deny the audience. On the other hand, some popular composers are even afraid of the audience leaving. They are very much concerned with the reaction of the audience, which is the best criticism by which to analyze their work again and to make corrections so that that will serve their progress in the next work. I suppose that in a concert of popular work, if the audience all leaves, the composer will be very unhappy and he will never think that his work was successful. So the audience is the barometer of success. I don't mean material success, but artistic success—and I do not believe that art exists without the audience. Art is art when it is appreciated by someone. It is not something that is absolute.

Kunstdorf: *If we may go into the details of your work, I would like to ask if the looseness with which you interpret pre-existing scores is designed to attract a popular audience or if there is some other reason?*

Tomita: As I said before, it was my creative attempt; I had to try to create more color for the audience. My artistic desire forced me to do so. So you see that I did not interpret the pre-existing scores in order to make it popular, but I tried to create my own tone color for them. Maybe unconsciously the mass were dreaming the same sound-color as I was, so it matched. That can be the only explanation why my



ILLUSTRATION BY ADRIENNE MARIE PICCHI

synthesizer music, electric music, made them happy and then it became popular. So the main purpose was my inner desire, my artistic desire; it didn't come from any commercial or business reason. I chose Debussy's work because I love Debussy's work and with a new instrument like the synthesizer, I could create any kind of timbre that I wanted, and I recreated my own work with Debussy's work. As you know, Debussy's original score was for piano, and as I was listening to this piano piece I was hearing it with my own timbre

or sound color, so with my dream I realized it and the synthesizer gave me the possibility of this realization.

So anyway, RCA was interested in this piece and gave me a contract to write more music and it became a series. I have often been asked why I arrange existing scores with synthesizers and why I do not compose my original compositions. I have a contract with RCA so I write electric music on existing scores. Although I am very much interested in working this way, and I am happy with this contract and will gladly

continue it, this is not the whole of my art—this is a part of my art. Of course, I can and I will compose my own compositions, but since the synthesizer came I have brought my dream and my imagination to existing music.

For instance my new work, "The Unanswered Question." People say that this piece is monotonous and how could you love this piece, but since I once listened to it on the radio some years back, the piece fascinated me. I didn't listen as the radio sounded, but I added my timbre to it. I added my sounds to this and I was very happy and I enjoyed it immensely. So the more monotony there is, the more room for me to add and to create my own work! The original music has, for instance, trumpet sounds and violin sounds, but to my ears it's something different. I always hear the music simultaneously interpreted by adding my own imagination and it's quite different: a new kind of sound which none of the traditional instruments could produce.

Kunstdorf: We know that your latest work, "The Planets" by Holtz is another hit and also one of your most popular pieces. But has the publishing controversy with the Gustolf Holtz estate over "The Planets" altered your thinking on this point at all?

Tomita: My answer is there is no influence—it will not influence my creation at all. I was aware of it, so before I began I told RCA in New York that I could only start my work when they had legally solved this problem. Then I received an answer from RCA that "everything is okay and you may just go on." The trouble was not between the Holtz estate and me, but between my publisher, RCA, and the Holtz estate, so I really don't know the details very much. I only know there was some trouble but I don't know what the trouble was.

In this kind of situation, music and, for instance, painting are different. There is one painting, one masterpiece, say. If another painter adds color or a line to this original painting, it is destroyed. But it is quite different with music. In music there may be one original score, but there may be thousands of scores of the same composition, and there will be hundreds and thousands of other composers and arrangers who may rearrange the original music; who may add something to the original, who may extract something from it. Whatever changes the other people may make, still the original score exists without being changed, and the greater the original score, the more perfectly it will be preserved, and everyone will recognize the original one against the augmented or arranged ones. I don't think it's a problem which endangers or destroys the original score.

So this is my general idea about the composition and the right of arranging or performing. If one plays a score, each player will interpret it differently and each conductor performs it differently, and you

TOMITA

cannot limit or tell the conductor exactly how the original composer imagined it. The music score itself is loose. It just indicates roughly how the music is, but all the delicate things will not be the same as the original composer had in mind because even he cannot write it down. In general, I do not believe that a music score cannot be touched or rearranged.

Kunstdorf: *You have already released several records which have sold all over the world, and I'm sure you get many letters and hear many comments and many responses about them. Do you feel there are any aspects of your work that are insufficiently appreciated?*

Tomita: Well, there has not been anything to specify about the appreciation of my works. They generally appreciate even some detailed point that I wanted to be appreciated, so I may say they properly appreciated my work. But there is a very interesting story. As I published the first and second works, the criticism came from professionals, mostly in Japan. I cannot mention them by name here, but they are some very prominent modernists who have even had the experience to work with electronic music. Their criticism was "Tomita's records are not human and all the sounds he composes sound like a machine; it is machine music but not human music." I was shocked to get this criticism. I couldn't understand why they received my work as sounds from a machine. Of course it was sound from a machine but on the contrary, my intention was to create as much as possible sounds related to human beings.

But I don't think these public criticisms have influenced the proper and honest appreciation of the music lovers. If they had said that I needed more improvement in the technique and handling of the instrument, or we need more improvement in the synthesizer itself, I am sure I would agree with them. But their point was quite wrong. Whether we use electricity or not doesn't matter. It's an expression of the human being and my music is as human as other music performed by conventional instruments. Why is music produced through electricity unnatural? I believe it is as natural as other sounds. As you know, electricity is an energy which flows quite naturally just like wind blows in the air and water runs in the stream. These phenomena are natural and so is electricity. So an art which uses electricity is as natural as other kinds of music.

From the first day of the earth we have had thunder and lightning in the sky. When I hear thunder in the sky, I think it is a sound of electronics; so it is a source of material to compose electric music which has existed since the first day of the earth. Fire had been taken into mankind's life very

early. It has a long history, but electricity existed from the early days just like fire, only the history of using this energy is much shorter. Today in our environment we cannot live without electricity; electricity is in our life. Light, air conditioning, stoves, refrigerators, radio, TV . . . well, you name it. Our environment is full of electricity. In a way maybe it replaces other kinds of natural energy.

There are people who criticized "The Planets" because there were sounds with which they were not familiar, never having been used in classical or conventional music, and they sounded like machine noise. Those people's criticism is that these sounds are not

not? As long as they all come from the same speaker they are all musical sounds. The capability of a speaker for musical expression is very powerful and highly developed.

Kunstdorf: *Generally, words of praise rarely reach your ears, but negative criticism will reach your ears very quickly. I still want to know if there was any particular work of yours which was unduly praised or unduly criticized.*

Tomita: Well, yes. If I may say, Stravinsky's "Firebird," as far as I am concerned, was a pretty good work. Anyway I was satisfied to write that piece. I mean, not to write but to compose that



PHOTOGRAPH COURTESY OF BEARSVILLE RECORDS

Utopians meet Tomita: *Todd Rundgren (l.) and Roger Powell (r.) met Isao Tomita in his Tokyo studio when in Japan earlier this year for Utopia's premier tour of Japan.*

music—not musical sounds. Accordingly, my work "The Planets" was not pure music.

But as you know, the main part of the violin, the body, is for resonance, the sound comes from the string, and the resonant cavity or body will amplify the sound, which is sent to the ear with the vibration of the air. The same thing can be said of the piano; the hammer will strike the string and the vibration of the string will be resonated and amplified by the piano body, and will go into the ear and then to the human being. With synthesizers it is the speaker which sends the sound to the ear, so the speaker is a very important part of the musical instrument, and any sounds—all sounds—which come from speakers, as far as I am concerned, are the sound material for music. How can you say that from here to there is musical sound and from there to there is

piece. I liked it, but the statistics from my publisher said it did not sell very well, especially in the United States. That was something different from my expectations.

Kunstdorf: *Oh, that's strange. In Germany "The Firebird" was very popular and people liked it very much, and I thought it also sold well in the United States.*

Tomita: Unfortunately this was not the case. I still believe "Firebird" was done pretty well.

Kunstdorf: *What are your future plans? Might they include any live performances or original compositions?*

Tomita: Yes, of course, I am going to compose my original music, for which I have several ideas and plans already. Among them, the first few that I want to compose are based on Japanese stories and fairy tales.

I am still, of course, preparing for this. My first original composition—I don't know when I can start it—is based on the old Japanese story, "Miminashi Hoichi" or "Hoichi the Earless." If I may translate into English, Hoichi is the name of a musician who played Bewah (a Japanese stringed instrument) and Miminashi means "Earless." Hoichi was blind but was a skillful Bewah player. The story is related by a ghost. I am going to compose this in four channels. I like to compose for four channels. I have always done this and I believe that electronic music must be heard on a four channel system because you can move your sound image in space. I believe the future music must be at least in four channels.

The story "Miminashi Hoichi" involves the musician Hoichi in real life, and every night he's invited to the Heike family military division to play for the officers. This was in fact not the real world but was a group of ghosts in the graveyard. So he commutes between the real world and the world of the ghost. So I'm going to use the actual space to move the sound image from one point to another point, which I'm sure will be very interesting.

As far as live performance is concerned, I used to do some concerts in European countries and in Japan, but not in the United States. But I don't think I shall do it again in the future because I believe the synthesizer basically is not an instrument for live performance, because to create a sound you take time. If we do it quickly we cannot make good music. I say this of the electronic synthesizers of today. The hardware is constantly making improvements and who knows, in the future they may offer the possibility for the performer to instantly create the sound that he wishes. Then live performance may be possible, but as far as today's instrument is concerned, it is not very effective and not very interesting. That's the reason why I'm not planning to give any live performances in the near future.

Kunstdorf: *Where do present day synthesizers need improvement?*

Tomita: It is hard for me to point out all the details which should be improved in today's synthesizers. The first thing is, you see, I can handle synthesizers pretty well, but there are still many things that I have not mastered. I have to improve my technique first so that I am in a position to control the synthesizer perfectly. So my answer is, it is me to be improved, not the synthesizer. Of course, there are things which I often wish were a little bit different.

Kunstdorf: *What are they? What modules, and what points should be improved?*

Tomita: You see, I wish that I could patch the different modules in a short time. It takes too long when I have a sound image in my brain and then I search to pull out that sound image in my brain and then I search to pull out that sound from the synthesizer. I have to patch it this way and that way,

and that way and this way. Sometimes it takes half an hour, and often during that half an hour I lose my own sound image and I don't know what I'm looking for, so I am disappointed. I don't know, maybe if my technique is perfect someday I will be able to create that sound or patch with all the different modules in a very short time, but at present for me it takes too much time. But please do not misunderstand me. I don't mean to make a synthesizer like an organ or piano where you just switch it. Only certain given sounds are there and you can't create any further. I don't mean that at all. It may be convenient for live performance on the stage but for my kind of composition, the limitations of the variety of sounds is fatal.

Kunstdorf: *Will you describe for our readers the technical means of producing your very good string sounds? If it's not your secret, we'd like to know about it.*

Tomita: Well, I can tell you. It is my work, but I don't think I should keep it a secret. It's very time-consuming work. Until I invented this technique I had experimented with many things for a long period. First, I took the signal which came from the oscillator and then gave it some treatment, and then I mixed that together with other oscillators, but still the sound didn't sound like natural strings. It was still very much like the sound of an oscillator.

Suppose we hear the sound of ten violins at the same time playing the same note; say they play the note A. When we analyze, each violin plays the same A, that's true, but the musical effect is different. Each violin is different because each violin has a different resonant body and so it produces a different A. So ten different A's will be summed up and that creates some very special, beautiful sounds. Suppose if, well it's not possible but suppose if we span ten strings on our violin and we play A at the same time on ten strings; this A is not the same A which comes from ten violins because with the latter situation the resonance is of one kind but the first is a summary of ten kinds.

It's a problem of the resonant effect. In my work I use a filter for a resonant box, so when I play a note on one violin I use a certain filter setting and when the same note is played on the next violin I use another filter setting.

Kunstdorf: *Aren't you using a phase shifter?*

Tomita: Oh yes, I use a phase shifter, but before that I use various filters to treat the signal. Of course I use echo machines, phase shifters and delay, but using echo machines and audio delay alone will sound very mechanical. I mean, you can feel that it is not very natural. It's mechanically changed. So the main thing is to give the effect of different violins by using different filter settings for the resonant box. So I play a violin once and then I play the same melody again with a delicate, slight change of filter

and I pile them up say ten times to make one sound. The sum of this if you mix them up becomes a really beautiful violin ensemble sound.

Also we have many other techniques or very delicate treatments I use. One of them is accent or how to give accent. That is also very difficult. I use some special triggers to do this and that is also not easy. Technically it's not easy to perform this on the keyboard. As we all know, even if you play a scale there are different very delicate accents. That's natural and you analyze on which note an accent comes. Also there are a variety of accents; some are weaker, some are stronger, but when I compose I make two or three kinds of accents and I use this for expression. If you play a scale without any accent, then it sounds like a machine. It doesn't sound like a human being would have played it. So I have researched and I have a library I have made of all of them: the accents, and how many and where and what kind. So you see what time consuming work it is just to create a very short, simple note or short melody. In other words, my effort is to give expression to each signal which comes out from the oscillator.

Another thing which I may mention is when you change from *forte* to *piano*, changing the volume is not enough. Also the timbre changes, so you need to treat it with the VCF together with the VCA, then you can get the real effect. And that is not easy. You have to experiment and experiment and you learn through the experiments all the delicate differences and delicate techniques and how to use them. I work in this way to create, for instance, sixteen violins playing, and it sounds very natural to the listeners. But the point is that it is not quite the same as the real sixteen violin ensemble. Still it's different. I hope the sounds created by synthesizer are better than the real violin ensemble sound.

You see, we paint, we make a sketch of nature, we make a sketch of flowers or some street scenes—but it is not that the painter sketches to express on the canvas that which will look real, but in his sketch, his aesthetic creativity works and as art work it is not the same as real nature. There is the painter's ideal and aesthetic sense in his painting, so although the sketch is of a real scene which exists, the scene is nothing but the model of his creation.

So the sound that comes from the real violin ensemble is a model. The sixteen violin ensemble melody which I create with the synthesizer is something created by me to my ideal. Though I use the real ensemble as model it is not the same. People say that it is not right to imitate existing musical instruments, but I don't agree with them. The existing musical instruments are the instruments which produce the finest sounds. Why shouldn't we use them for our model? I don't know whether it is proper that I compare my musical process with painting, but I hope you understand it, and I believe it is still creation. ~~~~

Bridge Over Troubled Whales

by Will Jackson

Part One

Ecology: The Last Fad

The whale and dolphin movement has been steadily accelerating for two years, its most sensational moment being the Greenpeace V encounter with the Soviet whaling fleet on the high seas in 1975. Since that time, "Cetacea" has been explored and exploited by nearly every entertainment and media form in Western society, often times using the image and spirit of the cetacean family for personal and corporate gain. For instance, I wonder how much of the box office from "Orca" or "Day of the Dolphin" went back into the struggle to secure a lasting peace for these creatures. What this says about our future on the planet is questionable. The scientific prognosis seems grim in terms of the quality—and the quantity—of life. From space scientist Carl Sagan to the kindergartener, to the little old lady next door the feeling appears universal: the loss of the whale and dolphin would herald the beginning of the New Dark Age, at best. Yet there is emerging from certain factions of the oceans science community a new perspective which is based, interestingly enough, on the principle of synchronicity.

The suggestion is that ecological "activism" and especially the whale "conspiracy" is raising questions which go beyond our concern for the whale—questions about the proliferation of nuclear waste and its "storage" in deep ocean waters; about the effects of supertanker transport and the degradation of harbors and waterways; about the depletion of fish stocks and the poisoning of world's prime fishing grounds. Even if only for economic reasons, people are beginning to look and listen to the many warning signals. And while success in the whale conspiracy has yet to be achieved, this concentration of focus is working in concert with other elements of world culture to bring into reality an equitable means of managing ocean industry. This means a new world consciousness—a new bottom line in environmental thought and practice. The suggestion, as verbalized by Dr. Sidney Holtz of the UN Food and Agriculture Research Group, goes further to hint cautiously of world government being the natural, inevitable outcome of ocean legisla-

tion arising from activist pressures. These are no idle words—the source is of the highest level. The whale fad, as self-serving as it is, will only bring deliverance that much sooner; for our culture requires fadism to achieve further progress. But how does this relate to music? To the musician?

A three-day musical environmental festival happened in April of this year which addressed this question quite dramatically. Taking place in Tokyo's Harumi Dome and Trade Center, the international affair hosted by Japanese environmental groups under the Dolphin Project Japan banner offered a rare and superlative program—the movement's most ambitious and enigmatic endeavor to date. It was formally titled: *The Seas Must Live—Japan Celebrates the Whale and Dolphin*. The purpose was to isolate the Japanese whaling companies from the public—through music—and exhibits about the whales and dolphins—and Japan's Minamata mercury-poisoning problem. International unity was the goal. The Japanese public, press and scientific community were impressed because the event was organized from an anti-boycott, pro-worker position. The musicians, especially the Japanese, loved it because it was the first music benefit ever held in Japan. For the San Francisco production staff, however, the final weeks leading to departure were fraught with anxiety and poverty. Volunteers and visiting Japanese promoters slept on the floor and derived nutrition from bullion cubes and packets of non-dairy creamer. When it was realized late in the preparations that virtually none of the powerful American environmental organizations were going to come through on their promised support, the production went into a tailspin. It seemed almost as if a concerted effort was being made to prevent its occurrence. But the elusive 747 charter flight came together in the final hours, thanks primarily to the staunch conviction of the Tokyo contingent.

With all their capital already in escrow, they weren't about to see a year's effort in defeat. The Americans represented not only a crucial force and influence for the whales, but a capital investment in the wedding of Japan's commercial music industry with the environmental cause.

The Americans (all of whom were not American) saw the excursion as a real chance to: 1) Save the whales and promote goodwill; 2) Make a political, professional or personal statement; 3) Make some good music with

the Japanese; 4) Expand their scope of understanding; 5) Expand their market potential; 6) Buy equipment cheap; 7) Eat free meals and stay in a nice hotel full of freaks; 8) All of the above.

Cheers and 115 skipped heartbeats greeted the April 6 lift-off, but sobering thoughts subdued the flying cocktail party as we glided into the gray monochrome chaos of Tokyo. Insurmountable obstacles awaited us there, but the faith and steadfastness of Dolphin Project founders Ric O'Feldman and Fred Neil was to see us through.

With producers Leo Makota, Tom Campbell and Akio Itoh, and coordinators Mark Lavelle, Noriko Abe and Masatoshi Iwanaga, they set bravely to the task of presenting in one giant musical package Jackson Browne, Richie Havens, Stuff, John Sebastian, Paul Winter Consort, Odetta, Eric Anderson, Mimi Farina, Danny O'Keefe, Country Joe McDonald, Terry Reid, J.D. Souther, Lonnie Mack, Harvey Brooks, Peter Childs, Louisiana Red and many more. The Japanese would offer the unpredictable Shigeru Izumiya, The Street Fighting Men, The Sunset Gang and others—among the most popular musicians in the Land of the Rising Sun. As it turned out, they all found inspiration in this impossible alchemy, some even singing their songs in the other's language. These were among the most sensitive moments. John Sebastian's "goodtime" harmonica and Richie Havens' strong voice entranced the crowds, while Paul Winter's music brought tears to many eyes. And when Stuff arose from their playing stools and kicked out the jams, the house came down in classic style.

But what does all this have to do with synthesizers? With electronic music, and all that esoteric stuff?

There was one synthesizer there, to be sure; a Serge Systems model played in collaboration with the acoustic assemblage of Stefan Weisser, all under the pseudonym TO. Through these instruments (and others), Stefan and I sought to express in non-verbal human terms our interpretation of the form of consciousness that is the inspiration for the song of the whale. In this, our musical approach—the information we had to offer—was most similar to that of the Consort. But we did not share the stage with these artists. The producers needed "top-draw," naturally, to make the event pay. Suffice it to say that even the Consort was in this context considered to be a "zero-draw" act. Certainly, we were not of the popularity to

"The Seas Must Live!"/Japan Benefit.

logically be included in the concert proper. But as our form is one concerned with the environment as integral to the being, exploring the integration through sound, this actually worked to our advantage. Located in a very large concrete and glass space in the exhibition hall adjoining the concert dome, we were classified as an "interspecies communication exhibit," although there were no other species in sight. There was a respectable number of humans, however, enjoying the "free music" and listening to the sounds echo in the acoustically underwater-like room. Interpreters were there to help us explain our presence translating a "poem" we wished to display in Japanese over our set:

"Projection of the form and function of whale and dolphin language—

Having no hands, hence no "objects"

Having no permanent residence

Having no monetary system of exchange

Having no territorial boundaries—

Having personal relationship

Having community consciousness

Having total access to their environment

The process of communication of consciousness

Information with sonic means—

Expanding our awareness of air as a conduit

for sound, as water is for whales and dolphins

i.e.—density, temperature, gravity, current, light-

image

There can be no doubt that whales and dolphins

are in balance with their environment—

Developing sensitivity of balance

by focusing on the interaction and interrelation

of vibrations—

in water or air—

in mind and body."

Part Two

The Whale-Gate Tapes

Following are excerpts from taped interviews and meetings with artists and environmentalists during their seven-day work experience in Tokyo, "waging peace" against the industry. The tapes were gathered by Scoop Nisker of FM radio station KSAN in San Francisco, commentator for "The Last News Show" wherein the advice is given: "If you don't like the news, go out and make some of your own".

Departure from San Francisco

John Sebastian: As musicians, we're starting our international approach by playing together. And this is something that hasn't happened in Japan before, because American acts tend to come over, give their performance and never actually enter into any kind of music with the Japanese.

Scoop Nisker: Do you see any parallel between this and Woodstock?

John: Only in the sense that something more exciting than a normal concert is happening here. But I think that what we're

doing now is much more worthwhile than Woodstock ever was, even though that in some ways had aspects of a social revolution that was suddenly out in the open. This is something that we're doing for ourselves, because the whale, as I'm sure somebody has already said, is the tip of the iceberg. What we're attempting to do is to begin to save ourselves.

Scoop Nisker: John, what was your first contact with marine mammals?

John: Well, I guess it was at five years old when I was crossing the ocean with my father—he's a musician also, and used to do tours in Europe—and I would end up on boats frequently, watching dolphins at the front of the ship.

Byrd Baker . . . founder of the Mendocino Whale War: This is really the way it's gonna come down—to right a great wrong people get involved with their presence, and it's going to be decided in Japan the day that they stop killing the whales just like it's going to be . . . maybe . . . maybe there'll be another great happening and we'll all go to Russia together.

Scott McVay, author: I've heard some criticism of this project in that it's another form of "ecological imperialism"—American ecologists coming over and telling the Japanese what they should do.

To the best of my understanding, this was all arranged at the invitation of Japanese in Japan. And it's at their invitation and as their guests that all of the persons associated with this project are making this trip.

Tokyo Press Conference, Den Harumi Hotel, April 6, 1977

Mark Lavelle, coordinator of the Dolphin Project: What the Japanese people are doing by holding "The Seas Must Live" as the kickoff point in a consideration from an international point of view of ocean problems, is creating a great effect among American environmental groups who have been concerned with the whale problem. Most of the major American environmental organizations, which have been trying to solve the whale problem through a boycott of Japanese products, are now rethinking that kind of tactic and instead, looking to cooperate together with Japanese environmental and anti-pollution groups to solve not only this particular ocean problem, but other common ocean problems.

Odetta: . . . For me it makes me feel all kinds of necessary. And it is for all of us a concern whether we dance, stand on our head or tap-toe, un, (laughs over attempted translation) we are cousins on this earth, depending upon this earth, a freak or normal (laughs). And it is that far vision of far away,

My feeling is that we truly are our brothers' keepers, and we truly do have responsibility for and towards each other; and wherever improvement of life happens or tries to happen, just call me.

(loud cheers)

Richie Havens: Thank you very much. I'm very, very proud to be a part of something that is happening for the first time in history, and I'm sure not for the last time. My involvement here is as part entertainer and part of an exhibit that came from America called "A Right To Live." This exhibit was put together by Mr. Michael Sandlofer, myself and several other people who volunteered their services in order to bring about this exhibit.

This exhibit is subtitled "An Historical Analysis of Yankee Whales and Whaling." American history. Michael and I both feel that it is necessary for children around the world to find out immediately, if not sooner, that their world and our world is slowly diminishing because of our misunderstanding of our environment, and the taking out of our own personalities on the earth—we take it out on the earth in some way, however we live. What I mean by personality is that there are differences between cultures, and I refer to these as personalities. And I also feel that these personalities are relative, being that we all live off the air that surrounds the earth, and the water that comes to the earth, and the food that is grown on the earth. This to me is a very, very incredible scene—all the people gathered together in order to bring about, if not for the first time for many other times, an understanding that we do live together. And the separation of oceans does not nullify the fact that our hands are stretched across them.

Interview with Paul Winter—following the first show, by Kai Arfin, coordinator of media.

Paul: A Zen Buddhist who was watching this whole psycho-drama and was detached from it would say, "What an incredibly interesting process this is as a manifestation of the New Age way of waging 'war'—of waging peace"—which is to bring together all these factionalized areas in human endeavor: science, art, religion, show business, environmentalists—and aimed for synergy—aimed for a synthesis. And what I get from scientists like Roger Payne and Dr. Michael Fox, who are two of the leading creature-oriented environmentalists in the United States and are two of the most literate, is that they are leery of trying to do it with words. They know—both of them have told me—that the culture is the way that people are going to be transformed, not with words. And that the whale songs, as one example, just by the whales alone, have done

Whales

more to increase the consciousness for saving whales than all of the scientific talk put together in one book. And that musicians can do more—not because they're better or anything—just because music is the closest thing we have to wildness. It's the one thing that transcends our reasoning, pigeonholing methods of thinking our way through life; and it's that magic that wildness has—which is the reason we're all fascinated with this—and music, for people who live in a civilization, is the closest thing we have to that wildness that does transmit the sense of mystery and awe of the creatures. So all of this is incredibly interesting; to see all the realities of the monies of the Japanese people who have mortgaged their own estates to make this happen—and they want to make sure that it happens from a Rock'n'Roll commercial end, as does Leo Makota—interweaving that with the ideals of the people who originally conceived it, which are the environmentalists; and that interwoven with the wishes of the musicians and their various egos and aesthetic inclinations as to who performs when and how much time they get. It's an incredible human process in which I see us as some of the more primitive creatures on earth learning how to live our lives together, and in this case, celebrating a much, much more highly developed creature who has known how to live its life in harmony with the earth for fifty million years. You know, it's incredible! And what I want to see come out of it is that we all see that the whales are teaching us, and just keep that theme going. As the American Indians knew for centuries—for *eons*, the wild creatures are our *teachers*. So that's one reason, a big reason, why I'm here. I think it's great. I'm not concerned by any of it; any of the human tension that's happening. Because we're coming through it; coming out the other side of it. I had never seen a whale, heard a whale, or felt for the whale. He was as distant to me as the distance from Pennsylvania to the middle of the ocean; and I had never been on the ocean. And it may take us coming back here for ten more celebrations, year after year. And it may take going to many other countries. It may take us cleaning up our act at home, because we're still the biggest whalers until we stop killing the dolphins for the tuna industry. I have no illusions that we're gonna stop it this weekend. But we're gonna start—we're sure gonna start the stopping of it.

Kai: Any comment on these meetings, some of which are just briefly and peripherally experienced here?

Paul: (laughs) I think these meetings are where it's at in terms of us discovering ourselves in this process, which is really the best reward we can take home. We already know how magical the whales are. We got a lot to work out. About ourselves and how to live together. Look at all the issues we've

talked on here this morning. You know, the human questions and questions of how we relate to each other, and people talking about—y'know—in a jocular way about beating each other up. We need to have these maybe every morning. And maybe this crisis is what's going to wake us up a little bit. 'Cause I know we all came here—we celebrated on the plane, we got here, we all fell asleep in a hotel. All we've been doing is eating free food for two days, and living on this ship of fools!

Excerpt from meeting in the Den Harumi following the first show.

Leo Makota: OK, I also noticed something last night that really surprised me and made me wonder about the separation between the music and visuals. They had a picture of a whale that was sailing on the wind last night before the show actually started; he had his flukes up in the air and was catching the wind and drifting along upside down. The Japanese audience didn't want to see it. They wanted it off the *screen*—they wanted the show to start.

“...the wild creatures are our teachers.”

-Paul Winter

Mark: Exactly.

Leo: At “California Celebrates the Whale” the audience would have been on their feet applauding.

Sandlofer: Yeah, but y'see, that's the difference between the consciousness.

Ric O'Feldman: The people in California are very turned on to it. . . .

Mark: Dr. Ui can create the whole aura of *reference* that we felt at California Whale Day. And the way he does that is he is respected. Because that audience out there is young and they know who he is, he can wipe very quickly from their minds the doubt that the Americans *don't understand* the Japanese situation as far as the whale goes. He can start by the simple explanation that he's a person who has grown up eating whale meat and still likes it very much, but that the whale is in danger—the resource *itself* is in danger of extinction, and therefore we have to stop till they increase. OK?

Ric: OK, point of order. If Dr. Ui starts this, and the environmental aspect being not what it was at “California”, please keep in mind that California, more than any other state or more than any place in the world is *very* whale conscious. So when you put that tail of the whale up there, they already know about it. Here in Japan we have the opposite, so it's a cultural problem. California is not Japan.

Richie: Didn't Dr. Ui do it without anything last night?

Mark: He started that.

Richie: Didn't he do it without *no* thing? Didn't he bring them together?

Ric: Can you translate what he said, Mark?

Mark: Wait a second, Ric. You said that because whale consciousness is higher in California, California people would be willing to sit in the manner they did watching the whale and the response would be different. I don't agree with that. A lot of those people in that audience came for Joni Mitchell and music and their awe at that footage of Roger Payne's was the awe of the whale itself. And the Japanese people will react the *same way*.

Noriko: They need preparation—introduction.

Mark: Dr. Ui's the preparation. His role is to turn the audience; open the door so that they're able to view that film of Roger Payne's, and you'll get the same reaction as in America.

Leo: Related to the film, there wasn't even *gonna be* any yesterday morning when I went over to the stage.

Mark: Now, that's from the Japanese side of production?

Leo: Yeah.

Mark: OK. There's our source of the problem again.

Ric: A Rock'n'Roll show.

Excerpt from meeting at Den Harumi (On Gov. Brown).

Leo: Right, I know where he *is*, I know who he's *with*, I know who his representative is to be spoken to. His representative is in contact with me, and Gov. Brown does not want to talk to *anybody* else except for *me*.

Mark: Just a second. Let me ask this question. Is Stewart Brand with him?

Leo: No.

Mark: Stewart didn't come?

Leo: I don't think so. All I know about Gov. Brown is that there *is* someone who is supposed to speak to me that is with him, and he wants to speak to *me!* He doesn't want any more phone calls from Dolphin Project people; he doesn't want any more phone calls from anybody *does not want it*—that's what was told to me by Gov. Brown's office yesterday morning.

Anonymous: He's got no position. That's why.

Ric: Then he can quit calling my room, because *he* called *me* every day.

Leo: Outtasite. I'm just telling you what his office said to me on the phone.

Mark: There's a reason *why* whoever can call him, whether it's Leo or Ric or me should *try* to confirm that man's presence. Because if he's coming and we can call the Japanese media and say, "Gov. Brown's here", we know that (snaps fingers) every media will be there.

Leo: If you call the press now, and tell them that Gov. Brown's likely to be here at any certain time, or that he had any communication with us, or *anything else*, you've just fucked him OVER!

Mark: He wouldn't come, you're saying.

Leo: Yeah! Because he's here for an AUTOMOTIVE MEETING! He's not here for this environmental event! And when he takes the time out of his schedule to come for this, it's him putting himself on the limb, and he has the opportunity to choose when and how he wants to do that.

(As it turned out, Gov. Brown did appear on Saturday night making an appropriate, succinct speech and then introducing "Another Browne from California, Jackson Browne".)

Scoop with Country Joe McDonald

Scoop: What's your over-all feeling about the event?

C-Joe: Well, I think it somehow in many ways resembles Watergate and the Nixon Administration; where there's a mixture of good and bad. And I think that until an investigation is done we won't really understand what went down here. But they are forming a bilingual international investigation team, which will investigate all that's gone down, not only here during these four days, but in the three months which preceded this event. And it's made up mainly of people from Sweden and Thailand, in order to be impartial.

Scoop: Now, when you were onstage in front of that Japanese audience, did you "Give me a W— Give me an H— Give me an A— Give me an L— Give me an E", right?

C-Joe: That's right.

Scoop: Did you get a good response?

C-Joe: Yeah! They stomped their feet for ten minutes, demanding an encore but I wasn't allowed one.

Scoop: Uhh. OK. That was Joe McDonald. Thanks, Joe.

C-Joe: I wanna say hello to my—my mother.

Scoop with Fred Neil

Scoop: In spite of the financial boondoggle, what about the whole event?

Fred: I think it was great. We've done it. We have done it, man, and we did it together, you know? The musicians did it. There was not that much politics, no politicians, very few managers and agents and all that crap, man. A little, but still, we did it. And I'm very proud, man.

Scoop: What's the Dolphin Project's next project?

Fred: The first project is our next project! We have been trying to get out there—we have two dolphins that we turned loose out around Bimini, and we've been trying to make contact with them again; we spent some time with them for a couple of years, you know. What we're trying to do is to get a contact station together and do some experiments with many things like music and color.

Scoop Nisker interviewing Michael Sandlofer (of "A Right To Live"): (At the Harumi Dome exhibits site)

Scoop: So whaddya think the significance of this event's gonna be?

Sandlofer: Now I can honestly say for the youth of the people here, the young Japanese people, they *do believe* this exhibit is as much theirs as it is ours. We supplied them with the factual information; we didn't make it courteous or proper, whatever. We said: Facts. Japan and Russia are responsible for the mass slaughter . . . AND Japan, or three companies in Japan, are responsible for supporting South Korea's, Chile's, and Peru's pirateering operations. I've learned one thing here: it definitely is *not* Japan. It is three companies.

Scoop: Do you think that these exhibits are changing the consciousness?

Sandlofer: Well why don't you look around, man. I mean, the people, or

whoever's gonna hear this can't see, but I'm like 6'-3", 200-and-something-pounds, man, and I'm telling you I'm about to cry. It is *reeaaaalll*, boy, and I mean they *feel* it because it's all in their language and their interpretation.

Scoop with Dr. Clifford Uyeda (of Japanese-Amer. Citizens League)

Scoop: Do you think this event had much of an impact?

Uyeda: Yes, I think it really did, because I have spoken to several persons from Japan and they were at the beginning very apprehensive, thinking that especially with an environmental type of an

event brought to Japan, that they thought there might be some problems or trouble, even. But nothing happened; the whole event went through for three days with no problems at all. They felt that here's an environmental event as large as this, as well-publicized as this, and no bad things happened—which meant that they feel that now they could go ahead and do other events without fear.

Scoop: What about the direct effect on the whaling industry or the peoples' consciousness of the whaling problem?

Uyeda: I was over at the Tokai University "Whale and Ocean Conference" on the 8th and 9th (of April), and most of the Japanese representatives were actually associated with the Japan Whaling Association (JWA). And somehow they seemed to be waiting for me to come over there with . . . I think they

continued on page 30



"The seas must live." Dolphin Project Japan and USA in San Francisco; Shigeru Izumiya, Noriko Abe, Matoshi Iwanaga, Dr. Clifford Uyeda, Mark Lavelle, Leo Makota.

Scoop: How would you recognize those dolphins?

Fred: Well, they do have markings on them and they'll recognize Ric O'Feldman and they'll come right to him. And, you know, that's where we were starting when this whole thing came up. So we stopped everything and said "Hold it, this really does take preference." So, this is how we ended up here, man, from right out of left field. I'm still not gonna believe this all went down till I get home.

Scoop: And the feeling between the musicians . . .

Fred: What a bunch of love, man!

Scoop: And the jams in the night . . .

Fred: Oh, yeah, yeah. And you know, there's gonna be a lot of music coming out of this . . . I'm not gonna know where it came from, but it was from here.

by Janet Henshaw
Danielson

Danielson: *What I'd like to know is something about your past career. What originally attracted you to electronic music?*

Stockhausen: The question is wrong, because I started the electronic music. All I had heard during the time when I studied music in Cologne of the kind of experimental music that was leading to electronic music was the music from the Columbia Center of New York (now Columbia-Princeton Electronic Music Center), which was mainly recordings of instruments treated with filters or other electronic devices, and *Musique Concrète*, which was music of sounds recorded from nature and then manipulated in the studio. And what we call nowadays *electronic music* was started here in 1953, when we synthesized sounds for the first time with generators, which means with sine-waves or other kinds of waves, or by filtering white noise with different kinds of filters in order to compose colored noises.

Danielson: *But what was it that originally made you want to work with electronically-generated sounds as opposed to concrete sounds?*

Stockhausen: Well, when I was working in Paris in the Studio for *Musique Concrète*, I found out that the composition of the timbre was fairly experimental. The whole composition of the timbres in the Studio for *Musique Concrète* was mainly conducted out of a general desire to have strange sounds, but there was no systematic research in the synthesization of spectra and of the inner structure of sound. And I started in Paris making the first experiments with sine-wave generators in the basement of the Post Téléphone Télégraphique—the PTT, it's called. They had a sinewave generator and Professor Moles, André Moles, who later on became famous for his books on Communications Science, gave me the possibility of working with this generator. I recorded individual sine-waves on records—I played several records simultaneously because

in this studio there were no tape recorders at that time—and I synthesized the first spectra. So the will to do this was conditioned by two facts: one fact was the situation in Paris where I thought the synthesization of sound was amateurish on the level of timbre composition, and second, I was in a very intimate exchange of letters with the Belgian composer Karel Goeyvaerts; he had expressed in several letters that he wanted to obtain sounds which could be better controlled than the sounds produced by musicians with respect to the amplitudes, with respect to the combination of overtones or partial tones in a spectrum, and also with respect to the attacks. And he tried to work in a studio of the film company *Gevaert* in Brussels, and asked me if I could continue my research in Paris in finding the generators of pure waves. So we were both wanting to enlarge the field of musical composition towards the *inner structuring* of the sounds themselves.

Danielson: *Was this partly for the purpose of more exactness in making a series, so that—*

Stockhausen: No, it was mainly conditioned by our whole concept of art, that the emotional attitude in making sounds should be *cleaned* before we were to start with the new concept of timbre composition. Everything that concerned timbre was so approximate—and still is, in working with musicians who play traditional instruments—that we wanted to apply the same degree of control also to the timbres, and not only to the dynamics and durations and pitches, because we found that it didn't make sense to start with the composition of the three parameters and leave the timbres at random, or leave the timbres to general taste, or to such an approximate way of producing them as the musicians making these timbres are used to. I think it wanted simply a generalization of the same method to compose also the inner structure of the sound, and I think in my personal case it was mainly influenced by my whole way of working in general through the influence of the physicists and, in particular, of the mathematicians whose

Karlheinz Stockhausen

The Search

Interviewed in Cologne

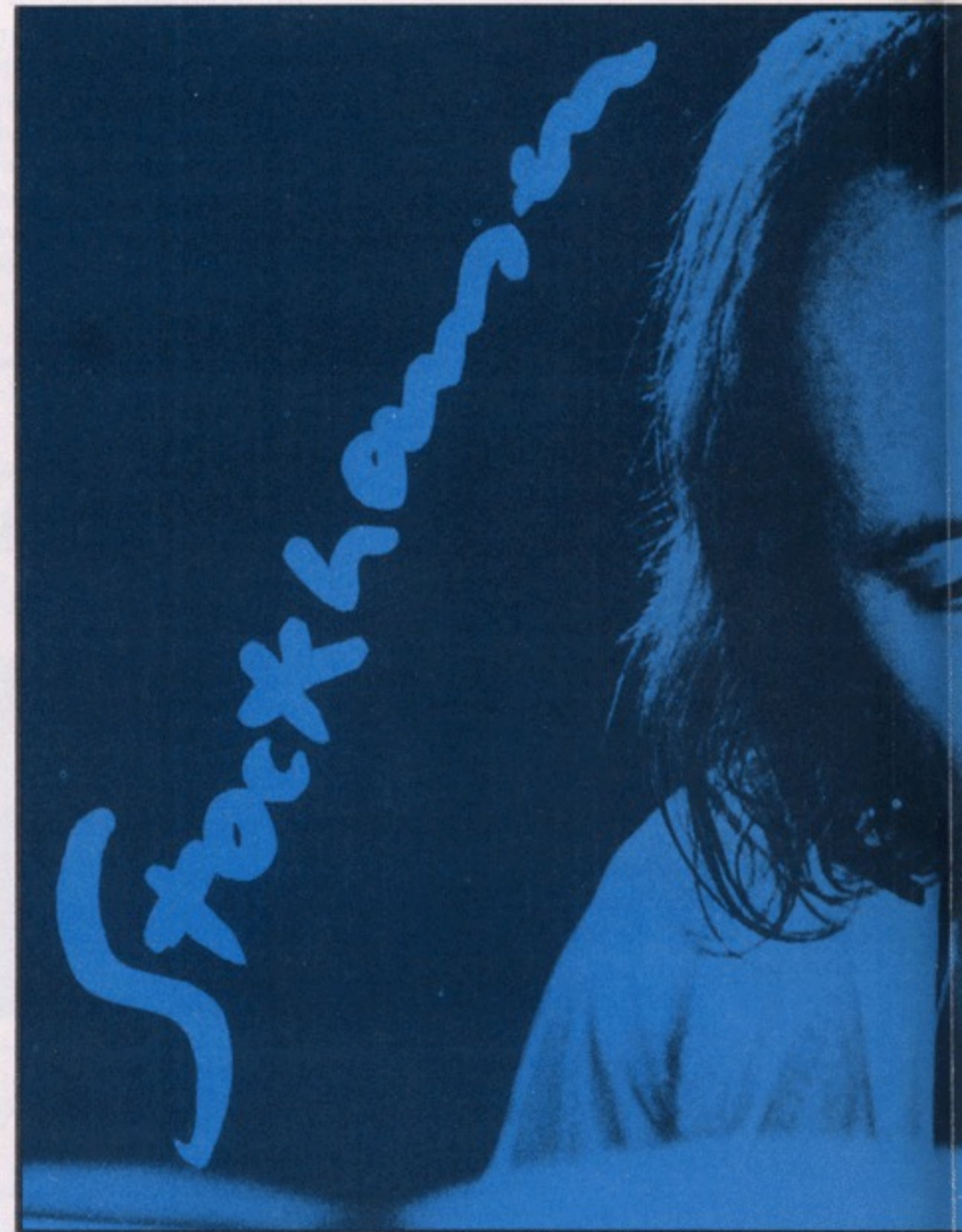

Part 1: *Here is a rare opportunity to describe the personality of Karlheinz Stockhausen, his needs and describes instruments he has conceived. His conceptions reflect his wish to explore the inner scale of fifteen vowels and a consonant generation, at least as much variety in playing these timbres as possible. Also followed are the reoccurring elements of Stockhausen's music, as evidenced by many of his compositions.*

This is the first of a two-part interview with Janet Henshaw Danielson in Cologne, West Germany.

Stockhausen: For Control Cologne, April 1977.



PHOTOGRAPHS BY BERNARD PERRINE

...nity to explore the complex musical
...z Stockhausen. He discusses his instrumental
...ived to meet these needs. These design
...er structuring of sounds. He proposes a
...ator for all instruments "So that we have at
...as someone has who can sing or speak."
...Stockhausen's beliefs and interests as

...part interview conducted for Synapse by
...Germany during April 1977.

books I had been reading at that time, so nuclear physics was a very important influence, naturally, on my whole approach to the sounds. I wanted to compose the microstructure of the sounds also, just as the physicists wanted to know more about the microstructure of any kind of matter. For me, sounds were something that I should take apart, so to speak, analyse, and then synthesize.

Danielson: *You were a devout Catholic during the fifties. Did this affect your work, or was the influence more from science?*

Stockhausen: Do you mean influence? When someone is religious, that is not an influence, that is himself; so the *Gesang der Jünglinge*, the *Song of the Youths*, used a text which is sung every Sunday after Mass. It is the song of the three young men in the fiery furnace, and so far you naturally can always trace in my music my religious conviction. Also the very first pieces like the *Chorale*, with a text I made myself, or the *Songs for Doris (Chöre für Doris)* or the text of *Drei Lieder* for alto voice and chamber orchestra always contain religious elements, so that shows my religiousness. Well, perhaps it is true that the desire to penetrate with my consciousness into the subsonar levels of the sound has something to do with my religious conviction that I would like to spiritualize the matter down to the bottom.

Danielson: *After Kontakte, there were quite a few years before you worked again with purely electronic sounds.*

Stockhausen: Yes, because naturally, *Kontakte* was already a combination of live performance, live electronic music, and recorded electronic music, and between *Kontakte* and *Hymnen*, which I started working on in 1965, I had realized *Mixtur* for orchestras with four ring modulators and sine-wave generators, and *Mikrophonie I* with filters, potentiometers and all sorts of devices that allow a special process of microphony—what I call microphony—where the microphone becomes a musical instrument which is moved with specific rhythms and specific distances from the surface of the

instrument that is scratched or rubbed or hit, et cetera. And *Mikrophonie II* is for twelve singers and ring modulators, four ring modulators, and electric organ which is fed into the ring modulators. I became very much interested in the process of integrating pre-existing sounds into the world of synthetic sounds, and already in *Gesang der Jünglinge*, *Song of the Youths* this is the case. I used voices, and I worked with seven degrees of intelligibility of the text and of the sounds themselves—I mean, between sounds which sound completely abstract, and sounds which we know. I have always tried to mediate; so my whole life has been an attempt to combine what we find in the world of sound, and what we can add to the world of sound.

Danielson: *In Telemusik and Hymnen, you used sounds which had very rich extra-musical associations—for example, the national anthems would represent the countries—and that seemed to be a new development for you.*

Stockhausen: I don't know—I mean, in *Song of the Youths*, the sounds of the young boy also have implications which are metamusical which means religious, of a special kind; and in *Kontakte*, when you hear the skin sounds, the wooden sounds, the metal sounds, you also hear a certain number of sounds which remind you of sounds which already exist in the field of instruments, so there are always windows in my work which show something more general, and in *Hymnen* national anthems naturally represent also the countries, like the boy in the furnace represents a religious person who is tortured. The spiritual aspect is always there in my work, but when I use national anthems, there are two reasons: not only to represent the countries, but also to use tunes which everybody knows, because everybody is familiar through the Olympic games and through all the events that take place in a nation, with the tunes of the national anthems. So this gave me the possibility of treating these very popular melodies in a special way because people can follow what I am doing. And the same is true in *Telemusik* where I have short fragments of pre-existing music

Stockhausen: "From collectivity you

which are archetypal, extremely old, and well-known by many people. This is the main aspect.

Danielson: *Have you ever questioned your own role as a composer in light of the fact that in non-Western cultures composers as such don't exist? Music is either a tradition or perhaps collective work or solo improvisation.*

Stockhausen: Well, I have been brought up in an environment where the objectivity of man was a goal, a high goal. And I lived in a village where you can find a Medieval cathedral of the Gothic style, and there are paintings which are hidden far away from the eye of a person who is in the church because they are too high, hidden in corners of the ceiling which is sometimes sixty, seventy feet high. But this was part of my consciousness, that the most beautiful things are sometimes very hard to see or hear, so impersonality was something I got used to at a very young age. I also was brought up in a German environment in which something like Bach's saying that he dedicated most of his works to God, not to the people, was very important; so he would work no matter how many people like it, because music was religious worship—it should please the Creator, and the most unlimited, the greatest possible Creator. In this context, the East, or the Eastern tradition seems to be a Medieval situation compared to modern Europe and the European individualism which came through the Renaissance and everything afterwards. So present-day man in Europe is more and more atomized, isolated and egotistic or subjective, and the art has shown this. We have no longer the kind of concept where you don't know the name of the architect who built the Cologne Cathedral—there is a master so-and-so. Perhaps they might discover somewhere on a stone some name of that architect written in Latin, and the stone is totally hidden in the tower, where nobody ever comes. But this time is gone, and I have said recently in Japan—last year I visited Japan—to a whole crowd



of Japanese composers who asked me a similar question, that they *will* go through the same kind of personal concept of the creator, of the maker of music, of the arts, and you cannot avoid it. From collectivity you have to go through subjectivity. Then back to collectivity is the trend in our country now, in particular through the socialist movements; they try to represent the idea of the artist as an exponent of society, of the collectivity, so the artist would just express what everybody else feels, et cetera. That is their concept of the artist, but it won't work, naturally, because after a short while we will have a strong swing back to subjectivity. We always have this pendulum in what I call the emancipated societies, which are no longer ruled by the church, or by a collective clique like a party, or a so-called "democratic" team

that decides what's good in the arts, and what's not good for society and so on. These are also transitional, I think. The final situation in a completely adult humanity, will be that the artist is *highly* subjective, but willing to make only contributions to humanity which raise the consciousness of the others and which are not glorification of an ego. So there is the combination of subjectivity and at the same time the willingness, because of a deeply religious attitude, to serve mankind, to rise constantly in consciousness.

Danielson: *Back to more technical matters, you talked earlier about the pieces like Mikrophonie where you have instruments and electronic manipulation of them. You use this quite a bit—do you find it works well?*

Stockhausen: Well, we have

not yet the means. I am constantly designing, and have been for several years, new apparatus which can be used during the moment when music is realized, performed.

Danielson: *Like Modul 69B, which you used in Mantra?*

Stockhausen: That's one, but no, but more, more. Now I have designed another apparatus for the Paris studio Ircam and they are working on it now, which should be used to allow every musician playing a traditional instrument—because that's what they have learned, and you cannot just throw them away so easily—like a trumpet, or an electric bass clarinet, or any kind of instrument that has a fairly rich spectrum, to produce a scale with fifteen different vowels. It can be played with a touch-sensitive keyboard that is attached to the instrument

have to go through subjectivity.”

mechanically, and it runs through a small device that doesn't need to be where the musician is, which allows them to play a scale precisely—a chromatic scale, if you like—between (u) and (i), so there should be a scale of fifteen vowels. And then I would like to have an additional device which allows all kinds of consonants at the beginning of the sounds—instrumental sounds—and at the end of instrumental sounds, so that we have at least as much variety in playing these timbres as someone has who can sing, or speak.

I then want another instrument built that allows an assistant of a given musician to make the sound move in a hall with any speed that is desired, and in any direction in the hall, and that is simply complicated. So I am not satisfied with what we have nowadays, but it will last another two, three generations, and I am now telling the people what should be done, and then they will continue to develop these instruments.

And I want another device which allows more precise control of the dynamics. I think it is possible and meaningful to have sixty degrees of maximum

amplitudes that can be controlled by the musicians either with a keyboard for sixty dynamic degrees or with an assistant who does it together with the generating musician. So perhaps with duos or trios—one player with two additional players—one can achieve the complete control of the timbres and the dynamics and the sounds moving in space.

Danielson: *Can the human ear perceive sixty degrees of loudness?*

Stockhausen: Easily.

Danielson: *Easily?*

Stockhausen: Absolutely. They are of the *phon scale*, and the phon scale is based on perception, which means a phon is defined as the smallest degree of loudness. For example, I wrote an orchestra piece two years ago which is called *Inori*, and in *Inori*, I managed to work constantly with sixty different degrees of dynamics through the energy of a defined number of instruments playing the same note at the same time, and I play this scale with the orchestra from the smallest degree, which is a flute pianissimo—one flute—and the strongest degree of the scales used in *Inori*, sixty,

which means everybody playing fortissimo—ninety musicians. And this scale is worked with a logarithmic curve of the number of instruments, as I said before, and the intensity with which they play. I used the five traditional intensities from pianissimo to fortissimo—pianissimo, piano, mezzoforte, forte, and fortissimo—only five degrees written. But the rest has all been taken care of by me, as I have composed a scale of defined numbers of instruments playing the same note. This scale works very well, and it actually occurs during the piece: At a certain moment, there is a crescendo spread over one minute in sixty degrees, each one second long, and a decrescendo, and you hear perfectly the increase of dynamics from step to step, and the decrease as well.

Another device which I badly need, and which I have designed but which nobody has built yet, is an apparatus which makes it possible to record sequences during the performance—let's say sequences which go up to three minutes long, if possible—and then during the performance to compress the melodies of these sequences, or to expand them,

and to play them or sections of them back at any given moment, with a device which can record, let's say four—that would be enough for the time being—four different kinds of sequences of different musicians playing, that I could call back instantly after they are recorded, with any kind of compression in time and expansion in time—for a single sequence let's say up to about sixteen times slower, or up to I would say about (it would be already enough) three hundred times faster—and also to make it possible, to expand the melody up to five octaves and to contract it down to zero. To zero means that I have just a single pitch with a rhythm remaining. So all the possibilities you have with a synthesizer which has voltage control, I want to have in practical performance. For example, years ago in Japan I composed a piece, *Solo*. It's printed and it was performed only three times, but then it couldn't be performed any more. It needs an electronic device to record sequences up to forty-five seconds long and then play them back, and also to play back later superimpositions up to 18 layers of fragments of this recorded sequence, so that the musician can play with his own recorded music and make polyphonic music with himself. So all this doesn't exist yet.

Danielson: *Did you ever perfect a device for swallowing sound, that could eliminate musical garbage?*

Stockhausen: Yes, yes. Well, it doesn't exist yet—perhaps it's a utopian idea, but I still think that one day one will invent something to create what I call silent areas in cities. So how this is technically done they have to find out, but it must be possible to create silent zones, where no matter who makes the sound, you can't hear it. I said the sounds should be produced in counterphase, to create a completely silent area, because I think that it is absolutely necessary. Just as you have a visually clean world, or a world which is clean of garbage, you should have also areas which are clean of acoustical garbage.

— Continued next issue. —



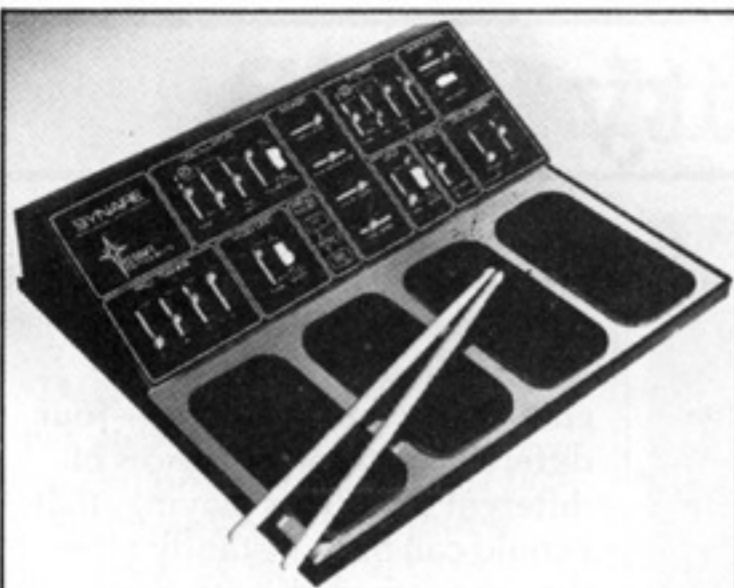

SYNARE P.S.

electrifies the drummer

The innovative SYNARE™ Percussion Synthesizer puts crashing ocean waves, sirens, cocoanuts, chimes, brake drums . . . under your sticks. Designed for use with or without a drum set, the Synare P. S. is played with sticks like a drum, has bounce, and requires only a conventional sound system. Suggested retail \$795.00

Write for information and nearest dealer.



STAR INSTRUMENTS INC.

Dept. S, P.O. Box 71
Stafford Springs, CT 06076
Tel. (203) 684-4421

Whales

from page 25

thought maybe we were going to be coming with a very angry, militant type of stance. But when I explained to them that actually this is not so at all, many of them said they were rather surprised. And also there were other people there who felt that the way we did this event this time, without the finger-pointing, without anger . . . then I told them that actually we *use music* to try to communicate with the Japanese people; because there's *no way* that you could express hatred or anger through music.

Scoop with Danny O'Keefe

Scoop: What was the highpoint of this event for you?

Danny: Singing my song. The song that's in Japanese. People here helped me translate.

Scoop: What did it say? What was the translation?

Danny: "Itobi toyo Kugira-o suku wa nakereba kugira-o suku wa" — which was "Everybody, we must help save the whales or they will perish" or "we must conserve them". And the last line was "Taiyo no kodomo tachi minade kugira-o suku-o" which is "Children of the sun, help us save the whale."

Scoop: And you wrote that song on the plane coming over?

Danny: No, I wrote it when I got here. I wrote the verses when I got here; I had the music roughly together, and I made it so that I could change it.

Scoop: So you feel like you really communicated with that song?

Danny: Yeah. I think so.

Scoop: They cheered when you sang in Japanese.

Danny: Yeah. I could really feel it well. I was scared, you know, . . . I was scared shitless.



TO in Tokyo: Stefan Weisser and Will Jackson gave "demonstrations" of sound in species interaction and language.

Scoop: You were scared bleepless.

Danny: Oh, that's how they say it here. (laughs)

Scoop: So you think the impact of the whole event was positive, and good and strong?

Danny: I think so. A lot of people are aware of it. That's as much as you can do, is create that awareness. It'll be up to them to decide what they want to do about it. But it seemed like they're very oriented, no pun intended, to American ideas and ideals, and if they feel that we're really that much into it, I think it's just a matter of time.

Scoop with Mimi Fariña

Scoop: What's your feeling about the event? Do you think it had an impact on the people?

Mimi: I have no idea. It's hard to tell—there's no way to judge. I think that as a whole, the audiences got more raps than any other benefit concert that I've ever seen in my life. But I don't know what they're used to, and if they paid any attention or if it makes any difference. Of if they just came to hear the music and hang out. It didn't seem like that much of a "party"; for one thing the lack of dope and booze in the audience made me feel as though they were a little more attentive than our audiences. I know the ecology people were all upset because there wasn't enough rapping and enough explaining. But it's hard when people pay tickets to hear music, to push it down their throats. I don't know.

Scoop: Yeah, it's really hard to say what kind of an effect it had.

Mimi: We can only speculate. We'll probably know twenty years from now. ~~~

Good news from EML
SPECIAL PRICES
Get more for your money. For a limited time we've reduced our prices on the board.

POLY-BOX
Now add 26 additional pitch sources and a unique polyphonic capability to your synthesizer. Adapts to most synthesizers.

KITS FOR SYSTEM DESIGNERS
Do it your way. Design a system that fulfills your own creative requirements. Complete instructions for special applications available.

Write or call today. **NOW CALL TOLL FREE 1-800-243-7270**

EML electronic music laboratories, inc. makers of ElectroComp Synthesizers
P.O. Box H, Vernon, CT 06066 • (203) 875-0751



PRODUCT SUMMARY
for
Computer/Synthesizer
Equipment

FROM: PAIA

1977

COMPUTER AIDED SYNTHESIS

new real-time performance capabilities

For the Musician/Composer

EXPANDABLE

4700/J

By anyone's standards this is a BIG synthesizer, as you can see by reviewing the module complement.

Like our other packages, it may be used without a computer as a normal monotonic synthesizer.

With a computer in the loop, you are ready to do polyphonic instruments, multi-track recording work, and innumerable composer and performer assisting functions that are only possible with a computer/synthesizer combination.

The 4700/J module complement consists of: the 8782 Encoded Keyboard, digital to analog converter, QuASH, two 4710 Balanced Modulator/VCA's three 4720 Voltage Controlled Oscillators, 2720-5 Control Oscillator/Noise Source, three Watt Block Power Supplies, two Envelope Generators, Reverb and two Wing Cabinets. Included are step-by-step instructions and using manual. Also includes a 4730 Multi-modal filter and one 4711 Stereo Mixer.

#4700/J SYNTHESIZER KIT \$549.00
(shipped freight collect)

8782

An n key roll-over scanning matrix encoder tied to a 37 note AGO keyboard provides 6 bits of data and both STROBE and STROBE control outputs. Input control lines to the encoder include SCAN (starts and stops the encoder clock), RESET, START and RANDOM making the keyboard universally applicable to all computer/processors from the very largest to the very smallest.

Housed in a trim and sturdy vinyl covered road case, the kit consists of all parts including keyboard, power supply and detailed assembly instructions; software overview for computer applications and detailed instructions for digital sample and hold.

#8782 .. ENCODED KEYBOARD KIT \$109.95 32 lbs:
(shipped freight collect)

Up date PAIA (or other) keyboards to the new digital format. Consists of encoder circuit board and all parts required to modify your present keyboard for use with computers and/or the 8780 D/A. Off-print instructions from "Computer Music Without The Computer", Polyphony 4/76.

#EK-3 .. KEYBOARD ENCODER EXPERIMENTER'S KIT \$14.95
(plus \$1.00 postage)

8700

An exceptional price on an applications oriented 6503 based micro-processor system featuring: 1K bytes RAM locations (512 bytes supplied), 1K bytes ROM locations (256 byte monitor included), two 8 bit input ports, two 8 bit output ports, one latched and one buffered.

A 24 key touch operated keypad is used by the monitor to allow entry and execution of user programs and is also user definable. Two latched seven segment displays are used by the monitor to display memory location and contents, also easily user programmed.

An optional Cassette Interface is available (\$22.50) that fits entirely on the processor board allowing the use of any audio cassette recorder for program storage.

The 8700 fits in a space reserved in the 8782 Encoded Keyboard's case. PAIA software support available for Electronic Music Synthesizer interface.

#8700 .. COMPUTER/CONTROLLER KIT \$149.95
(plus \$3.00 postage)



MODULAR...TO SUIT YOU

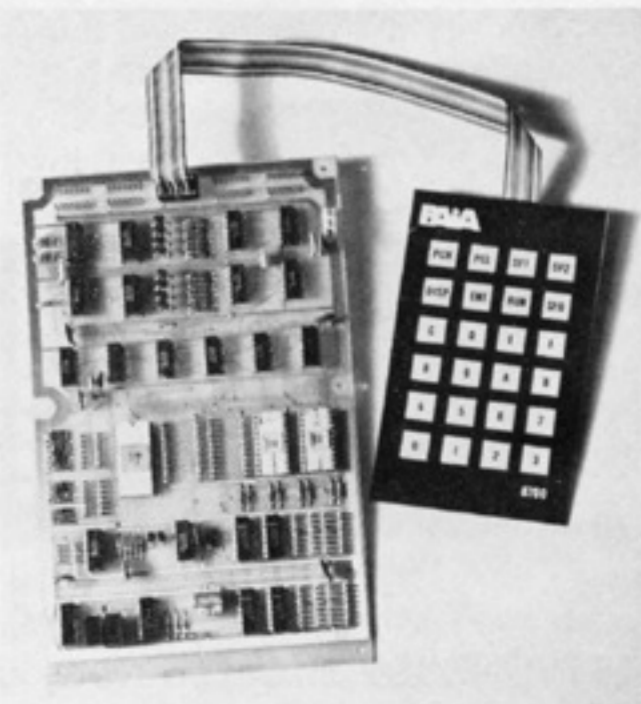
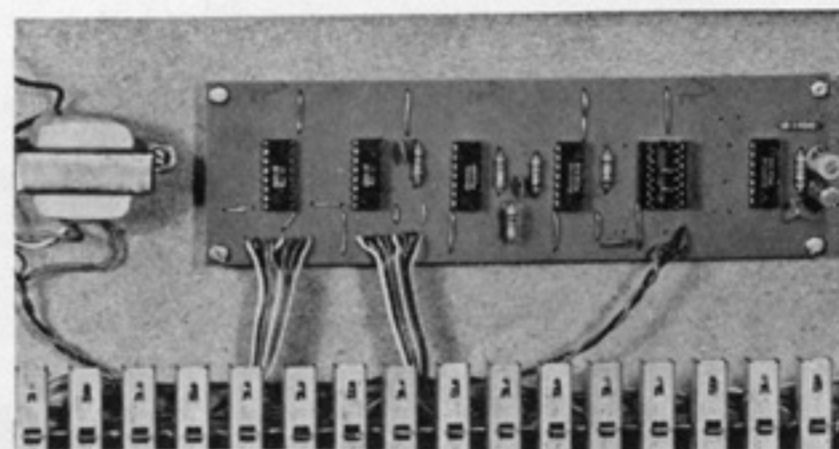
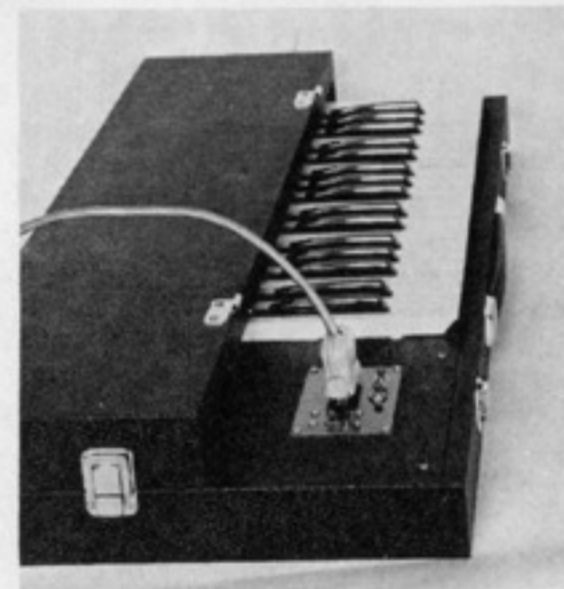

COMPUTER MUSIC that sounds not just good but great! For the Computer-oriented Hobbyist/Professional

PACKAGES



4700/C

The ideal monotonic starter system. Can be used without a computer/processor as a conventional electronic music synthesizer.

By simply unplugging the synthesizer head from the keyboard, a computer can be put into the loop to provide power and versatility never before possible for synthesizers of any cost.

The 4700/C module complement consists of: the 8782 Encoded Keyboard, Digital to Analog Converter, 2720-5 Control Oscillator/Noise Source, 4710 Balanced Modulator/Voltage Controlled Amplifier, Reverb, Voltage Controlled Oscillator, Voltage Controlled Filter, Envelope Generator, two Watt Block Power Supplies and a 4761 Wing Cabinet. Complete step-by-step instructions and using manual.

#4700/CSYNTHESIZER KIT\$325.00
(shipped freight collect)

CUSTOMIZING NEEDS



8780

Unlike more conventional R-2R ladder type digital to analog converters, the PAIA 8780 kit is based on a multiplying principle that allows the module to generate the exact exponential stair-step function required to make even the simplest linear response oscillators and filters produce equally tempered musical intervals. The 8780 uses only 6 bits of data to generate over five octaves of control voltage. In an 8 bit system, the remaining two bits are ordinarily reserved for trigger flags, but may be used to provide micro-tonal tunings.

The module is physically and electrically compatible with the complete line of PAIA music synthesizer modules and is easily interfaced to any micro-processor with or without hand-shaking logic.

#8780 .. D/A CONVERTER KIT \$34.95..... (plus \$1.00 postage)

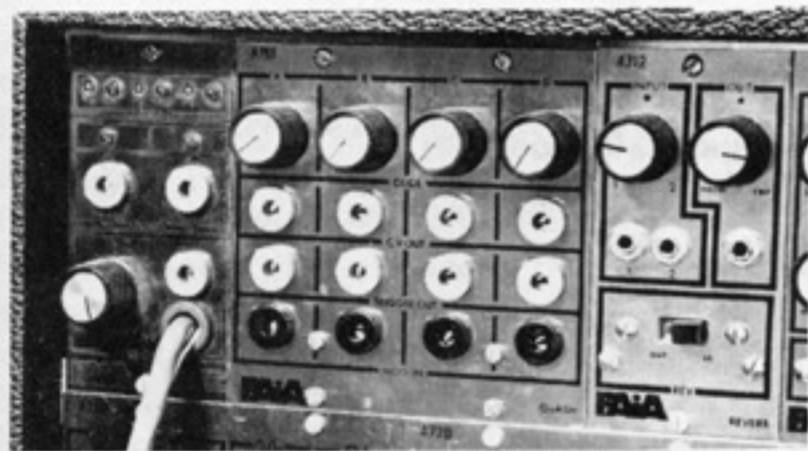

8781

The least expensive way to provide multiple Control Voltage channels in a computer based synthesizer system is to multiplex the output of the D/A using multiple, computer addressable, Sample and Hold circuits. The QuASH provides 4 of these outputs in a single module.

Other features of the module include: adjustable glide rate for each channel with the glide selected or de-selected under computer control, individual trigger "gate" signal associated with each output channel and individual modulation input for each channel that is non-interactive with other channels.

On-board address decoding allows up to 4 QuASH to be bussed together in a single system without external logic and Bank Select input allows external logic expansion beyond this point.

NOTE: THE QuASH MUST BE OPERATED UNDER COMPUTER/PROCESSOR CONTROL.

#8781 .. Quad Addressable Sample & Hold\$34.95
(plus \$1.00 shipping)

next ?

NOT A DEAD END
But continuing development
keep in touch

COMPUTER/SYNTHESIZER SPECIALS

To really get you started in the right direction, we're offering the following special packages:

P-4700/C MONOTONIC Package

KIT	REGULAR PRICE	SPECIAL PACKAGE PRICE
4700/C Synthesizer	\$325.00	\$325.00
8700 Computer Controller	\$149.95	\$149.95
PS-87 Power Supply	24.95	free
CS-87 Cassette Interface	22.50	free
PMUS Software Cassette	5.00	free
	\$527.40	\$474.95 (shipped freight collect)

P-4700/J POLYPHONIC Package

KIT	REGULAR PRICE	SPECIAL PACKAGE PRICE
4700/J Synthesizer	\$549.00	\$549.00
8700 Computer/Controller	\$149.95	\$149.95
PS-87 Power Supply	24.95	free
CS-87 Cassette Interface	22.50	free
MUS 1 Music firmware prom	20.00	free
PMUS Software Cassette	5.00	free
Additional 512 Bytes RAM	7.00	free
	\$778.40	\$698.95 (shipped freight collect)

* OTHER STUFF *

PS-87.....Computer/Controller Power Supply	\$24.95 (plus postage 3 lbs.)
CS-87Cassette Interface Option	\$22.50 (plus \$1.00 postage)
MUS 1.....Music firmware prom	\$20.00 (plus \$1.00 postage)
PMUS.....Software Cassette	\$ 5.00 (plus \$1.00 postage)

* Attention KIM owners *

We have several products available to owners of MOS Technology's KIM series of micro-computer products.

KIM Synthesizer Package

Detailed instructions on interfacing KIM-1's to the PAIA Synthesizer equipment. Package includes software cassette with multi-track recording/playback, compositional (computer "composes" music) and several polyphonic routines.

KIM MUSIC PACKAGE#KMUS \$4.95 (plus \$1.00 postage)

[The KMUS package is FREE for the asking when you purchase a 4700/C or 4700/J Synthesizer package.]

TELL ME MORE!

An information package comprised of Polyphony offprints, Using Manuals and more is available to explain in detail how it all works and the unlimited applications possible with computer technology applied to music synthesis.

Send I-COMP (Friendly Stories About Computer Music) \$1.00 enclosed.

Name: _____

Address: _____

City: _____ State: _____ Zip: _____



SEND FREE CATALOG listing the full line of PAIA kits.

ELECTRONICS, INC. DEPT. 10-S, 1020 W. WILSHIRE BLVD., OKLAHOMA CITY, OK 73116

by Craig Anderton

John Simonton is President of PAIA Electronics, Inc. an electronics company dedicated almost exclusively to musical experimenters. After having the opportunity to both work and relax with John, I thought his views would be of interest to Synapse readers. We talked a little about designing and then got into how PAIA is going about mating computers to music.

Synapse: How would you say your products compare to Moogs, ARPs, and equipment like that?

John: Well, the PAIA equipment as it exists today is in my mind a lot more experimenter oriented than the Moog equipment, which is dedicated to the performer. While our stuff is at home in that kind of a situation, it's still for the person who is more interested in the mechanics of electronic music rather than the performance of it.

Synapse: You say PAIA equipment as it exists today. What kind of things are you planning on putting out in the future?

John: The current issue of Poliphony [PAIA's privately published, customer magazine - ed.] introduces PAIA's equally tempered digital to analog converter, which ties in with our computer music synthesizer. The D/A converter allows you to connect linear oscillators and filters to anybody's computer; but it doesn't have to be used with a computer the way we're doing it. We're also introducing a keyboard encoder for AGO keyboard, and that will allow you to tie in directly to the D/A converter. Then, hopefully, we're going to finally introduce the computer that goes along with it.

Synapse: What's its function?

John: In the original system, the computer gives you a lot of help on keyboard. One of the features is a memory sequencer. Play into it, punch a button, and it plays back to you. Unlike some of the digital sequencers that are available, you will be able to go in and write new software to massage all that data you have in memory. For example, if you're doing something like a 12 bar blues line, you don't have to play in the whole thing. All you have to do is play like a measure of the figure, and then put instructions into memory on how to manipulate it.

Synapse: This is all real time you're talking about, yes?

John: Oh, definitely. The next step beyond that is to set up patch bays that are controlled by the computer so you will not only get a keyboard assist but the ability to change patches, instantly, either by pressing a button or going ahead and letting the computer do it itself.

John Simonton



PHOTOGRAPH BY RHONDA FLEMING

Synapse: Is this system polyphonic?

John: That's one of the features the processor gives, yes. A lot of people ask if you need an oscillator for every key. You don't, but you do need an oscillator for every note you think you're going to be playing simultaneously; you can use up to eight or ten oscillators without problems.

Synapse: Speaking of the oscillators, you say to use the D/A converter with linear stuff, and of course, the whole PAIA approach is linear based. Is there any reason you went with linear response, rather than the standard exponential response?

John: Yes, it's cheaper.

Synapse: Is a linear approach easier for mating to computers?

John: No, as a matter of fact we're going to turn a lot of heads around; many people say you can't use linear oscillators because they're difficult to interface to a computer. The reason they say that is because they're thinking in terms of an R-2R ladder type digital converter that produces equal incremental voltages. If you count into an R-2R ladder, you get voltages like 1/12V, 2/12V, just like the voltages you get out of

a keyboard designed to operate with exponential filters and stuff. But our D/A converter is different in that it is an equally tempered D/A converter. You count into it and it produces 2-1/12 times a reference voltage, which you can set with a pitch knob. As it counts by 1, then it goes to 2-2/12 times the reference voltage, then the next increment is 2-3/12, and so on, so that you are generating a control voltage which by its very nature is equally tempered and exponential in character. You don't have to start with a linear control voltage, and then bend it around with an exponential converter inside the oscillator. One thing you want to do with a computer is control large numbers of oscillators—ten or a dozen or more—and four or five filters, too—you're not controlling them with your fingertips, but rather, you're telling the machine what you want them to do. If you're going to go with an exponential setup, then you have to have an exponential whizbang on each and every oscillator and filter in the system. It's a little added thing that everybody thinks has got to be there, but it *doesn't* have to be because the D/A converter takes care of that in the first place. You can then save a lot of expense

with the oscillators; one of the products we're working on now is a quad VCO, for instance, that will go for about what one of our single VCOs goes for now. It will be about \$8 per VCO—not bad at all.

Synapse: *This is a good point to get into another question. Obviously you're into the design end of things; although musicians are real happy to build other people's circuits, they want to come up with their own stuff. What do you recommend?*

John: I'd recommend they buy themselves an \$89.95 Eico or Heathkit scope, and as many parts as they can lay their hands on, and start to play. In my opinion, and I think a lot of people involved in design would agree with me, that's the only way you really learn it.

Synapse: *But a lot of people aren't going to know what to do with the parts once they have them.*

John: Well, that's why they go to books like yours, for instance. And that's why they'd go to *Poliphony*. But you've got to start some place, and there will be things you don't understand. They're not going to learn it from the engineering schools I went to. I learned a lot of analysis and it seems that's predominantly what they want to teach people. Analysis is fine if you're going to be a bench tech, but if you're going to be a designer the only way is to do it and see why things go wrong—why they don't work—there's a lot of head scratching involved.

But in the process, you've learned a lot. Another part about being a designer is that a designer is a lot like a performing artist; he builds up a repertoire of things that he's familiar with—certain circuit blocks. Everybody has a set of things they're comfortable with. They know the limits, what they do and what they don't do, so why redesign the wheel every time you sit down? But do you know where analog circuit designers are headed—we're headed for obsolescence, because of digital. Everyone, I am sure, involved in the design of synthesizers today knows where that field is headed—towards the day when there are no analog elements to speak of in a synthesizer at all—we're headed for the day when a large digital computer by today's standards takes care of generating all the needed waveforms. Unfortunately that large and that fast a machine isn't available today, and that's why we're getting by.

Synapse: *Won't extremely cheap memory be required, though?*

John: Well, I still run into people who say all this will never happen—never have big machines on a chip—they're kidding themselves. Of course we'll have it. Several years ago, many people would have said no way to the concept of a computer on a chip, but we have them.

Synapse: *When it gets to that level, it won't be hard to apply either. For example, I could certainly build a calculator now—one*

chip, a display, and keyboard—but ten years ago, I couldn't have done that. This solves the problem for all those people who want to design things: they just plug inputs and outputs together in whatever way they want.

John: That's where it's headed; it's not getting more difficult to design, it's getting a lot easier thanks to integrated circuits.

Synapse: *When you were talking before about a computer to drive things, were you thinking of a separate, dedicated computer for the synthesizer, or do you assume everyone will have a computer and this will hook up to it?*

John: We've gone about it, naturally, a little bit differently. We're essentially going to come out with two products: a computer trainer, very similar to a KIM-1 (a popular microprocessor teaching tool), except it will be a cut down version and sell for about \$125. Displays, keyboards, monitor in a PROM—the whole shooting match. People can use that processor itself to learn about microcomputers, understand how the registers change back and forth and so on. But as it turns out, the machine is the right physical size—and has just the right connectors on it—that it can slide right up into our keyboard case, the D/A converter plugs in, and we put in a ROM with software. People are used to working with synthesizer modules; they know what a filter or ring modulator does. It is a hardware module they tie together with patch cords. We're going to give them essentially the same thing with the computer, except instead of a hardware module, they have software modules to feed the keyboard, send data out to the oscillator, store data in memory, bring it out again—transpose—delay—all of these modules are set up as subroutines—something you bounce into, and when you're done, it bounces you back exactly to where you came from. In the first machine, the instructions are entered on a hexadecimal keyboard. But a later machine on the drawing boards has got individual keys for each of those software modules.

Synapse: *Almost like the stops on an organ.*

John: But a lot more versatile. And in the ultimate system, you have a CRT, ASCII keyboard, disc drive to store your programs.

Synapse: *And it prints out a lead sheet and addresses an envelope to the copyright office.*

John: Why not? ~~~

Synapse

BOW YOUR GUITAR

with The First Electronic Bow For The Guitar — the **E-Bow**

Tired of the same old show? Picture what a violin bow does for the violin . . . the range of sounds, the dynamics, the life the bow gives the violin. Imagine what you could do with a device that would bow your guitar string electronically . . . the Energy Bow.

Hand held, the E Bow is swept over the string to control harmonics and envelopes, allowing the guitarist to shape the sounds of violin, flute, cello, oboe, horn, synthesizer, and reverse tape effect. Total control of attack, sustain and decay at any volume.

Not a pedal or plug in . . . the E Bow is battery powered, completely self-contained. No hook up. Emitting an intense magnetic field, the E Bow operates directly on the guitar string NOT ON THE SIGNAL FROM THE PICKUP. You owe yourself, your music, and that lonely old axe of yours the chance to come alive. EXPLORE A WHOLE NEW DIMENSION. INFINITE SUSTAIN and so much more!!! Get to your music store for a live or taped demo. NOW.

SPECIAL OFFER — HEAR THE REMARKABLE E BOW

For Demo cassette send \$1.00 U.S. to cover postage and handling to:

E Bow T-Shirts: \$4.50
plus 50c to cover postage
and handling. (S, M, L)

Heet Sound Products
611 Ducommun Street
Los Angeles, Ca. 90012
Phone: (213) 687-9946

Distributed in Australia by:
The Music Distillery
Brookvale, N.S.W. 2100
Phone: 938-2372



Increase your
SYNTHESIZER'S
capabilities many fold
with the
Control Voltage Processor

DENNIS Electronics
2130 Metcalf Street, Honolulu
Hawaii 96822

by Craig Anderton

Musicians often have the dream of owning a recording studio in their own home. The introduction of comparatively inexpensive multichannel tape equipment for consumer applications has made this dream a reality for many people. Being able to layer several tracks of instruments means that an individual musician, using a synthesizer or a number of traditional instruments, can build up entire pieces of music.

Probably the most common home studio track configuration is four tracks, since 4 track recorders are considerably less costly than 8 track units and use common, relatively inexpensive tape. Unfortunately, sometimes 4 tracks seems very limiting, especially if you are one musician trying to get a symphonic sound. Fortunately, it's not too hard to get up to 8, 9, or even more tracks out of your machine if you do a little advance planning and plot out track assignment strategies as you do your recording. Best of all, you don't have to suffer too much in terms of quality for these extra tracks if you record carefully; and, in the following examples, you don't even need a second machine . . . all these tricks may be performed on a single 4 track recorder.

Before we get into the actual techniques, let's look at some of the equipment needed to get off the ground.

1

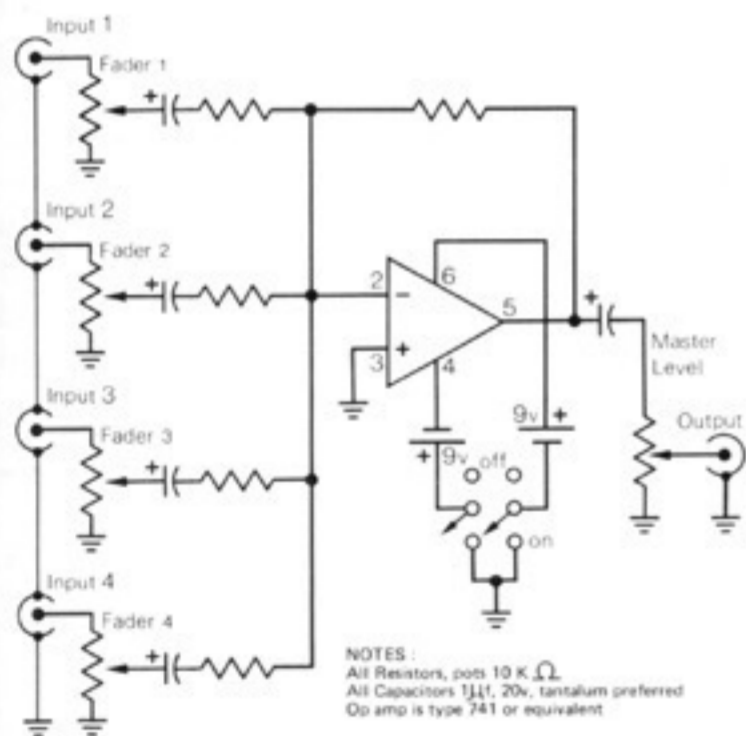

Required materials: First, you will need a four track recorder that can handle tape at 15 IPS. 7½ IPS is acceptable, but far less desirable. 3.75 IPS is pretty much out of the question if you are looking for quality sound. Next, you will need a 4 input, 1 output mixer to mix signals into your tape unit and to mix the outputs of your tape channels into a monitor amp or other channels of the tape recorder. You will also need patch cords to get from the tape machine to your mixer, and from whatever instruments you are using to your mixer.

Incidentally, you do not need anything particularly elaborate for a mixer. If you have a simple instrument or PA mixer it will probably do the job, as will several of the

Generating more tracks from Four Tracks.



projects I have written up (see project No. 18 in *Electronic Projects for Musicians*, the projects chapters in *Home Recording for Musicians*, and *Contemporary Keyboard*, June '77 issue, "Design and Build Your Own Keyboard Mixer") or follow the schematic given in figure 1.

Optional equipment includes a low noise, high gain preamp for running low level signals (like guitar pickups, microphones, etc.) into the line inputs of your recorder, and a low Z to high Z impedance matching transformer so you can match low impedance devices to the high impedance inputs of your mixer (assuming it doesn't already have low impedance inputs, of course).

So much for what you need. Before picking up an instrument, though, it's time for the rules of the game.

Guidelines for best results

In order to obtain all these extra tracks we need to run the recorder near its limits of performance, so every step we can take to minimize noise and distortion will yield important dividends when the piece is over. We will be *ping-ponging*—playing back some tracks of the recorder into other tracks of the recorder—and this builds up noise in a hurry if care is not applied at every level of the recording. Therefore, we have to follow certain guidelines to obtain a reasonably good sound.

1. Run your tape at 15 IPS. While the difference between 15 and 7½ IPS may not seem so great on a single track, after building up multiple tracks the higher speed makes a very significant and obvious difference in terms of reduced noise and increased headroom.

2. Use the best tape you can afford. The manufacturer of the tape recorder will have biased the machine for a particular tape, which is often recommended in the instruction manual. Using the recommended tape usually gives best results. Don't use house brand tape, or dime store tape, or any of that bargain basement stuff.

3. Keep your recorder in top condition. The heads should be thoroughly cleaned and regularly checked for magnetization; if magnetized, they should be demagnetized. The tape path should also be clean and free from shedded tape oxide. Don't forget to clean the capstan and pinch roller, but be careful—some head cleaning solutions will crack the rubber of the pinch roller.

4. Hit your tapes with the highest signal levels possible. The further you get above the noise short of distortion, the better your end results. Don't necessarily believe the meters—some sounds may look like they are peaking lower than others, but distort on playback nonetheless. Get into the habit of monitoring from the tape occasionally so you can check for distortion on the tape.

2

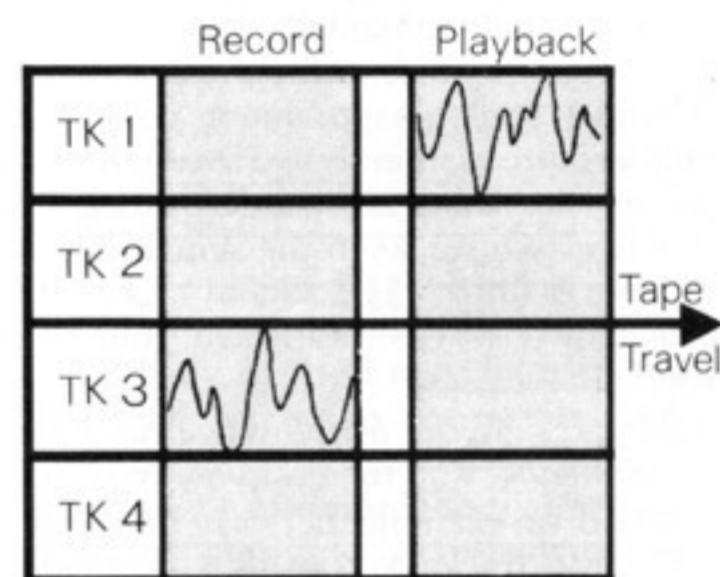

Tracks recorded out of sync.

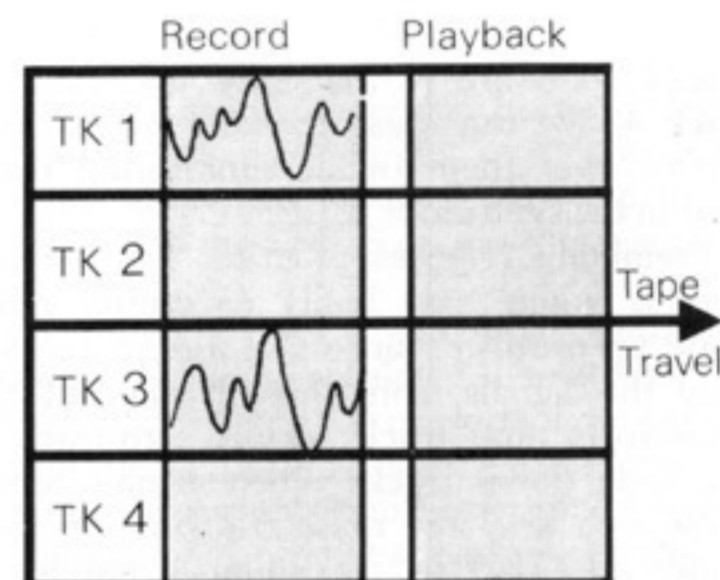

Tracks synched at record head.

ILLUSTRATIONS BY SUE DENIM

5. The tape recorder must be able to monitor the channel output either from the playback head or the record head. This is very important. Let's say you record a signal on your tape and listen to it on a playback head. Now, let's say you record another track, which gets impressed on the tape at the record head. Note that these sounds are not at the same place on the tape (see figure 2)—when you listen to both of them, the first sound will hit the playback head before the second one. However, if you lay down the second part while monitoring the first track at the record head (known as *sync* mode), then sounds are at the same place on the tape upon playback.

....Four Tracks.

The purpose of these rules is to keep the noise down and the quality up. Towards this end, accessories like noise reduction, pre-emphasis and de-emphasis, and noise gates can help clean up your sound considerably. But keep in mind that no extra equipment is *necessary* to make your tape; it's just nice to have quality-enhancing options.

Generating more tracks: First, let's touch briefly on generating less than 4 tracks. If you only need a 2 track recording, then it is usually better to use a 1/2 track machine since it will probably have better noise characteristics and greater head room compared to using 2 tracks of a four channel recorder. So, if you don't really need a 4 track recorder, don't use it.

4 tracks: This is simple, but we will go over it anyway. Simply plug into input 1 and record. Then, go back to the beginning, listen to channel 1 in the sync mode so it's being monitored from the record head, and lay down another track into track 2. Then, listen to the first two tracks in the sync mode, and lay down a third track. Finally, listening to the first three tracks, lay down your fourth track.

6 tracks: (see figure 3.) Now we have to get into *premixing*, and the best way to illustrate this is with an example. Let's say you have recorded into tracks 1, 2, and 3 in a fashion similar to the procedure given in the last paragraph. Normally, you would only have one more open track to play with. But, we can pre-mix tracks 1-2-3 into track 4—which means that since the signals recorded on tracks 1-2-3 are permanently preserved in track 4, we can erase tracks 1-2-3 and re-record over them (while monitoring track four in the sync mode).

Premixing requires practice. First of all, here is where you really encounter noise build up problems since you are mixing not only the signals from three tracks but the noise from three tracks as well into track 4. So, fade down tracks when signals aren't present to keep the noise contribution to a minimum. Try for maximum signal level, follow all the other tips given earlier for keeping the quality up.

Also, remember that once signals are pre-mixed on to a basic track, you are committed to that particular balance for the remainder of the tape. For example, say you have recorded drums, bass, and piano into tracks 1, 2, and 3, and mixed them down into track 4. You now have three tracks sitting in track 4, so you may erase the previous tracks and record a fourth track in track 1 and a fifth track in track 2 . . . maybe even a sixth track in track 3. Great; now you have man-

3

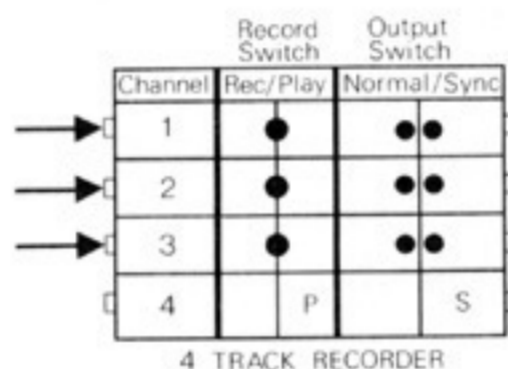
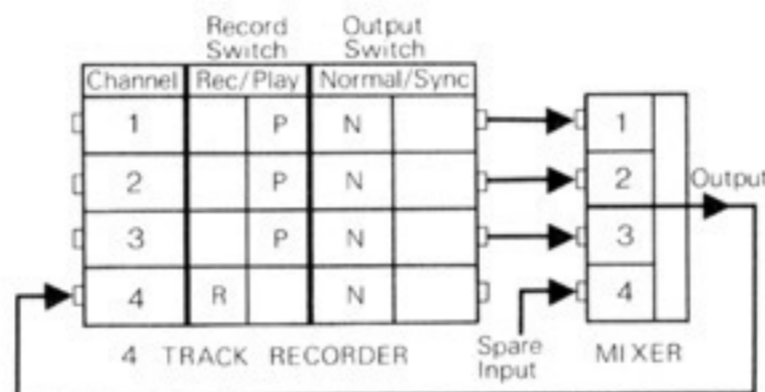

aged to squeeze 6 tracks out of your four track recorder. However, let's say you now want to mix these various tracks down on to a second machine for a final master. If you happen to have hit the right balance in your premix, that's just fine . . . but if you didn't, there is no turning back; you cannot go and unmix your premix and start all over again. For that reason, before proceeding to record any extra tracks take the time to make sure the premix is as close as possible to ideal. Granted, it is not easy to know how to mix early tracks without the later tracks for comparison . . . but luckily, with a little practice you will be able to anticipate your long-range needs when you premix.

7 tracks: This is a little trickier, and involves mixing another track in with your premix. Let's take the same situation as before: drums, bass, and piano mixed into tracks 1, 2, and 3. Again, we want to mix those into track 4. But note that there is an extra input with a 4 input mixer—and we can plug an instrument into that input and play along with the three previously recorded tracks as we premix them into track 4. This gives us four tracks sitting in track 4 after the premix is over. It's a little difficult to play and mix at the same time, perhaps, although certain parts lend themselves to this approach (such as occasional percussion, sound effects, harmony voice parts, etc.). Once the premix

is recorded, you can re-record over tracks 1, 2, and 3 for a total of 7 tracks.

8 tracks: (See figure 4.) The procedure for obtaining a premix is the same as the last example, with the end result being four tracks sitting in track 4. This time, though, after recording parts into tracks 1 and 2, we premix them into track 3 of the recorder. This gives us 4 tracks sitting in track 4, 2 tracks sitting in track 3, and we still have two tracks left over for a total of 8 tracks. However, when playing back track 3 for mix-down, it must be in the *sync* mode so that you are monitoring from the record head. In the process of recording those two tracks into track 3, we created a slight time delay with respect to the basic track. Playing track 3 back in the sync mode alleviates this problem. When recording over tracks 1 and 2, listen to track four only, in the sync mode. If you try to listen to track 3 there will be no way to get all the tracks synchronized, so once you have mixed tracks 1 and 2 into 3 leave it turned down until final mixdown.

9 tracks: This requires the same procedure as above, except that when you record tracks 1 and 2 into track 3, you add another part along with this premix. I use this technique a lot with vocals, where I will record two voice parts into tracks 1 and 2, and mix them into track 3 along with a harmony part.

So there you have it, how to get lots of tracks from a 4 track recorder. These techniques work with all the four track machines I have tried, and they should work for you. Chances are the first time you try this stuff you may have some confusion concerning when to monitor from the playback heads, when to monitor in sync, and how to premix. But practice makes perfect, and a tape recorder is like any instrument—the more you play it, the better you get. So, enjoy yourself as you construct your music, and rest assured that as time goes on your tapes will sound better and better. ~~~~

4

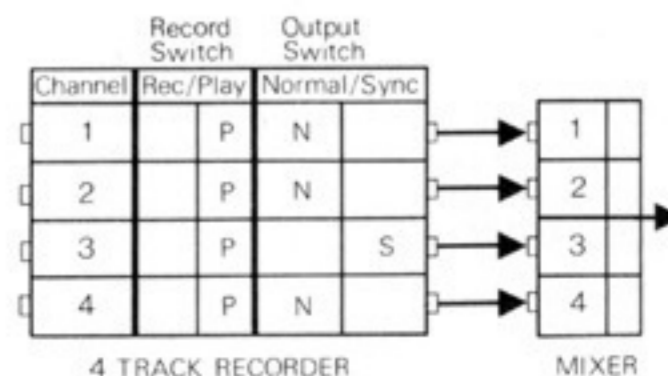
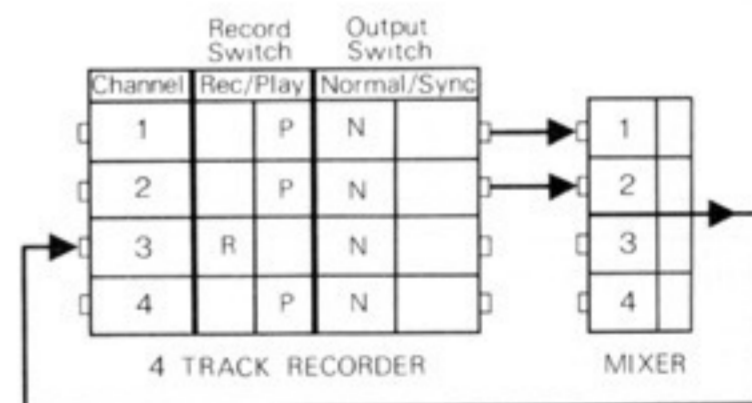

If your knowledge of Synthesizers goes beyond the front panel, you really should know about us, we offer plans, kits, parts, and a whole lot more!

Write for free information

SPECIAL THIS MONTH ONLY

TAU SYSTEMS 1005 VCO KIT

only \$18. exponential 1volt/octave, Triangle & Square

CFR ASSOCIATES
box F
Newton N H 03858

FOR A GREAT AUDIO ADVENTURE

A new, exciting discovery in great sound awaits you in *THE AUDIO AMATEUR* MAGAZINE.

It's delightfully easy to improve, maintain, and even build your own audio components. Thorough articles—everything from amps to speakers, simple add-ons or improvements to intricate modifications—help even our non-technical readers develop superior sound equipment.

Subscribe now on a guaranteed satisfaction basis or send for our **FREE** prospectus.

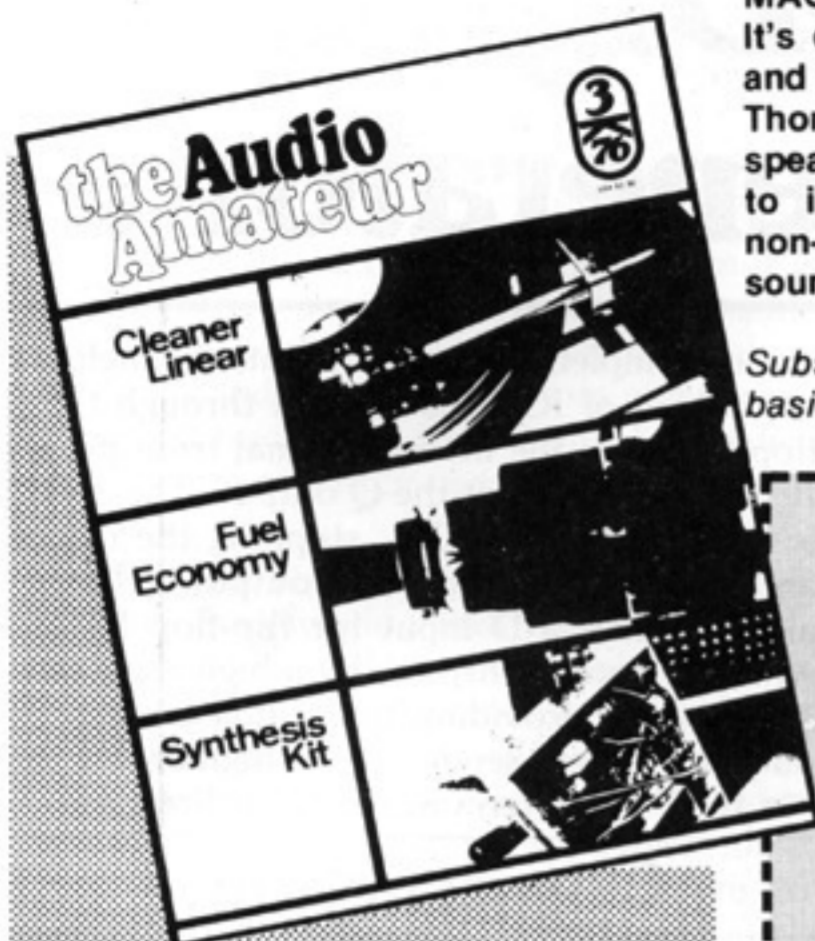

HANDY COUPON

Fill in the coupon, include a check or money order payable to *The Audio Amateur* and send to TAA Dept. S1, Box 176, Peterborough NH 03458 USA.

- Enter my sub for TAA for one year/four issues for \$9.
- I want to know more. I enclose \$2.50 plus .50 cents postage for the current issue of *The Audio Amateur*.
- Send free prospectus.

Name _____
 Street _____
 City _____ State _____
 ZIP _____

Foreign subscriptions are \$10 per year and all remittances must be in US funds.

Digital Pattern Generator

sequencer, that several leds may be on at once. In this case, the control with the highest level determines the output voltage.

If all leds light, the sequence will be at its end; and if all are unlit, the sequence will be at its beginning. This is a good way to observe sequence direction.

Voltages at the up/down and gate/trig inputs should be at least 70% of the positive supply voltage, with ground initiating down counting and a positive voltage, a gate or trigger.

When first applying power to the module with the gate/trig input connected, the sequence may not start. In this case, briefly disconnect the input.

The up/down toggle switch can be used as a direction control when the Pattern Generator is running continuously.

An external voltage controlled clock can be substituted for the built in one by breaking the connection between pin 15 IC 1 and pin 4 IC 6; then applying the external clock through a 10 K resistor. The clock must have fast rise and fall times and have a level of at least 70% of the DPG positive supply voltage.

Coming soon will be a voltage controlled clock which can be used with the DPG or any other sequential device. In the meantime, see (hear) what dimensions of sound are accessible with this project. 

*Guitar Player Productions: P.O. Box 615, Saratoga, Ca. 95057

Parts list:

- IC 1 4516 CMOS up/down counter
- IC 2 4013 CMOS flip-flop
- IC 3 4001 CMOS quad nor gate
- IC 5 741, 5558, or 4136 op amp (see text)
- IC 6 4069 CMOS hex inverter

Resistors, 1/4 watt.

- 6 1K
- 2 10K
- 1 20K
- 4 100K
- 2 1M

Potentiometers, linear.

- 1 5M
- 5 50K
- 1 10K

Capacitors.

- 1 .1 uf mylar
- 1 270 pf polystyrene or ceramic
- 3 .047 or .05 ceramic
- 2 1.0 uf electrolytic

Miscellaneous.

- 4 IN4198 diodes
- 1 SPST toggle switch
- 4 1/8" jacks
- 4 LEDs

EMSA

MOOG

OBERHEIM

ARP

EMS

NEW

USED

269 LOCUST STREET, NORTHAMPTON, MA. 01060

TELEPHONE (413) 586-3777

THE BEAT GOES ON

Combination tones and temperment.

by Jon Dattorro

The synthesizer generates sound by manipulating the very roots of sonic phenomena. Its progression from the present state of the art into the mysterious future depends upon the knowledge the user has assimilated concerning all aspects and idiosyncrasies of his instrument, and the depth of his perception. Although it was originally designed as a musical instrument, the voltage-controlled synthesizer is theoretically capable of reproducing any sound imaginable.

Music is composed of sound, but not all sound is music. The discussion which follows attempts to elucidate some of those "sonic roots" and their relation to music. Hopefully, at the same time, the reader will become aware that a compulsory adherence to any one musical system is now as stifling a limitation as would be the use of the synthesizer for only musical purposes.

When a single sound source such as a flute produces a tone, the air surrounding the flute is made to vibrate in a specific manner such that if our ears are in proximity to this vibrating air, the mechanisms of our ears will be caused to vibrate sympathetically, producing a sense of pitch within our brains. A simple mode of vibration may appear as in Figure 1 in its symmetrical compression and rarefaction of the air. Some tones in the upper range of the flute very closely resemble the waveform of Figure 1 which is called a *Sine Wave* (from the Latin *Sinus* meaning "curve" or "hollow"). Figure 1 then, is just a graphic representation of one way air molecules may be compressed and rarefied with time. Pitch is determined by the frequency of a repetitive waveform: that is, the number of vibrations per second.

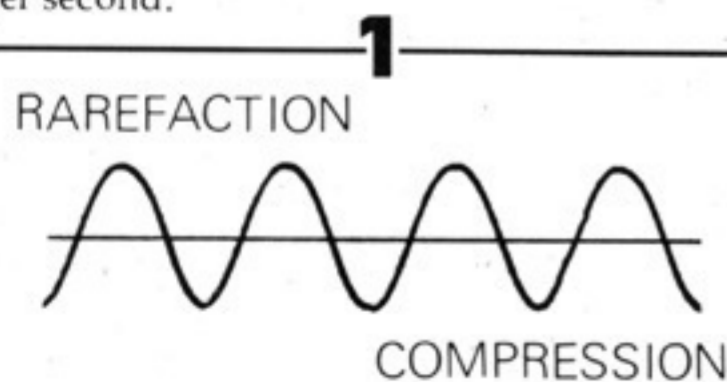

More complex tones than those of the flute are heard frequently in the sounds of the other orchestral instruments. For example, playing a tone on the violin produces a waveform which is a composite of many sine waves of varying intensities and at multiple frequencies of the perceived pitch; thus, the violin possesses a timbre uniquely its own as

the result of its particular composite. Using sine waves as building blocks then, we can see that it becomes possible to create an infinite variety of timbres by combining any number of them in almost any way.

A description of the way in which the individual component-sine waves of a tone are combined is called the *Spectrum* of that timbre. The frequency of the lowest component-sine wave (fundamental) of a particular spectrum usually, but not necessarily, determines the frequency of the perceived pitch of that sound spectrum, even in the case of tones produced by conventional orchestral instruments. The reason for this is that the way in which the entire spectrum of a sound interacts in the air becomes more important to our ears than just the lowest (or relatively loudest) single frequency component present.

The internal modulation of a spectrum with time as well as resonance of vibrating bodies are also factors which determine timbre, but it is still first a function of the pitch components within a spectrum. It should be clear then, that a thorough discussion of timbre involves all parameters of sound.

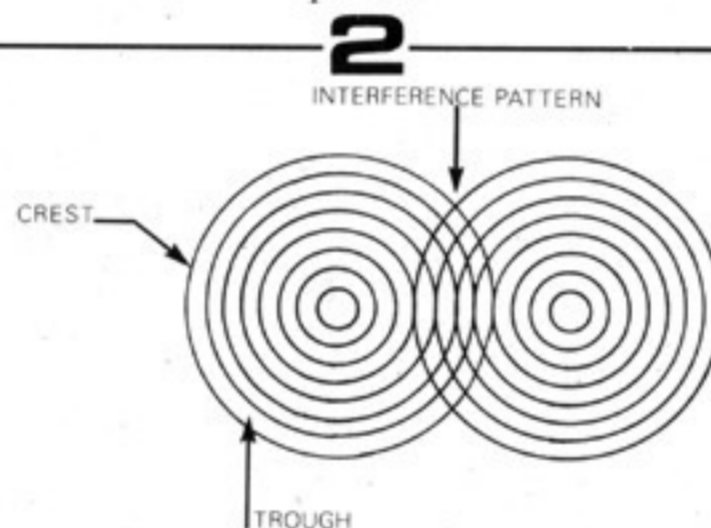

When any number of tones are sounded together, interesting wave patterns are created in the medium surrounding the sources, such as air, through which they travel. These resultant patterns are called *Interference Patterns* and can be observed directly by simultaneously dropping two pebbles a certain distance apart, into a calm pool of water (Fig. 2) and noting the pattern caused by the meeting of the crests and troughs of the water waves as they attempt to propagate through the water unhindered as if no obstacles or other wavefronts were present. These waves in the water surprisingly enough produce almost no current; that is, the only movement of *water* that takes place is up and down not across. The waves themselves, however, do appear to be moving across the water in this case and indeed they do. The reason for this is that the up and down movement of the water does not happen simultaneously at all points but happens sequentially across the entire

surface of the water thus causing the waves' transverse movement. (Fig. 3) A wave generated at one side of a pond then, will undoubtedly reach the other side in a certain amount of time.

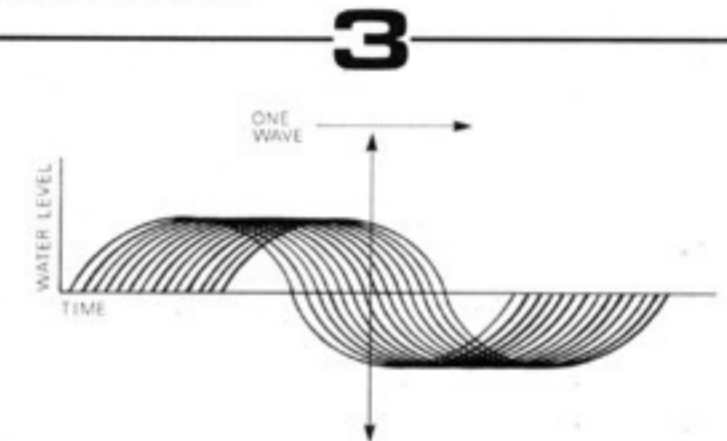

Air waves interact in a similar fashion except that sound waves as in the case of the flute, tend to propagate spherically as opposed to the two dimensional circular propagation of the waves on the water's surface. This accounts for the fact that we are able to hear the flute even if we are standing in back of the player. Of course, if both listener and player are in the same room there will be multiple reflections of the sound waves off the walls making the flute louder than it would be outside in an open field.

Providing that two or more tones are sufficiently present relative to each other and they occupy the same space, and given that their pitch-frequencies are slightly different, the phenomenon known as *Beats* will occur. Beating occurs as a result of the *Interference Pattern* produced by the combination of closely related waveforms (Fig. 4).

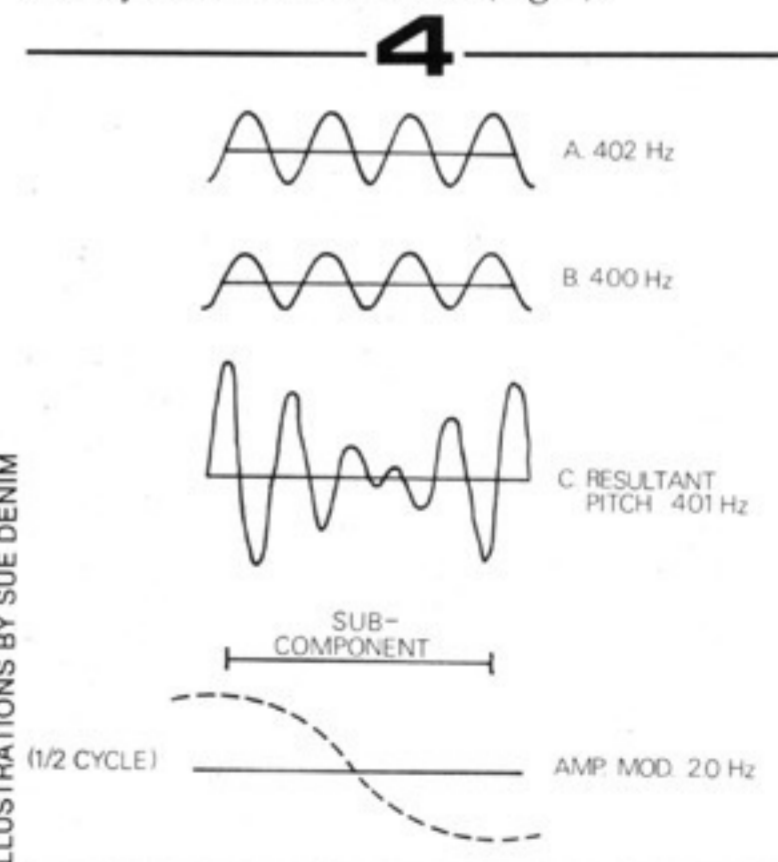

The addition of the two waveforms A and B in Figure 4, results in the new waveform C. Since the height of the waveforms in Figure 4 represents their amplitude, it can be seen that

**ELECTRONIC MUSIC:
IN-HOUSE PRODUCTION
SCORING/ARRANGING
RECORDING • RENTAL
SALES • CONSULTATION
INSTRUCTION • 2825
HYANS ST. LOS ANGELES
90026 • (213) 487-5148**

Sound Arts

the amplitude of C modulates from an amplitude which is greater than either A or B to an amplitude which is greater than either A or B to an amplitude which is less than either A or B. We may conclude from this that *Beating* is a form of *Amplitude Modulation (AM)*, and what we hear is not the separate individual waveforms but rather a new composite waveform, the *Interference Pattern*. Also, the frequency of amplitude modulation heard in the interference pattern will be equal to the difference in frequency between the waveforms involved, and the overall pitch perceived will be the average pitch-frequency of those same waveforms.

— Continued next issue. —

Synapse

**N.Y.'S DISCOUNT
MUSIC DEPT STORE**
JUST A FREE CALL AWAY!
800-645-3518
SAM ASH MUSIC STORES

Buy at discount direct from our 6 huge stores and warehouse. All musical instruments, amplifiers, electronic keyboards, discos, PA's, pianos, organs, accessories, music. Call for prices or mail your list of questions. NYC area residents, please visit us in person. NY state phone 212 347-7757. Since 1924

ARIES MUSIC
INCORPORATED

What's the connection here?

Almost every synthesizer has a keyboard, but not every keyboard player is a synthesist.

Aries makes modular systems for the musician who considers the synthesizer to be his primary instrument. Modular design allows complete control over pitching and normalled connections—thus each player can achieve a personalized repertoire of sounds.

Every Aries system is a custom design because every customer gets involved: choosing from our kits, modules and cabinets the kind of system he wants to use.

So if you play the synthesizer, and not just the keyboard, we think you've already made the connection. Call (617) 744-2400, or write:

Box 3065 Salem, MA. 01970

JINKS N' POINTS IN THE HIGH HISTORY OF ELECTRONIC MUSIC MUSIQUE CONCRETE

THE SCENE IS THE STUDIOS OF RADIODIFFUSION-TELEVISION FRANCAISE..PIERRE SCHAEFFER (THEN 34) IS ANNOUNCING THE LIBERATION OF PARIS! HE IS READING FROM VICTOR HUGO AND PLAYING LA MARSEILLAISE!

ASSEZ DE JONTE! REDEVENIR LA GRANDE FRANCE



ON RESPONSE TO HIS CALL THE CITIZENS OF PARIS OPENED THEIR WINDOWS AND SANG ALONG WITH THEIR BROADCASTER!

AL-LONS EN-FANTS DE LA PA-TRI-E!



THOUGH TRAINED AS AN ENGINEER, SCHAEFFER COMPOSED A "CONCERTO OF LOCOMOTIVES" BY RE-RECORDING SOUNDS OF TRAINS USING ONLY DISCS. HE PRODUCED "ETUDE AUX CHEMINS DE FER", PROBABLY THE FIRST PIECE TO EXIST ONLY AS A RECORDING

SCHAEFFER WAS AWARE OF PRECEDENTS... 1913: RUSSOLO'S BOOK THE ART OF NOISES. 1930's: HINDEMITH AND TOCH'S EXPERIMENTS WITH SPEEDING & SLOWING RECORDINGS...



SCHAEFFER USED THE TERM "MUSIQUE CONCRETE" BECAUSE THE SOUNDS WERE "REAL" AND RECORDED FROM THE ENVIRONMENT.

ON 1951 THE RTF FINANCED THE FIRST STUDIO DESIGNED FOR ELECTRONIC COMPOSITION. IT HAD TAPE RECORDERS, TAPE LOOP PLAYERS, ADJUSTABLE FILTERS, VARIABLE SPEED PHONOGRAPHS, AND OTHER SPECIAL DEVICES DESIGNED BY ENGINEER JACQUES POUILLIN.

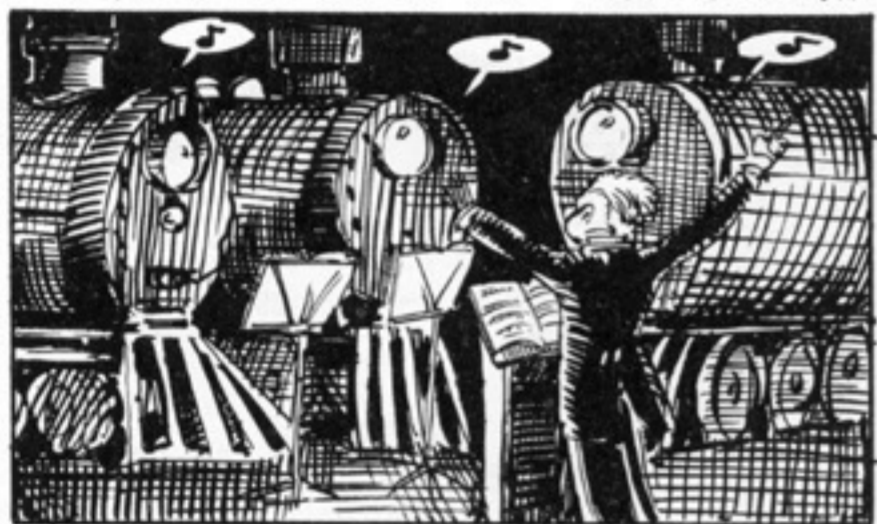

SCHAEFFER BEGAN COLLABORATING WITH THE YOUNG PARIS CONSERVATOIRE TRAINED COMPOSER PIERRE HENRY IN 1949 THEIR FIRST COMPOSITION WAS THE SYMPHONIC POUR UN HOMME SEUL. THEIR OPERA, ORPHEUS, WAS PERFORMED AT THE DONAUESCHINGEN FESTIVAL IN 1953. THE HORRIFIED AUDIENCE AND PRESS FOCUSED ATTENTION ON THE COMPOSERS!



Here's the deal.

You send us the money, we ship you the product, in a box, fast.

You're looking at our beautiful showrooms. To get prices down this low, we've had to eliminate all the typical sales overhead. No demonstrations, brochures or catalogs. You know what you want. We know we can sell it to you for less.

We're one of the largest national dealers for leading lines of musical instruments. All warranties offered by the manufacturers are honored whether unit is shipped in the box or from our checkout floor.

If this unusual offer sounds good to you, all you've got to do is order.

To Order

Send a cashier's check or money order for the full amount. (Sorry, you'll have to arrange for financing on your own.) Specify exactly which item you want by brand name, model number.

We will ship immediately. Freight charges will be collect — payable by you when you receive the item.

California residents add 6% Sales Tax.



	Suggested List	Our Price
ARP Omni 2600	2395.00	1488.00
Axe	3195.00	1988.00
Odyssey	995.00	588.00
DGX	1695.00	988.00
String Ensemble	1295.00	788.00
	1995.00	1188.00



	Suggested List	Our Price
CAT 2 Voice	849.00	599.00



	Suggested List	Our Price
MOOG Polymoog	4495.00	3195.00
Mini Moog	1795.00	1088.00
Percussion Controller	265.00	188.00
Poly Pedals	295.00	209.00

	Suggested List	Our Price
FENDER Rhodes Piano		
Stage 73 Piano	925.00	647.50
Stage 88	1095.00	769.50
Suitcase 73	1375.00	969.50
Suitcase 88	1545.00	1088.00
Key Bass	525.00	367.50
Satellite Speaker System	975.00	682.50



	Suggested List	Our Price
YAMAHA CP 70 Electronic Baby Grand	3100.00	†
CP 30 Electronic Piano	1295.00	†
YC 45D Most Advanced Dual Manual Portable Keyboard	2975.00	1995.00
YC 25D Dual Manual Organ	1375.00	949.50
YC 20 Single Manual	895.00	599.00
YC 10 Stager Single Manual	595.00	399.00
SY 2 Synthesizer	995.00	588.00
Pedal Bass for the above models	200.00	134.00
PM-1000-32 (demo)	13,800.00	7995.00
PM-1000-24 (demo)	12,000.00	6995.00
PM-1000-16 (demo)	6950.00	3995.00
PM-1000-32	13,800.00	10,300.00
PM-1000-24	12,000.00	9000.00
PM-1000-16	6950.00	5200.00
PM-700	2695.00	2000.00
PM-430	1095.00	820.00
PM-170	495.00	369.00
P-2200 Power Amplifier	895.00	719.00
EM-150 Mixer Amplifier	640.00	448.00
EM-100	439.00	307.00

	Suggested List	Our Price
EM-80	339.00	239.00
SO-112T	225.00	159.00
S4115H	375.00	265.00

	Suggested List	Our Price
FARFISSA VIP 600 Two Manual	1998.00	1498.00
VIP 500 Dual Manual	1545.00	1149.00
611 Matador (demo)	895.00	599.00
Mini Matador	550.00	425.00
VIP 345 Single Manual	1245.00	869.00
Professional Piano (demo)	1050.00	735.00
Syntorchestra Stereo Preset Synthesizer (demo)	995.00	688.00
VIP 370 Single Manual Organ	1250.00	939.00

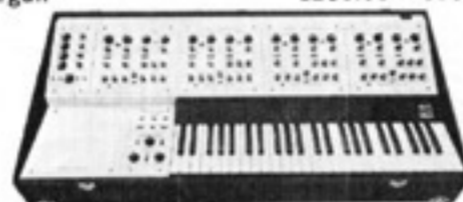

	Suggested List	Our Price
OBERHEIM 4 Voice Polyphonic with Programmer	5690.00	3799.00
2 Voice with Mini-Sequencer	2195.00	1469.00
Digital Sequencer	1295.00	869.00
Synthesizer Expander Model	695.00	469.00
Mini Sequencer	495.00	339.00



	Suggested List	Our Price
BOSE Bose speakers w/eq. 850/pair	850.00	588.00

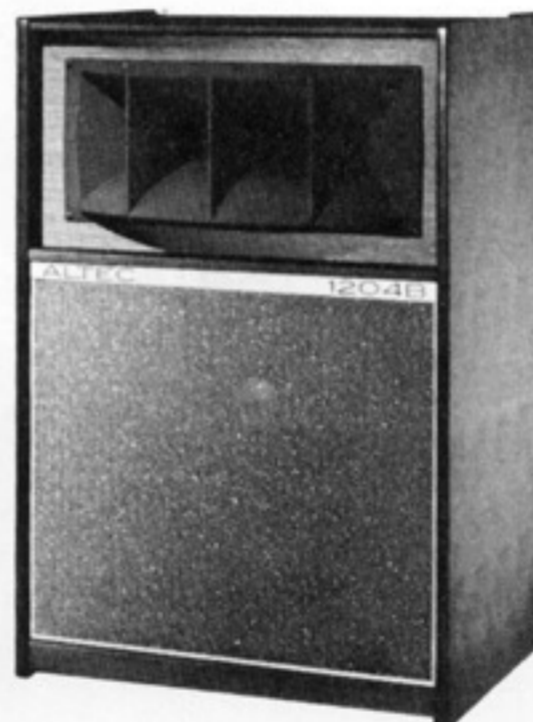

	Suggested List	Our Price
ALTEC 1204B Voice of the Theater	760.00	456.00
1217A Column	560.00	336.00
1221A Stage Monitor	596.00	359.00



	Suggested List	Our Price
SHURE SM 57	99.00	79.20
SM 58	126.00	99.00
PE 50SP	217.00	109.00
PE 54D	142.00	69.00
PE 56D	156.00	79.00
PE 588	92.75	49.00

	Suggested List	Our Price
CROWN DC 300	849.00	†
D 150A	499.00	†
D 60	299.00	†

	Suggested List	Our Price
AMPEX 456 Grand Master 1/2" Tape	45.00	24.88

	Suggested List	Our Price
DBX DBX 154	750.00	†
DBX 160	315.00	†



	Suggested List	Our Price
ELECTRO-HARMONIX Electric Mistress	199.95	79.95
Maestro PS 1A Phase Shifter (close-out)	199.95	69.95



	Suggested List	Our Price
TEAC A-3340S	1200.00	849.50

	Suggested List	Our Price
TEAC TASCAM Series Model 1 Mixer	150.00	127.50
Model 2 Mixer	350.00	288.00
Model 3 Mixer	900.00	757.00
Model 5A Mixer	1650.00	1427.00
80-0 8-Track Recorder	3000.00	†
25-2 2-Track Mastering Recorder	2000.00	†
PB 64 Patch Bay	92.85	78.00

	Suggested List	Our Price
CRUMMAR Portable Organ (sound of B3)		
Traveler 1 Organ	1195.00	888.00
Traveler 3 Organ	2295.00	1688.00
Multi Man	1299.00	948.00
Road Runner pedal bass unit	550.00	418.00
Pedal Bass	295.00	218.00

	Suggested List	Our Price
Hohner Clavinet	1095.00	788.00
String Vox	1195.00	888.00

	Suggested List	Our Price
ELKA String Choir ELKA 490	699.00	499.00

	Suggested List	Our Price
MXR 10 Band and 6 Band Graphic Equalizer		
10 Band	139.95	79.95
6 Band	79.95	49.95
MXR Digital Delay	999.95	699.00

	Suggested List	Our Price
LESLIE Model 147	745.00	488.00
Model 122	745.00	488.00
Model 760	894.00	588.00
Model 910	1174.00	788.00
Model 925	1882.00	1288.00

Half Price Sale

	Suggested List	Our Price
KUSTOM (demos) MF 1212 Folded Horn Enclosure	550.00	225.00
MF 1012 Radial Horn	650.00	325.00
10 Stereo Power Amplifier	399.00	199.50
6 6-Channel High/Low Impedance	799.00	399.50
FLH 15 PA Cabinet	400.00	200.00
M 15 Mid-Range Horn	190.00	95.00

† Call for price.

Prices subject to change

Limited quantities of some items.

Written copies of warranties available.

AMCOM ENGINEERING

1015 Seventh Avenue
San Diego, Calif. 92101
714/239-1979

EQUIPMENT



A/DA Flanger

I don't know about you but the manually variable LFO's built into many "outboard" audio processors have made these devices an unattractive means of processing the signals from my synthesizer. Why? Because for years I've been enamored by voltage control: The ability to create the rise and fall and the points in between and vary them in real time. Even when dealing in an arhythmic situation often one must still create a predictable or predictably variable voltage control system to attain the required sonic result.

It can only be frustrating if not down right backwards to subject your output to a periodically changing voltage (or effect depending on your frame of reference) which operates without regard for the aesthetic considerations of your original patch. It is for this reason that I have never considered the purchase of 99-9/10% of the outboard equipment marketed to the hordes of sonic aficionados. Never would I allow a beautiful sustain to be interrupted or, should I say, polluted by a periodic wa wa wa or flange flange flange.

It has always been my feeling that voltage control launched the composer
turn to page 47

Pollard Syndrum

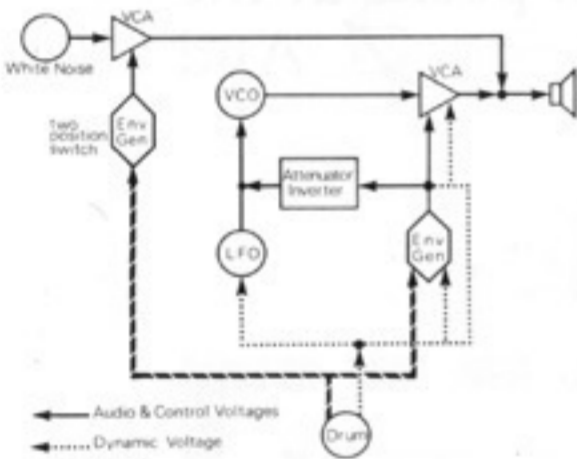

Figure One.

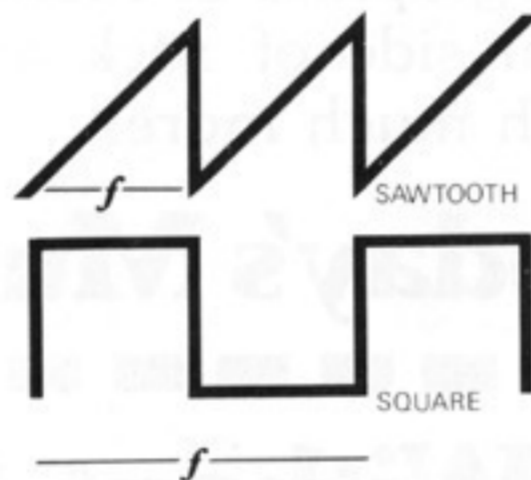

Figure Two.

The trend in electronic music seems to be the interfacing of external devices to the synthesizer. We now have guitar synthesizers, microprocessor controlled synthesizers, and the percussion synthesizer. The Syndrum is designed primarily for drummers, and must be considered more an electronic drum than a synthesizer-drum interface. The Syndrum has been tested for some time with many top percussionists and it has benefited from that research. Unlike most of the other percussion synthesizers, the Syndrum can easily reproduce many drum sounds quite well, even down to the slap of the drum head. The designers stress that the use of sine waves is important to re-creation of a drum sound, and a few minutes with the device proves the point.

Electronically speaking, there is a synthesizer module for each drum, four of each included on the unit that I tested. Each module contains an oscillator in the audible range plus a low frequency oscillator for modulation. The main oscillator has choices of sine, triangle, and square wave outputs, and the LFO has sawtooth, triangle, and square waves. On the LFO, the sawtooth wave is twice the frequency of the triangle and square waves so that the wave form can be switched without an apparent change in tempo as in figure 2 (again, the drummer's point of view). In addition, there is an

turn to page 49

STEINER-PARKER

THE STEINER-PARKER MICROCON

The Steiner-Parker Microcon is a complete synthesizer (less keyboard) in a single module. It has its own power supply, VCO, LFO, VC filter and envelope generator, thereby combining all of the most needed parts of a synthesizer in one unit. It can be used with synthesizer accessories such as sequencers, electronic valve instruments, guitar slave drivers, pitch followers, or with a keyboard. Multiple units can be combined with a guitar controller to form full polyphonic synthesizers at a fraction of the cost normally expected. Combined with a regular synthesizer, it adds an extra "voice" to your present system. Oscillator stability and tracking are the best that state of the art will allow. Numerous inputs and outputs are available on the front and top of the unit. Other signals available inside can be brought out for special applications, and connected to other equipment in a variety of useful ways.

CONTROLS: VCO-course, fine, three wave-forms • LFO-level, rate, beat, vibrato • VCF-frequency, gain, resonance • EG-attack, decay, sustain, damp • VCA-trigger controlled audio gate • + and - triggers out • VC filter in • calibrated and uncalibrated VC in • signal out (can be paralleled) • trigger in • beat function-causes the VCO to sound like two oscillators beating together • List \$300.00 •

STEINER-PARKER

2734 So. 2700 West, Salt Lake City, UT 84119
(801) 972-1447

TOO ROLLING STONED?



*It's time
you tried*



THE NATIONAL TABLOID THAT'S ALL MUSIC!

- Probing, provocative news and features
- In-depth interviews with the Cream of the Pop
- Professional coverage of Musical Instruments, with GIG's "Road Tests" reviews
- Audio/Hifi: news and honest evaluations of the latest audio equipment
- More record reviews than anybody — rock, jazz, classical, obscure, and more
- The GIG Charts; up to date top of the pops — albums and singles
- Lavish illustration and clear, forthright graphics
- Pictorial peeks at the social side of rock and roll
- And much much more!

If You're Into Today's Music -

You Can't Make It Without A GIG!

YES. I want to read about music in my music magazine. Send me the next 9 issues of GIG for just \$4.99 — a 35% saving on the regular newsstand price. If I'm not satisfied I understand I can cancel at any time—for any reason—and receive a full refund on all unmailed issues.

Name _____

Address _____

City/State/Zip _____

MAIL TO: GIG Magazine, 415 Lexington Avenue, New York, N.Y. 10017

Outside the U.S. add \$1.50 additional postage.

GIG1

Featured in this first installment of what will become a regular **Synapse** column are nutshell descriptions of most of the currently available guitar synthesizers. More extensive evaluations will follow in the form of hands-on, road test-type equipment reviews in future issues.

In the last ten years professional and consumer audio systems have developed tremendously. Recording artists have taken advantage of advanced recording techniques, usually employing electric guitar as a main element in their sound. It was the guitar, of course, that introduced new sounds to listeners' ears. Reverb and vibrato at first, then distortion, culminating in ample doses of the fuzz-box. All of this buzzing and grinding meshed perfectly with the new urgency of rock music.

The blitzy fuzz in "Blues Theme" by Davey Allen and the Arrows (from the biker film epic *Wild Angels*) or "Satisfaction" by the Stones nearly conjured the vision of flesh meeting metal. But while guitarists were allowed a few such simple devices to extend the capability of their relatively primitive instruments, it was still the keyboard player who enjoyed the benefit of real advances in musical instrument design.

By the 1970's a new wave of foot boxes had arrived. Guitarists could now wah-wah, phase, flange, compress, limit, octave-divide, ring-modulate and echo-plex their axes off. By processing the amplified vibration of guitar strings through various effects boxes, the guitarist was able to reveal new sounds to his audience. While guitarists worried about coordinating strings of buzzing, ringing, and swooshing pedals at center stage, smirking keyboard players began stacking strange new instruments above their Rhodes and Hammonds. Meanwhile, audio engineers attempting to systemize the techniques of avant-garde or academic tape composers gave birth to a new sound producing instrument: the synthesizer. Theoretically, any sound could be produced by the combination of a few modules, including oscillators, filters and envelope generators. By designing a keyboard that produced voltages at the press of a key, which in turn told an oscillator at what pitch to vibrate, synthesizers could be bought and played by anyone. Except guitar players, who had to keep both hands and wah-wah busy.

Not wanting to miss out on a chance to develop a sizeable market, several manufacturers have seized the opportunity by introducing guitar synthesizers for the guitarist/latent synthesist.

One of the most recent entries in the guitar synthesizer sweepstakes is the **Roland GR-500 Guitar Synthesizer** (\$2,000 list). The GR-500 electronically divides the pitch of a guitar string to produce a synthesizer-made tone that can be heard inde-

GUITAR SYNTHESIS

pendently of the natural guitar sound. With independent frequency division for all six strings, this system provides a full polyphonic sound and allows full left hand technique including string bending, hammering-on, etc. However, with the Roland system you are limited to the use of their own specially built guitar, the GR-500 Guitar Controller. Also, it should be noted that the technique of frequency division produces a square wave shape with a characteristically "buzzy" sound unless the signal is further processed. Whether square waves are attractive and desirable must be decided by the player.

Ampeg utilizes a different technique in producing synthesized sounds from its **Patch 2000 Guitar Synthesizer** (list \$1,395). The heart of this system is a Hagstrom guitar equipped with frets wired in a manner to produce voltages as strings are depressed against them. Because the left hand position on the finger-



PHOTO BY GREG HEET

Michael Campbell, with Tom Petty and the Heartbreakers, shows his E-Bow style.

board determines the voltage sent to the synthesizer's oscillator, picking with the right hand contributes only to the natural guitar sound. You can slide from one end of the neck to the other and still get a discreet half-tone scale from the synthesizer. Pitch bending is accomplished with a pedal device which runs between the guitar and synthesizer. Most synthesizers are compatible with the Patch 2000 though none are supplied with it.

Earlier this year **Arp Instruments** demonstrated two pre-production prototypes, the polyphonic **Centaur**, and the single voice **Avatar** (list \$2,500). Both operate by the method of pitch to voltage conversion. These units consist of a special pickup compatible with most six string electric guitars and an integrated pitch to voltage converter/synthesizer. Both systems allow full transition of left hand technique to the synthesizer. **Guitar Center L.A.** reports they will have received their first Avatars by November 1.

The first company to successfully build and market guitar synthesizers is **360 Systems**. For nearly three years their pitch to voltage Poly-

phonic **Guitar Synthesizer** (from \$13,000) has been used by artists such as Frank Zappa, John McLaughlin, Lee Ritenour, Leon Russell, and Timo Laine. A guitar built by Rex Bogue serves as controller for this system. Equipped with a special pickup, it sends six pitch signals to the "brains" where translation to voltages occurs. These voltages are then routed to six independent synthesizers, one per string. Although Minimoog and E-Mu synthesizers have been used as part of this system in the past, Oberheim Expander Modules are now packaged to provide the synthesizer voicings.

Since thirteen grand is a bit much for most players, 360 has also made a reasonably priced single voice unit, the **Slavedriver** (\$795.00 list). It consists of a special pickup compatible with most six string electrics that sends pitch information to the Slavedriver interface, where pitch to voltage conversion occurs. The unit will follow melody lines, or, when chords are strummed, give the last note in the chord strummed. The pitch-extracted voltage is then sent to the player's chosen synthesizer.

Another device that produces parallel or changing harmonies for the guitar (or practically any sound source) is **Eventide Clockwork's Harmonizer** (from \$1,500).

Used extensively by Todd Rundgren and Roger Powell in the studio as well as on their recent "Ra" tour, the Harmonizer duplicates the approximate timbre of the original source in parallel harmony at any interval, one octave above or below the source. The Harmonizer includes two channels of independent digital display for doubling and echo effects, and a feedback control with the potential for unlimited special effects. Says Powell, "There are certain processing devices which you would automatically use if you were recording. There's no reason to de-

Flanger / from page 45

into the realm of the sculptor and now Analog/Digital Associates have propelled the outboard flanger into the realm of voltage control.

The A/DA Flanger is a finely crafted voltage controlled (0v to +15v) audio flanger with delay variable from 0.4 msec to 14 msec. Delay is controlled by either the potentiometer labeled Manual, the potentiometer marked Rate, or both when combined by the Width control. Of course, the Rate also controls that nasty periodic LFO. Enhance controls a variable feedback loop which at one extreme will produce subtle amplitude peaks and at the extreme, howling, cascading harmonic glisses. Of special interest is the ability to select amplitude peaking at odd or even harmonic relationships. Although it is only a two position switch, it more than doubles the possibilities of this unit. Threshold controls a variable noise eliminating gate that cleans up the unit's act when a low signal is present at its input. Lastly, the frequency response is from 20 Hz to 15 kHz.

The A/DA Control Pedal A is a voltage producing pedal for use with the Flanger if (this is how I look at it anyway) you haven't got a synthesizer to control it with but won't settle for mere periodic modulation.

The A/DA Flanger is highly recommended, and at \$199.95, if you've got the Flanger, you might also consider purchase of a synthesizer to control it.

—Doug Lynner

prive yourself of that sound while you're on stage."

The **E-Bow** from **Heet Sound Products** (\$125.00 list) represents an interesting departure from sound processors. Held in the guitarist's right hand, it magnetically vibrates the strings, producing a wide range of bowed sounds that can be sustained infinitely. Sometime in the future **Musitronics** will take the wraps off the **Gizmo**. Designed by Lol Creme and Kevin Godley, for-



PHOTO BY BILL MATTHIAS

Timo Laine's polyphonic guitar synthesizer is one of the most sophisticated systems now being used in live performance. Look for details in next issue's Guitar Synthesis

merly with 10cc, it reportedly will also produce a bowed sound but through mechanical means.

Aside from the last two products mentioned, the trend toward synthesizer replacement of traditional effects boxes is apparent. ARP has recently been in London showing Jimmy Page and Peter Townshend the **Avatar** and **Centaur**. Peter Frampton is rumored to be recording with 360 Systems' **Slavedriver**. Lowell George of Little Feat has one too. Guitar synthesis has definitely arrived, as Steve Hillage can testify: "In 1975 I met Todd Rundgren and Roger Powell, whom I rate very highly as synthesists, and with their help I made my second album, *L* in Spring 1976, which included some pitch to voltage guitar and a lot of Eventide Harmonizer. I now consider myself as much a synthesizer player as a guitarist."

—Doug Lynner / Chris August

This column first appeared in the September 1977 issue of **GIG** magazine.

SYNTHESIS

Processing & Controlling

with Danny Sofer

Most synthesizers are used as sound generating devices: you play the keyboard and the synthesizer produces sound. However, a synthesizer does not have to operate this way. You can play your synthesizer with anything (well, *almost* anything) if you've got the proper interface. But you ask, "why would I want to do that?"

Well, if you can play the hell out of a violin but only "Chopsticks" on the piano it becomes apparent that by interfacing the violin to the synthesizer you can dramatically increase your timbral options on the violin and your virtuosity on the synthesizer all at the same time.

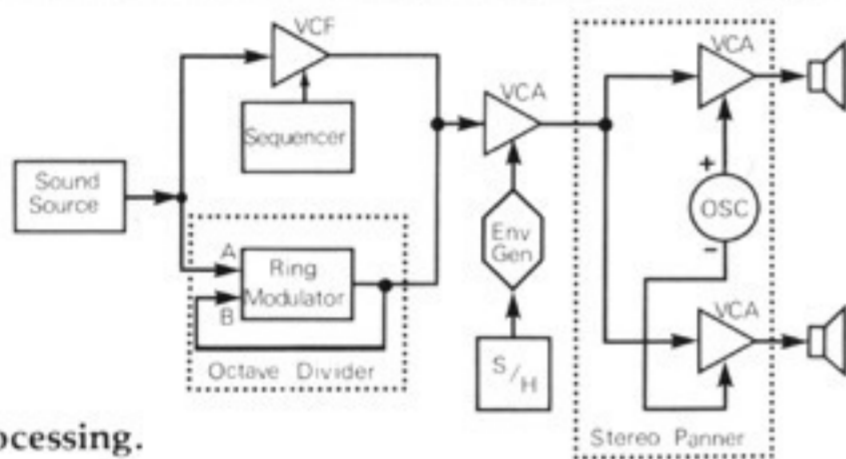
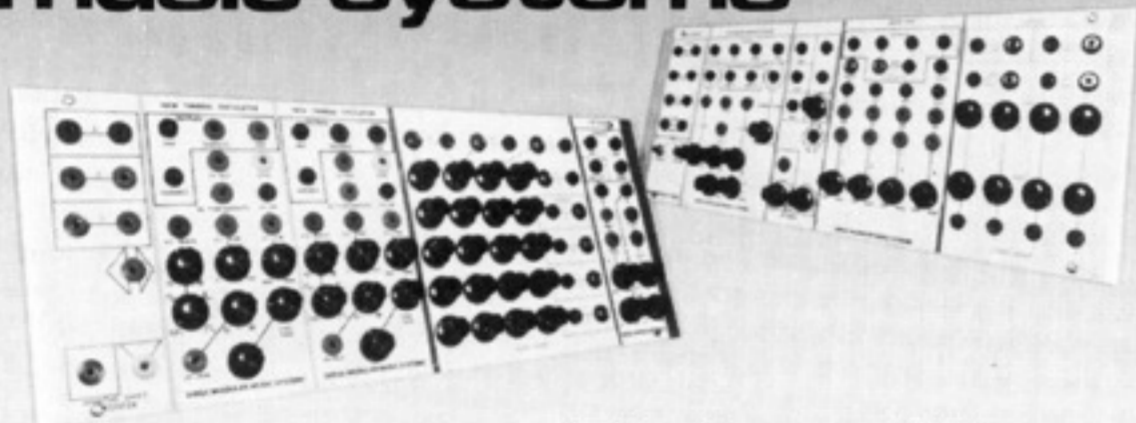

Figure One: Processing.

serge modular music systems



We'd like you to know about Serge Modular. We make what may be the most precise and versatile synthesizer system in use today. The Serge Modular is available either fully assembled or in money saving kit form.

A few specifics about our hardware: We make the trackiest VCO, between 40° to 100° F. Our top of the line oscillators track one another within 1k less than a cycle over the entire range of human pitch perceptible sounds. Our new VCA's and Panners feature over an 80dB S/N, and at least a 60db rejection of control voltage. Many of our modules are patch programmable. This means that they may be patched to perform several functions which in traditional synthesizers would take several (costly) modules.

We wish we could tell you more about **Serge Modular**. Being innovative, and not necessarily falling under run of the mill categories, our modules may cause some consternation. Wherever possible, we'll gladly arrange a live demonstration in your neighborhood. (We find our customers are our best sales people.) If that's not possible, we'll gladly answer your questions by return mail. Meanwhile, you may wish to order a packet of information concerning Serge Modular, consisting of a variety of new product announcements, our catalog & price list, and a short Instruction Manual. All that we ask of you is to send us \$2.00 for the packet, and your name and address to:

**Serge Modular Music Systems
Department Z
1107 1/2 N. Western Avenue
Hollywood, California
90029**

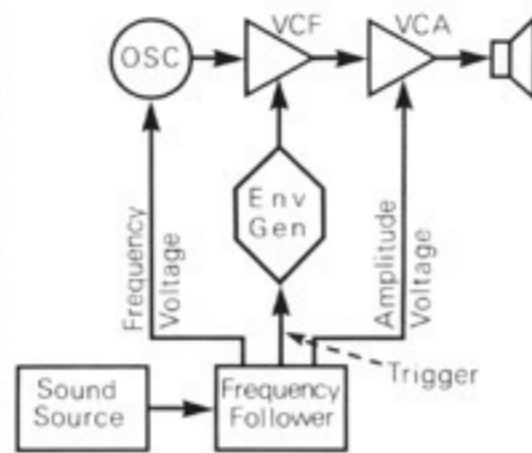

Figure Two: Controlling.

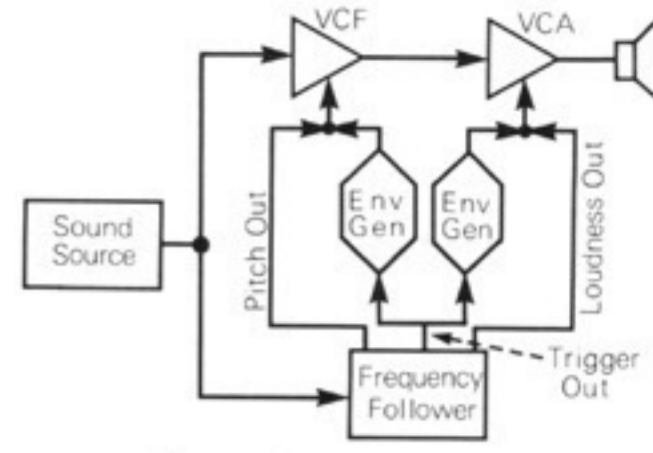

Figure Three: Processing & controlling combined.

In my mind, I divide the alternatives into two groups: Processing, when an outside sound source, such as a piano or guitar is patched into the synthesizer which modifies the timbre of the source without adding any new sound of its own. (fig. 1) The second group, external controllers uses an external device, be it a guitar, drums, microphones, light sensors, or whatever to control the sounds that the synthesizer is putting out, instead of using the keyboard for this (figure 2). If you've got a synthesizer and an electric instrument then you're ready to begin. Of course, an acoustic instrument must be electrified, whether with a microphone or better yet, a pickup such as a Barcus-Berry or Frap, and this goes for instruments that are not normally amplified such as jack hammers and electric toothbrushes. The output from any of these can be plugged directly in to the audio input or mic input of most synthesizer. (If it's not loud enough, use a small mic preamp or phono preamp as the case may be, available at any electronics store.) Usually, the audio input goes into the filter and VCA of the synthesizer which can be controlled by oscillators (LFO's), envelope generators, sequencers or even the keyboard (but the keyboard doesn't control pitch in this case). If you've got a ring modulator, by taking its output back into the second input you can get a square wave an octave lower than what you put in. Also, if you've got two VCA's and stereo outputs you can get a stereo tremolo effect (ala Rhodes) by using a low frequency oscillator to control both VCA's, one positive and negative (see figure 1). All of these effects have one limitation: The synthesizer functions independently of what's processed through it. Now, if we could just get all of these devices to work together . . .

The answer to this problem is to plug your instrument into another box called a frequency follower, pitch follower or pitch to voltage converter. These are actually three devices at once: one part figures out the fundamental frequency (pitch) that you are playing into it and puts out a proportional voltage (usually 1 volt) that can feed the oscillators in the synthesizer so that they play melodically whatever is being played into the pitch follower. The second part is the envelope follower which puts out a voltage proportional to how loud the sound is at any moment, the third section, the trigger sensor, watches for the input sound to go above a certain volume level at which point it puts out a trigger which can be used to fire an envelope generator or advance a sequencer, etc.

Two of these devices are the 360 Systems Pitch Follower (\$595) and the EMS PVC (around \$700). For electric guitars and basses 360 Systems offers the Slavedriver (\$795) that overcomes a lot of potential problems that can result when two or more notes are played at the same time (we are talking monophonic synthesizers here). If you want six synthesized notes out of your guitar simultaneously then get out \$13,000 and get 360's Polyphonic Guitar Synthesizer.*

Whatever your instrument, the synthesizer can now be controlled in all sorts of different ways that simply can't be done with a keyboard. But there is no reason to use only the synthesized sound; by combining control and processing techniques your controlling instrument can also control its own processed sound (figure 3). In this patch the source's frequency controls the filter point, the loudness controls the VCA's output level, and the trigger fires two envelope generators which control filter & VCA envelopes (the frequency & loudness outputs "transpose" these envelopes).

Another way to process sound is by distortion. As any electric guitarist knows, distorting a sound gives it more "balls" and enables a longer sustain than would otherwise be possible. The filter and mic preamp work the best for this. Figure 4 shows a sawtooth wave in its undistorted form (a) and after it has been distorted by overdriving a VCF (b). Notice that the distortion has turned the sawtooth into a squarewave.

I've run through everything rather briefly but by experimentation you should be able to find dozens of new ways to use your synthesizer as something other than a keyboard machine.

*Moog makes an envelope follower which has the frequency control. Also, Serge and EMS synthesizers have a trigger sensor built in.

Using an A/D Converter

with Peter Hillen

When using an analog to digital (A/D) converter it is important to realize its limitations in measuring an unknown analog voltage. These limitations result from inherent errors in the measuring process. The object, of course, is to make the errors as small as possible. To better understand how to use an A/D converter and what some of its sources of error are, let's look at an analogous device: a movie camera. At first they may seem to have nothing in common but they both work on the concept of recording a continuous event by taking a series of samples of it.

A movie camera works by taking a rapid succession of still pictures. Each of these still pictures is a sample of the scene being filmed. It records the position of everything in the scene at that instant of time. Each sample is a valid representation of the scene only for the instant in time it is taken. When the movie film is played back the still pictures are shown in the same sequence in which they were taken and depict the scene as it was. The eye does not detect a series of still pictures, but rather continuous motion, because the playback rate is faster than the eye can respond. Our eye averages the pictures and that gives the effect of continuous motion. An A/D converter works in a similar way. The computer calls for the converter to measure an analog input at some specific sampling time. At each sampling time the converter takes the unknown voltage and converts to a digital word which acts like the "still picture" (see fig. 1). The computer can store each of these measurements for playback later, as in a digital delay line echo, or process them in some way as they are entered.

An important parameter to consider in both of these cases is the sampling rate. It is how often the samples are taken. The events between samples are not accounted for. If the time is short between sample times compared to the action being sampled, then it is possible to guess what happened between samples through an averaging process. If the sampling times are far apart,

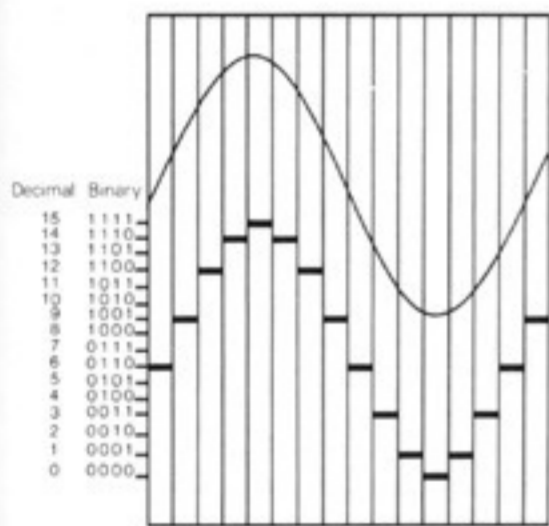

Figure One: Analog sinewave and digital equivalent.

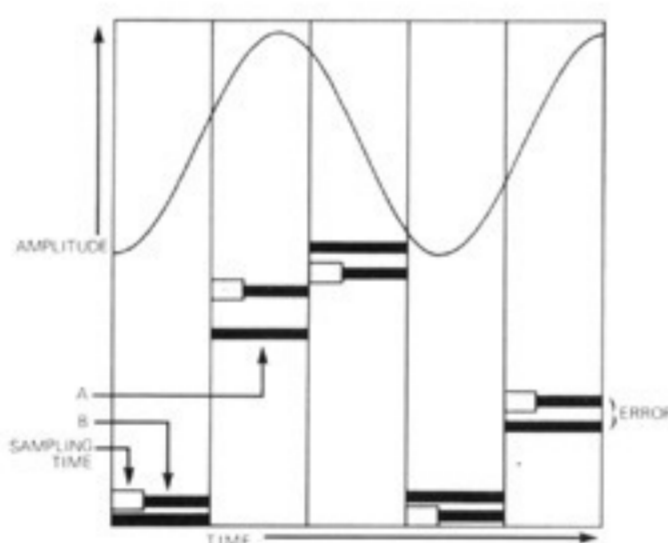

Figure Two: Effect of aperture time on accuracy of sample.

then the samples may not be an accurate representation of the event they sampled. There is a commercial on television where a crown appears on the head of some lucky person who is using a particular product. What has happened is that the camera was stopped, the crown placed on the actor's head and then the camera was started again. It can be thought of as slowing down the sampling rate of the scene and therefore all that transpired on the set was not recorded because some of it happened between samples. Therefore for an accurate conversion the sampling rate should be faster than the fastest event being sampled. Fig. 1 shows a sine wave which was sampled 16 times. The digital reproduction is not very good. Doubling the sample rate to 32 would improve it considerably. However, if only the frequency of the waveform is to be preserved and not the waveshape, then it is necessary to only sample at twice the highest frequency being converted.

In an electronic music system there are two classes of voltages to be

sampled; first are the DC control voltages such as from a keyboard or ribbon controller. These change at relatively slow rates and sampling at a 30 Hz rate is sufficient. The second are audio frequencies: they can go to 20,000 Hz. The sampling rate to preserve the frequency must be 40,000 Hz. Why not just sample as fast as possible? The answer is not electronic but rather economic. Faster speed requires more film in the case of a movie camera or more memory in the case of a computer both of which are expensive.

To help complete the analogy of an A/D converter with a movie camera let us briefly discuss resolution. There is a discussion of resolution in the first part of this article on A/D converters which appeared last issue. Resolution is how close the digital word can come to the analog voltage being measured. It has to do with the number of bits (places) in the digital word. The resolution can be equated to focus in a movie camera. For example, an out-of-focus movie camera is trained on this page and from the pictures that are taken of it we want to see exactly where some of the lines are. The best we could do is determine that the lines were somewhere in a band of fuzziness. We would be tempted to say that the real line is exactly in the middle but because of angle and optical error this is not possible. This fuzzy area corresponds to the space between two consecutive numbers on the A/D converter output that the analog voltage may fall between. For example, if the converter had two place resolution the output would round off an analog voltage of 4.963 volts to 4.96. It could not resolve the .003 volts.

The final error to consider is aperture error. This error is related to how fast the sample of the event can be taken. In a movie camera if the film is slow, meaning that the shutter must be open for a long time to get enough reflected light to expose the film, there is a chance that some images will be blurred because they moved during the exposure time. The remedy is to use faster film which requires shorter exposure time. Electronically an A/D converter takes a finite amount of time to convert the analog voltage to a digital word. In the last issue the time required was shown to be greatly reduced by the use of a successive approximation register. During the conversion time the wave being converted may change causing an error to result. Figure 2 shows a wave being sampled at the same sample rate but with a different sampling or aperture time. "A" is the ideal sampling which takes zero time. "B" takes a finite sampling time. Note that the error of "B" compared to "A" is not the same from sample to sample. The solution to the aperture error problem is to use a smaller aperture time. This could be done by making a faster A/D converter. However, A/D converters get quite expensive as they get faster and in between conversion times they would just sit idle. The solution is to put something in front of the A/D converter which can *sample* the unknown waveform with a very fast aperture time and *hold* at that value until the A/D converter can convert it. The speed and cost of the A/D converter is greatly reduced because now the limit on conversion time is the sample rate, not the aperture time. There can be as much as a 1000 to 1 difference in the two requirements. You may have noticed from italicized words above that this function is performed by a Sample and Hold already familiar in electronic music. It does as its name implies: samples an unknown voltage and holds it for further processing. It is considerably less expensive than a faster A/D converter.

Next time we will explore how a Sample and Hold works and some of its uses.

Syndrum/ from page 45

envelope generator (instant on, variable decay) and VCA, as well as a snare drum circuit within a two position switch that apparently controls the decay of the white noise (short being approximately 50 ms, and long being approximately 250 ms). The envelope generator can be used to control the frequency of the main oscillator, (a sweep up or down) a nice effect used to simulate tablas, loose drum heads or generate further-out sounds.

There is a footpedal to control the frequencies of the main oscillator in each module simultaneously. Also a "kill" switch to cut short a long decaying sound. There are individual high impedance outputs for the modules as well as mixed high & low impedance outputs.

The Syndrum is pressure sensitive, however the dynamic range is somewhat limited and applied only to the LFO envelope generator and VCA, so that while its effect can be detected, it is rather subtle.

The main thing that they've left out is patching; one can't bring drum voltages outside or take other voltages into the Syndrum. There is no way to control, say the main oscillator with the dynamic voltage from the drum alone. Or no way to cause several events to occur simultaneously upon one hit on the drum. Oh well. If you're into getting drum sounds and/or replacing the tom toms on your drum set, then go for the Syndrum. But if you're interested in manipulating your synthesizer with drum sticks the best bet is still the old Moog/Ludwig percussion controller. Perhaps four of them, each with its own Oberheim Expander Module. The Syndrum is made by Pollard Industries, Inc., 9014 Lindeblade Street, Culver City, California 90230.

—Danny Sofer

LISTINGS

In order to provide a comprehensive service to the reader, we have enlarged the scope of our Listings section to include these headings: Sound Recording, Sound Products & Accessories, in addition to Synthesizer Manufacturers, Consultants and Schools. Synapse invites you to use the Listings as a resource to support your activities and asks that you forward the name and address of any company that you feel we have overlooked.

Synthesizer Manufacturers

Advanced Tools for the Arts, P.O. Box 825, Tempe, Ariz. 85281
Analog/Digital Associates, 2316 Fourth St., Berkeley, Cal. 94710
Aries Music Inc., P.O. Box 3065, Salem, Mass. 01970
ARP Instruments Inc., 45 Hartwell Ave., Lexington, Mass. 02173
Audio Arts, Inc., 5615 Melrose Ave., Hollywood, Cal. 90038
Blacet Music Research, 4019 Chico Ave., Santa Rosa, Cal. 95401
Buchla, Box 5051, Berkeley, Calif. 94705
CFR Associates*, Box F, Newton, N.H. 03858
Computone Inc./Lyricon, P.O. Box 433, Norwell, Mass. 02061
Concert Company**, 3318 Platt Avenue, Lynnwood, Calif. 90262
D.B.L. Electronics, 502 Sherman, Canton, Mass. 02021
Dennis (Electronic Music Components) 2130 Metcalf, Honolulu, Hawaii 96822
Electrax, P.O. Box 149, Tarzana, California 91356
Electron Farm/Harvest Gregory Kramer, 135 W. Broadway, New York, N.Y. 10013
Electronic Music Laboratories, P.O. Box H, Vernon, Conn. 06066
Electronic Music Studios, The Priory, Great Milton, Oxford, England
E-mu Systems, 3046 Scott Blvd., Santa Clara, Calif. 95050
Farfisa, 1330 Mark St., Elk Grove Village, Ill. 60007
Galaxy Systems, P.O. Box 2475, Woodland Hills, Cal., 91364
Gentle Electric, 140 Oxford Way, Santa Cruz, Cal. 95060
Heuristics, Inc., 900 N. San Antonio Rd., Los Altos, Cal., 94022
Inner Space Electronics, Box 308, Berkeley, Cal., 94701*
Ionic Industries, 128 James St., Morristown, NJ 07960
Korg/Unicord, 75 Frost Street, Westbury, N.Y. 11590
Logistics, Box 9970, Marina Del Rey, Cal. 90291
MM Electronics, French's Mill, French's Rd., Cambridge, England CB4 3NP
Media Mix, 4060 Stanford, Dallas, Texas 75225
Moog/Norlin, 7373 North Cicero Ave., Lincolnwood, Ill. 60466, Customer Service: 2500 Walden Ave., Buffalo, N.Y. 14225
Musicomputer, 15, 112 W. Sierra Hwy., Canyon Country, California 91351
Music Technology/Crumar, 105 Fifth Ave., Garden City Park, N.J. 11040
Musitronics Corporation, Sound Lab 10, Rosemont, N.J. 08556
Oberheim Electronics, 1549 Ninth St., Santa Monica, Calif. 90401
Octave Electronics Inc., 35-73 Steinway St., Long Island City, N.Y. 11103
Octron, 1346 Bayport Avenue, San Carlos, Calif. 94070
Omniphon, Box 166, Churchill Rd., Mason, N.H. 03048
Oznie Process Electronics, Box 7, Centerville, Penn. 16404

PAIA*, Box 14359 Oklahoma City, Okla. 73114
Pollard Industries, Inc., 9014 Lindblade St., Culver City, Cal. 90230
Polyfusion Inc., 160 Sugg Road, Buffalo, N.Y. 14225
Rocky Mount Instruments, Inc., Macungie, Penn. 18062
Rolandcorp U.S., 2401 Saybrook, L.A., Cal. 90040
Scalatron/Motorola, 2130 N. Palmer Dr., Schaumburg, Ill. 60196
Sequential Circuits, 11726 Aster Ave., Sunnyvale, Cal. 94086
Serge Modular Music, 1107 1/2 N. Western Ave., Hollywood, Calif. 90029
Software Technology Corp., P.O. Box 5260, San Mateo, Cal. 94402
Solid State Music, 2102A Walsh Ave., Santa Clara, Cal. 95050**
Star Instruments Inc., Box 71, Stafford Springs, Conn. 06076
Steiner-Parker, 2258 South, 2700 West, Salt Lake City, Utah 84119
Stramp, 3-2000 Hamburg 53, Bornheide 19, Germany
Strider Systems, P.O. Box 2934, Norman, Okla. 73070
Syn-Cordian, 32-73 Steinway St., Long Island City, N.Y. 11103
Syn-Key, 114 W. Hintz Road, Wheeling, Ill. 60090
THINC-Technical Hardware Inc., P.O. Box 3609, Fullerton, Calif. 92634

DS Music, 811 Franklin St., Santa Monica, Calif. 90403, (213) 463-8772
EMSA (Electronic Music Studios of America, Inc.), 269 Locust St., Northampton, Mass. 01060, (413) 586-3777
Entropy West Electronics, Eric Valinsky, 1242 Harvard St., Santa Monica, Calif. 90404, (213) 828-0389
Electronic Music Studio, Dwight D. Gatwood, Director, University of Tenn., Martin, Tenn. 38238, (901) 584-7402, 587-2281
Exploratory Electronic Music, Steven C. Bilow, 16685 Calneva Drive, Encino, California 91436, (213) 789-6885
Michael Gilbert, 88 Beacon Street, No. 14, Somerville, Mass. 02143
Laine Research & Development, P.O. Box 3219, Fullerton, Cal. 92634 (714) 871-1923, Canada: (416) 226-0041
Lectron Music Lab, Box 1594, Hollywood, Calif. 90028
Sound Arts, 2825 Hyans St., Los Angeles, Calif. 90026 (213) 487-5148
Stan Levine, 13508 Debell St., Pacoima, Calif. 91331, (213) 899-7223
Paradox EMS, Inc., 116 West Broadway, Vancouver, B.C., Canada V5Y 1P3
Patchwork Sound, Jack Howe, 14759 Hesby St., Sherman Oaks, Calif. 91403
People's Computer Company, P.O. Box 310, Menlo Park, Calif. 94025
Pi Corporation, 1741 East 24th St., Cleveland, Ohio 44114, (216) 781-2207
Ron Rivera, 48 Brighton Avenue, No. 11, Allston, Mass. 02134

Sound Products & Accessories

Alembic, P.O. Box 759, Sebastopol, Calif. 95472 (707) 823-8579
Barcus-Berry, 15461 Springdale St., Huntington Beach, Cal. 92649
Carvin Music and Sound, 1155 Industrial Ave., Escondido, Cal. 92025
E Bow/Heet Sound Products, 611 Ducommun St., Los Angeles, Calif. 90012 (213) 687-9946
Electo-Harmonix, 27 West 23rd St., N.Y., N.Y. 10010
Electro-Voice, 674 Cecil St., Buchanan, Mich. 49107
Eventide Clockworks, Inc., 265 West 54th St., New York, N.Y. 10019 (213) 581-9290
FRAP, Box 40097, San Francisco, Calif. 94140 (415) 824-2223
FROGG (Design Engineering Labs Inc.), 4121 Redwood Ave., Los Angeles, Calif. 90066 (213) 823-8220
Hammond, 4200 Diversey, Chicago, Ill. 60639
Heil Sound Systems, Heil Industrial Blvd., Marissa, Ill. 62257
Infitheatre Inc., 4990 Mass Ave., Indianapolis, Ind. 46218
J.D. Electronics, Inc., P.O. Box 2205, Berkeley, Cal. 94702
Marshall Electronic, Box 177, Joppa, MD. 21085
Mellotron/Sound Sales Inc., Sherman, Conn. 06784
Morley Electronics, 2301 West Victory Blvd., Burbank, Calif. 91506 (213) 843-7122
Pro Sound, 13717 S. Normandie, Gardena, Cal.
Rothchild Musical Instruments (distributor Furman and Alembic products), 65 McCoppin St., San Francisco, Calif. 94103 (415) 626-2260
The Ken Schaffer Group, 10 East 49th St., New York, New York 10017
Sennheiser Electronic Corp., 10 West 37 St., New York, N.Y. 10018
TAPCO, 405 Howell Way, Edmonds, Wash. 98020 (206) 775-4411
Wasatch Music Systems, P.O. Box 9175, Salt Lake City, Utah 84109

Sound Recording

Ampex, 401 Broadway, Redwood City, Calif. 94063 (415) 367-4544
dbx Incorporated, 296 Newton St., Waltham, Mass. 02154 (617) 899-8090
Dokorder, 5430 Rosecrans Ave., Lawndale, Calif. 90260
Dolby Laboratories Inc., 731 Sansome St., San Francisco, Calif. 94111 (415) 392-0300
Furman Sound, 616 Canal Street, Suite 25, San Rafael, California 94901 (415) 456-6766
Magnetic Reference Laboratory Inc., 229 Polaris Avenue, Suite 4, Mountain View, Calif. 94043 (415) 965-8187
Maxell Corporation of America, 130 West Commercial Ave., Moonachie, New Jersey 07074
Orban/Parasound, 680 Beach St., San Francisco, Calif. 94109 (415) 673-4544
Otari Corporation, 981 Industrial Road, San Carlos, California 94070 (415) 593-1648
Scientific Audio Electronics Inc., P.O. Box 60271, Terminal Annex, Los Angeles, Calif. 90060
Scotch/3M Magnetic Audio/Video Products Division, 3M Center, Saint Paul, Minn. 55101
Shure Brothers Inc., 222 Hartrey Avenue, Evanston, Ill. 60204
Scully Recording Instruments, 475 Ellis St., Mountain View, Calif. 94943
TDK Electronics Corporation, 755 Eastgate Blvd., Garden City, N.Y. 11530
TEAC Corporation of America, 7733 Telegraph Road, Montebello, Calif. 90640
Telex Communications Inc., 9600 Aldrich Avenue South, Minneapolis, Minn. 55420

What's Happening / Sweden from page 5

on the best of terms with the EMS people had recommended EMS's closing and that in its place decentralized synthesizer studios should be built at all the music colleges. Though the government has not as yet come to a decision Appelton didn't feel like waiting around. He returned to the States in December.

"Other than EMS we have a small studio at The Royal Academy with a tired old Buchla and Ralph Lundsten's Andromedia. The latter is a chapter in itself. About the time they first built EMS, Lundsten, who up till then was doing tape constructions, met a Finlander by the name of Erkki Kurennieni who offered to materialize some of Lundsten's wishful thinking. And if the dates of construction which I received are at all correct Kurennieni must be the biggest fish that ever got away from the hooks of USA's conglomerate instrument manu- turn to page 52

VAKO Synthesizers Inc., 4651 62nd Avenue North, Saint Petersburg, Florida 33565
Wavemakers, P.O. Box 27, Edmonds, Wash. 98020
Yamaha International, Box 6600, Buena Park, Calif. 90620
360 Systems (213) 384-8447. 2825 Hyans Street, Los Angeles, Calif. 90026

Note: * manufacturer makes kits only
** manufacturer makes both kits and finished product

Consultants

Audio Designs, 3422 Brookfield Ln., Decatur, Georgia 30032 (404) 284-8651
Michael J. Boddicker, (213) 985-0010
Boston Experimental Electronic Music Projects, Robert Ceely, 33 Elm St., Brookline, Mass. 02146, (617) 731-3785
Clean Music Systems, Vince Ciamarra, 194 Henderson, Kenmore, N.Y. 14217 (716) 874-1847
Different Fur Music, John Vieira, 3470 19th St., San Francisco, Calif. 94110, (415) 863-WAVE
Disco Tech Musical Electronics, Prospect Mall, 2239 North Prospect, Milwaukee, Wisconsin 53202, (414) 271-9291
Dorje Sound, Chet Wood, P.O. Box 2232, Berkeley, Calif. 94702

Schools

Boston School of Electronic Music, 127 Kilsyth Rd., Brighton, Mass. 02135 (617) 734-4500 / 4501
Con Tempo Music Guild, 13273 Ventura Blvd., Studio City, California 91604 (213) 784-8271
James D. Craig Music, 511 Cedar St., Allentown, Penn. 18102 (215) 437-4743
Dick Grove Music Workshops, 12754 Ventura Blvd., Ste. 2, Studio City, Calif. 91604
Los Angeles Center for Electronic Music, 8615 Santa Monica Blvd., Los Angeles, Calif. 90069 (213) 652-7655, 463-8772
Sherwood Oaks Experimental College, 6353 Hollywood Blvd., Hollywood, Calif. 90028 (213) 462-0669

Classified Ads

20 words or less \$2.00

40 words or less \$5.00

60 words or less \$15.00

Enclose payment with ad and send to:

Synapse/Classified Ads

2829 Hyans Street

Los Angeles, California, 90026

Moog modules, used, 903A, 907, 911, 912, 961, 984. **Polyfusion** dual S+H. **Countryman** piano pickup. Call for negotiable prices. 216-781-2207. David 12-7 pm.

Buchla synthesizer for sale. Includes: 12 place programmable pulse generator, 16 place programmable sequencer, 10 oscillators with VC frequency modulation, 22 VCA's with low-pass option, 9 envelope generators, 4 envelope detectors, 3 6 channel mixers, 3 ring modulators, Hipass, Bandpass and Lowpass filter, 10 channel comb filter, 4 channel comb filter, Quad random voltage and white noise generator, Quad sample-and-hold module, 3 touch sensitive keyboards, Decay and Pitch boards, Power Supplies, 1 Dual Processor. Contact: Mark Sprague (415) 626-9273 or 822-9241. In good condition and built into cabinets.

Brand new with complete factory warranty. **Steiner-Parker Synthacon II**. 2 voice keyboard, 3 VCO's, sample & hold, 3 band VCF, 2 envelope generators, trigger generator, noise generator, VCA, pitch bend, portamento, octave select: \$900.00. (213) 383-7933.

For Sale: **Sequential Circuits Programmer** \$900. **Oberheim Digital Sequencer** \$750. Stephen Rodgers, 121 North Main, Black River, N.Y. 13612.

Sequencer!! The best in the world. One of a kind. Plays any 3-minute song, repeats 16 different 10 to 40 note sequences 256 times in any order. Each note can turn one of 7 switches on or off (VCF's etc.) Can be programmed by a normal person without any keyboard experience at all. Has own keyboard and retains information for a year on batteries. Worth more than 3 Oberheims. \$1799. Sam, (408) 736-4708.

ARP Sequencer, Lists at \$900, only \$400. **ARP Little brother**, Extra 4-note Voltage Controlled Oscillator for any synthesizer lists \$495 only \$250. Sam (408) 736-4708.

For Sale: **Oberheim DS-2a Digital Sequencer**. 144 note capability, mint condition. Must sell \$775 or best offer. Leave name and number at: (213) 385-6681 Unit is in Los Angeles.

For sale: **Moog 35**. \$5,000 or best offer. Also included: fixed filter bank, sample and hold unit and Anvil road case. Not a scratch, all in excellent condition. Call or write: (617) 277-7684 R. Bennett, 94 Francis St., Waltham, Mass. 02154.

Release yourself from the constraints of the keyboard. Play with expression heretofore known only to the violinist, guitarist, and hornist . . . Get yourself a **Joystick** kit from Mediamix. Also used **EML 500** available. Mediamix 4060 Stanford, Dallas, TX. 75225. 214-368-6846.

Synthesists! Overstocked synthesizer dealer needs to make room for new shipment arriving in Sept. Try and beat these prices on the following items.

Oberheim: Digital Sequencer DS2A \$770.00, **Expander Modules** \$420.00, **DS2-Moog Interface** \$525.00, **Four Voice with Mini Sequencer** \$2895.00, **Two Voice** \$1495.00.

Polyfusion: modular systems 30% off, **ASI Analog Seq.** \$350.00, **Steiner-Parker EVI** \$280.00, **Multiphonic Keyboard** \$450.00, **Roland Space Echo** \$350.00, **Nakamichi 500** cassette deck \$350.00, **Teac A3340S** \$800.00. All items include original factory warranty. Additional discounts for Canadians (we're near Buffalo). CLEAN MUSIC SYSTEMS, 110 S.E. Seventh St., Hallendale, Florida, 33009. (305)929-5033

Phillip J. Petillo, **Master Luthier**. Hand-made guitars, repairs, acoustic guitar pickups and unique accessories. Write for brochure: 1206 Herbert Ave., Ocean, N.J. 07712.

Manufacturers— Send me your gadgets! Get testing, feedback from experimental composer - performer. Paul Griffin, 510 Madison Avenue, Albany, NY 12208.

Scanning to form omnipotent electronic synthesizer symphony. Must have control over synthesizers and all other keyboard symmetry. Must be into sounds of Tangerine Dream, Klaus Schulze, Pink Floyd and in that music direction. I have control over a studio and some of its contents, like a modified Oberheim Polyphonic Synthesizer, PAIA 2720 R synths, Sequential Circuits 800 Digital Sequencer, and some sound enhancement like a 3340s Teac open reel, PBX, Altec Lansing #9's, Accuphase E-202 amp., and about 10 bits more. Let's all make musik. Seek and find yourself (212) 848-1773 Tom Gadomski 164-24 98th St. Howard Beach. New York City, New York.

Listen...



WET

The Magazine of
Gourmet Bathing

\$6 to Wet
Box 1017
Venice, California 90291

What's Happening

from page 6
late night TV in L.A. and shows itself not to be for the professional, possibly for amateurs and quite likely the source of frustration if it is used in a professional situation (judging from the TV commercial) as the buzzy tone and the playing technique are not compatible with ears and hands of most contemporary synthesists. At the price of \$260 it does however open the possibility of a synthesizer in every car, especially when you consider the 350S is battery operated and features a light sensitive controller; just prop it up on the dash and let the oncoming traffic play some traveling music for you. Wise up, Cal Worthington, it's more fun than an umbrella hat, motorized pogo stick, or 10,000 Blue Chip Stamps.

... A new acoustic instrument transducer, the B-B Jr., has been introduced by Barcus-Berry Sales Corp. Without a pre-amplifier (promo states it will drive amplifiers without one) the B-B Jr. lists for \$29.50 and that should make for some cost effective instrument processing.

... A low cost Impedance Tester has been released by Pro Sound. The device, useful when setting up a sound reproduction system, lists for \$36.

... Cordless. How many times have you read that word in the music press over the last four months? The general idea is to eliminate cords (guitar and mic. only, at this time) and therefore increase performance ability and decrease the incidents of shocks and bone breaking spills over the countless cords adorning the stages of electronic concerts. But what can this do for those who use synthesizers? As it stands, if you play only one note at a time on gui-

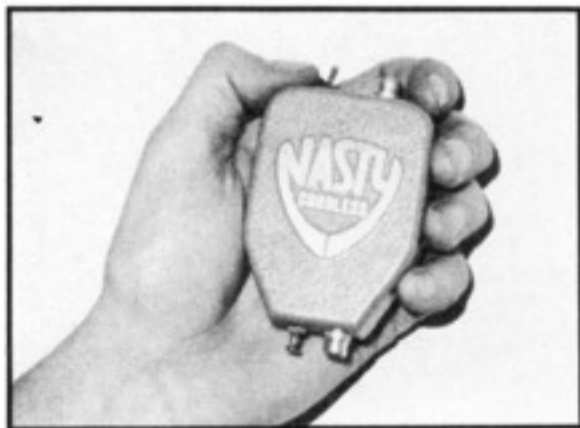

Nasty Cordless from J.D. Electronics.

tar, you may use it to provide information to a pitch to voltage converter or you can send the entire range of the instrument to a synthesizer for processing. With voice or other miked sources the same holds true and in all cases, everything can be off stage except you, your instru-

ment and the transmitter. But what about the traditional synthesizer controller, the keyboard? A synthesizer keyboard does not create "pitches" as we all know. Instead, voltages are produced to control the pitch of an oscillator as with many current controllers like the joystick, sequencer, programmer, or the varied, quasi-instrumental interfaces available. Synapse asked both J.D. Electronics, makers of the Nasty Cordless, and the Ken Schaeffer Group, designers

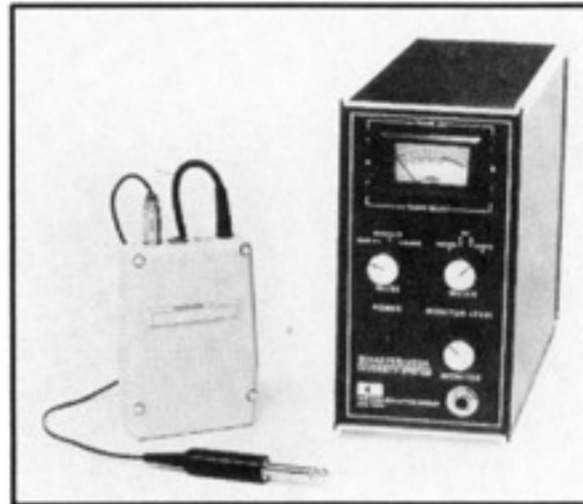

The Diversity System Wireless from Schaeffer-Vega.

of the Schaeffer-Vega Diversity System, if it was possible to transmit control voltages instead of audio frequencies. Both say it is possible but not with the currently available

What's Happening / Sweden from page 50

facturers. I am trying to get a hold of Kurennieni to do an interview. Nowadays he is said to be designing guided missiles for the Germans (naturally).

"Ralph Lundsten doesn't know much about technique himself but he is a very productive composer. Eighteen LPs and a whole lot of ballets, films, etc. etc.

"Let's see what have I forgotten. A collective group of composers, Fylkingen, who often arrange concerts with big names from the continent. And who have their own studio, which I haven't visited in quite some time.

"As to the rock and jazz musicians we are pretty much behind here and the dealers are not making it any easier, or what would you call an eight thousand dollar price tag on a Polymoog?"

units. If the possibility interests you, get in touch with the manufacturers and discuss the options. After all, who needs cordless more than synthesists? J.D. Electronics' Nasty Cordless, is directed to mass market appeal with a price tag of \$450 to \$650 for a complete system. The Schaeffer-Vega Diversity System is directed towards the professional market and costs \$3,300. Why the price discrepancy? We have only seen one unit in use and cannot compare. Once again contact the manufacturers.

... Instrument rentals have to change with the times as do all things. Nevertheless, it may surprise you to find

PHOTOGRAPH BY BILL MATTHIAS



Polyphonic guitar synthesizer programming is now available from Timo Laine.

that in Los Angeles it is possible to rent a 360 Systems Polyphonic Guitar Synthesizer and an experienced programmer for only \$500 a day. The programmer in this case is Timo Laine (Symphonic Slam—A&M SP-4619). Find the number in "Listings" under Laine Research and Development Co.

... Two new modules by Aries Music, Inc. are the AR-328 Stereo Reverb and Output Module and the AR-329 Stereo Phase/Flange Module. The AR-329 is a voltage controlled phase shifter with variable resonance or "Q" and features 1800 degrees of phase shift at the fundamental. The

AR-328 features two independent spring reverbs and channel panning. The AR-329 sells for \$159 kit and \$245 assembled and tested and the AR-328 for \$159 and \$259.

... The 1977 Computer Music Conference took place October 26th through October 30th. The conference, sponsored by the Center for Music Experiment and Related Research of the University of California at San Diego, featured a staggering number of topics, concerts and respected computer music pioneers. Just as a sample, some session titles were, "A Portable Digital Sound Synthesis System," "Understanding the Behavior of the Users of Interac-

tive Computer Music Systems," "Digital Recording Techniques," "Real Time Software for a Digital Synthesizer," "Composer as Surgeon: Performing Phase Transplants," "A Microprocessor-Based Live Performance Instrument," "How Can Composers and Engineers Involve Each Other in the Design of Computer Music Systems." Also of special interest was a series of "Studio Reports," a discussion of various computer music studios around the world.

... Serge Modular Music Systems has recently released a new series of modules with many unusual functions. The New Timbral Oscillator features tracking at 1 volt per octave, a scalable and inversable V.C. input, VC linear FM, VC portamento, VC waveshape from SAW-SINE-PULSE-SQUARE in one continuous range, sync., independent sine, saw triangle wave outputs and fine and gross tuning pots. With no voltage control to the linear F.M., timbral modifications can be made to the output with no pitch change except at extremes and when VC is introduced it can create traditional FM effects (as of course the scalable input can). However, two precision tracking oscillators must be used to take advantage of the linear FM feature as tracking is essential to keeping the timbral/harmonic relationship constant. For this purpose they have also released the Precision Control Oscillator, a simplified version of the NTO. The PCO costs \$100 in kit and \$150 in assembled form and the NTO costs \$160 kit and \$210 assembled. Two new filters are the VCF-VCQ and Variable Slope VCF. The VCF-VCQ includes a one volt per octave input, voltage controlled resonance (Q) and a Percussion Pulse input which enables the filter to be a versatile percussion generator. The Variable Slope VCF features voltage control over the slope of the filter while retaining constant amplitude and a one volt per octave input. Both modules sell for \$100 in kit, \$140 assembled. Also new from SMMS is the Equal Power Series of VC panning and VC crossfading modules. The formats and prices vary greatly.

... With the contemporary interest in other than 12 tone music, the Scalatron and Generalized Keyboard are very timely. The Scalatron is a keyboard instrument capable of programming 24,552 discreet tones to the octave and starts from \$6,200 and up. The Generalized Keyboard, developed by George Secor facilitates the live performance of microtonal music and can store different tunings simultaneously. System prices vary according to specification. Contact Motorola Scalatron for quotes.

... Please refer to the "listings" section for addresses not found above.

33 1/3 % Pure Savings!

That's right. A real deal for all you starving folks anxious to be included among the hallowed rolls of **Synapse** subscribers.

By subscribing now (or renewing your current subscription) you'll save 33 1/3% (\$3.00) over next year's newsstand price—and that's a healthy 20% savings over next year's subscription rate of \$8.00, too!

So don't wait—send \$6.00 for a one year/six issue subscription (or \$7.50 in US funds only for those of you readers outside the USA). Use the handy postage-paid envelope in this issue, or send your name, address, and check to:

**Synapse/2:3, 2829 Hyans Street,
Los Angeles, California, 90026.**

Please note that all subscriptions start with the upcoming issue—not past issues, sorry.

Synapse

We thank our dealers and distributors for helping make **Synapse** a continued success. **Readers:** If your local shop doesn't carry **Synapse** they should. Show them **Synapse** and get them in touch with us. **Retailers:** What are you waiting for? Write or call: **Synapse Retail Sales**, (213) 383-7933, 2829 Hyans Street, Los Angeles, California 90026.

AUSTRALIA

Brookvale
Farrell Keyboards
Claremont
Zenith Music
Fitzroy
Warehouse Sound Company

CANADA

Montreal
Richard's Music Shop
Vancouver
Paradox EMS
Winnipeg
Guitarland

JAPAN

Tokyo
Distributed by
Music Joy/Rittor Publishing
and
ASCII Publishing

CALIFORNIA

Azuza
Music Plus
Berkeley
International News
Rather Ripped Records
Beverly Hills
Pico-Robertson News
El Cajon
Blue Meanie Records
Glendale
Music Plus
Hermosa Beach
Music Plus
Hollywood
Guitar Center
Guitar Villa
Musician's Contact Service
Music Plus
World Book & News
Long Beach
Music Plus
Whittaker Music
Zed of London Records
Los Angeles Area
Distribution by
Bookman and Levity Distributors
Monterey Park
Music Plus
North Hollywood

Music Plus
Oakland
Leo's Music
Ocean Beach
The Black
Orange
Music Plus
Record Trading Center

Pacific Beach
Licorice Pizza
Pasadena
Music Plus
Placentia
Music Plus
San Diego
Guitar Center
Sound West
Tower Records
San Francisco
Guitar Center

San Francisco Area
Distribution by
Serendipity Couriers

San Luis Obispo
Square Deal Records
San Rafael
Bananas at Large
Santa Ana
Music Plus
Santa Barbara Area
Castle Music
Fancy Music
Jensen Music
Morninglory Music
Turning Point Records
Valley Music
Santa Clara
Byte Shop No. 2
Santa Cruz
BookShop Santa Cruz
Santa Monica
Lincoln-Pico News
Papa Bach Paperbacks
Sherman Oaks
Baxter-Northrup Music
Music Plus
Solana Beach
Isness Records
Studio City
Music Plus
Sunnyvale
Recreational Computer Center

Thousand Oaks
Music Plus
Van Nuys
Computer Components
Westminster
Music Plus
West Covina
Hanich Music
West Los Angeles
Rhino Records
Whittier
Music Plus
Whittier Professional Music

COLORADO

Denver
Schaeffer Enterprises
Englewood
Byte Shop
Mountain states distribution by
High Paper/Boulder

CONNECTICUT

Danbury
Danbury Electronic Music

FLORIDA

Hallendale
Clean Music Systems
Lynn Haven
Jan's

ILLINOIS

Chicago Area
Distribution by
Gulliver's Periodicals
Highland Park
Gary Gand Music
Hoffman Estates
Readers World
Marissa
Ye Olde Music Shop

INDIANA

Indianapolis
I.R.C. Music

KENTUCKY

Bowling Green
Fairview Plaza Music Center

LOUISIANA

New Orleans
Allied Music

MARYLAND

Randallstown
Randallstown Music

MASSACHUSETTS

Boston
E.G. Wurlitzer
Pampalone's
Waltham
Computer Mart

MICHIGAN

Ann Arbor
Community News
Canton
Arnoldt-Williams Music
Dearborn
Dearborn Music
Little Professor
Detroit
Bookworld
Ecorse
Booknook
Farmington
Fireside Bookstore
Oakpark
Little Professor
Oxford
Book Place
Pontiac
Front Page Books
Royal Oak
Mickey Shorr
Saginaw
Bay Music
Taylor
Open Book Store
Distribution Throughout
Michigan by
Big Rapids Distributing

MISSISSIPPI

Crenshaw
The Music Men

NEVADA

Las Vegas
The Drum Shop

NEW JERSEY

Paramus
Sam Ash

NEW YORK

Brooklyn
Sam Ash
Hempstead
Sam Ash
Huntington
Sam Ash
Manhattan
Sam Ash
White Plains
Jack Bronen's Music
Sam Ash

Plus newsstand distribution
in Manhattan by
Rag Woman Distributors

OHIO

Cleveland
Mayfield Music
Pi Corporation
Streetsboro
Streetsboro Music

PENNSYLVANIA

Bryn Mawr
Medley Music
Roselle
Roselle Music

TENNESSEE

Memphis
Strings & Things
Nashville
Music Man

VIRGINIA

Norfolk
Ambassador Music

WASHINGTON

Seattle
The Electronic Music Box

WISCONSIN

Madison
Ward-Brodt Music
Distribution Throughout
Wisconsin by
Wind Madison
Milwaukee
Disco-Tech Musical
Electronics



Do it with a Cat

DAVE FREDERICKS: recording artist, composer, keyboard virtuoso and lecturer, is best known as one of the most inventive and versatile synthesist/organists in the world. Throughout his career, Dave's concerts have drawn "standing room only" crowds in England, Continental Europe and Japan. As a result, he earned second place in a recent KEYBOARD WORLD poll as best jazz organist.

Synthesizers were considered unrealistic for real-time performance until Dave began using them in concert - in fact, he is often referred to as one of the few "pioneer musicians" that took the synthesizer out of the lab and onto the stage. His extensive use of synthesis equipment has enabled him to enlighten such prominent figures as Edgar Winter, Pat Moraz, Blackbyrds and Roger Williams on methods of obtaining the most from their synthesis equipment.

Formerly a Vice-President of ARP instruments, Dave is presently with Thomas Organ and is a consultant for Octave on its human engineering and project initiations of electronic music equipment.

If your use to the versatility of a studio synthesizer, which offers things like mixing wave shapes, you'll find it on our CAT. All 7 of our waveshapes can be simultaneously mixed giving you unlimited versatility.

If simplicity and ease of performance is what your looking for we think Rod Argent said it best in his review of the CAT synthesizer in *International Musician and Recording World**, "The VCA module set on the right hand side of the synthesizer as the last link in the chain, is simplicity itself". "A first glance at the CAT sets the scene quite well. The layout is Extremely efficient, visual and easy to follow". The CAT synthesizer was designed to give you the versatility of studio equipment yet it is easy to operate and understand.

From concert performances to local gigs you can probably do it better with a CAT than any other competitively priced synthesizer presently on the market.

The CAT offers you more of what you need: a sub octave on each oscillator, 2 note capability, 4 note sequencer patch plus much, much more.

The Price? Hundreds of dollars less than its closest competitors. So why wait. on your next gig "do it with a CAT".

BULK RATE
U. S. POSTAGE
PAID
No. Hollywood, CA
PERMIT NO. 456

OCTAVE *Electronics Inc.*
An Affiliate of Syn-Cordion Musical Instruments Corp.
32-73 STEINWAY STREET - LONG ISLAND CITY, N. Y. 11103

THIRD CLASS MAIL

*For the complete review of the CAT synthesizer by Rod Argent write: *International Musician and Recording World*, 501 S. Main St., Spring Valley, New York 10977, (914) 356-2570.