



B RAIL MAINTENANCE SOLUTIONS



PERTH
(08) 9459 8600
KALGOORLIE
(08) 9021 8300

ADELAIDE
(08) 8231 1513
NEWMAN
(08) 9175 1164

DARWIN
(08) 8963 5621
MT ISA
(07) 4743 6458

✉ sales@bendtechgroup.com.au
🌐 bendtechgroup.com.au

2-10 Kewdale Road, Welshpool WA 6106



RAIL MAINTENANCE SOLUTIONS INDEX

CDEC PROCESS	///	2
MAJOR PROJECTS	///	3 - 7
PLATFORMS	///	8 - 14
MAINTENANCE	///	15 - 21

WE OFFER A FULL CONSULTING, 3D SCANNING AND ENGINEERING SERVICE

Projects and the associated challenges often require custom solutions, we take pride in our CDEC system. Consultation, Design, Engineering and Construction is our holistic approach to solution development making maintenance on-site safe, efficient and easy.

CDEC PROCESS



CONSULTATION We come to you and visit your site to get a hands-on feel for your project. The aim of our consultation is to listen to and understand your requirements. If the project requires it, our 3D scanning capabilities will streamline measurement and data capture. This approach allows us to develop and discuss with you on-site, possible solutions to your problem, and the benefits we can offer.



DESIGN After the consultation we go back to our design team to begin the development of your custom solution. Our team produce designs in CAD Design complete with all drafting documentation ensuring an advanced manufacturing process. Our process allows and encourages you to be involved in the design stage and collaborate with our highly skilled team.



ENGINEERING Once the design is approved, we begin the development and engineering process. This ensures that the right material is used for your project to guarantee structural and functional integrity. We provide full certification that includes WLL, load ratings, integrity reports as well as certificate plates and identifications. We design and engineer all our solutions to ensure full compliance to ensure full compliance with Australian standards.



CONSTRUCTION Finally, once the project is ready and certified for construction, we manufacture your solution. We test, machine, fabricate and surface treat as well as trial fit your custom project. We only manufacture high quality products that provide long lasting, safe and efficient solutions.



B

B / **BIGGER
THAN
BUSINESS**

MAJOR RAIL PROJECTS

 www.bendtechgroup.com.au

B

MAJOR RAIL PROJECTS

Our team of consultants, draftsman, engineers and fabricators are experienced in developing solutions for an extensive range of problems and applications. Our exposure to such a broad range of industries, legislation and low tolerance specifications has allowed us to develop unrivalled expertise and problem-solving abilities.

BRAKE LINES

We have supplied end-to-end brake line solutions for railway ore cars for over 15 years, we have supplied over 5000 complete kits. These have encompassed the full drawing, design and placement of pipelines. We procured and supplied all of the raw materials including; pipework, high-pressure fittings and valves.

We developed complete easy-weld jigs built to incorporate pipework and all finished manifolds were comprehensively inspected for leaks. The complete brake lines were bent to specification on our CNC benders and constructed for final cleaning and capping, ready for delivery.

“

**EXPERTISE,
UNDERSTANDING
AND WORKMANSHIP
DRIVES OUR SERVICE**

”



ORE CAR REPAIR AND UPGRADE

This ongoing project required and upgrade of 1500 steel wagons, this involved many different components over a 3-year period. These included plate works, structural members, wear pads, pipework, shims and bosses, machined parts and connectors, reverse engineering and replacement of OEM parts.

ACCESS PLATFORMS

We have constructed many certified and compliant access platforms. In particular for rail and locomotive applications, we have designed and engineered platforms for the safe access of roof areas, air conditioning units and rail tooling.

“ COMPLETE LOCOMOTIVE
WORKSHOP SOLUTIONS ”

HANDRAILS



Our design, engineering and manufacture of handrailing for locomotives, wagons and rail workshops have increased safety as years and legislation has passed. All of our handrails are designed for full certification and compliance with Australian Standards.

OTHER PROJECTS

Along with our design and engineering departments, our industry leading fabrication, plate cutting, roll forming, press forming as well as bending and rolling services align us with an end to end solution for many projects.

PROJECTS INCLUDE :

- Doors
- Pipework
- Ancillary components
- Brackets
- Transport frames
- Lighting brackets
- Gates



PLATFORMS

PLATFORMS

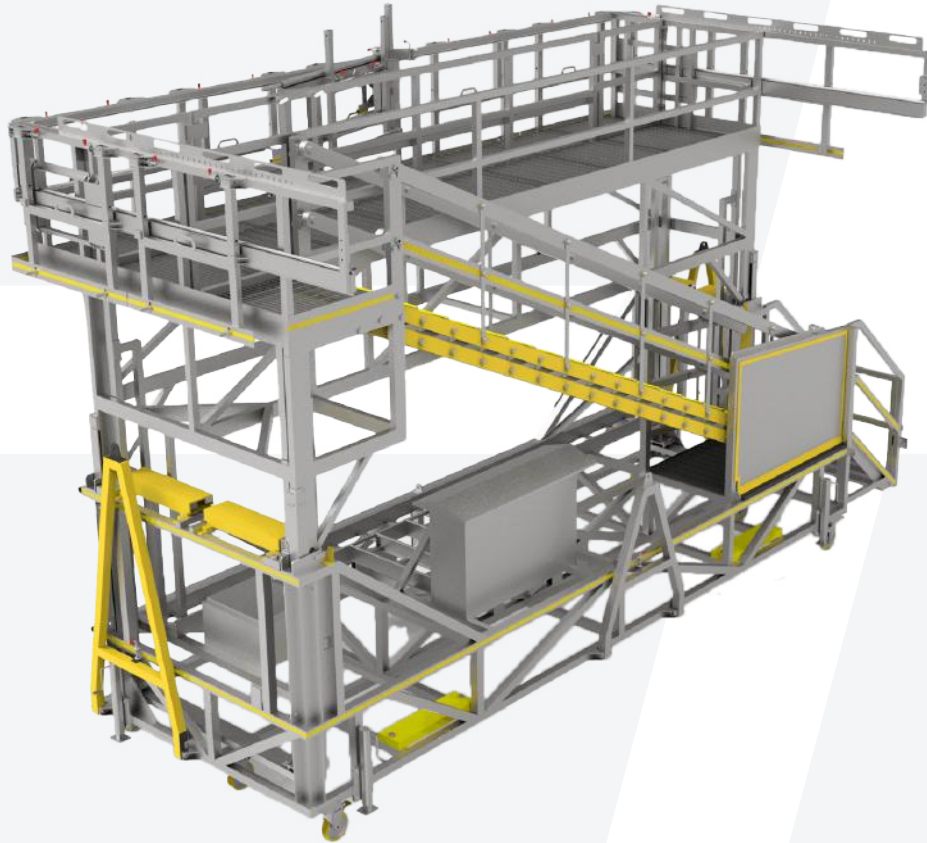

TRACK MACHINE MOBILE ACCESS PLATFORM

Part No. 5501793

Designed and engineered for safe, efficient and easy maintenance.

CONSTRUCTION

- Heavy-duty aluminium
- Extended height handrails
- Sliding handrails on the side extend by 2.2m
- Complete safety when working in hard to reach areas
- Non-slip stairway and work area
- Self-closing door
- Replaces the need for scaffolding or EWP's
- Wheels for ease of manoeuvrability on site
- Tow-point which attaches to a tug, for easy movement
- Comprehensive sensors provided – on all gates and height sensors on the adjustment system.
- Adjustable in height
- Hinged ladder system, which alters angle as the platform adjusts up and down
- This item can be customised to meet your specific needs and is engineered, certified and built to Australian Standards.

PLATFORMS

TRAIN POSITIONER MOTOR ACCESS PLATFORM SET

Part No. 5501051

CONSTRUCTION

- Heavy-duty aluminium
- Complete safety when working in hard to reach areas
- Non-slip stairway and work area
- Self closing gate
- Replaces the need for scaffolding
- Wheels for ease of manoeuvrability on site
- This item can be customised to meet your specific needs and is engineered, certified and built to Australian Standards.



TRAIN POSITIONER CONTINUARY ROLLER ACCESS PLATFORM

Part No. 5414052

CONSTRUCTION

- Heavy-duty aluminium
- Wheels for ease of manoeuvrability on site
- Aluminium scaffold planking
- Non-slip stairway and work area
- Extended height handrails
- Complete safety when working in hard to reach areas
- This item can be customised to meet your specific needs and is engineered, certified and built to Australian Standards.



RAILCAR CLAMP WEAR PAD ACCESS PLATFORM

Part No. 5501033

CONSTRUCTION

- Heavy-duty aluminium
- Wheels for ease of manoeuvrability on site
- Non-slip stairway and work area
- Self-closing gate
- Safety handrails
- This item can be customised to meet your specific needs and is engineered, certified and built to Australian Standards.



PLATFORMS

RAILCAR ACCESS PLATFORM

Part No. 5401530

CONSTRUCTION

- Heavy-duty aluminium
- Removable handrails
- Adjustable height jacks to compensate for ground undulation
- Non-slip stairways and grating
- Modular build can be broken down and easily transported around site or rail yard
- This item can be customised to meet your specific needs and is engineered, certified and built to Australian Standards.



TRAIN LOAD-OUT PLATFORM

Part No. 5502570

CONSTRUCTION

- Heavy-duty aluminium
- Non-slip stairway and work area
- Self closing door
- Fitted with counterweights
- Fitted with heavy-duty castors
- Fitted with jacking stands



CAR DUMPER ACCESS PLATFORM

Part No. 5502481

CONSTRUCTION

- Heavy-duty aluminium
- Non-slip stairway and work area
- Fitted with heavy-duty lockable castors
- Fitted with work bench
- Also suitable for the KOMASTU 8730E



PLATFORMS

TRAIN ACCESS PLATFORM

Part No. 5501361

CONSTRUCTION

- Heavy-duty aluminium
- Non-slip stairway and work area
- Fitted with non-slip step nosings
- Self-closing gates
- Fitted with heavy duty castors
- Fitted with forklift slots
- Certified and compliant with Australian Standards



MODULAR LOCOMOTIVE ACCESS PLATFORM

Part No. 5501336

CONSTRUCTION

- Heavy-duty aluminium
- Modular design
- Removable handrails
- Non-slip stairway and landings
- Self-closing gate



RAIL CAR ACCESS PLATFORM

Part No. 5501877

CONSTRUCTION

- Heavy-duty steel
- Welds to existing plant structure
- Ladder access
- Full assembly bolts together for ease of transport
- Removable Handrails
- Grating completely hot dip galvanised
- Handrails finished in Y14 safety yellow



PLATFORMS

ALUMINIUM RAIL PLATFORMS

Part No. 5501520

CONSTRUCTION

- Heavy-duty aluminium
- Non-slip stairway and work area
- Self-closing gate at the top of the stairs
- Fitted with forklift slots



TENDER CAR DUMPER WHEEL GRIPPER REMOVAL PLATFORM

Part No. 5501143

CONSTRUCTION

- Heavy-duty steel
- Hot dip galvanised
- Bolt-on handrails
- Fitted with lifting lugs
- Fitted with non-slip step nosings

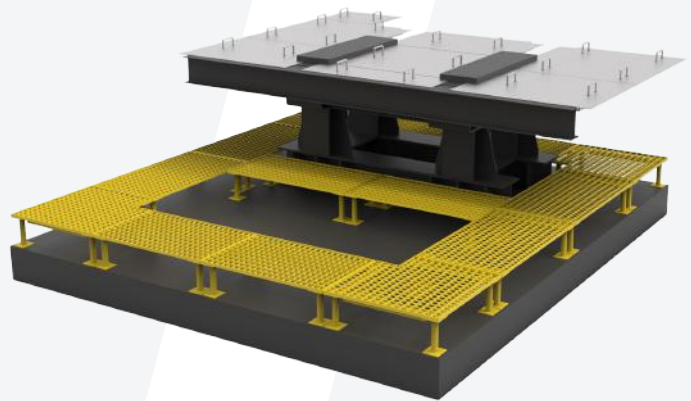

ALUMINIUM RAIL PLATFORMS

Part No. 5501377

CONSTRUCTION

- Heavy-duty steel
- Bolt-on handrails
- Bolt-in step treads
- Fitted with lifting lugs
- Fitted with non-slip step nosings



PLATFORMS

UNDER LOCOMOTIVE WORK STEPS

Part No. 5503775 - 4 Step
Part No. 55037751 - 2 Step

CONSTRUCTION

- Heavy-duty aluminium
- Non-slip step nosing's
- Heavy-duty non-slip grating
- Heavy-duty Blicke castors
- Certified and compliant with Australian Standards



LOCOMOTIVE HANDRAIL EXTENSION

Part No. 5503780

CONSTRUCTION

- Heavy-duty steel
- Certified and compliant with Australian Standard
- Bolts on to existing handrails
- Painted to your requirements
- Can be customised to suit your handrail requirements





3 **BIGGER
THAN
BUSINESS**

MAINTENANCE

 www.bendtechgroup.com.au



MAINTENANCE

**RAIL SECTION
TRANSPORT FRAME**
Part No. 5502094

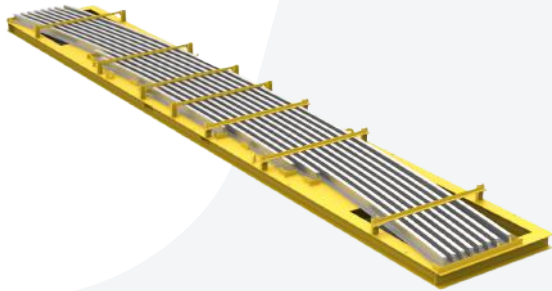

CONSTRUCTION

- Heavy-duty steel
- Fitted with lifting lugs
- Certified and compliant with Australian Standards

WHEEL BLANK SUPPORT TABLE
Part No. 5501898



CONSTRUCTION

- Heavy-duty steel
- Hinged Flip-up section accommodating gas struts for reduced manual handling
- Finished in Y14 Safety Yellow
- Certified and compliant with Australian Standards

RAIL CAR WHEEL GRIPPER
Part No. 5505694



CONSTRUCTION

- Heavy-duty steel
- Attaches to a crane
- Designed to minimise manual handling
- Finished in Y14 safety yellow

WHEEL BLANK LIFTER
Part No. 5501899

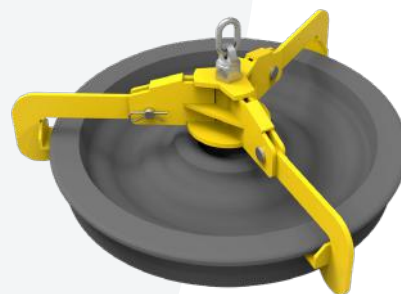

CONSTRUCTION

- Heavy-duty steel
- Designed for various size wheel blanks
- Attach to a crane for easy transport
- Heavy-duty steel construction
- Certified and compliant with Australian Standards

MAINTENANCE

LOCOMOTIVE CAMERA SHIELD

Part No. 5501381

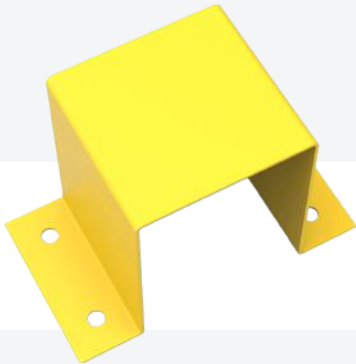

CONSTRUCTION

- Heavy-duty steel
- Blasted, primed and painted to your requirements
- Designed to guard and protect the camera on locomotives

WHEEL BOBBIN

Part No. 55013231 V1

Part No. 55013232 V2

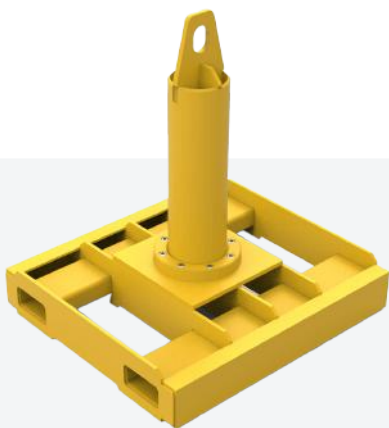

CONSTRUCTION

- Heavy-duty steel
- Transport stand for rail wheels
- Fitted with forklift slots
- Finished in Y14 safety yellow
- Certified and compliant with Australian Standards

LOCOMOTIVE BREATHER VENT LOUVRES

Part No. 5501462



CONSTRUCTION

- Heavy-duty steel

“ **COMPLETE
LOCOMOTIVE
WORKSHOP
SOLUTIONS** ”

MAINTENANCE

EOTD CARRIER

Part No. 5502140

CONSTRUCTION

- Heavy-duty steel
- EOTD removal tool
- Finished in Y14 safety yellow
- Certified and compliant with Australian Standards



KNUCKLE CARRIER TROLLEY

Part No. 5501607

CONSTRUCTION

- Heavy-duty steel
- WLL: 50kg
- Certified and compliant with Australian Standards
- High-performance coated in Y14 yellow

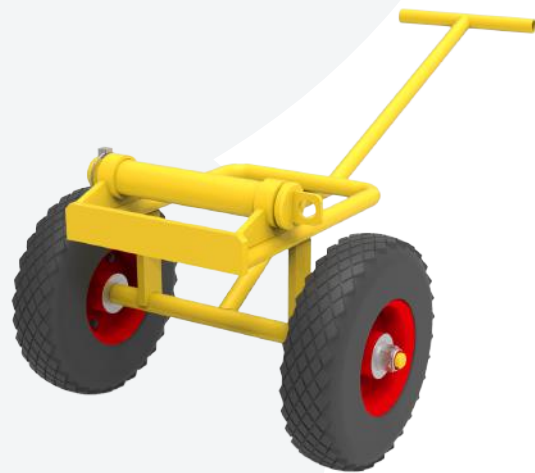

ADJUSTABLE STAND

Part No. 5501626

CONSTRUCTION

- Heavy-duty steel
- WLL: 270 Tonne
- Certified and compliant with Australian Standards
- Adjustable to 5 heights
- Blasted, primed and coated to site requirements
- Can be customised to your requirements



MAINTENANCE

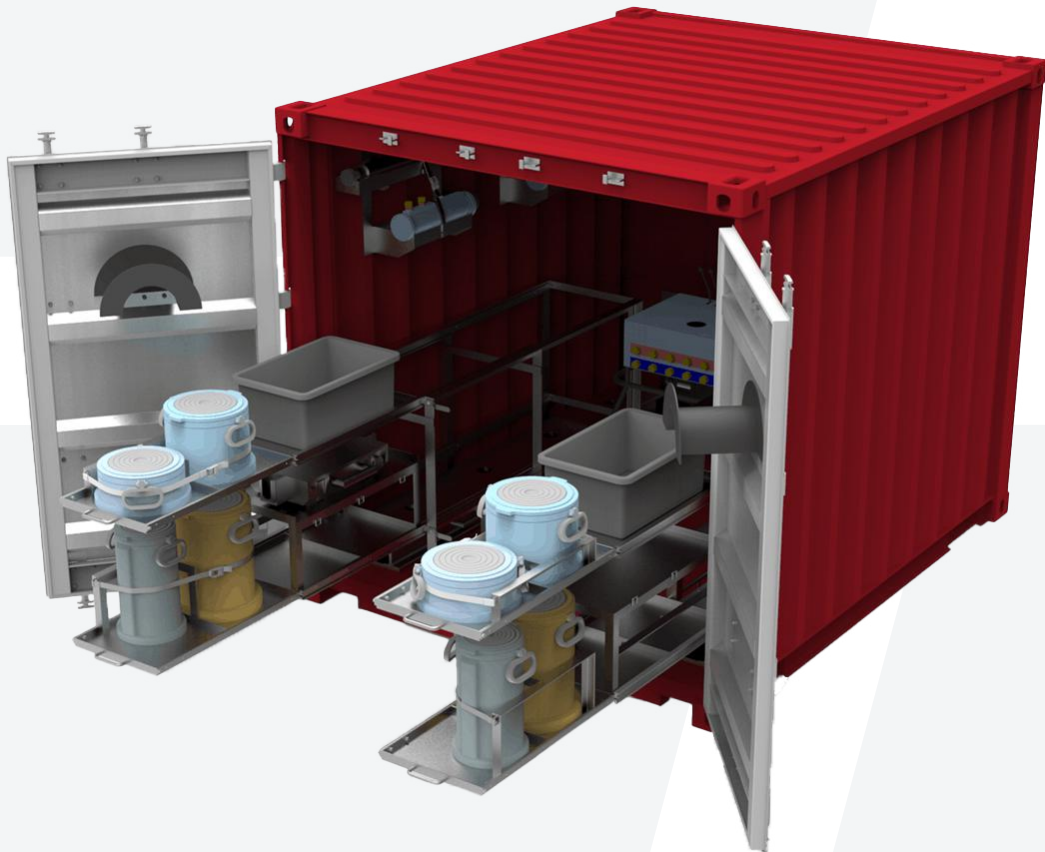

TRAIN DERAIL TOOLING KIT

Part No. 5502157

A comprehensive rail maintenance enablement kit. This unit can be customised to your requirements . Fully contained in a standard 10ft container

CONSTRUCTION

- Heavy-duty aluminium
- Comprehensive kit to be used in the case of a train derail
- Includes slide-out sections for ease of use
- Fully contained inside a compact, standard 10ft container
- Can be customised to suit your requirements
- Fitted with forklift slots
- Certified and compliant with Australian Standards

MAINTENANCE

SLOT STAND FOR RAIL AXLE SETS

Part No. 5503143

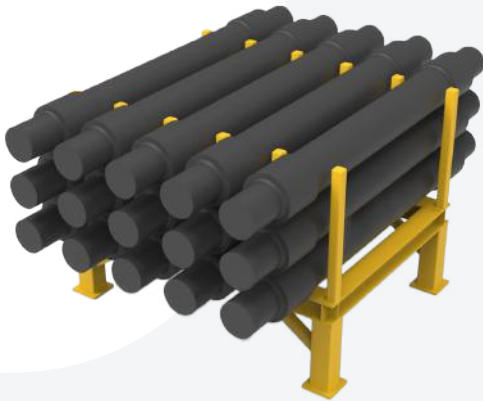

CONSTRUCTION

- Heavy-duty steel
- WLL: 7T
- Holds 15 axles safely
- Finished in Y14 safety yellow
- Certified and compliant with Australian Standards

RAIL AXLE STANDS

Part No. 5503740



CONSTRUCTION

- Heavy-duty steel
- WLL: 2.8T
- Holds 4 axles safely per stand
- Hot dip galvanised
- Fitted with forklift slots
- Certified and compliant with Australian Standards

WHEEL SET SUPPORT STAND

Part No. 5503144



CONSTRUCTION

- Heavy-duty steel
- WLL: 2T
- V-shaped top with rubber lining
- Fitted with handles for mobility
- Certified and compliant with Australian Standards

MAINTENANCE

KNUCKLE CARRIER

Part No. 5502164



CONSTRUCTION

- Light-weight aluminium
- WLL: 45kg
- Eliminates manual handling

SWITCH CLAMP ISOLATION DEVICE

Part No. 5503143

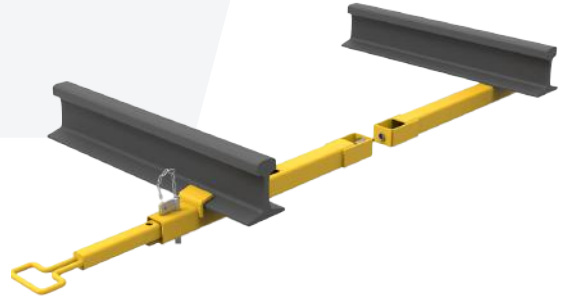

CONSTRUCTION

- Heavy-duty steel
- Tool used to isolate switch clamps
- Can be customised to your requirements
- Certified and compliant with Australian Standards

ALTERNATOR ALIGNMENT JIG

Part No. 5501642

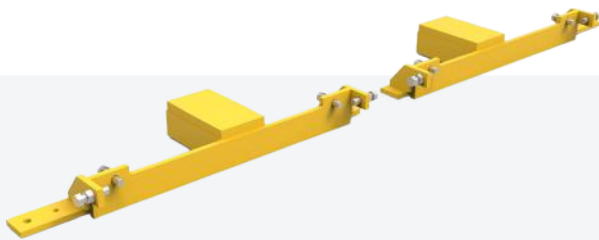

CONSTRUCTION

- Heavy-duty steel
- Alternator alignment tool
- Finished in Y14 safety yellow
- Certified and compliant with Australian Standards

BEARING LIFTING JIG

Part No. 5502141

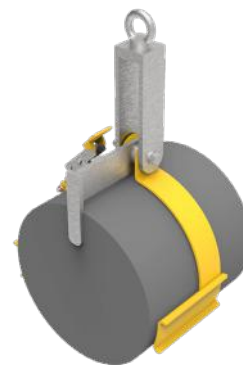

CONSTRUCTION

- Heavy-duty steel
- Lined with rubber for increased grip
- Certified and compliant with Australian Standards

B BIGGER THAN BUSINESS

TAKE NOTE



TAKE NOTE



B BIGGER THAN BUSINESS

TAKE NOTE



TAKE NOTE



B BIGGER THAN BUSINESS

TAKE NOTE



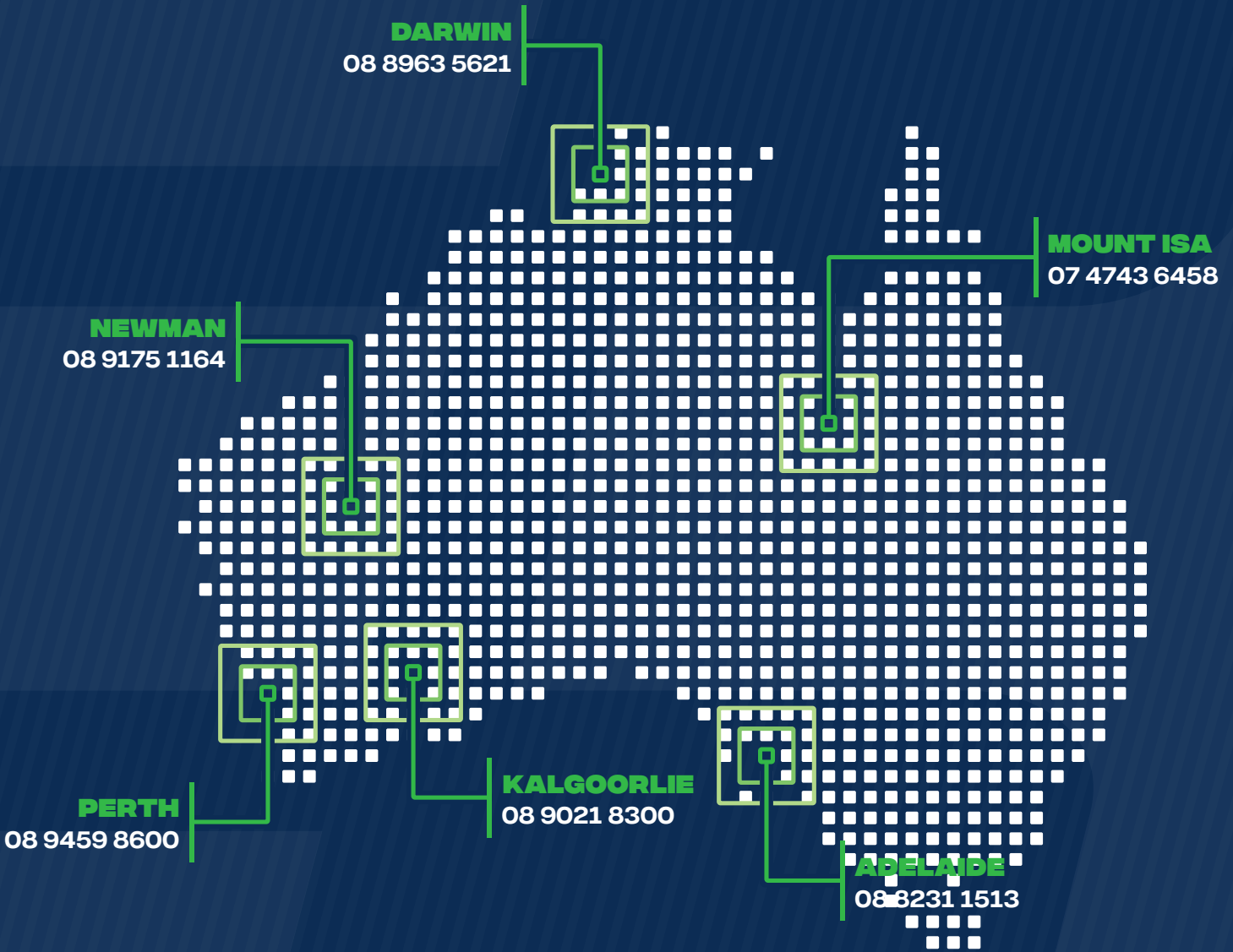

 sales@bendtechgroup.com.au

 www.bendtechgroup.com.au

