

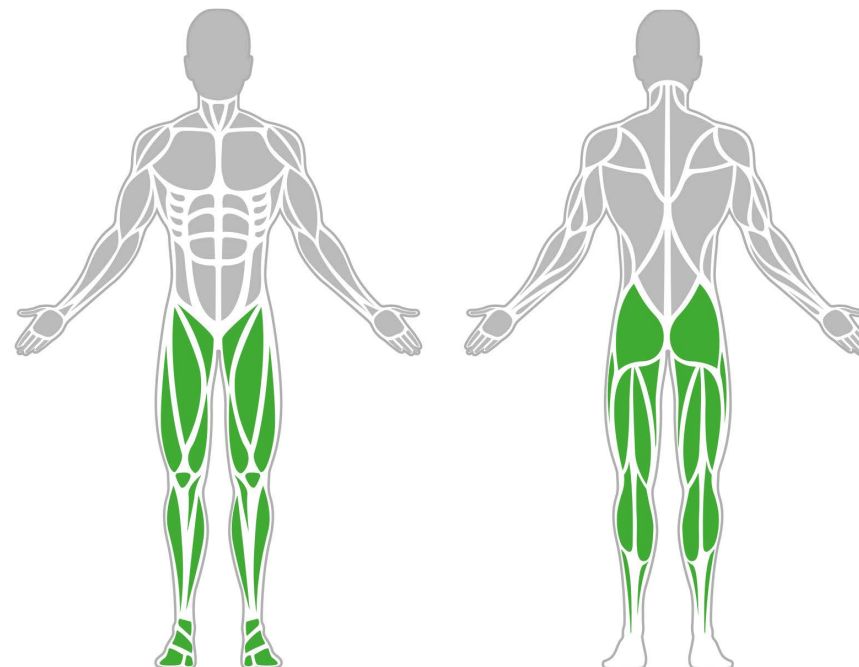

Muscle Groups Focus



Steppers 500

The stepper is one of the simplest exercise equipment that is excellent for strengthening the leg muscles, buttocks and sculpting the body as part of a bodyweight workout. It is especially recommended for athletes to develop a centre of gravity lift. The difficulty of the exercises can be increased by choosing from a range of steppers of different heights or by using accessories. The steppers usually consist of 3-5 elements, but can be extended to more or as little as a single element can be requested.

Attributes

Product code	1-1-013
Certificate	EN 16630
Age group	14 + years
Capacity	1 person
Max. weight load	99 kg
Type	Fitness
Difficulty level	Easy

Side View

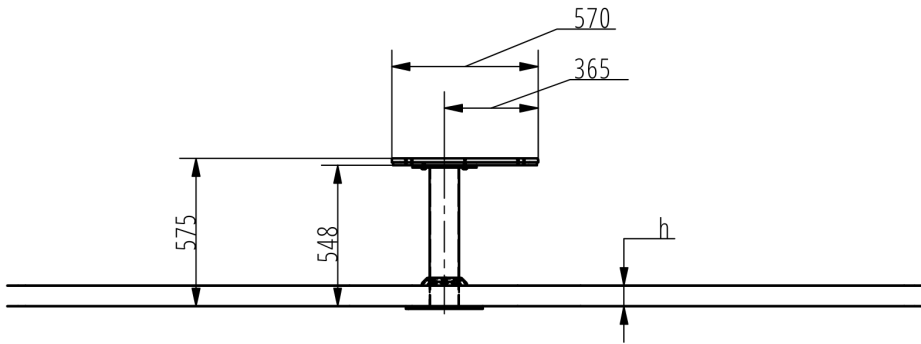

Plan View

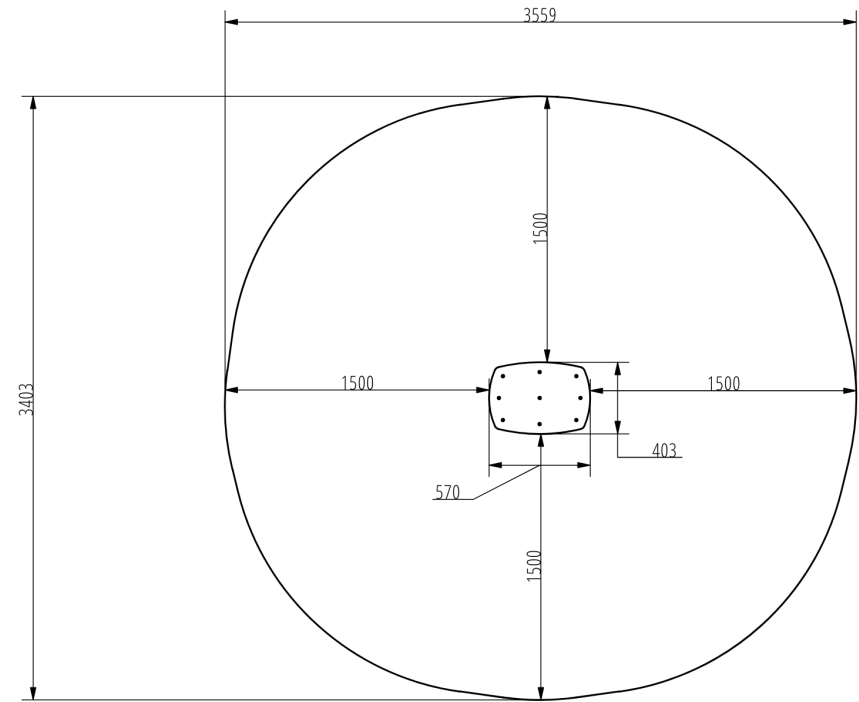

Installation information

Number of installers (concrete)	At least 2 people
Total installation time (concrete)	60-120 min.
Number of installers (equipment)	At least 2 people
Total installation time (equipment)	15-25 min.
Excavation volume	0.512 m ³
Concrete volume	0.512 m ³
Size of the base structure	0,8 x 0,8 x 0,8 m
Anchoring options	In-ground or surface
In combined structures, the volume of concrete required varies.	

Technical specification

Safety surface area	Around 1,5 m radius
Net weight	40 kg
Material	S235
Critic fall height	585 mm
Color options	

For more color options, discuss with your sales representative.

Warranty

Structure	25-15 years
Steel	5-10 years
Paint	2 years
Plastic	5-10 years
Rubber	1-3 years
Moving parts	2 years
Detailed information in the warranty document	

Material specification

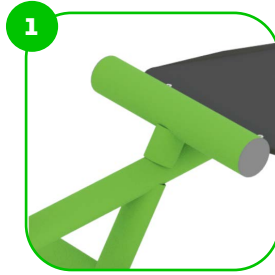

The element is made of high quality S235 steel, which has been cleaned via sandblasting. A corrosion resistant powder coating finish is then applied. Also available with galvanized surface for even greater protection and longevity!



The top surface of the device is covered with the highest quality non-slip HDPE.



The connecting elements are fastened with vandal-proof stainless steel screws and nuts.

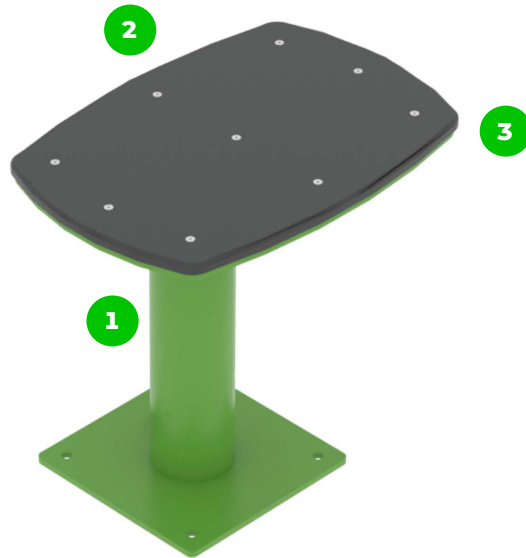

BESTSTRONG

 [beststrongworld](#)  [beststrongworld](#)  [global.beststrong.com](#)  info@beststrong.com

