



FURNISYSTM
FUNCTIONAL FURNITURE SYSTEMS

Storage Systems that help you optimise your workspace

Office Workspace Brochure



WHY FURNISYS ?

At Furnisys, we aim to improve the quality of workspaces which in turn exponentially boosts the efficiency and bottom line of the company. Our systems help you enhance your workspaces dynamics through:



Lean Thinking

Improve productivity by combining lean initiatives with value stream mapping and 5S with our solution



The System Concept

All products can be freely integrated & combined



Custom Play

For customers with specific needs



Maximum Flexibility

With choice of colours, configuration options & more



Buying Guide

Selection guides, Product Comparisons, Case Studies, Reference Work Gallery



Ergonomics

Product designs helps to minimize injuries & help maximize productivity



Comprehensive Range

Multiple product options for your operational needs



Expert Planning

with 3D modeling visualization software



Wide Range of Service

Such as Installation, After-sales support etc.



Made in INDIA

Committed to manufacturing highest quality of metal based industrial furniture in INDIA

Our Value chain

Engineering Design

Value Addition, R&D

Project Management

Individualized attention, Time-Sensitive

Product Management

Value Delivery, Consistency

Sales & Marketing

Solutions, Engagement

Manufacturing Infrastructure:

Furnisys is supported by multiple self-owned factories located in over 25,000 sq.ft. in Navi Mumbai. Manufacturing all products in-house provides us with the opportunity to control 100% of the product quality and ability to facilitate projects of all sizes while maintaining competitive pricing and outstanding lead times. All of the factories feature the latest machinery and technology available to use.

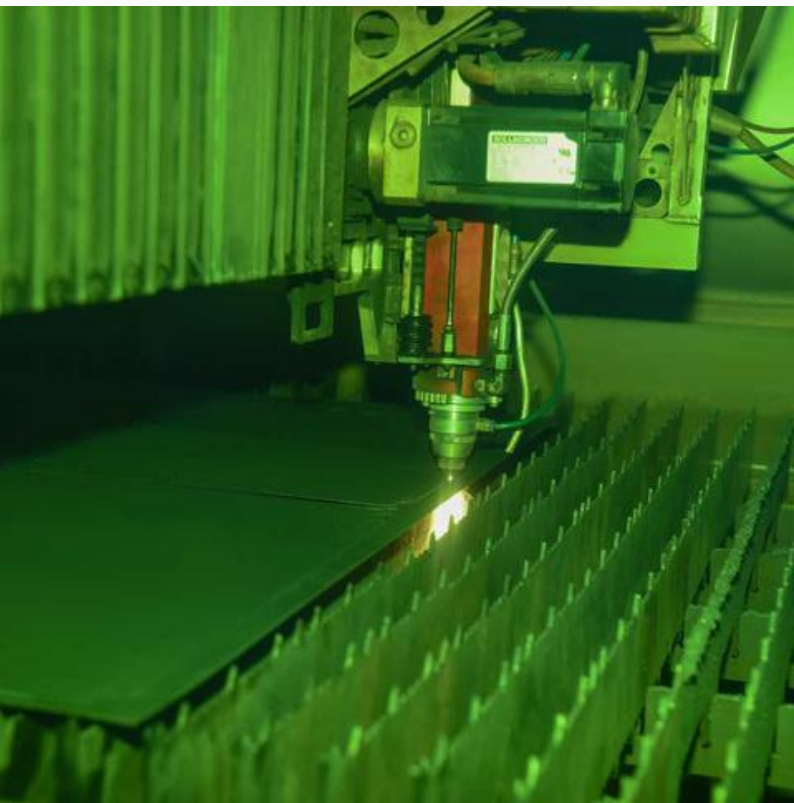
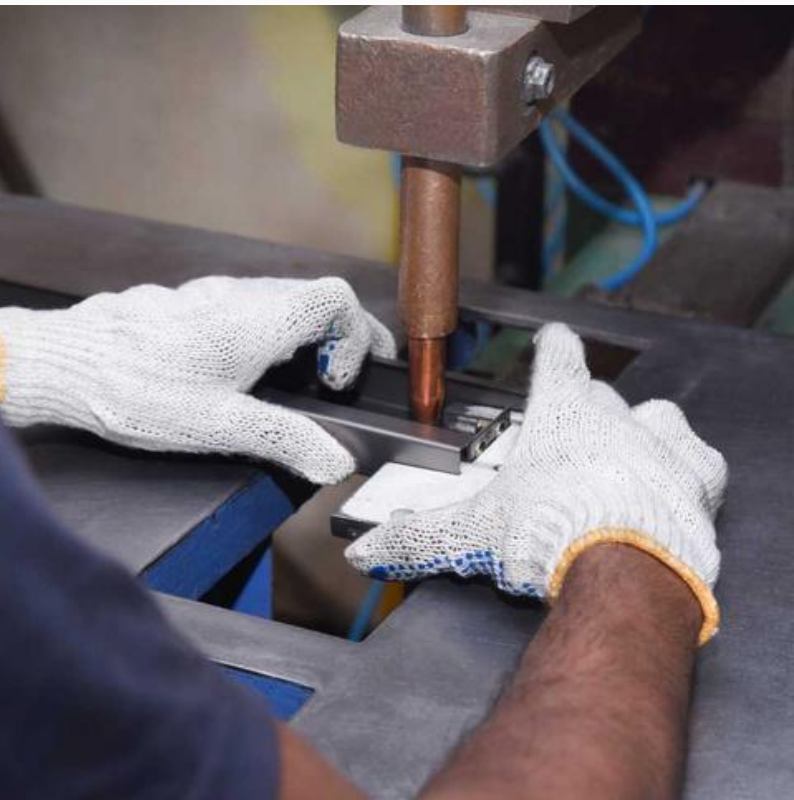

Products

01 pg

Mobile
Shelving
System

03 pg

Lockers
Personal Lockers
Mobile Lockers



Use space to **Your Advantage.**

Designating storage items to specific organized spaces increases productivity by 87%



About Furnisys

We specialize in creating adaptable and versatile solutions for various industries, enhancing the efficiency and productivity of any space.

With a commitment to quality and continuous improvement, we deliver integrated furniture systems that meet the dynamic needs of our clients.

Our Story

Furnisys emerged from a realization that our traditional approach as "Furnace" needed to evolve to meet the changing demands of our clients. Initially focused on designing and executing metal furniture projects for Laboratory, Office Storage, and Manufacturing Spaces, we recognized the need for more integrated and versatile solutions.

This insight led to our rebranding as Furnisys, a name inspired by "Furniture Systems." Today, we are dedicated to providing innovative systems tailored to various applications, driven by continuous research and customer collaboration.



01 Mobile Shelving System

Load Capacity: 40-50 Kg/Cmprt

Secured Storage

Adaptable Design

More Storage in Less Space

Reduce Costs

Less Time Wastage

Improve Productivity

Increased Protection

Futuristic Approach

Mobile Shelving System allows you to create additional storage space within the existing area. This means you can use more of your valuable space, more profitably.



Features

Push / Pull,
Mechanical System

Anti-Tilting
mechanism

Adjustable
Shelving

Individual
Locking

Optional Central
Locking



Save upto 60% Space

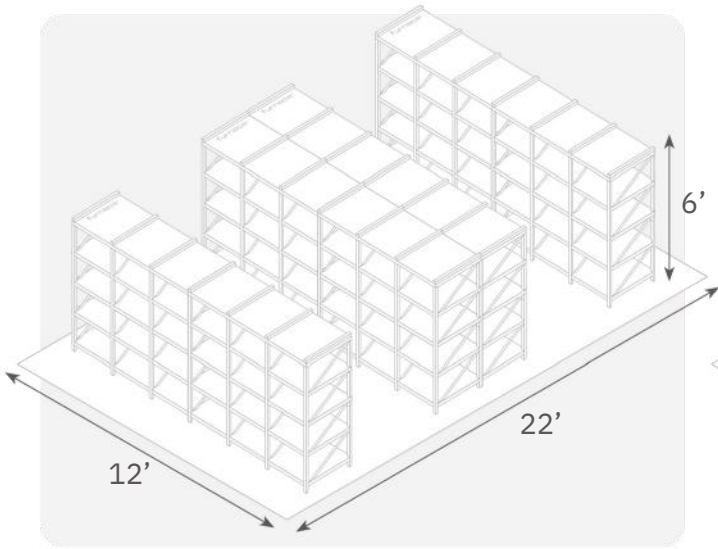

Regular Setup

Space Utilized - 1584 cu ft

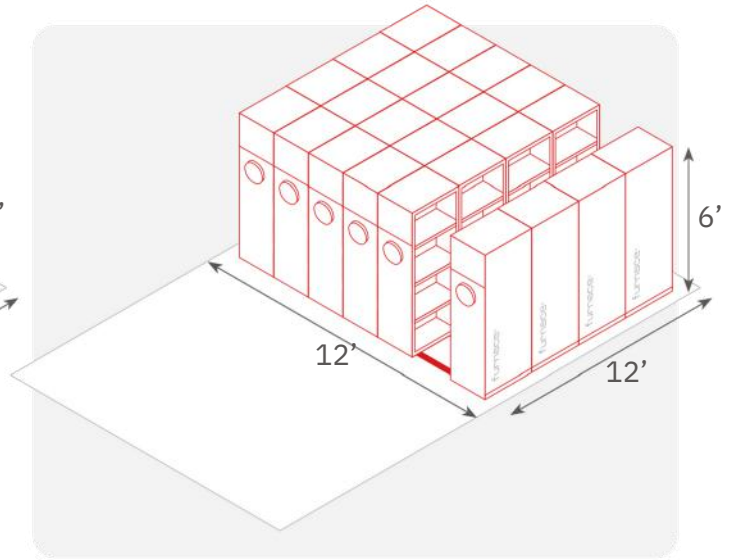

Compactor Setup

Space Utilized - 864 cu ft

Application



Offices

Pharmacies

Medical Practices

Galleries and Museums

Educational Facilities and libraries

Laboratories

Benefits

Improve Productivity

Compactor storage system promotes organization of materials, increasing employee morale and productivity.

More Storage in less space

Making use of only a single accessible aisle, nearly doubles the storage capacity of the archive space. Create extra space for revenue driven activities.

No more Time wastage

Centralized storage allows you to make it easier and faster for employees to retrieve and store goods.

Futuristic Approach

Having a compactor makes storage clean, systematic and enclosed from visitors eyes. Additionally it increases the aesthetic value of the company.

Increased Protection

The Compactor is fitted with a central locking system which allows you to have a one point controlled access. Loaded items and files are safe from theft or damage.

Reduce Costs

Reduces energy operating costs to cool, heat, light, and maintain your building or lease space.

02 Lockers

Visually Appealing Strong & Sturdy

Ventilated Spacious Storage

Reduces Clutter Secured Workspace

Furnisys offers an extensive range of application-based robust locker solutions, which include - individual storage lockers, shared storage spaces, and storage for small articles like mobile phones and wallets.

Personal Lockers

Providing lockers for employees to store their personal belongings reduces clutter from the workspace and keeps items safe and secure.



Grande Series

- 20-25kg/Compartment
- Numeric Locking
- Double Skin Door In-built Metal Handle
- Plinth Base
- Optional Slopy Top

Classic Series

- 20-25kg/Compartment
- Cam Locking
- Single Skin Door Recess Handle
- Frame Base
- Optional Slopy Top



Suitable for storing personal belongings

Mobile Locker

Define the work culture in your company by using lockers specifically to keep mobile phones, wallets, keys.

Using a mobile locker helps in reducing distraction during work and having control over what's happening in your work environment. Maximise your storage space by choosing the right solution for the appropriate requirement.

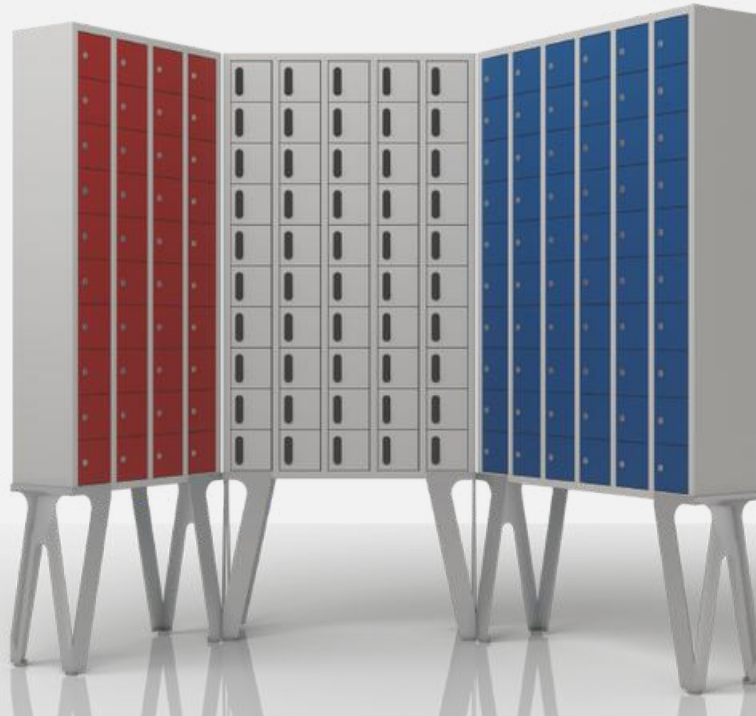

Features



3-5kg/
Compartment

Cam/ Numeric
Locking

Wall Mounting
Provision

Frame/ Leg Base

Optional Slopy Top



Suitable for storing Mobiles/wallets

CLIENTELE

adani™



Smith+Nephew

SHIMANO®



LIEBHERR



KOHLER®



Dräger



KOHLI



Fabtech India, EL-21 TTC Industrial
Area, Mahape,
Navi Mumbai - 400 710
+ 91 7045763012
enquiry@furnisys.co

www.furnisys.co

FURNISYS /   

