

- ▶ Catálogo General
- ▶ General Catalogue
- ▶ Catalogue Générale

WININGLAND
Quality is our aim



Trituración
Crushing
Concassage

P/5-10

Clasificación
Classification
Clasification

P/11-17

Equipos sobre Ruedas y Orugas
Wheeled & Tracks Equipments
Equipements sur Roues et Chenilles

P/19-23

Lavado
Washing
Lavage

P/25-30

Alimentadores
Feeders
Alimentateurs

P/31-36

Transportadores
Conveyors
Convoyeurs

P/37-39

Detectores
Detectors
Détecteurs

P/41-43

Recambios-Accesorios
Parts-Accessories
Rechanges-Accessoires

P/45-51



Trituración
Crushing
Concassage

1

JC

Triturador de Mandíbulas Jaw Crushers Concasseur à Mâchoires

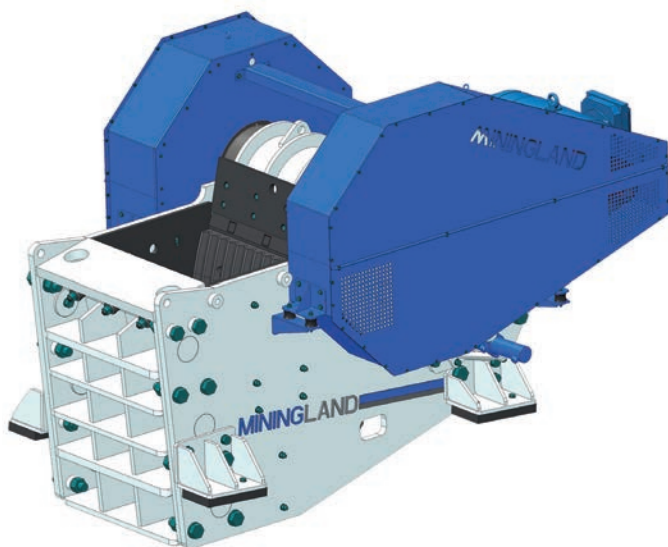

capacidades capabilities capacités Tn/h.

Tamaño de producto Product size Taille de produit (mm)	Reglaje lado cerrado Closed-side setting Réglage du côté fermé (mm)	JC-1070	JC-1290	JC-1411	JC-1613
0-120	80	150-200			
0-150	100	190-250	220-300		
0-180	120	230-300	260-380	300-430	
0-210	140	270-350	320-430	350-500	400-600
0-230	160	300-400	360-500	390-550	480-700
0-270	180	330-450	400-590	430-600	510-730
0-300	200	360-500	450-630	500-700	580-850
0-330	220		500-730	550-750	630-900
0-375	250			600-820	690-1000
0-430	280				760-1100
0-480	310				850-1250

especificaciones técnicas technical specifications spécifications techniques

Modelo Model Modèle	Dimensiones de entrada Input size Dimensions d'entrée (mm)	Potencia Power Puissance (kw)	Velocidad Speed Vitesse (rpm)	Peso Weight Poids (kg)
JC - 1070	1000 x 700	90	270	17000
JC - 1290	1200 x 900	132	240	31500
JC - 1411	1400 x 1100	200	225	51000
JC - 1613	1600 X 1250	250	200	82000

Triturador Primario
Primary Crusher
Broyeur Primaire

PC

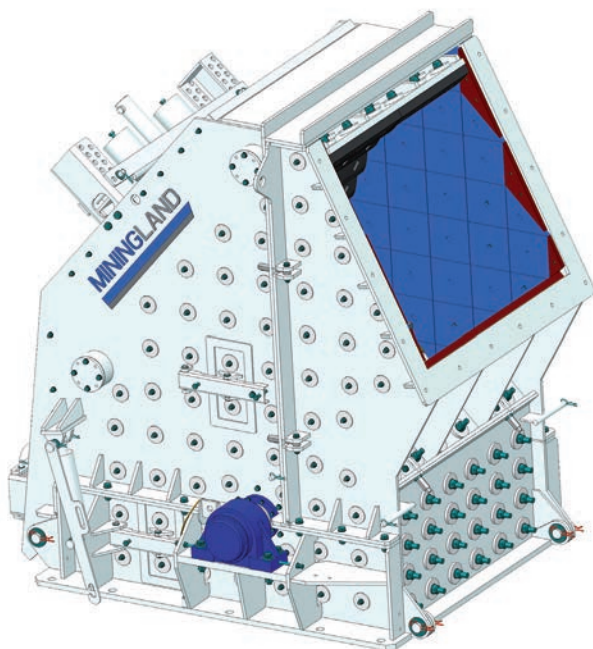

Modelo Model Modèle	Ancho alim. Feed width Largeur d'alim. (mm)	Alto alim. Feed height Hauteur d'alim. (mm)	Ø Rotor Ø Rotor Ø Rotor (mm)	Configuración Configuration Configuration	Tamaño alim. Feed size Taille d'entrée (mm)	Hileras de barrones Rows of bars Rang. de battoires	Peso Weighty Poids (kg)	Potencia Power Puissance (kw)	Producción Production Capacité (Tn/h)
PC 300	1230	1200	1240	Primario Primary Primaire	900	5	21000	160 - 200	250 - 350
PC 400	1425	1200	1240	Primario Primary Primaire	900	5	26000	200 - 250	350 - 450
PC 500	1635	1200	1240	Primario Primary Primaire	900	5	30500	250 - 335	450 - 600
PC 700	2040	1200	1240	Primario Primary Primaire	900	5	34000	355 - 400	600 - 800

IC

Triturador de Impacto Impact Crusher Broyeur Impacteur

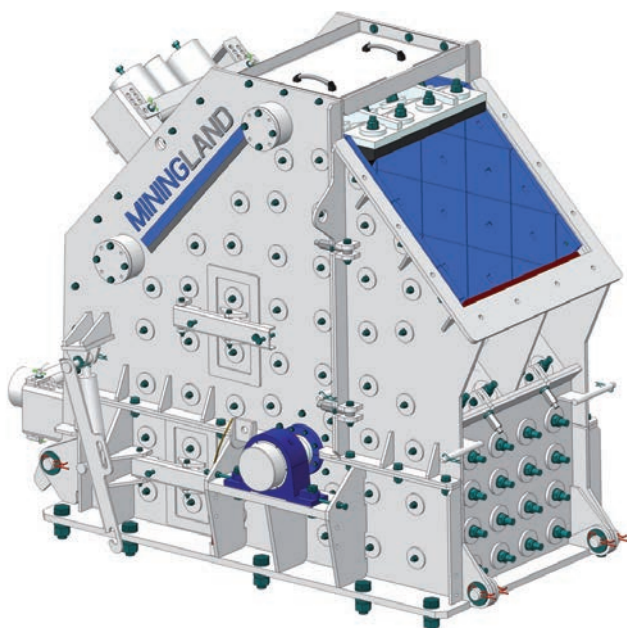

Modelo Model Modèle	Ancho alim. Feed width Largeur d'alim. (mm)	Alto alim. Feed height Hauteur d'alim. (mm)	Ø Rotor Ø Rotor Ø Rotor (mm)	Configuración Configuration Configuration	Alimentación Feed Entrée (mm)	Hileras de barrones Rows of bars Rangées de battoires	Peso Weight Poids (kg)	Potencia Power Puissance (kw)	Producción Production Capacité (Tn/h)
IC-220	815	880	1240	Primario / Primary / Primaire	650	5	12000	110 - 160	200 - 250
				Secundario / Secondary / Secondaire	300	5	11000	132 - 160	180 - 220
				Terciario / Tertiary / Tertiaire	250	4	10700	132 - 160	180 - 220
IC-300	1220	880	1240	Primario / Primary / Primaire	700	5	15500	132 - 200	250 - 350
				Secundario / Secondary / Secondaire	300	5	14500	160 - 250	250 - 300
				Terciario / Tertiary / Tertiaire	250	4	14000	160 - 250	250 - 300
IC-400	1625	880	1240	Primario / Primary / Primaire	700	5	19000	200 - 250	300 - 500
				Secundario / Secondary / Secondaire	300	5	17500	200 - 315	300 - 400
				Terciario / Tertiary / Tertiaire	250	4	16700	200 - 315	300 - 400
IC-500	2030	880	1240	Primario / Primary / Primaire	700	5	22000	250 - 355	400 - 600
				Secundario / Secondary / Secondaire	300	5	20000	315 - 400	400 - 550
				Terciario / Tertiary / Tertiaire	250	4	19000	315 - 400	400 - 500

Triturador Eje Vertical
Vertical Shaft Impactor
Broyeur à Axe Vertical

VSI

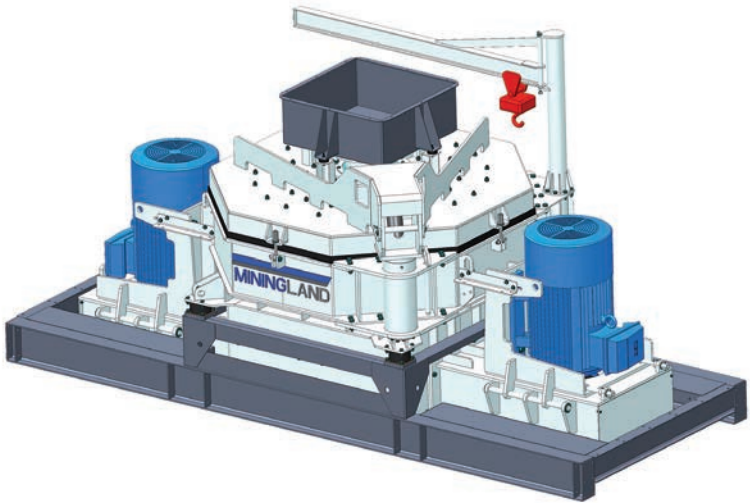

Modelo Model Modèle	Configuración Configuration Configuration	Alimentación máx. Máx. feed Alimentation máx. (mm)	Velocidad máx. Máx. speed Vitesse máx. (m/s)	Ø Rotor (mm)	Producción máx. Máx. Production Production máx. (Tn/h)	Giro Rotation Tour	Potencia Power Puissance (kw)	Peso Weight Poids (kg)
VSI - 1000	R - R	50	75	1000	450	Unidireccional Single direction Unidirectionnel	200-400	8000
	2 - R - R	50	75	1000	600	Unidireccional Single direction Unidirectionnel	200-400	9000
	R - Y	50	75	1000	450	Unidireccional Single direction Unidirectionnel	200-400	10000
	E - Y	120	75	1000	350	Reversible Reversible Réversible	200-400	10000
VSI - 850	R - R	40	80	850	220	Unidireccional Single direction Unidirectionnel	110-200	7000
	2 - R - R	40	80	850	300	Unidireccional Single direction Unidirectionnel	110-200	8000
	R - Y	40	80	850	220	Unidireccional Single direction Unidirectionnel	110-200	9000
	E - Y	100	80	850	200	Reversible Reversible Réversible	110-200	9000

CC

Triturador de Cono Cone Crusher Broyeur à Cône

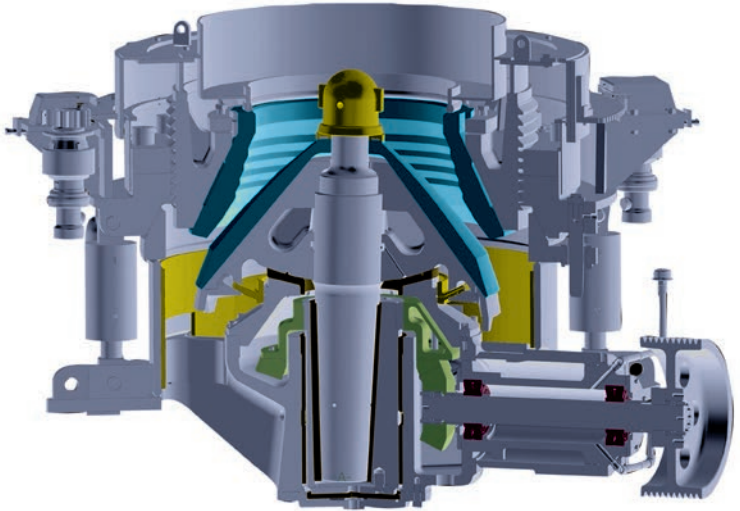

Modelo / Model Modèle	Apertura / Opening Overture: Max (mm)	Ajuste / Setting Adjustment: Min (mm)	Potencia / Power / Puissance (kw)	Capacidad (Tn/H) según apertura descarga (mm) Capacity (TPH) at closed side discharge opening size (mm) Capacité (Tn/H) selon ouverture discharge (mm)							Peso / Weight / Poids (kg)		
				13	16	19	22	25	32	38		45	51
CC-100-C	135	16	75-112		75-78	80-95	85-100	90-110	100-130				6.800
CC-100-F	105	16	75-112		55-70	65-80	70-85	75-95	90-110				6.800
CC-200-C	185	19	110-150				180-210	200-240	235-270	265-310			12.000
CC-200-F	145	17	110-150			145-165	160-195	185-220	210-245	230-280			12.000
CC-200-S	70	13	110-150	90-110	105-125	120-135	125-140	130-150	140-165				12.000
CC-300-C	210	22	180-225				210-240	230-280	270-320	290-350	320-380	360-430	18.700
CC-300-F	185	19	180-225			190-220	205-230	255-260	245-285	270-330	300-350		18.700
CC-300-S	90	16	180-225		135-155	150-170	165-185	180-200	200-220				18.700
CC-400-C	290	25	220-300					295-335	335-375	370-480	430-500	470-550	28.400
CC-400-F	210	22	220-300				265-310	290-330	315-360	350-410	390-440		28.400
CC-400-S	110	16	220-300		155-185	175-200	195-225	210-245	235-256				28.400

Clasificación
Classification
Classification

2

GS

Criba de Barras Grizzly Screen Crible Scalpeur

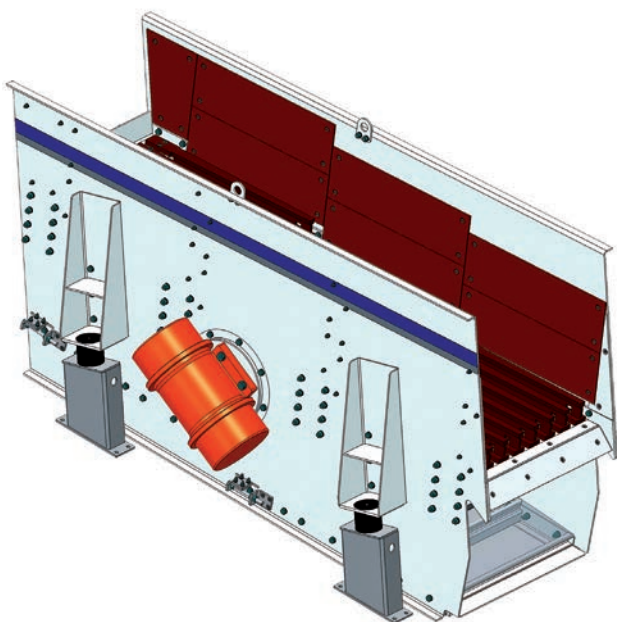

Modelo Model Modèle	A	B	C	D	E	Longitud Length Longueur (mm)	Ancho Width Largeur (mm)	Producción Production Production (Tn/h)*	Peso Weight Poids (kg)	Potencia Power Puissance (kw)
GS-18	1000	1340	2372	2300	1400	2000	1000	200	3100	7,6
GS-22	1100	1440	2372	2300	1400	2000	1100	250	3225	7,6
GS-36	1200	1540	3372	3300	1500	3000	1200	400	4350	14,2
GS-42	1400	1740	3372	3300	1500	3000	1400	500	4750	14,2
GS-56	1400	1740	4372	4300	1600	4000	1400	650	5350	15
GS-64	1600	1940	4372	4300	1600	4000	1600	800	5625	15
GS-80	2000	2340	4372	4300	1600	4000	2000	1000	5980	15,5
GS-96	2400	2740	4372	4300	1600	4000	2400	1200	6540	20

*La producción es orientativa y depende del tipo de producto, de su granulometría y de la clasificación que se pretende. *The output value provided is an estimation and depends on the kind of product, its grain size and the intended grading. * La production est indicative et dépend du type de produit, de sa granulométrie et de la classification souhaitée.

Criba Vibrante Vibrating Screen Crible Vibrant

VS



Modelo Model Modèle	Longitud Length Longueur (mm)	Ancho Width Largeur (mm)	Superficie Surface area Surface (m ²)	Mecanismo No of mechanism Mécanisme			Potencia (kw) Power (kw) Puissance (kw)		
				Pisos / Sieving / Étages			Pisos / Sieving / Étages		
				II	III	IV	II	III	IV
VS-36	3000	1290	3,6	1	1	1	7,5	7,5	7,5
VS-60	4000	1590	6	2	2	2	15	15	15
VS-75	5000	1590	7,5	2	2	3	15	15	18
VS-90	5000	1890	9	2	3	3	15	18	18
VS-108	6000	1890	10,8	3	3	4	18	18	22
VS-126	6000	2190	12,6	3	3	4	18	18	22
VS-147	7000	2190	14,7	3	4	4	18	22	22
VS-168	7000	2490	16,8	4	4	5	22	22	30
VS-189	7000	2790	18,9	4	5	5	22	30	30

VSF

Criba Especial Finos Special Screen for Fines Crible Spécial pour Fines



Modelo Modèle	N° pisos No of decks N° pisos	Anchura de cribado Screening width Largeur de criblage (mm)	Longitud de cribado Screening length Longueur de criblage (mm)	Potencia Power Puissance (kw)	FC CF FC (kp)	Peso Weight Poids (kg)
VSF36-II	2	1200	3000	2 X 3,6	11000	2700
VSF36-III	3	1200	3000	2 X 5	14400	3850
VSF45-II	2	1500	3000	2 X 5	14400	3050
VSF45-III	3	1500	3000	2 X 7,5	18000	4200
VSF54-II	2	1800	3000	2 X 5	14400	3250
VSF54-III	3	1800	3000	2 X 7,5	18000	4600
VSF72-II	2	1800	4000	2 X 7,5	18000	4500
VSF72-III	3	1800	4000	2 X 11,5	29000	6700

Filtro de Mangas Sleeve Filters Filtres à Manches

DF

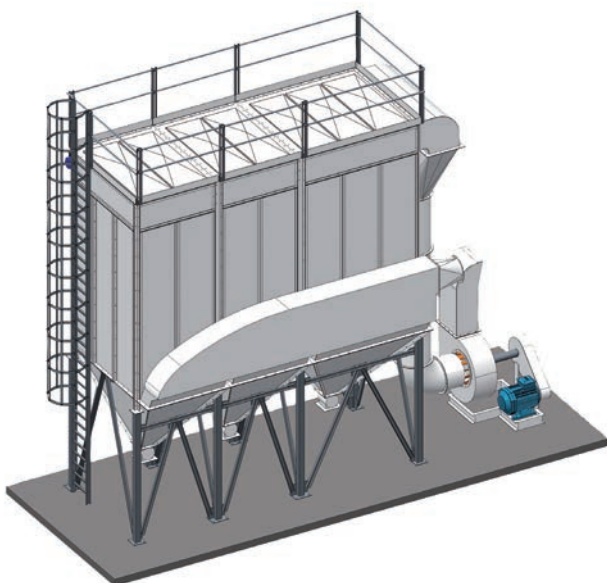

Modelo Model Modèle	Producción Production Production m ³ /h	Nº Módulos / Nº Modules / Nº Modules		Nº Mangas Nº Steeves Nº Manche	A
		Nº Válvulas / Nº Valves Nº Vannes	Nº Válvulas / Nº Valves Nº Vannes		
DF-08	8000	1	0	88	1680
DF-12	12000	0	1	132	2480
DF-16	16000	2	0	176	3440
DF-20	20000	1	1	220	4240
DF-24	24000	0	2	264	5040
DF-28	28000	2	1	308	6000
DF-32	32000	1	2	352	6800
DF-36	36000	0	3	396	7600
DF-40	40000	2	2	440	8560
DF-44	44000	1	3	484	9360
DF-48	48000	0	4	528	10160

SD

Desfillerizado Arena Vía Seca Desfillerized Sand Dry Method Defillerisé Sable Voie Sèche

Procesos de lavado y recomposición granulométrica por vía SECA.

Washing and grading amended processes by DRY methods.

Procédures de lavage et recomposition granulométrique par voie SÈCHE.

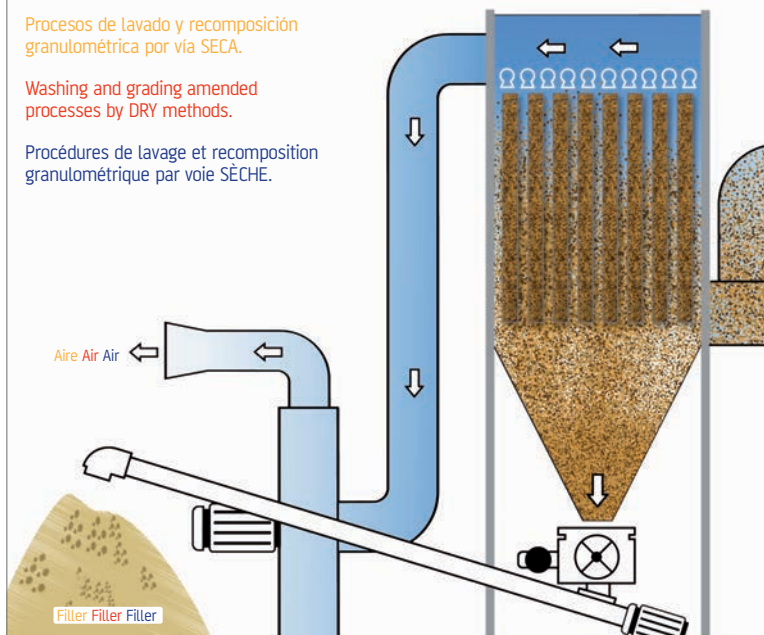

	Ventilador / Ventilator / Ventilateur		Filtro / Filter / Filtre		Criba / Screen / Crible		
Modelo / Model / Modèle	Capacidad / Capacity / Capacité (m³/h)	Potencia / Power / Puissance (Kw)	Nº Mangas / No Hose / Nº Tuyau	Sup. Filtrante / Filter surface / Zone de filtre (m²)	Modelo / Model / Modèle	Capacidad arena / Sand capacity / Capacité de sable (Tn/h)	0-4 mm
DSD-40	8000	18,5	88	117	36-II	40	
DSD-60	12000	30	132	176	45-II	60	
DSD-80	16000	37	176	234	54-II	80	
DSD-120	24000	55	264	351	72-II	120	
DSD-160	32000	75	352	468	2 x 54-II	160	

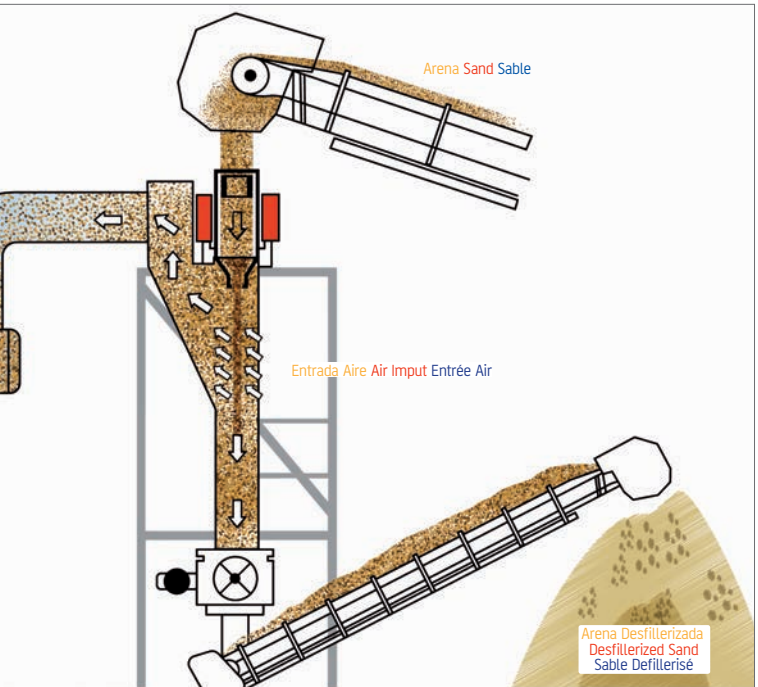



**Equipos sobre
Ruedas y Orugas
Wheeled & Tracks
Equipments
Equipements sur
Roues et Chenilles**

3

Equipos sobre ruedas Wheeled equipment Equipement sur roues

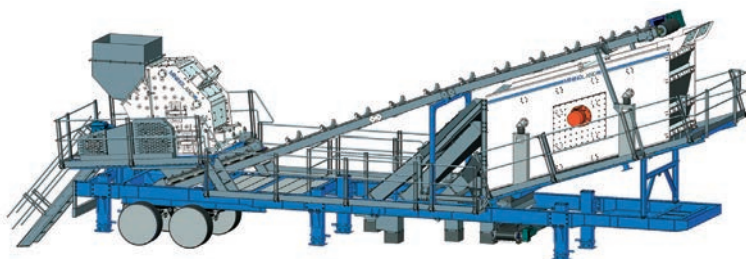
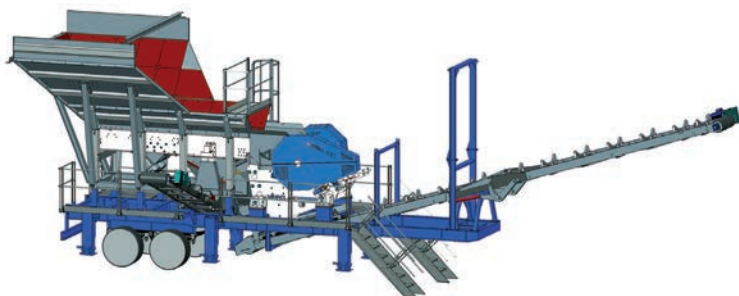
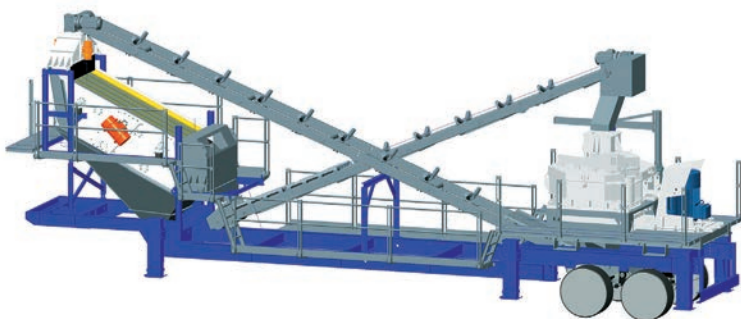

TUAREG



TRITURACIÓN

- **Primarios:**
 - Impactores
 - Trituradores de mandíbulas

- **CLASIFICACIÓN:**
 - Cribas de barrotes primarias
 - Cribas inclinadas

- **Secundarios:**
 - Impactores
 - Conos

- **Terciarios:**
 - Conos
 - Molinos de Eje Vertical

- **OTROS:**
 - Trituradores con criba
 - Combinaciones de trituradores
 - Equipos a medida



CRUSHERS

- **PRIMARY:**
 - Impact crushers
 - Jaw crushers

- **CLASIFICATION:**
 - Grizzly screen
 - Vibrating screen

- **Secondary:**
 - Impact crushers
 - Cone crusher

- **Tertiary:**
 - Cone crusher
 - Vertical shaft impactor

- **OTHERS:**
 - Crushers with screens
 - Crushers combinations
 - Customer built equipment



CONCASSAGE

- **Primaires:**
 - Broyeur impacteur
 - Concasseur à mâchoires

- **CLASIFICATION:**
 - Crible scalpeur
 - Crible vibrant

- **Secondaires:**
 - Broyeur impacteur
 - Broyeur à cône

- **Tertiaires:**
 - Broyeur à cône
 - Broyeur à axe vertical

- **AUTRES:**
 - Broyeurs avec crible
 - Combinaisons des broyeurs
 - Equipements en fonction des besoins du clients

Equipos sobre orugas Tracks equipment Equipement sur chenilles

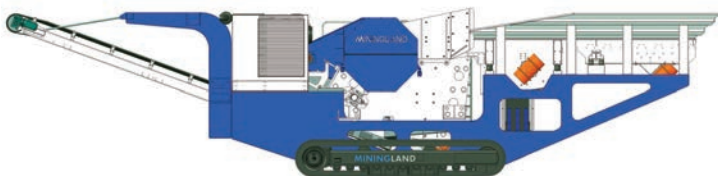
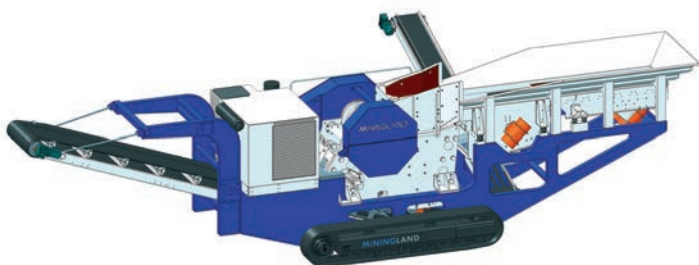
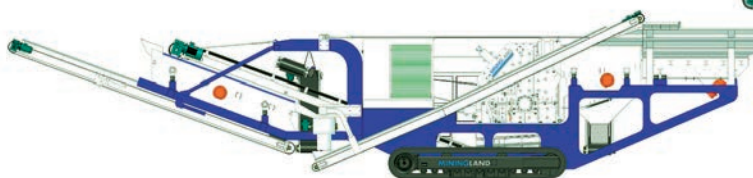

TRACKS



TRITURACIÓN

• Primarios:

- Impactores
- Trituradores de mandíbulas

CLASIFICACIÓN:

- Cribas de barrotes primarias
- Cribas inclinadas

• Secundarios:

- Impactores
- Conos

• Terciarios:

- Conos
- Molinos de Eje Vertical

OTROS:

- Trituradores con criba



CRUSHERS

• PRIMARY:

- Impact crushers
- Jaw crushers

CLASIFICATION:

- Grizzly screen
- Vibrating screen

• Secondary:

- Impact crushers
- Cone crusher

• Tertiary:

- Cone crusher
- Vertical shaft impactor

OTHERS:

- Crushers with screens



CONCASSAGE

• Primaires:

- Broyeur impacteur
- Concasseur à mâchoires

CLASIFICATION:

- Crible scalpeur
- Crible vibrant

• Secondaires:

- Broyeur impacteur
- Broyeur à cone

• Tertiaires:

- Broyeur à cone
- Broyeur à axe vertical

AUTRES:

- Broyeurs avec crible





Lavado
Washing
Lavage

4

DW

Tromel Lavador Drum Washer Trommel de Lavage



Modelo /Model Modèle	Longitud tambor Drum Length Longueur cylindre (mm)	Ø Tambor Ø Drum Ø Cylindre (mm)	Ruedas motrices Drive wheels Roues motrices	Ruedas portantes Wheels loaders Roues porteuses	Producción Production Production (Tn/h)	Potencia Power Puissance (Kw)
DW-120	5000	2100	6	6	120	3 x 7,5
DW-160	6000	2300	6	6	160	3 x 11
DW-240	7000	2500	6	6	240	3 x 15
DW-320	8000	2600	6	6	320	3 x 18,5
DW-400	9000	2800	8	8	400	4 x 18,5
DW-500	10000	3000	8	8	500	4 x 22

Lavador de Arena Sand Washer Laveuse de Sable

SW



Modelo Modèle	Ciclón Cyclone		Bomba Pump Pompe		Escorridor Drainer Égouttoir			Capacidad Capacity Capacité		Peso Weight Poids (Kg)
	Nº	Ø mm	Ø Impulsión Ø Impulsion Ø Impulsion (")	Potencia Power Puissance (Kw)	Modelo Modèle	Potencia Power Puissance (Kw)	Superficie Surface Surface (m ²)	Tn/h	m ³ /h	
SW-60	1	500	4	22	DS-60	2 x 1,8	2,7	60	40	5300
SW-80	1	650	6	30	DS-80	2 x 1,9	3,6	80	50	7000
SW-120	1	650	6	45	DS-120	2 x 2,2	4,5	120	75	8000
SW-160	2	650	8	60	DS-160	2 x 2,5	5,4	160	100	12600
SW-240	2	650	10	90	DS-240	2 x 3,6	8,4	240	150	16100

DS

Escurridor Vibrante Dewatering Screen Égouttoir Vibrant

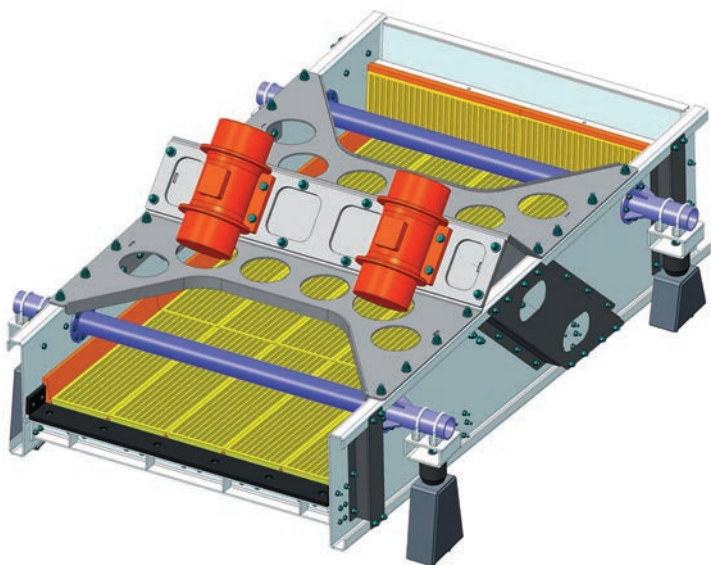

Modelo Model Modèle	Potencia Power Puissance (Kw)	Superficie Surface area Surface (m ²)	Longitud Length Longueur (mm)	Ancho Width Largeur (mm)	Producción Production Production (Tn/h)
DS-60	2 x 1,8	2,7	3000	990	60
DS-80	2 x 1,9	3,6	3000	1290	80
DS-120	2 x 2,2	4,5	3000	1590	120
DS-160	2 x 2,5	5,4	3000	1890	160
DS-240	2 x 3,6	8,4	4000	2100	240

NOTA: La producción es para arena 0-4 mm con una densidad de 1,6 Tn/m³

NOTA: This production is for 0-4mm sand with a density of 1.6t/m³

REMARQUE: La production est donnée pour un sable de 0-4 mm et d'une densité de 1,6 T/m³

Decantador de Lodos Sludge Thickener Décanteurs à Boues

ST

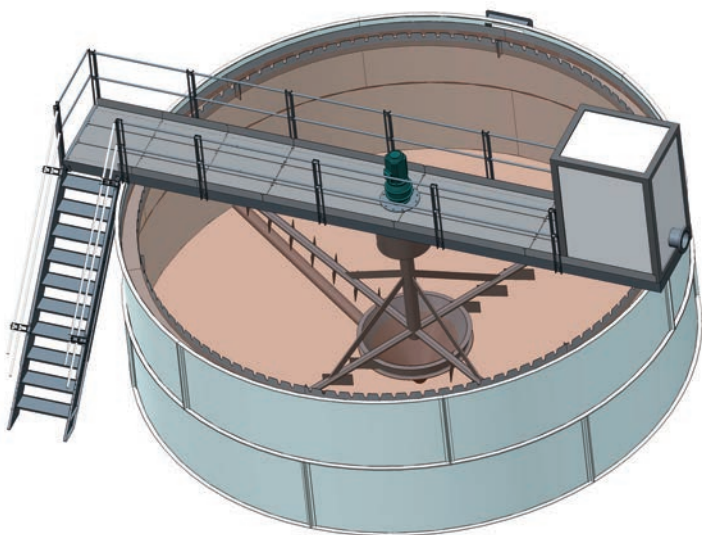

Modelo Model Modèle	Ø (m)	A	B	C	D	E	Potencia Power Puissance (Kw)	Bomba de lodos STD Mud pump STD Pompe à boues STD (Kw)	Capacidad Capacity Capacité (m³/h)
ST-120	5	5000	2500	3100	2100	1600	1,1	7,5	120
ST-200	6,5	6500	2500	3300	2100	1600	1,1	7,5	200
ST-300	8	8000	2500	3300	2100	1600	1,5	11	300
ST-450	10	10000	2500	3300	2100	1800	1,5	15	450
ST-650	12	12000	3000	4000	2600	1800	2,2	18,5	650
ST-800	14	14000	3000	4300	2600	1800	3	22	800

PF

Filtros Prensa Press Filter Filtre Presse

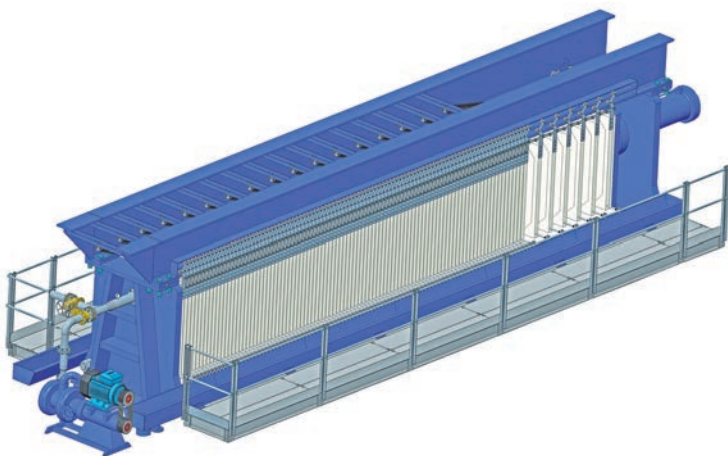

Modelo / Model Modèle	Dimensiones Placas Plates Dimension Dimension Plaques mm	Espesor Placas Plates Thickness Épaisseur Plaques mm	Espesor Tortas Cake Thickness Épaisseur Pâtes mm	Nº Tortas Nº Cakes Nº Pâtes	Vol. Total Tortas Cake Total Volume Vol. Total Pâtes m³	Presión Max. Max Pressure Pression Max. a.t.m.	Potencia Bomba Pump Power Puissance Pompe kw	*Capacidad Teórica *Theoretical Capacity *Capacité Théorique m³/h
PF-19	1500X1500	75	32	19	1,08	16	30	3,24
PF-25	1500X1500	75	32	25	1,43	16	30	4,29
PF-43	1500X1500	75	32	43	2,45	16	37	7,35
PF-55	1500X1500	75	32	55	3,14	16	37	9,43
PF-79	1500X1500	75	32	79	4,50	16	45	13,50
PF-103	1500X1500	75	32	103	5,87	16	45	17,61

* NOTA: La capacidad teórica está calculada a 3 ciclos hora, aunque depende de las características del lodo a tratar.

* NOTE: The theoretical capacity has been calculated with 3 cycles per hour, depending on the characteristics of the mud to treat.

* NOTE: La capacité théorique a été calculé par 3 cycles à l'heure, mais elle dépend des caractéristiques de la bou à filtrer.

Alimentadores
Feeders
Alimentateurs

5

AF

Alimentador de Placas Apron Feeder Alimentateur à Plaques

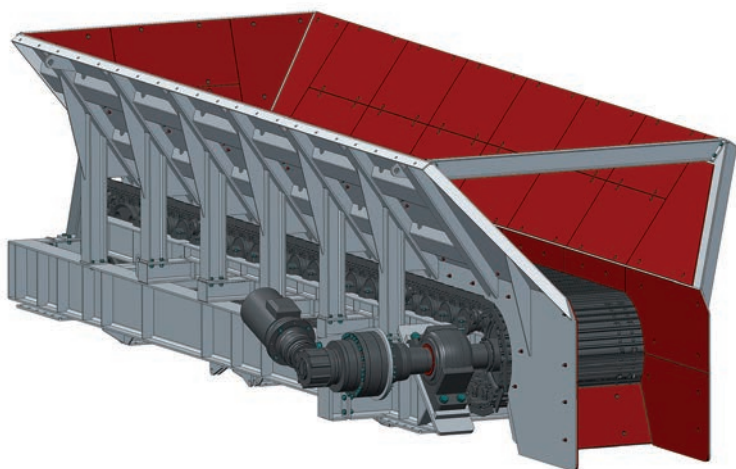

Modelo Model Modèle	Longitud Length Longueur (mm)	Ancho Width Largeur (mm)	Potencia Power Puissance (Kw)	Peso Weight Poids (Kg)
AF-410	4000	1000	11	10000
AF-412	4000	1200	11	11000
AF-610	6000	1000	18,5	13000
AF-612	6000	1200	18,5	15000
AF-814	8000	1400	30	21000
AF-816	8000	1600	30	23000
AF-818	8000	1800	37	25000
AF-820	8000	2000	37	27000

**Alimentador Precribador
Grizzly Feeder
Alimentateur Pré-cribleur**

GF

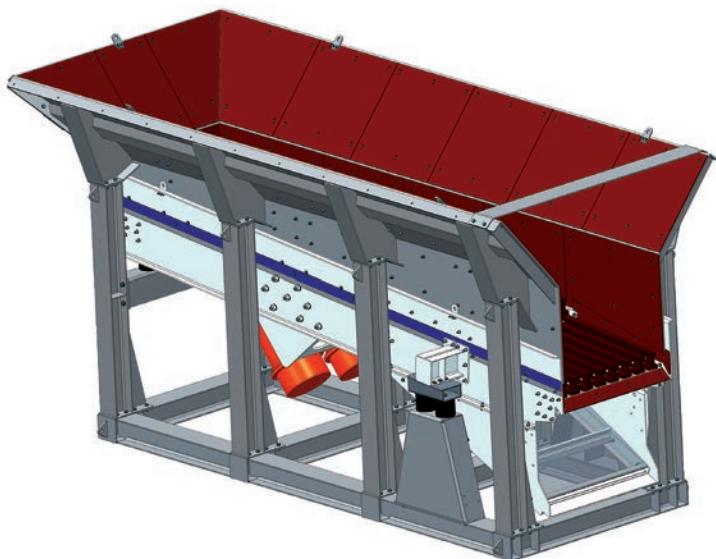

Modelo Model Modèle	Ancho Width Largeur (mm)	Longitud Length Longueur (mm)	Vibrador Vibrator Vibrateur	Potencia Power Puissance (Kw)	F. Cent. Cent. F F. Cent. (Kg)	Peso Weight Poids (kg)
GF-410	1000	4000	8000/10	2 x 7,1	8018	6000
GF-412	1200	4000	8000/10	2 x 7,1	8018	6700
GF-512	1200	5000	9000/10	2 x 7,5	8936	7800
GF-514	1400	5000	9000/10	2 x 7,5	8936	8150
GF-516	1600	5000	9000/10	2 x 7,5	8936	8500
GF-612	1200	6000	10000/10	2 x 7,6	9986	11000
GF-614	1400	6000	10000/10	2 x 7,6	9986	11900
GF-616	1600	6000	10000/10	2 x 7,6	9986	12950
GF-618	1800	6000	10000/10	2 x 7,6	9986	13850
GF-620	2000	6000	12000/10	2 x 9	12580	15000

RF

Alimentador de Vaivén Recyprocatng Feeder Alimentateur à Tiroir

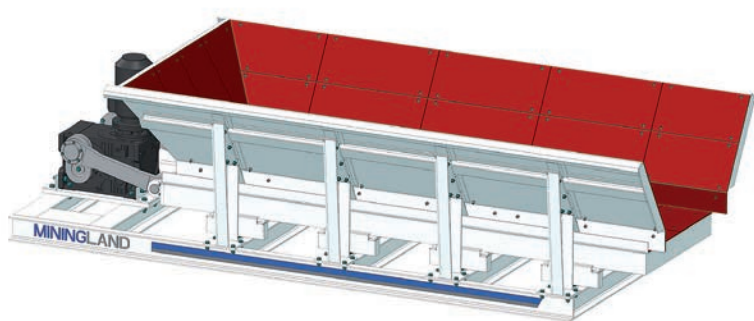

Modelo Model Modèle	Ancho Width Largeur (mm)	Longitud Length Longueur (mm)	Potencia Power Puissance (Kw)	Producción Production Production (Tn/h)
RF-308	800	3000	11	100-200
RF-410	1000	4000	15	200-400
RF-412	1200	4000	18,5	300-500
RF-414	1400	4000	22	350-600
RF-514	1400	5000	22	400-600
RF-516	1600	5000	30	500-800

NOTA: Podemos realizar otras medidas bajo pedido. NOTE: We can manufacture our feeders to other sizes on demand.

REMARQUE : nous pouvons faire d'autres mesures sur commande

**Alimentador Vibrante
Vibrating Feeder
Alimentateur Vibrant**

VF

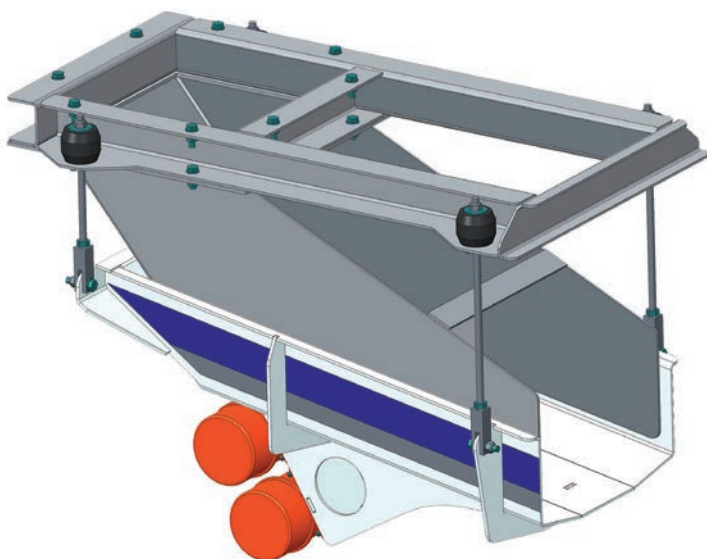

Modelo Model Modèle	Producción Production Production (Tn/h)	Vibrador Vibrator Vibrateur	Potencia Power Puissance (Kw)	Fureza Centrifuga Centrif. Force Force Centrifuge (kg)	Peso Weigth Poids (kg)
VF-100	100	550/15	1,24	1120	237
VF-150	150	700/15	1,24	1428	306
VF-200	200	1100/15	1,3	2228	370
VF-250	250	1100/15	1,3	2228	424
VF-300	300	1400/15	1,8	2728	529
VF-400	400	1700/15	2,3	3450	614
VF-500	500	2400/15	3,2	4716	710
VF-800	800	3000/15	3,8	6248	825

BF

Alimentador de Banda Belt Feeder Alimentateur à Bande

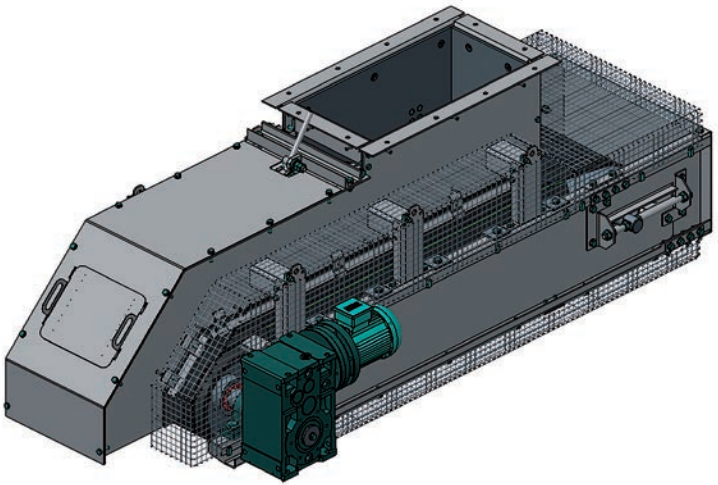

Modelo Model Modèle	Ancho Banda Belt Width Largeur Bande (mm)	Ø Tambores Ø Drums Ø Tambours (mm)	Potencia Power Puissance (Kw)	Producción Production Production (Tn/h)
BF-150	500	320	1,5	75-150
BF-250	650	320	2,2	150-250
BF-400	800	320	3	250-400
BF-600	1000	400	4	400-600

*Podemos fabricar bajo demanda otras longitudes *We can manufacture belts in other lengths on demand
*Nous pouvons fabriquer d'autres longueurs sur demande

**Transportadores
Conveyors
Convoyeurs**

6

CBR

Transportadores de Banda Conveyors Belt Convoyeurs à Bande



CBR Serie Media/Mid-Duty Range/Série Moyenne

Ø Tambor motriz / Driver drum / Tambour moteur	320 mm	320 mm	320 mm
SopORTE rodamientos / Bearing Support / Palier	UCP	UCP	UCP
Rodamientos / Bearings / Roulements	De bolas	Balls	A billes
Ø Tambor tensor / Tensor drum / Tambour tenseur	320 mm	320 mm	320 mm
SopORTE rodamiento / Bearing Support / Palier	UCFC	UCFC	UCFC
Rodamientos / Bearings / Roulements	De bolas	Balls	A billes
Estructura / Structure / Structure	Celosía	Celosía	Jalousie
Alto / Height / Hauteur	500 mm	500 mm	500 mm
Largueros / Rails / Longerons	L 60/6	L 60/6	L 60/6
Rodillos / Rollers / Rouleaux	Ø 89	Ø 89	Ø 89
Barras de impacto / Impact bars / Barres d'impact	55 mm	55 mm	55 mm

Transportadores de Banda Conveyors Belt Convoyeurs à Bande

CBH



CBH Serie Pesada/Heavy Duty Range/Série Lourde

500 mm ó más	500 mm ó más	500 mm ou plus
SNE	SNE	SNE
Rodillos a rótula	Ball&shocket joint Rollers	Rouleaux sphérique
500 mm	500 mm	500 mm
SNE	SNE	SNE
Rodillos a rótula	Ball&shocket joint Rollers	Rouleaux sphériques
Celosía	Celosía	Jalousie
700 mm	700 mm	700 mm
L 80/8	L 80/8	L 80/8
Ø 108 (hasta 1000 mm) Ø 133 (> 1000 mm)	Ø 108 (hasta 1000 mm) Ø 133 (> 1000 mm)	Ø 108 ((jusqu'à 1000 mm) Ø 133 (> 1000 mm)
75 mm	75 mm	75 mm

*En la Serie Pesada, en función de las necesidades, se montan tambores motrices y tensores de otros diámetros, y la altura de la celosía se puede aumentar en función de la necesidad de luz entre apoyos. Construimos también transportadores ripables, extensibles y otras aplicaciones especiales.

*In the Heavy Duty Range, according to our customers needs, we can assemble driving and tensor drums in other diameters and the height of the frame can be increased according to the space required between supports.. We also build shiftable conveyors, extendable conveyors and other special applications

* Dans la série lourde, selon les besoins, est montée tambours moteurs et tenseur d'autres diamètres, et la hauteur de la jalousie peut être augmentée selon les besoins de lumière entre les appuis.



**Detectores
Separadores
Detectors
Separators
DéTECTEURS
SéPARATEURS**

7

MD

Detector de Metales Metal Detector Détecteur de Métaux

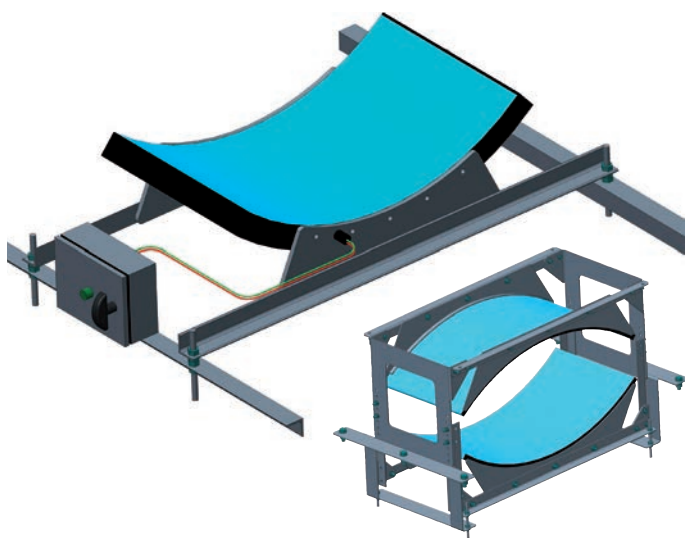

Modelo Model Modèle	Anchos de detección Detection widths largueurs de détection (mm)
MD-650	650
MD-800	800
MD-1000	1000
MD-1200	1200

ALIMENTACIÓN POWER SUPPLY ALIMENTATION	220 V/ 50 HZ
CONSUMO CONSUMPTION COURANT	36 mA.
TEMPERATURA DE TRABAJO OPERATING TEMPERATURE TEMP. E DE FONCTIONNEMENT	-20 + 50 °C
PROTECCIÓN PROTECTION PROTECTION	IP-67
ALTURA MÁXIMA DE DETECCIÓN MAXIMUM DETECTION HEIGHT HAUTEUR MAX. DE DÉTECTION	300 mm

Modelo/Model/Modèle	A (mm)	B (mm)	C (mm)	D (mm)	Peso/Weight/Poids (kg)	
MD-650	700	400	470	580	10	20
MD-800	880	400	470	630	11	22
MD-1000	1090	400	470	730	12	24
MD-1200	1290	400	470	830	13	26

Separadores Magnéticos Magnetic Separator Séparateurs Magnétiques

MS

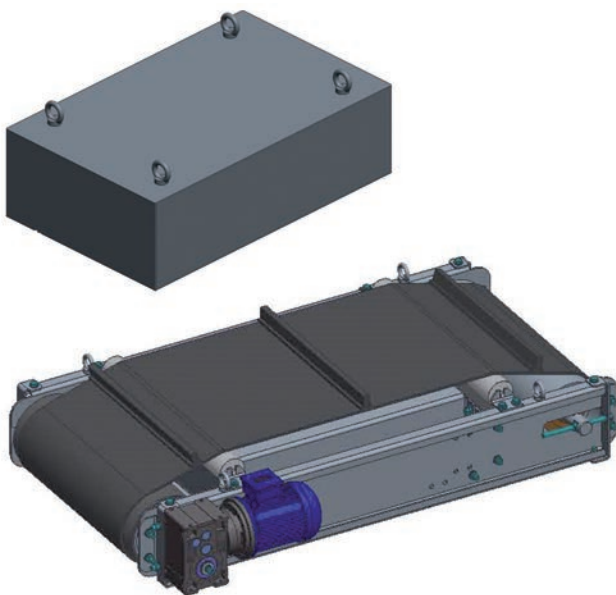

Modelo Model Modèle	Ancho Width Largeur (mm)	Altura máx. de trabajo Max. height of work Hauteur max. de travail (mm)	Potencia magnética Magnetic power Puissance magnétique	Magnetismo Magnetism Magnétisme	Peso Weight Poids (kg)
MSM-500	500	200	500 Gauss (400 mm)	Imanes permanentes Permanent magnets Aimants permanents	375
MSM-650	650	200			465
MSM-800	800	300			555
MSM-1000	1000	300			675
MSM-1200	1200	300			795

Modelo Model Modèle	Ancho Width Largeur (mm)	Potencia banda Belt power Puissance bande (kw)	Placa magnética Magnetic plate Plaque magnétique	Potencia magnética Magnetic power Puissance magnétique	Peso Weight Poids (kg)
MSA-500	500	1,1	MS-500		750
MSA-650	650	1,1	MS-650	500	845
MSA-800	800	1,1	MS-800	Gauss	945
MSA-1000	1000	1,5	MS-1000	(400 mm)	1095
MSA-1200	1200	1,5	MS-1200		1225



**Recambios
Accesorios
Parts
Accessories
Rechanges
Accessoires**

8

RB

Romperocas Rock Breaker Brise Roche



Brazo / Arm / Bras

Martillo / Hammer / Marteau

Modelo Model Modèle	Peso Excavadora Excavator Weighth Poids Pelle (kg)	Potencia Power Puissance (Kw)	Peso Weighth Poids (kg)	Energía Energy Energie (Jul)	Puntero Drill Bit Pointe Ø
RB-200	3500	15	215	480	60
RB-400	5600	22	415	975	75
RB-600	9000	30	590	1490	85

Básculas para Transportadores
Scales for Conveyors
Balances pour Convoyeurs

SC

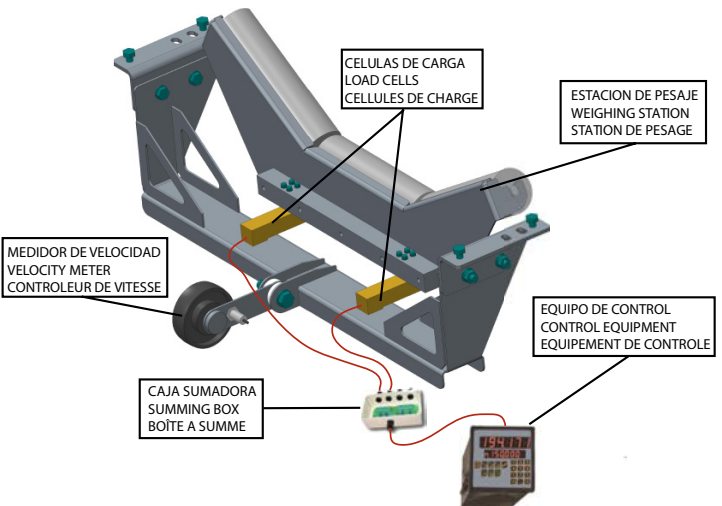
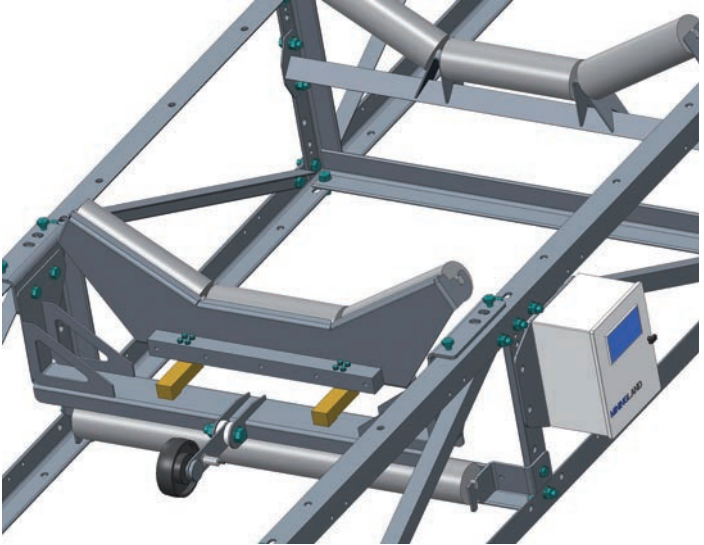

Recambios / Accesorios
Parts / Accessories
Rechanges / Accessoires

Cucharones

Buckets

Godets



**Recambios / Accesorios
Parts / Accessories
Rechanges / Accessoires**

Rodillos / Rollers / Rouleaux

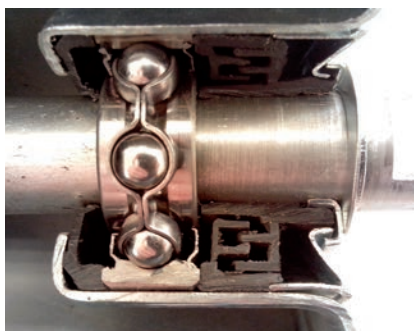

Bandas / Belts / Bandes



Recambios / Accesorios
Parts / Accessories
Rechanges / Accessoires



Fundición
Casting
Fondeire

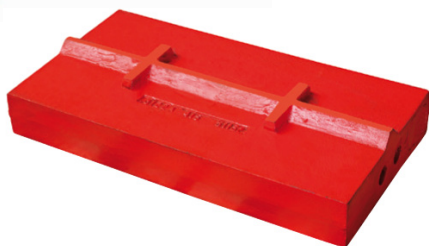

**Recambios / Accesorios
Parts / Accessories
Rechanges / Accessoires**

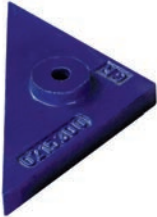

Miningland Machinery, s.l.

Pol. Ind. Agustinos, Calle F, 7-E
31013 Pamplona-Navarra-España

Tel.: +34 948 064 063

Fax: +34 948 104 262

info@miningland.es

www.miningland.es

