

# 600 CRAWLER SERIES

TELESCOPIC BOOM LIFTS



## Performance

Platform Height		
600SC	59 ft 5 in.	18.11 m
660SJC	65 ft 7 in.	19.99 m
Horizontal Outreach		
600SC	50 ft 3 in.	15.32 m
660SJC	57 ft 0.6 in.	17.39 m
Swing	360° Continuous	
Platform Capacity		
600SC Restricted/Unrestricted	1,000/600 lb	454/272 kg
660SJC Restricted/Unrestricted	750/550 lb	340/249 kg
Platform Rotator		
600SC	160° Hydraulic	
660SJC	180° Hydraulic	
Jib Range of Articulation		
660SJC Only	132°	+71, -61
Weight <sup>1</sup>		
600SC	25,942 lb	11,767 kg
660SJC	29,339 lb	13,308 kg
Max. Ground Bearing Pressure		
600SC	5.45 psi	0.383 kg/cm <sup>2</sup>
660SJC	6.5 psi	0.457 kg/cm <sup>2</sup>
Drive Speed	1.6 mph	2.6 kmph
Gradeability	55%	
Turning Radius	Zero	
Type of Tracks	Steel	
Tracks Width	1 ft 7.7 in.	0.5 m

1. Certain options or country standards will increase weight.

## Standard Specifications

### Engine

Diesel Engine, Deutz TD2.9L4 Tier 4 Final	67 hp	50 kW
Fuel Tank Capacity	31 gal	117 L
Auxiliary Power	12V DC	

### Hydraulic Reservoir

Capacity	34 gal	129 L
----------	--------	-------

## Standard Features

- 36 x 96 in. (0.91 x 2.44 m) Platform
- Customized Crawler Chassis
- Steel Link Tracks
- Inward Swing Gate
- 180 Degree Hydraulic Platform Rotator<sup>1</sup>
- Platform Console Machine Status
- Light Panel<sup>2</sup>
- 110V-AC Receptacle in the Platform
- 5-degree Tilt Alarm/Indicator Light
- Swing-out Engine Module
- Gull-wing Engine Hood
- 12V-DC Auxiliary Power
- Proportional Controls
- Lifting/Tie Down Lugs
- Hourmeter
- Bolt-on Lifting Lugs
- Horn
- Motion Alarm
- Interactive Display at Ground Controls
- Control ADE System
- SkyGuard<sup>®</sup>



## Accessories & Options

- 36 x 72 in. (0.91 x 1.83 m) Platform
- Platform Work Lights
- Bolt-on Aluminum Mesh to Top Rail
- Light Package
- Flashing Amber Beacon
- Cold Weather Kit<sup>3</sup>
- Hostile Environment Kit<sup>4</sup>
- Arctic Package<sup>5</sup>
- Inward Self-closing Swing Gate
- Fall Arrest Platform 36 x 72 in. (0.91 x 1.83 m)
- 1/2 in. Air Line to Platform
- Soft Touch System
- AC Generator
- Special Hydraulic Oils (consult factory)
- Spark Arresting Muffler
- Operator Tool Tray
- Accessory Packages
  - SkyPower<sup>®</sup> Package
  - SkyWelder<sup>®</sup> Package
  - SkyGlazier<sup>®</sup> Package
  - Nite Bright<sup>®</sup> Package

1. 160 degrees on 600SC.

2. Provides indicator lights at platform control console for system distress, low fuel, 5-degree tilt light and footswitch status.

3. Includes engine block heater, battery heater and oil tank heater.

4. Includes console cover, boom wipers and cylinder bellows.

5. Includes arctic hydraulic hoses (drive and steer only) and main boom cable, arctic hydraulic oil, extreme cold engine oil, anti-freeze, fuel conditioner, engine block heater, battery blanket, glow plugs, hydraulic tank heater, and oversized footswitch.

# 600 CRAWLER SERIES

TELESCOPIC BOOM LIFTS



## Dimensions

All dimensions are approximate.

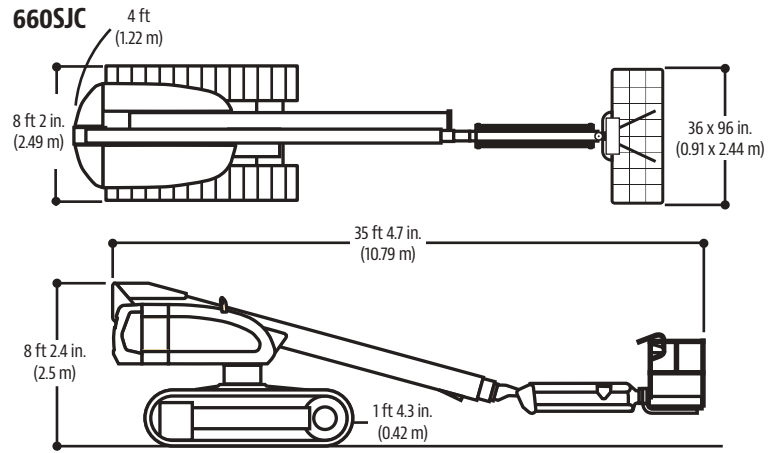
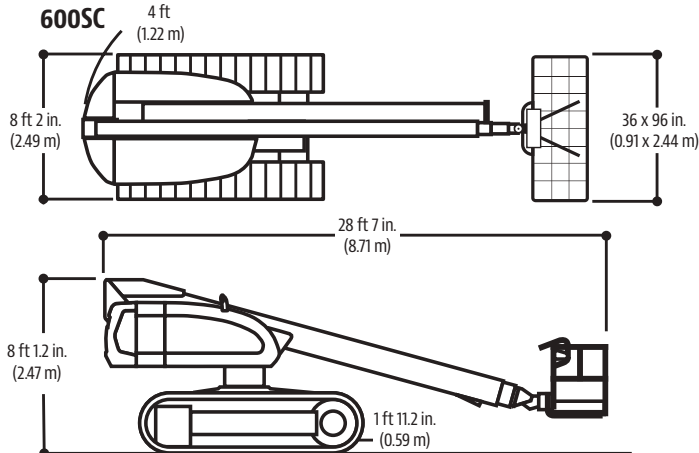

## Reach Diagrams

### 600SC

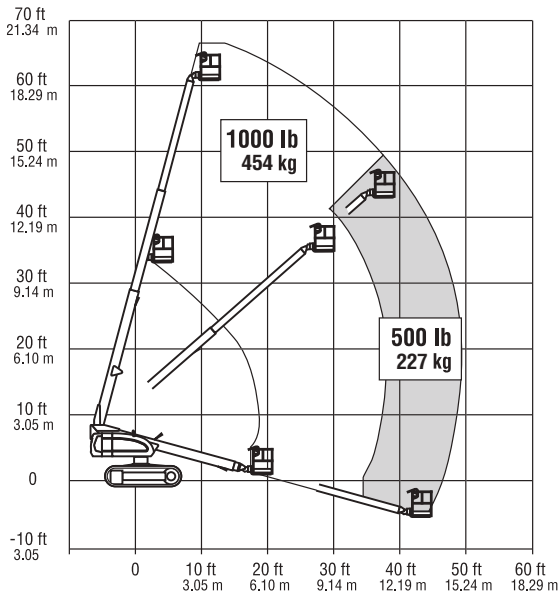

### 660SJC

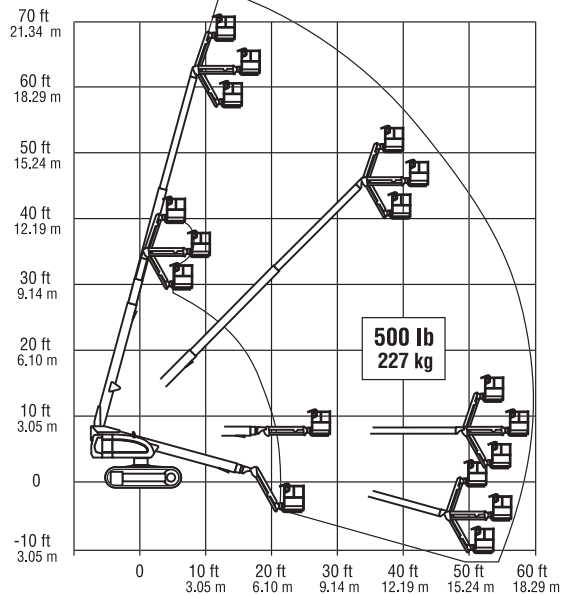

## The JLG "1 & 5" Warranty

We provide coverage for one (1) full year, and cover all specified major structural components for five (5) years. Due to continuous product improvements, we reserve the right to make specification and/or equipment changes without prior notification. This machine meets or exceeds applicable ANSI and CSA requirements based on machine configuration as originally manufactured for intended applications. Please reference the serial number plate on the machine for additional information.

Part No.: 3131016  
R1219\_A92.20  
Printed in USA



**JLG Industries, Inc.**  
1 JLG Drive  
McConnellsburg, PA 17233-9533  
Telephone 717-485-5161  
Toll-free in US 877-JLG-LIFT  
Fax 717-485-6417  
[www.jlg.com](http://www.jlg.com)

**An Oshkosh Corporation Company**