

FitStay 5

Unlock the full potential of your hotel with the FitStay 5 Outdoor Fitness Park. Designed to inspire and motivate, this exceptional outdoor fitness facility will leave a lasting impression on your guests. Featuring a wide array of top-of-the-line exercise equipment, FitStay 5 offers a one-of-a-kind fitness experience amidst the natural beauty of your hotel surroundings.

Attributes

Product code	1-3-239
Certificate	EN 16630
Age group	14 + years
Designed for	Hotels
Capacity	22 people
Fall height	1.6 m

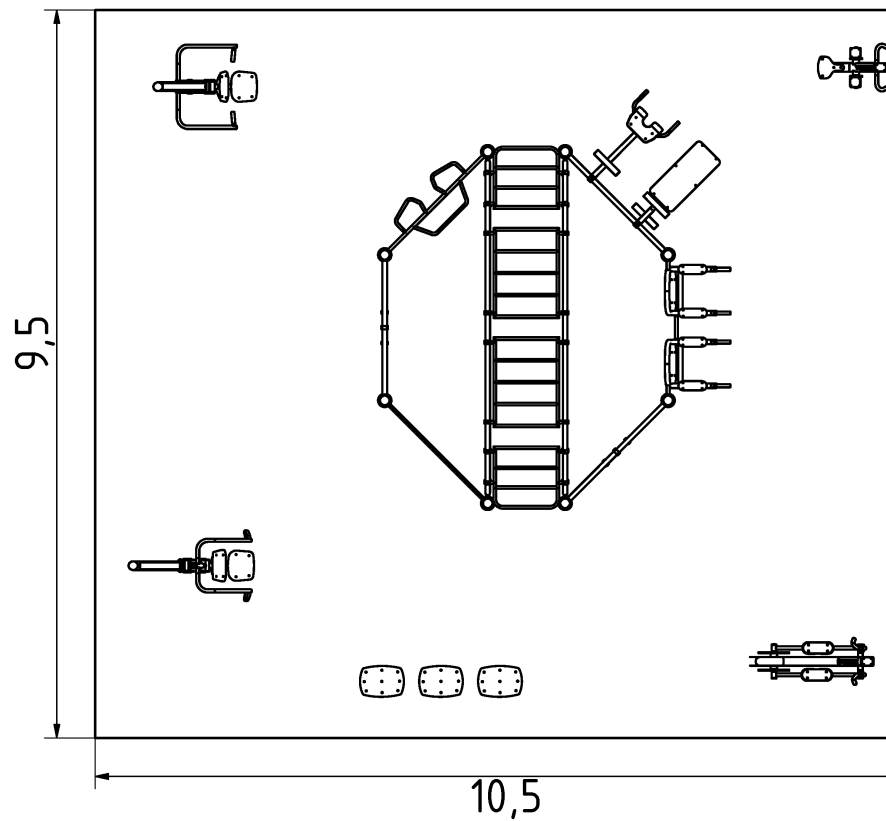

Technical specification

Anchoring option
 Net weight
 Material
 Anti-corrosion possibility
 Total Area
 Color options
 For more color options, discuss with your sales representative.

In-ground or surface
 1084 kg
 S235
 Galvanized or EPD
 100 m²



Warranty

Structure
 Steel
 Paint
 Plastic
 Rubber
 Moving parts
 Detailed information in the warranty document

25-15 years
 5-10 years
 2 years
 5-10 years
 1-3 years
 2 years