



INDEX	PAGE(S)
<u>The MultiTek Cart</u>	238 - 241
Preconfigured Models . . . . .	242 - 250
Accessories . . . . .	251 - 253

## MULTITEK CART

The MultiTek Cart is an ergonomic and multifunctional cart. In an innovative leap forward from standard cart solutions, not only does it transport tools, parts and other items, it also functions as a small portable workstation.

Many configurations are possible, ranging from minimalist to fully equipped. A wide range of accessories can be installed, so you can keep your tools organized and always on hand in your own personalized and mobile workstation.

Cart models with drawers include a lock-in mechanism and those with a cover have a standard lock. PVC liners are also available as optional accessories.

Heavy-duty and maneuverable, the MultiTek Cart is the ideal companion to help you perform your daily tasks.

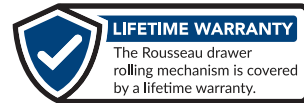

THE ROUSSEAU DIFFERENCE

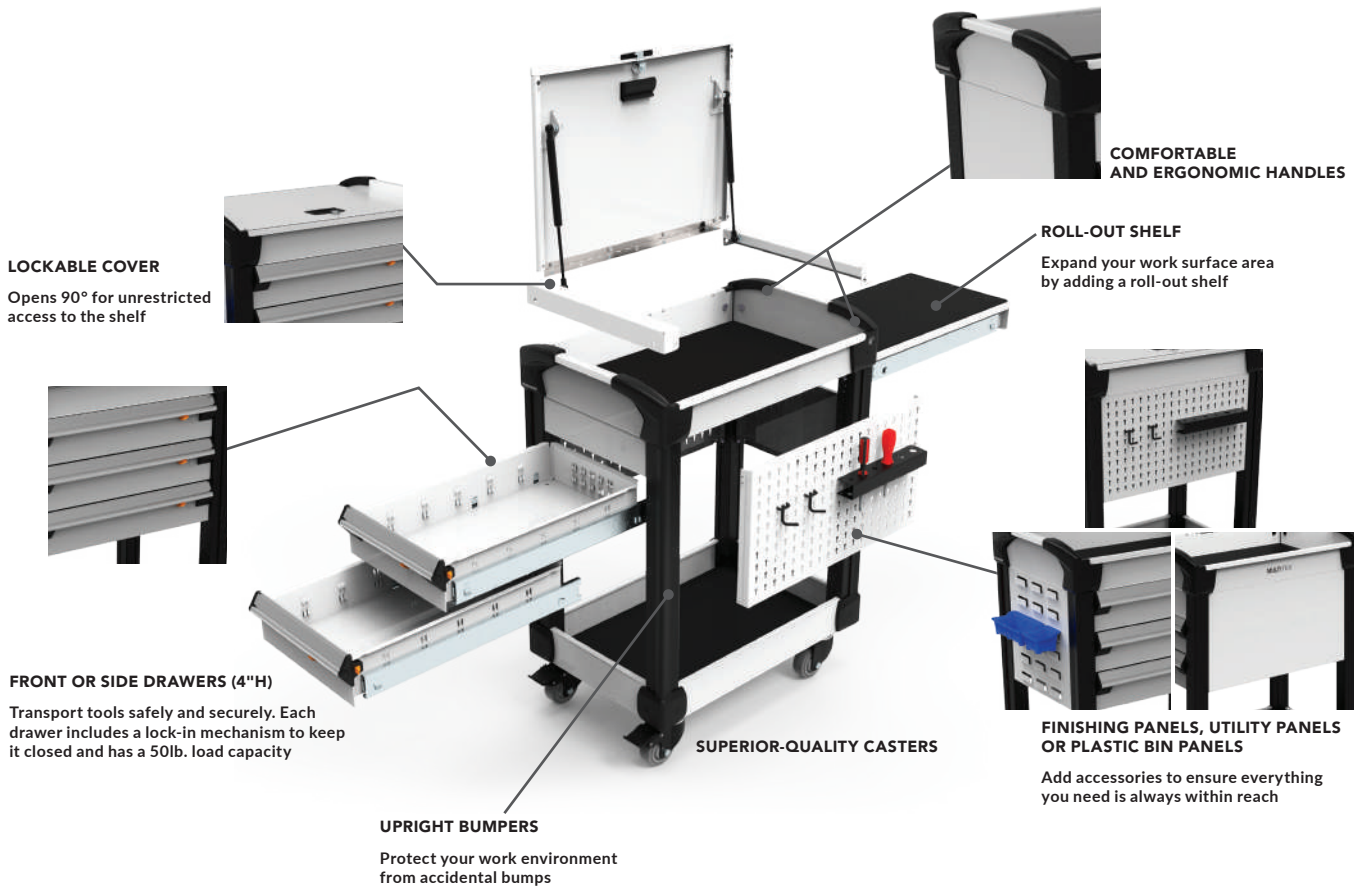

GENERAL DIMENSIONS

CARTS WITH 3" H CASTERS

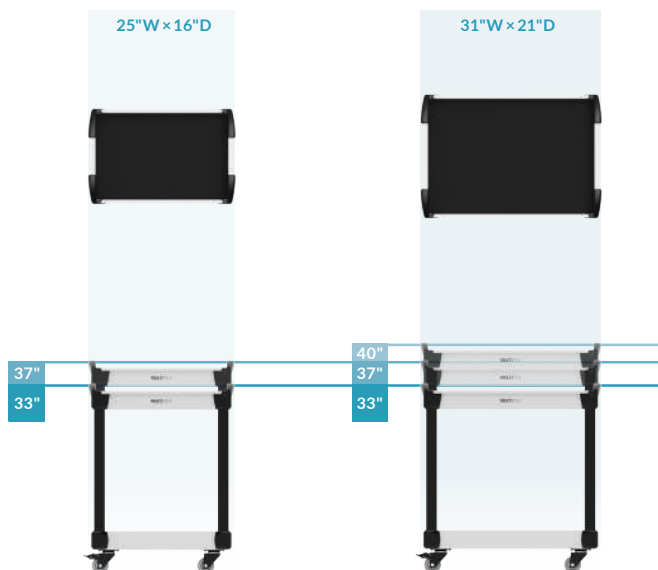

CARTS WITH 5" H CASTERS

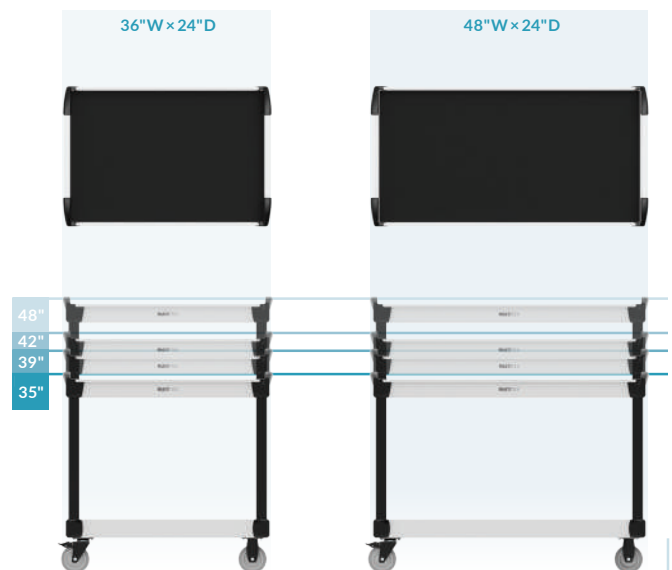

SHELF AND INTERMEDIATE SHELF DIMENSIONS

25"W x 16"D CART

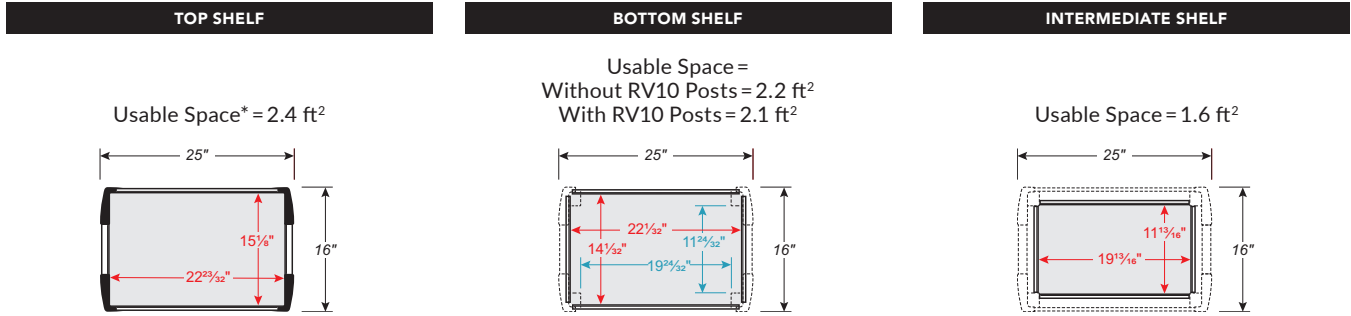

31"W x 21"D CART

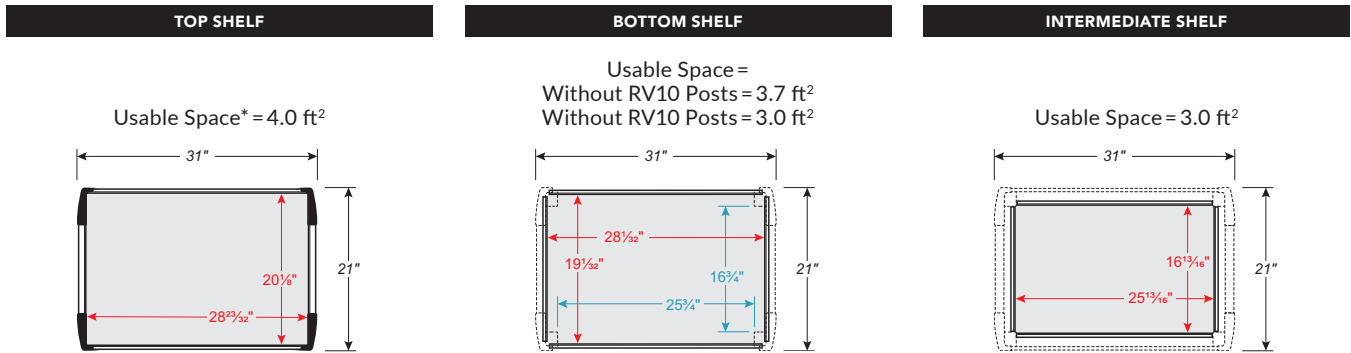

36"W x 24"D CART

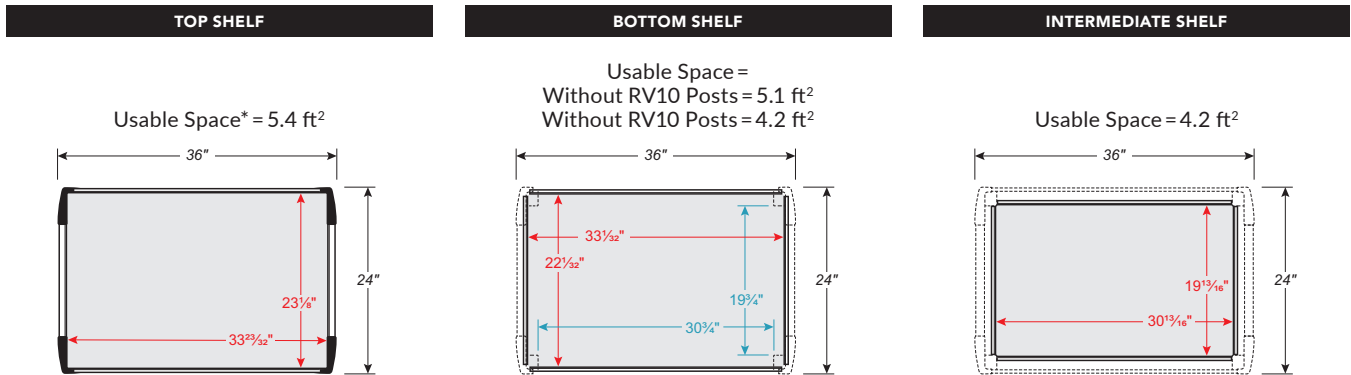

48"W x 24"D CART

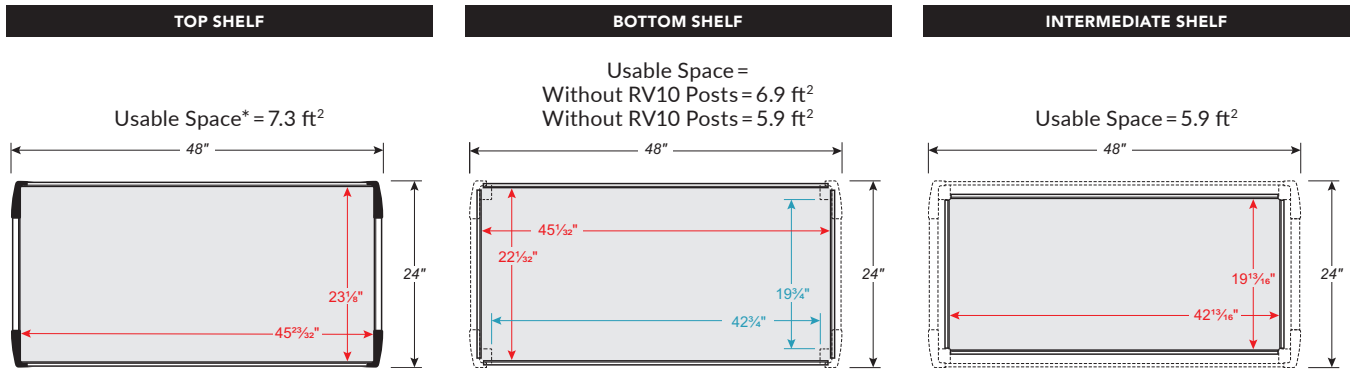

NOTE: \* The clearance corresponds to the space between the plastic end caps, which reduces the usable space.

## DRAWER AND ROLL-OUT SHELF DIMENSIONS

### 25"W x 16"D CART

**SIDE DRAWER**

Usable Space = 1.2 ft<sup>2</sup>

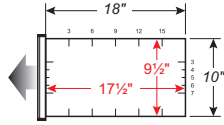

**FRONT DRAWER**

Usable Space = 1.4 ft<sup>2</sup>

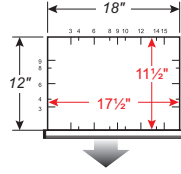

**SIDE ROLL-OUT SHELF**

Usable Space = 1.4 ft<sup>2</sup>

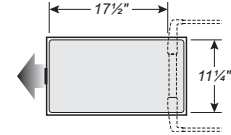

### 31"W x 21"D CART

**SIDE DRAWER**

Usable Space = 1.8 ft<sup>2</sup>

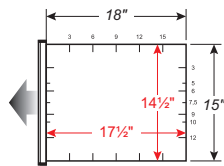

**SIDE HALF-DRAWER (BACK-TO-BACK DRAWERS)**

Usable Space = 1.2 ft<sup>2</sup>

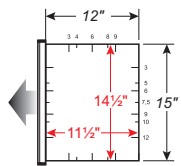

**FRONT DRAWER**

Usable Space = 2.9 ft<sup>2</sup>

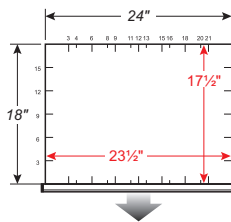

**SIDE ROLL-OUT SHELF**

Usable Space = 2.1 ft<sup>2</sup>

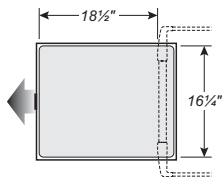

**SIDE ROLL-OUT HALF-SHELF (BACK-TO-BACK ROLL-OUT SHELVES)**

Usable Space = 1.3 ft<sup>2</sup>

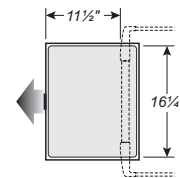

# PRECONFIGURED MODELS

## DRAWER COMPARTMENTS

SIDE DRAWERS FOR 25"W x 16"D CART

PARTITIONS AND DIVIDERS				GROOVE TRAYS *	
ROGBS-A010004 2 COMPARTMENTS	ROGBS-A010204 4 COMPARTMENTS	ROGBS-A010404 6 COMPARTMENTS	ROGBS-A011004 12 COMPARTMENTS	ROGBS-T01004 10 GROOVE TRAYS	ROGBS-T01204 12 GROOVE TRAYS
PLASTIC BINS			FOAM		
ROGBS-E01204 12 BINS	ROGBS-E01404 14 BINS	ROGBS-E01504 15 BINS	ROGBS-J0104 PROTECTIVE FOAM	ROGBS-J0204 TOOL FOAM	ROGBS-J0304 COLLET FOAM



FRONT DRAWERS FOR 25"W x 16"D CART

PARTITIONS AND DIVIDERS				GROOVE TRAYS *	
ROGBF-A020004 3 COMPARTMENTS	ROGBF-A010204 4 COMPARTMENTS	ROGBF-A020304 6 COMPARTMENTS	ROGBF-A051204 18 COMPARTMENTS	ROGBF-T00804 8 GROOVE TRAYS	ROGBF-T01004 10 GROOVE TRAYS
PLASTIC BINS			FOAM		
ROGBF-E00604 6 BINS	ROGBF-E01204 12 BINS	ROGBF-E01304 13 BINS	ROGBF-J0104 PROTECTIVE FOAM	ROGBF-J0204 TOOL FOAM	ROGBF-J0304 COLLET FOAM



NOTES: \* Two dividers included with each groove tray.  
 Preconfigured drawer layouts can be added to the MultiTek Cart preconfigured, [see pages 245-246](#).  
 Preconfigured drawer layouts include subdividing accessories only (not the drawer).

## SIDE HALF-DRAWERS FOR 31"W x 21"D CART

PARTITIONS AND DIVIDERS				GROOVE TRAYS*	
RONHB-A010004 2 COMPARTMENTS	RONHB-A010204 4 COMPARTMENTS	RONHB-A020304 6 COMPARTMENTS	RONHB-A020604 9 COMPARTMENTS	RONHB-T00604 6 GROOVE TRAYS	RONHB-T00804 8 GROOVE TRAYS
PLASTIC BINS			FOAM		
RONHB-E01204 12 BINS	RONHB-E01304 13 BINS	RONHB-E02004 20 BINS	RONHB-J0104 PROTECTIVE FOAM	RONHB-J0204 TOOL FOAM	RONHB-J0304 COLLET FOAM

**Sold without cut-outs**

## SIDE DRAWERS FOR 31"W x 21"D CART

PARTITIONS AND DIVIDERS				GROOVE TRAYS*	
RONHS-A010004 2 COMPARTMENTS	RONHS-A010204 4 COMPARTMENTS	RONHS-A010404 6 COMPARTMENTS	RONHS-A042504 30 COMPARTMENTS	RONHS-T00804 8 GROOVE TRAYS	RONHS-T01004 10 GROOVE TRAYS
PLASTIC BINS			FOAM		
RONHS-E01204 12 BINS	RONHS-E01804 18 BINS	RONHS-E02104 21 BINS	RONHS-J0104 PROTECTIVE FOAM	RONHS-J0204 TOOL FOAM	RONHS-J0304 TOOL FOAM

**Sold without cut-outs**

NOTES: \* Two dividers included with each groove tray.  
 Preconfigured drawer layouts can be added to the MultiTek Cart preconfigured, [see pages 247-248](#).  
 Preconfigured drawer layouts include subdividing accessories only (not the drawer).

# PRECONFIGURED MODELS

## FRONT DRAWERS FOR 31"W x 21"D CART

PARTITIONS AND DIVIDERS				GROOVE TRAYS*	
RONHF-A010204 4 COMPARTMENTS	RONHF-A030404 8 COMPARTMENTS	RONHF-A030804 12 COMPARTMENTS	RONHF-A074004 48 COMPARTMENTS	RONHF-T01204 12 GROOVE TRAYS	RONHF-T01404 14 GROOVE TRAYS
PLASTIC BINS			FOAM		
RONHF-E02704 27 BINS	RONHF-E02804 28 BINS	RONHF-E03404 34 BINS	RONHF-J0104 PROTECTIVE FOAM	RONHF-J0204 TOOL FOAM	RONHF-J0304 COLLET FOAM

**Sold without cut-outs**

NOTES: \* Two dividers included with each groove tray.  
 Preconfigured drawer layouts can be added to the MultiTek Cart preconfigured, [see pages 247-248](#).  
 Preconfigured drawer layouts include subdividing accessories only (not the drawer).



## 25"W x 16"D CARTS

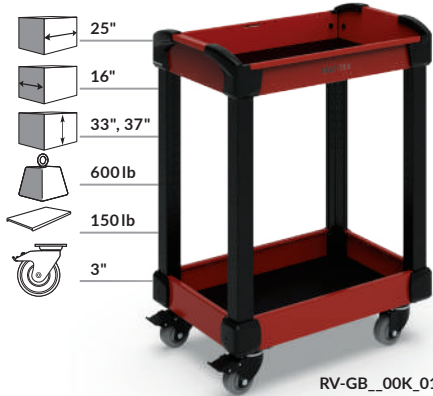

The 25"W x 16"D MultiTek Cart is compact and easy to maneuver. It offers plenty of storage space and multiple configurations

- Total load capacity: 600lb.
- Add intermediate shelves to transport more items
- The top, intermediate and bottom shelves each have a 150lb. load capacity
- The 4"H front and side drawers have a 50lb. load capacity and include a lock-in mechanism to prevent the drawers from opening by themselves
- The side roll-out shelf is lined with a rubber mat, has a 15lb. total load capacity and provides an extra work surface
- The cover features strategically placed gas springs to allow access to the top shelf when open. It is also equipped with a lock to secure the contents when closed
- For available accessories, [see pages 251-253](#)

**SPECIFY THE HEIGHT, MAT AND LOCK REQUIRED**

Height: 33" = 33    37" = 37

Rubber Mat on each shelf: With = 0    Whitout = 1

Drawer Lock = L3

RV-GB\_\_A1F\_02\_\_B

**IMPORTANT**

All models with shelves only are sold non-assembled.

**FRONT DRAWER**



PRODUCT NO.  
RV-GB\_\_A1F\_04\_\_B

**2 FRONT DRAWERS**



PRODUCT NO.  
RV-GB\_\_A2F\_04\_\_B

**FRONT DRAWER, SIDE ROLL-OUT SHELF**



PRODUCT NO.  
RV-GB\_\_A1F\_02\_\_B

**2 FRONT DRAWERS, SIDE ROLL-OUT SHELF**



PRODUCT NO.  
RV-GB\_\_A2F\_02\_\_B

**FRONT DRAWER, COVER, UTILITY PANEL**



PRODUCT NO.  
RV-GB\_\_A1UC10\_\_B<sup>1</sup>

**2 FRONT DRAWERS, COVER, UTILITY PANEL, UPRIGHT BUMPERS**



PRODUCT NO.  
RV-GB\_\_A2UC12\_\_B<sup>1</sup>

NOTE: <sup>1</sup>For this model without a rubber mat replace the letter C with L.

# PRECONFIGURED MODELS

SIDE DRAWER



PRODUCT NO.  
RV-GB\_S1F\_04\_B

2 SIDE DRAWERS



PRODUCT NO.  
RV-GB\_S2F\_04\_B

2 SIDE DRAWERS,  
SIDE ROLL-OUT SHELF



PRODUCT NO.  
RV-GB\_S2F\_06\_B

2 SIDE DRAWERS,  
SIDE ROLL-OUT SHELF, COVER,  
UTILITY PANELS, UPRIGHT BUMPERS



PRODUCT NO.  
RV-GB\_S2X\_02\_B

SIDE DRAWER, SIDE ROLL-OUT SHELF



PRODUCT NO.  
RV-GB\_S1F\_06\_B

SIDE ROLL-OUT SHELF



PRODUCT NO.  
RV-GB\_00F\_01



## 31"W x 21"D CARTS

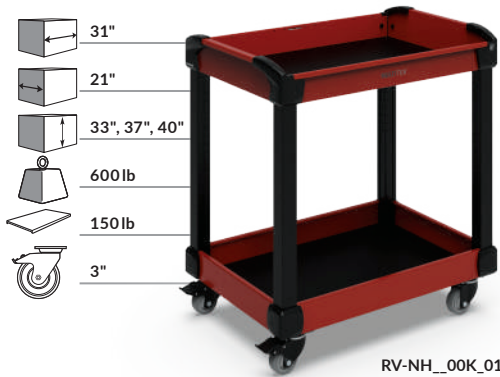

The 31"W x 21"D cart offers plenty of storage space and multiple configurations. With this size, you can have roll-out shelves or drawers on both sides of the cart

- Total load capacity: 600lb.
- Add intermediate shelves to transport more items
- The top, intermediate and bottom shelves each have a 150lb. load capacity
- The 4"H front and side drawers have a 50lb. load capacity and include a lock-in mechanism to prevent the drawers from opening by themselves
- The side roll-out shelf is lined with a rubber mat, has a 15lb. total load capacity and provides an extra work surface
- The cover features strategically placed gas springs to allow access to the top shelf when open. It is also equipped with a lock to secure the contents when closed
- For available accessories, [see pages 251-253](#)

**SPECIFY THE HEIGHT, MAT AND LOCK REQUIRED**

Height:  
33" = 33    37" = 37  
40" = 40

Rubber Mat on each shelf:  
With = 0    Whitout = 1

Drawer Lock = L3

RV-NH\_\_A1F\_02\_\_B

**IMPORTANT**  
All models with shelves only are sold non-assembled.

### SIDE DRAWER



PRODUCT NO.  
RV-NH\_\_S1F\_04\_\_B

### 2 SIDE DRAWERS



PRODUCT NO.  
RV-NH\_\_S2F\_04\_\_B

### 3 SIDE DRAWERS



PRODUCT NO.  
RV-NH\_\_S3F\_04\_\_B

### 3 FRONT DRAWERS, COVER, PLASTIC BIN PANEL, UPRIGHT BUMPERS



PRODUCT NO.  
RV-NH\_\_A3X\_02\_\_B

### 3 FRONT DRAWERS, COVER, UTILITY PANEL, UPRIGHT BUMPERS



PRODUCT NO.  
RV-NH\_\_A3UC16\_\_B<sup>1</sup>

### SIDE ROLL-OUT SHELF



PRODUCT NO.  
RV-NH\_\_00F\_01

NOTE: <sup>1</sup>For this model without a rubber mat replace the letter C with L.

# PRECONFIGURED MODELS

FRONT DRAWER,  
2 SIDE ROLL-OUT HALF-SHELVES



PRODUCT NO.  
RV-NH\_A1F\_06\_B

2 FRONT DRAWERS,  
2 SIDE ROLL-OUT HALF-SHELVES



PRODUCT NO.  
RV-NH\_A2F\_06\_B

2 FRONT DRAWERS,  
2 SIDE ROLL-OUT HALF-SHELVES,  
COVER, UTILITY PANEL



PRODUCT NO.  
RV-NH\_A2UC06\_B<sup>1</sup>

2 SIDE HALF-DRAWERS



PRODUCT NO.  
RV-NH\_B2F\_02\_B

FRONT DRAWER,  
2 SIDE HALF-DRAWERS



PRODUCT NO.  
RV-NH\_M3F\_02\_B

2 SIDE ROLL-OUT HALF-SHELVES



PRODUCT NO.  
RV-NH\_00F\_02

3 SHELVES



PRODUCT NO.  
RV-NH\_00K\_07

3 SHELVES, UTILITY PANELS



PRODUCT NO.  
RV-NH\_00U\_07

3 SHELVES WITH TOOL FOAM<sup>2</sup>,  
UTILITY PANEL, LONG TOOL HOLDER



PRODUCT NO.  
RV-NH\_00U210<sup>2</sup>

NOTE: <sup>1</sup>For this model without a rubber mat replace the letter C with L. <sup>2</sup>Sold without cut-outs.

## 36"W x 24"D CARTS

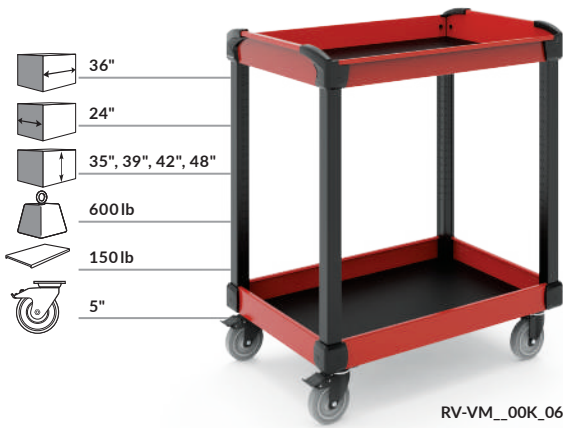

The 36"W x 24"D MultiTek Cart is ideal for transporting large parts. You will find it quickly becomes indispensable in your department.

- Total load capacity: 600lb.
- Add intermediate shelves to transport more items
- The top, intermediate and bottom shelves each have a 150lb. load capacity
- For available accessories, [see pages 251-253](#)

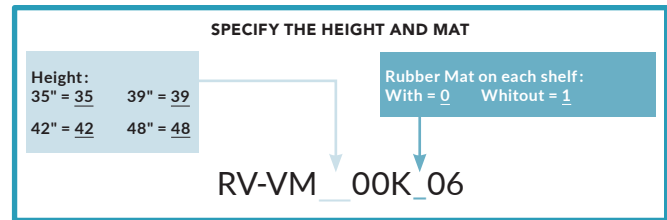

**IMPORTANT**

All models with shelves only are sold non-assembled.

### 2 SHELVES



PRODUCT NO.  
RV-VM\_00K\_06

### 3 SHELVES



PRODUCT NO.  
RV-VM\_00K\_08

### 4 SHELVES



PRODUCT NO.  
RV-VM\_00K\_09

### 2 SHELVES, UTILITY PANELS



PRODUCT NO.  
RV-VM\_00U\_06

### 3 SHELVES, UTILITY PANELS



PRODUCT NO.  
RV-VM\_00U\_08

### 4 SHELVES, UTILITY PANELS



PRODUCT NO.  
RV-VM\_00U\_09

# PRECONFIGURED MODELS

## 48"W x 24"D CARTS

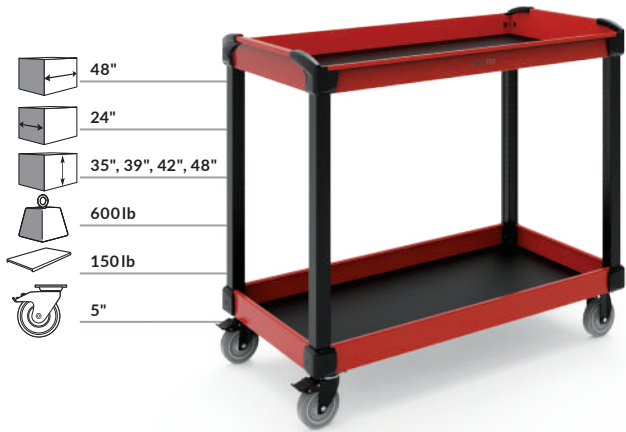

RV-ZM\_\_00K\_06

The 48"W x 24"D MultiTek Cart is ideal for transporting large parts. You will find it quickly becomes indispensable in your department.

- Total load capacity: 600lb.
- Add intermediate shelves to transport more items
- The top, intermediate and bottom shelves each have a 150lb. load capacity
- For available accessories, [see pages 251-253](#)

**SPECIFY THE HEIGHT AND MAT**

Height: 35" = <u>35</u>	39" = <u>39</u>	Rubber Mat on each shelf: With = <u>0</u> Whitout = <u>1</u>
42" = <u>42</u>	48" = <u>48</u>	

RV-ZM\_\_00K\_06

**IMPORTANT**

All models with shelves only are sold non-assembled.

### 2 SHELVES



PRODUCT NO.  
RV-ZM\_\_00K\_06

### 3 SHELVES



PRODUCT NO.  
RV-ZM\_\_00K\_08

### 4 SHELVES



PRODUCT NO.  
RV-ZM\_\_00K\_09

### 2 SHELVES, UTILITY PANELS



PRODUCT NO.  
RV-ZM\_\_00U\_06

### 3 SHELVES, UTILITY PANELS



PRODUCT NO.  
RV-ZM\_\_00U\_08

### 4 SHELVES, UTILITY PANELS



PRODUCT NO.  
RV-ZM\_\_00U\_09

## ACCESSORIES

### INTERMEDIATE SHELF

RV25



- Load capacity: 150lb. per shelf, 600lb. max. per cart
- One or two shelves can be added to the cart
- Compatible with finishing panels, utility panels and plastic bin panels
- Thickness: 2"

PRODUCT NO.	W x D
RV25-2516	25" x 16"
RV25-3121	31" x 21"
RV25-3624	36" x 24"
RV25-4824	48" x 24"

### NON-SLIP PVC LINER FOR SHELF

RV44 / RV74

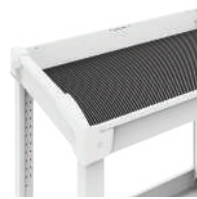

- Protects items stored on a shelf
- One piece of 1/16"-thick
- To order a PVC Liner for a top or bottom shelf: [RV44](#)
- To order a PVC Liner for an intermediate shelf: [RV74](#)

PRODUCT NO.	W x D
RV_-2516-01	25" x 16"
RV_-3121-01	31" x 21"
RV_-3624-01	36" x 24"
RV_-4824-01	48" x 24"

### TOOL FOAM FOR SHELF

RV47 / RV77

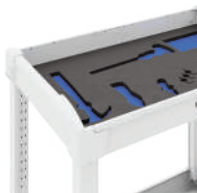

- Oil resistant and non-absorbent
- One piece of 1/4"-thick blue foam
- One piece of 1/2"-thick self-adhesive black foam
- To order tool foam for a top or bottom shelf: [RV47](#)
- To order tool foam for an intermediate shelf: [RV77](#)

PRODUCT NO.	W x D
RV_-2516-01	25" x 16"
RV_-3121-01	31" x 21"
RV_-3624-01	36" x 24"
RV_-4824-01	48" x 24"



Sold without cut-outs

NOTE: Sold without cut-outs.

### PROTECTIVE FOAM FOR SHELF

RV46 / RV76



- Protects items stored on a shelf
- One piece of 1/4"-thick blue foam
- To order protective foam for a top or bottom shelf: [RV46](#)
- To order protective foam for an intermediate shelf: [RV76](#)

PRODUCT NO.	W x D
RV_-2516-01	25" x 16"
RV_-3121-01	31" x 21"
RV_-3624-01	36" x 24"
RV_-4824-01	48" x 24"

### UPRIGHT BUMPERS

RV63



- Kit of four protective bumpers
- Protects surrounding objects and the cart itself
- Made from soft PVC

PRODUCT NO.	MULTITEK CART (W x D)		
	25" x 16"	31" x 21"	36" x 24"
RV63-29	33"H	33"H	35"H
RV63-33	37"H	37"H	39"H
RV63-36		40"H	42"H
RV63-42			48"H

# ACCESSORIES

## LONG TOOL HOLDER

5S WM9Q



- For storing long tools, e.g., pry bars
- Easy to install
- Holds up to three long tools
- Space available for two smaller tools, e.g., screwdrivers
- Color: black

PRODUCT NO.	W x D x H
WM9Q-08	8" x 2" x 4"

NOTE: A range of holders, hooks and accessories are also available, see pages 262-264.

## HAMMER HOLDER

5S WM9R



- Holds up to 2 hammers
- Easy to install
- Designed for most plastic or rubber hammers and rubber mallets
- Color: black

PRODUCT NO.	W x D x H
WM9R-09	9 1/4" x 2 1/4" x 5 1/4"

NOTE: A range of holders, hooks and accessories are also available, see pages 262-264.

## DOCUMENT HOLDER

5S WM9S



- 10° angle on the front face compared to vertical
- Front face lower than back to assist in identifying documents
- Designed for both letter and legal sized papers

PRODUCT NO.	W x D x H
WM9S-01	12 1/4" x 3 3/4" x 10 1/2"

NOTE: A range of holders, hooks and accessories are also available, see pages 262-264.

## PVC DRAWER LINER

RV40

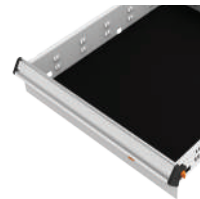

- Protects items stored in drawers
- 1/16" thick
- Can be used under partitions and dividers

PRODUCT NO.	DRAWER	CART WIDTH
RV40-1623-01S	Side	25"
RV40-2131-01S	Side	31"
RV40-2131-01S2	1/2 Side	31"
RV40-2516-01F	Front	25"
RV40-3121-01F	Front	31"

## PROTECTIVE FOAM FOR DRAWER

RV41



- Protects items stored in the drawer
- One piece of 1/4"-thick blue foam

PRODUCT NO.	DRAWER	CART WIDTH
RV41-1623-01S	Side	25"
RV41-2131-01S	Side	31"
RV41-2131-01S2	1/2 Side	31"
RV41-2516-01F	Front	25"
RV41-3121-01F	Front	31"

NOTE: Partitions and dividers cannot be installed in the same drawer as this foam.

## TOOL FOAM FOR DRAWER

RV42

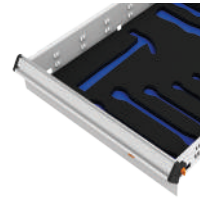

- Oil resistant and non-absorbent
- One piece of 1/4"-thick blue foam
- One piece of 1/2"-thick self-adhesive black foam

PRODUCT NO.	DRAWER	CART WIDTH
RV42-1623-01S	Side	25"
RV42-2131-01S	Side	31"
RV42-2131-01S2	1/2 Side	31"
RV42-2516-01F	Front	25"
RV42-3121-01F	Front	31"



## DRAWER LOCK

L3



- Drawer can be locked with the same key used for other products (cover for the cart's shelf, tool box, storage cabinet, etc.)
- Does not reduce the drawer's storage space
- Easy to retrofit
- To order: Add L3 to the product number



352

PRODUCT NO.

L3

## CASTERS

RV82 / RV83



- Available in two heights: 3" and 5"
- Sold in pairs
- Three types of casters available: fixed, swivel and swivel with brake
- Ultra-quiet casters
- Good chemical resistance

PRODUCT NO.	CASTER TYPE	HEIGHT	ACTUAL
RV82-01	Rigid	3"	4¼"
RV82-02	Swivel	3"	4¼"
RV82-03	Swivel with brake	3"	4¼"
RV83-01	Rigid	5"	6"
RV83-02	Swivel	5"	6"
RV83-03	Swivel with brake	5"	6"

NOTES: 25"W×16"D and 31"W×21"D MultiTek models include 3" wheels by default.  
36"W×24"D and 48"W×24"D MultiTek models include 5" wheels by default.

