

# HL5M Dri-Prime® Pumps

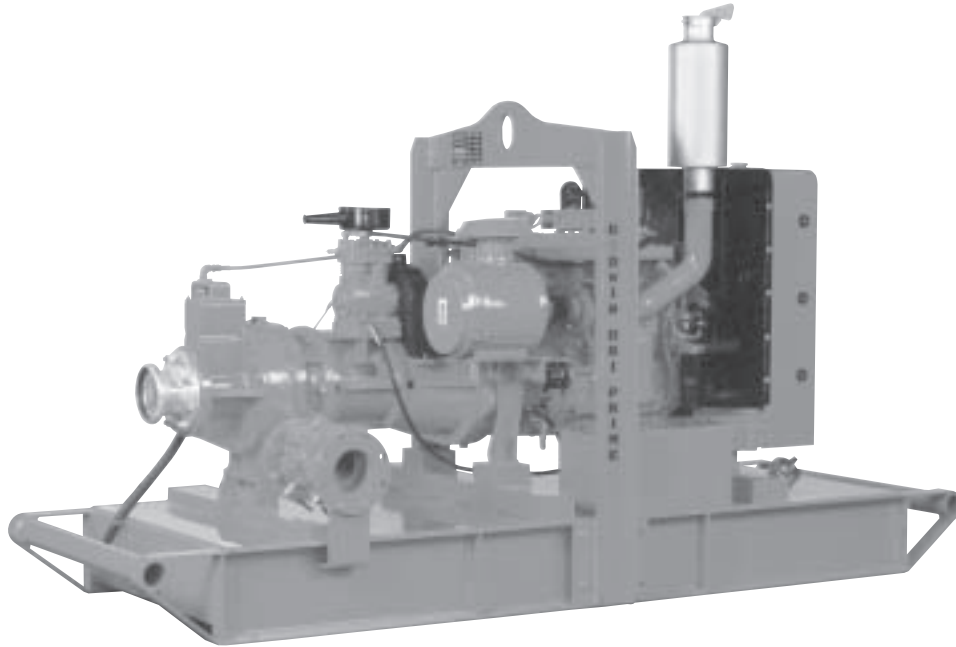

The HL5M automatic Godwin Dri-Prime 6" x 6" (150mm x 150mm) centrifugal pump is an extremely powerful yet compact high pressure pump with flow capabilities to 1450 gallons per minute (329 M<sup>3</sup>/hr.) and discharge heads to 500 feet (152.4 M). In addition, the HL5M features the unique Godwin high pressure oil bath mechanical seal design that allows for totally dry running for indefinite periods of time while automatically priming and repriming. Able to perform in the toughest conditions, the HL5M can pass a solid to 1-3/8" (35mm) in diameter, making it a high pressure trash pump as well as a superior dewatering pump. The powerful HL5M has already proven itself a pump of choice for mines, quarries, temporary fire pump systems and many other high pressure applications.

## Features

- Close coupled automatic priming 6" x 6" (150mm x 150mm) centrifugal pump mounted to a diesel engine. Also available in electric drive or as bare shaft pumpend.
- All chrome iron construction (cast iron or all stainless steel construction optional) with cast chromium steel impeller.
- Extensive application flexibility — will handle liquids with solids up to 1-3/8" (35mm) in diameter.
- Continuously operated "Godwin" venturi air ejector priming device featuring belt-driven air compressor requiring no form of periodic adjustment or control.
- Solids handling swing type Non Return Valve with renewable flexible rubber seat.
- Dry running, high pressure, oil bath mechanical seal with abrasion resistant solid silicon carbide interfaces.
- Compact unit mounted on a skid base or two wheeled highway trailer, both incorporating integral overnight running fuel tank.
- Simple maintenance — normally limited to checking engine and seal cavity oil levels.
- Standard engine, Caterpillar 3126TA. Available with a variety of engines including John Deere, Cummins and Deutz.
- Low profile side discharge for easy pipe connection.

SOLD BY



info@aquosis.com  
1.877.907.7852

# HL5M Performance Curve

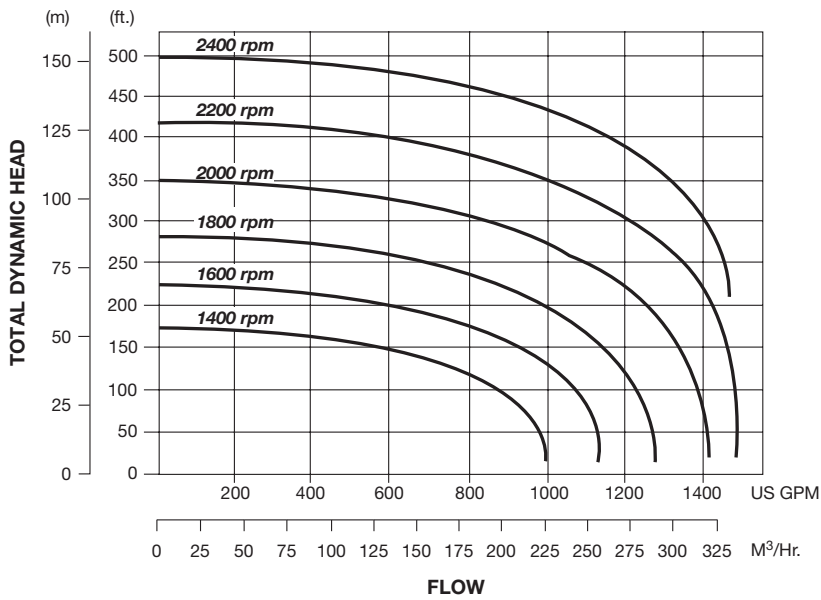

## Performance Table

**HL5M Diesel Set** — Caterpillar 3126TA, 220 hp (164 kw) @ 2400 rpm  
**Impeller Diameter** — 15-1/8" (385 mm)

Total Suction Head — Feet	Total Delivery Head — Feet				
	180	220	260	280	300
10	1500	1480	1465	1425	1410
15	1475	1460	1430	1400	1375
20	1380	1270	1200	1160	1115
25	1290	1095	975	920	855

Performance data listed in table and curves based on water tests at sea level and 68°F (20°C). Larger diameter pipes may be required for maximum flows.

## Dimensions

**HL5M** — Caterpillar 3126TA, Skid Base  
**Weight:** 7,200 lbs. (3,266 kg.)

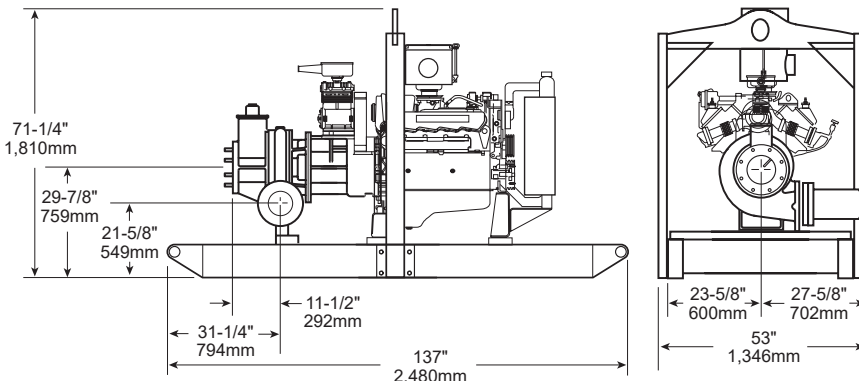

## Specifications

- Maximum Operating Speed:** 2400 rpm
- Maximum Operating Temperature:** +212°F (100°C)
- Maximum Working Pressure:** 216 psi (14.9 BAR)
- Maximum Suction Pressure:** 100 psi (6.9 BAR)
- Maximum Casing Pressure:** 325 psi (22.4 BAR)
- Fuel Tank Capacity:** 175 gal. (662 liters)
- Fuel Consumption:** 11.7 gph (44.28 lph) @ 2400 rpm (full load & max. speed)
- Pipe Connections:** Suction: 6" (150mm) 150# flange; Discharge: 6" (150mm) 150# flange
- Solids Handling:** 1-3/8" (35mm) diameter

## Materials

- Pump Casing, Suction Cover, and Wearplates:** 26% Chrome Iron (optional close grained cast iron available)
- Impeller:** Cast Chromium Steel hardened to minimum Brinell 341 HB
- Shaft:** 1-1/2" Nickel/Chromium steel
- Non Return Valve Body, Ejector Housing:** Close Grained Cast Iron
- Non Return Valve Flapper:** High nitrile rubber
- Mechanical Seal Faces:** Solid silicon carbide

One Floodgate Road, Bridgeport, NJ 08014, USA  
 (856) 467-3636 • Fax: (856) 467-4841

Quenington, Cirencester, Glos., GL7 5BX, UK  
 +44 (0)1285 750271 • Fax: +44 (0)1285 750352

E-mail: sales@godwinpumps.com  
 www.godwinpumps.com

### BRANCH LOCATIONS:

- Norwich, CT • Buffalo, NY • Pittsburgh, PA • Chicago, IL
- Washington, DC • Richmond, VA • Virginia Beach, VA
- Charleston, WV • Raleigh, NC • Charlotte, NC
- N. Charleston, SC • Atlanta, GA • Houston, TX
- San Antonio, TX • Helena, MT • Los Angeles, CA

Dri-Prime® and the color orange for pumps are registered trademarks of Godwin Pumps of America, Inc. Specifications and illustrations are subject to revision without notice. © Copyright 2002-2003 Godwin Pumps of America, Inc.

GPASL.024.903



SOLD BY



info@aquosis.com  
 1.877.907.7852