

Corning Life Sciences

# Cell Culture Media and Reagents Product Selection Guide

CORNING



European Edition



[www.corning.com/lifesciences/solutions](http://www.corning.com/lifesciences/solutions)

## Beginning-to-end Solutions from Corning

At Corning, we continuously strive towards improving efficiencies and developing new products and technologies to support researchers in their life science workflows.

The Corning product line, combined with Corning's disposable vessels, liquid handling products, and unique surfaces provides researchers with a comprehensive portfolio of products for life science research. Browse our portfolio at [www.corning.com/lifesciences](http://www.corning.com/lifesciences).

### Ordering Products Direct

Corning products are manufactured by Mediatech, Inc., a Corning subsidiary. Corning products are available directly from Corning's European Distribution Center. To place your order call Customer Service:

<b>France</b> t 0800 916 882 f 0800 918 636	<b>United Kingdom</b> t 0800 376 8660 f 0800 279 1117
<b>Germany</b> t 0800 101 1153 f 0800 101 2427	<b>All Other European Countries</b> t 31 (0) 20 659 60 51 f 31 (0) 20 659 76 73
<b>The Netherlands</b> t 31 20 655 79 28 f 31 20 659 76 73	

Email: [cceurnl@corning.com](mailto:cceurnl@corning.com)

Online: [www.corning.com/lifesciences/media](http://www.corning.com/lifesciences/media)

### Phone/Fax Online Orders

For each order, customers should provide the Corning product number, product description, and desired quantity. You should also include your billing and shipping address and your account number.

To purchase Corning products online, please visit [www.corning.com/lifesciences/media](http://www.corning.com/lifesciences/media).

### Ordering Products Through our Distribution Partners

Customers can purchase Corning products from any one of our authorized distributors. See our complete listing of Corning distributors at:

[www.corning.com/lifesciences/media](http://www.corning.com/lifesciences/media)

Our distribution partners can offer our customers a variety of value added services from local inventory and service, to managed services and preferred programs. Please contact your distributor of choice for more details.

### Pricing

Prices shown on [www.corning.com/lifesciences/media](http://www.corning.com/lifesciences/media) reflect our current suggested U.S. list price. For customer-specific pricing information, please contact your sales representative or your authorized distributor.

### Technical Support

For technical support:

<b>France</b> t 0800 916 882	<b>United Kingdom</b> t 0800 376 8660
<b>Germany</b> t 0800 101 1153	<b>All Other European Countries</b> t 31 (0) 20 659 60 51
<b>The Netherlands</b> t 31 20 655 79 28	

Email: [scientificsupporteu@corning.com](mailto:scientificsupporteu@corning.com)

**CORNING** | **FALCON**® | **AXYGEN**® | **PYREX**® | **GOSSELIN**™

Corning products are manufactured by Mediatech, Inc., a Corning Subsidiary.  
For a listing of trademarks, visit us at [www.corning.com/lifesciences/media/about-us/trademarks.html](http://www.corning.com/lifesciences/media/about-us/trademarks.html)  
All other trademarks in this document are the property of their respective owners.

# Contents

CORNING

<b>Classical Media</b> .....	6	Dialyzed FBS.....	20
CMRL 1066.....	8	ES Cell-tested FBS.....	20
DMEM (Dulbecco's Modification of Eagle's Medium).....	6	Gamma-irradiated FBS.....	20
DMEM/Ham's F-12 50/50 Mix (Modification).....	7	Low IgG FBS.....	20
F-12K Nutrient Mixture (Kaighn's Modification).....	7	Tetracycline Negative FBS.....	20
Glasgow's MEM.....	7	<b>Cell Culture Reagents</b> .....	21
Ham's F-10 Medium.....	7	Amino Acids and Vitamins.....	22
Ham's F-12 Medium.....	7	Antibiotics and Antimycotics.....	23-24
Improved MEM (Richter's Modification).....	8	Buffers.....	25
IDMEM (Iscove's Modification of DMEM).....	8	Non-enzymatic Cell Dissociation Agents.....	26
Leibovitz's L-15 (Modification).....	8	Growth Supplements.....	26
MCDB 131.....	8	Hybridoma Reagents.....	26
McCoy's 5A (Iwakata and Grace Modification).....	8	Miscellaneous Reagents.....	26
Medium 199 (Modification).....	9	<b>Microbiology and Molecular Biology</b> .....	29
MEM (Minimum Essential Medium).....	9	Miller's LB Broth.....	30
MEM - Alpha Medium.....	10	S.O.C Medium.....	30
RPMI 1640.....	10	Terrific Broth.....	30
<b>Buffered Salt Solutions</b> .....	11	Ampicillin.....	30
DPBS (Dulbecco's Phosphate Buffered Saline).....	12	Carbenicillin.....	30
PBS (Phosphate Buffered Saline).....	12	Kanamycin Sulfate.....	30
HBSS (Hanks' Balanced Salt Solution).....	13	Neomycin Sulfate.....	30
<b>Serum-Free and Specialty Media</b> .....	15	Streptomycin Sulfate.....	30
SF Medium.....	16	Tetracycline Hydrochloride.....	31
PF Medium.....	16	X-Gal.....	31
transfectagro™ Medium.....	16	IPTG.....	31
LSM (Lymphocyte Separation Medium).....	16	PBS.....	31
TSB (Tryptic Soy Broth).....	16	SSC.....	31
Hepatocyte Maintenance Medium.....	17	SSPE.....	31
hybrigro™ SF Medium.....	17	TAE Buffer.....	31
stemgro® HMSC Medium.....	17	TBE Buffer.....	31
rhAlbumin.....	17	TE Buffer.....	32
rhLactoferrin.....	17	Tris Buffered Saline.....	32
Insect Media.....	18	Tris-HCl Buffers.....	32
Grace's Insect Basal Medium.....	18	EDTA.....	32
Hink's TNM-FH Medium.....	18	SDS.....	32
insectagro® DS2.....	18	Sodium Acetate.....	32
insectagro Sf9.....	18	Sodium Chloride.....	32
Poloxamer 188.....	18	<b>High Quality Water</b> .....	33
Polysucrose 400.....	18	Water, WFI Quality.....	34
<b>Human and Animal Sera</b> .....	19	Molecular Biology Grade Water.....	34
Fetal Bovine Serum.....	20	Reagent Grade Water.....	34
Donor Calf Serum.....	20	<b>Flexible Packaging Systems</b> .....	35
Donor Horse Serum.....	20	<b>Formulations</b> .....	49
Human AB Serum.....	20		
Charcoal-stripped FBS.....	20		

# Quality Standards for Corning® Products

Manufactured by Mediatech, Inc.  
Made in the U.S.A.

Corning media products are manufactured by Mediatech, Inc. in the United States, to the highest quality standards. Mediatech's three decades of manufacturing history demonstrates its consistent ability to provide customer value through industry-leading product and process quality. United States manufacturing is held to the highest expectations of governmental regulators and product quality by a discerning marketplace.

## Current Good Manufacturing Practices

Current Good Manufacturing Practices (cGMP) were developed by the Food and Drug Administration (FDA) with the purpose of preventing the intentional or unintentional adulteration of the safety, purity, and efficacy of pharmaceuticals and medical devices used to treat and diagnose patients.

Mediatech follows current Good Manufacturing Practices for all catalog and custom products. cGMPs are prescribed by the FDA Quality Systems Regulation (21 CFR Part 820) which requires establishing a quality system for the design, manufacture, packaging, labeling, storage, installation, and servicing of finished medical devices intended for commercial distribution in the United States. A typical device quality system requires:

- ▶ The formalization, validation, standardization, and documentation of all operational procedures, systems, functions, facilities, materials, and equipment.
- ▶ Institution of procurement, packaging, and labeling controls. Regular validation of equipment and processes to ensure that they continue to meet specified design criteria.
- ▶ Internal quality assurance audits be performed to verify that quality system functions are maintained.
- ▶ Documentation of device distribution and traceability of components.
- ▶ Established Standard Operating Procedures (SOP) for all processes.

## ISO Certification

Mediatech is certified to current ISO 13485 Medical Devices Quality Management Systems - Requirements for Regulatory Purposes. This standard developed by the International Organization for Standardization (ISO) has qualified Mediatech to the highest global standards for a medical device company. This includes medical device requirements relating to:

- ▶ Device design control
- ▶ Manufacturing process controls
- ▶ Supplier management
- ▶ Traceability
- ▶ Record retention

Mediatech undergoes routine audits by an authorized certification body to maintain ISO certification. All products, catalog and custom, are manufactured following the current ISO 13485 standards.

## Regulatory Affairs and Compliance

Mediatech is an FDA registered facility.

Products meeting the requirement of the FDA's in vitro diagnostic medical device are sold in the US with labeling that states "For In Vitro Diagnostic Use."

Mediatech's registration listing with the FDA can be viewed by visiting the following website and searching for "Mediatech" as the establishment name:

<http://www.accessdata.fda.gov/scripts/cdrh/cfdocs/cfRL/rl.cfm>

## Audits

### Customer Audits

Mediatech welcomes quality audits by our current and potential customers.

### Regulatory Agency Audits

As an FDA registered medical device manufacturer, Mediatech may be subject to periodic cGMP audits by the FDA, at their discretion. In addition Mediatech understands that many of our customers are also subject to various regulatory agency audits and we are willing to offer our support for products purchased from us that may be reviewed during these regulatory agency audits.

## Sterility Assurance Level

All media products are sterile-filtered and filled aseptically by industry-standard methods since terminal sterilization methods would destroy valuable components of the formulations.

- ▶ The Sterility Assurance Level (SAL) is the industry's standard of  $10^{-3}$ .
- ▶ Our processes and facility design ensure that there is no more than one random contaminant per 1,000 units.
- ▶ Through continuous improvement, we constantly seek to provide a sterility assurance level that is as low as is reasonably possible.

## Final Quality Testing

Mediatech meets strict testing requirements for all products as dictated by our Quality Systems, customer demands, and product application requirements.

*To meet and exceed these specifications, we:*

- ▶ Use bulk WFI (Water for Injection) to formulate all liquid products
- ▶ Test incoming raw materials from approved suppliers
- ▶ Perform in-process testing of manufactured products

*Finished products are:*

- ▶ Extensively tested to ensure that they meet stringent release criteria
- ▶ Tested in accordance with current U.S. Pharmacopoeia, European Pharmacopoeia, and proprietary methods where applicable
- ▶ Use an electronic, barcode-based system to ensure the correct components are present in the appropriate quantities for a given formulation
- ▶ Tested to meet functional, biological, and physicochemical requirements

## A System that Ensures Success

Corning media products are of the highest quality because of these standards and systems. You rely on your reagents to ensure the best outcome for your work and you can be confident in choosing Corning.

Mediatech stands behind its guarantees of strict production documentation, high purity, and consistency between production lots. When results matter, trust Corning for your research needs.

# 1 Classical Media

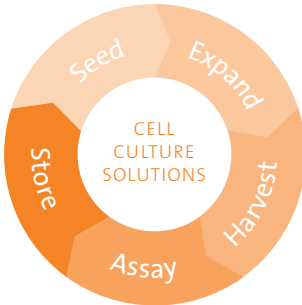

## Growth Promotion and Cytotoxicity

Corning® Classical Media products undergo a variety of tests to determine functionality and toxicity using growth-promotion analysis. Product performance is measured by harvest-to-plant ratios or fold increase according to predetermined specifications.

## Physiochemical Properties

Liquid and powder classical media products are tested to determine pH and osmolality. Classical media Powders are also tested for residual moisture. The pH and osmolality tests are performed according to specific procedures in which all equipment is calibrated using standards traceable to the National Institute of Standards and Technology.

## Biological Tests

Testing of Corning liquid classical media products guarantees low levels of endotoxin, mycoplasma, and an absence of contamination.

**Endotoxin:** Classical media products are tested for bacterial endotoxin using the Limulus Amoebocyte Lysate (LAL) Chromogenic Assay. For release, each lot of standard liquid classical media must have an endotoxin level of <0.25 EU/mL. Classical media powder products must have an endotoxin level of <0.25 EU/mL when reconstituted to formula weight with low endotoxin water.

**Sterility:** All Corning liquid classical media products are tested for sterility.

**Mycoplasma:** Liquid classical media products are tested for mycoplasma off-site using a large-volume method.



CLASSICAL MEDIA

DMEM (Dulbecco's Modification of Eagle's Medium)

Contains	Cat. No.												
	10-101	10-102	10-013	10-014	10-017	10-027	15-013	15-017	15-018	17-204	17-205	17-206	17-207
L-Glutamine			◆	◆	◆	◆							
Sodium pyruvate			◆	◆			◆		◆	◆	◆	◆	
Phenol red			◆	◆	◆	◆	◆	◆	◆	◆		◆	◆
L-Cystine/ L-Methionine			◆	◆	◆	◆	◆	◆	◆		◆	◆	◆
Phosphate			◆	◆	◆	◆	◆	◆	◆	◆	◆		◆
HEPES						◆		◆					
Low glucose				◆									
High glucose			◆		◆	◆	◆	◆	◆	◆	◆	◆	
Glutagro	◆	◆											

Contains	Cat. No.			
	50-003	50-013	90-013	90-113
L-Glutamine	◆	◆		
Sodium pyruvate	◆			
Phenol red	◆	◆		
L-Cystine/L-Methionine	◆	◆	◆	◆
Phosphate	◆	◆	◆	◆
HEPES				
High glucose	◆	◆	◆	
Sodium bicarbonate				

Liquid ♦

Cat. No.	Description	Storage	Expires	Size	Qty/Pk
10-013-CVR	[+] 4.5 g/L-Glucose, L-glutamine, sodium pyruvate	2 to 8°C	18 m	500 mL	6
10-013-CMR	[+] 4.5 g/L-Glucose, L-glutamine, sodium pyruvate	2 to 8°C	18 m	1L	6
10-013-LXR	[+] 4.5 g/L-Glucose, L-glutamine, sodium pyruvate	2 to 8°C	18 m	10L	1
10-013-LBR	[+] 4.5 g/L-Glucose, L-glutamine, sodium pyruvate	2 to 8°C	18 m	20L	1
10-014-CVR	[+] 1.0 g/L-Glucose, sodium pyruvate, L-glutamine	2 to 8°C	18 m	500 mL	6
10-014-CMR	[+] 1.0 g/L-Glucose, sodium pyruvate, L-glutamine	2 to 8°C	18 m	1L	6
10-017-CVR	[+] 4.5 g/L-Glucose, L-glutamine; [-] sodium pyruvate	2 to 8°C	18 m	500 mL	6
10-017-CMR	[+] 4.5 g/L-Glucose, L-glutamine; [-] sodium pyruvate	2 to 8°C	18 m	1L	6
New 10-027-CVR	[+] 25 mM HEPES, 4.5 g/L-Glucose, L-glutamine; [-] sodium pyruvate	2 to 8°C	18 m	500 mL	6
15-013-CVR	[+] 4.5 g/L-Glucose, sodium pyruvate; [-] L-glutamine	2 to 8°C	18 m	500 mL	6
15-013-CMR	[+] 4.5 g/L-Glucose, sodium pyruvate; [-] L-glutamine	2 to 8°C	18 m	1L	6
15-013-LXR	[+] 4.5 g/L-Glucose, sodium pyruvate; [-] L-glutamine	2 to 8°C	18 m	10L	1
15-013-LBR	[+] 4.5 g/L-Glucose, sodium pyruvate; [-] L-glutamine	2 to 8°C	18 m	20L	1
15-017-CVR	[+] 4.5 g/L-Glucose; [-] L-glutamine, sodium pyruvate	2 to 8°C	18 m	500 mL	6
15-017-CMR	[+] 4.5 g/L-Glucose; [-] L-glutamine, sodium pyruvate	2 to 8°C	18 m	1L	6
15-018-CVR	[+] 4.5 g/L-Glucose, sodium pyruvate, 25 mM HEPES; [-] L-glutamine	2 to 8°C	18 m	500 mL	6
15-018-CMR	[+] 4.5 g/L-Glucose, sodium pyruvate, 25 mM HEPES; [-] L-glutamine	2 to 8°C	18 m	1L	6
17-204-CIR	[+] 4.5 g/L-Glucose, sodium pyruvate; [-] L-glutamine, L-methionine, L-cystine	2 to 8°C	18 m	100 mL	6
17-205-CVR	[+] 4.5 g/L-Glucose, sodium pyruvate; [-] L-glutamine, phenol red	2 to 8°C	18 m	100 mL	6
17-206-CIR	[+] 4.5 g/L-Glucose, sodium pyruvate; [-] L-glutamine, phosphate	2 to 8°C	18 m	100 mL	6
17-207-CVR	[-] Glucose, L-glutamine, sodium pyruvate	2 to 8°C	18 m	500 mL	6
New 10-101-CVR	[+] Corning® glutagro® supplement, 4.5 g/L-Glucose, sodium pyruvate, phenol red	2 to 8°C	12 m	500 mL	6
New 10-102-CVR	[+] Corning glutagro® supplement, 4.5 g/L-Glucose, phenol red; [-] sodium pyruvate	2 to 8°C	12 m	500 mL	6

Powder ▲

Cat. No.	Description	Storage	Expires	Size*	Qty/Pk
50-003-PBR	[+] 4.5 g/L-Glucose, L-glutamine, sodium pyruvate; [-] sodium bicarbonate	2 to 8°C	36 m	10L	1
50-003-PCR	[+] 4.5 g/L-Glucose, L-glutamine, sodium pyruvate; [-] sodium bicarbonate	2 to 8°C	36 m	50L	1
50-013-PBR	[+] 4.5 g/L-Glucose, L-glutamine; [-] sodium pyruvate, sodium bicarbonate	2 to 8°C	36 m	10L	1
50-013-PCR	[+] 4.5 g/L-Glucose, L-glutamine; [-] sodium pyruvate, sodium bicarbonate	2 to 8°C	36 m	50L	1
90-013-PBR	[+] 4.5 g/L-Glucose; [-] sodium bicarbonate, L-glutamine, sodium pyruvate, phenol red	2 to 8°C	36 m	10L	1
90-113-PBR	[-] Sodium bicarbonate, glucose, L-glutamine, sodium pyruvate, phenol red	2 to 8°C	36 m	10L	1

\*Powder media volume indicated is the reconstituted volume

## DMEM/Ham's F-12 50/50 Mix

Contains	Cat. No.					Powder	
	10-090	10-092	10-103	15-090	16-405	90-090	90-091
L-Glutamine	◆	◆			◆		
Sodium pyruvate	◆	◆		◆	◆	◆	◆
Phenol red	◆	◆		◆			◆
HEPES		◆					
Glutagro			◆				
Sodium bicarbonate	◆	◆		◆	◆		

### Liquid ◆

Cat. No.	Description	Storage	Expires	Size	Qty/Pk
10-090-CVR	[+] L-Glutamine	2 to 8°C	12 m	500 mL	6
New 10-090-CMR	[+] L-Glutamine	2 to 8°C	12 m	1L	6
10-092-CVR	[+] L-glutamine, 15 mM HEPES	2 to 8°C	12 m	500 mL	6
10-092-CMR	[+] L-glutamine, 15 mM HEPES	2 to 8°C	12 m	1L	6
16-405-CVR	[+] L-glutamine; [-] phenol red	2 to 8°C	12 m	500 mL	6
15-090-CVR	[+] L-glutamine	2 to 8°C	18 m	500 mL	6
15-090-CMR	[-] L-glutamine	2 to 8°C	18 m	1L	6
New 10-103-CVR	[+] Corning® glutagro™ Supplement	2 to 8°C	36 m	500 mL	6

### Powder ⚡

Cat. No.	Description	Storage	Expires	Size*	Qty/Pk
90-090-PBR	[-] Sodium bicarbonate, L-glutamine, phenol red	2 to 8°C	36 m	10L	6
90-091-PBR	[+] L-Glutamine	2 to 8°C	36 m	10L	6

## F-12K Nutrient Mixture (Kaighn's Modification), 1x

Cat. No.	Description	Storage	Expires	Size	Qty/Pk
10-025-CVR	[+] L-Glutamine	2 to 8°C	12 m	500 mL	6

## Glasgow's MEM

### Powder ⚡

Cat. No.	Description	Storage	Expires	Size*	Qty/Pk
50-004-PBR	[+] L-glutamine; [-] sodium bicarbonate, tryptose phosphate broth	2 to 8°C	36 m	10L	1

## Ham's F-10 Medium

Cat. No.	Description	Storage	Expires	Size	Qty/Pk
10-070-CVR	[+] L-Glutamine	2 to 8°C	12 m	500 mL	6

## Ham's F-12 Medium

### Liquid ◆

Cat. No.	Description	Storage	Expires	Size	Qty/Pk
10-080-CVR	[+] L-Glutamine	2 to 8°C	12 m	500 mL	6
10-080-CMR	[+] L-Glutamine	2 to 8°C	12 m	1L	6

### Powder ⚡

Cat. No.	Description	Storage	Expires	Size*	Qty/Pk
50-040-PBR	[+] L-glutamine; [-] sodium bicarbonate	2 to 8°C	36 m	10L	1

\*Powder media volume indicated is the reconstituted volume

### Improved MEM (Richter's Modification), 1x

Cat. No.	Description	Storage	Expires	Size	Qty/Pk
10-024-CVR	[+] L-Glutamine	2 to 8°C	12 m	500 mL	6
10-026-CVR	[+] l-glutamine; [-] phenol red	2 to 8°C	12 m	500 mL	6

### Iscove's Modification of DMEM, 1x

Contains	Cat. No.		
	10-016	15-016	50-016
L-Glutamine	◆		◆
Sodium pyruvate	◆	◆	◆
Phenol red	◆	◆	◆
Sodium bicarbonate	◆	◆	

Cat. No.	Description	Storage	Expires	Size	Qty/Pk
10-016-CVR	[+] L-Glutamine	2 to 8°C	12 m	500 mL	6
10-016-CMR	[+] L-glutamine and 25 mM HEPES; [-] α-thioglycerol, β-mercaptoethanol	2 to 8°C	12 m	1L	6
15-016-CVR	[+] 25 mM HEPES; [-] α-thioglycerol, β-mercaptoethanol, L-glutamine	2 to 8°C	12 m	500 mL	6

#### Powder 🍷

Cat. No.	Description	Storage	Expires	Size*	Qty/Pk
50-016-PB	[+] 25 mM HEPES; [-] α-thioglycerol, β-mercaptoethanol, sodium bicarbonate	2 to 8°C	36 m	10L	1

### Leibovitz's L-15 (Modification), 1x

#### Liquid 🍷

Cat. No.	Description	Storage	Expires	Size	Qty/Pk
10-045-CVR	[+] L-Glutamine	2 to 8°C	12 m	500 mL	6

#### Powder 🍷

Cat. No.	Description	Storage	Expires	Size*	Qty/Pk
50-045-PBR	[+] L-glutamine; [-] phenol red	2 to 8°C	12 m	10L	1

### MCDB 131, 1x

Cat. No.	Description	Storage	Expires	Size	Qty/Pk
15-100-CVR	[-] L-Glutamine	2 to 8°C	12 m	500 mL	6

### McCoy's 5A (Iwaketa and Grace Modification), 1x

Contains	Cat. No.	
	10-050	10-051
L-Glutamine	◆	◆
Phenol red	◆	◆
HEPES		◆
Sodium bicarbonate	◆	◆

Cat. No.	Description	Storage	Expires	Size	Qty/Pk
10-050-CVR	[+] L-Glutamine	2 to 8°C	18 m	500 mL	6
10-051-CIR	[+] L-glutamine, 25 mM HEPES	2 to 8°C	18 m	100 mL	6

### CMRL 1066

Cat. No.	Description	Storage	Expires	Size	Qty/Pk
15-110-CVR	[-] L-glutamine	2 to 8°C	36 m	500 mL	6

\*Powder media volume indicated is the reconstituted volume

### Medium 199 (Modification)

Contains	Cat. No.			
	10-060	50-050	50-051	90-050
L-Glutamine	◆	◆	◆	
Phenol red	◆	◆	◆	
Earle's salts	◆	◆		◆
Hanks salts			◆	
Sodium bicarbonate	◆			

#### Liquid

Cat. No.	Description	Storage	Expires	Size	Qty/Pk
10-060-CVR	[+] Earle's salts, L-glutamine	2 to 8°C	18 m	500 mL	6

#### Powder

Cat. No.	Description	Storage	Expires	Size*	Qty/Pk
50-050-PBR	[+] Earle's salts, L-glutamine; [-] sodium bicarbonate	2 to 8°C	36 m	10L	1
50-051-PBR	[+] Hanks salts, L-glutamine, sodium bicarbonate	2 to 8°C	36 m	10L	1
90-050-PB	[+] Earle's salts; [-] sodium bicarbonate, L-glutamine, phenol red	2 to 8°C	36 m	10L	1

### MEM (Minimum Essential Medium)

Contains	Cat. No.									
	10-009	10-010	15-010	15-015	17-305	50-010	50-011	50-019	51-010	90-009
L-Glutamine	◆	◆				◆	◆	◆		
Phenol red	◆	◆	◆	◆		◆	◆	◆	◆	
Calcium and magnesium	◆	◆	◆		◆	◆	◆	◆	◆	◆
Sodium bicarbonate	◆	◆	◆	◆	◆					
Non-essential amino acids	◆						◆			
Sodium pyruvate	◆									
Earle's salts	◆	◆	◆	◆	◆	◆	◆		◆	◆
Hank's salts								◆		

#### Liquid

Cat. No.	Description	Storage	Expires	Size	Qty/Pk
10-009-CVR	[+] Sodium bicarbonate, NEAA, L-glutamine, sodium pyruvate	2 to 8°C	18 m	500 mL	6
10-010-CVR	[+] Earle's salts, L-glutamine	2 to 8°C	18 m	500 mL	6
10-010-CMR	[+] Earle's salts, L-glutamine	2 to 8°C	18 m	1L	6
15-010-CVR	[+] Earle's salts; [-] L-glutamine	2 to 8°C	18 m	500 mL	6
15-010-CMR	[+] Earle's salts; [-] L-glutamine	2 to 8°C	18 m	1L	6
17-305-CVR	[+] Earle's salts; [-] L-glutamine, phenol red	2 to 8°C	18 m	500 mL	6
15-015-CVR	[-] L-glutamine, calcium, magnesium	2 to 8°C	18 m	500 mL	6

#### Powder

Cat. No.	Description	Storage	Expires	Size*	Qty/Pk
50-010-PBR	[+] Earle's salts, L-glutamine; [-] sodium bicarbonate	2 to 8°C	36 m	10L	1
50-010-PCR	[+] Earle's salts, L-glutamine; [-] sodium bicarbonate	2 to 8°C	36 m	50L	1
90-009-PBR	[+] Earle's salts; [-] L-glutamine, phenol red, sodium bicarbonate	2 to 8°C	36 m	10L	1
50-011-PBR	[+] Earle's salts, L-glutamine, NEAA; [-] sodium bicarbonate	2 to 8°C	36 m	10L	1
50-011-PCR	[+] Earle's salts, L-glutamine, NEAA; [-] sodium bicarbonate	2 to 8°C	36 m	50L	1
51-010-PCR	[+] Earle's salts; [-] sodium bicarbonate, L-glutamine	2 to 8°C	36 m	50L	1
50-019-PBR	[+] Hanks salts, L-glutamine; [-] sodium bicarbonate	2 to 8°C	36 m	50L	1

\*Powder media volume indicated is the reconstituted volume

### MEM (Minimum Essential Medium) Alpha Medium

Contains	Cat. No.		
	10-022	15-012	Powder 50-012
L-Glutamine	◆		◆
Phenol red	◆	◆	◆
Nucleosides	◆		
Sodium pyruvate	◆	◆	◆
Sodium bicarbonate	◆	◆	

#### Liquid

Cat. No.	Description	Storage	Expires	Size	Qty/Pk
10-022-CVR	[+] Earle's salts, ribonucleosides, deoxyribonucleosides, L-glutamine	2 to 8°C	12 m	500 mL	6
15-012-CVR	[+] Earle's salts; [-] ribonucleosides, deoxyribonucleosides, L-glutamine	2 to 8°C	18 m	500 mL	6

#### Powder

Cat. No.	Description	Storage	Expires	Size*	Qty/Pk
50-012-PCR	[+] Earle's salts, L-glutamine ; [-] ribonucleosides, deoxyribonucleosides, sodium bicarbonate	2 to 8°C	36 m	50L	1

### RPMI 1640

Contains	Cat. No.								Powder	
	10-040	10-041	10-043	10-104	15-040	15-041	17-104	17-105	50-020	90-022
L-Glutamine	◆	◆	◆						◆	
Phenol red	◆	◆	◆	◆	◆	◆	◆		◆	
HEPES		◆				◆				
L-Cystine / L-Methionine	◆	◆	◆	◆	◆	◆		◆	◆	◆
Sodium bicarbonate	◆	◆	◆	◆	◆	◆	◆	◆		
glutagro™				◆						

#### Liquid

Cat. No.	Description	Storage	Expires	Size	Qty/Pk
<b>10-040-CVR</b>	<b>[+] L-Glutamine</b>	2 to 8°C	18 m	500 mL	6
10-040-CMR	[+] L-Glutamine	2 to 8°C	18 m	1L	6
10-040-LXR	[+] L-Glutamine	2 to 8°C	18 m	10L	6
10-040-LBR	[+] L-Glutamine	2 to 8°C	18 m	20L	6
<b>10-104-CVR</b>	<b>[+] Corning® glutagro™ supplement, phenol red</b>	2 to 8°C	18 m	500 mL	6
15-040-CVR	[-] L-Glutamine	2 to 8°C	18 m	500 mL	6
15-040-CMR	[-] L-Glutamine	2 to 8°C	18 m	1L	6
15-040-LBR	[-] L-Glutamine	2 to 8°C	18 m	20L	1
17-105-CVR	[-] L-glutamine, phenol red	2 to 8°C	18 m	500 mL	6
<b>10-041-CVR</b>	<b>[+] L-glutamine and 25 mM HEPES</b>	2 to 8°C	18 m	500 mL	6
10-041-CMR	[+] L-glutamine and 25 mM HEPES	2 to 8°C	18 m	1L	6
10-043-CVR	[+] L-glutamine; [-] glucose	2 to 8°C	18 m	500 mL	6
15-041-CVR	[+] 25 mM HEPES; [-] L-glutamine	2 to 8°C	18 m	500 mL	6
17-104-CIR	[-] L-glutamine, L-methionine, L-cystine	2 to 8°C	18 m	100 mL	6
17-105-CVR	[-] L-glutamine, phenol red	2 to 8°C	18 m	500 mL	6

#### Powder

Cat. No.	Description	Storage	Expires	Size*	Qty/Pk
<b>50-020-PBR</b>	<b>[+] L-glutamine; [-] sodium bicarbonate</b>	2 to 8°C	36 m	10L	1
50-020-PCR	[+] L-glutamine; [-] sodium bicarbonate	2 to 8°C	36 m	50L	1
90-022-PBR	[-] L-glutamine, phenol red, sodium bicarbonate	2 to 8°C	36 m	10L	1

\*Powder media volume indicated is the reconstituted volume

# 2 Buffered Salt Solutions

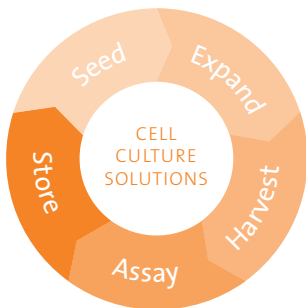

Buffered salt solutions are made to a physiological pH and salt concentration. They are used alone or in combination with other agents for washing tissues and cells. Buffered salt solutions most commonly include sodium, potassium, calcium, magnesium, and chloride. They provide the cells with water and inorganic ions, while maintaining a physiological pH and osmotic pressure.

Although there have been many modifications to the original formulas in efforts to produce fully-defined media, salt solutions still play an important role in tissue culture. A salt solution's basic functions, to maintain the pH and osmotic balance in the medium and to provide the cells with water and essential inorganic ions, are as valuable today as when it was first developed a century ago.

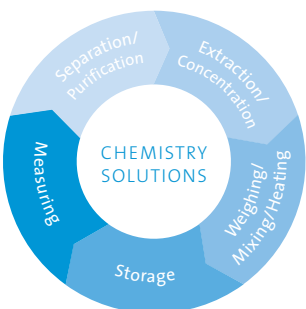
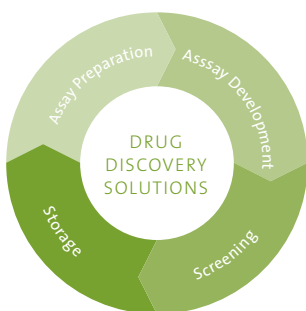

**DPBS (Dulbecco's Phosphate Buffered Saline)**

Contains	Cat. No.						Powder
	20-030	20-031	21-030	21-031	21-040	46-031	55-031
Calcium	◆		◆				
Magnesium	◆		◆				
Potassium chloride	◆	◆	◆	◆		◆	◆

**Liquid** 📌

Cat. No.	Description	Storage	Expires	Size	Qty/Pk
20-030-CVR	[+] Calcium and magnesium, 10x	2 to 30°C	18 m	500 mL	6
20-031-CVR	[-] Calcium and magnesium, 10x	2 to 30°C	18 m	500 mL	6
21-030-CVR	[+] Calcium and magnesium, 1x	2 to 30°C	36 m	500 mL	6
21-030-CMR	[+] Calcium and magnesium, 1x	2 to 30°C	36 m	1L	6
21-031-CVR	[-] Calcium and magnesium, 1x	2 to 30°C	36 m	500 mL	6
21-031-CMR	[-] Calcium and magnesium, 1x	2 to 30°C	36 m	1L	6
21-031-LXR	[-] Calcium and magnesium, 1x	2 to 30°C	36 m	10L	1
21-031-LBR	[-] Calcium and magnesium, 1x	2 to 8°C	36 m	20L	1

**Powder** ⚗️

Cat. No.	Description	Storage	Expires	Size*	Qty/Pk
55-031-PBR	[-] Calcium and magnesium	2 to 8°C	36 m	10L	1
55-031-PCR	[-] Calcium and magnesium	2 to 8°C	36 m	50L	1

\*Powder media volume indicated is the reconstituted volume

**PBS (Phosphate Buffered Saline)**

Cat. No.	Description	Storage	Expires	Size	Qty/Pk
21-040-CVR	[-] Calcium and magnesium, pH 7.4 ± 0.1, 1x	2 to 30°C	24 m	500 mL	6
21-040-CMR	[-] Calcium and magnesium, pH 7.4 ± 0.1, 1x	2 to 30°C	24 m	1L	6
21-040-CMX12R	[-] Calcium and magnesium, pH 7.4 ± 0.1, 1x	2 to 30°C	24 m	1L	12

**HBSS (Hanks Balanced Salt Solution)**

Contains	Cat. No.						Powder	
	20-021	20-023	21-020	21-021	21-022	21-023	55-021	55-022
Calcium		◆	◆			◆		
Magnesium		◆	◆			◆		
Phenol red	◆		◆	◆			◆	
Sodium bicarbonate			◆	◆	◆	◆		

**Liquid** ●

Cat. No.	Description	Storage	Expires	Size	Qty/Pk
20-021-CVR	[-] Sodium bicarbonate, calcium, magnesium	2 to 30°C	36 m	500 mL	6
20-023-CVR	[+] Calcium, magnesium; [-] phenol red, sodium bicarbonate	2 to 30°C	36 m	500 mL	6
21-020-CVR	[+] Calcium, magnesium, 1x	2 to 30°C	36 m	500 mL	6
21-020-CMR	[+] Calcium, magnesium, 1x	2 to 30°C	36 m	1L	6
21-023-CVR	[+] Calcium, magnesium; [-] phenol red, 1x	2 to 30°C	36 m	500 mL	6
21-023-CMR	[+] Calcium, magnesium; [-] phenol red, 1x	2 to 30°C	36 m	1L	6
21-021-CVR	[-] Calcium, magnesium, 1x	2 to 30°C	36 m	500 mL	6
21-021-CMR	[-] Calcium, magnesium, 1x	2 to 30°C	36 m	1L	6
21-022-CVR	[-] Calcium, magnesium, phenol red, 1x	2 to 30°C	36 m	500 mL	6
21-022-CMR	[-] Calcium, magnesium, phenol red, 1x	2 to 30°C	36 m	1L	6

**Powder** ⚡

Cat. No.	Description	Storage	Expires	Size*	Qty/Pk
55-022-PBR	[-] Sodium bicarbonate, calcium, magnesium	2 to 8°C	36 m	10L	1
55-021-PBR	[-] Sodium bicarbonate, calcium, magnesium, phenol red	2 to 8°C	36 m	10L	1

\*Powder media volume indicated is the reconstituted volume



# 3 Serum-free and Specialty Media

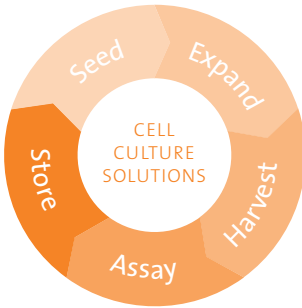

Serum has been extensively used as a supplement to chemically defined media for mammalian cell culture due to its beneficial attributes. As a complex supplement it contains proteins, growth factors, hormones, amino acids, sugars, trypsin inhibitors, and lipids which support vigorous *in vitro* growth of a large number of cell types.

However, there are many negative aspects associated with the use of serum such as cost, time-consuming sampling, lot-to-lot variability, presence of adventitious agents, and availability. These negative aspects are particularly troublesome with the use of serum in the production of recombinant proteins, viral vaccines, cellular therapies, and monoclonal antibodies. In such cases, extensive downstream purification is required to remove serum-derived protein from the medium and to assure the absence of adventitious pathogens.

To minimize those problems associated with the use of serum, several defined, serum-free media have been developed and commercialized. Serum-free growth media pose numerous advantages over the use of serum, including lot-to-lot consistency, reduced foaming, the elimination of exogenous agents, simpler downstream processing, high cell yield support, and fewer regulatory obstacles.



## SF Medium

SF Medium is based on a proprietary combination of classical media formulations. This medium contains a mixture of select trace elements and high molecular weight carbohydrates, extra vitamins, animal origin-free protein, and a small amount of high quality bovine serum albumin (1.0 g/L). SF Medium supports superior growth and viability over long-term passages in hybridomas, as well as suspension and adherent cell cultures. This formulation contains L-glutamine.

Cat. No.	Description	Storage	Expires	Size	Qty/Pk
40-101-CV	[+] L-glutamine, 1 g/L BSA	2 to 8°C	12 m	500 mL	6
40-102-CV	[+] L-glutamine, 1 g/L BSA; [-] phenol red	2 to 8°C	12 m	500 mL	6

## PF Medium

Optimized for the cultivation of Chinese Hamster Ovary (CHO) cells, along with many derivatives of this parent line, PF Medium is a proprietary serum-free and protein-free growth medium that does not contain any hormones or growth factors. This medium supports superior growth and viability over long-term passages in both adherent and suspension culture, and is formulated without L-glutamine.

Cat. No.	Description	Storage	Expires	Size	Qty/Pk
40-200-CV	[-] L-Glutamine	2 to 8°C	12 m	500 mL	6

## transfectagro™ Reduced-serum Medium

transfectagro Reduced-serum Medium is designed to maximize the growth of a variety of cell types under reduced-serum conditions, generally allowing for at least a 50% reduction in serum use with minimal adaptation. A chemically defined, reduced-serum formulation, transfectagro also improves transient transfection efficiency in a variety of cell types.

Cat. No.	Description	Storage	Expires	Size	Qty/Pk
40-300-CVR	[+] Lower levels of calcium and phenol red, HEPES	2 to 8°C	12 m	500 mL	6

## LSM (Lymphocyte Separation Medium)

Lymphocyte Separation Medium was originally designed for the *in vitro* isolation of lymphocytes from diluted whole blood. It is a sterile filtered, iso-osmotic polysucrose and diatrizoate solution with low viscosity and a density of 1.077-1.080 g/mL at 20°C.

Cat. No.	Description	Storage	Expires	Size	Qty/Pk
25-072-CI	LSM, Density - 1.077 - 1.080 g/mL at 20°C	15 to 30°C	18 m	100 mL	1
25-072-CV	LSM, Density - 1.077 - 1.080 g/mL at 20°C	15 to 30°C	18 m	500 mL	1

## TSB (Tryptic Soy Broth)

Tryptic Soy Broth is offered for use in sterility testing and validation in the manufacture of a liquid product. The use of this medium in place of the product intended for production allows for the assessment of the capability of an aseptic manufacturing process. It is a sterile-filtered, ready-to-use solution for the simulation of aseptic filling of liquids and sterility testing. Due to the rich nutrient base, TSB may be used in the cultivation of fastidious microorganisms. This growth medium is free of animal-sourced components, making it ideal for testing the sterility of animal-free biopharmaceutical processes.

### Liquid

Cat. No.	Description	Storage	Expires	Size	Qty/Pk
46-060-CI	Tryptic Soy Broth, animal free	15 to 30°C	12 m	100 mL	1
46-060-CM	Tryptic Soy Broth, animal free	15 to 30°C	12 m	1L	1
 46-060-LB	Tryptic Soy Broth, animal free	15 to 30°C	12 m	20L	1

### Powder

Cat. No.	Description	Storage	Expires	Size	Qty/Pk
61-411-RO	Tryptic Soy Broth, animal free	15 to 30°C	12 m	500 g	1

## Hepatocyte Maintenance Medium



Hepatocyte Maintenance Medium is designed for the *in vitro* cultivation and maintenance of hepatocytes for research applications, drug discovery, and studies related to preclinical drug-induced liver injury. This specialized medium is optimized for primary human hepatocytes. It maintains the physiological relationships between hepatic Phase I and II drug metabolism enzymes as well as influx and efflux transporters. It also meets the long-term high-metabolic needs of hepatocytes. Hepatocyte Maintenance Medium is defined, animal-origin free and serum-free.

Cat. No.	Description	Storage	Expires	Size	Qty/Pk
 40-550-CV	Hepatocyte Maintenance Medium	2 to 8°C	*	500 mL	1

\* Please inquire for lot-specific expiration dates or view the current certificate of analysis at [www.corning.com/lifesciences/media](http://www.corning.com/lifesciences/media)

## hybrigro SF™ Medium

Specifically developed for serum-free growth and antibody production with a variety of hybridoma cell lines, hybrigro SF Medium is a complete, animal component-free, defined medium.

Cat. No.	Description	Storage	Expires	Size	Qty/Pk
 40-215-CVR	hybrigro SF Medium with Corning glutagro™ supplement	2 to 8°C	12 m	500 mL	6
 40-215-LBR	hybrigro SF Medium with Corning glutagro supplement	2 to 8°C	12 m	20L	1

## stemgro® hMSC Medium

Serum-free stemgro hMSC Medium has been designed for the maximum expansion of human mesenchymal stem cells (hMSCs) derived from bone marrow, cord blood, or adipose tissue. stemgro hMSC Medium is defined as its components are either chemically synthesized or recombinantly produced and purified. stemgro hMSC Medium offers the convenience of no vessel coating with biological materials if used with Corning CellBIND® or Primaria™ Surface cell culture vessels, saving the cost of coating materials and time.

Cat. No.	Description	Storage	Expires	Size	Qty/Pk
 40-410-KIT	stemgro hMSC Medium and supplement	-20 to 8°C	12 m	KIT	1

## rhAlbumin

rhAlbumin is a chemically defined recombinant human serum albumin (rhHSA). Having an essential and non-essential fatty acid profile, this is a powerful media supplement that outperforms plasma-derived human serum albumin (pHSA), bovine serum albumin (BSA), and FBS. Some prominent applications for rhAlbumin are as a supplement for CHO cell culture and for the culture of various other cell lines. This product is plant-derived and completely animal-origin free.

### Powder

Cat. No.	Description	Storage	Expires	Size	Qty/Pk
62-450-RF	rhAlbumin	-20 to 8°C	12 m	1 g	1

## rhLactoferrin

rhLactoferrin is a recombinant human holo-lactoferrin specifically intended for use as a cell culture supplement. It is a multi-functional protein that is a potent cell growth factor with anti-apoptotic and antimicrobial properties. This product is plant derived and completely animal-origin free.

### Powder

Cat. No.	Description	Storage	Expires	Size	Qty/Pk
62-451-RF	rhLactoferrin	-20 to 8°C	12 m	1 g	1

## Insect Media

### Grace's Insect Basal Medium (Vaughn Modification)

Cat. No.	Description	Storage	Expires	Size	Qty/Pk
13-200-CV	[+] L-glutamine; [-] insect hemolymph	2 to 8°C	12 m	500 mL	6

### Hink's TNM-FH Medium (Modification) (Supplemented Grace's Medium)

Cat. No.	Description	Storage	Expires	Size	Qty/Pk
13-100-CV	[+] L-glutamine, lactalbumin hydrolysate, UF Yeast Extract; [-] insect hemolymph	2 to 8°C	12 m	500 mL	6

### insectagro® DS2 Serum-Free/Protein-Free Medium, 1x

insectagro DS2 Serum-Free/Protein-Free Medium was developed for the growth and maintenance of *Drosophila Schneider 2* (S2) cells to be used in heterologous protein expression. At the optimal temperature range (22-24°C), DS2 cells grow as a loose monolayer and are readily adaptable to growth in suspension. Under these conditions, the cells require minimal adaptation to serum-free culture.

Cat. No.	Description	Storage	Expires	Size	Qty/Pk
13-402-CV	insectagro DS2 Serum-Free/Protein-Free Medium, 1x [-] L-glutamine	2 to 8°C	12 m	500 mL	6

### insectagro Sf9 Serum-Free/Protein-Free Medium

insectagro Sf9 is formulated to support the propagation of Sf9 insect cells in culture, and can also be used with Sf21 cells. Sf9 cells cultured in non-humidified, non-CO<sub>2</sub> incubators at 27°C (room temperature) display both monolayer and suspension culture qualities. With their fast doubling times of 18-22 hours, Sf9 cells are easily scaled up to large cultures using bioreactors.

Cat. No.	Description	Storage	Expires	Size	Qty/Pk
13-410-CV	insectagro Sf9 Serum-Free/Protein-Free Medium [+] L-glutamine	2 to 8°C	12 m	500 mL	6

### Poloxamer 188

Poloxamer 188 is a synthetic polymer of sucrose and epichlorohydrin used for the density gradient separation of cells, cell membranes, and virus cells. It can also be used to isolate different organelles. This nonionic compound is provided in powder and liquid forms.

#### Liquid

Cat. No.	Description	Storage	Expires	Size	Qty/Pk
13-901-CL	Poloxamer 188	2 to 8°C	12 m	100 mL	6

#### Powder

Cat. No.	Description	Storage	Expires	Size	Qty/Pk
61-161-RM	Poloxamer 188	15 to 30°C	≥12 m	100 g	1

### Polysucrose 400

#### Powder

Cat. No.	Description	Storage	Expires	Size	Qty/Pk
61-196-RM	Polysucrose 400	15 to 30°C	≥12 m	100 g	1
61-196-RO	Polysucrose 400	15 to 30°C	≥12 m	500 g	1

# 4 Human and Animal Sera

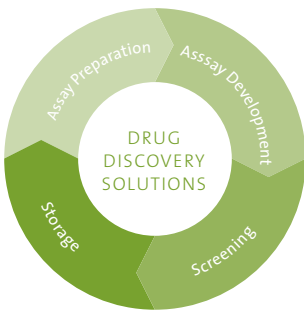
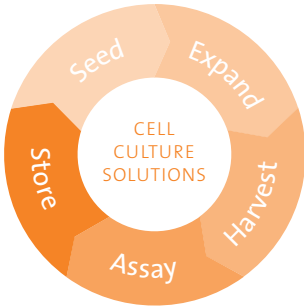

Our high-quality serum products perfectly complement our wide range of sterile-filtered, low-endotoxin, classical cell culture media.

**U.S.-sourced:** U.S.-sourced Premium Fetal Bovine Serum, with the lowest endotoxin and hemoglobin specifications, is collected from cattle herds only within the United States. It is also available heat-inactivated.

**USDA Approved Source:** USDA Approved Source Fetal Bovine Serum, also low in endotoxin and hemoglobin, is collected from abattoirs located in countries free of BSE and FMD and approved by the United States Department of Agriculture (USDA) for bovine product import. The animals are inspected pre- and post-mortem by licensed veterinarians and the material is tested for bovine diseases prior to import and further processing in FDA registered facilities under cGMPs. This is also available heat-inactivated.

Specialty Serum products are also offered by Corning for a variety of product applications.

All sera is separated from the collected blood by refrigerated centrifugation, true-pooled, filtered, and immediately frozen.

Only raw serum that meets our strict specifications for endotoxin, residual hemoglobin and pH is approved for production.



## Fetal Bovine Serum

Fetal Bovine Serum (FBS) is a light brown-colored liquid separated from the blood of the bovine fetus. All material meets the approval of the U.S. Department of Agriculture and is obtained from sources free of BSE, Foot and Mouth Disease, and other reportable diseases pertaining to the species.

Cat. No.	Description	Storage	Expires	Size	Qty/Pk
35-010-CV	Fetal Bovine Serum, Regular	-25 to -15°C	*	500 mL	1
35-011-CV	Fetal Bovine Serum, Regular (Heat inactivated)	-25 to -15°C	*	500 mL	1
35-015-CV	Fetal Bovine Serum, Premium	-25 to -15°C	*	500 mL	1
35-016-CV	Fetal Bovine Serum, Premium (Heat inactivated)	-25 to -15°C	*	500 mL	1
35-070-CV	Fetal Bovine Serum, Premium (Gamma irradiated)	-25 to -15°C	*	500 mL	1
35-071-CV	Fetal Bovine Serum, Premium (Dialyzed)	-25 to -15°C	*	500 mL	1
35-072-CV	Fetal Bovine Serum, Premium (Charcoal stripped)	-25 to -15°C	*	500 mL	1
35-073-CV	Fetal Bovine Serum, Premium (IgG stripped)	-25 to -15°C	*	500 mL	1
35-074-CV	Fetal Bovine Serum, Premium (Embryonic stem cell tested)	-25 to -15°C	*	500 mL	1
35-075-CV	Fetal Bovine Serum, Premium (Tetracycline negative)	-25 to -15°C	*	500 mL	1
<b>New</b> 35-076-CV	Fetal Bovine Serum, Australia Origin	-25 to -15°C	*	500 mL	1

\* Please inquire for lot-specific expiration dates or view the current certificate of analysis at [www.corning.com/lifesciences/media](http://www.corning.com/lifesciences/media)

## Donor Calf Serum, U.S.-Sourced

Donor Calf Serum is a light brown-colored liquid collected from herds of bovine calves located entirely in the United States. Animals are regularly inspected by licensed veterinarians and certified to be free of diseases pertaining to the species.

Cat. No.	Description	Storage	Expires	Size	Qty/Pk
35-022-CV	Donor calf serum, U.S.-sourced	-25 to -15°C	*	500 mL	1

\* Please inquire for lot-specific expiration dates or view the current certificate of analysis at [www.corning.com/lifesciences/media](http://www.corning.com/lifesciences/media)

## Donor Horse Serum, U.S.-Sourced

Donor Horse Serum is a light brown-colored liquid collected from controlled standing herds of animals located entirely in the United States. Animals are inspected periodically by a licensed veterinarian. Diet and worming are strictly controlled and documented to ensure all animals are healthy. Each lot of Donor Horse Serum is extensively tested, and must be negative for Equine Infectious Anemia (EIA) and Equine Viral Arteritis (EVA). Chemical constituents are measured further to ensure lot-to-lot consistency.

Cat. No.	Description	Storage	Expires	Size	Qty/Pk
35-030-CV	Donor horse serum, U.S.-sourced	-25 to -15°C	*	500 mL	1

\* Please inquire for lot-specific expiration dates or view the current certificate of analysis at [www.corning.com/lifesciences/media](http://www.corning.com/lifesciences/media)

## Human AB Serum

Human AB Serum is processed from donor plasma collected at U.S. centers. Each donor unit of plasma is negative for Hepatitis B (HBsAg), Hepatitis C (anti-HCV), Human Immunodeficiency Virus-1 (HIV-1), Human Immunodeficiency Virus-2 (HIV-2), Human Immunodeficiency Virus antibody (HIV-1Ag), and ALT by FDA approved methods.

Cat. No.	Description	Storage	Expires	Size	Qty/Pk
35-060-CI	Human AB Serum	-25 to -15°C	*	100 mL	1

\* Please inquire for lot-specific expiration dates or view the current certificate of analysis at [www.corning.com/lifesciences/media](http://www.corning.com/lifesciences/media)

# 5 Cell Culture Reagents

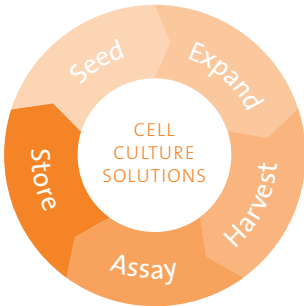

Growth media is used either for cell culture or microbiological culture. These cultures require nutrients, supplements, buffers, and other reagents specific to the product being grown to maximize results and consistency.

There are two major types of growth media: those used for cell culture, which use specific cell types derived from plants or animals, and microbiological culture, which are used for growing microorganisms, such as bacteria or yeast.

Specialized media are sometimes required for microorganism and cell culture growth. Some organisms, termed fastidious organisms, require specialized environments due to complex nutritional requirements. Viruses, for example, are obligate intracellular parasites and require a growth medium composed of living cells.



## Amino Acids and Vitamins

### Supplementation table for L-Glutamine and glutagro™ Supplement.

Media	mg/L	mM	200 mM L-Glutamine (Cat. No. 25-005) or 200 mM glutagro Supplement (Cat. No. 25-015-CI)
AMEM	292	2.00	10.0 mL/L
BME	292.3	2.00	10.0 mL/L
DMEM	584	4.00	20.0 mL/L
DMEM/F12	362.1	2.48	12.4 mL/L
F12K	292	2.00	10.0 mL/L
Ham's F-10	146.2	1.00	5.0 mL/L
Ham's F-12	146.2	1.00	5.0 mL/L
Iscove's DMEM	584	4.00	20.0 mL/L
M199	100	0.68	3.4 mL/L
EMEM	292	2.00	10.0 mL/L
RPMI 1640	300	2.05	10.3 mL/L

### glutagro Supplement

glutagro Supplement is a stabilized dipeptide form of L-Glutamine which does not degrade in liquid media during storage or incubation, providing superior results in several applications.

Cat. No.	Description	Storage	Expires	Size	Qty/Pk
 25-015-CI	glutagro Supplement, 200 mM solution, 100x (with 8.5 g/L NaCl)	2 to 30°C	24 m	100 mL	1

### L-Glutamine

#### Liquid

Cat. No.	Description	Storage	Expires	Size	Qty/Pk
25-005-CIR	L-glutamine, 200 mM solution, 100x (with 8.5 g/L NaCl)	-25 to -15°C	24 m	500 mL	6
25-005-CVR	L-glutamine, 200 mM solution, 100x (with 8.5 g/L NaCl)	-25 to -15°C	24 m	500 mL	6

#### Powder

Cat. No.	Description	Storage	Expires	Size	Qty/Pk
61-030-RM	L-Glutamine	2 to 8°C	12 m	100 g	1
61-030-RO	L-Glutamine	2 to 8°C	12 m	500 g	1
61-030-RR	L-Glutamine	2 to 8°C	12 m	1 kg	1

### MEM Amino Acids

Cat. No.	Description	Storage	Expires	Size	Qty/Pk
25-030-CIR	[ $\pm$ ] L-glutamine, 50x	2 to 8°C	36 m	100 mL	6

### MEM Non-essential Amino Acids

Cat. No.	Description	Storage	Expires	Size	Qty/Pk
25-025-CIR	MEM non-essential amino acids, 100x	2 to 8°C	18 m	100 mL	6

### MEM Vitamins

Cat. No.	Description	Storage	Expires	Size	Qty/Pk
25-020-CIR	MEM vitamins, 100x	-25 to -15°C	18 m	100 mL	6

# Antibiotics and Antimycotics

## Amphotericin B

Cat. No.	Description	Storage	Expires	Size	Qty/Pk
30-003-CF	Amphotericin B, Liquid	-25 to -15°C	18 m	50 mL	6

## Ampicillin Sodium Salt

Cat. No.	Description	Storage	Expires	Size	Qty/Pk
61-238-RH	Ampicillin Sodium Salt	2 to 8°C	≥12 m	10 g	1
61-238-RM	Ampicillin Sodium Salt	2 to 8°C	≥12 m	100 g	1

## Antibiotic-Antimycotic Solution

Cat. No.	Description	Storage	Expires	Size	Qty/Pk
30-004-CI	10,000 I.U. Penicillin (per mL), 10,000 µg/mL Streptomycin, 25 µg/mL Amphotericin with 8.5 g/L NaCl	-25 to -15°C	18 m	100 mL	6

## Blasticidin S HCl

### Powder

Cat. No.	Description	Storage	Expires	Size	Qty/Pk
30-100-RB	Blasticidin S HCl, Powder	-25 to -15°C	18 m	50 mL	5

## Chloramphenicol

### Powder

Cat. No.	Description	Storage	Expires	Size	Qty/Pk
61-239-RI	Chloramphenicol	15 to 25°C	≥12 m	25 g	1

## Ciprofloxacin Hydrochloride

### Powder

Cat. No.	Description	Storage	Expires	Size	Qty/Pk
61-277-RF	Ciprofloxacin Hydrochloride	15 to 25°C	≥12 m	1 g	1
61-277-RG	Ciprofloxacin Hydrochloride	15 to 25°C	≥12 m	5 g	1

## G418 Sulfate

### Liquid

Cat. No.	Description	Storage	Expires	Size	Qty/Pk
30-234-CR	G418 Sulfate, 50 mg/mL solution	2 to 8°C	≥12 m	20 mL	1
30-234-CI	G418 Sulfate, 50 mg/mL solution	2 to 8°C	≥12 m	100 mL	1

### Powder

Cat. No.	Description	Storage	Expires	Size	Qty/Pk
61-234-RF	G418 Sulfate, potency >700 µg/mg	15 to 30°C	≥12 m	1 g	1
61-234-RG	G418 Sulfate, potency >700 µg/mg	15 to 30°C	≥12 m	5 g	1
61-234-RK	G418 Sulfate, potency >700 µg/mg	15 to 30°C	≥12 m	50 kg	1

**Gentamicin Sulfate****Liquid** 

Cat. No.	Description	Storage	Expires	Size	Qty/Pk
30-005-CR	Gentamicin Sulfate	15 to 30°C	12 m	10 mL	1

**Powder** 

Cat. No.	Description	Storage	Expires	Size	Qty/Pk
61-098-RA	Gentamicin Sulfate	2 to 8°C	≥12 m	100 mg	1
61-098-RF	Gentamicin Sulfate	2 to 8°C	≥12 m	1 g	1

**Hygromycin B Solution**

Cat. No.	Description	Storage	Expires	Size	Qty/Pk
30-240-CR	Hygromycin B Solution	2 to 8°C	18 m	10 mL	1

**Kanamycin Sulfate****Liquid** 

Cat. No.	Description	Storage	Expires	Size	Qty/Pk
30-006-CF	Kanamycin Sulfate	-25 to -15°C	18 m	50 mL	6

**Powder** 

Cat. No.	Description	Storage	Expires	Size	Qty/Pk
61-176-RG	Kanamycin Sulfate	15 to 30°C	18 m	5 g	1

**Neomycin Sulfate****Powder** 

Cat. No.	Description	Storage	Expires	Size	Qty/Pk
61-241-RG	Neomycin Sulfate	15 to 30°C	18 m	5 g	1

**Penicillin-Streptomycin Solution**

Cat. No.	Description	Storage	Expires	Size	Qty/Pk
30-001-CI	Penicillin-Streptomycin Solution, 50x	-25 to -15°C	18 m	100 mL	6
30-002-CI	Penicillin-Streptomycin Solution, 100x	-25 to -15°C	18 m	100 mL	6
30-009-CI	Penicillin-Streptomycin Solution, 100x [+] 29.2 mg/mL L-glutamine	-25 to -15°C	12 m	100 mL	6

**Puromycin Dihydrochloride****Powder** 

Cat. No.	Description	Storage	Expires	Size	Qty/Pk
61-385-RA	Puromycin Dihydrochloride	-25 to -15°C	12 m	0.1 g	1

**Streptomycin Sulfate****Powder** 

Cat. No.	Description	Storage	Expires	Size	Qty/Pk
61-088-RM	Streptomycin Sulfate	15 to 30°C	12 m	100 g	1

## Tetracycline Hydrochloride

### Powder

Cat. No.	Description	Storage	Expires	Size	Qty/Pk
61-242-RG	Tetracycline Hydrochloride	15 to 30°C	12 m	5 g	1

## Buffers

### HEPES

#### Liquid

Cat. No.	Description	Storage	Expires	Size	Qty/Pk
25-060-CI	HEPES, 1M solution (238.3 mg/mL)	15 to 30°C	24 m	100 mL	6

#### Powder

Cat. No.	Description	Storage	Expires	Size	Qty/Pk
61-034-RM	HEPES	15 to 30°C	≥12 m	100 g	1
61-034-RO	HEPES	15 to 30°C	≥12 m	500 g	1
61-034-RR	HEPES	15 to 30°C	≥12 m	1 kg	1

### Sodium Bicarbonate

#### Liquid

Cat. No.	Description	Storage	Expires	Size	Qty/Pk
25-035-CI	Sodium Bicarbonate, 7.5% solution	15 to 30°C	36 m	100 mL	6

#### Powder

Cat. No.	Description	Storage	Expires	Size	Qty/Pk
61-065-RO	Sodium Bicarbonate	15 to 30°C	≥12 m	500 g	1
61-065-RR	Sodium Bicarbonate	15 to 30°C	≥12 m	1 kg	1

## Enzymatic Cell Dissociation Agents

### Trypsin

Cat. No.	Description	Storage	Expires	Size	Qty/Pk
25-050-CI	0.25% Trypsin in HBSS; [-] calcium, magnesium	-25 to -15°C	12 m	100 mL	6
25-051-CI	0.05% Trypsin/0.53 mM EDTA in HBSS; [+] sodium bicarbonate, [-] calcium, magnesium	-25 to -15°C	12 m	100 mL	6
25-052-CI	0.05% Trypsin/0.53 mM EDTA in HBSS; [-] sodium bicarbonate, calcium, magnesium	-25 to -15°C	12 m	100 mL	6
25-052-CV	0.05% Trypsin/0.53 mM EDTA in HBSS; [-] sodium bicarbonate, calcium, magnesium	-25 to -15°C	12 m	500 mL	6
25-053-CI	0.25% Trypsin/2.21 mM EDTA in HBSS; [-] sodium bicarbonate, calcium, magnesium	-25 to -15°C	12 m	100 mL	6
25-054-CI	2.5% Trypsin in HBSS; [-] calcium, magnesium, phenol red	-25 to -15°C	12 m	100 mL	6

## Non-Enzymatic Cell Dissociation Agents

### Cellstripper® Solution

Cellstripper Solution is a non-enzymatic cell dissociation solution formulated with a proprietary mixture of chelators that gently dislodge adherent cells in tissue culture. It is an alternative to trypsin when used with either serum-free or serum-supplemented media. Because Cellstripper Solution is a gentler reagent than trypsin, cells can be exposed to Cellstripper Solution for longer periods of time. Cellstripper Solution achieves superior results in comparison to enzymatic dissociation products.

Cat. No.	Description	Storage	Expires	Size	Qty/Pk
25-056-CI	Cellstripper Solution	15 to 30°C	12 m	100 mL	6

## Growth Supplements

### ITS (Insulin, Transferrin, Selenium)

Cat. No.	Description	Storage	Expires	Size	Qty/Pk
25-800-CR	ITS, 100x	2 to 8°C	18 m	10 mL	1

## Hybridoma Reagents

### HAT (Hypoxanthine, Aminopterin, Thymidine)

Cat. No.	Description	Storage	Expires	Size	Qty/Pk
25-046-CI	HAT (Hypoxanthine, Aminopterin, Thymidine), 50x	-25 to -15°C	28 m	100 mL	1

### HT (Hypoxanthine, Thymidine)

Cat. No.	Description	Storage	Expires	Size	Qty/Pk
25-047-CI	HT (Hypoxanthine, Thymidine), 50X	2 to 8°C	20 m	100 mL	1

## Miscellaneous Reagents

### DMSO (Dimethyl Sulfoxide)

Cat. No.	Description	Storage	Expires	Size	Qty/Pk
25-950-CQC	DMSO (Dimethyl Sulfoxide)	15 to 30°C	12 m	250 mL	1

### 45% Glucose Solution

Cat. No.	Description	Storage	Expires	Size	Qty/Pk
25-037-CIR	45% Glucose Solution	15 to 30°C	24 m	100 mL	1

### Sodium Pyruvate

Cat. No.	Description	Storage	Expires	Size	Qty/Pk
25-000-CIR	100 mM Solution with 8.5 g/L NaCl	2 to 8°C	18 m	100 mL	6

## Trace Elements

### Trace Elements A

Trace Elements A provides copper, zinc, iron and selenium. Selenium aids in the detoxification of free radicals as a cofactor for GSH synthetase, while iron, copper, and zinc may be bound by serum protein. The combination of Trace Elements A and B contains the trace elements of MCDB 104.

Cat. No.	Description	Storage	Expires	Size	Qty/Pk
25-021-CI	Trace Elements A, 1000x solution	15 to 30°C	*	100 mL	1

\* Please inquire for lot-specific expiration dates or view the current certificate of analysis at [www.corning.com/lifesciences/media](http://www.corning.com/lifesciences/media)

### Trace Elements B

Trace Elements B has the same composition as Cleveland's Trace Elements I. The combination of Trace Elements A, B and C contains the trace elements of MCDB 301.

Cat. No.	Description	Storage	Expires	Size	Qty/Pk
25-022-CI	Trace Elements B, 1000x solution	2 to 8°C	*	100 mL	1

\* Please inquire for lot-specific expiration dates or view the current certificate of analysis at [www.corning.com/lifesciences/media](http://www.corning.com/lifesciences/media)

### Trace Elements C

Trace Elements C has the same composition of Cleveland's Trace Elements II, and the combination of Trace Elements A, B and C contains the trace elements of MCDB 301.

Cat. No.	Description	Storage	Expires	Size	Qty/Pk
25-023-CI	Trace Elements C, 1000x solution	2 to 8°C	*	100 mL	1

\* Please inquire for lot-specific expiration dates or view the current certificate of analysis at [www.corning.com/lifesciences/media](http://www.corning.com/lifesciences/media)

## Trypan Blue Solution

Cat. No.	Description	Storage	Expires	Size	Qty/Pk
25-900-CI	Trypan Blue Solution, 0.4% (w/v) in PBS, pH 7.5 ± 0.5	15 to 30°C	24 m	100 mL	1



# 6 Microbiology and Molecular Biology

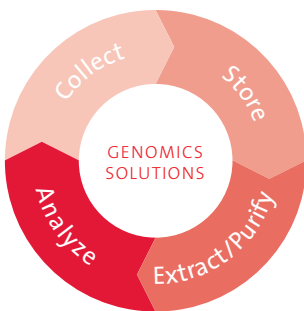

Our molecular biology product line ranges from microbiological media and components to molecular reagents and buffers. With a wide range of antibiotics to choose from, these products allow you to select your growth as well as ensure their viability and proliferation. Many of the antibiotics offered are members of the aminoglycoside family whose mechanism of action works by binding to the 30S ribosomal subunit.



**Miller's LB Broth**

Cat. No.	Description	Storage	Expires	Size	Qty/Pk
46-050-CM	Miller's LB Broth	15 to 30°C	*	1L	6

\* Please inquire for lot-specific expiration dates or view the current certificate of analysis at [www.corning.com/lifesciences/media](http://www.corning.com/lifesciences/media)

**S.O.C. Medium**

Cat. No.	Description	Storage	Expires	Size	Qty/Pk
46-003-CR	S.O.C. Medium	15 to 30°C	12 m	10 mL	10

**Terrific Broth**

Cat. No.	Description	Storage	Expires	Size	Qty/Pk
46-055-CM	Terrific Broth	15 to 30°C	12 m	1L	6

**Ampicillin Sodium Salt**

Powder ☼

Cat. No.	Description	Storage	Expires	Size	Qty/Pk
61-238-RH	Ampicillin Sodium Salt	2 to 8°C	24-30 m	10 g	1
61-238-RM	Ampicillin Sodium Salt	2 to 8°C	24-30 m	100 g	1

**Carbenicillin Disodium Salt**

Cat. No.	Description	Storage	Expires	Size	Qty/Pk
46-100-RG	Carbenicillin Disodium Salt	2 to 8°C	24-30 m	5 g	1

**Kanamycin Sulfate**

Liquid 💧

Cat. No.	Description	Storage	Expires	Size	Qty/Pk
30-006-CF	Kanamycin Sulfate	-25 to -15°C	12 m	50 mL	6

Powder ☼

Cat. No.	Description	Storage	Expires	Size	Qty/Pk
61-176-RG	Kanamycin Sulfate	15 to 30°C	≥12 m	5 g	1

**Neomycin Sulfate**

Cat. No.	Description	Storage	Expires	Size	Qty/Pk
61-241-RG	Neomycin Sulfate	15 to 30°C	12 m	5 g	1

**Streptomycin Sulfate**

Cat. No.	Description	Storage	Expires	Size	Qty/Pk
61-088-RM	Streptomycin Sulfate	2 to 8°C	12 m	100 g	1

**Tetracycline Hydrochloride**

Powder ☼

Cat. No.	Description	Storage	Expires	Size	Qty/Pk
61-242-RG	Tetracycline Hydrochloride, powder	2 to 8°C	12 m	5 g	1

**X-Gal**

Powder ☼

Cat. No.	Description	Storage	Expires	Size	Qty/Pk
46-101-RF	X-Gal	-25 to -15°C	24 m	1 g	1

**IPTG (Isopropylthiogalactoside)**

Powder ☼

Cat. No.	Description	Storage	Expires	Size	Qty/Pk
46-102-RF	IPTG (Isopropylthiogalactoside)	-25 to -15°C	36 m	1 g	1

## Buffers

### MOPS Buffer

Cat. No.	Description	Storage	Expires	Size	Qty/Pk
46-103-RM	MOPS Buffer, pH 6.5-7.9	15 to 30°C	*	100 g	1

\* Please inquire for lot-specific expiration dates or view the current certificate of analysis at [www.corning.com/lifesciences/media](http://www.corning.com/lifesciences/media)

### PBS (Phosphate Buffered Saline), 10x

Cat. No.	Description	Storage	Expires	Size	Qty/Pk
46-013-CM	[−] Calcium, magnesium, pH 7.4 ± 0.1, DNase/RNase and protease free	15 to 30°C	24 m	1L	6

### SSC Buffer, 20x

Cat. No.	Description	Storage	Expires	Size	Qty/Pk
46-020-CM	pH 7.0 ± 0.1, DNase/RNase and protease free	15 to 30°C	24 m	1L	6

### SSPE Buffer, 20x

Cat. No.	Description	Storage	Expires	Size	Qty/Pk
46-021-CM	pH 7.4 ± 0.1, DNase/RNase and protease free	15 to 30°C	18 m	1L	6

### TAE Buffer, 10x

Cat. No.	Description	Storage	Expires	Size	Qty/Pk
46-010-CM	pH 8.3 ± 0.1, DNase/RNase and protease free	15 to 30°C	24 m	1L	6

### TBE Buffer, 10x

Cat. No.	Description	Storage	Expires	Size	Qty/Pk
46-011-CM	pH 8.4 ± 0.1, DNase/RNase and protease free	15 to 30°C	24 m	1L	6

### TSB (Tryptic Soy Broth)

#### Liquid

Cat. No.	Description	Storage	Expires	Size	Qty/Pk
46-060-CI	Tryptic Soy Broth, animal free	15 to 30°C	12 m	100 mL	1
46-060-CM	Tryptic Soy Broth, animal free	15 to 30°C	12 m	1L	1
 46-060-LB	Tryptic Soy Broth, animal free	15 to 30°C	12 m	20L	1

#### Powder

Cat. No.	Description	Storage	Expires	Size	Qty/Pk
61-411-RO	Tryptic Soy Broth, animal free	15 to 30°C	12 m	500 g	1

### Tris Base Buffer

#### Powder

Cat. No.	Description	Storage	Expires	Size	Qty/Pk
61-233-RM	Tris Base Buffer	15 to 30°C	≥12 m	100 g	1
61-233-RR	Tris Base Buffer	15 to 30°C	≥12 m	1 kg	1
61-233-RT	Tris Base Buffer	15 to 30°C	≥12 m	5 kg	1

### Yeast Extract

#### Powder

Cat. No.	Description	Storage	Expires	Size	Qty/Pk
61-231-RO	Yeast Extract	15 to 30°C	20 m	500 g	1

**TE Buffer, 1x**

Cat. No.	Description	Storage	Expires	Size	Qty/Pk
46-009-CM	pH 7.9-8.1, DNase/RNase and protease free	15 to 30°C	12 m	1L	6

**Tris Buffered Saline, 10x**

Cat. No.	Description	Storage	Expires	Size	Qty/Pk
46-012-CM	pH 7.4 ± 0.1, DDNase/RNase and protease free	15 to 30°C	12 m	1L	6

**Tris-HCl Buffers, 1M**

Cat. No.	Description	Storage	Expires	Size	Qty/Pk
46-030-CM	pH 7.5 ± 0.1, DNase/RNase and protease free	15 to 30°C	24 m	1L	6
46-031-CM	pH 8.0 ± 1.0, DNase/RNase and protease free	15 to 30°C	24 m	1L	6

**Reagents****EDTA, 0.5M**

Cat. No.	Description	Storage	Expires	Size	Qty/Pk
46-034-CI	EDTA, 0.5M, pH 8.0	15 to 30°C	24 m	100 mL	1

**SDS (Sodium Dodecyl Sulfate), 10%**

Cat. No.	Description	Storage	Expires	Size	Qty/Pk
46-040-CI	SDS (Sodium Dodecyl Sulfate), 10%	15 to 30°C	24 m	100 mL	1

**Sodium Acetate, 3M**

Cat. No.	Description	Storage	Expires	Size	Qty/Pk
46-033-CI	Sodium Acetate, 3M, pH 5.2 ± 0.1	15 to 30°C	24 m	100 mL	1

**Sodium Chloride, 5M**

Cat. No.	Description	Storage	Expires	Size	Qty/Pk
46-032-CV	Sodium Chloride, 5M	15 to 30°C	24 m	500 mL	6

# 7 High Quality Water

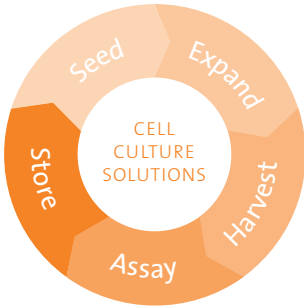

Corning® High Quality Water is manufactured in our Mediatech, Inc. FDA-registered facility in accordance with a comprehensive quality system that's compliant with cGMP and current ISO 13485 guidelines.

Corning offers a range of high quality water products for small and large volume requirements. These products eliminate the expense of installing and maintaining your own water system, and ensure you have a secondary source of water that meets your specifications.

Corning High-Quality water is available in a variety of sizes, and tested against specifications which may include USP and EP monograph requirements.



## HIGH QUALITY WATER

### Water, WFI Quality

WFI quality water tested to USP specifications.

Cat. No.	Description	Storage	Expires	Size	Qty/Pk
25-055-CI	Water, WFI Quality	15 to 30°C	36 m	100 mL	6
25-055-CV	Water, WFI Quality	15 to 30°C	36 m	500 mL	6
<b>New</b> 25-055-CVC	Water, WFI Quality, with septum cap	15 to 30°C	36 m	500 mL	6
25-055-CM	Water, WFI Quality	15 to 30°C	36 m	1L	6
25-055-LB	Water, WFI Quality	15 to 30°C	36 m	20L	1
25-055-LG	Water, WFI Quality	15 to 30°C	36 m	100L	1
25-055-LH	Water, WFI Quality	15 to 30°C	36 m	200L	1

### Water, WFI Quality

WFI quality water tested to USP and EP specifications.

Cat. No.	Description	Storage	Expires	Size	Qty/Pk
25-065-LB	Water, WFI Quality	15 to 30°C	36 m	20L	1
25-065-LG	Water, WFI Quality	15 to 30°C	36 m	100L	1
25-065-LH	Water, WFI Quality	15 to 30°C	36 m	200L	1

### Molecular Biology Grade Water

Cat. No.	Description	Storage	Expires	Size	Qty/Pk
46-000-CI	Molecular Biology Grade Water	15 to 30°C	24 m	100 mL	6
<b>New</b> 46-000-CV	Molecular Biology Grade Water	15 to 30°C	24 m	500 mL	6
<b>New</b> 46-000-CM	Molecular Biology Grade Water	15 to 30°C	24 m	1L	6

### Reagent Grade Water

Cat. No.	Description	Storage	Expires	Size	Qty/Pk
<b>New</b> 46-002-LF	Reagent Grade Water	15 to 30°C	*	4L	2

\* Please inquire for lot-specific expiration dates or view the current certificate of analysis at [www.corning.com/lifesciences/media](http://www.corning.com/lifesciences/media)

# 8 Flexible Packaging Systems

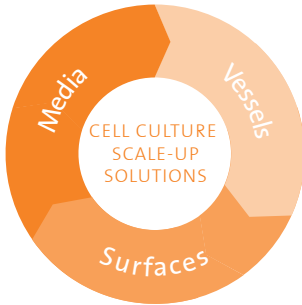

Corning® flexible packaging systems are available in multiple formats including custom configurations to meet your exact requirements. Our single-use bags are designed to be practical and cost-effective alternatives to rigid-walled containers. They are fabricated to match your specific application with a variety of bag sizes and tubing/connector configurations available. These containment and delivery systems preserve the physical, chemical, and functional characteristics of sterile fluids.

## Features and Benefits

- ▶ High-quality barrier films
- ▶ Gamma irradiated
- ▶ Gas and moisture barriers to minimize transmission of oxygen, carbon dioxide and water vapor
- ▶ Universal connection systems
- ▶ Eliminates costs associated with washing, sterilization, and SIP/CIP validations
- ▶ Eliminates the risks associated with cross-contamination
- ▶ Minimal setup time
- ▶ Wide variety of standard configurations
- ▶ Easily integrated in automated systems

## Industry Recognized Manufacturing Standards

- ▶ cGMP, ISO-certified manufacturing process
- ▶ Complete documentation and traceability



Collection Containers

Corning® collection containers are available in 2D hanging configurations and multiple bag volumes with multiple connector configurations.

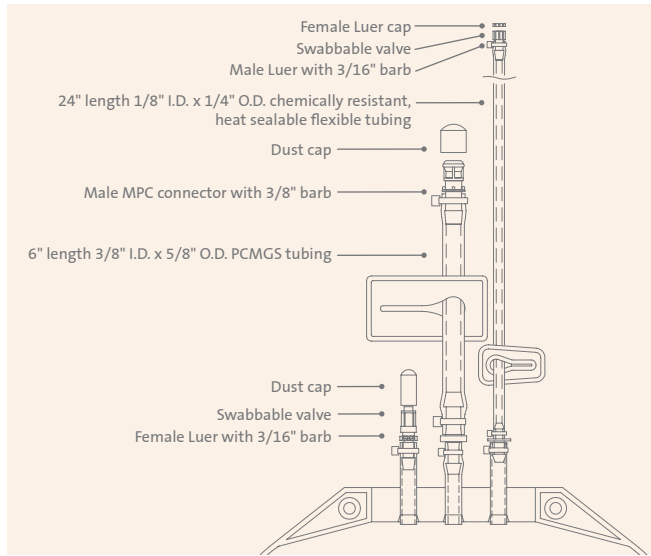

Cat. No.	Film Type	Size	Qty
91-200-01	EVA	1L	1
91-200-02	EVA	2L	1
91-200-05	EVA	5L	1
91-200-10	EVA	10L	1
91-200-20	EVA	20L	1

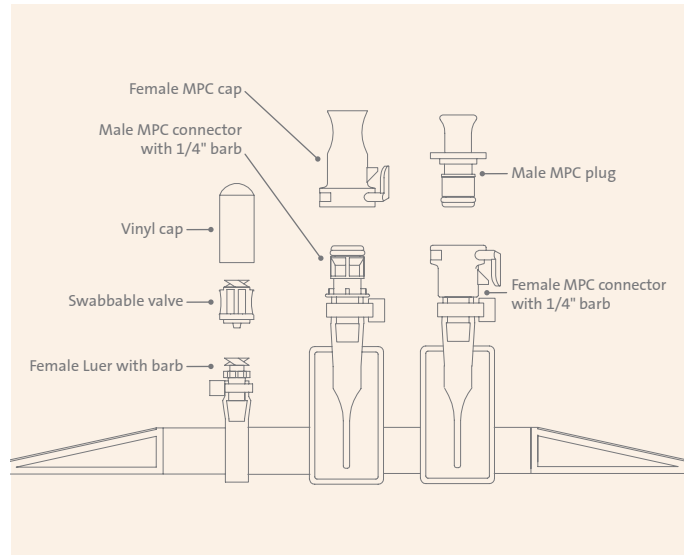

Cat. No.	Film Type	Size	Qty
91-200-36	EVA	10L	1
91-200-39	EVA	20L	1

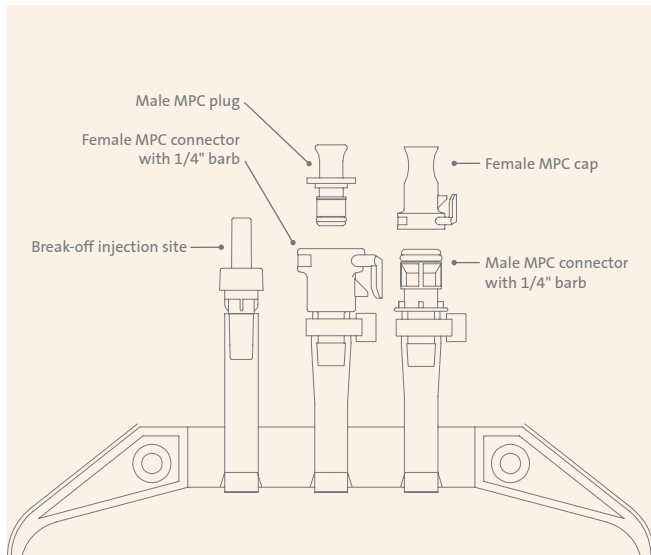

Cat. No.	Film Type	Size	Qty
91-200-41	EVA	500 mL	1
91-200-42	EVA	1L	1

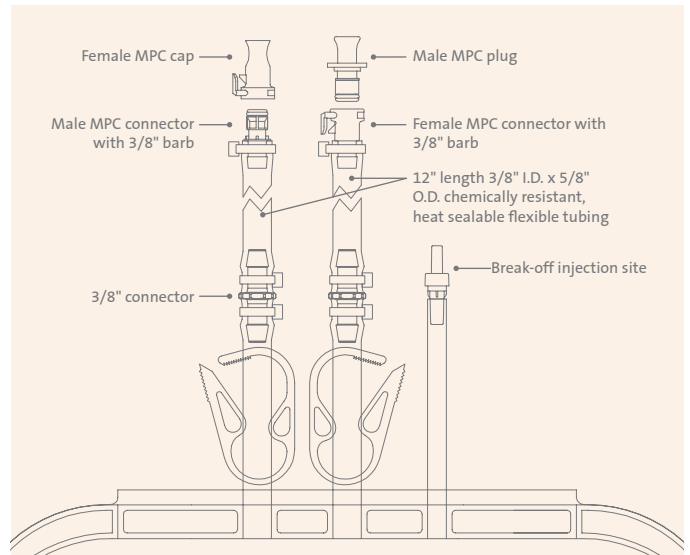

Cat. No.	Film Type	Size	Qty
91-200-43	EVA	5L	1
91-200-45	EVA	10L	1
91-200-47	EVA	20L	1
91-200-48	EVA	50L	1

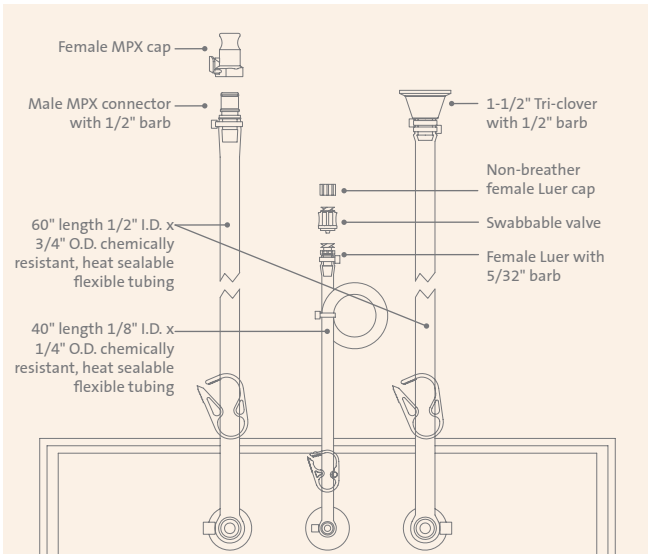

Cat. No.	Film Type	Size	Qty
91-200-82	ULDPE	100L	1
91-200-83	ULDPE	200L	1

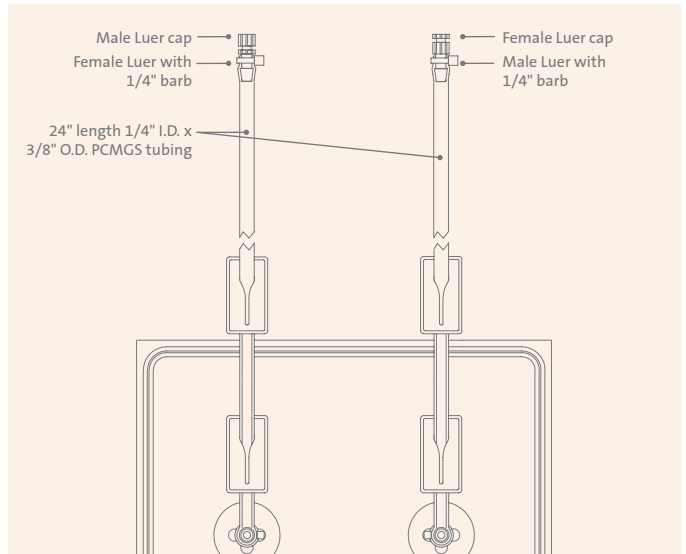

Cat. No.	Film Type	Size	Qty
91-002-MX	Metallocene	10L	1
91-001-MB	Metallocene	25L	1

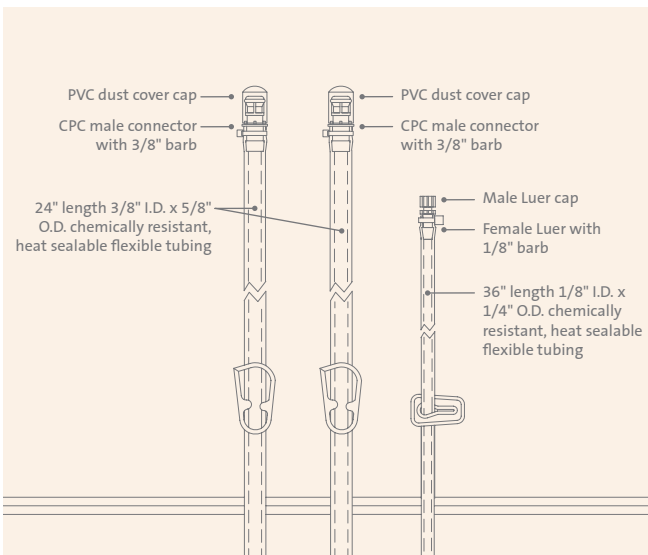

Cat. No.	Film Type	Size	Qty
91-100-30	Metallocene	50L	1
91-100-35	Metallocene	100L	1

## Cell Expansion Bags

Cell expansion bags are intended for the expansion and culture of non-adherent cells. The container is made from a single-web polyolefin, gas permeable film. The integrated tubing allows for functionally closed system filling, feeding and sampling.

### Features and Benefits

- ▶ Cell expansion observed with multiple cell models
- ▶ Gas permeable film
- ▶ Reusable sampling valve for in process testing
- ▶ Tubing for sterile weld connections
- ▶ Scalable, user friendly design

### Technical Information

Biocompatibility Tests	Result	Test Protocol
USP Class VI	Pass	USP <88>
Cytotoxicity	Non-cytotoxic	ISO 10993-1
Bacterial endotoxin	Pass	USP <85>
Heavy metals	<2 ppm	ISO 3826-1
Buffering capacity	1.22 mL	USP <661>
Non-volatile residue	8.6 mg	USP <661>
Residue on ignition (polyolefins)	<1 mg	ISO 3826-1
Acidity and alkalinity	Pass	ISO 3826-1
Oxidizable constituents	<1.5 mL	ISO 3826-1
Absorbance	<0.2 abs unit	ISO 3826-1
Reducing substances	0.34 mL	EP 3.1.14
Local effects after implantation	Pass	ISO 10993-6
Irritation and delayed-type sensitivity	Pass	ISO 10993-10
Systemic toxicity	Pass	ISO 10993-11

Physical Properties	Result	Test Protocol
O <sub>2</sub> transmission (cm <sup>3</sup> /100 in <sup>2</sup> /24 hrs) @ (25°C; 0% RH)	153	ASTM D-3985
CO <sub>2</sub> transmission (cm <sup>3</sup> /100 in <sup>2</sup> /24 hrs) @ (25°C; 0% RH)	1183	MOCON Test Method
Moisture vapor transmission (g/100 in <sup>2</sup> /24 hrs)	0.94	ASTM D-1249
Transmittance (%)	83	ASTM D-1003
Tensile strength (psi)	3400/3700	ASTM D-638
Elastic modulus (E)	540/480	ASTM D-638

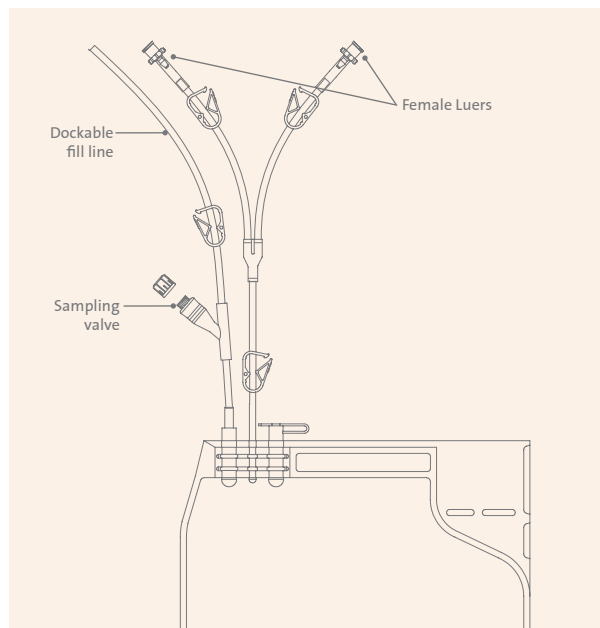

Cat. No.	Size	Fill Volume	Qty
91-200-84	500 mL	190 mL	1
91-200-85	1L	381 mL	1
91-200-86	3 L	633 mL	1
91-200-87	5L	1252 mL	1

## Cryopreservation Bags

Cryogenic storage containers are designed for storage, preservation and transfer of cells.

### Design Offers

- ▶ Unique bag film material remains flexible at ultra-low temperatures (-196°C).
- ▶ Proprietary membrane port design offers thinner walls for increased flexibility and attached cap minimizes membrane exposure during freezing
- ▶ Industry standard label pocket design offers ease-of-use and traceability in labeling

### Features and Benefits

- ▶ Polyolefin film – Proprietary EVA blend specifically selected for its low temperature properties while maintaining flexibility and clarity when filled with liquid
- ▶ Membrane port – The attached cap snaps into place to protect the contents and minimizes membrane exposure during use
- ▶ Label pocket – Supports use of computer-generated labels; critical information can be viewed quickly by simply opening the freezing cassette
- ▶ Integral fill tube – The unique manufacturing method used to secure the fill tube to the container body eliminates the need for PVC interfaces with the liquid nitrogen storage section of the container
- ▶ Interface/Connectors – Compatible with sterile connection technology and smart seal technology (Sebra® Model 1100 tube welder); fits in a variety of freezing cassette systems

### Physical Integrity

The physical integrity of the containers were evaluated for their ability to withstand temperature variations experienced during routine storage of hematopoietic progenitor cell products. All containers passed the physical integrity tests performed, which included the initial pressure test and leak tests and the microbial challenge and dye immersion tests.

### Cell Quality

Cell quality was assessed on our cryogenic storage containers using diluted HPC with 10% DMSO. All containers met the acceptance requirement for MNC and CD34+ cell recovery of ≥70% relative to cell counts of the sample prior to cryopreservation. The average MNC and CD34+ cell recoveries were 81% and 84%, respectively. All containers met ≥ 1 CFU acceptance criteria with an average of 78% recovery.

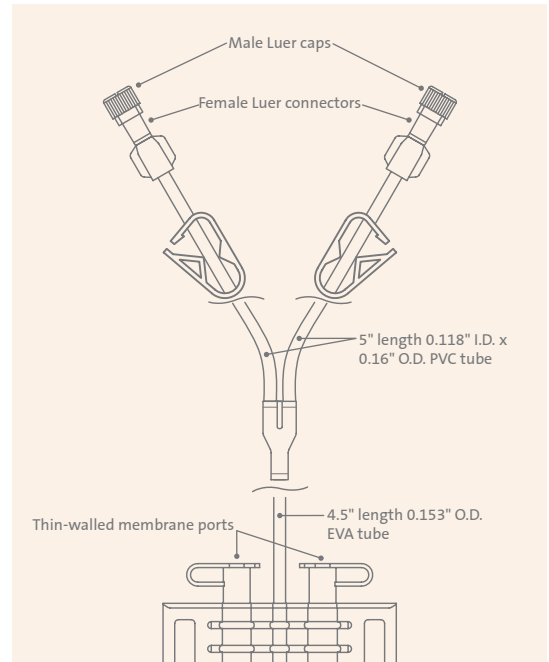

Cat. No.	Size	Fill Volume
91-200-88	50 mL	10-20 mL
91-200-89	250 mL	30-70 mL
91-200-90	500 mL	55-100 mL
91-200-91	750 mL	80-190 mL

### Rocker Cell Culture Bags

Rocker cell culture bags are designed for use with commercial rocking-motion bioreactor chambers, and feature irradiated ethylene vinyl acetate/low-density polyethylene film and stability bars on each side allow. This single-use cell culture bag is ideal for basic research to large-scale biopharmaceutical manufacturing applications.

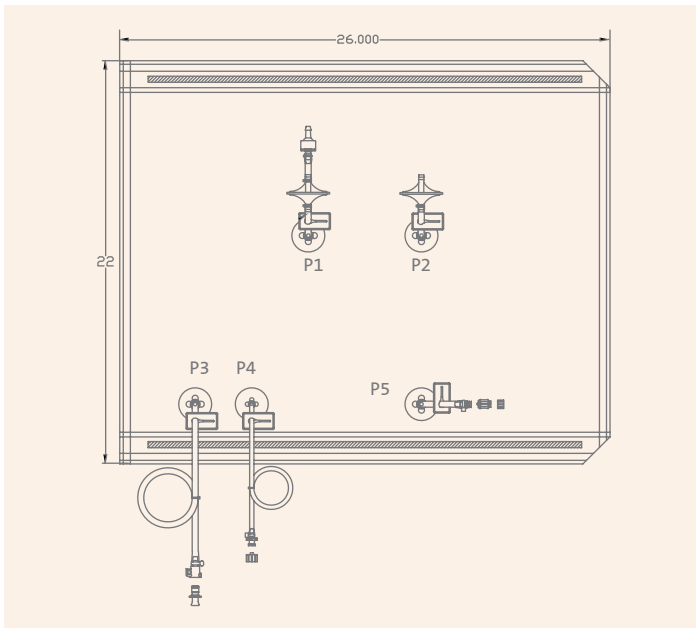

Cat. No.	Size	Qty
91-200-78	20L	1
P1	Check valve with 1/4" barb Pall 8004022 filter 2" length 3/16" I.D. x 3/8" O.D. PCMGS tube	
P2	Pall 8004022 filter 2" length 3/16" I.D. x 3/8" O.D. PCMGS tube	
P3	Female MPC connector with 1/4" barb Male MPC plug 40" length 1/4" I.D. x 7/16" O.D. chemically resistant, heat sealable flexible tube	
P4	Female Luer with 1/4" barb Male Luer plug 40" length 1/8" I.D. x 1/4" O.D. chemically resistant, heat sealable flexible tube	
P5	Female Luer with 1/4" barb Swabbable valve Male Luer plug without stem	

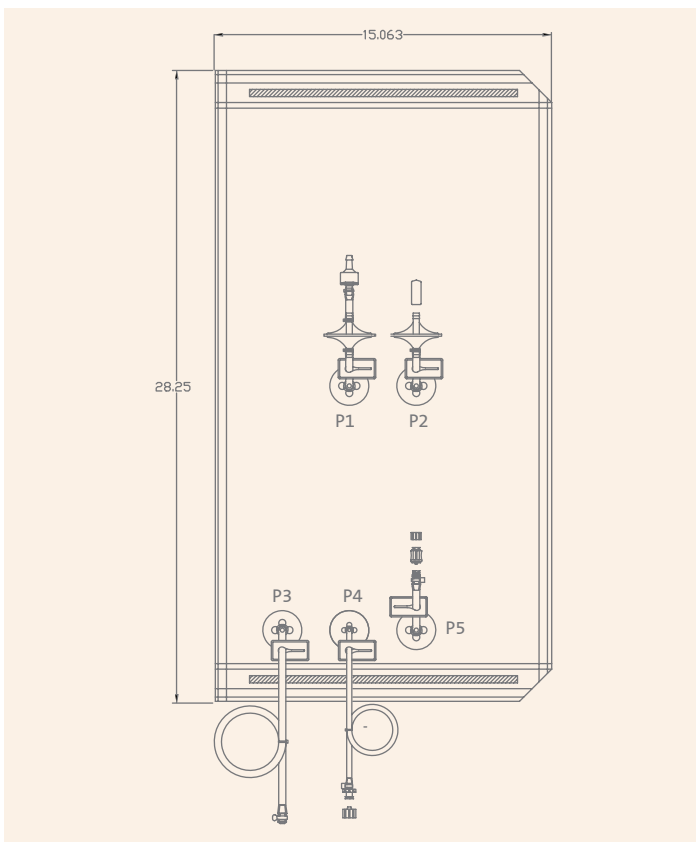

Cat. No.	Size	Qty
91-200-92	22L	1
P1	Check valve with 1/4" barb Pall 8004022 filter 2" length 3/16" I.D. x 3/8" O.D. PCMGS tube	
P2	Pall 8004022 filter 2" length 3/16" I.D. x 3/8" O.D. PCMGS tube	
P3	Female MPC connector with 1/4" barb Male MPC plug 40" length 1/4" I.D. x 7/16" O.D. chemically resistant, heat sealable flexible tube	
P4	Female Luer with 1/4" barb Male Luer plug 40" length 1/8" I.D. x 1/4" O.D. chemically resistant, heat sealable flexible tube	
P5	Female Luer with 1/4" barb Swabbable valve Male Luer plug without stem	

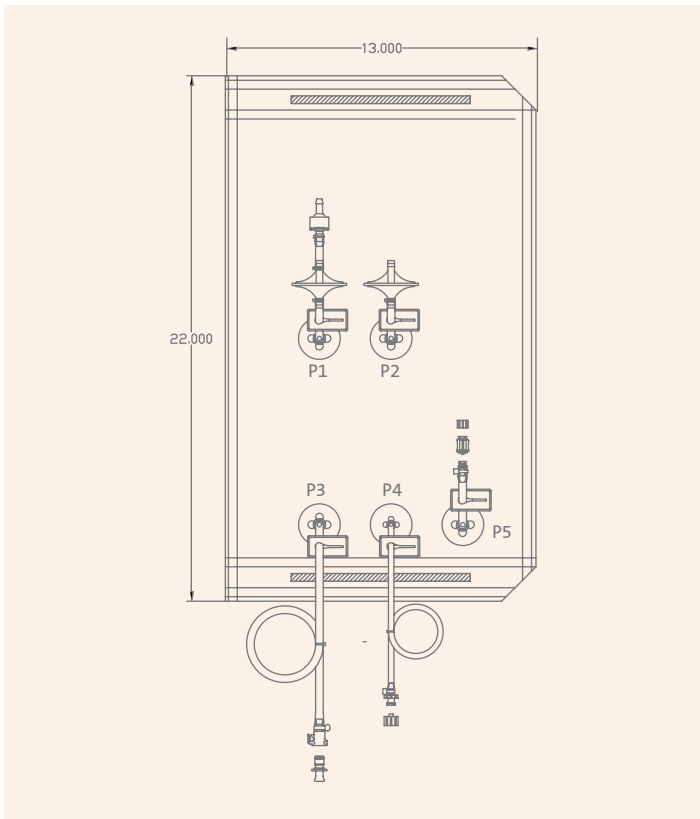

Cat. No.	Size	Qty
91-200-79	10L	1
P1	Check valve with 1/4" barb Pall 8004022 filter 2" length 3/16" I.D. x 3/8" O.D. PCMGS tube	
P2	Pall 8004022 filter 2" length 3/16" I.D. x 3/8" O.D. PCMGS tube	
P3	Female MPC connector with 1/4" barb and plug 40" length 1/4" I.D. x 7/16" O.D. chemically resistant, heat sealable flexible tube	
P4	Female Luer with 1/4" barb and plug 40" length 1/8" I.D. x 1/4" O.D. chemically resistant, heat sealable flexible tube	
P5	Female Luer with 1/4" barb Swabbable valve Male Luer plug without stem	

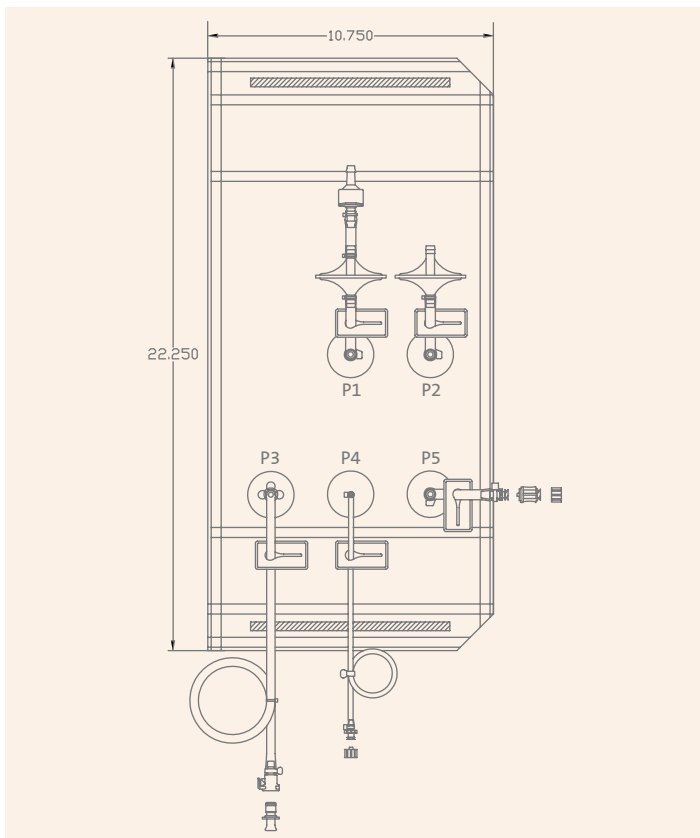

Cat. No.	Size	Qty
91-200-80	2L	1
P1	Check valve with 1/4" barb Pall 8004022 filter 2" length 3/16" I.D. x 3/8" O.D. PCMGS tube	
P2	Pall 8004022 filter 2" length 3/16" I.D. x 3/8" O.D. PCMGS tube	
P3	Female MPC connector with 1/4" barb Male MPC plug 40" length 1/4" I.D. x 7/16" O.D. chemically resistant, heat sealable flexible tube	
P4	Female Luer with 1/4" barb Male Luer plug 40" length 1/8" I.D. x 1/4" O.D. chemically resistant, heat sealable flexible tube	
P5	Female Luer with 1/4" barb Swabbable valve Male Luer plug without stem	

Rocker Cell Culture Bags (continued)

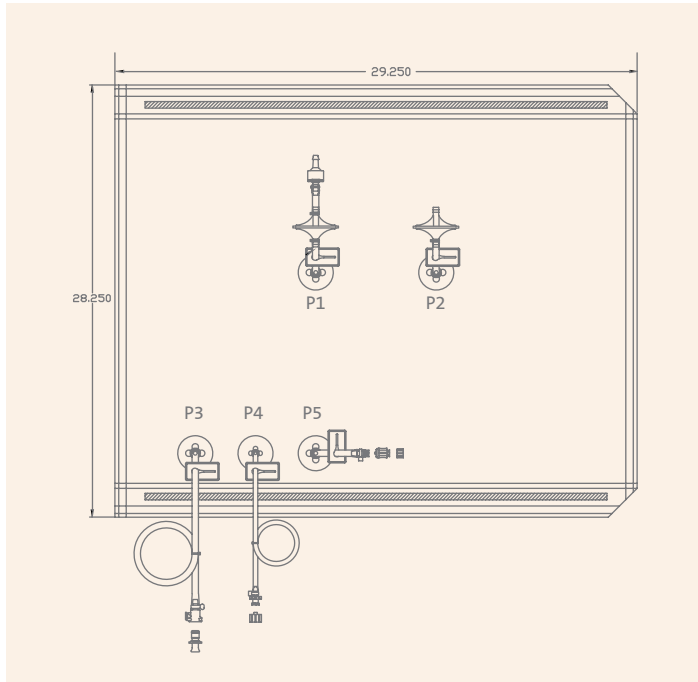

Cat. No.	Size	Qty
91-200-81	50L	1
P1	Check valve with 1/4" barb Pall 8004022 filter 2" length 3/16" I.D. x 3/8" O.D. PCMGS tube	
P2	Pall 8004022 filter 2" length 3/16" I.D. x 3/8" O.D. PCMGS tube	
P3	Female MPC connector with 1/4" barb Male MPC plug 40" length 1/4" I.D. x 7/16" O.D. chemically resistant, heat sealable flexible tubing	
P4	Female Luer with 1/4" barb Male Luer plug 40" length 1/8" I.D. x 1/4" O.D. chemically resistant, heat sealable flexible tubing	
P5	Female Luer with 1/4" barb Swabbable valve Male Luer plug without stem	

Tubing Sets

Optional tubing sets are available in combination with all single-use bag options.

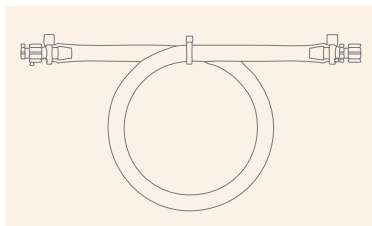

Cat. No.	Description	Qty
91-700-00	36" length 1/4" I.D. clear chemically resistant, heat sealable, flexible tubing Male Luer and female Luer cap Female Luer and male Luer cap	1

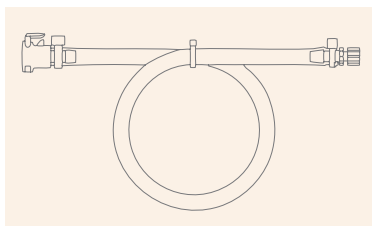

Cat. No.	Description	Qty
91-700-04	36" length 1/4" I.D. clear chemically resistant, heat sealable, flexible tubing Female MPC connector Female Luer and male Luer cap	1

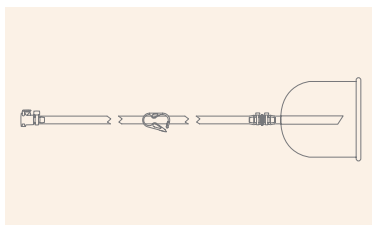

Cat. No.	Description	Qty
91-700-12	24" length 1/4" I.D. clear chemically resistant, heat sealable, flexible tubing Female MPC connector with 1/4" barb Pinch clamp Filling bell	1

### Single-use Bags for Corning® HYPERStack® Vessels

These single-use bags can be connected to tubing via tube welding or by using the pre-assembled multipurpose connectors. They can be used to add media, trypsin, or quenching substrates to complete cell culture in an entirely closed solution.

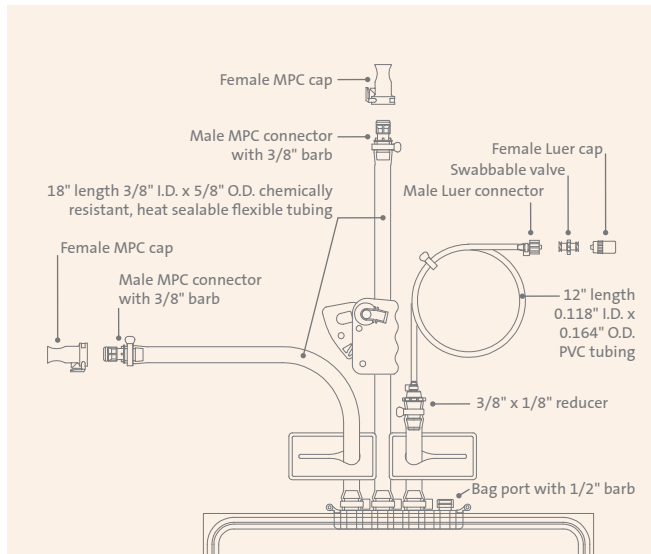

Cat. No.	Description	Film Type	Size	Qty
91-200-75	Trypsin bag	ULDPE	5L	1

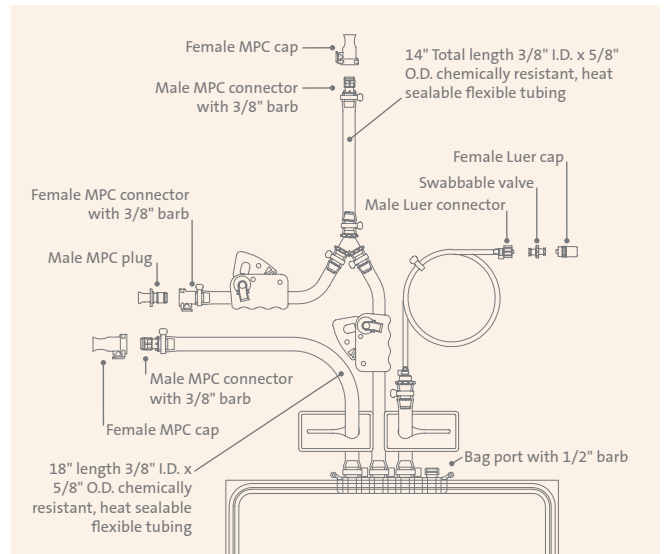

Cat. No.	Description	Film Type	Size	Qty
91-200-76	Quench bag	ULDPE	5L	1

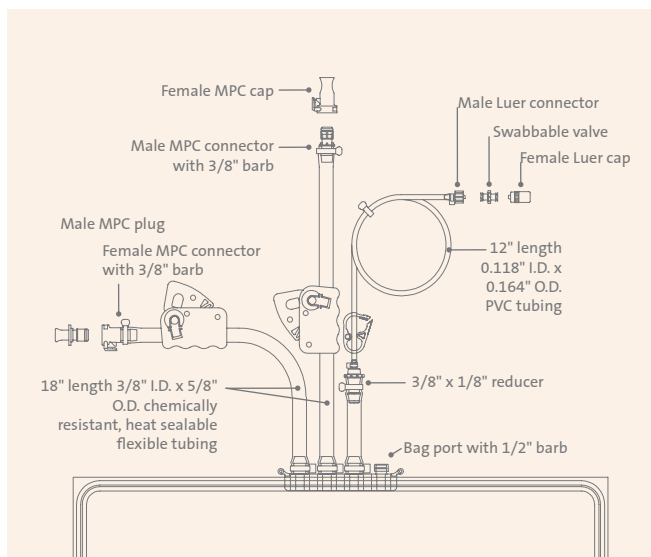

Cat. No.	Description	Film Type	Size	Qty
91-200-77	Media bag	ULDPE	20L	1

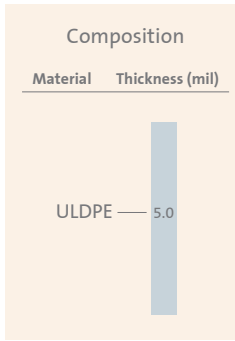

### Tank Liners

Corning’s portfolio of irradiated tank liners are designed to fit cylindrical tanks. Tank liners are manufactured with low-density polyethylene (LDPE) and are available in a range of sizes.

#### Features and Benefits

- ▶ Gamma irradiated, individually packaged
- ▶ Free of animal-derived components
- ▶ Eliminate costs associated with the cleaning and validation of tanks
- ▶ Decrease labor costs and increase turnaround time
- ▶ Eliminate the risks associated with cross contamination
- ▶ Help extend the life of reusable tanks, resulting in lower capital expenditures
- ▶ Wide variety of sizes available

#### Technical Information

Biocompatibility Tests	Result	Test Protocol
USP intracutaneous reactivity	Pass	USP <88>
USP acute systemic injection	Pass	USP <88>
USP intramuscular implantation	Pass	USP <88>
USP MEM elution method	Non-cytotoxic	USP <87>
Physiochemical test for plastics	Pass	USP <661>

Physical Properties	Result	Test Protocol
H <sub>2</sub> O transmission (g/100 in <sup>2</sup> /24 hrs)	0.017	ASTM F-1249
CO <sub>2</sub> transmission (cm <sup>3</sup> /100 in <sup>2</sup> /24 hrs)	0.129	ASTM F-2476
O <sub>2</sub> transmission (cm <sup>3</sup> /100 in <sup>2</sup> /24 hrs)	0.043	ASTM F-1927

Test	Result	Test Protocol
Tensile strength	Average force - 32.73 lbs Average MOE - 251110 psi Average Elongation - 1080%	ASTM D 882-02
Tear resistance	Minimum force - 6.77 lbs Average force - 7.21 lbs Maximum force - 7.74 lbs	ASTM D1001-07
Puncture resistance	Minimum force - 16.42 lbs Average force - 18.61 lbs Maximum force - 19.51 lbs	FTMS 101C

#### Gusseted Tank Liners (3D)

Cat. No.	Max. Volume	Diameter	Depth	Qty
91-300-15	50L	13"	~27"	1
91-300-25	100L	18"	~30"	1
91-300-35	200L	22"	~36"	1

#### Non-gusseted Tank Liners (2D)

Cat. No.	Max. Volume	Diameter	Depth	Qty
91-300-20	130L	18"	~30"	1
91-300-30	200L	22.5"	~36"	1
91-300-80	1090L	42"	~49"	1

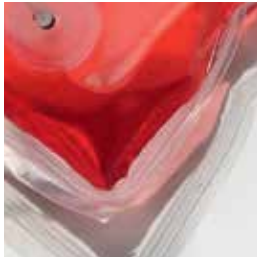

### Film Types

#### Ethyl Vinyl Acetate (EVA) Film

4-layer, 12.5 mil co-extrusion film.

##### Technical Information

Biocompatibility Tests	Result	Test Protocol
USP intracutaneous reactivity test	Pass	USP <88>
USP acute systemic injection test	Pass	USP <88>
USP intramuscular implantation test	Pass	USP <88>
USP MEM elution method	Non-cytotoxic	USP <87>
Hemolysis	Non-hemolytic	ISO 10993-4
Bacterial endotoxin	<0.015 EU/mL	LAL test

Physical Properties	Result	Test Protocol
H <sub>2</sub> O transmission (g/100 in <sup>2</sup> /24 hrs)	0.011	ASTM F-1249
CO <sub>2</sub> transmission (cm <sup>3</sup> /100 in <sup>2</sup> /24 hrs)	0.58	MOCON Test Method
O <sub>2</sub> transmission (cm <sup>3</sup> /100 in <sup>2</sup> /24 hrs)	0.28	ASTM F-3985
Ultimate tensile	3100 psi	ASTM D-638
Ultimate elongation	> 650%	ASTM D-638
100% modulus	1000 psi	ASTM D-638
Tear strength	550lbs/in	ASTM D-1004
Low pressure brittleness	> -75°F	ASTM D-1290
Puncture resistance	22.4 lbs	FTMS 101 B

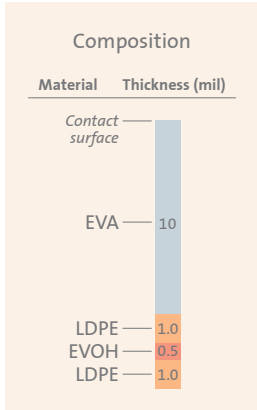

#### Metalocene Film

Single-layer, co-extruded blend of cross-linked polyethylene, EVOH and Nylon.

##### Technical Information

Biocompatibility Tests	Result	Physical Properties	Result
Cytotoxicity	Pass	O <sub>2</sub> transmission rate	0.148 cm <sup>3</sup> /m <sup>2</sup> /24 hours (23°C, 100% R.H. inside and 50% R.H. outside)
Bacterial endotoxin	<0.005 EU/mL	CO <sub>2</sub> transmission rate	<1.0 cm <sup>3</sup> /m <sup>2</sup> /24 hours (23°C, 50% R.H. outside)
Hemolysis	Pass	Water vapor transmission rate	0.455 g/m <sup>2</sup> /24 hours (23°C, 100% R.H.)
Heavy metals	<1 ppm	Ultimate tensile strength	3094 (psi)
Buffering capacity	<1 mL	Elongation	416 (%)
Non-volatile residue	<1 mg	Yield strength	1972 (psi)
Residue on ignition	<1 mg	Seam strength	18 pounds
Appearance	Pass	Temperature range	-80° to 60°C
Acidity and alkalinity	Pass	Sterilization	SAL 10 <sup>-6</sup>
Absorbance	0.04 units		
Oxidizable substance	<0.1 mL		
Transparency	Pass		

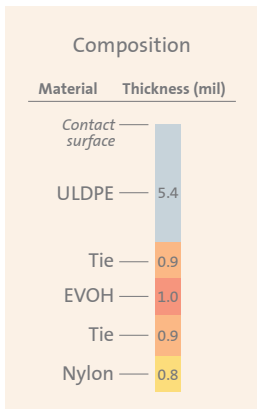

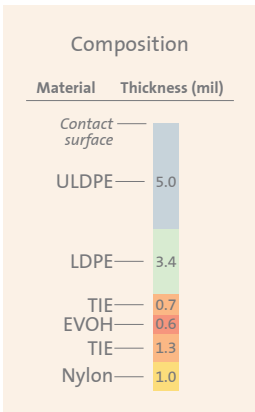
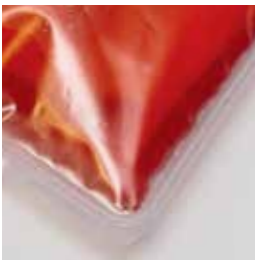
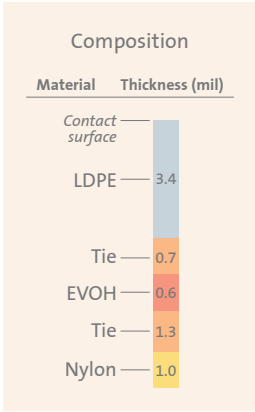

### Polyethylene (PE) Film

7 mil co-extrusion film.

#### Technical Information

Biocompatibility Tests	Result	Test Protocol
USP intracutaneous reactivity test	Pass	USP <88>
USP acute systemic injection test	Pass	USP <88>
USP intramuscular implantation test	Pass	USP <88>
USP MEM elution method	Non-cytotoxic	USP <87>
Physiochemical test for plastics	Pass	USP <661>

Physical Properties	Result	Test
H <sub>2</sub> O transmission (g/100 in <sup>2</sup> /24 hrs)	0.044	ASTM F-1249
CO <sub>2</sub> transmission (cm <sup>3</sup> /100 in <sup>2</sup> /24 hrs)	0.145	ASTM F-2476
O <sub>2</sub> transmission (cm <sup>3</sup> /100 in <sup>2</sup> /24 hrs)	0.278	ASTM F-3985

	Average Force	Average MOE	Average Elongation	Test Protocol
Tensile	30.79 lbs	51670 psi	611%	ASTM D 882-02
	Minimum Force	Average Force	Maximum Force	
Tear resistance	4.86 lbs	5.20 lbs	5.45 lbs	ASTM D1004-07
Puncture resistance	13.89 lbs	15.29 lbs	17.12 lbs	FTMS 101C

### Ultra-Low Density Polyethylene (ULDPE) film

Fluid contact layer is 5.0 mil, ultra-low density polyethylene. Outer film is 5-layer, 7 mil co-extrusion film.

#### Technical Information

Biocompatibility Tests	Result	Test Protocol
USP intracutaneous reactivity test	Pass	USP <88>
USP acute systemic injection test	Pass	USP <88>
USP intramuscular implantation test	Pass	USP <88>
USP MEM elution method	Non-cytotoxic	USP <87>
Physiochemical test for plastics	Pass	USP <661>

Physical Properties	Result	Test
H <sub>2</sub> O transmission (g/100 in <sup>2</sup> /24 hrs)	0.017	ASTM F-1249
CO <sub>2</sub> transmission (cm <sup>3</sup> /100 in <sup>2</sup> /24 hrs)	0.129	ASTM F-2476
O <sub>2</sub> transmission (cm <sup>3</sup> /100 in <sup>2</sup> /24 hrs)	0.043	ASTM F-1927

	Average Force	Average MOE	Average Elongation	Test Protocol
Tensile	32.73 lbs	25110 psi	1080%	ASTM D 882-02
	Minimum Force	Average Force	Maximum Force	
Tear resistance	6.77 lbs	7.21 lbs	7.74 lbs	ASTM D1004-07
Puncture resistance	16.42 lbs	18.61 lbs	19.51 lbs	FTMS 101C

**Polyolefin Film**

Single-web, 12 mil polyolefin mono-layer designed for extremely low temperatures.

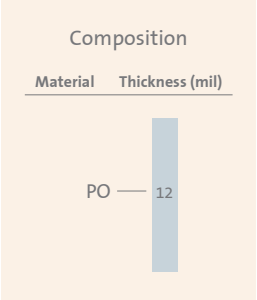

*Technical Information*

Biocompatibility Tests	Test Protocol	Result
USP Class VI	USP <88>	Pass
Cytotoxicity	ISO 10993-1	Pass
Bacterial endotoxin	USP <85>	Pass
Heavy metals	ISO 3826-1	<2ppm
Buffering capacity	USP <661>	1.22 ml
Non-volatile residue	USP <661>	8.6 mg
Residue on ignition (polyolefins)	ISO 3826-1	<1 mg
Acidity and alkalinity	ISO 3826-1	Pass
Oxidizable constituents	ISO 3826-1	<1.5 mL
Absorbance	ISO 3826-1	<0.2 abs unit
Reducing substances	EP 3.1.14	0.34 mL
Local effects after implantation	ISO 10993-6	Pass
Irritation and delayed-type sensitivity	ISO 10993-10	Pass
Systemic toxicity	ISO 10993-11	Pass

Physical Properties	Protocol	Result
Tensile strength	ASTM D-638	3400-3700 psi
Elongation at break	ASTM D-638	670-700%
Elastic modulus	ASTM D-638	540-480 psi
O <sub>2</sub> Transmission	ASTM D-3985	153 (cm <sup>3</sup> /100 in <sup>2</sup> /24 hrs) at (25°C; 0% RH)
CO <sub>2</sub> Transmission	MOCON test method	1183 (cm <sup>3</sup> /100 in <sup>2</sup> /24 hrs) at (25°C; 0% RH)
Water vapor transmission	ASTM D-1249	0.94 (g/100 in <sup>2</sup> /24 hrs) at (25°C; 0% RH)
Haze	ASTM D-1003	69%
Transmittance	ASTM D-1003	83%
Durometer hardness, Shore A	ASTMD-2240	74
Specific gravity	ASTM D-792	0.91 g/cm <sup>3</sup>
Tear resistance, (lb/ft)	ASTM D -1004	225-239
Low temperature, remains flexible	--	-196°C



# 9 Formulations

AMEM (Alpha Modification of Eagle's Medium).....	50
Antibiotic-Antimycotic Solution.....	50
Buffered Saline Solutions.....	51
CMRL 1066.....	51
DMEM (Dulbecco's Modification of Eagle's Medium).....	52-53
DMEM with glutagro™ Supplement.....	52
DMEM/Ham's F-12 50/50 Mix with glutagro™ Supplement.....	54
F-12K Nutrient Mixture.....	55
glutagro™ Supplement and L-Glutamine.....	55
Grace's Insect Basal Medium/Hink's TNM-FH Medium.....	56
Ham's F-10 Medium.....	57
Ham's F-12 Medium.....	58
HAT (Hypoxanthine, Aminopterin, Thymidine)/HT (Hypoxanthine, Thymidine).....	58
HEPES.....	58
HBSS (Hanks Balanced Salt Solutions).....	59
Improved MEM.....	59
Iscove's Modification of DMEM.....	60
ITS (Insulin, Transferrin, and Selenium).....	60
LSM (Lymphocyte Separation Medium).....	60
Leibovitz's L-15.....	61
McCoy's 5A.....	61
MCDB 131.....	62
M199 (Medium 199).....	63
MEM (Minimum Essential Medium) Amino Acids Solution.....	64
MEM Vitamin Solution.....	64
NEAA (MEM Non-essential Amino Acids Solution).....	64
Microbiological Media.....	65
Molecular Biology Buffers.....	65
MEM.....	66-67
Penicillin Streptomycin Solutions.....	67
Trace Elements.....	67
Trypsin/EDTA Solutions.....	68
TSB (Tryptic Soy Broth).....	68
Trypan Blue.....	68
RPMI 1640.....	69-70

**AMEM (Alpha Modification of Eagle's Medium)**

Cat. No.	10-022	15-012	50-012
Description	Liquid, 1x	Liquid, 1x	Powder
Units	mg/L	mg/L	mg/L

Components			
<i>Inorganic Salts</i>			
CaCl <sub>2</sub> (anhydrous)	200.00	200.00	200.00
KCl	400.00	400.00	400.00
MgSO <sub>4</sub> (anhydrous)	97.70	97.70	97.70
NaCl	6800.00	6800.00	6800.00
NaH <sub>2</sub> PO <sub>4</sub> • H <sub>2</sub> O	140.00	140.00	140.00
NaHCO <sub>3</sub>	2200.00	2200.00	--
<i>Amino Acids</i>			
L-Alanine	25.00	25.00	25.00
L-Arginine • HCl	126.40	126.40	126.40
L-Asparagine • H <sub>2</sub> O	50.00	50.00	50.00
L-Aspartic acid	30.00	30.00	30.00
L-Cysteine • HCl • H <sub>2</sub> O	100.00	100.00	100.00
L-Cystine • 2HCl	31.20	31.20	31.20
L-Glutamic acid	75.00	75.00	75.00
L-Glutamine	292.00	--	--
Glycine	50.00	50.00	50.00
L-Histidine • HCl • H <sub>2</sub> O	41.90	41.90	41.90
L-Isoleucine	52.50	52.50	52.50
L-Leucine	52.50	52.50	52.50
L-Lysine • HCl	72.50	72.50	72.50
L-Methionine	15.00	15.00	15.00
L-Phenylalanine	32.50	32.50	32.50
L-Proline	40.00	40.00	40.00
L-Serine	25.00	25.00	25.00
L-Threonine	47.60	47.60	47.60
L-Tryptophan	10.00	10.00	10.00
L-Tyrosine • 2Na • 2H <sub>2</sub> O	51.90	51.90	51.90
L-Valine	46.80	46.80	46.80
<i>Vitamins</i>			
Ascorbic acid	50.00	50.00	50.00
Biotin	0.10	0.10	0.10
D-Calcium pantothenate	1.00	1.00	1.00
Choline chloride	1.00	1.00	1.00
Folic acid	1.00	1.00	1.00
<i>i</i> -Inositol	2.00	2.00	2.00
Nicotinamide	1.00	1.00	1.00
Pyridoxine • HCl	1.00	1.00	1.00
Riboflavin	0.10	0.10	0.10
Thiamine • HCl	1.00	1.00	1.00
Vitamin B12	1.36	1.36	1.36

Cat. No.	10-022	15-012	50-012
Components			
<i>Other</i>			
D-Glucose	1000.00	1000.00	1000.00
Lipoic acid	0.20	0.20	0.20
Phenol red • Na	10.00	10.00	--
Sodium pyruvate	110.00	110.00	110.00
<i>Nucleosides</i>			
Thymidine	10.00	--	--
Adenosine	10.00	--	--
Cytidine	10.00	--	--
Guanosine	10.00	--	--
Uridine (anhydrous)	10.00	--	--
2'-Deoxyadenosine • H <sub>2</sub> O	10.00	--	--
2'-Deoxycytidine • HCl	11.00	--	--
2'-Deoxyguanosine • H <sub>2</sub> O	10.00	--	--

Add			
NaHCO <sub>3</sub> Powder (g/L)	--	--	2.20
7.5% Solution (mL/L)	--	--	29.33
L-Glutamine Powder (mg/L)	--	292.00	--
200 mM Solution (mL/L)	--	10.00	--

**Antibiotic-Antimycotic Solution**

Cat. No.	30-004
Description	Liquid, 100x
Units	mg/mL or g/L

Components	
K Penicillin G	10,000,000 U/L
Dihydro-Streptomycin • SO <sub>4</sub>	10.0 (adjusted for potency)
Amphotericin B (water soluble)	0.025 (adjusted for potency)
NaCl	8.5

## Buffered Saline Solutions

Cat. No.	20-030	20-031	21-030	21-031	55-031	21-040	46-013	46-012
Description	Liquid, 10x	Liquid, 10x	Liquid, 1x	Liquid, 1x	Powder	Liquid, 1x	Liquid, 10x	Liquid, 10x
Units	g/L	g/L	g/L	g/L	g/L	g/L	g/L	g/L

Components								
Inorganic Salts								
CaCl <sub>2</sub> (anhydrous)	1.00	--	0.10	--	--	--	--	--
KCl	2.00	2.00	0.20	0.20	0.20	--	2.0	--
KH <sub>2</sub> PO <sub>4</sub>	2.00	2.00	0.20	0.20	0.20	0.144	2.40	--
MgCl <sub>2</sub> • 6H <sub>2</sub> O	1.00	--	0.10	--	--	--	--	--
NaCl	80.00	80.00	8.00	8.00	8.00	9.00	80.00	80.00
Na <sub>2</sub> HPO <sub>4</sub> (anhydrous)	11.50	11.50	--	1.15	1.15	0.795	14.40	--
Na <sub>2</sub> HPO <sub>4</sub> • 7H <sub>2</sub> O	--	--	2.1716	--	--	--	--	--
Organic Buffers								
Tris Ultrapure	--	--	--	--	--	--	--	24.2

## CMRL 1066

Cat. No.	15-110
Description	Liquid, 1x
Units	mg/L

Components	
Inorganic Salts	
CaCl <sub>2</sub> (anhydrous)	200
KCl	400
MgSO <sub>4</sub> (anhydrous)	97.70
NaCl	6800
NaH <sub>2</sub> PO <sub>4</sub> • H <sub>2</sub> O	140
NaHCO <sub>3</sub>	2200
Amino Acids	
L-Alanine	25
L-Arginine • HCl	70
L-Aspartic Acid	30
L-Cysteine • HCl • H <sub>2</sub> O	260
L-Cystine • 2HCl	26
L-Glutamic Acid	75
Glycine	50
L-Histidine • HCl • H <sub>2</sub> O	20
Hydroxy-L-Proline	10
L-Isoleucine	20
L-Leucine	60
L-Lysine • HCl	70
L-Methionine	15
L-Phenylalanine	25
L-Proline	40
L-Serine	25
L-Threonine	30
L-Tryptophan	10
L-Tyrosine • 2Na • 2H <sub>2</sub> O	58
L-Valine	25

Cat. No.	15-110
Vitamins	
Biotin	0.01
Folic Acid	0.01
Riboflavin	0.01
Ascorbic Acid	50.00
D-Ca-Pantothenate	0.01
Choline Chloride	0.50
<i>i</i> -Inositol	0.05
Nicotinic Acid	0.025
Nicotinamide	0.025
PABA	0.05
Pyridoxine • HCl	0.05
Thiamine • HCl	0.01
Thiamine pyrophosphate, Na	1.00
Other	
Thymidine	10.00
2'-Deoxyadenosine • H <sub>2</sub> O	10.00
2'-Deoxycytidine • HCl	10.00
2'-Deoxyguanosine • H <sub>2</sub> O	10.00
5-Methyl-2'-Deoxycytidine	0.10
Uridine-5'-triphosphate • 3Na • hydrate	1.00
Cholesterol	0.20
Polysorbate 80	5.00
Coenzyme A Li <sub>3</sub> Salt • 2H <sub>2</sub> O	2.50
b-NAD • hydrate	7.00
b-NADP • Na • 4H <sub>2</sub> O	1.00
FAD Disodium Salt	1.00
Dextrose	1000
Glutathione (reduced)	10.00
Sodium acetate	50.00
Sodium glucuronate • H <sub>2</sub> O	4.20
Add	
L-Glutamine Powder (mg/L)	100.00
200 mM Solution (mL/L)	3.42

FORMULATIONS

**DMEM (Dulbecco's Modification of Eagle's Medium)**

Cat. No.	10-013	10-014	10-017	10-101	10-102	15-013	15-017	15-018	17-204
Description	Liquid, 1x	Liquid, 1x	Liquid, 1x	Liquid, 1x	Liquid, 1x	Liquid, 1x	Liquid, 1x	Liquid, 1x	Liquid, 1x
Units	mg/L	mg/L	mg/L	mg/L	mg/L	mg/L	mg/L	mg/L	mg/L

Components									
<i>Inorganic Salts</i>									
CaCl <sub>2</sub> (anhydrous)	200	200	200	200	200	200	200	200	200
Fe(NO <sub>3</sub> ) <sub>3</sub> • 9H <sub>2</sub> O	0.1	0.1	0.1	0.1	0.1	0.1	0.1	0.1	0.1
KCl	400	400	400	400	400	400	400	400	400
MgSO <sub>4</sub> (anhydrous)	97.7	97.7	97.7	97.7	97.7	97.7	97.7	97.7	97.7
NaCl	6400	6400	6400	6400	6400	6400	6400	6400	6400
NaH <sub>2</sub> PO <sub>4</sub> • H <sub>2</sub> O	125	125	125	125	125	125	125	125	125
NaHCO <sub>3</sub>	3700	3700	3700	3700	3700	3700	3700	3700	3700
<i>Amino Acids</i>									
L-Arginine • HCl	84	84	84	84	84	84	84	84.00	84.00
L-Cystine • 2HCl	62.57	62.57	62.57	62.57	62.57	62.57	62.57	62.57	--
L-Alanyl-L-glutamine	--	--	--	869	869	--	--	--	--
L-Glutamine	584	584	584	--	--	--	--	--	--
Glycine	30	30	30	30	30	30	30	30.00	30.00
L-Histidine • HCl • H <sub>2</sub> O	42	42	42	42	42	42	42	42.00	42.00
L-Isoleucine	104.8	104.8	104.8	104.8	104.8	104.8	104.8	104.80	104.80
L-Leucine	104.8	104.8	104.8	104.8	104.8	104.8	104.8	104.80	104.80
L-Lysine • HCl	146.2	146.2	146.2	146.2	146.2	146.2	146.2	146.20	146.20
L-Methionine	30	30	30	30	30	30	30	30.00	--
L-Phenylalanine	66	66	66	66	66	66	66	66.00	66.00
L-Serine	42	42	42	42	42	42	42	42.00	42.00
L-Threonine	95.2	95.2	95.2	95.2	95.2	95.2	95.2	95.20	95.20
L-Tryptophan	16	16	16	16	16	16	16	16.00	16.00
L-Tyrosine • 2Na • 2H <sub>2</sub> O	103.79	103.79	103.79	103.79	103.79	103.79	103.79	103.79	103.79
L-Valine	94	94	94	94	94	94	94	94.00	94.00
<i>Vitamins</i>									
D-Calcium pantothenate	4.00	4.00	4.00	4.00	4.00	4.00	4.00	4.00	4.00
Choline chloride	4.00	4.00	4.00	4.00	4.00	4.00	4.00	4.00	4.00
Folic acid	4.00	4.00	4.00	4.00	4.00	4.00	4.00	4.00	4.00
<i>i</i> -Inositol	7.20	7.20	7.20	7.20	7.20	7.20	7.20	7.20	7.20
Nicotinamide	4.00	4.00	4.00	4.00	4.00	4.00	4.00	4.00	4.00
Pyridoxine • HCl	4.00	4.00	4.00	4.00	4.00	4.00	4.00	4.00	4.00
Riboflavin	0.40	0.40	0.40	0.40	0.40	0.40	0.40	0.40	0.40
Thiamine • HCl	4.00	4.00	4.00	4.00	4.00	4.00	4.00	4.00	4.00
<i>Other</i>									
D-Glucose	4500.00	1000.00	4500.00	4500.00	4500.00	4500.00	4500.00	4500.00	4500.00
Phenol red • Na	15.00	15.00	15.00	15.00	15.00	15.00	15.00	15.00	15.00
Sodium pyruvate	110.00	110.00	--	110.00	--	110.00	--	110.00	110.00
HEPES	--	--	--	--	--	--	--	5958.00	--
<i>Add</i>									
L-Glutamine Powder (mg/L)	--	--	--	--	--	584.00	584.00	584.00	584.00
200 mM Solution (mL/L)	--	--	--	--	--	20.00	20.00	20.00	20.00

## DMEM (Dulbecco's Modification of Eagle's Medium)

Cat. No.	17-205	17-206	17-207	50-003	50-013	90-013	90-113
Description	Liquid, 1x	Liquid, 1x	Liquid, 1x	Powder	Powder	Powder	Powder
Units	mg/L	mg/L	mg/L	mg/L	mg/L	mg/L	mg/L

Components							
<i>Inorganic Salts</i>							
CaCl <sub>2</sub> (anhydrous)	200.00	200.00	200.00	200.00	200.00	200.00	200.00
Fe(NO <sub>3</sub> ) <sub>3</sub> • 9H <sub>2</sub> O	0.10	0.10	0.10	0.10	0.10	0.10	0.10
KCl	400.00	400.00	400.00	400.00	400.00	400.00	400.00
MgSO <sub>4</sub> (anhydrous)	97.70	97.70	97.70	97.70	97.70	97.70	97.70
NaCl	6400.00	6400.00	6400.00	6400.00	6400.00	6400.00	6400.00
NaH <sub>2</sub> PO <sub>4</sub> • H <sub>2</sub> O	125.00	--	125.00	125.00	125.00	125.00	125.00
NaHCO <sub>3</sub>	3700.00	3700.00	3700.00	--	--	--	--
<i>Amino Acids</i>							
L-Arginine • HCl	84.00	84.00	84.00	84.00	84.00	84.00	84.00
L-Cystine • 2HCl	62.57	62.57	62.57	62.57	62.57	62.57	62.57
L-Glutamine	--	--	--	584.00	584.00	--	--
Glycine	30.00	30.00	30.00	30.00	30.00	30.00	30.00
L-Histidine • HCl • H <sub>2</sub> O	42.00	42.00	42.00	42.00	42.00	42.00	42.00
L-Isoleucine	104.80	104.80	104.80	104.80	104.80	104.80	104.80
L-Leucine	104.80	104.80	104.80	104.80	104.80	104.80	104.80
L-Lysine • HCl	146.20	146.20	146.20	146.20	146.20	146.20	146.20
L-Methionine	30.00	30.00	30.00	30.00	30.00	30.00	30.00
L-Phenylalanine	66.00	66.00	66.00	66.00	66.00	66.00	66.00
L-Serine	42.00	42.00	42.00	42.00	42.00	42.00	42.00
L-Threonine	95.20	95.20	95.20	95.20	95.20	95.20	95.20
L-Tryptophan	16.00	16.00	16.00	16.00	16.00	16.00	16.00
L-Tyrosine • 2Na • 2H <sub>2</sub> O	103.79	103.79	103.79	103.79	103.79	103.79	103.79
L-Valine	94.00	94.00	94.00	94.00	94.00	94.00	94.00
<i>Vitamins</i>							
D-Calcium pantothenate	4.00	4.00	4.00	4.00	4.00	4.00	4.00
Choline chloride	4.00	4.00	4.00	4.00	4.00	4.00	4.00
Folic acid	4.00	4.00	4.00	4.00	4.00	4.00	4.00
<i>i</i> -Inositol	7.20	7.20	7.20	7.20	7.20	7.20	7.20
Nicotinamide	4.00	4.00	4.00	4.00	4.00	4.00	4.00
Pyridoxine • HCl	4.00	4.00	4.00	4.00	4.00	4.00	4.00
Riboflavin	0.40	0.40	0.40	0.40	0.40	0.40	0.40
Thiamine • HCl	4.00	4.00	4.00	4.00	4.00	4.00	4.00
<i>Other</i>							
D-Glucose	4500.00	4500.00	--	4500.00	4500.00	4500.00	--
Phenol red • Na	--	15.00	15.00	15.00	15.00	--	--
Sodium pyruvate	110.00	110.00	--	110.00	--	--	--
HEPES	--	--	--	--	--	--	--
<i>Add</i>							
NaHCO <sub>3</sub>							
Powder (g/L)	--	--	--	3.70	3.70	3.70	3.70
7.5% Solution (mL/L)	--	--	--	49.40	49.40	49.40	49.40
L-Glutamine							
Powder (mg/L)	584.00	584.00	584.00	--	--	584.00	584.00
200 mM Solution (mL/L)	20.00	20.00	20.00	--	--	20.00	20.00

FORMULATIONS

DMEM/Ham's F-12 50/50 Mix

Cat. No.	10-090	10-092	10-103	16-405	90-090	90-091
Description	Liquid, 1x	Liquid, 1x	Liquid, 1x	Liquid, 1x	Powder	Powder
Units	mg/L	mg/L	mg/L	mg/L	mg/L	mg/L

Components						
Inorganic Salts						
CaCl <sub>2</sub> (anhydrous)	116.65	116.65	116.65	116.65	116.65	116.65
FeSO <sub>4</sub> • 7H <sub>2</sub> O	0.417	0.417	0.417	0.417	0.417	0.417
Fe(NO <sub>3</sub> ) <sub>3</sub> • 9H <sub>2</sub> O	0.05	0.05	0.05	0.05	0.05	0.05
KCl	311.8	311.8	311.8	311.8	311.8	311.8
CuSO <sub>4</sub> (anhydrous)	0.0008	0.0008	0.0008	0.0008	0.0008	0.0008
MgSO <sub>4</sub> (anhydrous)	84.95	84.95	84.95	84.95	84.95	84.95
NaCl	7000	7000	7000	7000	7000	7000
NaH <sub>2</sub> PO <sub>4</sub> • H <sub>2</sub> O	62.5	62.5	62.5	62.5	62.5	62.5
Na <sub>2</sub> HPO <sub>4</sub> (anhydrous)	71	71	71	71	71	71
NaHCO <sub>3</sub>	2438	2438	2438	2438	--	--
ZnSO <sub>4</sub> • 7H <sub>2</sub> O	0.4315	0.4315	0.4315	0.4315	0.4315	0.4315
Amino Acids						
L-Alanine	4.45	4.45	4.45	4.45	4.45	4.45
L-Arginine • HCl	147.5	147.5	147.5	147.5	147.5	147.5
L-Asparagine • H <sub>2</sub> O	7.5	7.5	7.5	7.5	7.5	7.5
L-Aspartic acid	6.65	6.65	6.65	6.65	6.65	6.65
L-Cysteine • HCl • H <sub>2</sub> O	17.56	17.56	17.56	17.56	17.56	17.56
L-Cystine • 2HCl	31.285	31.285	31.285	31.285	31.285	31.285
L-Glutamic acid	7.35	7.35	7.35	7.35	7.35	7.35
L-Alanyl-L-Glutamine	--	--	543	--	--	--
L-Glutamine	365.1	365.1	--	365.1	--	--
Glycine	18.75	18.75	18.75	18.75	18.75	18.75
L-Histidine • HCl • H <sub>2</sub> O	31.48	31.48	31.48	31.48	31.48	31.48
L-Isoleucine	54.37	54.37	54.37	54.37	54.37	54.37
L-Leucine	58.95	58.95	58.95	58.95	58.95	58.95
L-Lysine • HCl	91.35	91.35	91.35	91.35	91.35	91.35
L-Methionine	17.24	17.24	17.24	17.24	17.24	17.24
L-Phenylalanine	35.48	35.48	35.48	35.48	35.48	35.48
L-Proline	17.25	17.25	17.25	17.25	17.25	17.25
L-Serine	26.25	26.25	26.25	26.25	26.25	26.25
L-Threonine	53.55	53.55	53.55	53.55	53.55	53.55
L-Tryptophan	9.02	9.02	9.02	9.02	9.02	9.02
L-Tyrosine • 2Na • 2H <sub>2</sub> O	55.815	55.815	55.815	55.815	55.815	55.815
L-Valine	52.85	52.85	52.85	52.85	52.85	52.85
Vitamins						
Biotin	0.00365	0.00365	0.00365	0.00365	0.00365	0.00365
D-Ca-Pantothenate	2.24	2.24	2.24	2.24	2.24	2.24
Choline Chloride	8.98	8.98	8.98	8.98	8.98	8.98
Folic Acid	2.65	2.65	2.65	2.65	2.65	2.65
<i>i</i> -Inositol	12.61	12.61	12.61	12.61	12.61	12.61
Nicotinamide	2.0185	2.0185	2.0185	2.0185	2.0185	2.0185
Pyridoxine • HCl	2.031	2.031	2.031	2.031	2.031	2.031
Riboflavin	0.219	0.219	0.219	0.219	0.219	0.219
Thiamine • HCl	2.17	2.17	2.17	2.17	2.17	2.17
Vitamin B12	0.68	0.68	0.68	0.68	0.68	0.68

Cat. No.	10-090	10-092	10-103	16-405	90-090	90-091
Other						
Dextrose	3151	3151	3151	3151	3151	3151
Hypoxanthine, Sodium	2.385	2.385	2.385	2.385	2.385	2.385
DL-Thioctic (lipoic) acid	0.105	0.105	0.105	0.105	0.105	0.105
Methyl Lineoleate	0.044	0.044	0.044	0.044	0.044	0.044
Phenol Red, Sodium	8.1	8.1	8.1	--	--	8.1
Putrescine*2HCl	0.08	0.08	0.08	0.08	0.08	0.08
Sodium Pyruvate	110	110	110	110	110	110
Thymidine	0.365	0.365	0.365	0.365	0.365	0.365
HEPES	--	3574.8	--	--	--	--
Add						
NaHCO <sub>3</sub>						
Powder (g/L)	--	--	--	--	2.438	2.438
7.5% Solution (mL/L)	--	--	--	--	32.50	32.50
L-Glutamine						
Powder (mg/L)	--	--	--	--	365.10	365.10
200 mM Solution (mL/L)	--	--	--	--	12.50	12.50

**F-12K Nutrient Mixture (Kaighn's Modification)**

<b>Cat. No.</b>	<b>10-025</b>
<b>Description</b>	<b>Liquid, 1x</b>
<b>Units</b>	<b>mg/L</b>

<b>Components</b>	
<i>Inorganic Salts</i>	
CaCl <sub>2</sub> (anhydrous)	102.00
CuSO <sub>4</sub> • 5H <sub>2</sub> O	0.002
FeSO <sub>4</sub> • 7H <sub>2</sub> O	0.800
KCl	285.00
KH <sub>2</sub> PO <sub>4</sub>	59.00
MgCl <sub>2</sub> (anhydrous)	49.70
MgSO <sub>4</sub> (anhydrous)	192.00
NaCl	7530.00
Na <sub>2</sub> HPO <sub>4</sub> (anhydrous)	115.50
NaHCO <sub>3</sub>	2500.00
ZnSO <sub>4</sub> • 7H <sub>2</sub> O	0.144
<i>Amino Acids</i>	
L-Alanine	18.00
L-Arginine • HCl	422.00
L-Asparagine • H <sub>2</sub> O	30.00
L-Aspartic acid	26.60
L-Cysteine • HCl • H <sub>2</sub> O	70.00
L-Glutamic acid	29.00
L-Glutamine	292.00
Glycine	15.00
L-Histidine • HCl • H <sub>2</sub> O	45.80
L-Isoleucine	7.88
L-Leucine	26.20
L-Lysine • HCl	73.00
L-Methionine	8.96
L-Phenylalanine	9.92
L-Proline	69.00
L-Serine	21.00
L-Threonine	23.00
L-Tryptophan	4.10
L-Tyrosine • 2Na • 2H <sub>2</sub> O	13.50
L-Valine	23.00

<b>Cat. No.</b>	<b>10-025</b>	
<b>Components</b>		
<i>Vitamins</i>		
Biotin	0.070	
D-Calcium pantothenate	0.50	
Choline chloride	14.00	
Folic acid	1.30	
<i>i</i> -Inositol	18.00	
Nicotinamide	0.037	
Pyridoxine • HCl	0.060	
Riboflavin	0.040	
Thiamine • HCl	0.30	
Vitamin B <sub>12</sub>	1.40	
<i>Other</i>		
D-Glucose	1260.00	
Hypoxanthine, Na	4.00	
Lipoic acid	0.21	
Phenol red • Na	3.00	
Putrescine • 2HCl	0.32	
Sodium pyruvate	220.00	
Thymidine	0.70	

**Glutago™ Supplement and L-Glutamine**

<b>Cat. No.</b>	<b>25-015</b>	<b>25-005</b>
<b>Description</b>	<b>Liquid, 100x</b>	<b>Liquid, 100x</b>
<b>Units</b>	<b>g/L</b>	<b>g/L</b>

<b>Components</b>		
L-alanyl-L-glutamine	43.44	--
L-Glutamine	--	29.20
NaCl	8.5	8.5

**Grace's Insect Basal Medium (Vaughn Modification) / Hink's TNM-FH Medium (Supplemented Grace's Medium)**

Cat. No.	13-200	13-100
Description	Liquid, 1x	Liquid, 1x
Units	mg/L	mg/L

Components		
<i>Inorganic Salts</i>		
CaCl <sub>2</sub> (anhydrous)	750.00	750.00
KCl	3720.00	2220.00
MgCl <sub>2</sub> (anhydrous)	1068.00	1068.00
MgSO <sub>4</sub> (anhydrous)	1358.00	1358.00
NaH <sub>2</sub> PO <sub>4</sub> • H <sub>2</sub> O	1008.00	1008.00
NaHCO <sub>3</sub>	350.00	350.00
<i>Amino Acids</i>		
β-Alanine	200.00	200.00
L-Alanine	225.00	225.00
L-Arginine • HCl	700.00	700.00
L-Asparagine • H <sub>2</sub> O	350.00	350.00
L-Aspartic acid	350.00	350.00
L-Cystine • 2HCl	25.00	25.00
L-Glutamic acid	600.00	600.00
L-Glutamine	600.00	600.00
Glycine	650.00	650.00
L-Histidine	2500.00	2500.00
L-Isoleucine	50.00	50.00
L-Leucine	75.00	75.00
L-Lysine • HCl	625.00	625.00
L-Methionine	50.00	50.00
L-Phenylalanine	150.00	150.00
L-Proline	350.00	350.00
DL-Serine	1100.00	1100.00
L-Threonine	175.00	175.00
L-Tryptophan	100.00	100.00
L-Tyrosine	50.00	50.00
L-Valine	100.00	100.00
<i>Vitamins</i>		
Biotin	0.01	0.01
D-Calcium pantothenate	0.02	0.02
Choline chloride	0.20	0.20
Folic acid	0.02	0.02
<i>i</i> -Inositol	0.02	0.02
Nicotinic acid	0.02	0.02
Para-Aminobenzoic acid	0.02	0.02
Pyridoxine • HCl	0.02	0.02
Riboflavin	0.02	0.02
Thiamine • HCl	0.02	0.02

Cat. No.	13-200	13-100
Components		
<i>Other</i>		
a-Ketoglutaric acid	370.00	370.00
D-Glucose	700.00	700.00
D-Fructose	400.00	400.00
Fumaric acid	55.00	55.00
L-Malic acid	670.00	670.00
Succinic acid	60.00	60.00
Sucrose	26680.00	26680.00
Lactalbumin hydrolysate	--	3333.00
UF Yeast Extract	--	3333.00

## Ham's F-10 Medium

Cat. No.	10-070
Description	Liquid, 1x
Units	mg/L

Components	
<i>Inorganic Salts</i>	
CaCl <sub>2</sub> (anhydrous)	33.30
CuSO <sub>4</sub> (anhydrous)	0.0016
FeSO <sub>4</sub> • 7H <sub>2</sub> O	0.834
KCl	285.00
KH <sub>2</sub> PO <sub>4</sub>	83.00
MgSO <sub>4</sub> (anhydrous)	74.60
NaCl	7400.00
Na <sub>2</sub> HPO <sub>4</sub> (anhydrous)	153.70
NaHCO <sub>3</sub>	1200.00
ZnSO <sub>4</sub> • 7H <sub>2</sub> O	0.0288
<i>Amino Acids</i>	
L-Alanine	9.00
L-Arginine • HCl	211.00
L-Asparagine • H <sub>2</sub> O	15.00
L-Aspartic acid	13.00
L-Cysteine • HCl • H <sub>2</sub> O	35.10
L-Glutamic acid	14.70
L-Glutamine	146.20
Glycine	7.50
L-Histidine • HCl • H <sub>2</sub> O	23.00
L-Isoleucine	2.60
L-Leucine	13.00
L-Lysine • HCl	29.00
L-Methionine	4.48
L-Phenylalanine	5.00
L-Proline	11.50
L-Serine	10.50
L-Threonine	3.57
L-Tryptophan	0.60
L-Tyrosine • 2Na • 2H <sub>2</sub> O	2.61
L-Valine	3.50
<i>Vitamins</i>	
Biotin	0.024
D-Calcium pantothenate	0.715
Choline chloride	0.698
Folic acid	1.32
<i>i</i> -Inositol	0.541
Nicotinamide	0.615
Pyridoxine • HCl	0.206
Riboflavin	0.376
Thiamine • HCl	1.00
Vitamin B <sub>12</sub>	1.36

Cat. No.	10-070
Components	
<i>Other</i>	
D-Glucose	1100.00
Hypoxanthine, Na	4.77
DL-Thioctic (lipoic) acid	0.20
Phenol red • Na	1.20
Sodium pyruvate	110.00
Thymidine	0.73

**Ham's F-12 Medium**

Cat. No.	10-080	50-040
Description	Liquid, 1x	Powder
Units	mg/L	mg/L

Components		
Inorganic Salts		
CaCl <sub>2</sub> (anhydrous)	33.30	33.30
CuSO <sub>4</sub> (anhydrous)	0.0016	0.0016
FeSO <sub>4</sub> • 7H <sub>2</sub> O	0.834	0.834
KCl	223.60	223.60
MgSO <sub>4</sub> (anhydrous)	72.20	72.20
NaCl	7600.00	7600.00
Na <sub>2</sub> HPO <sub>4</sub> (anhydrous)	142.00	142.00
NaHCO <sub>3</sub>	1176.00	--
ZnSO <sub>4</sub> • 7H <sub>2</sub> O	0.863	0.863
Amino Acids		
L-Alanine	8.9	8.9
L-Arginine • HCl	211.00	211.00
L-Asparagine • H <sub>2</sub> O	15.00	15.00
L-Aspartic acid	13.30	13.30
L-Cysteine • HCl • H <sub>2</sub> O	35.12	35.12
L-Glutamic acid	14.70	14.70
L-Glutamine	146.20	146.20
Glycine	7.50	7.50
L-Histidine • HCl • H <sub>2</sub> O	20.96	20.96
L-Isoleucine	3.94	3.94
L-Leucine	13.10	13.10
L-Lysine • HCl	36.50	36.50
L-Methionine	4.48	4.48
L-Phenylalanine	4.96	4.96
L-Proline	34.50	34.50
L-Serine	10.50	10.50
L-Threonine	11.90	11.90
L-Tryptophan	2.04	2.04
L-Tyrosine • 2Na • 2H <sub>2</sub> O	7.84	7.84
L-Valine	11.70	11.70
Vitamins		
Nicotinamide	0.037	0.037
Pyridoxine • HCl	0.062	0.062
Riboflavin	0.038	0.038
Thiamine • HCl	0.34	0.34
Vitamin B <sub>12</sub>	1.36	1.36

Cat. No.	10-080	50-040
Components		
<i>Other</i>		

D-Glucose	1802.00	1802.00
Hypoxanthine, Na	4.77	4.77
DL-Thioctic (lipoic) acid	0.21	0.21
Methyl lineoleate	0.088	0.088
Phenol red • Na	1.20	1.20
Putrescine • 2HCl	0.16	0.16
Sodium pyruvate	110.00	110.00
Thymidine	0.73	0.73

Add		
NaHCO <sub>3</sub>		
Powder (g/L)	--	1.176
7.5% Solution (mL/L)	--	15.70

**HAT (Hypoxanthine, Aminopterin, Thymidine) / HT (Hypoxanthine, Thymidine)**

Cat. No.	25-046	25-047
Description	HAT Liquid, 50x	HT Liquid, 50x
Units	mg/L	mg/L

Components		
Aminopterin	8.81	--
Hypoxanthine • Na	910.70	910.70
Thymidine	193.80	193.80

**HEPES**

Cat. No.	25-060
Description	Liquid, 1M
Units	g/L

Components	
HEPES	238.3

### HBSS (Hanks Balanced Salt Solutions)

Cat. No.	20-021	20-023	21-020	21-021	21-022	21-023	55-021	55-022
Description	Liquid, 10x	Liquid, 10x	Liquid, 1x	Liquid, 1x	Liquid, 1x	Liquid, 1x	Powder	Powder
Units	g/L	g/L	g/L	g/L	g/L	g/L	g/L	g/L

Components								
Inorganic Salts								
CaCl <sub>2</sub> (anhydrous)	--	1.4	0.14	--	--	0.14	--	--
KCl	4.00	4.00	0.40	0.40	0.40	0.40	0.40	0.40
KH <sub>2</sub> PO <sub>4</sub>	0.60	0.60	0.06	0.06	0.06	0.06	0.06	0.06
MgSO <sub>4</sub> (anhydrous)	--	0.977	0.0977	--	--	0.0977	--	--
NaCl	80.00	80.00	8.00	8.00	8.00	8.00	8.00	8.00
Na <sub>2</sub> HPO <sub>4</sub> (anhydrous)	0.477	0.477	0.0477	0.0477	0.0477	0.0477	0.0477	0.0477
NaHCO <sub>3</sub>	--	--	0.35	0.35	0.35	0.35	--	--
Other								
D-Glucose	10.00	10.00	1.00	1.00	1.00	1.00	1.00	1.00
Phenol red • Na	0.10	--	0.01	0.01	--	--	0.01	--

Add								
NaHCO <sub>3</sub> Powder (g/L)	0.35	0.35	--	--	--	--	0.35	0.35
7.5% Solution (mL/L)	4.67	4.67	--	--	--	--	4.67	4.67

### Improved MEM (Richter's Modification)

Cat. No.	10-024	10-026
Description	Liquid, 1x	Liquid, 1x
Units	mg/L	mg/L

Components		
Inorganic Salts		
CaCl <sub>2</sub> (anhydrous)	200.00	200.00
FeCl <sub>3</sub> • 6H <sub>2</sub> O	0.54	0.54
KCl	400.00	400.00
MgCl <sub>2</sub> • 6H <sub>2</sub> O	183.00	183.00
MgSO <sub>4</sub> • 7H <sub>2</sub> O	25.00	25.00
NaCl	6800.00	6800.00
NaH <sub>2</sub> PO <sub>4</sub> • H <sub>2</sub> O	150.00	150.00
NaHCO <sub>3</sub>	2200.00	2200.00
ZnSO <sub>4</sub> • 7H <sub>2</sub> O	0.14	0.14
Amino Acids		
L-Arginine • HCl	127.00	127.00
L-Asparagine • H <sub>2</sub> O	60.00	60.00
L-Cystine • 2HCl	31.28	31.28
L-Glutamine	292.00	292.00
L-Histidine • HCl • H <sub>2</sub> O	42.00	42.00
L-Isoleucine	52.00	52.00
L-Leucine	131.20	131.20
L-lysine • HCl	72.60	72.60
L-Methionine	15.00	15.00

Cat. No.	10-024	10-026
Components		
L-Phenylalanine	32.00	32.00
L-Serine	42.00	42.00
L-Threonine	48.00	48.00
L-Tryptophan	10.00	10.00
L-Tyrosine • 2Na • 2H <sub>2</sub> O	51.89	51.89
L-Valine	46.00	46.00
Vitamins		
Biotin	0.10	0.10
D-Calcium pantothenate	1.00	1.00
Choline chloride	56.00	56.00
Folic acid	2.20	2.20
<i>i</i> -Inositol	36.00	36.00
Linoleic acid	0.08	0.08
DL-Thioctic (lipoic) acid	0.20	0.20
Nicotinamide	1.00	1.00
Pyridoxine • HCl	1.00	1.00
Riboflavin	0.10	0.10
Thiamine • HCl	1.00	1.00
Vitamin B <sub>12</sub>	1.36	1.36
Other		
D-Glucose	2000.00	2000.00
Phenol red • Na	10.00	--
Putrescine • 2HCl	0.16	0.16
Sodium pyruvate	110.00	110.00

**Iscove's Modification of DMEM**

Cat. No.	10-016	15-016	50-016
Description	Liquid, 1x	Liquid, 1x	Powder
Units	mg/L	mg/L	mg/L

Components			
<i>Inorganic Salts</i>			
CaCl <sub>2</sub> (anhydrous)	165.00	165.00	165.00
KCl	330.00	330.00	330.00
KNO <sub>3</sub>	0.076	0.076	0.076
MgSO <sub>4</sub> (anhydrous)	97.70	97.70	97.70
Na <sub>2</sub> SeO <sub>3</sub>	0.0173	0.0173	0.0173
NaCl	4505.00	4505.00	4505.00
NaH <sub>2</sub> PO <sub>4</sub> • H <sub>2</sub> O	125.00	125.00	125.00
NaHCO <sub>3</sub>	3024.00	3024.00	--
<i>Amino Acids</i>			
L-Alanine	25.00	25.00	25.00
L-Arginine • HCl	84.00	84.00	84.00
L-Asparagine • H <sub>2</sub> O	28.40	28.40	28.40
L-Aspartic acid	30.00	30.00	30.00
L-Cystine • 2HCl	91.24	91.24	91.24
L-Glutamic acid	75.00	75.00	75.00
L-Glutamine	584.00	--	584.00
Glycine	30.00	30.00	30.00
L-Histidine • HCl • H <sub>2</sub> O	42.00	42.00	42.00
L-Isoleucine	105.00	105.00	105.00
L-Leucine	105.00	105.00	105.00
L-Lysine • HCl	146.00	146.00	146.00
L-Methionine	30.00	30.00	30.00
L-Phenylalanine	66.00	66.00	66.00
L-Proline	40.00	40.00	40.00
L-Serine	42.00	42.00	42.00
L-Threonine	95.00	95.00	95.00
L-Tryptophan	16.00	16.00	16.00
L-Tyrosine • 2Na • 2H <sub>2</sub> O	103.79	103.79	103.79
L-Valine	94.00	94.00	94.00
<i>Vitamins</i>			
Biotin	0.013	0.013	0.013
D-Calcium pantothenate	4.00	4.00	4.00
Choline chloride	4.00	4.00	4.00
Folic acid	4.00	4.00	4.00
<i>i</i> -Inositol	7.20	7.20	7.20
Nicotinamide	4.00	4.00	4.00
Pyridoxine • HCl	4.00	4.00	4.00
Riboflavin	0.40	0.40	0.40
Thiamine • HCl	4.00	4.00	4.00
Vitamin B <sub>12</sub>	0.013	0.013	0.013

Cat. No.	10-016	15-016	50-016
Components			
<i>Other</i>			
D-Glucose	4500.00	4500.00	4500.00
HEPES	5958.00	5958.00	5958.00
Phenol red • Na	15.00	15.00	15.00
Sodium pyruvate	110.00	110.00	110.00

Add			
L-Glutamine			
Powder (mg/L)	--	584.00	--
200 mM Solution (mL/L)	--	20.00	--
NaHCO <sub>3</sub>			40.27
Powder (g/L): 3.02			
7.5% Solution (mL/L)			

**ITS (Insulin, Transferrin, and Selenium Solution)**

Cat. No.	25-800-CR
Description	Liquid Solution, 100x
Units	mg/L

Components	
Selenious acid	0.67
Insulin, human recombinant	1000
Transferrin, human recombinant	550

**LSM (Lymphocyte Separation Medium)**

Cat. No.	25-072
Description	Liquid
Units	g/L

Components	
Diatrizoic acid	96.219
Polysucrose 400	61.363

## Leibovitz's L-15

Cat. No.	10-045	50-045
Description	Liquid, 1x	Powder
Units	mg/L	mg/L

Components		
<i>Inorganic Salts</i>		
CaCl <sub>2</sub> (anhydrous)	140.06	140.06
KCl	400.00	400.00
KH <sub>2</sub> PO <sub>4</sub>	60.00	60.00
MgCl <sub>2</sub> • 6H <sub>2</sub> O	200.00	200.00
MgSO <sub>4</sub> (anhydrous)	97.67	97.67
NaCl	8000.00	8000.00
Na <sub>2</sub> HPO <sub>4</sub> (anhydrous)	190.00	190.00
<i>Amino Acids</i>		
L-Alanine	225.00	225.00
L-Arginine	500.00	500.00
L-Asparagine • H <sub>2</sub> O	250.00	250.00
L-Cysteine	120.00	120.00
L-Glutamine	300.00	300.00
Glycine	200.00	200.00
L-Histidine	250.00	250.00
L-Isoleucine	125.00	125.00
L-Leucine	125.00	125.00
L-lysine • HCl	93.70	93.70
L-Methionine	75.00	75.00
L-Phenylalanine	125.00	125.00
L-Serine	200.00	200.00
L-Threonine	300.00	300.00
L-Tryptophan	20.00	20.00
L-Tyrosine • 2Na • 2H <sub>2</sub> O	430.00	430.00
L-Valine	100.00	100.00
<i>Vitamins</i>		
D-Calcium pantothenate	1.00	1.00
Choline chloride	1.00	1.00
Folic acid	1.00	1.00
<i>i</i> -Inositol	2.00	2.00
Nicotinamide	1.00	1.00
Pyridoxine • HCl	1.00	1.00
Riboflavin-5-PO <sub>4</sub> • Na	0.10	0.10
Thiamine • PO <sub>4</sub> • Cl • 2H <sub>2</sub> O	1.09	1.09
<i>Other</i>		
D-Galactose	900.00	900.00
Phenol red • Na	10.00	10.00
Sodium pyruvate	550.00	550.00

## McCoy's 5A Medium (Iwakata and Grace Modification)

Cat. No.	10-050	10-051
Description	Liquid, 1x	Liquid, 1x
Units	mg/L	mg/L

Components		
<i>Inorganic Salts</i>		
CaCl <sub>2</sub> (anhydrous)	100.00	100.00
KCl	400.00	400.00
MgSO <sub>4</sub> (anhydrous)	97.70	97.70
NaCl	6460.00	5960.00
NaH <sub>2</sub> PO <sub>4</sub> • H <sub>2</sub> O	580.00	580.00
NaHCO <sub>3</sub>	2200.00	2200.00
<i>Amino Acids</i>		
L-Alanine	13.36	13.36
L-Arginine • HCl	42.14	42.14
L-Asparagine • H <sub>2</sub> O	45.03	45.03
L-Aspartic acid	19.97	19.97
L-Cysteine • HCl • H <sub>2</sub> O	35.14	35.14
L-Glutamic acid	22.10	22.10
L-Glutamine	219.20	219.20
L-Glycine	7.50	7.50
L-Histidine • HCl • H <sub>2</sub> O	20.96	20.96
Hydroxy-L-proline	19.70	19.70
L-Isoleucine	39.36	39.36
L-Leucine	39.36	39.36
L-lysine • HCl	36.54	36.54
L-Methionine	14.92	14.92
L-Phenylalanine	16.52	16.52
L-Proline	17.30	17.30
L-Serine	26.30	26.30
L-Threonine	17.90	17.90
L-Tryptophan	3.10	3.10
<i>Vitamins</i>		
Ascorbic acid	0.50	0.50
Biotin	0.20	0.20
D-Calcium pantothenate	0.20	0.20
Choline chloride	5.00	5.00
Folic acid	10.00	10.00
<i>i</i> -Inositol	36.00	36.00
Nicotinamide	0.50	0.50
Nicotinic acid	0.50	0.50
Para-aminobenzoic acid	1.00	1.00
Pyridoxine • HCl	1.00	1.00
Riboflavin	0.20	0.20
Thiamine • HCl	0.20	0.20
Vitamin B <sub>12</sub>	2.00	2.00
<i>Other</i>		
Bacto-peptone	600.00	600.00
D-Glucose	3000.00	3000.00
Glutathione (reduced)	0.50	0.50
HEPES	--	5958.00
Phenol red • Na	10.00	10.00

**MCDB 131**

<b>Cat. No.</b>	<b>15-100</b>
<b>Description</b>	<b>Liquid, 1x</b>
<b>Units</b>	<b>mg/L</b>

<b>Components</b>	
<i>Inorganic Salts</i>	
CaCl <sub>2</sub> • 2H <sub>2</sub> O	235.20
CuSO <sub>4</sub> • 5H <sub>2</sub> O	0.0012
FeSO <sub>4</sub> • 7H <sub>2</sub> O	0.278
KCl	298.20
MgSO <sub>4</sub> (anhydrous)	1204.00
MnSO <sub>4</sub> • H <sub>2</sub> O	0.0002
NaCl	6428.40
Na <sub>2</sub> HPO <sub>4</sub> (anhydrous)	71.00
NaHCO <sub>3</sub>	1180.00
Na <sub>2</sub> SeO <sub>3</sub>	0.0052
Na <sub>2</sub> SiO <sub>3</sub> • 9H <sub>2</sub> O	2.842
(NH <sub>4</sub> ) <sub>6</sub> Mo <sub>7</sub> O <sub>24</sub> • 4H <sub>2</sub> O	0.0037
NH <sub>4</sub> VO <sub>3</sub>	0.0006
NiCl <sub>2</sub> • 6H <sub>2</sub> O	0.0001
ZnSO <sub>4</sub> • 7H <sub>2</sub> O	0.0003
<i>Amino Acids</i>	
L-Alanine	2.67
L-Arginine • HCl	63.21
L-Asparagine • H <sub>2</sub> O	15.01
L-Aspartic Acid	13.31
L-Cysteine • HCl • H <sub>2</sub> O	35.12
L-Glutamic Acid	4.413
L-Glycine	2.25
L-Histidine • HCl • H <sub>2</sub> O	41.92
L-Isoleucine	65.60
L-Leucine	131.20
L-Lysine • HCl	182.60

<b>Cat. No.</b>	<b>15-100</b>
<b>Components</b>	
L-Methionine	14.92
L-Phenylalanine	33.04
L-Proline	11.51
L-Serine	31.53
L-Threonine	11.91
L-Tryptophan	4.08

<i>Vitamins</i>	
Biotin	0.0073
D-Calcium pantothenate	11.915
Choline chloride	13.96
Calcium folinic acid	0.5115
<i>i</i> -Inositol	7.208
Nicotinamide	6.105
DL-Thioctic (lipoic) acid	0.0021
Pyridoxine • HCl	2.056
Riboflavin	0.0038
Thiamine • HCl	3.373
Vitamin B <sub>12</sub>	0.0136

<i>Other</i>	
D-Glucose	1000.00
Putrescine • 2HCl	0.0002
Phenol red • Na	12.421
Sodium pyruvate	110.00
Thymidine	0.0242
Adenine HCl	0.1716

<i>Add</i>	
L-Glutamine Powder(mg/L)	1461.5
200 mM Solution (mL/L)	50.0

**M199 (Medium 199)**

Cat. No.	10-060	50-050	50-051	90-050
Description	Liquid, 1x	Powder	Powder	Powder
Units	mg/L	mg/L	mg/L	mg/L

Components				
<i>Inorganic Salts</i>				
CaCl <sub>2</sub> (anhydrous)	200.00	200.00	140.00	200.00
Fe(NO <sub>3</sub> ) <sub>3</sub> • 9H <sub>2</sub> O	0.72	0.72	0.72	0.72
KCl	400.00	400.00	400.00	400.00
KH <sub>2</sub> PO <sub>4</sub>	--	--	60.00	--
MgSO <sub>4</sub> (anhydrous)	97.70	97.70	97.70	97.70
NaCl	6800.00	6800.00	8000.00	6800.00
NaH <sub>2</sub> PO <sub>4</sub> • H <sub>2</sub> O	140.00	140.00	--	140.00
Na <sub>2</sub> HPO <sub>4</sub> (anhydrous)	--	--	47.50	--
NaHCO <sub>3</sub>	2200.00	--	--	--
<i>Amino Acids</i>				
L-Alanine	25.00	25.00	25.00	25.00
L-Arginine • HCl	70.00	70.00	70.00	70.00
L-Aspartic acid	30.00	30.00	30.00	30.00
L-Cysteine • HCl • H <sub>2</sub> O	0.11	0.11	0.11	0.11
L-Cystine • 2HCl	26.00	26.00	26.00	26.00
L-Glutamic acid	75.00	75.00	75.00	75.00
L-Glutamine	100.00	100.00	100.00	--
Glycine	50.00	50.00	50.00	50.00
L-Histidine • HCl • H <sub>2</sub> O	21.88	21.88	21.88	21.88
Hydroxy-L-proline	10.00	10.00	10.00	10.00
L-Isoleucine	20.00	20.00	20.00	20.00
L-Leucine	60.00	60.00	60.00	60.00
L-lysine • HCl	70.00	70.00	70.00	70.00
L-Methionine	15.00	15.00	15.00	15.00
L-Phenylalanine	25.00	25.00	25.00	25.00
L-Proline	40.00	40.00	40.00	40.00
L-Serine	25.00	25.00	25.00	25.00
L-Threonine	30.00	30.00	30.00	30.00
L-Tryptophan	10.00	10.00	10.00	10.00
L-Tryosine • 2Na • 2H <sub>2</sub> O	57.87	57.87	57.87	57.87
L-Valine	25.00	25.00	25.00	25.00
<i>Vitamins</i>				
DL-alpha-Tocopherol • PO <sub>4</sub> • Na	0.01	0.01	0.01	0.01
Ascorbic acid	0.05	0.05	0.05	0.05
Biotin	0.01	0.01	0.01	0.01
Calciferol	0.10	0.10	0.10	0.10
D-Calcium pantothe-nate	0.01	0.01	0.01	0.01
Choline chloride	0.50	0.50	0.50	0.50
Folic acid	0.01	0.01	0.01	0.01

Cat. No.	10-060	50-050	50-051	90-050
Components				
<i>Vitamins</i>				
<i>i</i> -Inositol	0.05	0.05	0.05	0.05
Menadione • NaHSO <sub>3</sub> • 3H <sub>2</sub> O	0.019	0.019	0.019	0.019
Nicotinic acid	0.025	0.025	0.025	0.025
Nicotinamide	0.025	0.025	0.025	0.025
Para-Aminobenzoic acid	0.05	0.05	0.05	0.05
Pyridoxine • HCl	0.05	0.05	0.05	0.05
Riboflavin	0.01	0.01	0.01	0.01
Thiamine • HCl	0.01	0.01	0.01	0.01
Vitamin A acetate	0.14	0.14	0.14	0.14
<i>Other</i>				
Adenine sulfate	10.00	10.00	10.00	10.00
5-Adenylic acid • H <sub>2</sub> O	0.20	0.20	0.20	0.20
ATP • 2Na • 3H <sub>2</sub> O	1.00	1.00	1.00	1.00
Cholesterol	0.20	0.20	0.20	0.20
2-Deoxy-D-ribose	0.50	0.50	0.50	0.50
D-Glucose	1000.00	1000.00	1000.00	1000.00
Glutathione (reduced)	0.05	0.05	0.05	0.05
Guanine • HCl	0.30	0.30	0.30	0.30
Hypoxanthine • Na	0.354	0.354	0.354	0.354
Phenol red • Na	10.00	10.00	10.00	--
D-Ribose	0.50	0.50	0.50	0.50
Sodium acetate	50.00	50.00	50.00	50.00
Thymine	0.30	0.30	0.30	0.30
Polysorbate 80	20.00	20.00	20.00	20.00
Uracil	0.30	0.30	0.30	0.30
Xanthine • Na	0.34	0.34	0.34	0.34
<i>Add</i>				
NaHCO <sub>3</sub> Powder (g/L)	--	2.20	0.35	2.20
7.5% Solution (mL/L)	--	29.33	4.67	29.33
L-Glutamine Powder (mg/L)	--	--	--	100.00
200 mM Solution (mL/L)	--	--	--	3.40

**MEM Amino Acids Solution**

Cat. No.	25-030
Description	Liquid, 50x
Units	mg/L

Components	
L-Arginine • HCl	6320.00
L-Cystine • 2HCl	1560.00
L-Histidine • HCl • H <sub>2</sub> O	2095.00
L-Isoleucine	2625.00
L-Leucine	2625.00
L-Lysine • HCl	3625.00
L-Methionine	750.00
L-Phenylalanine	1625.00
L-Threonine	2380.00
L-Tryptophan	500.00
L-Tyrosine • HCl	2160.00
L-Valine	2340.00

**MEM Vitamin Solution**

Cat. No.	25-020
Description	100x Liquid
Units	mg/L

Components	
NaCl	8500.00
D-Calcium pantothenate	100.00
Choline chloride	100.00
Folic acid	100.00
<i>i</i> -Inositol	200.00
Nicotinamide	100.00
Pyridoxine • HCl	100.00
Riboflavin	10.00
Thiamine • HCl	100.00

**NEAA (MEM Nonessential Amino Acids Solution)**

Cat. No.	25-025
Description	Liquid, 100x
Units	mg/L

Components	
L-Alanine	890.00
L-Asparagine • H <sub>2</sub> O	1500.00
L-Aspartic acid	1330.00
L-Glutamic acid	1470.00
Glycine	750.00
L-Proline	1150.00
L-Serine	1050.00

## Microbiological Media

Cat. No.	46-003	46-050	46-055	46-060
Description	Liquid, S.O.C. Medium	Liquid LB Broth	Liquid Terrific Broth	Liquid Tryptic Soy Broth
Units	g/L	g/L	g/L	g/L

Components				
Casein peptone	20.00	10.00	12.00	--
Glycerol (mL)	--	--	4.00 (mL)	--
KH <sub>2</sub> PO <sub>4</sub>	--	--	2.31	--
K <sub>2</sub> HPO <sub>4</sub>	--	--	12.54	2.5
NaCl	0.5845	10.00	--	5.0
UF yeast powder	5.00	5.00	24.00	--
Dextrose	3.6032	--	--	2.5
KCl	0.186375	--	--	--
MgCl <sub>2</sub> (anhydrous)	0.9521	--	--	--
MgSO <sub>4</sub> (anhydrous)	1.2036	--	--	--
Non-animal origin peptone	--	--	--	20.0

## Molecular Biology Buffers

Cat. No.	46-009	46-010	46-011	46-020	46-030	46-031
Description	Liquid TE Buffer, 1x	Liquid TAE Buffer, 10x	Liquid TBE Buffer, 10x	Liquid SSC Buffer, 20x	1M Liquid Tris HCl pH 7.5, 1M	1M Liquid Tris HCl pH 8.0, 1M
Units	g/L	g/L	g/L	g/L	g/L	g/L

Components						
Boric acid	--	--	55	--	--	--
EDTA free acid (anhydrous)	--	2.922	2.92	--	--	--
EDTA • 2Na • 2H <sub>2</sub> O	0.37224	--	--	--	--	--
Glacial acetic acid	--	11.42	--	--	--	--
NaCl	--	--	--	175.35	--	--
Na citrate • 2H <sub>2</sub> O	--	--	--	88.2	--	--
Tris	0.46	48.4	108	--	21.78	66.67
Tris HCl	0.976	--	--	--	128.74	70.86

FORMULATIONS

Minimum Essential Medium (MEM)

Cat. No.	50-004	50-010	50-019	50-011	51-010	90-009	10-009	10-010	15-010	15-015	17-305
Description	Powder	Powder	Powder	Powder	Powder	Powder	Liquid, 1x	Liquid, 1x	Liquid, 1x	Liquid, 1x	Liquid, 1x
Units	mg/L	mg/L	mg/L	mg/L	mg/L	mg/L	mg/L	mg/L	mg/L	mg/L	mg/L
<b>Components</b>											
<i>Inorganic Salts</i>											
CaCl <sub>2</sub> (anhydrous)	200.00	200.00	140.00	200.00	200.00	200.00	200.00	200.00	200.00	--	200.00
Fe(NO <sub>3</sub> ) <sub>3</sub> • 9H <sub>2</sub> O	0.10	--	--	--	--	--	--	--	--	--	--
KCl	400.00	400.00	400.00	400.00	400.00	400.00	400.00	400.00	400.00	400.00	400.00
KH <sub>2</sub> PO <sub>4</sub>	--	--	60.00	--	--	--	--	--	--	--	--
MgSO <sub>4</sub> (anhydrous)	97.67	97.70	97.67	97.70	97.00	97.70	97.70	97.70	97.70	--	97.70
NaCl	6400	6800	8000	6800	6800	6800	6800.00	6800.00	6800.00	6800.00	6800.00
NaH <sub>2</sub> PO <sub>4</sub> • H <sub>2</sub> O	124.00	140.00	47.88	140.00	140.00	140.00	140.00	140.00	140.00	1217.00	140.00
Na succinate • 6H <sub>2</sub> O	--	--	--	--	100.00	--	--	--	--	--	--
NaHCO <sub>3</sub>	--	--	--	--	--	--	1500.00	2200.00	2200.00	2200.00	2200.00
<i>Amino Acids</i>											
L-Alanine	--	--	--	8.90	--	--	8.90	--	--	--	--
L-Arginine • HCl	42.00	126.40	126.00	126.40	126.40	126.40	126.40	126.40	126.40	126.40	126.40
L-Asparagine • H <sub>2</sub> O	--	--	--	15.00	--	--	15.00	--	--	--	--
L-Aspartic acid	--	--	--	13.30	--	--	13.30	--	--	--	--
L-Cystine • 2HCl	31.28	31.20	31.39	31.20	31.10	31.20	31.20	31.20	31.20	31.20	31.20
L-Glutamic acid	--	--	--	14.70	--	--	14.70	--	--	--	--
L-Glutamine	292.00	292.00	292.00	292.00	--	--	292.00	292.00	--	--	--
Glycine	--	--	--	7.50	--	--	7.50	--	--	--	--
L-Histidine • HCl • H <sub>2</sub> O	21.00	41.90	42.00	41.90	41.90	41.90	41.90	41.90	41.90	41.90	41.90
L-Isoleucine	52.40	52.50	52.00	52.50	52.50	52.50	52.50	52.50	52.50	52.50	52.50
L-Leucine	52.40	52.50	52.00	52.50	52.50	52.50	52.50	52.50	52.50	52.50	52.50
L-Lysine • HCl	73.10	72.50	72.50	72.50	73.06	72.50	72.50	72.50	72.50	72.50	72.50
L-Methionine	15.00	15.00	15.00	15.00	14.90	15.00	15.00	15.00	15.00	15.00	15.00
L-Phenylalanine	33.00	32.50	32.00	32.50	33.02	32.50	32.50	32.50	32.50	32.50	32.50
L-Proline	--	--	--	11.50	--	--	11.50	--	--	--	--
L-Serine	--	--	--	10.50	--	--	10.50	--	--	--	--
L-Threonine	47.60	47.60	48.00	47.60	47.64	47.60	47.60	47.60	47.60	47.60	47.60
L-Tryptophan	8.00	10.00	10.00	10.00	10.20	10.00	10.00	10.00	10.00	10.00	10.00
L-Tyrosine • 2Na • 2H <sub>2</sub> O	52.19	51.90	51.90	51.90	--	51.90	51.90	51.90	51.90	51.90	51.90
L-Tyrosine, free base	--	--	--	--	36.00	--	--	--	--	--	--
L-Valine	46.80	46.80	46.00	46.80	46.90	46.80	46.80	46.80	46.80	46.80	46.80
<i>Vitamins</i>											
Choline bitartrate	--	--	--	--	1.80	--	--	--	--	--	--
D-Calcium pantothenate	2.00	1.00	1.00	1.00	1.00	1.00	1.00	1.00	1.00	1.00	1.00
Choline chloride	2.00	1.00	1.00	1.00	--	1.00	1.00	1.00	1.00	1.00	1.00
Folic acid	2.00	1.00	1.00	1.00	1.00	1.00	1.00	1.00	1.00	1.00	1.00
<i>D</i> -Inositol	3.60	2.00	2.00	2.00	2.00	2.00	2.00	2.00	2.00	2.00	2.00
Nicotinamide	2.00	1.00	1.00	1.00	1.00	1.00	1.00	1.00	1.00	1.00	1.00
Pyridoxine • HCl	2.00	1.00	1.00	1.00	1.00	1.00	1.00	1.00	1.00	1.00	1.00
Riboflavin	0.20	0.10	0.10	0.10	0.10	0.10	0.10	0.10	0.10	0.10	0.10
Thiamine • HCl	2.00	1.00	1.00	1.00	1.00	1.00	1.00	1.00	1.00	1.00	1.00
<i>Other</i>											
D-Glucose	4500	1000	1000	1000	1000	1000	1000	4500.00	1000.00	1000.00	1000.00
Phenol red • Na	15.00	10.00	10.00	10.00	6.00	10.00	10.00	15.00	10.00	10.00	--
Succinic acid	--	--	--	--	75.00	--	--	--	--	--	--
Sodium Pyruvate	--	--	--	--	--	--	110.00	--	--	--	--
<i>Add</i>											
NaHCO <sub>3</sub>											
Powder (g/L)	2.75	2.20	--	2.20	2.20	2.20	--	--	--	--	--
7.5% Solution (mL/L)	33.40	26.70	--	26.70	26.70	26.70	--	--	--	--	--
L-Glutamine											
Powder (mg/L)	--	--	--	--	292.00	292.00	--	--	--	--	--
200 mM Solution (mL/L)	--	--	--	--	10.00	10.00	--	--	--	--	--

## Penicillin Streptomycin Solutions

Cat. No.	30-001	30-002	30-009
Description	Liquid, 50x	Liquid, 100x	Liquid, 100x
Units	g/L	g/L	g/L

Components			
Penicillin G • potassium salt	5,000,000 U/L	10,000,000 U/L	10,000,000 U/L
Streptomycin sulfate	5.0	10.0	10.0
L-Glutamine	--	--	29.2
Sodium citrate dihydrate	--	--	2.582
NaCl	--	--	1.4

## Trace Elements

Cat. No.	25-021	25-022	25-023
Description	(A) 1000x	(B) 1000x	(C) 1000x
Units	mg/L	mg/L	mg/L

Components			
CuSO <sub>4</sub> • 5H <sub>2</sub> O	1.60	--	--
ZnSO <sub>4</sub> • 7H <sub>2</sub> O	863.00	--	--
Selenite • 2Na	17.30	--	--
Ferric citrate	1155.10	--	--
MnSO <sub>4</sub> • H <sub>2</sub> O	--	0.17	--
Na <sub>2</sub> SiO <sub>3</sub> • 9H <sub>2</sub> O	--	140.00	--
Molybdic acid, ammonium salt	--	1.24	--
NH <sub>4</sub> VO <sub>3</sub>	--	0.65	--
NiSO <sub>4</sub> • 6H <sub>2</sub> O	--	0.13	--
SnCl <sub>2</sub> (anhydrous)	--	0.12	--
AlCl <sub>3</sub> • 6H <sub>2</sub> O	--	--	1.20
AgNO <sub>3</sub>	--	--	0.17
Ba(C <sub>2</sub> H <sub>3</sub> O <sub>2</sub> ) <sub>2</sub>	--	--	2.55
KBr	--	--	0.12
CdCl <sub>2</sub>	--	--	2.28
CoCl <sub>2</sub> • 6H <sub>2</sub> O	--	--	2.38
CrCl <sub>3</sub> (anhydrous)	--	--	0.32
NaF	--	--	4.20
GeO <sub>2</sub>	--	--	0.53
KI	--	--	0.17
RbCl	--	--	1.21
ZrOCl <sub>2</sub> • 8H <sub>2</sub> O	--	--	3.22

**Trypsin and Trypsin/EDTA Solutions**

Cat. No.	25-050	25-051	25-052	25-053	25-054
Description	Liquid, 1x 0.25% Trypsin in HBSS	Liquid, 1x 0.05% Trypsin 0.53 mM EDTA in HBSS	Liquid, 1x 0.05% Trypsin 0.53 mM EDTA in HBSS	Liquid, 1x 0.25% Trypsin 2.21 mM EDTA in HBSS	Liquid, 10x 2.5% Trypsin in HBSS
Units	mg/L	mg/L	mg/L	mg/L	mg/L

Components					
D-Glucose	1000.00	1000.00	1000.00	1000.00	1000.00
EDTA • 4Na • 2H <sub>2</sub> O	--	221.00	221.00	920.00	--
KCl	400.00	400.00	400.00	400.00	400.00
KH <sub>2</sub> PO <sub>4</sub>	60.00	60.00	60.00	60.00	60.00
NaCl	8000.00	8000.00	8000.00	8000.00	8000.00
NaHCO <sub>3</sub>	350.00	350.00	--	--	350.00
Na <sub>2</sub> HPO <sub>4</sub> (anhydrous)	47.70	47.70	47.70	47.70	47.50
Phenol red • Na	10.00	10.00	10.00	10.00	--
Trypsin 1:250	2500.00	500.00	500.00	2500.00	25000.00

**Tryptic Soy Broth**

Cat. No.	46-060	61-411
Description	Liquid, 1x	Powder
Units	g/L	g/L

Components		
Non-animal origin peptone	20.0	20.0
Dextrose	2.5	2.5
NaCl	5.0	5.0
K <sub>2</sub> HPO <sub>4</sub>	2.5	2.5

**Trypan Blue**

Cat. No.	25-900
Description	0.4% Solution
Units	g/L

Components	
Trypan blue	4.0
NaCl	8.10
K <sub>2</sub> HPO <sub>4</sub>	0.60

## RPMI 1640

Cat. No.	10-040	10-041	10-043	10-104	15-040	15-041	17-104	17-105	50-020	90-022
Description	Liquid, 1x	Liquid, 1x	Liquid, 1x	Liquid, 1x	Liquid, 1x	Liquid, 1x	Liquid, 1x	Liquid, 1x	Powder	Powder
Units	mg/L	mg/L	mg/L	mg/L	mg/L	mg/L	mg/L	mg/L	mg/L	mg/L

Components										
<i>Inorganic Salts</i>										
Ca(NO <sub>3</sub> ) <sub>2</sub> • 4H <sub>2</sub> O	100.00	100.00	100.00	100.00	100.00	100.00	100.00	100.00	100.00	100.00
KCl	400.00	400.00	400.00	400.00	400.00	400.00	400.00	400.00	400.00	400.00
MgSO <sub>4</sub> (anhydrous)	48.80	48.80	48.80	48.80	48.80	48.80	48.80	48.80	48.80	48.80
NaCl	6000.00	6000.00	6000.00	6000.00	6000.00	6000.00	6000.00	6000.00	6000.00	6000.00
Na <sub>2</sub> HPO <sub>4</sub> (anhydrous)	800.70	800.70	800.70	800.70	800.70	800.70	800.70	800.70	800.70	800.70
NaHCO <sub>3</sub>	2000.00	2000.00	2000.00	2000.00	2000.00	2000.00	2000.00	2000.00	--	--
<i>Amino Acids</i>										
L-Arginine	200.00	200.00	200.00	200.00	200.00	200.00	200.00	200.00	200.00	200.00
L-Asparagine • H <sub>2</sub> O	56.82	56.82	56.82	56.82	56.82	56.82	56.82	56.82	56.82	56.82
L-Aspartic acid	20.00	20.00	20.00	20.00	20.00	20.00	20.00	20.00	20.00	20.00
L-Cystine • 2HCl	65.20	65.20	65.20	65.20	65.20	65.20	--	65.20	65.20	65.20
L-Glutamic acid	20.00	20.00	20.00	20.00	20.00	20.00	20.00	20.00	20.00	20.00
L-Glutamine	300.00	300.00	300.00	300.00	--	--	--	--	300.00	--
Glycine	10.00	10.00	10.00	10.00	10.00	10.00	10.00	10.00	10.00	10.00
L-Histidine	15.00	15.00	15.00	15.00	15.00	15.00	15.00	15.00	15.00	15.00
Hydroxy-L-proline	20.00	20.00	20.00	20.00	20.00	20.00	20.00	20.00	20.00	20.00
L-Isoleucine	50.00	50.00	50.00	50.00	50.00	50.00	50.00	50.00	50.00	50.00
L-Leucine	50.00	50.00	50.00	50.00	50.00	50.00	50.00	50.00	50.00	50.00
L-Lysine • HCl	40.00	40.00	40.00	40.00	40.00	40.00	40.00	40.00	40.00	40.00
L-Methionine	15.00	15.00	15.00	15.00	15.00	15.00	--	15.00	15.00	15.00
L-Phenylalanine	15.00	15.00	15.00	15.00	15.00	15.00	15.00	15.00	15.00	15.00
L-Proline	20.00	20.00	20.00	20.00	20.00	20.00	20.00	20.00	20.00	20.00
L-Serine	30.00	30.00	30.00	30.00	30.00	30.00	30.00	30.00	30.00	30.00
L-Threonine	20.00	20.00	20.00	20.00	20.00	20.00	20.00	20.00	20.00	20.00
L-Tryptophan	5.00	5.00	5.00	5.00	5.00	5.00	5.00	5.00	5.00	5.00
L-Tyrosine • 2Na • 2H <sub>2</sub> O	28.83	28.83	28.83	28.83	28.83	28.83	28.83	28.83	28.83	28.83
L-Valine	20.00	20.00	28.83	28.83	20.00	20.00	20.00	20.00	20.00	20.00
<i>Vitamins</i>										
Biotin	0.20	0.20	0.20	0.20	0.20	0.20	0.20	0.20	0.20	0.20
D-Calcium pantothenate	0.25	0.25	0.25	0.25	0.25	0.25	0.25	0.25	0.25	0.25
Choline chloride	3.00	3.00	3.00	3.00	3.00	3.00	3.00	3.00	3.00	3.00
Folic acid	1.00	1.00	1.00	1.00	1.00	1.00	1.00	1.00	1.00	1.00
<i>i</i> -Inositol	35.00	35.00	35.00	35.00	35.00	35.00	35.00	35.00	35.00	35.00
Nicotinamide	1.00	1.00	1.00	1.00	1.00	1.00	1.00	1.00	1.00	1.00
Para-Aminobenzoic acid	1.00	1.00	1.00	1.00	1.00	1.00	1.00	1.00	1.00	1.00
Pyridoxine • HCl	1.00	1.00	1.00	1.00	1.00	1.00	1.00	1.00	1.00	1.00
Riboflavin	0.20	0.20	0.20	0.20	0.20	0.20	0.20	0.20	0.20	0.20
Thiamine • HCl	1.00	1.00	1.00	1.00	1.00	1.00	1.00	1.00	1.00	1.00
Vitamin B <sub>12</sub>	0.005	0.005	0.005	0.005	0.005	0.005	0.005	0.005	0.005	0.005

FORMULATIONS

**RPMI 1640** (continued)

Cat. No.	10-040	10-041	10-043	10-004	15-040	15-041	17-104	17-105	50-020	90-022
Description	Liquid, 1x	Liquid, 1x	Liquid, 1x	Liquid, 1x	Liquid, 1x	Liquid, 1x	Liquid, 1x	Liquid, 1x	Powder	Powder
Units	mg/L	mg/L	mg/L	mg/L	mg/L	mg/L	mg/L	mg/L	mg/L	mg/L
<i>Other</i>										
D-Glucose	2000.00	2000.00	--		2000.00	2000.00	2000.00	2000.00	2000.00	2000.00
Glutathione (reduced)	1.00	1.00	1.00		1.00	1.00	1.00	1.00	1.00	1.00
HEPES	--	5958.00	--		--	5958.00	--	--	--	--
Phenol red • Na	5.00	5.00	5.00		5.00	5.00	5.00	--	5.00	--
<i>Add</i>										
NaHCO <sub>3</sub>										
Powder (g/L)	--	--	--		--	--	--	--	2.00	2.00
7.5% Solution (mL/L)	--	--	--		--	--	--	--	26.70	26.70
L-Glutamine										
Powder (mg/L)	--	--	--		300.00	300.00	300.00	300.00	--	300.00
200 mM Solution (mL/L)	--	--	--		10.27	10.27	10.27	10.27	--	10.27



# Alphabetical Index

## A

Amino acids and vitamins	22
Amphotericin B	23
Ampicillin, sodium salt	23, 30
Antibiotic-Antimycotic solution	23

## B

Blasticidin S HCl	23
Buffers	25, 31
Buffered salt solutions	12

## C

Carbenicillin, disodium salt	30
Cell expansion bags	42
Cellstripper™ Solution	26
Charcoal-stripped FBS	20
Chloramphenicol	23
Ciprofloxacin hydrochloride	23
Classical media	6
CMRL 1066	8
Collection containers	36, 37
Cryopreservation bags	39

## D

Dialyzed FBS	20
Dimethyl Sulfoxide (DMSO)	26
DMEM	6
DMEM/Ham's F-12 50/50 mix	7
Donor calf serum	20
Donor horse serum	20
DPBS	12

## E

EDTA	32
ES Cell-tested FBS	20

## F

F-12K nutrient mixture	7
Fetal bovine serum (FBS)	20

## G

G418 sulfate	23
Gamma-Irradiated FBS	20
Gentamicin Sulfate	24
Glasgow's MEM	7
Glucose solution	26
glutagro™ Supplement	22
Grace's Insect Basal Medium	18

## H

Ham's F-10 medium	7
Ham's F-12 medium	7
HBSS	13
HAT	26
Hepatocyte maintenance medium	17
HEPES	25
Hink's TNM-FH medium	18
HT	26
Human AB serum	20
hybrigo SF™	17
Hygromycin B solution	24

## I

Improved MEM (Richter's Mod.)	8
insectagro DS2™	18
insectagro Sf9™	18
Insulin-Transferrin-Selenium	26
Iscove's Modification of DMEM	8
Isopropylthiogalactoside (IPTG)	31

## K

Kanamycin Sulfate	24, 30
-------------------	--------

## L

Leibovitz's L-15	8
L-Glutamine	22
Low IgG FBS	20
Lymphocyte separation medium	16

## M

McCoy's 5A	8
MCDB 131	8
Medium 199	9
MEM	9
MEM alpha medium	10
MEM amino acids	22
MEM NEAA	22
MEM vitamins	23
Miller's LB Broth	30
Molecular biology grade water	34
MOPS buffer	31

## N

Neomycin Sulfate	24, 30
------------------	--------

## P

Penicillin Streptomycin solution	24
PBS	12, 31
PF medium	20
Poloxamer 188	18
Polysucrose 400	18
Puromycin Dihydrochloride	25

## R

Reagent grade water	34
rhAlbumin	17
rhLactoferrin	17
Rocker cell culture bags	40
RPMI 1640	10

## S

Sera	20
SF Medium	16
Single-use bags	38
S.O.C. Medium	30
Sodium Acetate	32
Sodium Bicarbonate	25
Sodium Chloride	32
Sodium Dodecyl Sulfate (SDS)	32
Sodium Pyruvate	26
SSC	31
SSPE	31
stemgro® hMSC	17
Streptomycin Sulfate	24

## T

TAE	31
Tank liners	43
TBE buffer	31
TE buffer	32
Terrific Broth	30
Tetracycline Hydrochloride	25
Tetracycline negative FBS	20
Trace elements	27
transfectagro™ Medium	16
Tris base buffer	27
Tris buffered saline	32
Tris-HCl buffers	32
Trypan blue	27
Trypsin	26
Tryptic soy broth	16
Tubing sets	44

## W

Water	34
-------	----

## X

X-Gal	31
-------	----

## Y

Yeast extract	27
---------------	----

# Catalog Number Index

10-009	9	25-052	25, 68	50-051	9, 63
10-010	9, 67	25-053	25, 68	51-010	9, 66
10-013	6, 52	25-054	25, 68	55-021	13, 59
10-014	6, 52	25-055	34	55-022	13, 59
10-016	8, 60	25-056	26	55-031	12, 51
10-017	6, 52	25-060	25, 58	61-030	22
10-022	10, 50	25-065	34	61-034	25
10-024	8, 59	25-072	16, 60	61-065	25
10-025	7, 55	25-800	26, 60	61-088	24, 30
10-026	8, 59	25-900	27, 68	61-098	24
10-027	6	25-950	26	61-161	18
10-040	10, 69	30-001	24, 67	61-176	24, 30
10-041	10, 69	30-002	24, 67	61-231	27
10-043	10, 69	30-003	23, 67	61-233	27
10-045	8, 61	30-004	23	61-234	23
10-050	8, 61	30-005	24	61-238	23
10-051	8, 61	30-006	30, 24	61-239	23, 30
10-060	9, 63	30-009	24	61-241	24, 30
10-070	7, 57	30-100	23	61-242	25, 31
10-080	7, 58	30-234	23	61-277	23
10-090	7, 54	30-240	24	61-385	24
10-092	7, 54	35-010	20	61-411	16, 68
10-101	6, 52	35-011	20	61-196	18
10-102	6, 52	35-015	20	62-450	17
10-103	7, 54	35-016	20	62-451	17
10-104	10	35-022	20	90-001	37
13-100	18, 56	35-030	20	90-002	37
13-200	18, 56	35-060	20	90-009	9, 66
13-402	18	35-070	20	90-013	6, 53
13-410	18	35-071	20	90-022	10, 69
13-901	18	35-072	20	90-050	9, 63
15-010	9, 67	35-073	20	90-090	7, 54
15-012	10, 50	35-074	20	90-091	7, 54
15-013	6, 52	35-075	20	90-113	6, 53
15-015	9, 67	40-101	16	91-100	37
15-016	8, 60	40-102	16	90-200-01	36
15-017	6, 52	40-200	16	90-200-02	36
15-018	6, 52	40-300	16	90-200-05	36
15-040	10, 69	40-202	17	90-200-10	36
15-041	10, 69	40-215	17	90-200-20	36
15-090	7	40-410	17	90-200-36	36
15-100	8, 62	40-550	17	90-200-39	36
15-110	8, 51	46-000	34	90-200-41	36
16-405	7, 54	46-002	34	90-200-42	36
17-104	10, 69	46-003	30, 65	90-200-43	36
17-105	10, 69	46-009	32, 65	90-200-45	36
17-204	6, 52	46-010	31, 65	90-200-47	36
17-205	6, 53	46-011	31, 65	90-200-48	36
17-206	6, 53	46-012	32, 51	90-200-75	43
17-207	6, 53	46-013	31, 51	90-200-76	43
17-305	9, 67	46-020	31, 65	90-200-77	43
20-021	13, 59	46-021	31	90-200-78	40
20-023	13, 59	46-030	32, 65	90-200-79	41
20-030	12, 51	46-031	32, 65	90-200-80	41
20-031	12, 51	46-032	32	90-200-81	42
21-020	13, 59	46-033	32	90-200-82	37
21-021	13, 59	46-034	32	90-200-83	37
21-022	13, 59	46-040	32	90-200-84	38
21-023	13, 59	46-050	30, 65	90-200-85	38
21-030	12, 51	46-055	30, 65	90-200-86	38
21-031	12	46-060	16, 65, 68	90-200-87	38
21-040	12, 51	46-100	30	90-200-88	39
25-000	26	46-101	31	90-200-89	39
25-005	22, 55	46-102	31	90-200-90	39
25-015	22, 55	46-103	31	90-200-91	39
25-020	22, 64	50-003	6, 53	90-200-92	40
25-021	27, 67	50-004	7, 66	90-300-15	43
25-022	27, 67	50-010	9, 66	90-300-20	43
25-023	27, 67	50-011	9, 66	90-300-25	43
25-025	22, 64	50-012	10, 50	90-300-30	43
25-030	22, 64	50-013	6, 53	90-300-35	43
25-035	25	50-016	8, 60	90-300-80	43
25-037	26	50-019	8, 66	90-700-00	42
25-046	26, 58	50-020	10, 69	90-700-04	42
25-047	26, 58	50-040	7, 58	90-700-12	42
25-050	25, 68	50-045	8, 61		
25-051	25, 68	50-050	9, 63		



[www.corning.com/lifesciences/solutions](http://www.corning.com/lifesciences/solutions)

At Corning, we continuously strive towards improving efficiencies and developing new products and technologies for life science researchers. We have scientists working in Corning R&D labs across the globe, doing what you do every day. Our technical experts understand your challenges and your increased need for high-quality products.

It is this expertise, plus a 160-year legacy of Corning innovation and manufacturing excellence, that puts us in a unique position to be able to offer a beginning-to-end portfolio of high-quality, reliable life sciences consumables.

**Warranty/Disclaimer:** Unless otherwise specified, all products are for research use only. Not intended for use in diagnostic or therapeutic procedures. Not for use in humans. Corning Life Sciences makes no claims regarding the performance of these products for clinical or diagnostic applications.

For additional product or technical information, and a complete listing of our International Offices and Distributors, please visit [www.corning.com/lifesciences](http://www.corning.com/lifesciences) or call 800.492.1110. Outside the United States, please call +1.978.442.2200 or contact your local Corning sales office listed below.

**Mediatech, Inc.**

*A Corning Subsidiary*

9345 Discovery Boulevard  
Manassas, VA 20109-3992

t 800.235.5476

t 703.471.5955

f 703.467.9851

[www.corning.com/lifesciences/media](http://www.corning.com/lifesciences/media)

[www.corning.com/lifesciences](http://www.corning.com/lifesciences)

**Worldwide  
Support Offices**

**ASIA/PACIFIC**

**Australia/New Zealand**  
t 0402-794-347

**China**

t 86 21 2215 2888

f 86 21 6215 2988

**India**

t 91 124 4604000

f 91 124 4604099

**Japan**

t 81 3-3586 1996

f 81 3-3586 1291

**Korea**

t 82 2-796-9500

f 82 2-796-9300

**Singapore**

t 65 6733-6511

f 65 6861-2913

**Taiwan**

t 886 2-2716-0338

f 886 2-2516-7500

**EUROPE**

**France**

t 0800 916 882

f 0800 918 636

**Germany**

t 0800 101 1153

f 0800 101 2427

**The Netherlands**

t 31 20 655 79 28

f 31 20 659 76 73

**United Kingdom**

t 0800 376 8660

f 0800 279 1117

**All Other European  
Countries**

t 31 (0) 20 659 60 51

f 31 (0) 20 659 76 73

**LATIN AMERICA**

**Brazil**

t (55-11) 3089-7419

f (55-11) 3167-0700

**Mexico**

t (52-81) 8158-8400

f (52-81) 8313-8589

**CORNING** | **FALCON**® **AXYGEN**® **PYREX**® **GOSELIN**™

For a listing of trademarks, visit us at [www.corning.com/lifesciences/media/about-us/trademarks.html](http://www.corning.com/lifesciences/media/about-us/trademarks.html)  
All other trademarks in this document are the property of their respective owners.