

HL80M Dri-Prime® Pumps

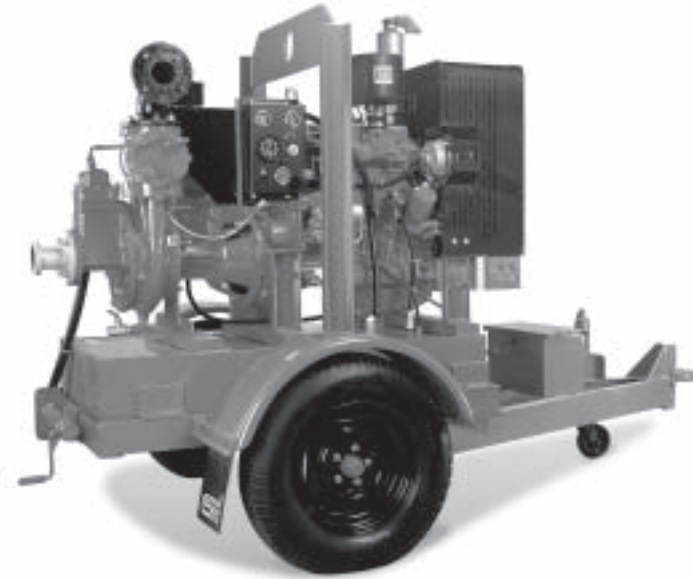

The HL80M Dri-Prime 4" x 3" (100mm x 75mm) centrifugal pump is unique in the portable pumping industry. It's like having two pumps in one. *High pressure discharge* capabilities to 150 psi (10.3 BAR) make the HL80M perfect for closed system pumping, water main testing, and wellpoint jetting. The HL80M also can be used as a typical open trench *solids handling* trash pump with no changing of parts. Constructed of hardened alloys for long life in rugged applications, a combination of automatic self-priming, solids handling and high pressure capabilities, make the HL80M Dri-Prime perfect for mines, quarries and industrial use.

Features

- Close coupled automatic self-priming 4" x 3" (100mm x 75mm) centrifugal pump with vacuum priming compressor mounted to a diesel engine. Available in electric drive or as bare shaft pumpend.
- All cast iron construction with cast chromium steel impeller. Also available in stainless steel and hardened steel alloy.
- Extensive application flexibility — will handle slurries and liquids with solids up to 1" (25mm) in diameter.
- Continuously operated "Godwin" air ejector priming device requiring no form of periodic adjustment or control.
- Dry running, oil bath, mechanical seal with abrasion resistant solid silicon carbide interfaces.
- Solids handling ball type Non Return valve with renewable flexible rubber seat and quick release access feature.
- Compact unit mounted on skid base or two wheeled highway trailer, both incorporating integral overnight running fuel tank.
- Simple maintenance — normally limited to checking engine oil and seal cavity oil levels.
- Standard John Deere 4045D or Caterpillar 3054NA engine. Also available with a variety of other engines including Hatz and Deutz.
- A variety of silenced units are available.

SOLD BY



AQUOSIS
FLUID SOLUTIONS

info@aquosis.com
1.877.907.7852

HL80M Performance Curve

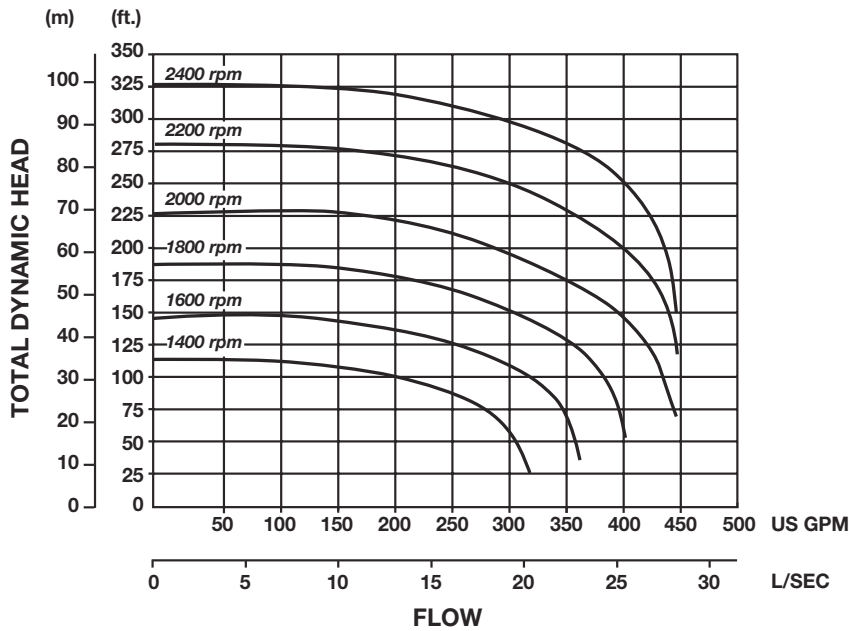

Performance Table

Diesel Set: John Deere 4045D, 71 hp (53 kw) @ 2400 rpm
 Caterpillar 3054NA, 77 hp (57 kw) @ 2400 rpm
Impeller Diameter: 12-4/5 inches (325 mm)

Total Suction Head – Feet	Total Delivery Head – Feet					
	100	150	200	225	250	300
	Output – GPM					
10	465	460	455	450	420	325
15	465	460	450	410	390	320
20	465	450	420	400	380	320
25	465	420	400	385	360	300

Performance data listed in table and curves based on water tests at sea level and 68° F (20° C). Larger diameter pipes may be required for maximum flows.

Dimensions

HL80M — Shown with John Deere 4045D, GP60 Highway Trailer
 Weight: 2,800 lbs. (1,267 kg.)

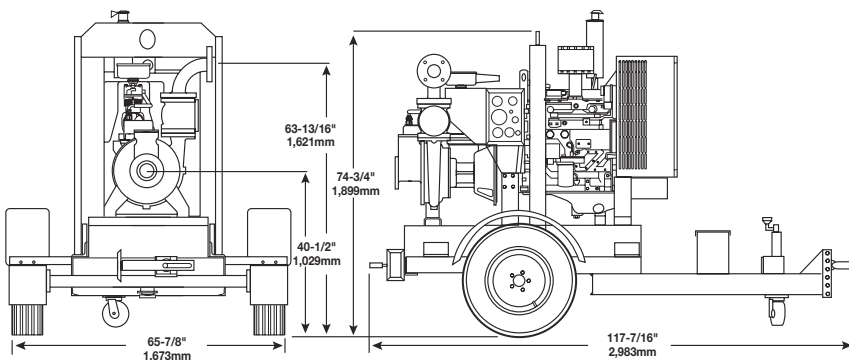

Specifications

- Maximum Operating Speed:** 2400 rpm
- Maximum Operating Temperature:** +212°F (100°C)
- Maximum Working Pressure:** 155.0 psi (10.7 BAR)
- Maximum Suction Pressure:** 40 psi (2.8 BAR)
- Maximum Casing Pressure:** 232.0 psi (16.0 BAR)
- Fuel Tank Capacity:** 60 gallons (227 litres)
- Fuel Consumption:** John Deere 4045D: 3.82 gph (14.46 lph) max.
Caterpillar 3054NA: 4.54 gph (17.18 lph) max.
- Pipe Connections:** 4" (100mm) Suction ASA 150#
3" (75mm) Discharge ASA 150#
- Solids Handling:** 1" (25mm) diameter

Materials

- Pump Casing, Suction Cover, Separation Tank and Wearplates:** Close Grained Cast Iron
- Impeller:** Cast Chromium Steel hardened to minimum Brinell 341 HB
- Shaft:** 1-1/2% Nickel/Chromium Steel
- Non Return Valve Body & Ejector Housing:** Close Grained Cast Iron
- Non Return Valve Ball:** High Nitrile Rubber
- Mechanical Seal Faces:** Solid Silicon Carbide



Aquatech has two facets to help you with your site specific needs.

For all your Rental and Sales needs call

Aquatech Pump and Power

Phone: 905-907-7852

Fax: 905-907-1701

For full "turn-key" contracting solutions call

Aquatech Dewatering Company

Phone: 905-907-1700

Fax: 905-907-1701

Email us: info@aquatd.com

69 Connie Crescent Concord, ON L4K 1L3

www.aquatd.ca

Dri-Prime® and the color orange for pumps are registered trademarks of Godwin Pumps of America, Inc. Specifications and illustrations are subject to revision without notice. © Copyright 2002-2003 Godwin Pumps of America, Inc.

GPASL-022.905

SOLD BY



info@aquosis.com
1.877.907.7852