

Fluid Transfer Technology

- Fuel & Liquid Transfer Pumps
- Meters
- Nozzles
- Dispensers
- Hoses
- Dry Break Couplers
- Spill free Couplings
- Liquid Monitoring
- Earth & Monitoring Systems
- Dipping equipment and systems
- Tanker & Terminal Equipment

Pneumatics & Automation Parts

- Cylinders
- Valves
- Actuators
- Pneumatic Fittings
- Sensors
- Air Service Units
- Vacuum Technology
- Vibration Control
- Manipulation Units
- Tubing

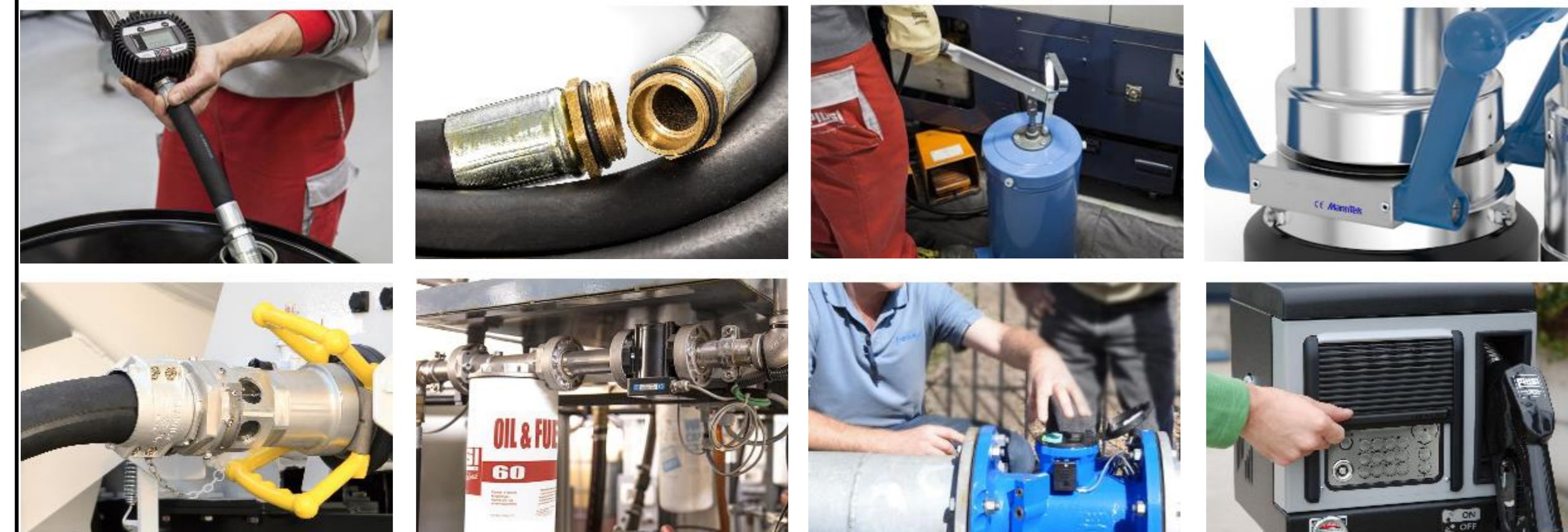

APG
INDUSTRIAL



Fluid Transfer Technology

METER SYSTEMS



MECLUBE

PIUSI

MannTek

LIQUIP
PART OF OPW a DOVER company

silea



KALYMNOS

McCabe

ProFlow

ALPTEC

Our Brands



Our Markets

- Automotive Workshop
- Agricultural
- Mining
- Retail
- Tanker and Terminal
- Transport
- OEM
- Marine
- Aviation
- Fuel Distributors
- Chemical

Our Products

- Fuel & Liquid Transfer Pumps
- Meters
- Nozzles
- Hoses
- Dip equipment and systems
- Spill free Couplings
- Liquid Monitoring
- Earth & Monitoring Systems
- Bulk Fluid Handling
- Hose and Cable Reels



PIUSI provides professional, easy-to-use and performant fluid handling equipment

Our pumps, flow meters, dispensing instruments and accessories are used all over the world in a wide range of applications

Innovation and quality
Made in Italy



RAASM equipment has been designed and tested to be used across numerous sectors, including automotive, industry, agriculture, mining, the chemical industry, shipping, offshore and in the cleaning sector. Other types of use can be discussed with our technicians and made possible thanks to specific applications that make use of highly technological materials.



Meter Systems is an APG Private Label Brand

Recognized for reliability and quality, whilst very affordable

Strong Brand Pedigree in SA Market



Pro Flow is a APG brand with NRCS approvals geared towards quality bulk fuel transfer equipment. Through innovation and constant development Pro Flow has become synonymous with affordable quality pumps, meters, and related equipment



We strongly believe in connections. Since 1997 we have developed, produced and manufactured innovative coupling products such as breakaway couplings, dry disconnect couplings, dry gas couplings and LNG solutions for some of the world's most demanding industries when it comes to safety. That means solutions beyond expectations – all the way



Liquip supplies equipment for storing and transferring bulk liquids such as petroleum and dry bulk. We specialise in terminal, tanker and aviation markets, offering best-in-class products such as loading arms, ground monitors, meters and pumping systems



Meclube studies and develops lubrication equipment entirely made in Italy for all international markets.

The great variety of solutions available and the impeccable quality of the internal production make Meclube the ideal partner in the following fields: automotive, agricultural, earth-moving, industrial and mining.



Established in 1996, Alptec Safety Equipment Co., Ltd specializes in the design, manufacture, and supply of high-quality Overfill Protection as well as Static Grounding Systems and Earthing Clamps, Reels and accessories for the chemical, petrochemical, oil and gas and process industries that transport, store, transfer and use solvents or combustible liquids in hazardous areas



Water finding and Dipping paste
The J.H. McCabe Company began in the 1930's through the ingenuity of our grandfather, Joseph S. H. McCabe Sr. From inception, all family members have played significant roles in the continuation of the development and growth of our family business. Renamed McCabe & Sons, Inc. in 1992, the company has evolved through experience



KALYMNOS

Kalymnos was founded on 1975
All fuel transfer products are certified in line with international regulations and fully conform to European standards. Strict controls are carried out during the entire production process, while a complete technical service is available for the finished product, supporting it in all stages of its installation, use and maintenance



Silea has over 50 years been helping companies to solve the problem of liquid transfer (hydrocarbons, industrial liquids, chemicals and food).
Silea designs and produces standard and customizable products for your every need. This is the goal of Sileas daily commitment.

Automotive



Workshops
Dealerships
Wholesalers
OE
Manufacturers

Tanker & Terminal



Tanker
Fuel Terminals
Bulk Terminals

Transport



Automotive
Railway
Aviation
Airports
Marine

OEM



Original
Equipment
Manufacturers

Fuel Distributors



Fuel and Diesel
Distribution

Mining & Construction



Civils
Mines
Mining Supply
Houses
Mining
Contractors

Agriculture



Co-Ops
Commercial
Farmers
Broad
Agricultural
Sector

Military



Military

Industrial



Mechanical
Chemical
Tanning
Wood
Marble
Manufacturing
Industry

PIUSI
®





- Since 1953, PIUSI has been a leading player in the global fluid handling sector
- Piusi supplies a complete range of products for fluid transferring and management
- Italian quality and engineering at the service of private operators in agriculture, the automotive industry, workshops and garages, fleet management, road and sea transport worldwide.
- They supply the world's leading markets with top-quality, professional and easy to use products and complete solutions for transferring, refilling and measuring lubricants, fuels and liquids such as gasoline, diesel, Diesel Exhaust Fluid (DEF), AdBlue®, oil, water and grease
- PIUSI products have many different uses such as monitoring and transferring fuel at trucking companies, refueling of agricultural vehicles, transferring fuels in construction and mining for heavy duty vehicles.





Fuel



Lubrication



AdBlue





Pumps



Meters



Hoses and Reels



Nozzles



Dispensing/ Self Service



Filters



PIUSI offers a complete, professional range of solutions for non-commercial transferring of liquids and dispensing of fuel. PIUSI AC/DC diesel transfer pumps, diesel dispensers, flow meters and diesel fuel filters satisfy the most stringent regulations regarding safety as well as the highest quality standards.

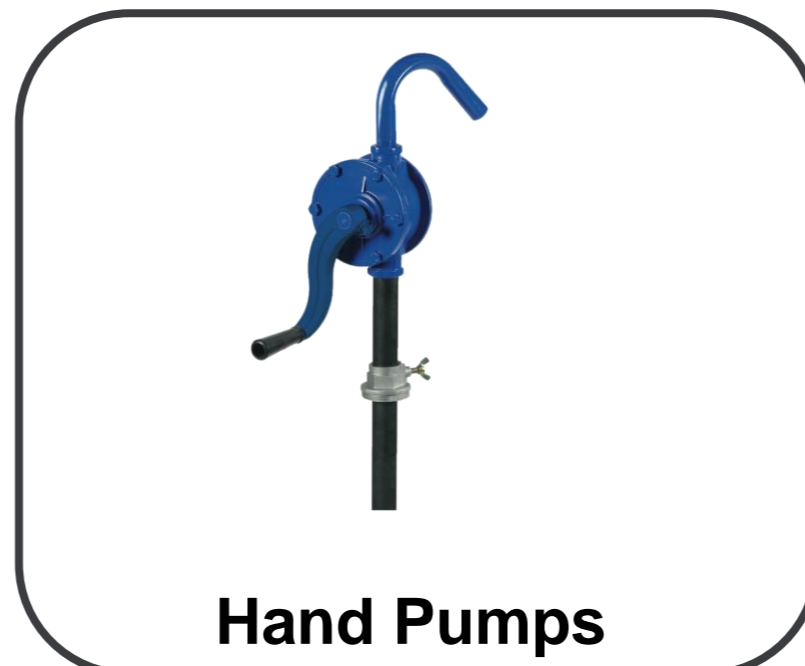
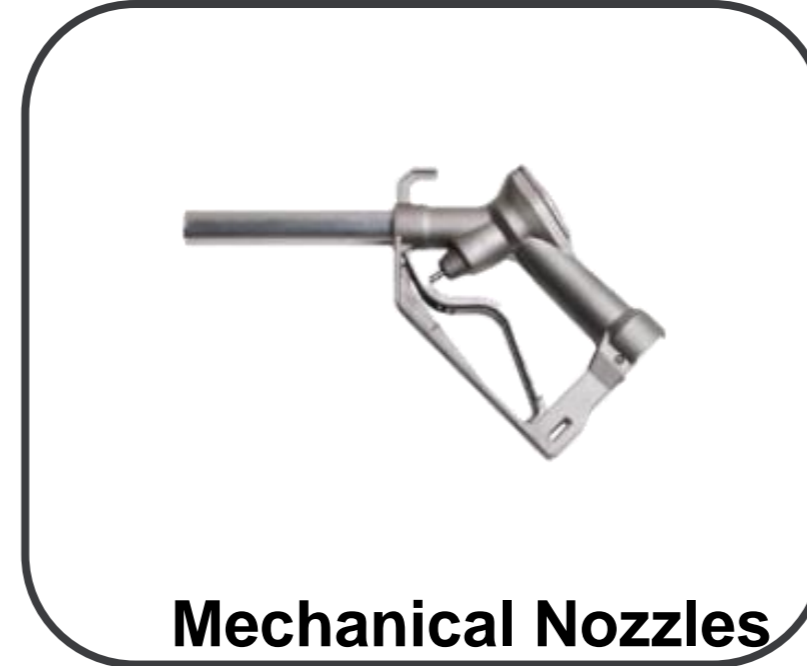
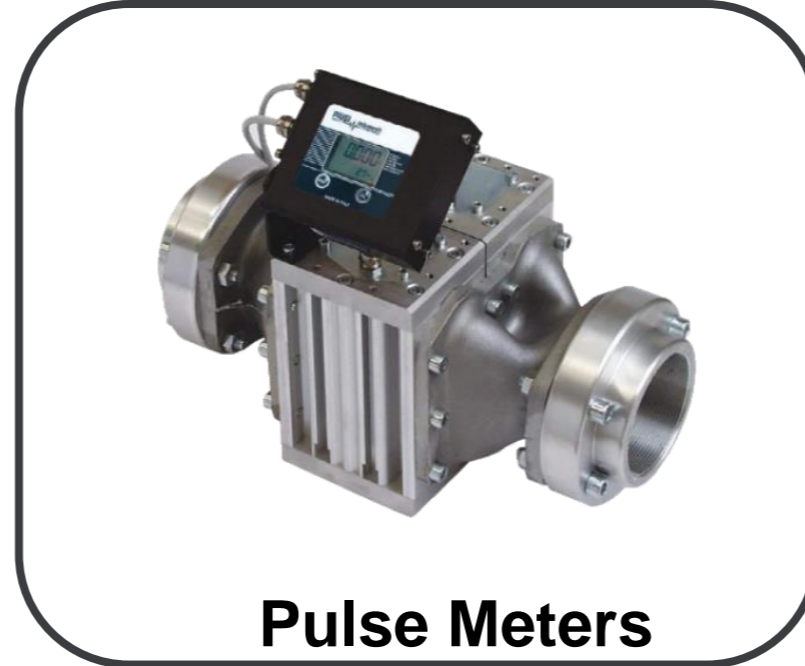
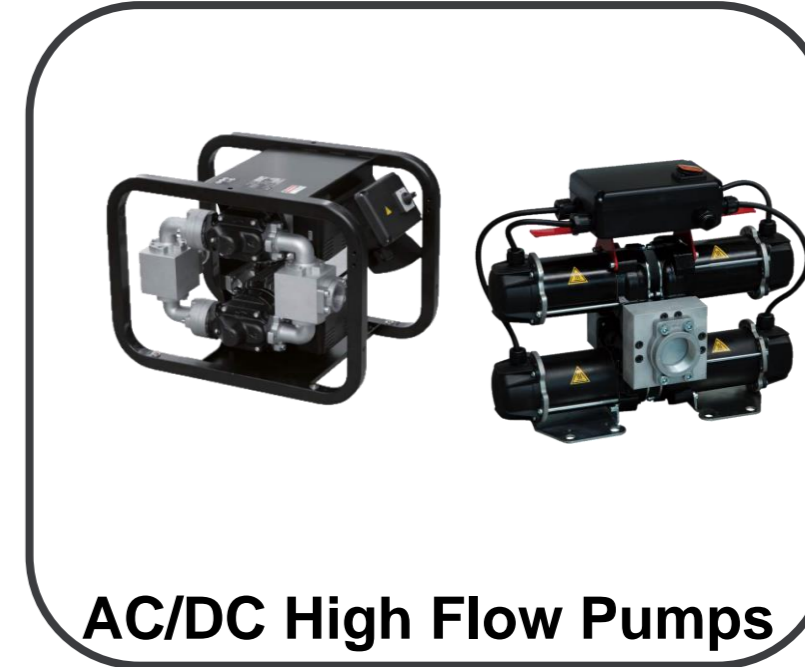

Lubrication Range

PIUSI offers a range of professional products for fluid handling applications in workshops. The range includes engine oil suction pumps, oil filtering equipment, oil transfer pumps, digital flow meters for oil and grease, and oil and grease drum pumps.



Oil Piston Pumps



AC Vane/Gear Pumps



AC / DC Transfer Pumps



Pneumatic Diaphragm Pumps



Drum Kits



Grease Drum Kits



Mechanical Meters



Metered Nozzles



Electronic Meters



Hose Reels



Oil / Grease Cart Kits



Filters



Accessories



Filtration





AC/DC Pumps



Car Suction Kits



Drum Kits



Pneumatic Diaphragm Pumps



Flow Meters



Self Service Units



Hand Drum Pumps



Hose Reels



Hose



Nozzles



Dispensing



Filtration



SSM.2.0 Consumption Control

Manage consumption and supply of fuels.



SELF SERVICE MANAGEMENT Dispensing Control

Monitoring quantity delivered.



B.SMART Dispensing Control

Monitor and manage the quantities delivered in the cloud without territorial limitations with smart technologies.

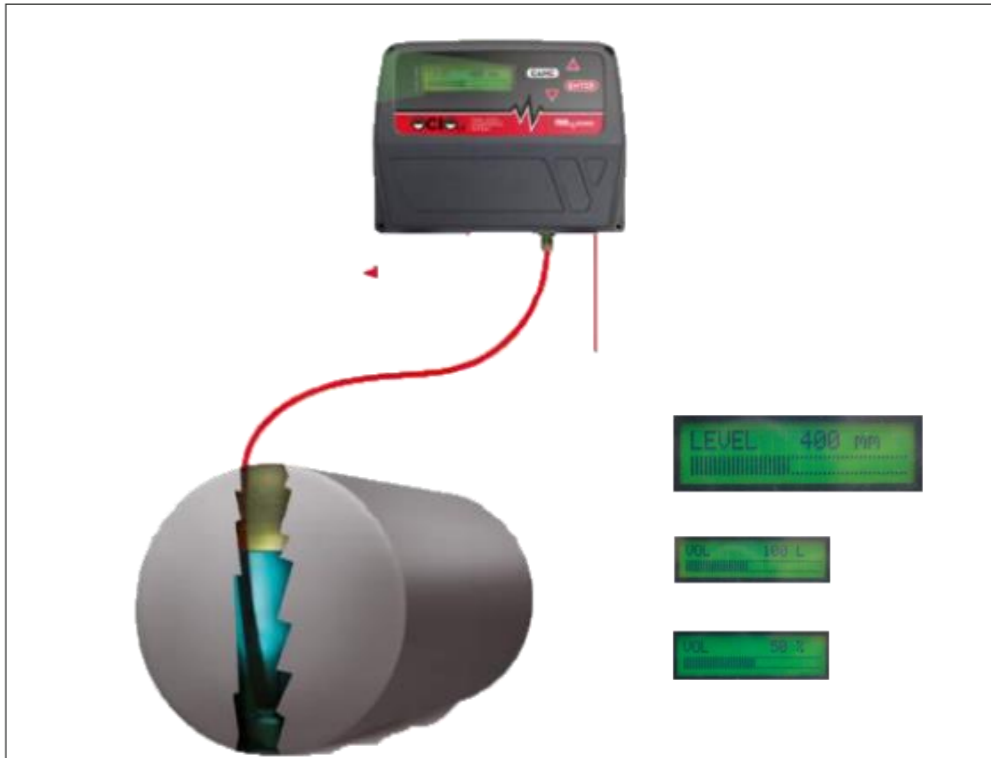

OCIO

- Any kind of fluid storage in tanks up to 4m dept.
- Real time indication
- Easy to calibrate



RAASM

RAASM



- RAASM equipment has been designed and tested to be used across numerous sectors, including automotive, industry, agriculture, mining, the chemical industry, shipping, offshore and in the cleaning sector. Other types of use can be discussed with our technicians and made possible thanks to specific applications that make use of highly technological materials.



The Typical Automotive Workshop



- Pneumatic Piston Pumps
- Oil Bars
- Service Columns
- Waste Oil Drainers
- Drip Trays
- Tyre Inflators
- Hose Reels
- Central Lubrication systems
- Grease Pumps
- Oil Stations
- Washers
- Storage

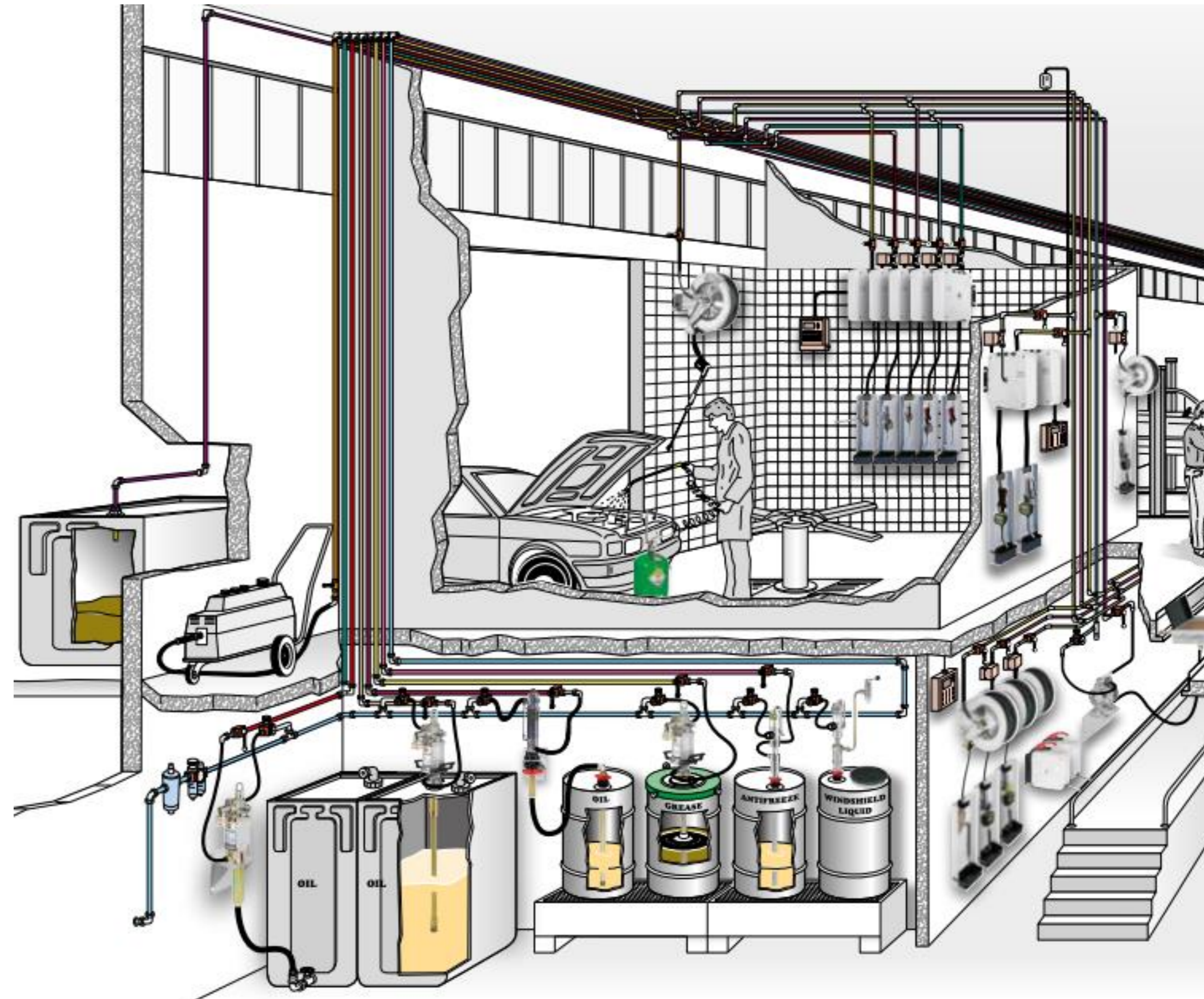

Brake Bleeding – Washing - Inflating



Brake – Clutch Bleeding



Washing Tank



Inflator Hose Reel

Waste Oil Suction / Drainers



Wheel Mounted
Suction drainers



Gravity Drainers

Oil Pumps



Diaphragm Air Pumps



Manual & Air operated drum
Pumps



Air Operated Oil Dispensers

Grease Pumps



Hand-operated grease
pump



Portable grease dispenser

Service Columns



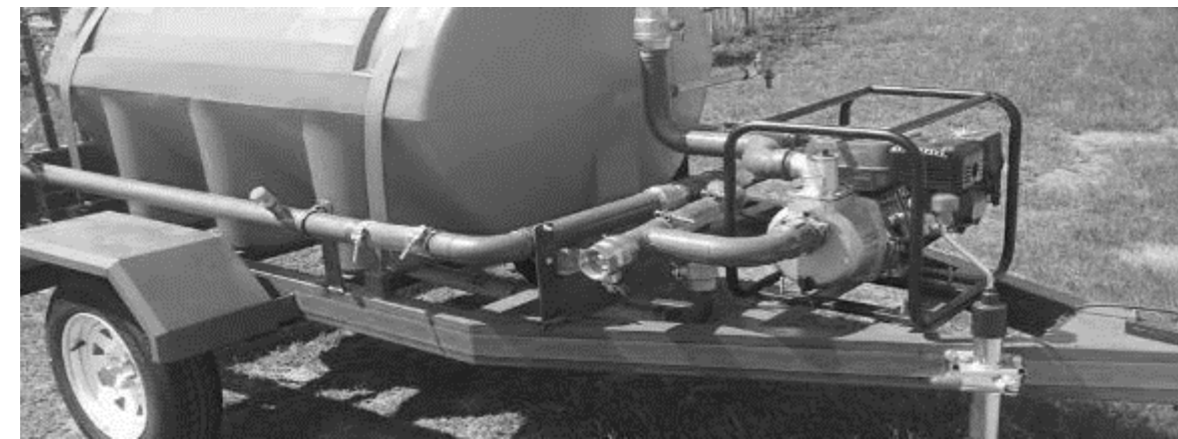

METER SYSTEMS



APG
INDUSTRIAL



METER SYSTEMS

- Meter Systems has been a trusted brand name in the fuel transfer industry for over 15 years
- Through the years there have been major developments for this brand, especially on fuel transfer equipment
- Following years of testing and development all Meter Systems designed and imported equipment carries the same warranty period as its European counter parts



Meter Systems Product Ranges

Pumps



DC Pumps



AC Pumps

Meters



Mechanical Meters



Bulk Flow Meters

Filters



Water trap Filters



Spin-on Filters

Nozzles



Manual nozzle



Automatic nozzle

Pump Sets



Compact AC pump unit

Hoses & Accessories



Dipping Equipment





Flexsteel Flextura Curbside Pump Hose



Plicord Super Black Flexwing Petrol suction and delivery hose 300 PSI



Plicord Flexwing Petroleum Petrol suction and delivery hose 150PSI



Spiraflex Polyurethane Vapour Recovery Hose

Applications

- Petrochemical
- Chemical Industry
- LPG Industry
- Agricultural
- Mining



Petroleum / Chemical Composite Hose



Farmtank Hose



Multipurpose Hose

- **Custom hoses build and fitted as per customer requirements.**
- **Pressure Testing.**
- **Pressure Test Certificate issue upon request.**
- **Hose pressure testing on-site.**



Custom built pump sets



Service and repair of diesel trailers

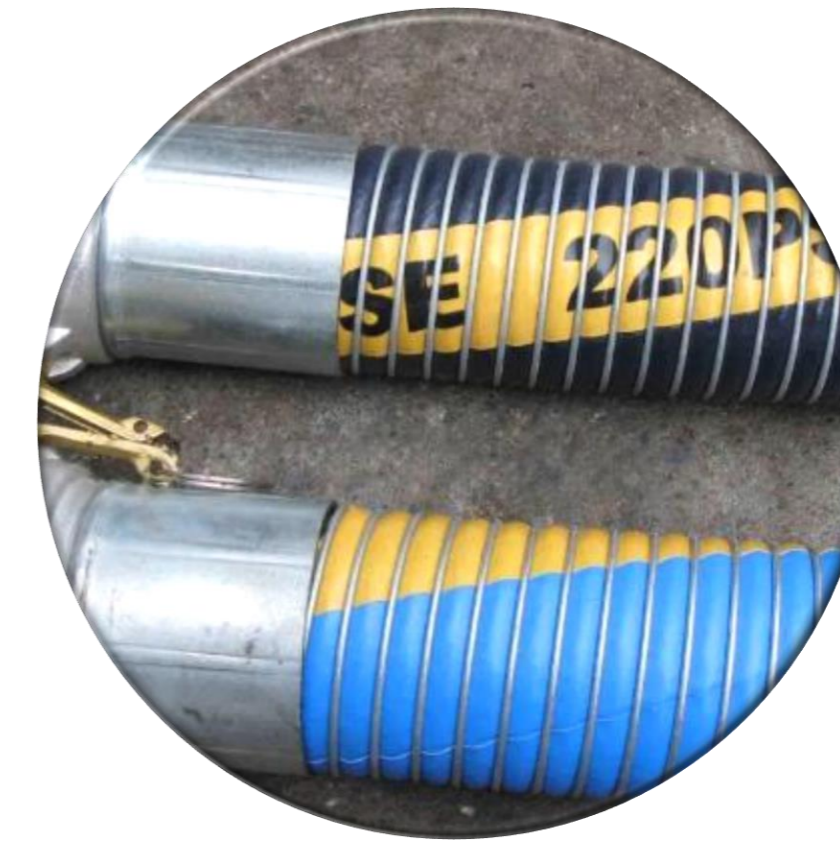

Hose Crimping



**Pressure Testing
“In house and on site”**



Diesel Trailer Rebuilds



Hose Repairs



Custom Hoses



Repairs and Rebuilds



Services offered

- Complete rebuild programs
- Diesel Trailer refurbishment
- Diesel Trailer Repairs
- Diesel Trailer Servicing – pumps, hoses, meters, calibration





METER SYSTEMS

Fluid Transfer Equipment

NEW RANGE



Agriculture



Mining / Construction



Non-commercial use

MS-YB4012V



Product Information



Material: Cast Iron
Product: Diesel and Kerosene
Inlet / Outlet: 3/4" BSP
Duty Cycle: 30 min

Rated Voltage	DC12V	DC24V
Flow Rate	20-40L/min	-
Voltage	12V DC	-
Max pressure	3 Bar	-
Inlet / Outlet	¾" BSP	-

MS-YB7012V



Product Information



Material: Cast Iron
Product: Diesel and Kerosene
Inlet / Outlet: 1" BSP
Duty Cycle: 30 min

Rated Voltage	DC12V	DC24V
Flow Rate	20-70L/min	-
Voltage	12V DC	-
Max Pressure	3 Bar	-
Inlet / Outlet	1" BSP	-

PS1229D-12V



Product Information



Material: Cast Iron
Product: Diesel and Kerosene
Inlet / Outlet: 1" BSP
Duty Cycle: 30 min
By-pass valve: Yes

Rated Voltage	DC12V	DC24V
Flow Rate	76 – 85L/MIN	76 – 85L/MIN
Voltage	12v DC	24v DC
Speed	2000RPM	2000RPM
Inlet / Outlet	1" BSP	1" BSP

* Includes 4m cable and clamp

MS-YB11012V



Product Information



Material: Cast Iron
Product: Diesel and Kerosene
Inlet / Outlet: 1 1/4" BSP
Duty Cycle: 30 min

Rated Voltage	DC12V	DC24V
Flow Rate	20-110L/min	-
Voltage	12v DC	-
Max Pressure		-
Inlet / Outlet	1¼" BSP	-

MS-YB60220V



Product Information



Material: Cast Iron
Product: Diesel and Kerosene
Inlet / Outlet: 1" BSP
Duty Cycle: None

Rated Voltage	AC 220V
Flow Rate	20-60L/min
Voltage	220v AC
Max pressure	3 Bar
Inlet / Outlet	1" BSP

MS-YB100220V



Product Information



Material: Cast Iron
Product: Diesel and Kerosene
Inlet / Outlet: 1" BSP
Duty Cycle: None

Rated Voltage	AC 220V
Flow Rate	20-100L/min
Voltage	220v AC
Max pressure	3 Bar
Inlet / Outlet	1" BSP

MS-YB150220V



Product Information



Material: Cast Iron
Product: Diesel and Kerosene
Inlet / Outlet: 1" BSP
Duty Cycle: None

Rated Voltage	AC 220V
Flow Rate	20-150L/min
Voltage	220v AC
Max pressure	3 Bar
Inlet / Outlet	1" BSP



Also available in custom kits

Part no: MS-JYB60220V

Part no: MS-JYB100220V



Product Information

JYB AC electric transfer pump set complete with 220v pump, FM120 meter, 4m hose, automatic nozzle and filter check valve for easy installation.



MS-JYB60220V	MS-JYB100220V
• Fluid: Diesel / Kerosene	• Fluid: Diesel / Kerosene
• Flow rate: 60L/min	• Flow rate: 100L/min
• Accuracy: +-2%	• Accuracy: +-2%
• Motor: 750W – 220v	• Motor: 750W – 220v
• Hose: 4m	• Hose: 4m
• Nozzle: Automatic 1"	• Nozzle: Automatic 1"
• Flow meter: FM120 Mechanical	• Flow meter: FM120 Mechanical
• Max. Pressure: 3 Bar	• Max. Pressure: 3 Bar
• Filter: Yes	• Filter: Yes

MS-FM120



Product Information

FM-120 Mechanical flow meter
 Product: Diesel
 Non-commercial use only
 Easy to install and simple to calibrate.

Specifications	
Flow Rate	20-120Lpm
Accuracy	± 1%
Working pressure	3 Bar
Inlet / Outlet	1" BSP

POM-OVALGEAR25
 POM-OVALGEAR40
 POM-OVALGEAR50



Product Information

Aluminium oval-gear meter
 Product: Wide range of fluid viscosities
 Non-commercial use only
 Exceptional levels of repeatability and durability

Specifications				
Model No.	Size	Flow rate	Accuracy	Pressure
OGM-A-25	1"	20-120Lpm	±0.5%	3.4 Bar
OGM-A-40	1.5"	25-250Lpm	±0.5%	1.8 Bar
OGM-A-50	2"	30-300Lpm	±0.5%	1.8 Bar

Also available with pulse output

MS-Automatic nozzle range



Part No	Flow rate	Size
MS-ZVACSL2DN16	60Lpm	5/8 X 3/4"
MS-ZVACSL2DN19	80Lpm	3/4 X 3/4"
MS-ZVACSL2DN1925	80Lpm	3/4 X 1"
MS-ZVACDN25HF	140Lpm	1"
MS-ZVACDN32HF	200Lpm	1 1/4"

MS-MFLO25

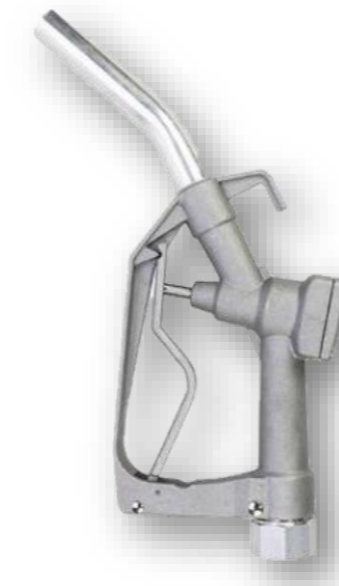

Manual Aluminium nozzle

Rated Voltage	DC12V	DC24V
Flow Rate	20-70L/min	-
Voltage	12V DC	-
Max Pressure	3 Bar	-
Inlet / Outlet	1" BSP	-

MS-TDWC-1290



Bulk automatic nozzle including swivel.

Part No	Flow rate	Size
MS-TDWC-1290	220Lpm	1.5"

MS-YB11012V



Bulk delivery nozzle – ball type – 1.5"

Part No	Description
MS-MFLO40	40mm Bulk delivery nozzle
MS-MFLO40SP	Spout for bulk nozzle
MS-MFLO40SW	Swivel for bulk nozzle

Water detection and particulate removing filter



Product Information

MS-AB25-D20	MS-AB38-D20	MS-AB38-P10
<ul style="list-style-type: none"> • 20 Micron water detection & particulate removing filter 	<ul style="list-style-type: none"> • 20 Micron water detection & particulate removing filter 	<ul style="list-style-type: none"> • 10 Micron water detection & particulate removing filter
<ul style="list-style-type: none"> • Max Flow 94.6Lpm 	<ul style="list-style-type: none"> • Max Flow 94.6Lpm 	<ul style="list-style-type: none"> • Max Flow 94.6Lpm
<ul style="list-style-type: none"> • Max Pressure 3.4Bar 	<ul style="list-style-type: none"> • Max Pressure 3.4Bar 	<ul style="list-style-type: none"> • Max Pressure 3.4Bar
<ul style="list-style-type: none"> • Product Diesel 	<ul style="list-style-type: none"> • Product Diesel 	<ul style="list-style-type: none"> • Product Gasoline
<ul style="list-style-type: none"> • Max. Pressure: 3 Bar 	<ul style="list-style-type: none"> • Max. Pressure: 3 Bar 	<ul style="list-style-type: none"> • Max. Pressure: 3 Bar
MS-AB25-H-12UNF	MS-AB38-H-16UNF	
<ul style="list-style-type: none"> • Housing in aluminium to suit AB25 Cartridge 	<ul style="list-style-type: none"> • Housing in aluminium to suit AB38 cartridge 	

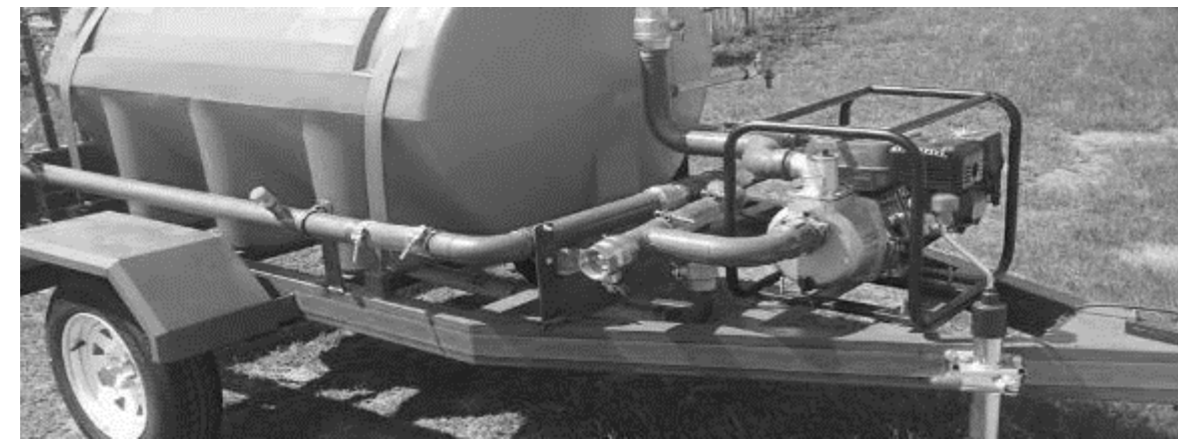

ProFlow



APG
INDUSTRIAL



Positive Displacement Meter

The Proflow positive displacement rotary volumetric flow meter provides a low pressure drop using three moving elements within the measuring chamber. The system provides accurate measurement for batching, blending, transfer and metrology use in the aviation, chemical, petroleum, agricultural, paint and textile industries.

***SABS Approved**

Description	PBM-40	PBM-50	PBM-80	PBM-100
Flow Rate (min)	25 l/min	50 l/min	75 l/min	130 l/min
(max)	250 l/min	500 l/min	750 l/min	1300 l/min
Inlet	40mm (1 1/2")	50mm (2")	80mm (3")	100mm (4")
Outlet	40mm (1 1/2")	50mm (2")	80mm (3")	100mm (4")
Accuracy %	+/-0.25%	+/-0.25%	0.25%	+/-0.25%
Pressure	10 Bar	10 Bar	10 Bar	10 Bar

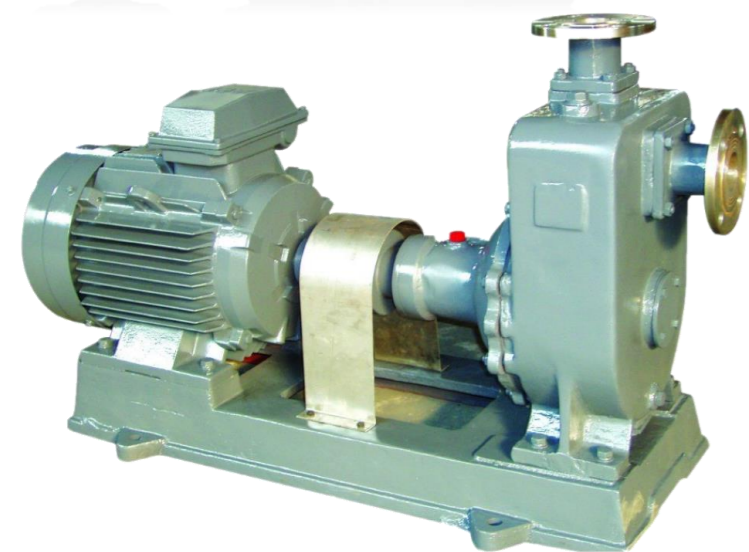

Self Priming Centrifugal Pump

The self priming pump supplied with EX Rated electric motor and coupling mounted on skid. This range has a strong self priming capacity and easy to maintain.

Flow range: 250 – 1100L/min.

Industry: Petrochemical



Rotary Vane Pumps

These pumps have a number of vanes that are free to slide into or out of slots in the pump rotor. When the pump driver turns the rotor, centrifugal force, rods, and/or pressurized fluid causes the vanes to move outward in their slots and bear against the inner bore of the pump casing forming pumping chambers. As the rotor revolves, fluid flows into the area between the vanes (pumping chambers) when they pass the suction port. This fluid is transported around the pump casing until the discharge port is reached. At this point the fluid is squeezed out into the discharge piping.



MannTek



APG
INDUSTRIAL 

MannTek

- MANNTEK specialise in connections
- Since 1997 they have developed, produced and manufactured innovative coupling products for some of the world's most demanding industries when it comes to safety. That means solutions beyond expectations – all the way.

MARKET SEGMENTS

- **Gas (LPG)**
- **Marine/Offshore**
- **LNG Solutions**
- **Aviation**
- **Petroleum**
- **Container**
- **Chemical Industry**
- **Rail Tankers**
- **LNG/Cryogenic**
- **Military**

PRODUCT APPLICATIONS

- **Couplings**
 - Dry Gas Couplings
 - Dry Aviation Couplings
 - Dry Cryogenic Couplings
- **Dry Evotek Couplings**
 - Dry Evotek Couplings
- **Breakaway Couplings**
 - Safety Breakaway Couplings
 - Cryogenic Breakaway Couplings
- **Swivel Joints**
 - Swivel Joints
- **Full Flow Ball Valves**
 - Full Flow Ball Valves
- **Innovative Accessories**
- **LNG Solutions**



Safety Breakaway Couplings



Full Flow Ball valves



Dry Evotek Couplings



Cryogenic Breakaway Couplings



Dry Cryogenic Couplings



Dry Aviation Couplings



Dry Disconnect Couplings



Dry Gas Couplings



Swivel Joints



LNG Solutions



Innovative Accessories





- Liquip is one of the leading Tanker and Terminal equipment brands in the world.
- Liquip is a leader in quality products and solutions for specialist fluid transfer applications.
- Liquip has built its reputation for excellence over 40 years supplying equipment for the bulk liquid handling and storage industry. In markets across the globe, Liquip is renowned for its comprehensive product range with exceptional whole of life value.
- Liquip has built solid partnerships in more than 30 countries worldwide. This distribution network brings local knowledge, expertise and dedicated service to the most remote of markets.





- LIQUIP is one of the leading Tanker and Terminal equipment brands in the world.
- LIQUIP is a leader in quality products and solutions for specialist fluid transfer applications.

MARKET SEGMENTS

- **Tanker**
- **Terminal**
- **Retail**
- **Aviation**
- **Dry Bulk**
- **Fuelling Solutions**
- **Fibrelite**
- **Skids**
- **Military**

PRODUCT APPLICATIONS

- **Road Tank Trucks.**
- **Aviation Refuelling.**
- **Petrochemical terminals and depots.**
- **Retail Fuel Sites.**
- **Fuel Filtration.**
- **Rail Cars.**
- **Storage Tanks.**
- **Dry Bulk Tankers**
- **Military Fuelling.**

Liquip Product Range



Tanker Top



Tanker Bottom



Tanker Accessories



Meters, Dispensing & Gauging



Tanker Overfill Systems



Loading Arms



Loading System Components



Overfill Protection



Meters, Dispensing & Gauging



Vapour Recovery



Interconnect



Above Ground



Below Ground



Automatic Tank Gauging

Liquip Product Range



Bottom Loading



Aviation Filtration



Aviation Overflow



Hydrant Pit Valves



**Hose Reels ,
Nozzles & Fittings**



**Meters, Pumps &
Displays**



**Valves &
Accessories**



Aeration Systems



Butterfly Valves



Hopper Tees



Swing Check Valve



LM Manholes



Pipe Couplers



Relief Valves



Air Operated Actuators



Filtration



Strainers



**Quick Flush Tanks,
Dewatering**



Floating Suctions



Retail Fuelling



Manhole Covers



Trench Covers



Underground Enclosures

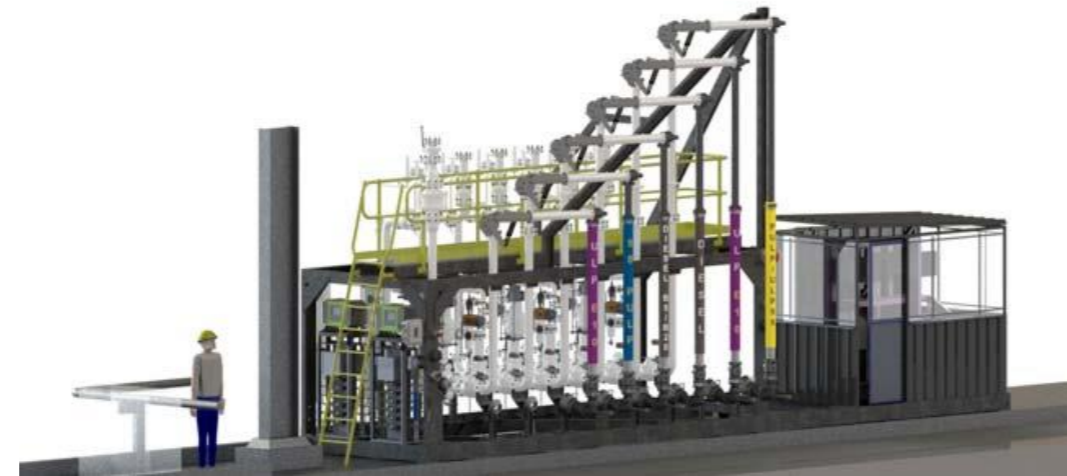

SKID Solutions



Military Fuelling Solutions



KALYMNOS

APG
INDUSTRIAL



KALYMNOS

- Kalymnos is a leading brand in the delivery of Tanker Fuel Delivery and Fuel Engineering solutions.
- Kalymnos produces a wide range of liquid fuel transport equipment, manhole cover, complying to the demands of the ADR regulations and offers unrivalled safety and operational features.
- Innovative design, ease of maintenance, and durability are the key benefits of Kalymnos products, covering a wide range of profiles and functionalities, which provide complete solutions for every fuel tanker application.





KALYMNOS

Man Hole Covers

- ADR Covers
- Other Covers
- Weld Neckings
- PV Vents
- Dipsticks



KALYMNOS

Bottom Valves

- 3" Valves
- 4" Valves
- Sumps & Flanges
- Operators



KALYMNOS

Vapour Recovery

- Vapour Transfer Valves
- Coaming Vent Valves
- Vapour Recovery Adaptors
- Vapour Recovery Couplers



KALYMNOS

API Adaptors

- Bottom Loading Adaptors
- Caps
- Gravity Discharge Couplers



KALYMNOS

Pneumatic Control

- Control Panels
- Air Accessories



KALYMNOS

Overfill Prevention

- Optic Sensors
- Optic Sockets
- Intellicheck
- Accessories



KALYMNOS

Delivery Equipment

- Fittings
- Hose Assemblies
- Service Station
- Health & Safety





sillea

APG
INDUSTRIAL



- Silea has over 50 years been helping companies to solve the problem of liquid transfer (hydrocarbons, industrial liquids, chemicals and food).
- Silea designs and produces standard and customizable products for your every need.
- This is the goal of Sileas daily commitment.



silea

**Floating Suction
for Tanks**



1501 SERIES
Floating suction

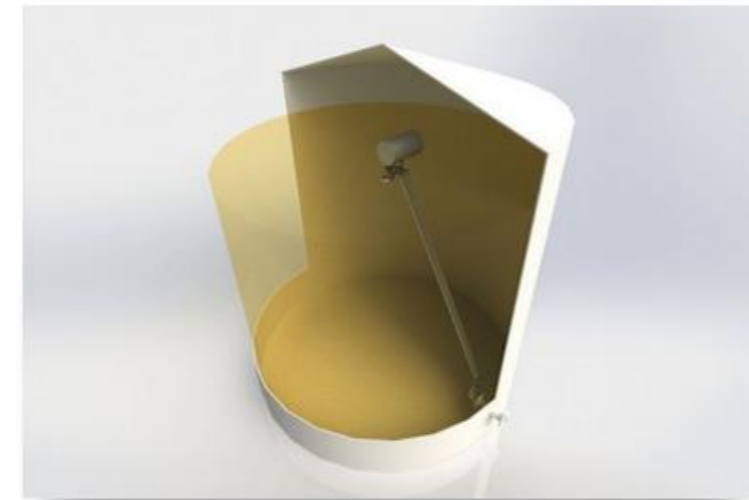

1502 SERIES
Floating suction

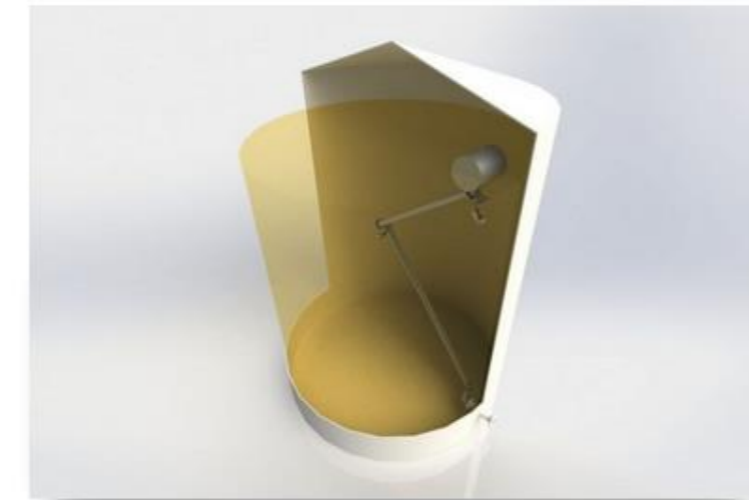

1505 SERIES
Floating suction

silea

**Positive
Displacement
Rotary Vane Pumps**



1052E SERIES
Pump



1056 SERIES
Pump unit

silea

Top Loading Arms



1050 SERIES
Top loading arm



1101 SERIES
Top loading arm



1201 SERIE
Top loading arm



1201 VR SERIES
Top loading arm + Vapour Recovery

silea

Bottom Loading Arms

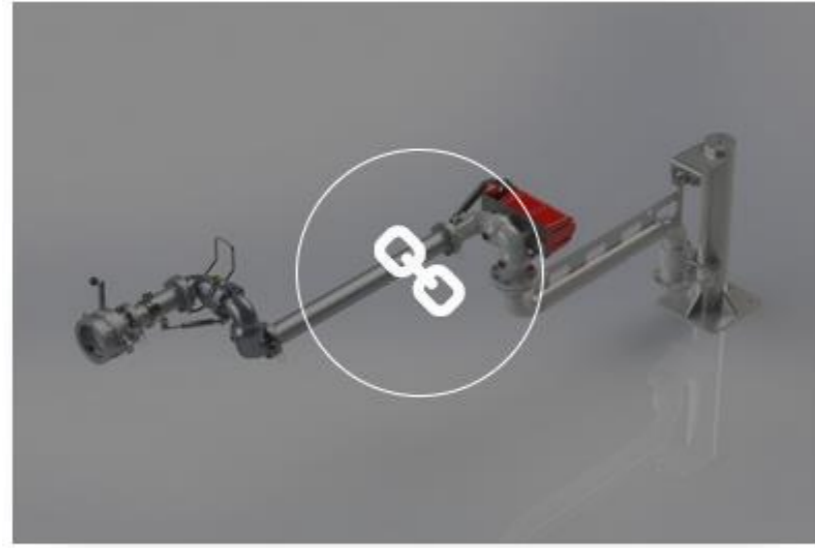

1403 SERIES



1405 SERIES



1701 SERIES

silea

LPG Loading Stations

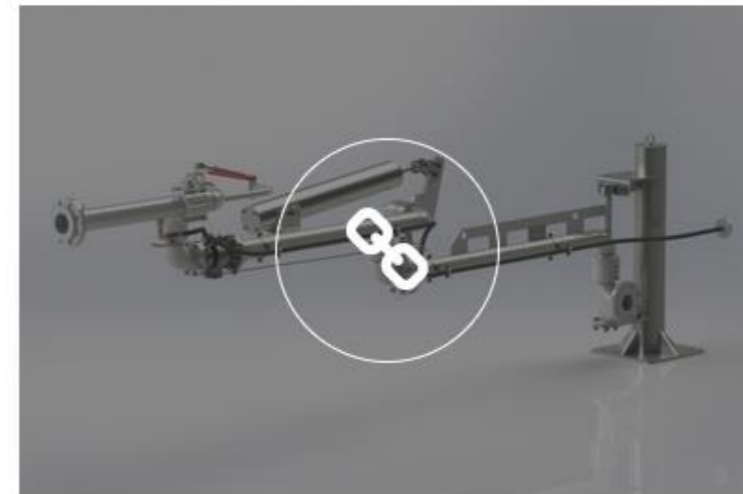

1802 SERIES

Loading arm for LPG



1803 SERIES

LPG loading station

silea

**Folding Stairs
Metering Skid
Components**







- One of the Leading Manufacturers of Overfill Prevention & Grounding Systems.
- Established in 1996, Alptec Safety Equipment specializes in the design, manufacture, and supply of high-quality products for the chemical, petrochemical, oil and gas and process industries that transport, store, transfer and use solvents or combustible liquids in hazardous areas.
- Overfill Protection
- Static Grounding Systems
- Earthing Clamps
- Reels and accessories.



Overfill Protection & Grounding Systems



Portable Digital Density Meter



Static Grounding Devices



Retractable Grounding Reels



Static Grounding Monitoring Systems



Personal Electrostatic Eliminating Arms



Leakage Detectors



Radar Motion Detectors



McCabe

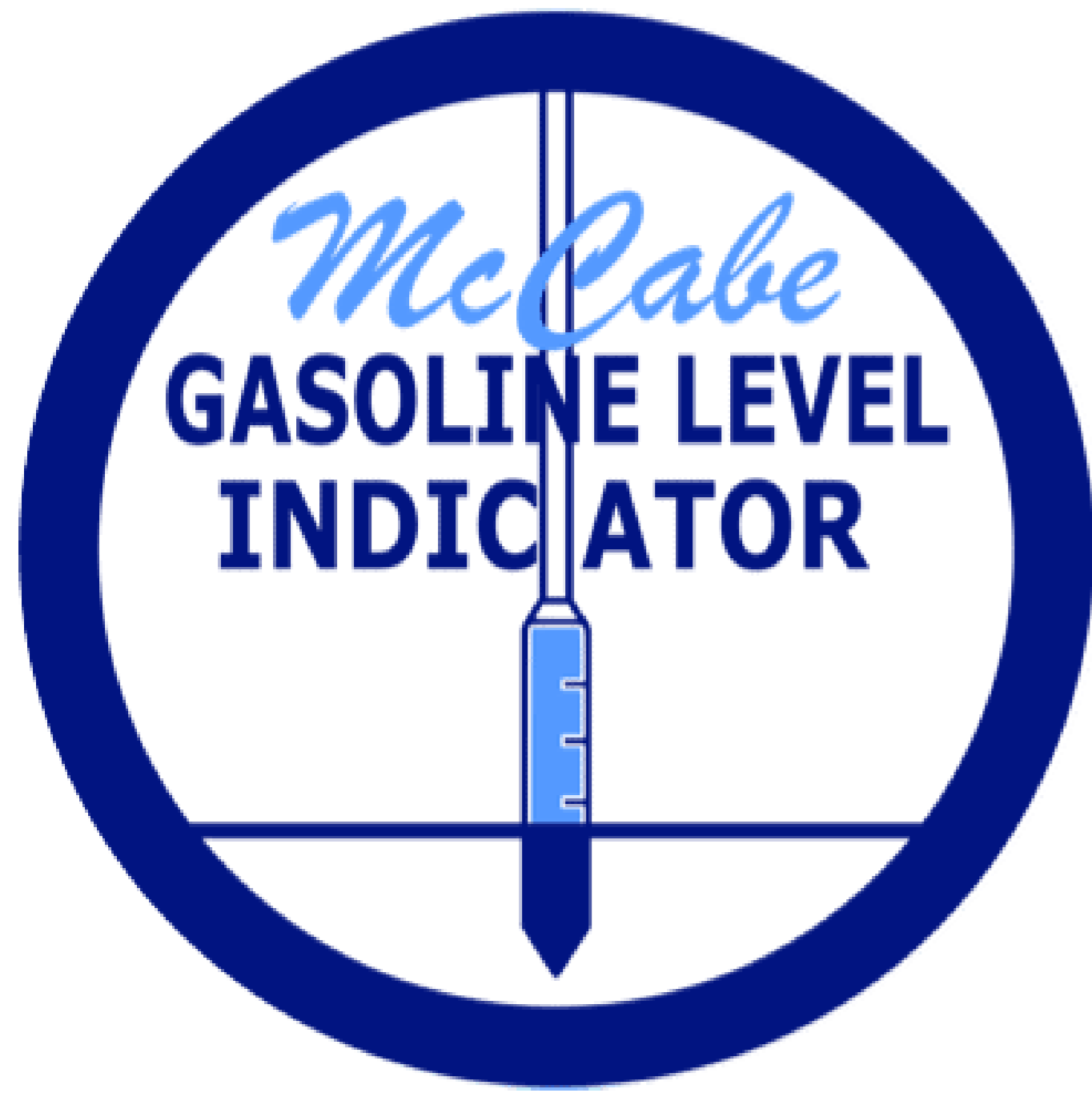

McCabe
H₂O PLUS+
WATER LEVEL
INDICATOR

McCabe

- Family owned and operated business since 1930
 - **Water Level Indicator paste**
 - The H2O Plus+ Water Level Indicator Paste is a dark green paste that turns dark red when it comes into contact with water. The H2O Plus+ Water Level Indicator Paste is used to detect free water in almost all petroleum products as well as some petrochemicals, chemicals and plant oils.
 - **Fuel level Indicator paste**
 - The gasoline paste is a light sky blue paste that turns a darker blue when immersed in gasoline, diesel, kerosene, naphtha, #2 heating oil, light crude oil, jet fuel and others.



McCabe

McCabe & Sons, Inc.

Use

The H2O Plus+ Water Level Indicator Paste is a dark green paste that turns dark red when it comes into contact with water. The H2O Plus+ Water Level Indicator Paste is used to detect free water in almost all petroleum products as well as some petrochemicals, chemicals and plant oils.



Application

Spread a smooth, even coat of the product on the bob or gauging device where you anticipate free water to be present. Lower the gauging device through the product to the bottom of the tank and leave it for approximately ten seconds or more. Heavier products may require a longer immersion time. If there is water present, the green paste will turn dark red contrasting to the green color above the water level.



Gauging Ethanol Fuels

McCabe H2O Plus+ Water Level Indicator Paste can also be used to determine the presence of water and water/alcohol bottoms in ethanol gasoline. There are gradient color changes as one moves through the spectrum of possible water/alcohol concentrations. The normal dark red color change seen when gauging just water bottoms is also seen in water/alcohol bottoms where the bottoms range from 0% to 35% alcohol. Thereafter, the dark red color change lightens to a fuchsia/light purple change in a 50% water/50% alcohol bottom. When the water/alcohol bottom reaches approximately 75% alcohol, the color change is an off white up to 99% or more alcohol (mainly an alcohol bottom).

Readings in E-10

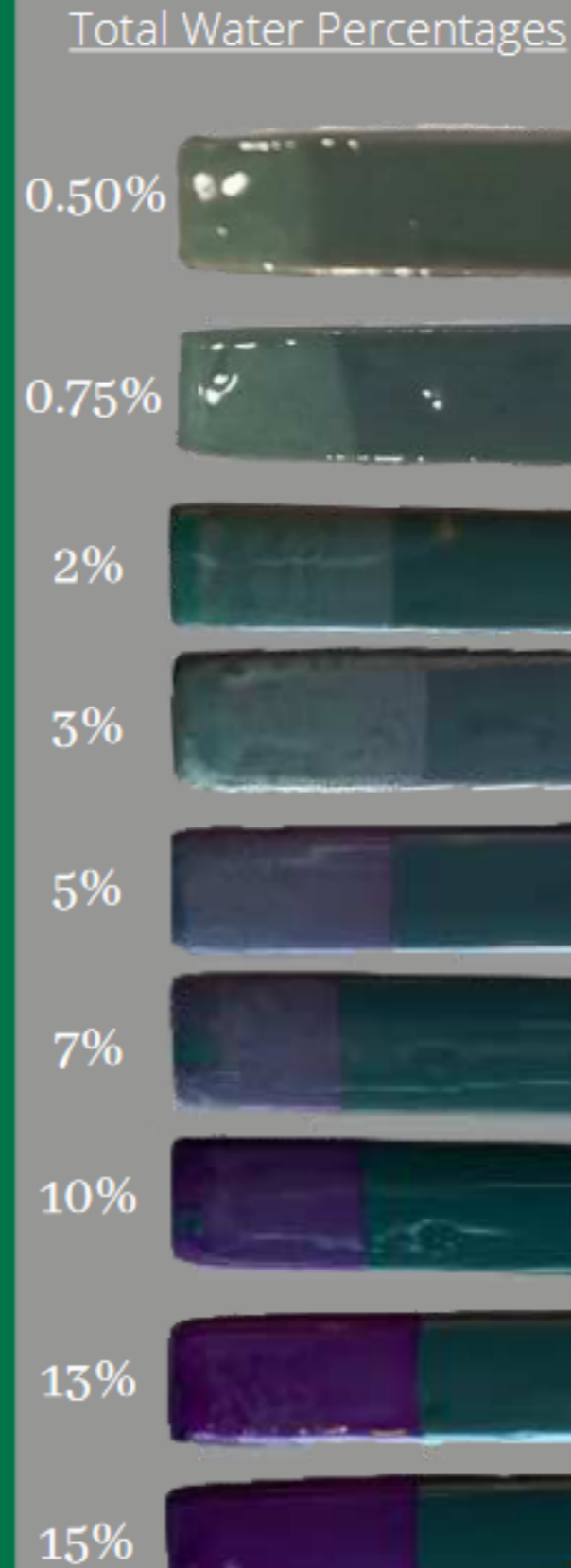

McCabe & Sons, Inc.

Family Owned and Operated since 1938

Use

The gasoline paste is a light sky blue paste that turns a darker blue when immersed in gasoline, diesel, kerosene, naphtha, #2 heating oil, light crude oil, jet fuel and others.



Application

Spread a smooth, even coat of the product on the bob or gauging device where you expect the air/product interface to be located. Once entering the product, leave immersed for approximately ten seconds and the paste will turn a darker blue. When reading the results, note a straight, sharp demarcation on the gauging device, light blue above/dark blue below.

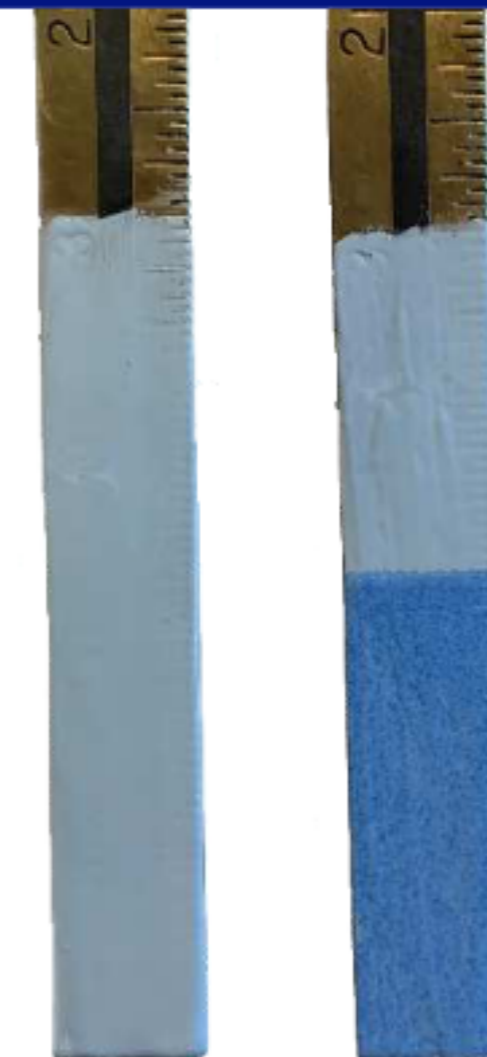

Part #MC200

Pneumatics & Automation Parts

PneumatiX

ACL

TPUCO

PNEUMAX

ISAIAH

Weforma
Dämpfungstechnik GmbH

AIRBEST

JOC

LANBAO

nircomp
Automation

Our Brands



PNEUMAX

PneumatiX

TPUCO®

ACL

ISAIAH



Weforma

Dämpfungstechnik GmbH

LANBAO

nircomp

Automation

AIRBEST

Our Markets

- Automotive Industry
- Electronics industry
- Food and Beverage Manufacturing
- Processing Plants
- Machine Tools
- Woodworking
- Textile Industry
- Agricultural
- Electric Automation
- Mining
- Machinery & Safety
- Transport

Our Products

- Cylinders
- Valves
- Actuators
- Pneumatic Fittings
- Sensors
- Air Service Units
- Vacuum Technology
- Vibration Control
- Manipulation Units
- Tubing

PneumatiX

PneumatiX is a homegrown South African brand in the Pneumatics Industry, consisting of a wide range of pneumatic solutions. Sourced from quality global manufacturers, PneumatiX provides the industry with a wide choice of products and competitive prices.

- Pneumatic Fittings
- Pneumatic Tubing
- Cylinders
- Air Service Units
- Vacuum Technology
- Magnetic Sensors
- Process Valves
- Pneumatic Valves
- Solenoid Valves
- Electric Actuation

PNEUMAX

Pneumax products are the outcome of a focused and simultaneously far-sighted business vision which strives to apply flows and processes characterized by efficiency. Custom products are complemented by a varied catalogue of technological solutions capable of making the difference in every sector of the industry.

ACL

ACL's valves are employed in a large variety of market sectors and sub-sectors. Examples water treatment, electrical appliances, industrial process, heating and air-conditioning, medical equipment, automotive, textile, food, pneumatic and many others.

TPUCO

Taiwan PU Corporation is a professional maker of Polyurethane Materials and Finished Products. TPUCO manufactures various kinds of polyurethane products according to any client's special requirement.

- Polyurethane Air Hoses
- Polyurethane Spiral Tube
- Polyurethane Pneumatic Tube
- High Pressure Hose
- PTFE Tube
- Nylon Tube
- PU Tube
- Silicone Tube

ISAIAH

ISAIAH manufactures a comprehensive range of pneumatic fittings, pneumatic components, pneumatic control components, pneumatic actuators, that are designed and engineered to the highest standards.

- Pneumatic Fittings
- Valves
- Pneumatic Air Cylinders
- Air Combination Units
- Accessories

LANBAO

Lanbao are leaders in intelligent inductive sensors, photoelectric sensors and capacitive sensors.

Weforma Dämpfungstechnik GmbH

Weforma specialises in hydraulic industrial shock absorbers, heavy duty shock absorbers, elevator shock absorbers, deceleration cylinders, speed controls, rotary dampers, pallet stoppers and gas springs.

In the area of vibration isolation, we offer a wide range of air springs, PUR buffers and metal cushions.

AIRBEST

AIRBEST is a manufacturing and service enterprise, which is engaged in the R&D, production, and sales of vacuum grabbing products (vacuum generators, vacuum suction cups, vacuum grippers, etc.). It provides various vacuum grabbing solutions according to customers' needs. Its products are involved in multiple industries including intelligent manufacturing, automobile sheet metal stamping, packaging, communication electronics, lithium battery, photovoltaic, wood, stone, robot, food, and medical industry, etc.



JOC Machinery Co., Ltd. Was founded in year 2000, specializing in foreign trade of machinery parts and complete sets of equipment. The ranges of products and services covering construction and building machinery, petroleum machinery, mining equipment, power cable production lines, electric power fittings, vehicle and motorcycle parts, industrial valves and etc.



During the 70s, when the soul of the pneumatic industry was still carved in metal, Aircomp conceived a product range consisting of pneumatic components made of thermoplastic technopolymers. This was a bold choice, that only a strongly innovative mind could pursue. Today, after half century of activity, we are the Italian company having the greatest experience in the sector of technopolymers applied to the pneumatic automation, while the spirit of innovation remains the corner stone of our identity.

Automotive



Workshops
Dealerships
Wholesalers
OE
Manufacturers

Tanker & Terminal



Tanker
Fuel Terminals
Bulk Terminals

Transport



Automotive
Railway
Aviation
Airports
Marine

OEM



Original
Equipment
Manufacturers

Fuel Distributors



Fuel and Diesel
Distribution

Mining & Construction



Civils
Mines
Mining Supply
Houses
Mining
Contractors

Agriculture



Co-Ops
Commercial
Farmers
Broad
Agricultural
Sector

Military



Military

Industrial



Mechanical
Chemical
Tanning
Wood
Marble
Manufacturing
Industry

Pneumatic Parts Range

APG Industrial offers a full range of Pneumatic and Automation parts, systems and components.



Cylinders



Actuators



Fittings



Air Service



Vibration Technology



Valves



Pneumatic Sensors



Adaptors



Silencers



Accessories

Fittings & Adaptors



Adaptors

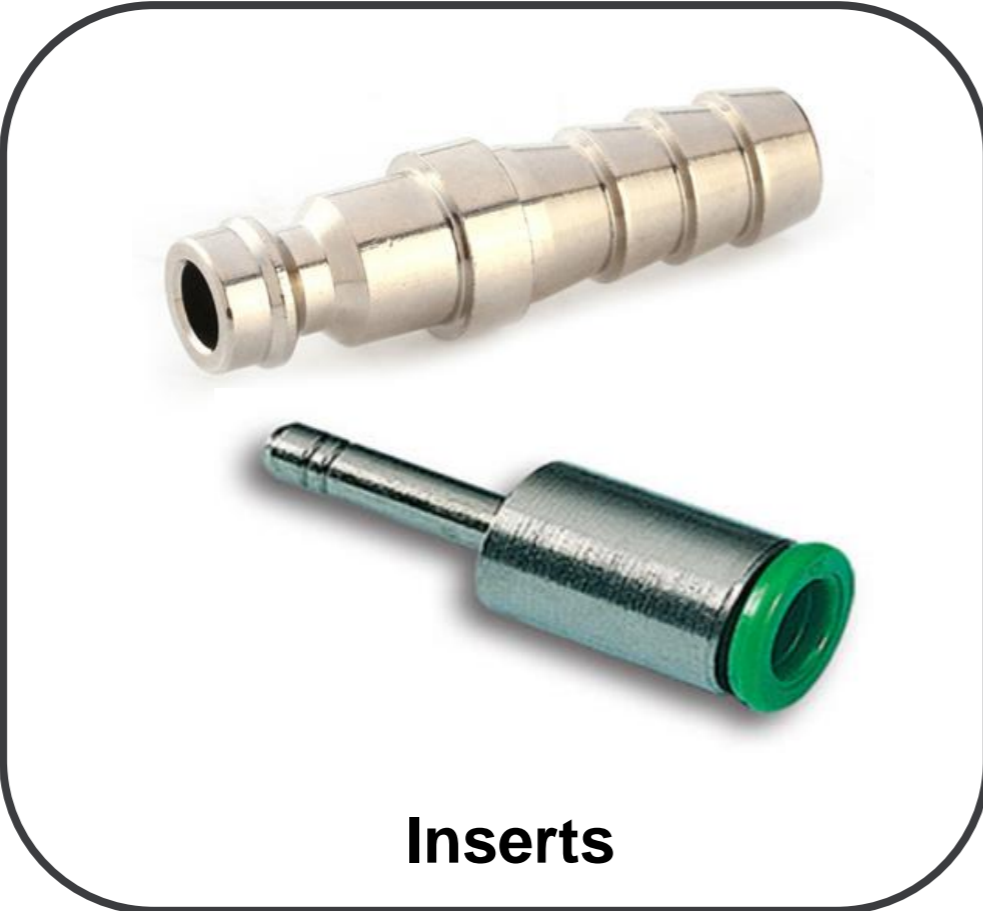

Inserts



Compression Fittings



Flow Control Fittings



Metal Fittings



Plastic Push In Fittings



Quick Control Fittings



Stainless Steel Fittings



Standard Fittings



Silencers

Poly Tubing



- High flexibility
- Small bending radius
- High tensile strength
- Available in ether and ester PU hoses
- Optimum abrasion resistance
- Low temperature flexibility

Teflon Tubing



- Low coefficient of friction
- Excellent non-sticky surface
- Good in chemical and weather resistance
- Excellent dielectric insulation properties
- Almost no aging

Nylon Tubing



- Excellent in weather resistance
- Resists abrasion and vibration
- Good aging
- Can withstand contact with chemicals, alkalis, dilute acids or oxidizing agents

Blue, Red, Yellow, Silver, Green, White, Black

Cylinders & Actuators



Compact Cylinders



Cylinder Material



Micro Cylinders



Rodless Cylinders



Positioners & Guides



Profile Cylinders



Slide Unit Cylinders



Imperial Mine Cylinders

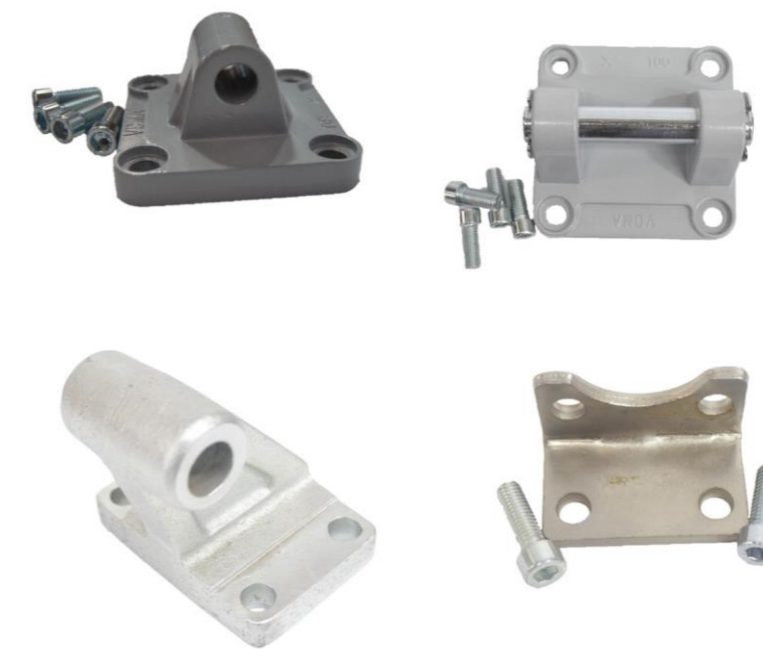

Mounting & Brackets



Accessories

Mechanical Valves



Complementary Valves



ISO Valves



Solenoid Valves

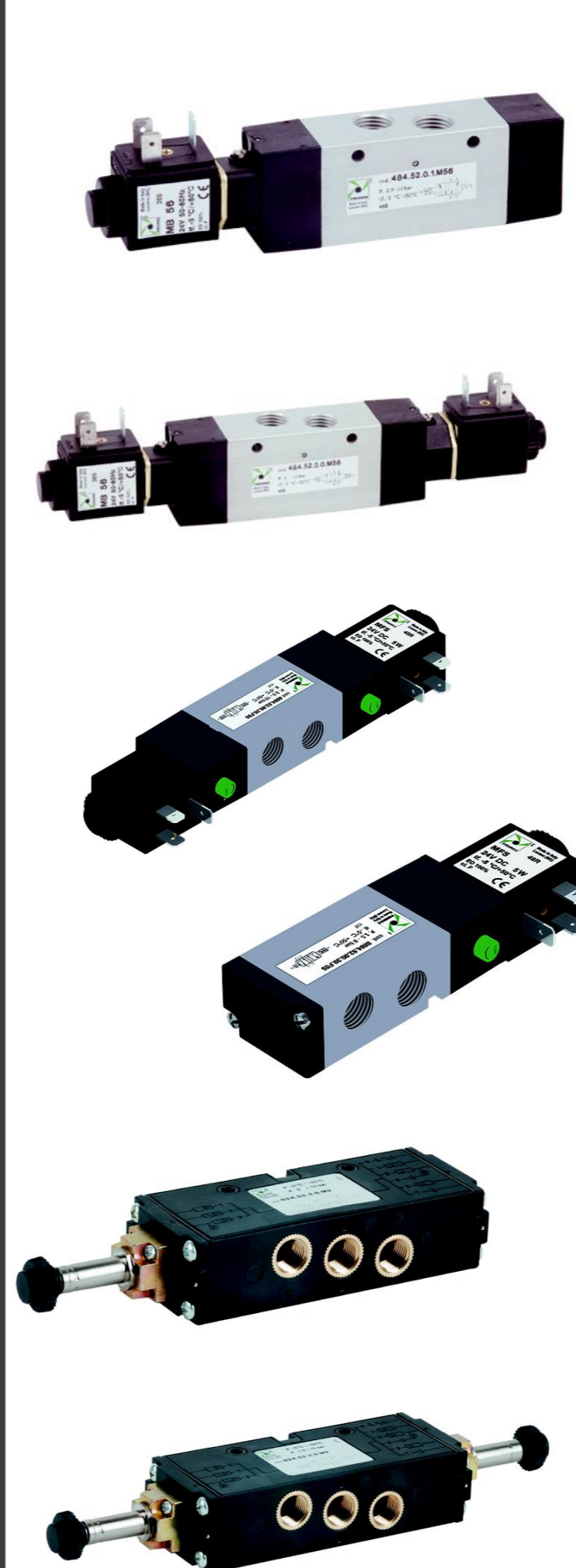

Optyma & Enova Valves

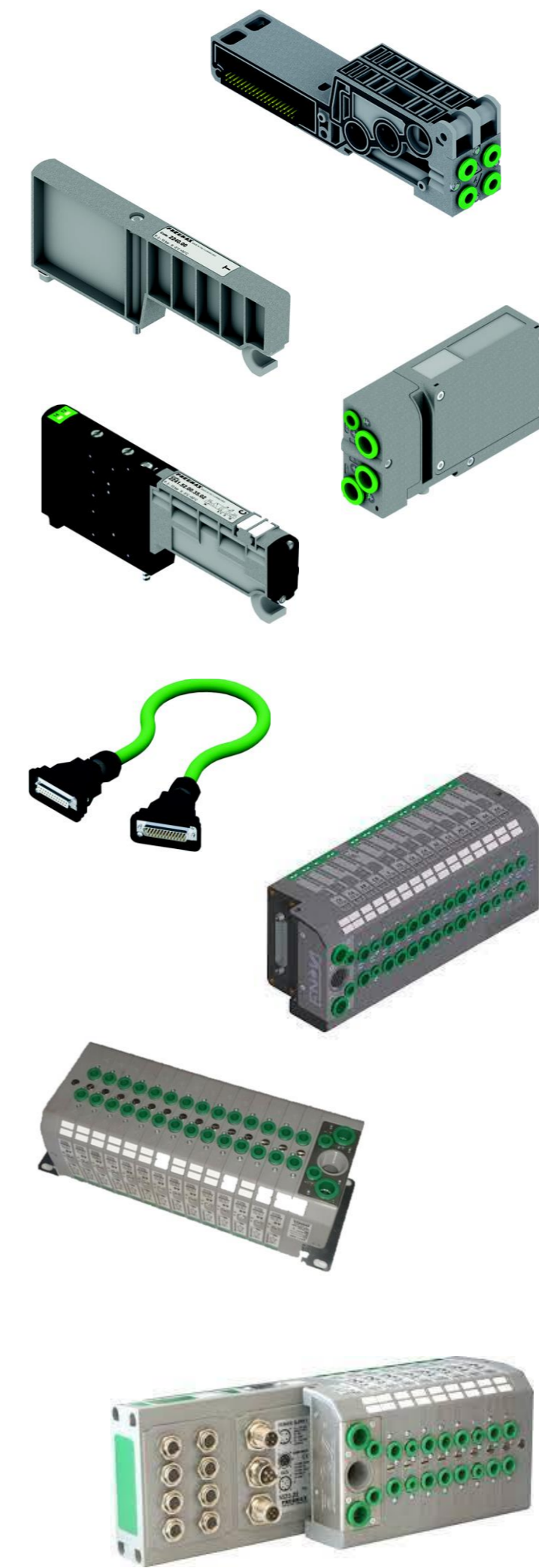

Pilot Valves





Air Service Units



Regulators



Filters



Lubricators

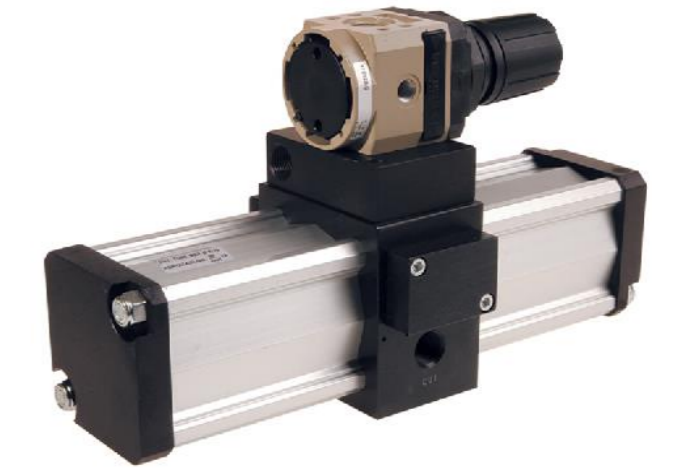

Pressure Boosters



Pressure Gauges



Lubricating Oil



Mountings



Brackets



Accessories



Product Range includes the following:-

1. Foot Valves
2. Hand Slide Valves
3. Hand Valves
4. Mechanical Valves 1"
5. Mechanical Valves 1/2"
6. Mechanical Valves 1/4"
7. Mechanical Valves 1/8"
8. Mechanical Valves 4MM
9. Mechanical Valves M5
10. Rotary Valves



To Increase the range of ISO 5599/1 Solenoid valves, we have added the new ISO-M12 series. These are available in three sizes, size 1, size 2 and size 3 with flow rates from 900 NI/min for size 1 up to the 3600 NI/min for size 3. The standard features of the ISO valves are still included, however, they are now combined with a M12 electrical connector located in the middle of the valve to manage the electrical signals. Versions are available to suit valves with both single and double 24VDC solenoids complete with IP65 protection, in addition all version are supplied with LED indicators.



Product Range includes the following:-

1. Shuttle Valves
2. Angle Seat Valves
3. Angle Seat Valve Seal Kits
4. Ball Valves
5. Blocking Valves
6. Butterfly Valves
7. Drain Valves
8. Flow Control Valves
9. Impulse Generators
10. Non-Return Valves
11. Not Gate Valves
12. Oscillator Valves
13. Pneumatic Timer Valves
14. Pressure Indicators
15. Pressure Switches
16. Progressive Start Up Valves
17. Quick Exhaust Valves
18. Shut Off Valves
19. Techno Fun Valves Fittings
20. Two Hand Safety Valves



484 SERIES

- High Flow rate
- More Cycles
- Only Pneumax coils fit.



8884 SERIES

- High Flow rate
- Interchangeable with other valves



824 SERIES

- The Rolls Royce of valves
- Extreme high flow rates up to 1350L/min.
- Very Durable and Robust

- All Pneumax Valves come standard without coils.
- All Valves are Multi Voltage

ACL Solenoid Process Valves

- ACL offers a wide range of solenoid valves in brass, stainless steel and plastic materials suitable for the interception of air, water, steam and all fluids compatible with these materials.
- The solenoid valves are 2 or 3-way, normally closed, normally open, for general service, with direct control or servo-operated, with connections from M5 to G3 “, with working pressures from vacuum up to 100bar. To be able to satisfy our customers, we pay attention to every request; our sales office is at your disposal for any information.



Optyma 32-S Solenoid Valves



- One size valve 12.5mm thick.
- Mono & Bi-stable valves and bases.
- Subbase assembled with tie-rod.
- IP65 Protection.
- Quick release valves – no need to strip complete valve bank.
- Quick coupling connections to base 4,6 and 8mm available.
- Voltage 24VDC PNP and NPN



Technical Innovation, Rational Design, High Performance and Extreme Compact Size

The Enova series has been developed according to the latest market requirements. Each valve comprises all the necessary pneumatic and electrical functions needed to produce a solenoid valve assembly. There are no limits to the configurations of the solenoid valve island.

- Clean Profile.
- Compact Size: Modules of 12,5 mm.
- 4,6 and 8mm Connections.
- IP65 Grade
- Optimized electrical connection system.
- Electrical and Pneumatic connections on one side
- Quick coupling Connection with visual indicator



Product Range includes the following:-

1. Pilot Valves 1/2"
2. Pilot Valves 1/4"
3. Pilot Valves 1/8"
4. Pilot Valves ISO
5. Pilot Valves M5
6. Pilot Valves Poppets



- A pilot valve is a small valve that controls a limited-flow control feed to a separate piloted valve.
- Typically, this separate valve controls a high pressure or high flow feed.
- Pilot valves are useful because they allow a small and easily operated feed to control a much higher pressure or higher flow feed, which would otherwise require a much larger force to operate; indeed, this is even useful when a solenoid is used to operate the valve.

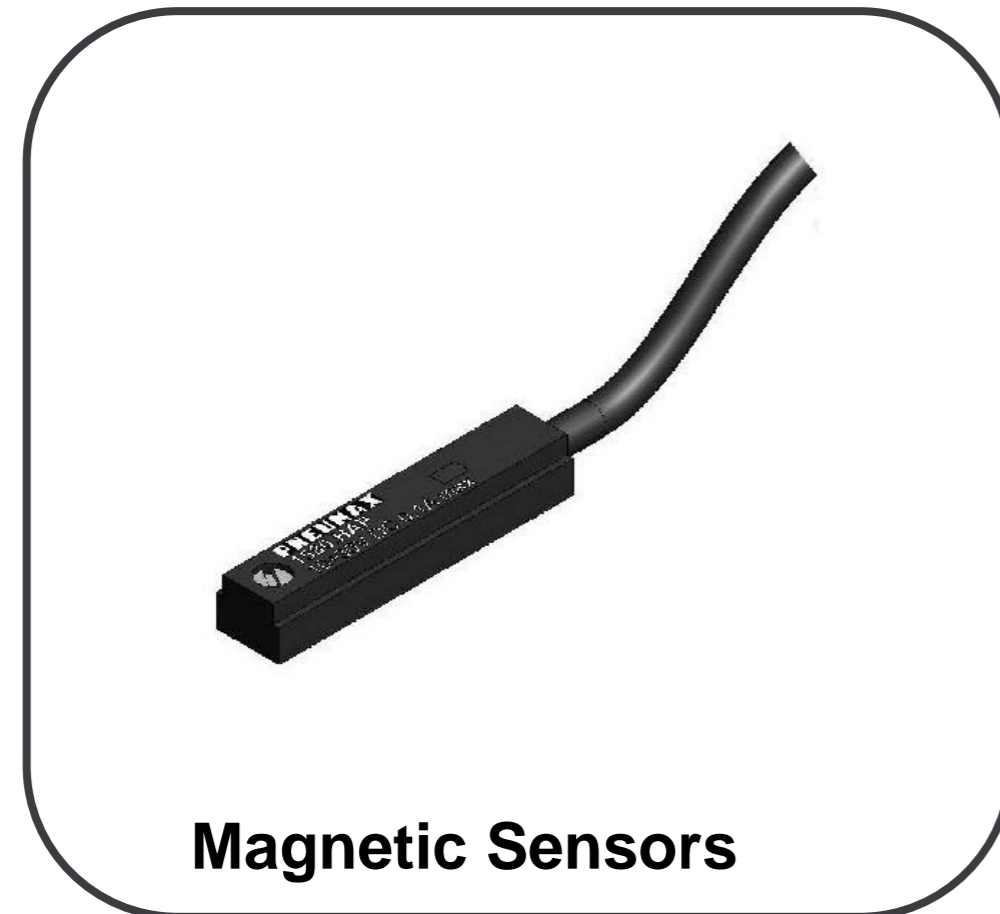

Magnetic Sensors



Cable

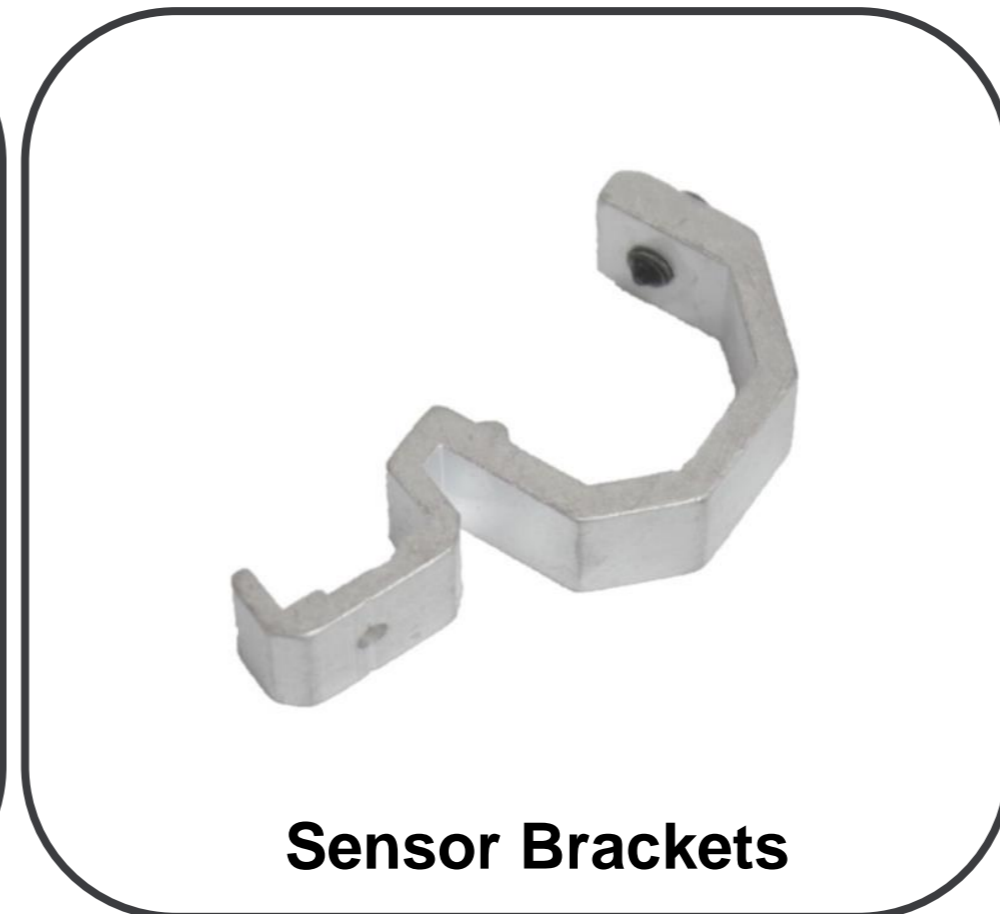

Sensor Brackets

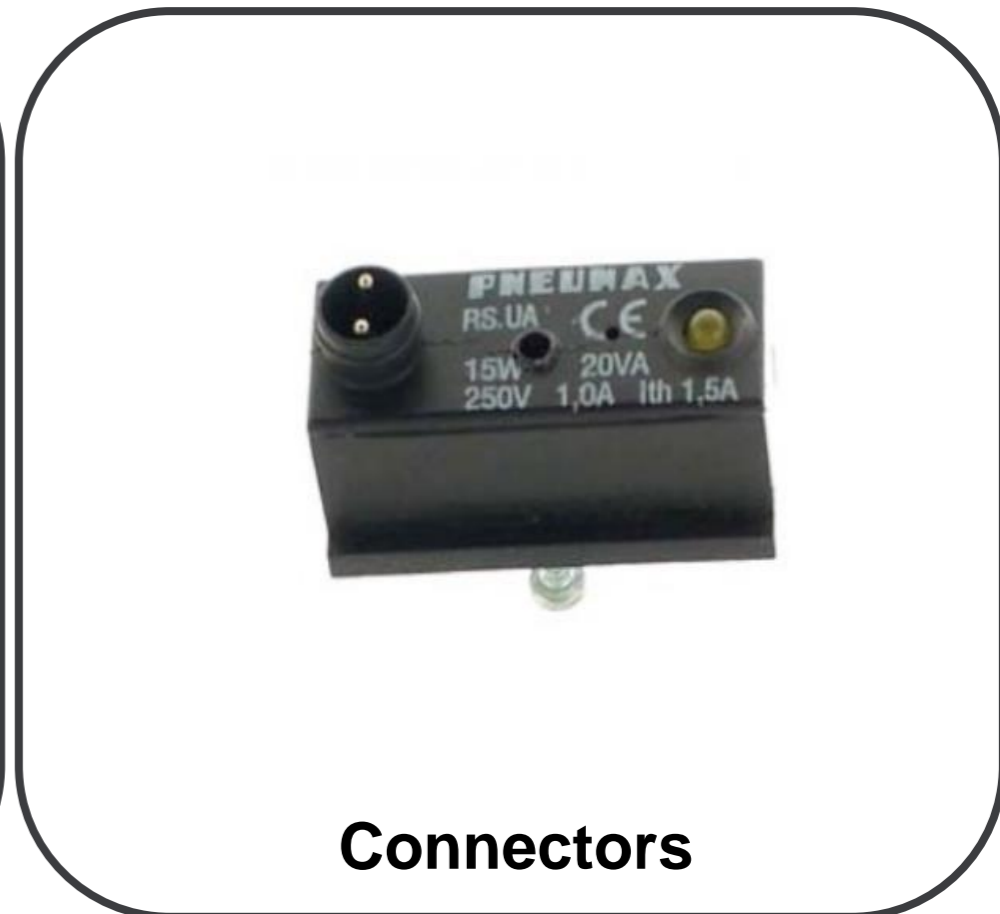

Connectors

The limit switches, or magnetic sensors, have to be mounted on cylinders with magnetic piston.

These, when hit by the magnetic field generated by the piston as it approaches, close the circuit sending an electrical signal by relè solenoid valve control, etc. or converse with the controlling electronic system situated on the machine.

There are available magnetic sensor with ampulla Reed type and with Hall effect. The sensors are attached to the cylinder by a proper clamp, slot or adaptor and have an activation LED indicator.

Vibration & Deceleration Technology



Industrial Shocks



Rotary Dampers



Deceleration Cylinders



Vibration Technology



Vacuum Ejectors



Vacuum Filters



Vacuum Pads & Cups



Vacuum Pumps



Vacuum Switches

Some examples of Vacuum technology in action

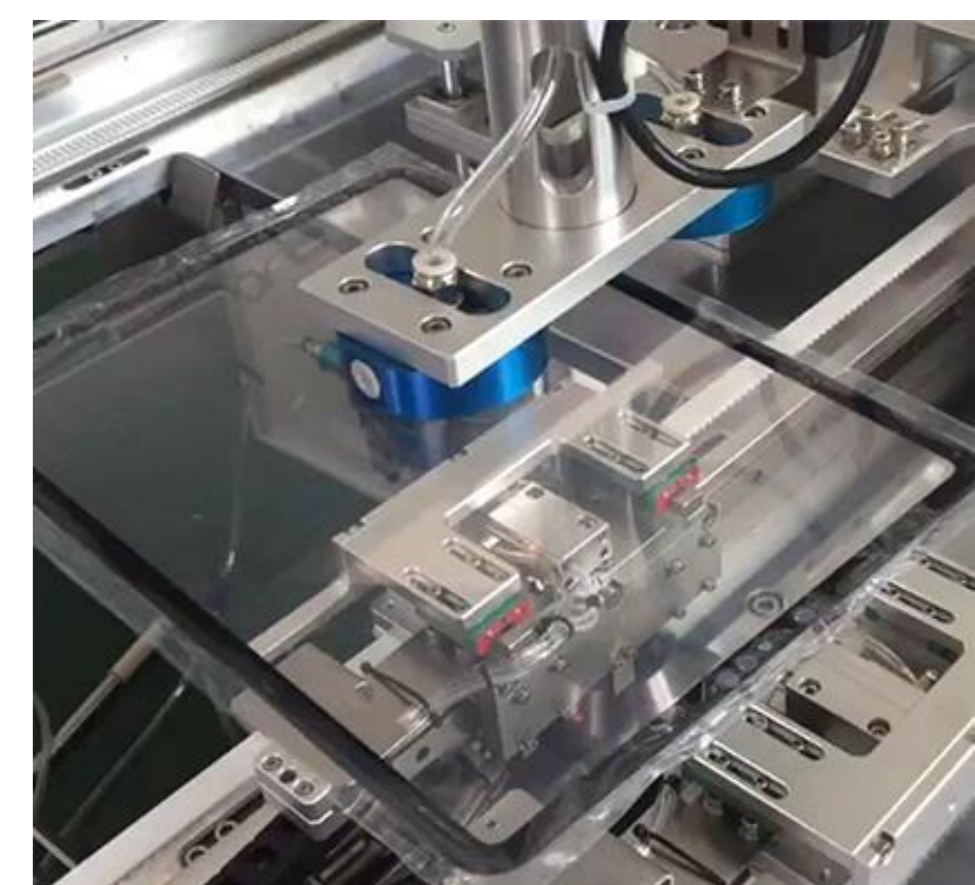
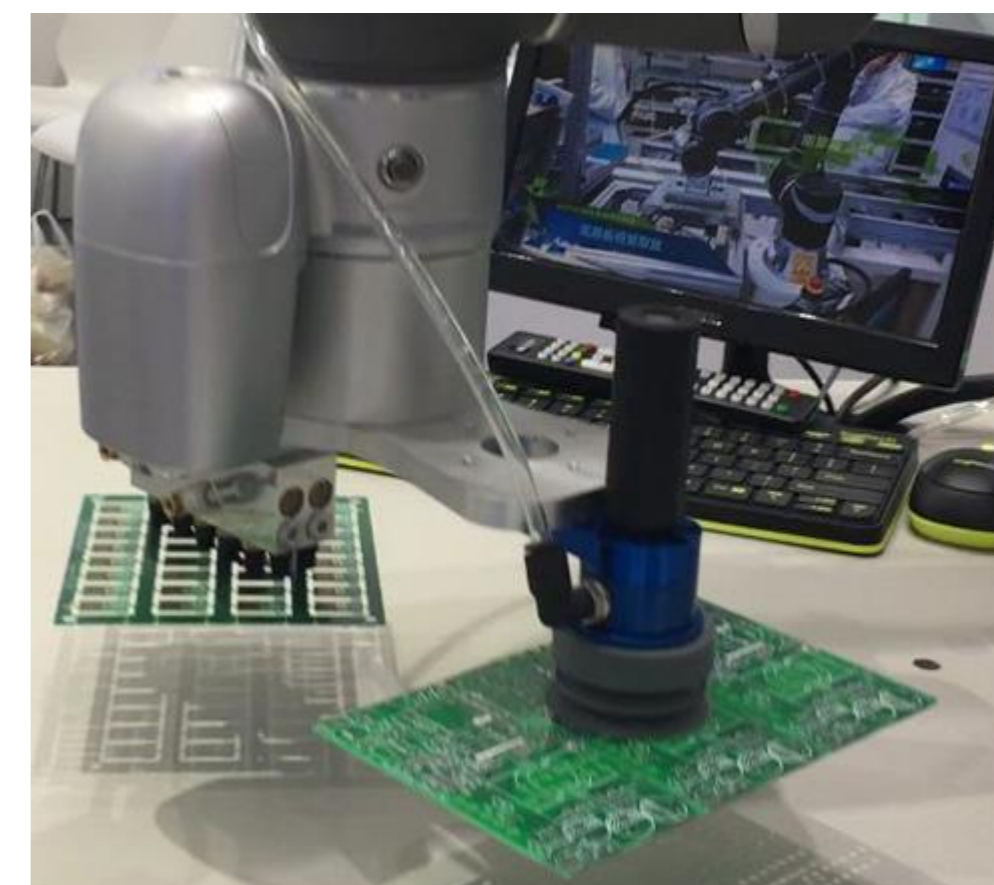

Cylinders

Actuators

Fittings

Air Service

Vibration Technology

Valves

Pneumatic Sensors

Adaptors

Silencers

Accessories

Rotary Actuation

Pneumatic actuators are used for pneumatic butterfly valves and pneumatic ball valves, directly installed ideal for the oil industry and water industry.

The Piston type actuator body is aluminium alloy, surface hard anodized.
ISO5211 pneumatic actuators come in double acting and single acting types.





Mining Products



Imperial Mine Cylinders



IMPERIAL MINE CYLINDER

DIMENSIONAL SPECIFICATION

Bores	04"	05"	06"	08"	10"	12"
Stroke	325	331	337	343	349	355
A	35	47.4	47.4	57.3	79.3	76.2
AA	85.9	95	104.6	146.3	169.4	166.1
AD	75.7	75	74.8	49	107.4	110.3

Pneumax Imperial Mine Cylinders are locally manufactured & can therefore be supplied in various configurations including any stroke length, with different steel mountings. Specials are also made to customer requirements and applications.

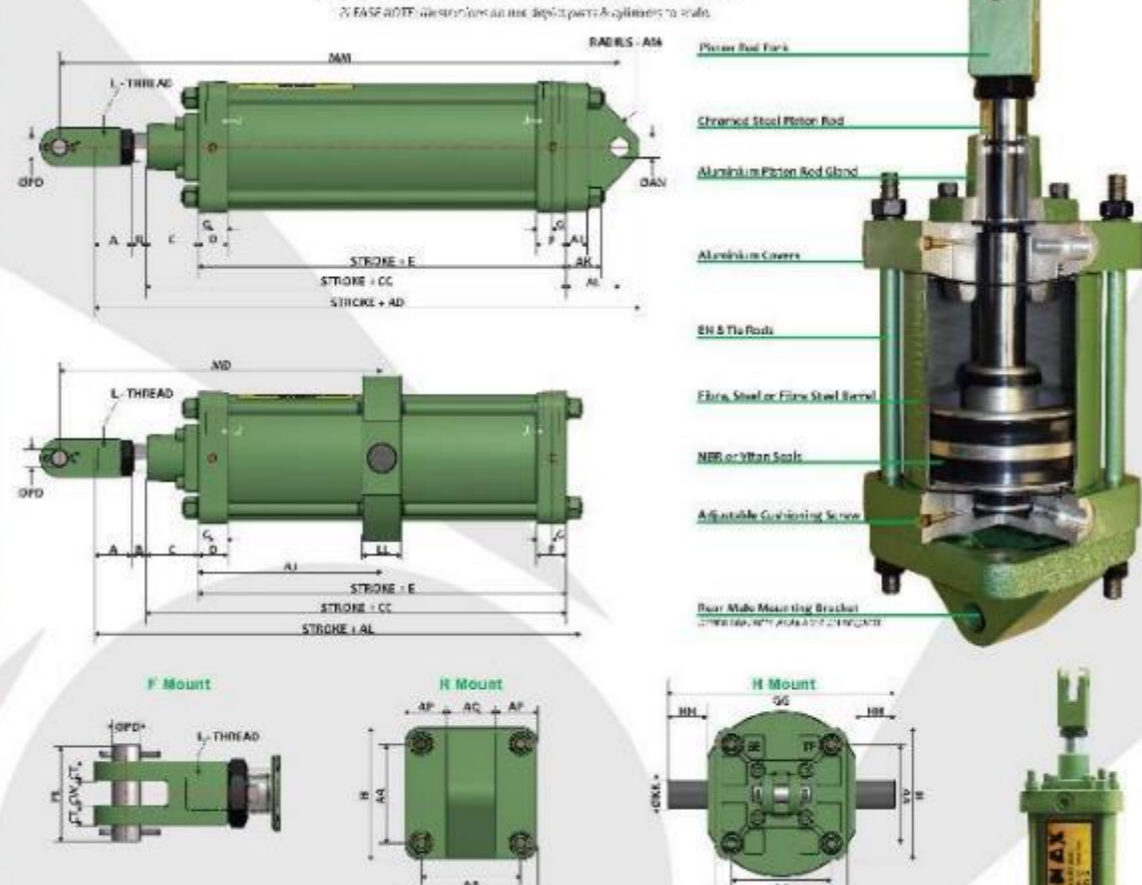

CONSTRUCTION OF ORDERING CODES

IC	04", 05", 06", 08", 10", 12"	FB	F	H	S
Imperial Mine Cylinder	Cylinder Diameter in inches	Bores Material	Cylinder Mounting	Cylinder Mounting	Stroke Length

LIGHT DUTY SEAL KITS AVAILABLE

ITEM	04"	05"	06"	08"	10"	12"	DESCRIPTION
1	1010100	1010100	1010100	1010100	1010100	1010100	SEAL KIT FOR 04" TO 12" BORES

TECHNICAL SPECS

- Fluid: Mineral Lubricated Air
- Operating pressure: 210 bar
- Conditioning: adjustable to 50°C
- Operating temperature: -40°C to +80°C
- Protect Rod: Chromi-nickel-plated rod
- Barrel options: 1 Drw, 1 Drw Steel or Steel barrel
- Flange: 100 & 150
- Covers: Piston & Glend Aluminium alloy castings

SPARE PARTS LIST

ITEM	04"	05"	06"	08"	10"	12"	DESCRIPTION
1	1010100	1010100	1010100	1010100	1010100	1010100	SEAL KIT FOR 04" TO 12" BORES



- All Cylinders are built to the specification of the customer.
- Brackets can also be specified.
- Stroke: Any stroke on all cylinders
- Dia: 6", 8", 10", 12"



Rail Switch Devices

Used to change the direction of Railway lines underground.

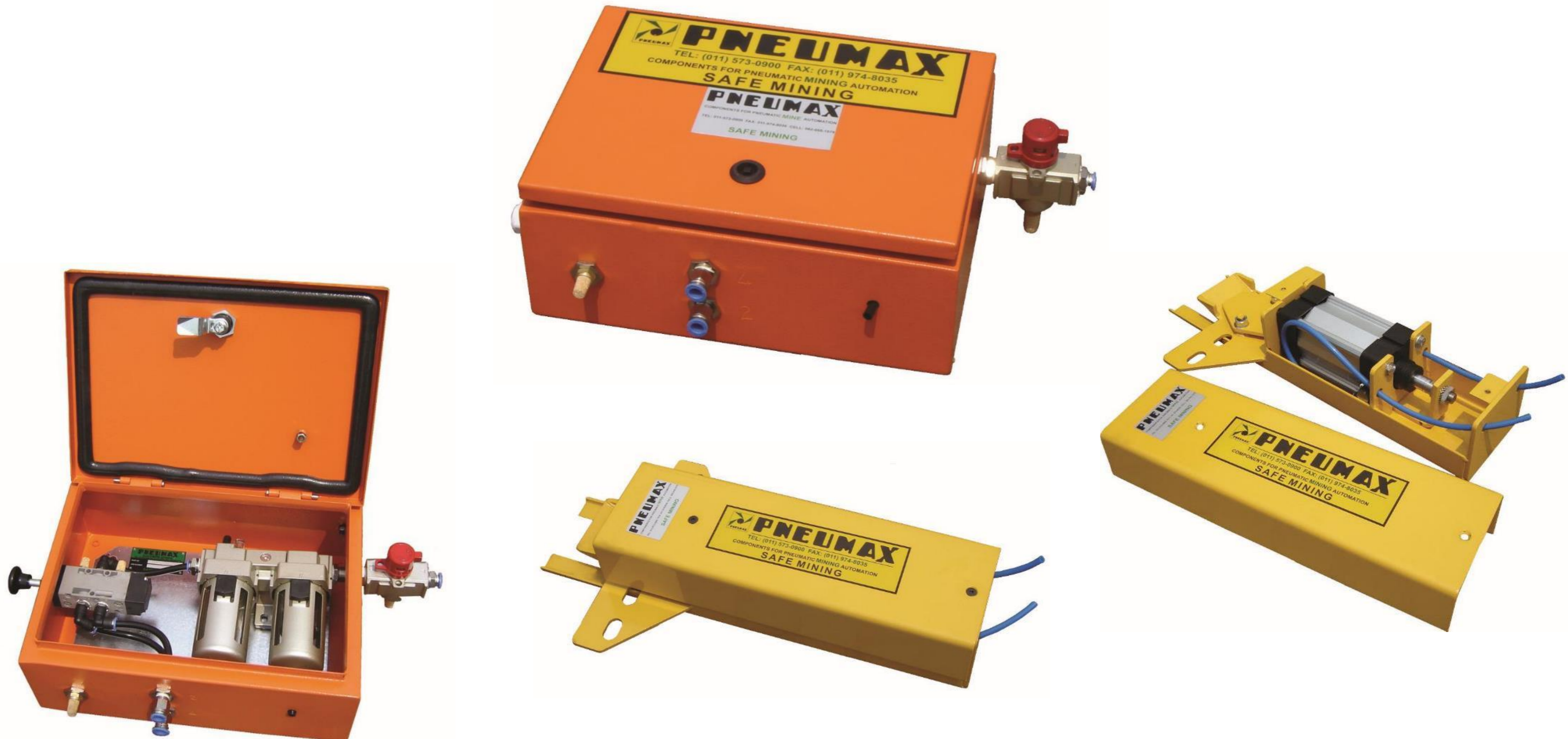

Rail Switch Applications



Lever Control Boxes

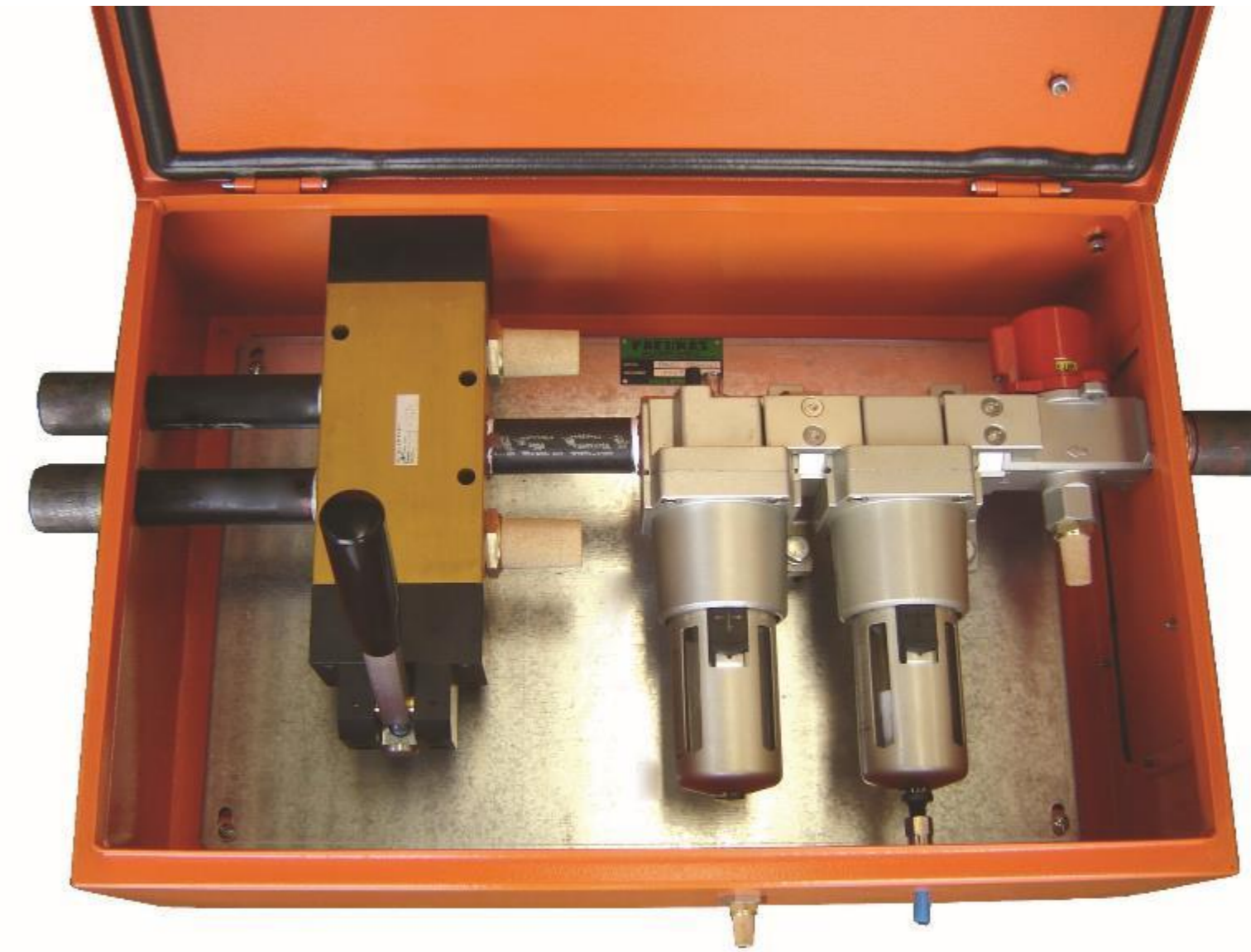

Pneumatic Electric Control Boxes/ Light Systems



Vertical Rail Switches & Stop Blocks



Stop Blocks



Vertical Rail Switch – Side Wall



Special Enclosures

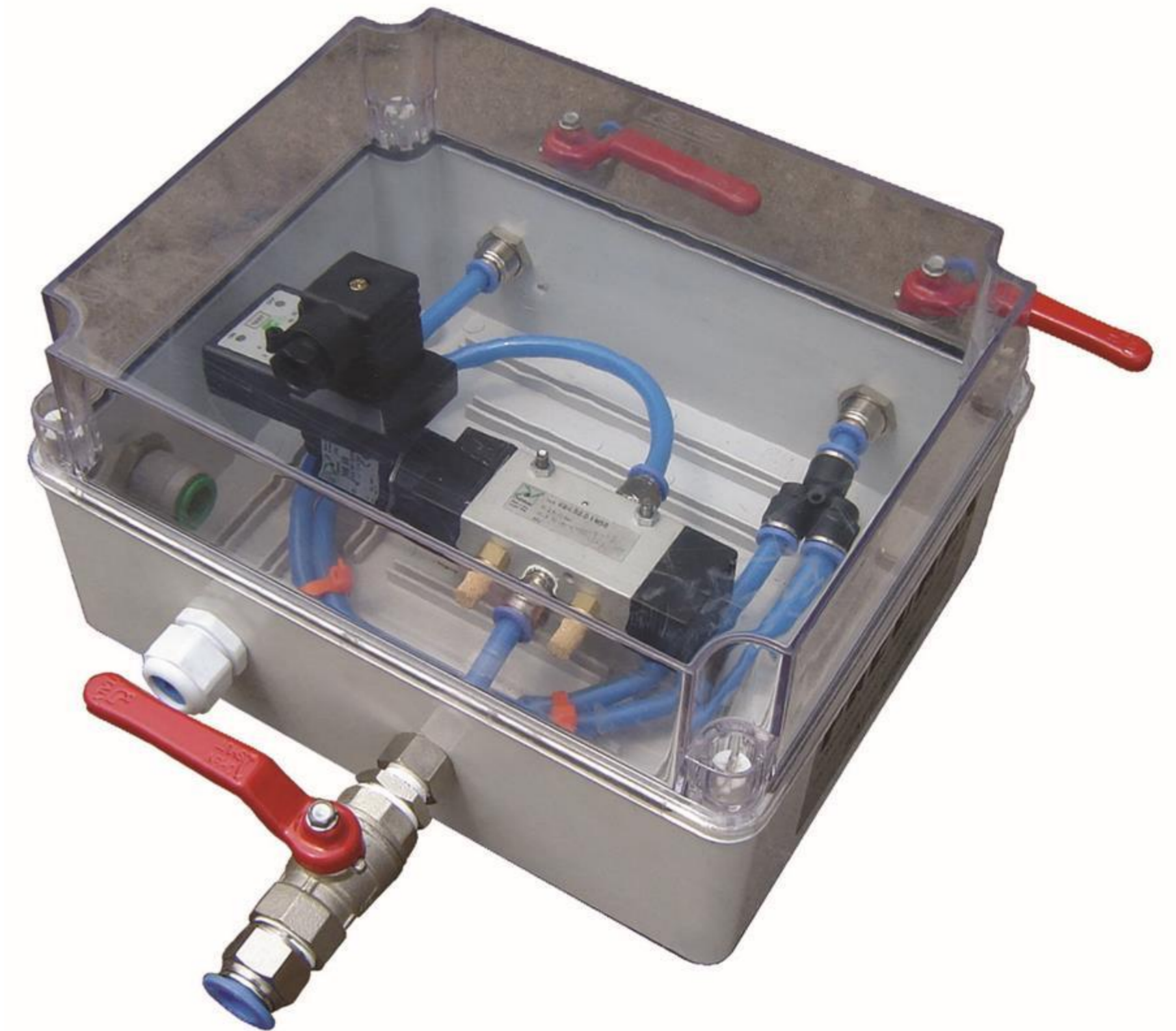



Automotive Workshops

Pneumatic Piston Pumps | Oil Bars | Service Columns | Waste Oil Drainers | Drip Trays | Tyre Inflators | Hose Reels | Central Lubrication systems | Grease Pumps | Oil Stations | Washers | Storage

Typical Workshop – we got you covered

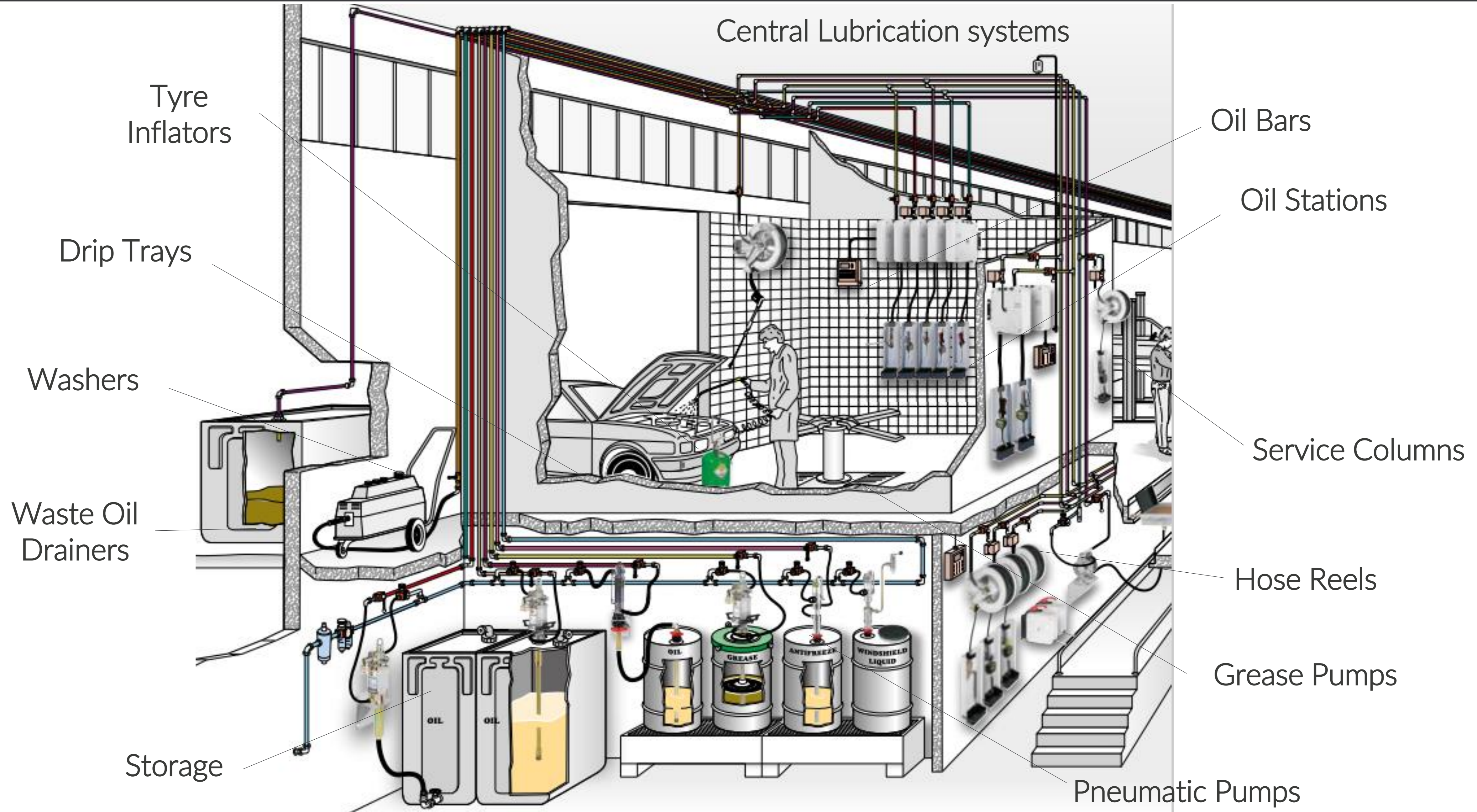

Tyre Inflators



Manual Charge



Auto Charge



Air Accessories

Drip Trays & Suction Drainers



Wheel Mounted Suction Drainers



Gravity Drainers

Washers & Sprayers



Air Operated Oil Dispensers

Grease Pumps



Hand-operated grease pump



Foot Operated Grease Pumps



Portable grease dispenser



Manual Grease Compressors

Service Columns



Brake Bleeding

Electronic Brake Bleeders



Manual Brake Bleeders



Accessories



Storage

Gravity Drainers

Central Lubrication

Air Operated Oil Dispensers

Oil Bars



Portable grease dispenser

Oil Stations

Hose Reels



Hose Reels for Oil, Grease, Water, Air, Anti Freeze, AdBlue, Diesel, and Fuel

Waste Oil Drainers

Air Accessories

Pnuematic Pumps

Air Operated Oil Dispensers

Other

Brake Bleeding – Washing - Inflating



Brake – Clutch Bleeding



Washing Tank



Inflator Hose Reel

Drip Trays



Wheel Mounted
Suction drainers



Gravity Drainers

Oil Pumps



Diaphragm Air Pumps



Manual & Air operated drum
Pumps



Air Operated Oil Dispensers

Grease Pumps



Hand-operated grease
pump



Portable grease dispenser

Service Columns





TERMINAL EQUIPMENT

APG
INDUSTRIAL 



Liquip supplies equipment for storing and transferring bulk liquids such as petroleum and dry bulk. We specialise in terminal, tanker and aviation markets, offering best-in-class products such as loading arms, ground monitors, meters and pumping systems



Silea has over 50 years been helping companies to solve the problem of liquid transfer (hydrocarbons, industrial liquids, chemicals and food). Silea designs and produces standard and customizable products for your every need. This is the goal of Sileas daily commitment



Established in 1996, Alptec Safety Equipment Co., Ltd specializes in the design, manufacture, and supply of high-quality Overfill Protection as well as Static Grounding Systems and Earthing Clamps, Reels and accessories for the chemical, petrochemical, oil and gas and process industries that transport, store, transfer and use solvents or combustible liquids in hazardous areas



Pro Flow is a APG brand with NRCS approvals geared towards quality bulk fuel transfer equipment. Through innovation and constant development Pro Flow has become synonymous with affordable quality pumps, meters, and related equipment



We strongly believe in connections. Since 1997 we have developed, produced and manufactured innovative coupling products such as breakaway couplings, dry disconnect couplings, dry gas couplings and LNG solutions for some of the world's most demanding industries when it comes to safety. That means solutions beyond expectations – all the way



Top Loading Arms

- Long Reach Arms
- Pantograph Loading Arms
- Vapour Recovery



LPG Loading Arms



Bottom Loading Arms

- A-Frame Loading Arm
- Low Profile Loading Arm
- Overhead Arm
- Loading and Unloading Arm



Overfill Protection



**Loading System
Components**



**Metering, Dispensing
and Gauging**



Vapour Recovery

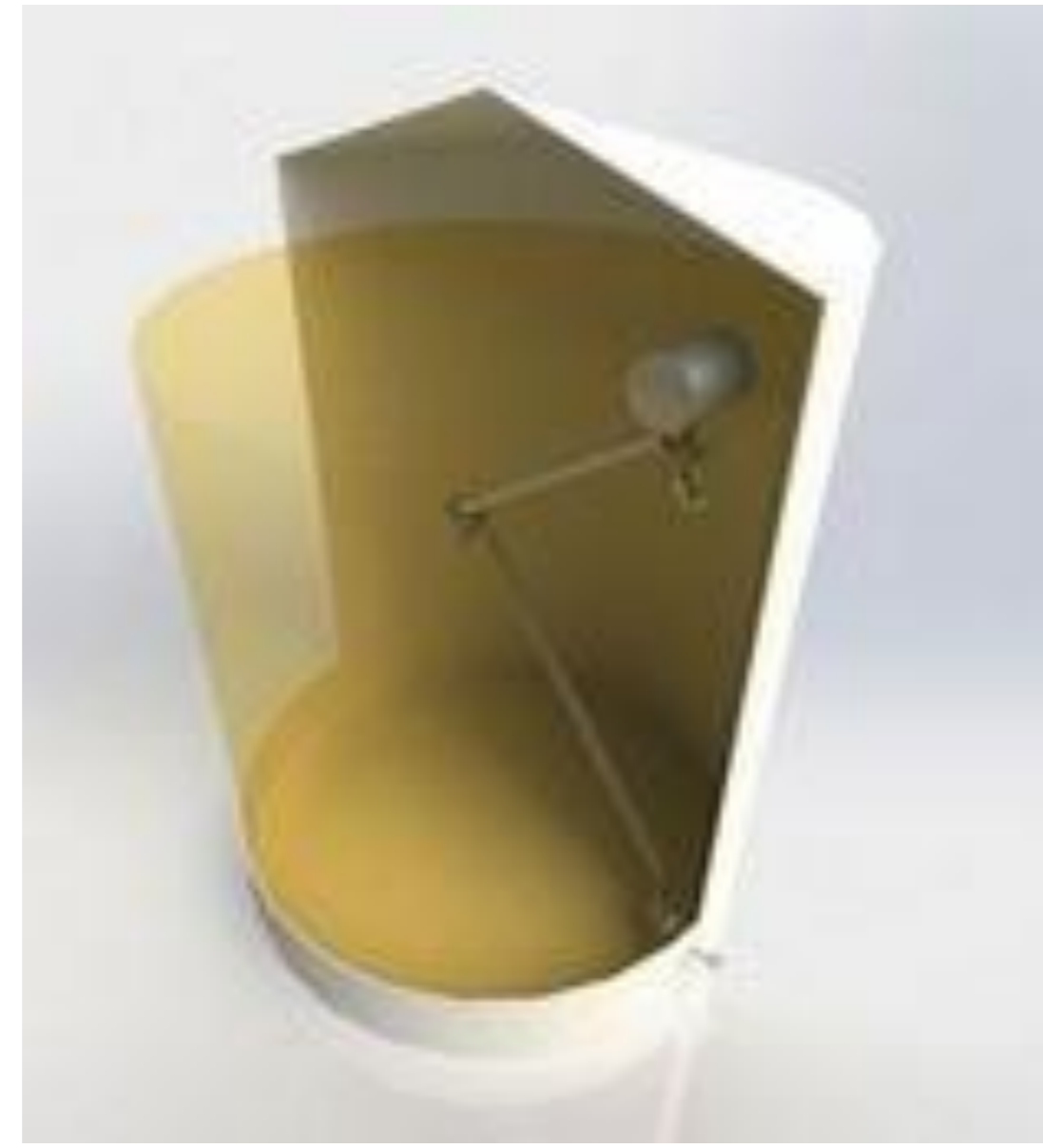
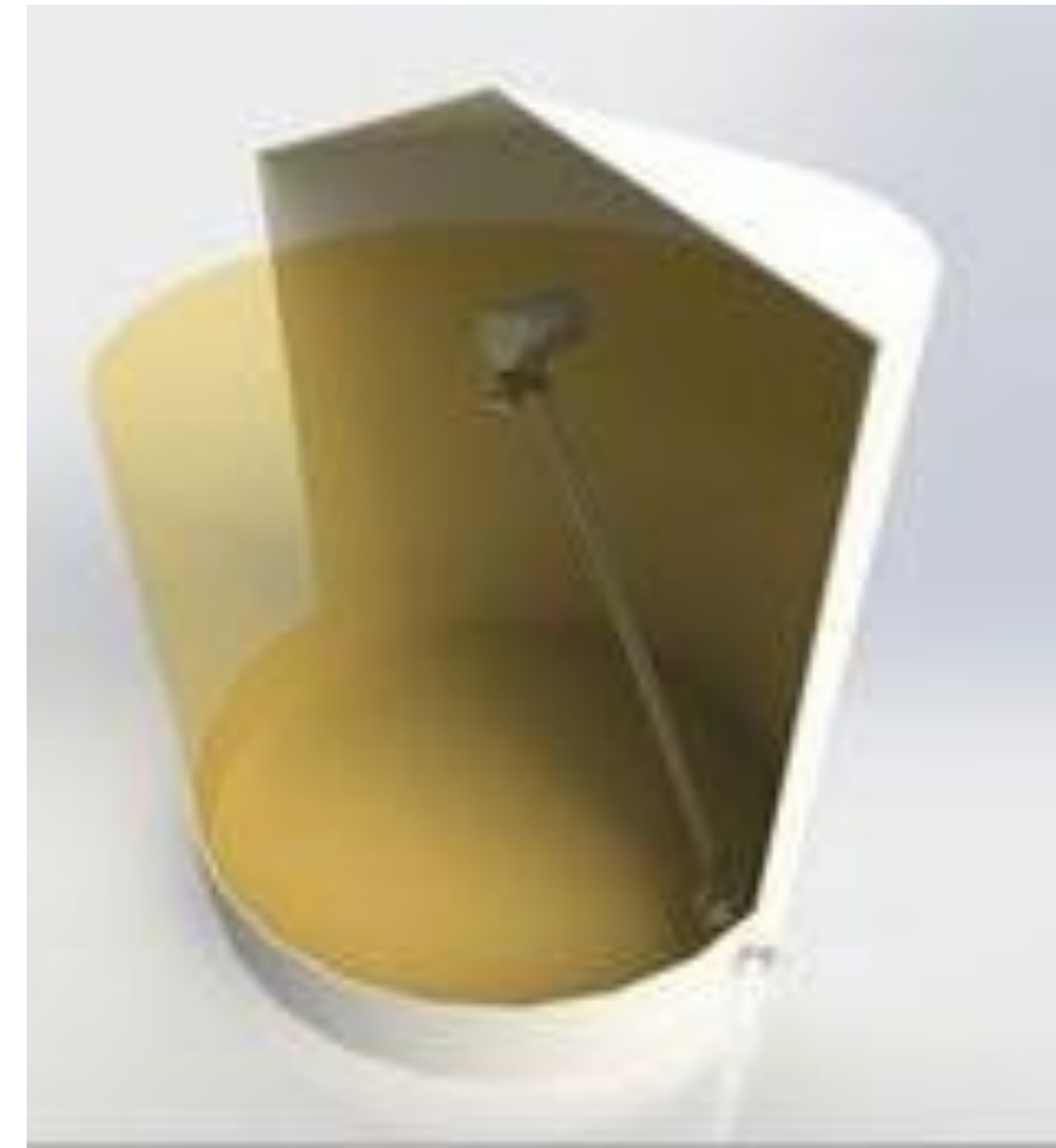

- The **series 1501** Floating Suction Units are used on underground horizontal tanks and allow that the suction, through the manhole, is always near the surface where the liquid is cleaner. Main application is on Aviation Fuels and the floating suction units are built with compatible materials.
- The **series 1502** Floating Suction Units are used on above ground vertical tanks when the diameter is higher than the height. The special design allows the suction to be always near the surface where the liquid is cleaner and hydrocarbons do not contain water, that settles in the bottom of the tank. Main application is on Aviation Fuels and the floating suction units are built with compatible materials.
- The **series 1505** Floating Suction Units are used on above ground vertical tanks when the diameter is less than the height. The special design allows the suction to be always near the surface where the liquid is cleaner and hydrocarbons do not contain water that settles in the bottom of the tank. Main application is on Aviation Fuels and the floating suction units are built with compatible materials.



Static/Anti-Static
Grounding Assemblies



ATEX Approved Intrinsically Safe
Dual Core 316L SS Anti-Static
Grounding Clamps



ATEX Approved Static/Anti-Static
Grounding Aluminium Clamps





Leakage Detectors



Overfill Protection System



Retractable Grounding Reel



Float Type Liquid High Level Alarm

Density Meters

It is suitable for liquid density measurement in petrochemical, pharmaceutical and food industries, and can completely replace the traditional manual density measurement.



Lazer Methane Detector

Portable Gas Leak Detector is an instrument used to detect indoor pipe network leaks, and is suitable for pipe network service technicians. It is mainly used to directly check the pipes, connections and flanges of the following devices:

- 1) visible pipelines indoors;
- 2) Detection holes for underground pipelines;
- 3) Regulator box.

The mass flowmeter uses the Coriolis effect principle. By measuring the Coriolis force of fluid received in the tube, it can directly measure the mass flow of the fluid in the tube. The Coriolis force is only related to the mass and speed of the fluid. In principle, it eliminates the influence of temperature, pressure, fluid state, density and other parameters on the measurement accuracy, and directly obtains the accuracy flow value and density value of various media under complex environmental conditions. It doesn't need to go through the conversion of intermediate parameters, avoiding measurement errors due to the intermediate conversion, so as to realize the high-precision and accurate measurement.





Positive Displacement Rotary Vane Pump

Self Priming Centrifugal Pump



Supply of custom cut and fitted fuel transfer hose assemblies.

Pressure Test Certificates Included.

Application:

For use in tank truck and in-plant operations.

Product Identification Hose Covers



Fuel Composite Hose



Fuel Loading and Unloading Hose



Dry Disconnect Couplings

The standardized interface to STANAG 3756 with its bayonet coupling principle has been widely accepted in the industry. Application for industrial process plant, road and rail tankers, IBC containers, pharmaceutical and petrochemical industries etc.



Safety Breakaway Couplings

Safety Breakaway Couplings are used to prevent pull away accidents, protect terminal and loading/unloading equipment and eliminated unwanted product release. The breakaway couplings have a predefined breaking point which will break at a determined break-load where upon the internal valves will automatically close flow on both sides.



Dry Aviation Couplings

Quick and safe connections of hoses and loading arms to mobile and stationary tanks, tank trucks, dispenser vehicles, under pressure and with minimized liquid loss. Dry aviation couplings according to ISO 45 / STANAG 3105.



Process Automation

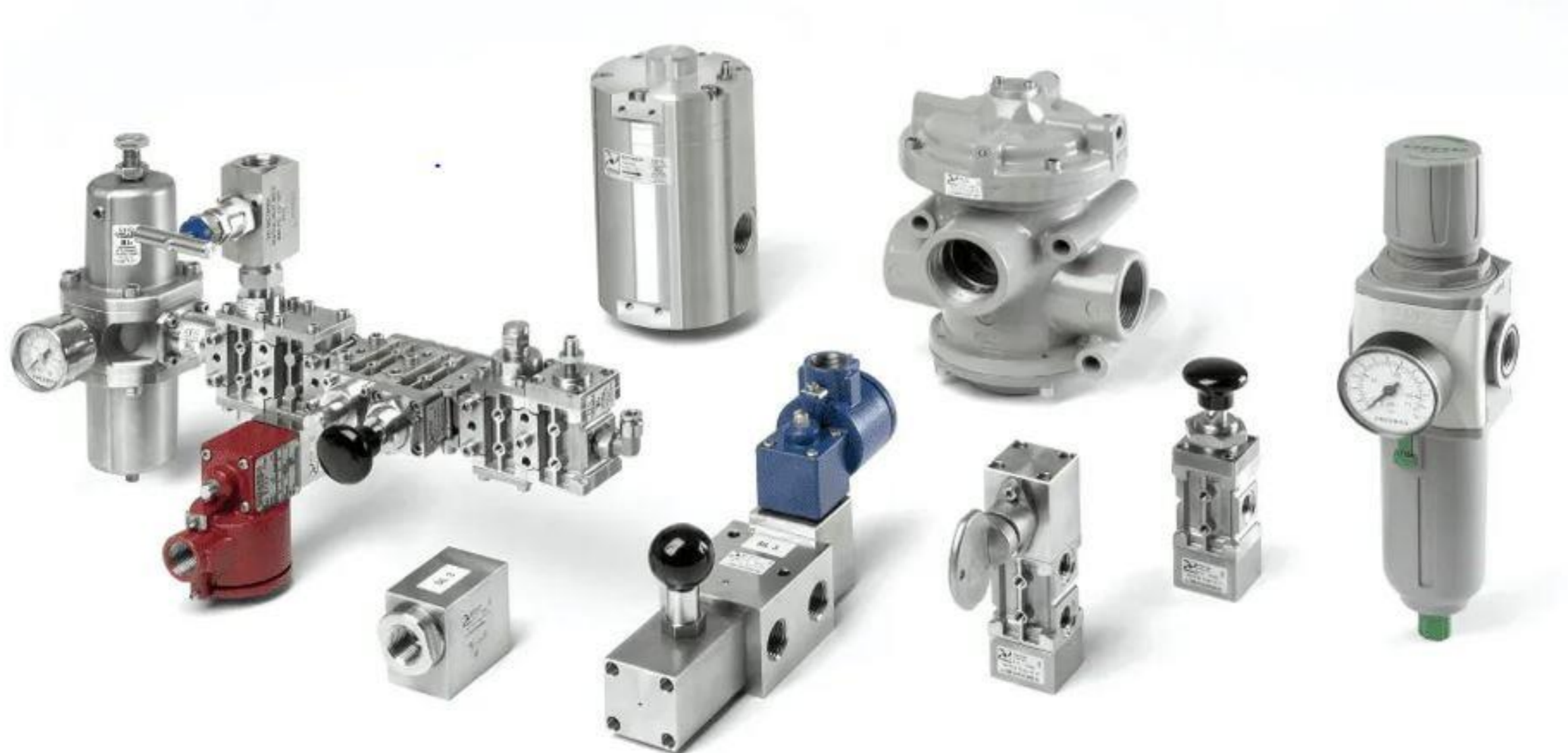

- Valves and solenoid valves for fluids
- FRL and booster
- Valves and solenoid valves Steel line – Stainless Steel
- Pneumatic actuated valves - Aluminium
- Valves and solenoid valves poppet system – Aluminium
- Valves and solenoid valves with NAMUR interface
- Manifold configurator

Pneumatic Valves



Pneumatic Fittings

- Plastic
- Metal
- Stainless Steel



Pneumatic Tubing

- Teflon
- Polyurethane
- Nylon





APG Industrial provides an extensive range of workshop and repair service for Petrochemical, Gas, Aviation, Cryogenics and Chemical Industries.

Maintenance and Workshop service for both transport and terminal including service / replacement or repair of filling and dispensing equipment.



Hydrostatic Hose Pressure Testing On and Off-site





TANKER EQUIPMENT

APG
INDUSTRIAL 

Manhole / Hatches



Emergency Inspection Hatches



Hatch Weather Covers



Pressure Vacuum Vent



Vapour Recovery



Top Operators



The Team



Lelani de Villiers
Sales & Product
Manager



Steven de Villiers
Business Development &
Projects Manager



Juan Verster
Technical & Workshop
Manager



Elias Lishi
Internal Sales



Piet Mahlangu
Internal Sales



Phillip Mdluli
Internal Sales



Phineas Mohohoma
Internal Sales

Contact Us

Sales and Product Manager

Lelani De Villiers
Email: Lelani.devilliers@apgonline.co.za
Office Phone: +27 (11) 627 2505
Mobile: +27 83 709 3618
Web: www.apgindustrial.co.za

Business Development

Steven De Villiers
Email: steven.devilliers@apgonline.co.za
Office Phone: +27 (11) 627 2505
Mobile: +27 73 131 4074
Web: www.apgindustrial.co.za

Technical Services

Juan Verster
Email: juan.verster@apgonline.co.za
Office Phone: +27 (11) 627 2505
Web: www.apgindustrial.co.za

Internal Sales Support

Elias Lishi
Email: elias.lishi@apgonline.co.za
Office Phone: +27 (11) 627 2505
Web: www.apgindustrial.co.za

Internal Sales Support

Piet Mahlangu
Email: john.mahlangu@apgonline.co.za
Office Phone: +27 (11) 627 2505
Web: www.apgindustrial.co.za