

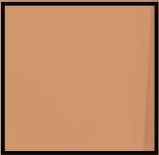

ALLOYMICA®
Architectural Facade Solutions

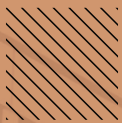

Exceptional A1 rated non-combustible products



ALLOYMICA® /A1

Architectural Solid Aluminium Sheet
A1 Series



Fire Rated
A1



Recycleble
materials



ISO Certified
ECCA and
ASTM Tested



CREATIVE ARCHITECTURAL FACADE EXPERIENCE



Alloymica® is a luxury pre-painted aluminium product designed for high-end Architecture. We partnered with one of the world's largest and most advanced pre-painted metal manufacturers to develop Alloymica®/A1.

Alloymica®/A1 is non-combustible aluminium solid panel featuring:

- High quality pre-paint coatings in variety of painting technology such as PVDF, FEVE, HDPE, and MVP. All coating methods produced on a continuous coating line that provides consistency and longevity across the surface. Coating process conforms to AAMA 2605 and ECCA guidelines.
- A1 rating, non-combustible in accordance with EN 13501-1.
- Alloymica® is available in AA3003 and in pre-anodized AA5005.
- Alloymica® comes with a standard 10 year warranty.

ALLOYMICA®





Technical Properties	Pre-paint Coil Coating	Anodised
Alloy	AA 3003, AA 5005 (others possible)	AA 5005
Temper	H14, H24	H12, H14, H24
Standard Thickness	0.5mm - 3.0mm	1.0mm - 3.0mm
Standard Widths	1000mm - 1500mm	1000mm - 1500mm
Standard Length	≤ 6000mm	≤ 6000mm
Panel Weight	8.1 Kg/m ²	8.1 Kg/m ²
Tensile Strength	140–185 MPa	125–185 MPa
Proof Stress 0.2%	≥ 110	≥ 95 - 110 depends on thickness
Elongation	A ₅₀ ≥ 5%	A ≥ 2 - 5% depends on thickness
Linear Expansion	2.4 mm/m at 100 °C temperature difference	2.4 mm/m at 100 °C temperature difference
Surface color	PVDF, FEVE, MVP, Duragloss	Anodised
Gloss	25–40 Gloss Unit	Depending on colour
Coating Thickness**	25–45µm	
Anodising Layer		10 - 20µm
Fire Classification	A1	A1

** Coating thickness varies for different surface finishes.



Eco-Friendly

Alloymica expresses the nature's pattern and texture. Recycling is possible due to the characteristics of aluminum.



Workability

Pre-painted aluminium sheets are easy to work with.



High performance

Ultra durable coil coating systems that comply with AAMA2605, this warrants atleast 10 years of color performance.



Cost effective

Luxury textures and color with high durability come in an affordable offer. Alloymica allows designers to meet the value engineering of any architectural projects.



Aesthetic texture and color

Truly unique and realistic textures can be realized by using Alloymica.



Up to 20 year warranty

Alloymica's high quality aluminium sheets guarantee performance up to the maximum of 20 years.





The various patterns and textures of the Alloymica satisfy the requirements of every user who desires to create a unique and beautiful architecture.

It also plays a great role in enhancing the lifespan and value of the architecture; owing to its ultra-high weatherproof varnish and world's-best plating technological finish.

Accomplish your creative design dreams with Alloymica.



Facade cladding installation examples:

Cassette façades with invisible fixings

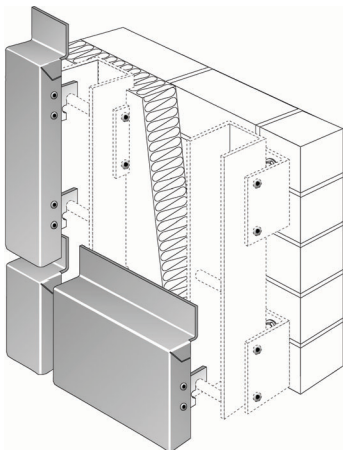

Panel with concealed connection

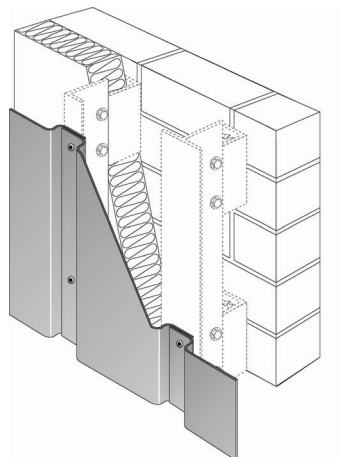

Flat sheet / Riveted

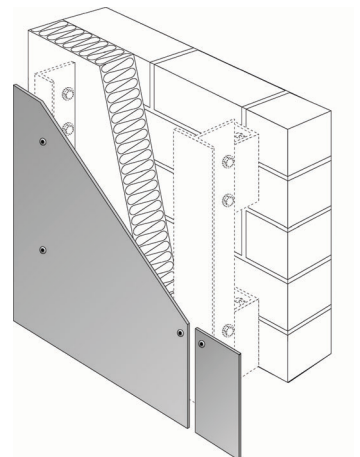



Many color coating categories to choose from to meet the creativity and design requirements.

Colour Category

- Solid
- Wood
- Stone
- Natural
- Metals
- Anodised

Paint quality

- PVDF 70/30
- FEVE
- High-Definition Polyester (HDP)
- Modified Vinyl Polyester (MVP)

Gloss

- Super gloss
- Matt
- Matt

WOOD

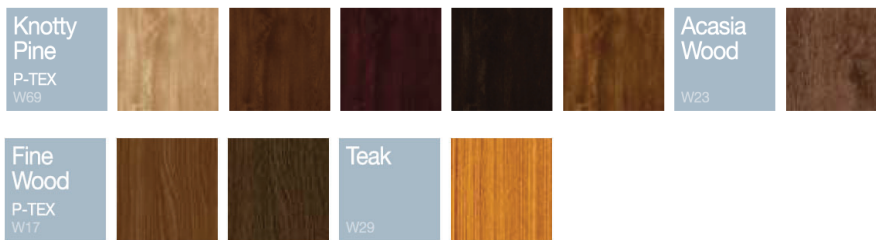

STONE

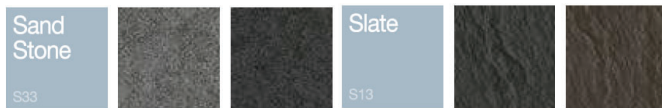

CORTEN



ZINC

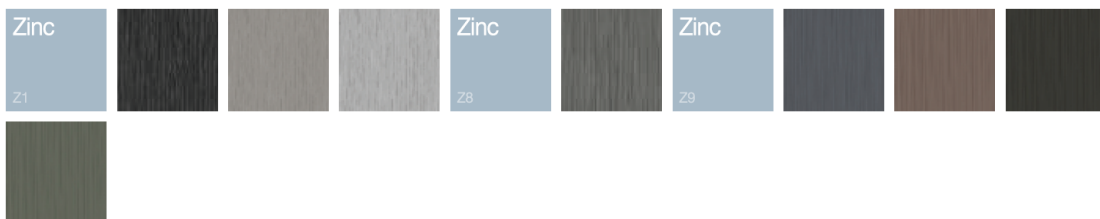

HAIR LINE





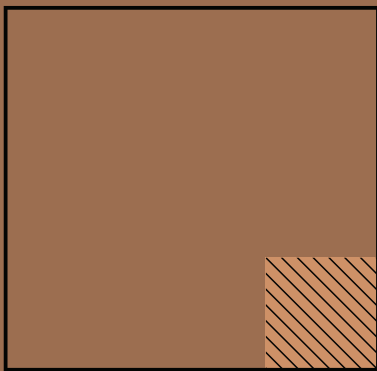

Globally Sourced
Fire Rated A1
Non-combustible Solid Aluminium Sheets

WWW.ALLOYMICA.COM



Address

Sales Office:
1334/18-19 Rama 3 Rd. Soi 52
Chongnonsee, Yannawa,
Bangkok, Thailand 10120



Phone

+66 2 2947479