

# COUNTER-BALANCED STACKER

 **TOYOTA**  
**INDUSTRIAL EQUIPMENT**  
REACH NEW HEIGHTS

## IT REALLY STACKS UP

- ▶ 2000 - 4000 lb. Capacity
- ▶ 9 - 10 ft. Aisle Accessibility
- ▶ Up to 180 in. Lift Height
- ▶ Heavy-Duty Transmission
- ▶ 24-Volt Motor
- ▶ 37 fpm Lift Speed



6BWC10-20

CLASS  
**3**

ELECTRIC PALLET JACKS/STACKERS/TOW TRACTORS

[ToyotaForklift.com](http://ToyotaForklift.com)

# GO WHERE OT FEAR TO STAC

**THE TOYOTA COUNTER-BALANCED STACKER.** Loads too wide for other stackers in aisles too tight for sit-down forklifts. That's the Counter-Balanced Stacker's sweet spot. Makes sense, given that it's only 34.1 inches wide. Makes even more sense when you factor in a lift height of up to 180 inches, and an ability to store and stack loads weighing up to 4000 pounds. At which point adding the Counter-Balanced Stacker to your fleet as an ideal indoor utility player makes perfect sense.

## COUNTER-BALANCED STACKER ADVANTAGES

- ▶ **DRIVE-IN PALLET ACCESS** accelerates cycle times and improves overall productivity
- ▶ **EASY-TO-OPERATE CONTROLS** anchored by an ergonomic multifunction control handle

- ▶ **LOAD-SENSING TORSION BAR** for easier steering and reduced operator fatigue

- ▶ **RUGGED CONSTRUCTION** for increased durability and reliability, and a longer useful lifespan

- ▶ **ABILITY TO HANDLE HEAVY LOADS** up to 4000 pounds, quickly and efficiently

- ▶ **HIGH-VISIBILITY MAST** allows operator to clearly see fork tips and wider work area

- ▶ **NO TOOLS REQUIRED SERVICE DOOR** for easy access to all major components for inspection and maintenance



# HERS

UP TO **4000** LB.  
CAPACITY

# CK

▶ **HANDLE-MOUNTED ELECTRIC LIFT/LOWER CONTROLS** for easy access, with pressure-compensated valve for constant lowering in all conditions

▶ **LARGE ERGONOMIC DUAL THUMBWHEELS** for easy thumb activation of all controls with leak-proof cast iron pump body

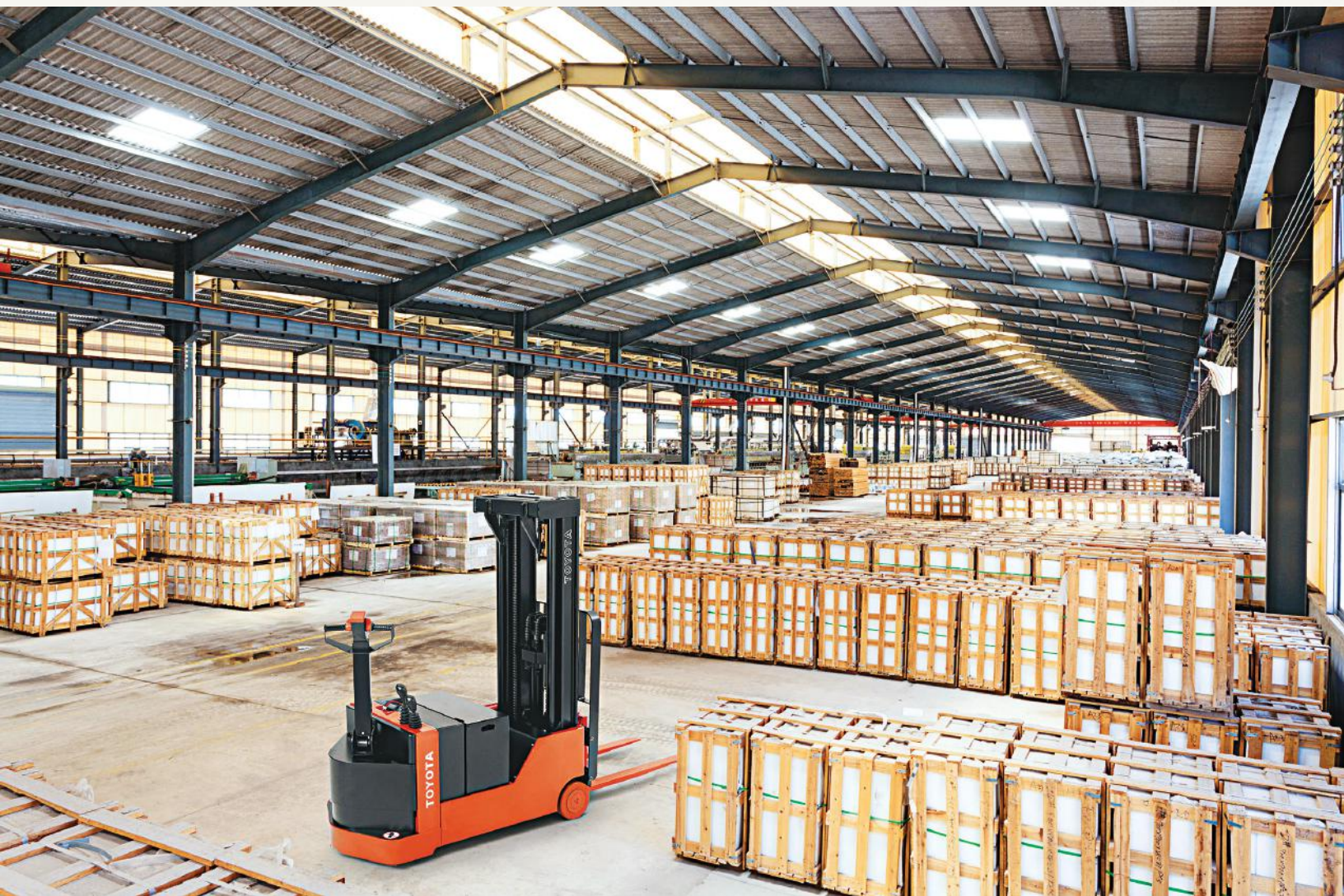

# COUNTER-BALANCED STACKER

**CAPACITY**  
2000 - 4000 LBS.

**WHEELBASE**  
47 - 58.6 IN.

**LOAD CENTER**  
24 IN.

## INDUSTRIES



Cold Storage



Distribution



Food Storage



General Manufacturing



General Warehousing



Retail

## STANDARD FEATURES

### PERFORMANCE

- 24-Volt electrical system
- SB-175 connector (red)
- On/off key switch
- UL-approved model type "E"
- Electric raise & lower controls in operator handle
- Manual raise & lower controls on console
- MOSFET programmable controller with Separately Excited (SepEx™) shunt wound drive motor & self-diagnostics

### BODY/EXTERIOR DESIGN

- Electric horn
- 30"-wide ITA Class II hook-type carriage
- 42"-long pallet forks
- 48"-high load backrest extension
- Mast tilt (3° forward/8° backward)
- High-visibility mast
- 10"-dia. x 4"-wide rubber drive tire
- 10.5"-dia. x 5"-wide polyurethane load wheels
- 32.3" x 13.3" x open height battery compartment
- Stabilizing casters
- Spring-loaded torsion bar suspension with automatic load sensing
- Pressure overload relief valve & lowering control fuses
- Easy access service cover

### OPERABILITY & ERGONOMICS

- Emergency power disconnect switch
- Automatic resetting circuit breaker
- Reverse polarity protection contactor
- Mechanical drum brake
- Directional thumb control
- Direction reverse switch in control handle
- Power on self test

## OPTIONAL EQUIPMENT

- 30," 36" or 48" fork lengths
- 36" or 44" reduced height load backrest extension
- Twist grip control handle in place of thumb control<sup>1</sup>
- 2" sideshift each way (32" or 33" base leg inside dimension)<sup>2</sup>
- 3" sideshift each way (minimum 34" base leg inside dimension or wider)<sup>2</sup>
- Various flashing lights
- Various strobe lights
- Audible travel alarm
- Hour meter<sup>5</sup>
- Battery discharge indicator (meter type)<sup>5</sup>
- Battery discharge indicator with hour meter in combination gauge (with or without lift interrupt)<sup>5</sup>
- Battery compartment rollers (roller height 9.8" — allows exit to either side)
- Toggle switch in place of key switch
- Various battery connectors
- Various drive tire compounds
- UL-approved model type "EE" without enclosed battery compartment<sup>3</sup>
- Corrosion conditioning
- Cold storage conditioning (includes corrosion protection conditioning)
- Auxiliary hydraulic function valve & hoses with carriage mounted termination<sup>4</sup>

## RIGHT-ANGLE STACKING AISLE REQUIREMENTS

LOAD WIDTH	LOAD LENGTH														
	6BWC10					6BWC15					6BWC20				
	30 (762)	36 (914)	40 (1016)	42 (1067)	48 (1219)	30 (762)	36 (914)	40 (1016)	42 (1067)	48 (1219)	30 (762)	36 (914)	40 (1016)	42 (1067)	48 (1219)
in (mm)	in (mm)														
30 (762)	92 (2337)	99 (2515)	103 (2616)	105 (2667)	111 (2820)	97 (2464)	104 (2642)	108 (2743)	110 (2794)	116 (2947)	104 (2642)	111 (2820)	115 (2921)	117 (2972)	123 (3124)
36 (914)	92 (2337)	98 (2489)	102 (2591)	105 (2667)	111 (2820)	97 (2464)	103 (2616)	108 (2743)	110 (2794)	116 (2947)	104 (2642)	110 (2794)	114 (2896)	116 (2947)	123 (3124)
40 (1016)	91 (2312)	98 (2489)	102 (2591)	104 (2642)	111 (2820)	97 (2464)	103 (2616)	107 (2718)	110 (2794)	116 (2947)	103 (2616)	110 (2794)	114 (2896)	116 (2947)	122 (3099)
42 (1067)	91 (2312)	98 (2489)	102 (2591)	104 (2642)	110 (2794)	96 (2439)	103 (2616)	107 (2718)	109 (2769)	116 (2947)	103 (2616)	110 (2794)	114 (2896)	116 (2947)	122 (3099)
48 (1219)	91 (2312)	97 (2464)	102 (2591)	104 (2642)	110 (2794)	96 (2439)	103 (2616)	107 (2718)	109 (2769)	115 (2921)	102 (2591)	109 (2769)	113 (2870)	116 (2947)	122 (3099)

<sup>1</sup> An optional twist grip control handle is available at no additional charge.

<sup>2</sup> Not available on models 6BWC10-15 equipped with 2-stage mast.

<sup>3</sup> Requires UL-approved model type "EE" rated battery with leads through cover at position "B." UL-approved model type "EE" is not available with cold storage conditioning and may reduce performance.

<sup>4</sup> Only one additional hydraulic function may be mounted: either factory mounted sideshift or factory approved, customer mounted auxiliary hydraulic attachment.

<sup>5</sup> Not available with any other optional battery discharge indicator/combination gauges.



# TRUCK SPECIFICATIONS

## MODEL NUMBERS

GENERAL DATA				6BWC10	6BWC15	6BWC20	
Load Capacity	lb (kg)			2000 (905)	3000 (1360)	4000 (1815)	
Power Type (battery type)				Battery (Lead)	Battery (Lead)	Battery (Lead)	
Operator Position				Walkie	Walkie	Walkie	
Tire Type	Drive / Caster / Load			Rubber / Polyurethane / Polyurethane	Rubber / Polyurethane / Polyurethane	Rubber / Polyurethane / Polyurethane	
Wheels (x = driven)	Drive / Caster / Load			1x / 2 / 2	1x / 2 / 2	1x / 2 / 2	
EXTERIOR DIMENSIONS				6BWC10	6BWC15	6BWC20	
<b>A</b> Maximum Fork Height (MFH) <sup>1</sup>	in (mm)			128 (3251)	128 (3251)	124 (3150)	
<b>B</b> Free-Lift	in (mm)			12 (305)	12 (305)	6 (152)	
<b>C</b> Fork Size (T x W x L)	in (mm)			1.5 x 4 x 42 (38 x 100 x 1067)	1.5 x 4 x 42 (38 x 100 x 1067)	1.75 x 4 x 42 (45 x 100 x 1067)	
<b>D</b> Fork Adjustment (minimum / maximum)	in (mm)			8.5 / 30 (215 / 760)	8.5 / 30 (215 / 760)	8.5 / 30 (215 / 760)	
<b>E</b> Tilt Range (mast tilt)(forward / backward)	deg			3 / 8	3 / 8	3 / 8	
<b>F</b> Head Length (length to fork face)	in (mm)			64.8 (1646)	70.1 (1781)	76.6 (1945)	
<b>G</b> Fork Lowered Height	in (mm)			2 (50)	2 (50)	2 (50)	
<b>H</b> Mast Lowered Height	in (mm)			83 (2108)	83 (2108)	83 (2108)	
<b>I</b> Power Unit Width	in (mm)			34.1 (866)	34.1 (866)	34.1 (866)	
<b>J</b> Power Unit Height	in (mm)			32.5 (826)	32.5 (826)	32.5 (826)	
<b>K</b> Turning Radius	in (mm)			56.7 (1440)	62 (1575)	68.3 (1735)	
<b>L</b> Load Distance	in (mm)			8.1 (205)	8.1 (205)	8.3 (210)	
Mast Extended Height	in (mm)			176 (4470)	176 (4470)	172 (4369)	
Basic Right-Angle Stacking Aisle Width				Reference chart on bottom of page 04 for Aisle Width Requirements for Right-Angle Stacking			
PERFORMANCE DATA				6BWC10	6BWC15	6BWC20	
Speeds	Maximum Travel (forward / reverse)	Full Load	mph (km/h)	2.9 (4.7)	3.0 (4.8)	2.8 (4.5)	
		No Load	mph (km/h)	3.2 (5.1)	3.4 (5.5)	3.3 (5.3)	
	Lifting	Full Load	fpm (mm/sec)	37 (188)	32 (163)	27 (137)	
		No Load	fpm (mm/sec)	49 (249)	49 (249)	49 (249)	
	Lowering	Full Load	fpm (mm/sec)	60 (305)	60 (305)	60 (305)	
		No Load	fpm (mm/sec)	44 (224)	42 (213)	42 (213)	
Gradeability <sup>2</sup>	Loaded / Unloaded	%		6 / 10	6 / 10	6 / 10	
TRUCK WEIGHTS				6BWC10	6BWC15	6BWC20	
Total Weight Without Battery				lb (kg)	3600 (1633)	4800 (2177)	5800 (2630)
Weight Distribution (with standard battery)	Full Load	Front	lb (kg)	—	—	—	
		Rear	lb (kg)	—	—	—	
	No Load	Front	lb (kg)	—	—	—	
		Rear	lb (kg)	—	—	—	
TIRES				6BWC10	6BWC15	6BWC20	
Tire Size (dia. x width)	Drive	in (mm)		10.5 x 5 (267 x 127)	10.5 x 5 (267 x 127)	10.5 x 5 (267 x 127)	
	Caster	in (mm)		4 x 2.5 (102 x 64)	4 x 2.5 (102 x 64)	4 x 2.5 (102 x 64)	
	Load	in (mm)		10 x 4 (254 x 102)	10 x 4 (254 x 102)	10 x 4 (254 x 102)	
Wheelbase	in (mm)		47 (1194)	52.3 (1328)	58.6 (1488)		
Suspension			Automatic Load-Sensing Torsion Bar Suspension	Automatic Load-Sensing Torsion Bar Suspension	Automatic Load-Sensing Torsion Bar Suspension		
Underclearance (center of wheelbase)	in (mm)		3.6 (91.5)	3.6 (91.5)	3.6 (91.5)		
Grade Clearance	%		10	10	10		
Brake			Mechanical Drum Brake	Mechanical Drum Brake	Mechanical Drum Brake		
POWER SYSTEM				6BWC10	6BWC15	6BWC20	
Battery Compartment	Length	in (mm)		32.3 (820)	32.3 (820)	32.3 (820)	
	Width	in (mm)		13.3 (338)	13.3 (338)	13.3 (338)	
	Height	in (mm)		Open	Open	Open	
Battery (6-hour rating)	Voltage / Capacity	V / Ah		24 (650)	24 (650)	24 (650)	
	Weight (minimum)	lb (kg)		950 (431)	950 (431)	950 (431)	
Electric Motors	Drive (60 min.)	hp (kW)		1.2 (.9)	3.7 (2.8)	3.7 (2.8)	
	Load Handling (5 min. 20%)	hp (kW)		4.8 (3.6)	4.8 (3.6)	4.8 (3.6)	
Control Type	Drive			Transistor	Transistor	Transistor	
	Load Handling			Electromagnetic Contactor	Electromagnetic Contactor	Electromagnetic Contactor	

<sup>1</sup> Maximum Fork Height for 2-Stage mast.

<sup>2</sup> Trucks are designed for level floor operation. Represents the ability to traverse short ramps when required.

EXTERIOR DIMENSIONS

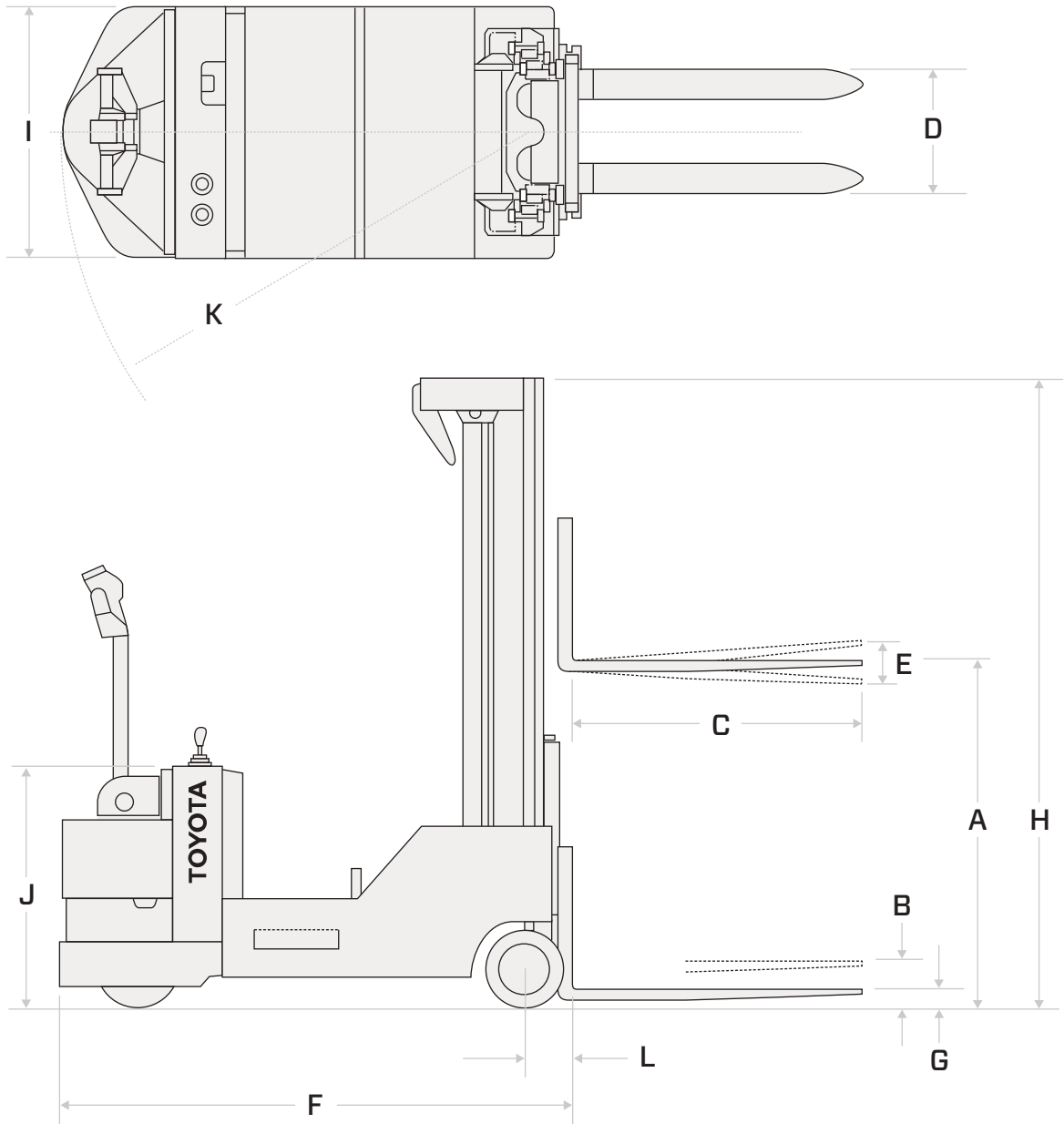

# MAST SPECIFICATIONS

MAST TYPE	MAXIMUM FORK HEIGHT (TOP OF FORKS)	OVERALL HEIGHT			TILT RANGE		LOAD CAPACITY AT 24 IN. (610 MM) LOAD CENTER (MFH / MAST LOWERED HEIGHT)	CAPACITY
		LOWERED	EXTENDED	WITH STANDARD LOAD BACKREST <sup>1</sup>	FWD	BWD		
			WITH STANDARD LOAD BACKREST <sup>1</sup>				in (mm)	in (mm)
<b>6WBC10</b>								
Wide Visible (V) <sup>2,3</sup>	104 (2650)	71 (1805)	152 (3860)	12 (305)	3	8	71 / 104 (1805 / 2650)	2000 (907)
	128 (3251)	83 (2108)	176 (4470)	12 (305)	3	8	83 / 128 (2108 / 3251)	2000 (907)
	152 (3860)	95 (2413)	200 (5080)	12 (305)	3	8	95 / 152 (2413 / 3860)	2000 (907)
Full Free-Lift 2-Stage (FV) <sup>2,3</sup>	104 (2650)	71 (1805)	152 (3860)	23 (584)	3	8	71 / 104 (1805 / 2650)	2000 (907)
	128 (3251)	83 (2108)	176 (4470)	35 (889)	3	8	83 / 128 (2108 / 3251)	2000 (907)
	152 (3860)	95 (2413)	200 (5080)	47 (1194)	3	8	95 / 152 (2413 / 3860)	2000 (907)

MAST TYPE	MAXIMUM FORK HEIGHT (TOP OF FORKS)	OVERALL HEIGHT			TILT RANGE		LOAD CAPACITY AT 24 IN. (610 MM) LOAD CENTER (MFH / MAST LOWERED HEIGHT)	CAPACITY
		LOWERED	EXTENDED	WITH STANDARD LOAD BACKREST <sup>1</sup>	FWD	BWD		
			WITH STANDARD LOAD BACKREST <sup>1</sup>				in (mm)	in (mm)
<b>6WBC15</b>								
Wide Visible (V) <sup>2,3</sup>	104 (2650)	71 (1805)	152 (3860)	12 (305)	3	8	71 / 104 (1805 / 2650)	3000 (1360)
	128 (3251)	83 (2108)	176 (4470)	12 (305)	3	8	83 / 128 (2108 / 3251)	3000 (1360)
	152 (3860)	95 (2413)	200 (5080)	12 (305)	3	8	95 / 152 (2413 / 3860)	3000 (1360)
Full Free-Lift 2-Stage (FV) <sup>2,3</sup>	104 (2650)	71 (1805)	152 (3860)	23 (584)	3	8	71 / 104 (1805 / 2650)	3000 (1360)
	128 (3251)	83 (2108)	176 (4470)	35 (889)	3	8	83 / 128 (2108 / 3251)	3000 (1360)
	152 (3860)	95 (2413)	200 (5080)	47 (1194)	3	8	95 / 152 (2413 / 3860)	3000 (1360)
Full Free-Lift 3-Stage (FSV)	150 (3810)	71 (1805)	198 (5029)	23 (584)	3	8	71 / 150 (1805 / 3810) <sup>3</sup>	3000 (1360) <sup>5</sup> 2750 (1247) <sup>6</sup>
	180 (4572)	83 (2108)	228 (5791)	35 (889)	3	8	83 / 180 (2108 / 4572)	3000 (1360) <sup>5</sup> 2750 (1247) <sup>6</sup> 2500 (1134) <sup>4,7</sup>
								3000 (1360) <sup>5</sup> 2750 (1247) <sup>6</sup>
	189 (4800)	87 (2209)	237 (6020)	39 (991)	3	8	87 / 189 (2209 / 4800)	3000 (1360) <sup>5</sup> 2750 (1247) <sup>6</sup> 2380 (1079) <sup>4,7</sup>

MAST TYPE	MAXIMUM FORK HEIGHT (TOP OF FORKS)	OVERALL HEIGHT			TILT RANGE		LOAD CAPACITY AT 24 IN. (610 MM) LOAD CENTER (MFH / MAST LOWERED HEIGHT)	CAPACITY
		LOWERED	EXTENDED	WITH STANDARD LOAD BACKREST <sup>1</sup>	FWD	BWD		
			WITH STANDARD LOAD BACKREST <sup>1</sup>				in (mm)	in (mm)
<b>6WBC20</b>								
Wide Visible (V) <sup>3</sup>	100 (2540)	71 (1805)	148 (3759)	6 (153)	3	8	71 / 100 (1805 / 2540)	4000 (1814) <sup>5</sup> 3750 (1701) <sup>6</sup>
	124 (3149)	83 (2108)	172 (4369)	6 (153)	3	8	83 / 124 (2108 / 3149)	4000 (1814) <sup>5</sup> 3750 (1701) <sup>6</sup>
	150 (3810)	95 (2413)	198 (5029)	6 (153)	3	8	95 / 150 (2413 / 3810)	4000 (1814) <sup>5</sup> 3750 (1701) <sup>6</sup>
Full Free-Lift 3-Stage (FSV)	150 (3810)	71 (1805)	198 (5029)	23 (584)	3	8	71 / 150 (1805 / 3810) <sup>3</sup>	4000 (1814) <sup>5</sup> 3750 (1701) <sup>6</sup>
	180 (4572)	83 (2108)	228 (5791)	35 (889)	3	8	83 / 180 (2108 / 4572)	4000 (1814) <sup>5</sup> 3570 (1619) <sup>6</sup> 3325 (1508) <sup>4,7</sup>
								4000 (1814) <sup>5</sup> 3520 (1596) <sup>6</sup> 3175 (1440) <sup>4,7</sup>
189 (4800)	87 (2209)	237 (6020)	39 (991)	3	8	87 / 189 (2209 / 4800)	4000 (1814) <sup>5</sup> 3520 (1596) <sup>6</sup> 3175 (1440) <sup>4,7</sup>	

1 Height of standard load backrest is 48" (1220 mm).

2 Sideshifter not available.

3 Same capacities apply when equipped with UL-approved model type "EE" option.

4 Same capacities apply when equipped with the sideshifter option.

5 Capacity without sideshifter.

6 Capacity with sideshifter.

7 Capacity with UL-approved model type "EE" option.



## COUNT ON THE LEADER

- ▶ Toyota leads in quality, durability, reliability and value, thanks to advanced technology and the world-renowned Toyota Production System.
- ▶ With the broadest and most complete set of material-handling solutions in the industry, Toyota Dealers specialize in meeting all of your needs — from a single forklift to an entire fleet.
- ▶ Toyota's industry-leading network of dealers backs every forklift with proven product support. Resources include factory-trained service technicians, Toyota Genuine Parts, and flexible leasing and financing packages through Toyota Commercial Finance.

- ▶ Toyota forklifts have ranked No. 1 in safety and quality since 2002, according to studies conducted by Peerless Research Group.

For more information, including full specs, see your Toyota Dealer or [ToyotaForklift.com](http://ToyotaForklift.com).



Some product features described herein are optional. Please consult your dealer for specifications. Details of specifications and equipment are based on information available at time of printing and may change without notice.