

QUICKCHECK™

MATH

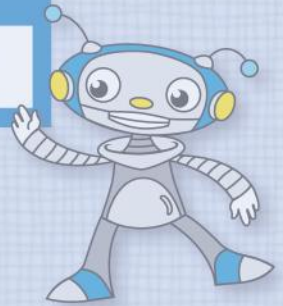

GEOMETRY AND SPATIAL SENSE

Compose and Decompose
Shapes and Figures



Strand



Book title



Grade level
Grade 1



The title of the resource relates to an Overall Expectation of the Math Curriculum. 

Student Activities

Identify and describe common two-dimensional shapes and sort and classify them by their attributes

- Match two-dimensional shapes by size..... 1
- Match triangles by size and shape..... 2
- Compare squares to circles according to size 3
- Relate each shape to its number of straight sides/vertices 4
- Relate each number to the shape with the number of straight sides/vertices 5
- Compare each shape to a another shape with the same number of straight sides/vertices

Compose patterns, pictures and designs using two-dimensional shapes

- Relate each pattern to its pattern extension.....
- Relate each pattern rule to its repeating pattern.....
- Relate each shape to the picture of which it is a part..... 9
- Relate each picture to its decomposition 10
- Relate each design composition to its decomposition
- Relate each set of shapes to its composition.....

Identify and describe shapes within other shapes

- Compare each composition of a hexagon to its decomposition..... 13
- Relate each decomposition to its composition..... 14
- Compare each composition of a square to its decomposition 15
- Compare each decomposition of a square to its composition..... 16
- Compare each composition of a triangle to its decomposition..... 17
- Compare each composition of a triangle to its decomposition.....

representation 18

Identify and describe common three-dimensional shapes and classify them

- Match each object to its three-dimensional figure..... 19
- Match cubes and rectangular prisms by size 20
- Match objects by size..... 21
- Match faces of its faces..... 22
- Match composed faces..... 23
- Match number and shape of faces 24

Groups of activities are organized around key Math concepts as they relate to the expectation noted in the title. 

The learning outcome for each activity is listed. This makes it easier for teachers to target specific concepts for teaching, diagnostic or formative assessment purposes. 

Teacher Section

How to Use QUICKCHECK Math and Tips for Success 25

Learning Connection Activity Suggestions
 Mathematical Process Expectations:
 Reflecting, Connecting and Communicating 26

How to use



GETTING READY TO USE QUICKCHECK

You need a Student Resource and a case with six tiles

Teachers will find helpful tips and Learning Connections Activity Suggestions at the back of each resource. 

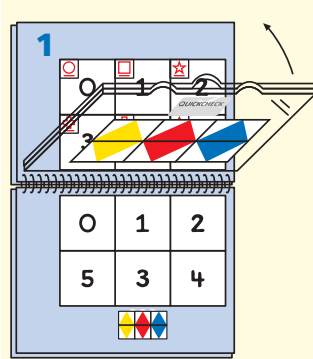
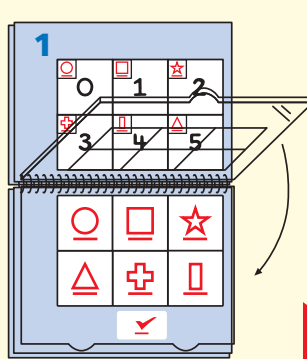
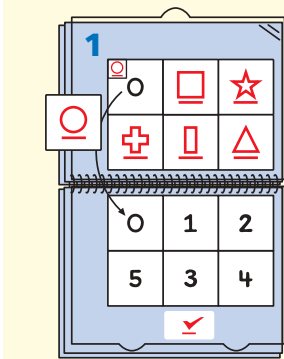
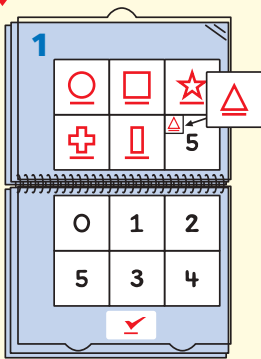

- Open the Student Resource to Activity 1.
- **Put the empty tile case over the Student Resource.**
- The CHECKMARK will cover the answer key.
- There are six squares in the top section.
- Place each tile on the square that has the same icon.

- Lift each tile to reveal the image underneath.
- Transfer each tile to its corresponding image below.

- Close the cover of the tile case.

- Flip the tile case up.
- The answer key will appear.
- The tile pattern should match the answer key.

• Watch students using QUICKCHECK Math on our website at www.ebbp.ca. Click on QUICKCHECK Math in Motion. 

1

Match two-dimensional shapes by size.

■ "What is another way you could sort these shapes? Draw a picture to show me."

The activity extension provides new information for teachers or, ideas for further development of the activity.



The activity title states the targeted learning outcome: Teachers know the purpose of the activity at a glance.



| | | |
|--|--|--|
| | | |
| | | |

Students begin each activity by matching the shape icons on the tiles, to those in the squares of the top grid of the resource.



Students move each tile from the top grid to the correct square in the bottom grid until all the tiles have been transferred.



| | | |
|--|--|--|
| | | |
| | | |

Students close the cover of the plastic case and flip it up to see if the pattern revealed on the back of the tiles matches this answer key.



If ■ appears below the activity title: Educators will then find new information or ideas for further development of the activity.

+ 23 activities
KINESIS EDUCATION

How to Use QUICKCHECK Math

1. Use QUICKCHECK Math with your students whenever you would normally use a worksheet or workbook.
 - Use it at any point in your math lesson:
 - Before/getting started
 - During/working on it
 - After/practice and consolidation.
 - You can use QUICKCHECK Math as a small group or guided activity, in pairs to promote discussion, or as an independent activity in a Math Centre.

Tips for Success

Review “Getting Ready to Use QUICKCHECK” on the first page of this book.

The CHECKMARK ✓ at the bottom of the plastic tile case shows students how to orient the case as they place it on the book on top of each activity.

To teach your students how to use QUICKCHECK Math, try a three-step approach.

1. **Match:** Place all the tiles in the top grid by matching icons.
2. **Think and Play:** Lift each tile to reveal the image beneath and then transfer the tile to the corresponding image in the lower grid.

2. Use QUICKCHECK Math as an assessment tool. The Student Activities found on the cover list learning outcomes that will help target specific concepts for **diagnostic** or **formative** assessment purposes. This Student Resource is used in conjunction with the QUICKCHECK Math Grade 1 Ongoing Assessment Teacher Resource.

Activity Extension:**If ■ appears below the activity title:**

Educators will then find new information or ideas for further development of the activity.

3. **Check:** Close the case cover. Flip the case up and check that the tile pattern matches the answer key.

When information appears below the title of an activity, use it to guide instruction and discussion, or to provide a hands-on extension of the activity.

Fold the Student Resource in half or stand it up and use the visual information as the stimulus for activities you create on your own.

See
Activity 12



Additional proposals
for the teacher

**LEARNING CONNECTION ACTIVITY SUGGESTIONS:****Mathematical Process Expectations:****Reflecting, Connecting and Communicating****Identify and describe common two-dimensional shapes and sort and classify them by their attributes**

Using a geoboard, have students make a rectangle. Now, hold it as thin as they can. “Is it still a rectangle? How do you know?” Do the same thing with a triangle.

Compose patterns, pictures and designs using two-dimensional shapes

Have students use a two-dimensional design to create a border for a picture frame. Have students make a rectangular bookmark and fill it with a design using other shapes.

Identify and describe shapes within other shapes

How many different ways can you compose a hexagon using pattern blocks? A triangle? How many different ways can you compose a triangle using pattern blocks? Using tangram pieces?

These learning connection activity suggestions are organized around the same key math concepts addressed in the 24 activities. They relate to some of the Mathematical Process Expectations used in the Math Curriculum.





Identify and describe common three-dimensional figures and sort and classify them by their attributes

Have students go on a figure hunt at school or at home. What objects did they find? Make a chart so students can summarize what they find.

| Item | Figure | Faces | Vertices |
|------------|-------------------|-------|----------|
| Tissue box | Rectangular prism | 6 | 8 |
| Ball | Sphere | 0 | 0 |
| Soup tin | Cylinder | 2 | 0 |
| | | | |
| | | | |

Have your students discuss the following with a partner:
How are shapes and figures the same?
How are they different?
Share conclusions with the class.

Complete a **KWLW** chart about shapes and figures.

What I **Know** – What I **Want** to know – What I **Learned** – What I still **Wonder**

Canada

We acknowledge the financial support of the government of Canada, for our publishing activities.



Credits page



AUTHOR KELLY DIXON PRODUCT DEVELOPMENT KELLY DIXON, PAUL KNOX, MARYLYNNE MESCHINO
CASE & TILES AND BOOKS – CONCEPT AND DESIGN BERTHELAC EDITOR MARYLYNNE MESCHINO
TEACHER REVIEWERS JOANNE BLACKBURN, OTTAWA CATHOLIC DISTRICT SCHOOL BOARD; JENINE CALDER, DURHAM CATHOLIC DISTRICT SCHOOL BOARD;
SUZANNE FOX, THAMES VALLEY DISTRICT SCHOOL BOARD
COVER DESIGN AND ILLUSTRATIONS MIKE LAJEUNESSE BOOK LAYOUT SAMIA HERRERA,
PROOFREADER CAROLYN SOUAID EDITORIAL ASSISTANT AND PRODUCTION MANAGER FRANCINE PLANTE
COMPUTER GRAPHICS JOSIANE DUQUETTE, FRANCISCA MARTINEZ GALVEZ, VALÉRIE TARDIF PRINTING SPRINTMÉDIA, JANUARY 2021
EXECUTIVE PUBLISHER PAUL BEULLAC/LÉS ÉDITIONS JULES CHÂTELAIN

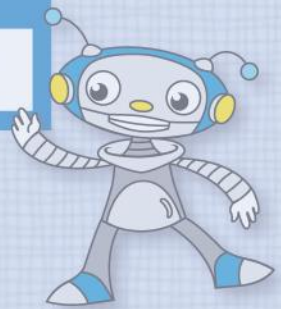

The 5 mathematical strands for the Grade 1 level



NUMBER SENSE AND NUMERATION

Solve Problems Involving the Addition and Subtraction of Single-Digit Whole Numbers



MEASUREMENT

Compare, Describe, and Order Time and Objects Using Measurable Attributes



GEOMETRY AND SPATIAL SENSE

Compose and Decompose Shapes and Figures

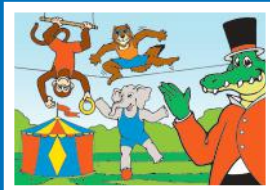

PATTERNING AND ALGEBRA

Identify, Describe and Extend Repeating Patterns



DATA MANAGEMENT AND PROBABILITY

Read and Describe Data Presented in Graphs and Pictographs



ORDER THE COMPLETE GRADE 1 PACKAGE

ISBN 978-2-7615-0285-6

Product No. 400 1137



www.ebbp.ca

Grade level
Grade 1



404 0259
Printed in Canada