



# ***General Product Catalogue***

**SEP Europe**

**2023**



© 2022 All rights reserved. SEP Europe is a registered trademark and the property of Schotman Elektro BV, its subsidiaries, and affiliated companies.



Weverstraat 4 . 9403 VJ . Assen

[www.schotmanelektro.nl](http://www.schotmanelektro.nl)  
[info@schotmanelektro.nl](mailto:info@schotmanelektro.nl)  
telefoon : 088 - 5460735





**SEP Europe**  
**General Catalogue SEP**

**Dear Valued Customer,**

We are thrilled to introduce our new SEP Europe catalog, showcasing our latest products. We have worked hard to ensure that our new catalog is a reflection of our commitment to excellence and customer satisfaction.

Our new catalog includes an extensive range of products that cater to your every need. From state-of-the-art technology to innovative solutions for everyday life, we have it all!

With a proven track record of delivering high-quality and innovative solutions, SEP Europe has firmly established itself as a leading player in the field of distribution boards. Our team of experts is dedicated to developing products that are in line with the ever-evolving demands of the industry.

We take great pride in offering our clients with superior solutions that are dependable, efficient, and cost-effective. Our products are designed and manufactured using state-of-the-art technologies, ensuring unparalleled quality and performance.

Our catalog offers a clear overview of all our SEP Europe products currently available, along with basic technical information for each product. To order any product from this catalog, simply use the 10-digit code provided with the product.

We are continually expanding our product range, and as a result, not all of our full solutions are listed in this catalog. However, please feel free to contact our resellers or our company directly for more information on our complete range of products.

Thank you for your continued support and we hope that you find this catalog to be a useful resource for all your distribution board needs.

**Always up to date;**

In this catalogue, you will find all our latest products under our own brand name, SEP Europe. We keep expanding our product range SEP Europe and will keep you informed of our new products and innovations through our website, email, and social media channels.

You can find us on our websites:

[www.schotmanelektro.eu](http://www.schotmanelektro.eu) and [www.sep-europe.com](http://www.sep-europe.com)

Sincerely,



**Jos Buijsrogge**

*Owner and Director of SEP Europe and Schotman Elektro B.V.*

**Distribution Cabinets**

**1.03 – 1.15**

CHB	-	Connectable distribution cabinets	03 - 04
TS/TF	-	Plastic distribution boxes	05 - 06
LS / LF	-	Plastic distribution boxes	07 - 08
S	-	Plastic extension boxes	09 - 10
ST	-	Protective extension boxes	11 - 12
PRO MK	-	Sheet steel distribution cabinets	13 – 14

**SL Modular Switching and Protection**

**2.03 – 2.18**

HS18	-	Isolator switches	2p   1MU (18mm) / 4p   1MU (18mm)	03 - 04
RCD18	-	RCCB	Type A   2p   1MU (18mm)	05 - 06
RCD36	-	RCCB	Type A   4p   1MU (36mm)	07 - 08
INS18	-	MCB	1p+n   1MU (18mm)	09 - 10
INS36	-	MCB	2p / 3p / 3p+n / 4p   1MU (18mm)	11 - 14
RCE1	-	RCBO	Type A   1p+n   1MU (18mm)	15 – 16
Busbar	-		pin-type 10mm <sup>2</sup> (9/18mm)	17 - 18

**FS Modular Switching and Protection**

**2.19 – 2.40**

HS1	-	Switches	1p / 2p / 3p / 4p	19 - 20
RCD1	-	RCCB	2p / 4p   Type A / Type B	21 - 26
INS1	-	MCB	1p / 1p+n / 2p / 3p / 3p+n / 4p	27 - 30
RCM	-	RCBO	1p+n / 3p+n   Type A / Type B	31 - 36
Busbar	-		Fork- and Pin type 10mm <sup>2</sup> (17.8mm)	37 - 40

**MC Modular Switching and Protection**

**2.41 – 2.45**

HS27	-	Switches	2p / 4p	41 - 42
RCD-B	-	RCCB	2p / 4p   Type B	43 - 44

**Measuring and Controlling Management**

**3.03 – 3.17**

BTR	-	Bel transformers	03 - 04
WCD	-	Sockets	05 - 06
LND	-	Emergency lights	07 - 08
CPTS	-	Timers	09 - 10
OVb	-	Surge protection devices	11 - 12
SHC	-	Contactors   pulse contactors	13 - 16
LEM	-	Energy meters	... - ...

**Busbar systems**

**4.03 – 4.39**

P	-	Closed busbar system 10mm <sup>2</sup> PIN type 17,8mm (63/100A)	03 – 06
P-G2	-	Closed busbar system 10mm <sup>2</sup> PIN type 9 / 17,8mm (63/100A)	07 – 11
F	-	Closed busbar system 10mm <sup>2</sup> FORK type 17,8mm (63/100A)	12 - 16
16P	-	Closed busbar system 16mm <sup>2</sup> PIN type 17,8mm (80/125A)	17 – 22
16P-G2	-	Closed busbar system 16mm <sup>2</sup> PIN type 9 / 17,8mm (80/125A)	23
16F	-	Closed busbar system 16mm <sup>2</sup> FORK type 17,8mm (80/125A)	24 - 28
30F	-	Closed busbar system 30mm <sup>2</sup> FORK type 17,8mm (125/210A)	29 – 30
		Connection terminals (MCB/RCCB/RCBO)	31 – 39

**Connection Materials**

**5.03 – 5.39**

AKN	-	Universal terminals	03 - 04
CK	-	Universal connection blocks	05 - 08
CVT/BVT	-	Wiring boxes	09 - 10
LTB	-	Wire-terminals	11 – 12
PDB	-	Power distribution blocks (linkable)	13 – 14
CPDB	-	Power distribution blocks	15 – 16
MDB-16	-	Connective power distribution blocks	17 – 18
KM	-	Standard wire and wire-bridges	19 - 21
LBS	-	Busbar holders	23 - 24
XTB1	-	Terminals	25 - 28
IHT	-	Ferrules	29 – 30
CLUG	-	Cable lugs, butt connectors and pin connectors	31 – 34
TA	-	Stretch tulles	35 – 36
7NC	-	Cable glands	37 – 40
CHB-S	-	Vinyl identification stickers	41





## ***DISTRIBUTION CABINETS***







---

***Distribution cabinets*****1.03 – 1.15**

---

CHB	-	Connectable distribution cabinets	03 - 04
TS/TF	-	Plastic distribution boxes	05 - 06
LS / LF	-	Plastic distribution boxes	07 - 08
S	-	Plastic extension boxes	09 - 10
ST	-	Protective extension boxes	11 - 12
PRO MK	-	Sheet steel distribution cabinets	13 - 14



**General**

The CHB distribution boxes are custom-built for household usage and feature a design optimized for the Dutch market. The enclosure conforms to a standardized width of 220mm and allows for both horizontal and vertical combination of boxes, offering enhanced installation flexibility. A removable lid protects each row of the enclosure against accidental switching of components, safeguarding the integrity of the installation.



**General parameters**

Plastic enclosures
Standard with tube connections
Including attributes (earth bar, connection bar, covers)

**Technical parameters**

Complies with		EN 61439-1 / -1 / -3
Nominal voltage	Unom	230/400VAC
Nominal current	Inom	63A
Rated insulation voltage	AC	1000V
Installation class		I
Protection degree	IP	30
Material		PC
Flammability class		V2
Glow wire test		850°C
Storage temperature		-25°C + 85°C
Operational temperature		-5°C - 70°C (with daily average <35°C)
Humidity		50...90%
EMC-type		B
Installation environment		Inside installation
Installation type		Surface mounting
Linkable		Horizontal and vertical
Number of modules each row		12
Number of rows		1, 2, 3
Earth bar		Yes
Phase bar		Yes (R S T N PE)
Din-rail type		Frame with 35mm device rail (DIN)
Entries		tube-input / cable
Color of frame		Blue
Color housing		Anthracite
Color of door		Transparent
Pollution degree		2

**Mechanical parameters**

Type	Width	Height	Depth	Weight
CHB12	220mm	205mm	105mm	
CHB24	220mm	330mm	105mm	
CHB36	220mm	410mm	105mm	
CHB12E	220mm	275mm	105mm	
CHB24E	220mm	400mm	105mm	
CHB36E	220mm	480mm	105mm	
CHB-EXT	220mm	70mm	105mm	

Order code

Including elevated tube entries

Number of rows

1	2119920012	CHB12E
2	2119920024	CHB24E
3	2119920036	CHB36E

Extension cabinets

Number of rows

1	2119910012	CHB12
2	2119910024	CHB24
3	2119910036	CHB36

Attributes

Elevated tube entries	2119910100	CHB-EXT
DIN-rail cover strips	2119910102	CHB-AFD
Blind entrance plates	2119910202	CHB-BPL
Plug connection plates	2119910201	CHB-STI
Group statement stickers	2119910105	CHB-GVS

Spare parts

Earth bars	2119910104	CHB-AR
Connection bars	2119910103	CHB-AFT
Accessories sets	2119910101	CHB-TBH
Connection plates	2119910106	CHB-KK
Transparent lids	2119910210	CHB-WD
Closing screws	2119910215	CHB-BS

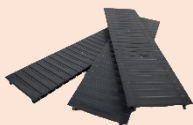



**General**

The TS/TF distribution boxes are standardized enclosures designed for distribution purposes, featuring top-up lids that offer protection for DIN-modular components. The TS distribution box is intended for surface mounting, while the TF distribution box is designed for flush mounting applications.



**General parameters**

Plastic enclosure
Cable lug entry
Wide variety of types

**Technical parameters**

Complies with		EN 61439-1 / -1 / -3
Nominal voltage	U <sub>nom</sub>	230/400VAC
Nominal current	I <sub>nom</sub>	100A
Rated insulation voltage	AC	1000V
Installation class		I
Protection degree	IP	40
Material		PC
Flammability class		V2
Glow wire test		850°C
Storage temperature		-25°C + 85°C
Operational temperature		-5°C - 70°C (with daily average <35°C)
Humidity		50...90%
EMC-type		B
Installation environment		Inside installation
Installation type		TS Surface mounting / TF Flush mounting (27mm)
Earth bar		Yes
Din-rail type		Fixed rail for 35mm device rail (DIN)
Color housing		Clear white
Color of door		Transparent
Pollution degree		2

**Mechanical parameters**

Sizes (mm)

Surface	Width	Height	Depth	Weight	Flush	Width	Height	Depth	Weight
TS4	112	200	95		TF4	136	222	60/27	
TS6	148	200	95		TF6	170	222	60/27	
TS8	184	200	95		TF8	207	222	60/27	
TS10	222	200	95		TF10	243	222	60/27	
TS12	256	200	95		TF12	279	222	60/27	
TS15	310	200	95		TF15	334	222	60/27	
TS18	365	222	95		TF18	398	251	67/27	
TS24	271	325	97		TF24	300	345	67/27	
TS36	271	462	100		TF36	300	484	67/27	



Distribution boxes		Order code			
		Surface mounting		Flush-Mounting	
Modules					
4		<b>2119300004</b>	SEP-TS4	<b>2119310004</b>	SEP-TF4
6		<b>2119300006</b>	SEP-TS6	<b>2119310006</b>	SEP-TF6
8		<b>2119300008</b>	SEP-TS8	<b>2119310008</b>	SEP-TF8
10		<b>2119300010</b>	SEP-TS10	<b>2119310010</b>	SEP-TF10
12		<b>2119300012</b>	SEP-TS12	<b>2119310012</b>	SEP-TF12
15		<b>2119300015</b>	SEP-TS15	<b>2119310015</b>	SEP-TF15
18		<b>2119300018</b>	SEP-TS18	<b>2119310018</b>	SEP-TF18
24	(2x12 rail)	<b>2119300024</b>	SEP-TS24	<b>2119310024</b>	SEP-TF24
36	(3x12 rail)	<b>2119300036</b>	SEP-TS36	<b>2119310036</b>	SEP-TF36
<b>Accessories</b>					
DIN-rail cover strip 24MU (snow white)		<b>2119000050</b>	S48-SW		
<b>Earth/Neutral brackets</b>					
Size					
4		<b>2119390004</b>	SEP-TB4		
6		<b>2119390006</b>	SEP-TB6		
8		<b>2119390008</b>	SEP-TB8		
10		<b>2119390010</b>	SEP-TB10		
12		<b>2119390012</b>	SEP-TB12		
15		<b>2119390015</b>	SEP-TB15		
18		<b>2119390018</b>	SEP-TB18		
Bracket support		<b>2119390001</b>	SEP-TB-CLIP		



**General**

The LS/LF distribution boxes are standardized enclosures designed for general distribution purposes. Equipped with DIN-rails and a full transparent (smoked) door, the enclosure provides excellent visibility of the components. The LS distribution box is intended for surface mounting, while the LF distribution box is designed for flush mounting applications.



**General parameters**

Plastic enclosure
Cable lug entry
Wide variety of types

**Technical parameters**

Complies with		EN 61439-1 / -1 / -3
Nominal voltage	Unom	230/400VAC
Nominal current	Inom	100A
Rated insulation voltage	AC	1000V
Installation class		I
Protection degree	IP	40
Material		PC
Flammability class		V2
Glow wire test		850°C
Storage temperature		-25°C + 85°C
Operational temperature		-5°C - 70°C (with daily average <35°C)
Humidity		50...90%
EMC-type		B
Installation environment		Inside installation
Installation type		TS Surface mounting / TF Flush mounting (27mm)
Earth bar		Yes
Din-rail type		Fixed rail for 35mm device rail (DIN)
Color housing		Clear white
Color of door		Transparent
Pollution degree		2

**Mechanical parameters**

Sizes (mm)

Surface	Width	Height	Depth	Weight	Flush	Width	Height	Depth	Weight
LS6	185	141	100		LF6	185	141	100/60	
LS8	230	175	100		LF8	230	175	100/60	
LS12	314	209	100		LF12	314	209	100/60	
LS16	233	290	104		LF16	233	290	103/60	
LS24	314	344	104		LF24	314	344	103/60	
LS36	314	440	104		LF36	314	440	103/60	



Distribution boxes		Order code			
		Surface mounting		Flush-Mounting	
6		<b>2119200006</b>	SEP-LS6	<b>2119210006</b>	SEP-LF6
8		<b>2119200008</b>	SEP-LS8	<b>2119210008</b>	SEP-LF8
12		<b>2119200012</b>	SEP-LS12	<b>2119210012</b>	SEP-LF12
16	(2x8 rail)	<b>2119200016</b>	SEP-LS16	<b>2119210016</b>	SEP-LF16
24	(2x12 rail)	<b>2119200024</b>	SEP-LS24	<b>2119210024</b>	SEP-LF24
36	(3x12 rail)	<b>2119200036</b>	SEP-LS36	<b>2119210036</b>	SEP-LF36
<b>Accessories</b>					
DIN-rail cover strip 24MU (snow white)		<b>2119000050</b>	S48-SW		



**General**

The S extension distribution box is a compact enclosure equipped with an integrated DIN-rail. Designed for small adaptations to electrical installations, the box's small size and space-saving design make it ideal for installations with limited mounting space.



**General parameters**

Plastic enclosure
Cable lug entry

**Technical parameters**

Complies with		EN 61439-1 / -1 / -3
Nominal voltage	Unom	230/400VAC
Nominal current	Inom	63A
Rated insulation voltage	AC	500V
Installation class		I
Protection degree	IP	20
Material		PC
Flammability class		V2
Glow wire test		850°C
Storage temperature		-25°C + 85°C
Operational temperature		-5°C - 70°C (with daily average <35°C)
Humidity		50...90%
EMC-type		B
Installation environment		Inside installation
Installation type		Surface mounted
Earth bar		No
Din-rail type		Fixed rail for 35mm device rail (DIN)
Color housing		Clear white
Pollution degree		2

**Mechanical parameters**

Type	Width	Height	Depth	Weight
S1	34mm	130mm	60mm	
S2	52mm	130mm	60mm	
S4	87mm	130mm	60mm	
S5	123mm	130mm	60mm	
S8	160mm	130mm	60mm	





<b>Distribution boxes</b>		<b>Order code</b>	
<b>Modules</b>			
1		2119400001	SEP-S1
2		2119400002	SEP-S2
4		2119400004	SEP-S4
6		2119400006	SEP-S6
8		2119400008	SEP-S8
<b>Accessories</b>			
DIN-rail cover strip 24MU (snow white)		<b>2119000050</b>	S48-SW



**General**

The ST extension distribution box is a compact enclosure equipped with an integrated DIN-rail. Some of its modules are covered with a protective lid to prevent inadvertent switching of the devices. Designed for small adaptations to electrical installations, the box's small size and space-saving design make it ideal for installations with limited mounting space.



**General parameters**

Plastic enclosure
Cable lug entry
Suited to mount on a flush-fit central box
Rapid lid closure (no screws)

**Technical parameters**

Complies with		EN 61439-1/-1/-3 EN 62208
Nominal voltage	Unom	230/400VAC
Nominal current	Inom	40A
Rated insulation voltage	AC	1000V (1500VDC)
Installation class		I
Protection degree	IP	20
Material		PC
Flammability class	UL94	V0
Glow wire test according EN 60695-2-1		960°C
Storage temperature		-25°C + 85°C
Operational temperature		-5°C - 40°C (with daily average <35°C)
Humidity		50...90%
EMC-type		B
Impact resistance		IK05
Installation environment		Inside installation
Installation type		Surface mounted
Number of entries		5x M20
Back entries possible		Yes
Earth bar		No (preparation for earth block type AST)
Din-rail type		Fixed rail for 35mm device rail (DIN)
Modules		3/6 + 2,5 – 3/6 + 5
Color housing		Broken white (RAL9010)
Color lid		Transparent blue
Pollution degree		2

**Mechanical parameters**

Type	Width	Height	Depth	Weight
ST3-V1	123mm	180mm	89mm	0,228 kg
ST3-V2	168,5mm	180mm	89mm	0,282 kg
ST6-V1	183mm	180mm	91mm	0,312 kg
ST6-V2	228mm	180mm	91mm	0,364 kg

**Order code**

**Distribution boxes**

**Modules**

3 (behind lid) + 2,5

**2119600031** ST3-V1

3 (behind lid) + 5

**2119600032** ST3-V2

6 (behind lid) + 2,5

**2119600061** ST6-V1

6 (behind lid) + 5

**2119600062** ST6-V2

**Accessories**

DIN-rail cover strip 24MU (RAL9010)

**2119000030** S48-9010

Earth connection blocks

**2119600003** AS16-43

PV cabinet ST3 indication stickers

**2119101012** ST3-PVBS

PV cabinet ST6 indication stickers

**2119101013** ST6-PVBS

Warning markers "LET OP kans op restspanning"

**2119100030** CHB-LETOP





**General**

The SEP PRO MK is a double-isolated, surface-mounted distribution cabinet designed for a maximum purpose of 160Amp. The cabinet comes standard with a modular frame and is typically used in industrial, commercial, utility, and luxury residential buildings. These distribution boards provide reliable and safe electrical distribution for a variety of applications.



**General parameters**

Powder coated steel housing with plastic inner covering
Double isolated
Full door with lock option

**Technical parameters**

Complies with		EN/IEC 61439-1 DIN/VDE 0660 part 600
Nominal voltage	Unom	230/440VAC
Nominal current	Inom	160A
Rated insulation voltage	AC	1000V (1500VDC)
Installation class		I
Electrical isolation class		II
Protection degree	IP	43
Material		Powder coated steel
Storage temperature		-25°C + 85°C
Operational temperature		-5°C - 55°C (with daily average <35°C)
Humidity		50...90%
Impact resistance		IK10
Installation environment		Inside installation
Installation type		Surface mounted
Entries		Top and bottom
Earth bar		Yes
Din-rail type		Frame
Rows		3, 4, 5, 6, 7
Columns		1, 2, 3, 4
Modules each row / column		12
Color housing		White (RAL9016)
Pollution degree		2

Order code

**Distribution cabinets height 3**

Surface mounted 36 modules (W=300mm, H=500mm, D=160mm)	<b>3320100013</b>	MK13N
Surface mounted 72 modules (W=550mm, H=500mm, D=160mm)	<b>3320100023</b>	MK23N
Surface mounted 108 modules (W=800mm, H=500mm, D=160mm)	<b>3320100033</b>	MK33N
Surface mounted 144 modules (W=1050mm, H=500mm, D=160mm)	<b>3320100043</b>	MK43N
Vertical shield height 500mm	<b>3320190003</b>	GTWM13

**Distribution cabinets height 4**

Surface mounted 48 modules (W=300mm, H=650mm, D=160mm)	<b>3320100014</b>	MK14N
Surface mounted 96 modules (W=550mm, H=650mm, D=160mm)	<b>3320100024</b>	MK24N
Surface mounted 144 modules (W=800mm, H=650mm, D=160mm)	<b>3320100034</b>	MK34N
Surface mounted 192 modules (W=1050mm, H=650mm, D=160mm)	<b>3320100044</b>	MK44N
Vertical shield height 650mm	<b>3320190004</b>	GTWM14

**Distribution cabinets height 5**

Surface mounted 60 modules (W=300mm, H=800mm, D=160mm)	<b>3320100015</b>	MK15N
Surface mounted 120 modules (W=550mm, H=800mm, D=160mm)	<b>3320100025</b>	MK25N
Surface mounted 180 modules (W=800mm, H=800mm, D=160mm)	<b>3320100035</b>	MK35N
Surface mounted 240 modules (W=1050mm, H=800mm, D=160mm)	<b>3320100045</b>	MK45N
Vertical shield height 800mm	<b>3320190005</b>	GTWM15

**Distribution cabinets height 6**

Surface mounted 72 modules (W=300mm, H=950mm, D=160mm)	<b>3320100016</b>	MK16N
Surface mounted 144 modules (W=550mm, H=950mm, D=160mm)	<b>3320100026</b>	MK26N
Surface mounted 216 modules (W=800mm, H=950mm, D=160mm)	<b>3320100036</b>	MK36N
Surface mounted 218 modules (W=1050mm, H=950mm, D=160mm)	<b>3320100046</b>	MK46N
Vertical shield height 950mm	<b>3320190006</b>	GTWM16

**Distribution cabinets height 7**

Surface mounted 84 modules (W=300mm, H=1100mm, D=160mm)	<b>3320100017</b>	MK17N
Surface mounted 168 modules (W=550mm, H=1100mm, D=160mm)	<b>3320100027</b>	MK27N
Surface mounted 252 modules (W=800mm, H=1100mm, D=160mm)	<b>3320100037</b>	MK37N
Surface mounted 336 modules (W=1050mm, H=1100mm, D=160mm)	<b>3320100047</b>	MK47N
Vertical shield height 1100mm	<b>3320190007</b>	GTWM17

**Accessories**

DIN-rail cover strips 24MU	<b>2119000030</b>	S48-9010
Earth / Neutral bar	<b>3320900080</b>	GPEN27
Document holder	<b>5320900100</b>	GA4F
Encoding strip (length 1 meter)	<b>5320900090</b>	GCOM1M
Adaptor lock	<b>3320900120</b>	GDV103
Euro-lock hinge	<b>3320900122</b>	GDV120N
Horizontal shield width 250mm	<b>3320191001</b>	GTWM1
Horizontal shield width 500mm	<b>3320191002</b>	GTWM2
Horizontal shield width 750mm	<b>3320191003</b>	GTWM3
Cable entry box	<b>3320900060</b>	GAG12
Cable trunk width 300mm	<b>3320900010</b>	GGRK1
Cable trunk width 550mm	<b>3320900020</b>	GGRK2
Cable trunk width 800mm	<b>3320900030</b>	GGRK3
Cable trunk width 1050mm	<b>3320900040</b>	GGRK4







## ***Modular Distribution Components***





**SL Modular switching and protection****2.03 – 2.18**

---

HS18	-	Isolator switches	2p   1MU (18mm) / 4p   1MU (18mm)	03 - 04
RCD18	-	RCCB	Type A   2p   1MU (18mm)	05 - 06
RCD36	-	RCCB	Type A   4p   1MU (36mm)	07 - 08
INS18	-	MCB	1p+n   1MU (18mm)	09 - 10
INS36	-	MCB	2p / 3p / 3p+n / 4p   1MU (18mm)	11 - 14
RCE1	-	RCBO	Type A   1p+n   1MU (18mm)	15 - 16
Busbar	-		pin-type 10mm <sup>2</sup> (9/18mm)	17 - 18

**FS Modular switching and protection****2.19 – 2.40**

---

HS1	-	Switches	1p / 2p / 3p / 4p	19 - 20
RCD1	-	RCCB	2p / 4p   Type A / Type B	21 - 26
INS1	-	MCB	1p / 1p+n / 2p / 3p / 3p+n / 4p	27 - 30
RCM	-	RCBO	1p+n / 3p+n   Type A / Type B	31 - 36
Busbar	-		Fork- and Pin type 10mm <sup>2</sup> (17.8mm)	37 - 40

**MC Modular switching and protection****2.41 – 2.45**

---

HS27	-	Switches	2p / 4p	41 - 42
RCD-B	-	RCCB	2p / 4p   Type B	43 - 44



**General**

The HS18 isolator switches are versatile switches suitable for use as a main switch in a broad range of applications. These switches are rigorously tested according to the IEC/EN60947-3 standard and meet the requirements for isolation functions. As a result, they provide reliable and safe operation for a variety of electrical distribution and control applications.

Utilization category AC-22A ensures the ability to switch mixed resistive and inductive loads with low overloads and a power factor of  $\cos \varphi = 0.65$ . (frequent operations due to subcategory A).



**General parameters**

Isolator switch AC-22A, AC-22B  
 Suitable for use in households, utilities, and industrial applications  
 Connection covers

**Electrical parameters**

Tested according		IEC/EN 60947-3
Rated operational voltage	U <sub>e</sub>	400/415 VAC
Rated frequency		50/60Hz
Poles		2p and 4p
Rated current	I <sub>n</sub>	25A,40A
Utilization category		AC-22A, AC-22B
Rated short-time withstand	I <sub>cw</sub>	480A / 1s
Rated impulse withstand	U <sub>imp</sub>	4 kV
Rated insulation voltage	U <sub>i</sub>	415V
Dielectric test voltage		2.5 kV
Mechanical life time		10.000 operation cycles
Electrical life time		4.000 operation cycles
Max. back-up fuse		50A gG
Line voltage connection		Arbitrary above or below

**Mechanical parameters**

Device width		17,8mm (2p) / 35,6mm (4p)
Device height		83mm
Device depth		77mm
Mounting		Easy fastening onto 35mm device rail (DIN)
Degree of protection (all sides)		IP40
Degree of protection (connection terminals)		IP20
Connection possibility		Cable / busbar
Terminals		Cage clamp terminal
Terminal capacity		1-16mm <sup>2</sup> (solid) 1-10mm <sup>2</sup> (cord-end)
Fastening torque of terminals		1.2 Nm
Busbar connection		Pin type
Busbar thickness		10mm <sup>2</sup>
Storage temperature		-25°C + 70°C
Ambient temperature		-5°C + 40°C (with daily average < 35°C)
Resistance to humidity and heat		Class 2
Installation class		III
Pollution degree		2
Weight		0,076 kg (2p) / 0,150 kg (4p)



	Order code	
<b>2p</b>		
In (A)		
25A	3102200025	HS18-225
40A	3102200040	HS18-240
<b>4p</b>		
In (A)		
25A	3102400025	HS18-425
40A	3102400040	HS18-440
<b>Terminal cover</b>		
Yellow		
2p	3102290010	HS18-C2
4p	3102490010	HS18-C4
<b>Marker</b>		
Yellow		
N (78x)	2119100004	CHB-N
L1 (78x)	2119100001	CHB-L1
N-L1-L2-L3 (24x)	2119100015	CHB-FDPN



**General**

The RCD18 is a modern RCCB protection device designed to meet the changing needs of modern lifestyles and technology. Its unique design, with a width of only 18mm, makes it easy to combine with other devices of similar size, such as the HS18, INS18, RCE1, and RCD36. A wide range of busbars is also available for easy device connection. The RCD18 is available in different sensitivities and amperages to accommodate various applications.



**General parameters**

High breaking capacity up to 10kA

Regular monthly testing of RCBO is legally required and the responsibility of end-users. Failure to comply may result in safety hazards.

**Electrical parameters**

Tested according		IEC/EN 61008-1
Rated operational voltage	Ue	240VAC
Minimum working voltage	Umin	>40VAC
Dependent on line voltage		Yes
Rated frequency		50/60Hz
Rated breaking capacity	Inc	10kA
Poles		2p (1p+n)
Rated current	In	25A, 40A
Residual current		10, 30, 100, 300mA
Waveform		A and AC
Time delay		Without time delay
Rated isolation voltage	Ui	500V
Rated impulse withstand voltage	Uimp	4 kV
Rated making and breaking capacity	Im	500A
Residual making and breaking capacity	Idm	500A
Electrical service life		4000 operations
Mechanical service life		4000 operations
Backup fuse for short circuit		Max. 50A gG

**Mechanical parameters**

Device width		18mm
Device height		89mm
Device depth		72mm
Mounting		Easy fastening onto 35mm device rail (DIN)
Degree of protection (all sides)		IP40
Degree of protection (connection terminals)		IP20
Connection possibility		Cable / Pin-type busbar
Terminals		Combined lift + open mouthed
Terminal capacity		1-16mm <sup>2</sup> (solid) 1-10mm <sup>2</sup> (cord-end)
Fastening torque of terminals		1.2 Nm
Busbar connection		Pin type
Busbar thickness		10mm <sup>2</sup>
Storage temperature		-25°C + 70°C
Reference temperature		30°C
Ambient temperature		-25°C + 40°C (with daily average < 35°C)
Resistance to humidity and heat		Class 2
Installation class		III
Pollution degree		2
Weight		0,115 kg

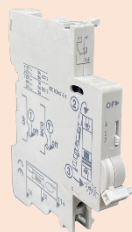

**Order code**

<b>10mA</b>		
In (A)		
25A	<b>3105101025</b>	RCD18-2501
40A	<b>3105101040</b>	RCD18-4001
<b>30mA</b>		
In (A)		
25A	<b>3105100025</b>	RCD18-2503
40A	<b>3105100040</b>	RCD18-4003
<b>100mA</b>		
In (A)		
25A	<b>3105102025</b>	RCD18-2510
40A	<b>3105102040</b>	RCD18-4010
<b>300mA</b>		
In (A)		
25A	<b>3105103025</b>	RCD18-2530
40A	<b>3105103040</b>	RCD18-4030
<b>Auxiliary contact</b>		
1 change over	<b>3104500001</b>	RCE1-AUX
		
<b>Terminal cover</b>		
Yellow		
2p	<b>3102290010</b>	HS18-C2



**General**

The RCD36 is a next-generation RCCB protection device designed for modern lifestyles and high-tech developments. It has a unique width of 36mm and can be easily combined with other devices of similar size, such as HS18, INS18, RCE1, and RCD18. A range of busbars are available to connect these devices together. The RCD36 is available in different sensitivities and amperages to suit various applications.



**General parameters**

- High breaking capacity up to 10kA
- With handle lock, protective cover and seal function, to protect for error operation
- Regular monthly testing of RCBO is legally required and the responsibility of end-users. Failure to comply may result in safety hazards.

**Electrical parameters**

Tested according		IEC/EN 61008-1
Rated operational voltage	Ue	400/415VAC
Dependent on line voltage		No
Rated frequency		50/60Hz
Rated breaking capacity	Inc	10kA
Poles		4p (3p+n)
Rated current	In	25A, 40A
Residual current		30, 100, 300mA
Waveform		A and AC
Time delay		Without time delay
Rated isolation voltage	Ui	500V
Rated impulse withstand voltage	Uimp	4 kV
Rated making and breaking capacity	Im	1000A
Residual making and breaking capacity	Idm	1000A
Electrical service life		4000 operations
Mechanical service life		4000 operations
Backup fuse for short circuit		Max. 63A gG

**Mechanical parameters**

Device width		36mm
Device height		89mm
Device depth		69mm
Mounting		Easy fastening onto 35mm device rail (DIN)
Degree of protection (all sides)		IP40
Degree of protection (connection terminals)		IP20
Connection possibility		Cable / Pin-type busbar
Terminals		Combined lift + open mouthed
Terminal capacity		1-16mm <sup>2</sup> (solid) 1-10mm <sup>2</sup> (cord-end)
Fastening torque of terminals		1.2 Nm
Busbar connection		Pin type
Busbar thickness		10mm <sup>2</sup>
Storage temperature		-25°C + 70°C
Reference temperature		30°C
Ambient temperature		-25°C + 40°C (with daily average < 35°C)
Resistance to humidity and heat		Class 2
Installation class		III
Pollution degree		2
Weight		0,21 kg



	Order code	
<b>30mA</b>		
In (A)		
25A	3105200025	RCD36-25030
40A	3105200040	RCD36-40030
<b>100mA</b>		
In (A)		
25A	3105202025	RCD36-25100
40A	3105202040	RCD36-40100
<b>300mA</b>		
In (A)		
25A	3105203025	RCD36-25300
40A	3105203040	RCD36-40300
<b>Auxiliary contact</b>		
1 change over	3105300001	RCD-AUX



**INS18 – MCB - 1p+n**



**General**

INS18 miniature circuit breakers are suitable for domestic, utility, and industrial applications. They can be combined with up to three signal contacts. The INS18's design is based on a similar size as HS18, RCD18, RCE1, and RCD36, making it easy to combine them together. A wide range of busbars is also available to connect these items to each other. The INS18 is available in different sensitivities and amperages to suit various applications.



**General parameters**

High limiting on short circuit current  
Suitable for use in households, utilities, and industrial applications  
Accessoires

**Electrical parameters**

Tested according		IEC/EN 60898
Rated operational voltage	Ue	230 VAC
Maximum working voltage	Umax	254 VAC
Minimum working voltage	Umin	12V AC/DC
Rated frequency		50/60Hz
Rated short-circuit capacity	Icn	6kA
Rated making and breaking capacity	Icn1	6kA
Poles		1p+n and 2p+2n
Protected poles		1
Switching neutral pole		Yes
Rated current	In	1, 2, 3, 4, 6, 8, 10, 13, 16, 20, 25, 32, 40A
Tripping characteristics		B, C
Rated impulse withstand	Uimp	4 kV
Rated insulation voltage	Ui	500V
Transient overvoltage category		3
Selectivity class		3
Energy limiting class		3
Dielectric test voltage		2 kV (1min)
Mechanical life time		10 000 operation cycles
Electrical life time		4 000 operation cycles
Max. back-up fuse		Max. 125A gG
Line voltage connection		Arbitrary above or below

**Mechanical parameters**

Device width		18mm
Device height		89mm
Device depth		69mm
Mounting		Easy fastening onto 35mm device rail (DIN)
Degree of protection (all sides)		IP40
Degree of protection (connection terminals)		IP20
Connection possibility		Cable / Pin-type busbar
Terminals		Combined lift + open mouthed
Terminal capacity		1-16mm <sup>2</sup> (solid) 1-10mm <sup>2</sup> (cord-end)
Fastening torque of terminals		1.2 Nm
Busbar connection		Pin type
Busbar thickness		10mm <sup>2</sup>
Storage temperature		-25°C + 70°C
Reference temperature		30°C
Ambient temperature		-25°C + 40°C (with daily average < 35°C)
Resistance to humidity and heat		Class 2
Installation class		III
Pollution degree		2
Weight		0,21 kg



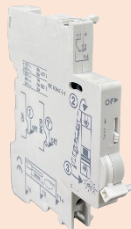

**Order code**

1p+n In(A)	Curve B		Curve C	
	1	<b>3101541001</b>	INS18-1NB01	<b>3101551001</b>
2	<b>3101541002</b>	INS18-1NB02	<b>3101551002</b>	INS18-1NC02
3	<b>3101541003</b>	INS18-1NB03	<b>3101551003</b>	INS18-1NC03
4	<b>3101541004</b>	INS18-1NB04	<b>3101551004</b>	INS18-1NC04
6	<b>3101541006</b>	INS18-1NB06	<b>3101551006</b>	INS18-1NC06
8	<b>3101541008</b>	INS18-1NB08	<b>3101551008</b>	INS18-1NC08
10	<b>3101541010</b>	INS18-1NB10	<b>3101551010</b>	INS18-1NC10
13	<b>3101541013</b>	INS18-1NB13	<b>3101551013</b>	INS18-1NC13
16	<b>3101541016</b>	INS18-1NB16	<b>3101551016</b>	INS18-1NC16
20	<b>3101541020</b>	INS18-1NB20	<b>3101551020</b>	INS18-1NC20
25	<b>3101541025</b>	INS18-1NB25	<b>3101551025</b>	INS18-1NC25
32	<b>3101541032</b>	INS18-1NB32	<b>3101551032</b>	INS18-1NC32
40	<b>3101541040</b>	INS18-1NB40	<b>3101551040</b>	INS18-1NC40
<b>2p+2n</b>				
In(A)				
16	<b>3101541116</b>	INS18-2NB16	<b>3101551116</b>	INS18-2NC16
20	<b>3101541120</b>	INS18-2NB20	<b>3101551120</b>	INS18-2NC20
25	<b>3101541125</b>	INS18-2NB25	<b>3101551125</b>	INS18-2NC25
<b>Auxiliary contact</b>				
1 change over	<b>3104500001</b>	RCE1-AUX		
<b>Terminal covers</b>				
Yellow				
2p	<b>3102290010</b>	HS18-C2		
4p	<b>3102490010</b>	HS18-C4		



**General**

INS18 miniature circuit breakers are suitable for domestic, utility, and industrial applications. They can be combined with up to three signal contacts. The INS18's design is based on a similar size as HS18, RCD18, RCE1, and RCD36, making it easy to combine them together. A wide range of busbars is also available to connect these items to each other. The INS18 is available in different sensitivities and amperages to suit various applications.



**General parameters**

High limiting on short circuit current  
 Suitable for use in households, utilities, and industrial applications  
 Accessoires

**Electrical parameters**

Tested according		IEC/EN 60898
Rated operational voltage	Ue	400/415VAC
Minimum working voltage	Umin	12V AC/DC
Rated frequency		50/60Hz
Rated short-circuit capacity	Icn	6kA
Rated making and breaking capacity	Icn1	6kA
Poles		2p, 3p, 3p+n and 4p
Protected poles		2, 3, 4
Rated current	In	1, 2, 3, 4, 6, 8, 10, 13, 16, 20, 25, 32, 40A
Tripping characteristics		B, C, D
Rated impulse withstand	Uimp	4 kV
Rated insulation voltage	Ui	500V
Transient overvoltage category		3
Selectivity class		3
Energy limiting class		3
Dielectric test voltage		2 kV (1min)
Mechanical life time		10 000 operation cycles
Electrical life time		4 000 operation cycles
Max. back-up fuse		Max. 125A gG
Line voltage connection		Arbitrary above or below

**Mechanical parameters**

Device width		36mm
Device height		89mm
Device depth		69mm
Mounting		Easy fastening onto 35mm device rail (DIN)
Degree of protection (all sides)		IP40
Degree of protection (connection terminals)		IP20
Connection possibility		Cable / Pin-type busbar
Terminals		Combined lift + open mouthed
Terminal capacity		1-16mm <sup>2</sup> (solid) 1-10mm <sup>2</sup> (cord-end)
Fastening torque of terminals		1.2 Nm
Busbar connection		Pin type
Busbar thickness		10mm <sup>2</sup>
Storage temperature		-25°C + 70°C
Reference temperature		30°C
Ambient temperature		-25°C + 40°C (with daily average < 35°C)
Resistance to humidity and heat		Class 2
Installation class		III
Pollution degree		2
Weight		0,126 kg (2p)    0,210kg (3p) 0,230 kg (3p+n)    0,242 kg (4p)

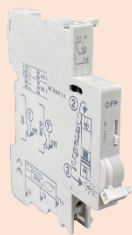

**Order code**

2p In(A)	Curve B		Curve C		Curve D	
	1	3101642001	INS36-2B01	3101652001	INS36-2C01	3101662001
2	3101642002	INS36-2B02	3101652002	INS36-2C02	3101662002	INS36-2D02
3	3101642003	INS36-2B03	3101652003	INS36-2C03	3101662003	INS36-2D03
4	3101642004	INS36-2B04	3101652004	INS36-2C04	3101662004	INS36-2D04
6	<b>3101642006</b>	INS36-2B06	<b>3101652006</b>	INS36-2C06	<b>3101662006</b>	INS36-2D06
8	3101642008	INS36-2B08	3101652008	INS36-2C08	3101662008	INS36-2D08
10	<b>3101642010</b>	INS36-2B10	<b>3101652010</b>	INS36-2C10	<b>3101662010</b>	INS36-2D10
13	<b>3101642013</b>	INS36-2B13	<b>3101652013</b>	INS36-2C13	<b>3101662013</b>	INS36-2D13
16	<b>3101642016</b>	INS36-2B16	<b>3101652016</b>	INS36-2C16	<b>3101662016</b>	INS36-2D16
20	<b>3101642020</b>	INS36-2B20	<b>3101652020</b>	INS36-2C20	<b>3101662020</b>	INS36-2D20
25	<b>3101642025</b>	INS36-2B25	<b>3101652025</b>	INS36-2C25	<b>3101662025</b>	INS36-2D25
32	<b>3101642032</b>	INS36-2B32	<b>3101652032</b>	INS36-2C32	<b>3101662032</b>	INS36-2D32
40	<b>3101642040</b>	INS36-2B40	<b>3101652040</b>	INS36-2C40	<b>3101662040</b>	INS36-2D40
<b>3p</b>						
In(A)						
1	3101645001	INS36-4B01	3101655001	INS36-4C01	3101665001	INS36-4D01
2	3101645002	INS36-4B02	3101655002	INS36-4C02	3101665002	INS36-4D02
3	3101645003	INS36-4B03	3101655003	INS36-4C03	3101665003	INS36-4D03
4	3101645004	INS36-4B04	3101655004	INS36-4C04	3101665004	INS36-4D04
6	<b>3101645006</b>	INS36-4B06	<b>3101655006</b>	INS36-4C06	<b>3101665006</b>	INS36-4D06
8	3101645008	INS36-4B08	3101655008	INS36-4C08	3101665008	INS36-4D08
10	<b>3101645010</b>	INS36-4B10	<b>3101655010</b>	INS36-4C10	<b>3101665010</b>	INS36-4D10
13	<b>3101645013</b>	INS36-4B13	<b>3101655013</b>	INS36-4C13	<b>3101665013</b>	INS36-4D13
16	<b>3101645016</b>	INS36-4B16	<b>3101655016</b>	INS36-4C16	<b>3101665016</b>	INS36-4D16
20	<b>3101645020</b>	INS36-4B20	<b>3101655020</b>	INS36-4C20	<b>3101665020</b>	INS36-4D20
25	<b>3101645025</b>	INS36-4B25	<b>3101655025</b>	INS36-4C25	<b>3101665025</b>	INS36-4D25
32	<b>3101645032</b>	INS36-4B32	<b>3101655032</b>	INS36-4C32	<b>3101665032</b>	INS36-4D32
40	<b>3101645040</b>	INS36-4B40	<b>3101655040</b>	INS36-4C40	<b>3101665040</b>	INS36-4D40
<b>Auxiliary contact</b>						
1 change over	<b>3104500001</b>	RCE1-AUX				
						
<b>Terminal covers</b>						
Yellow						
2p	<b>3102290010</b>	HS18-C2				
4p	<b>3102490010</b>	HS18-C4				

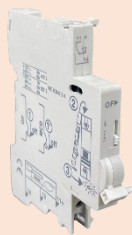

**Order code**

3p+n In(A)	Curve B		Curve C		Curve D	
	1	3101643001	INS36-3NB01	3101653001	INS36-3NC01	3101663001
2	3101643002	INS36-3NB02	3101653002	INS36-3NC02	3101663002	INS36-3ND02
3	3101643003	INS36-3NB03	3101653003	INS36-3NC03	3101663003	INS36-3ND03
4	3101643004	INS36-3NB04	3101653004	INS36-3NC04	3101663004	INS36-3ND04
6	<b>3101643006</b>	INS36-3NB06	<b>3101653006</b>	INS36-3NC06	<b>3101663006</b>	INS36-3ND06
8	3101643008	INS36-3NB08	3101653008	INS36-3NC08	3101663008	INS36-3ND08
10	<b>3101643010</b>	INS36-3NB10	<b>3101653010</b>	INS36-3NC10	<b>3101663010</b>	INS36-3ND10
13	<b>3101643013</b>	INS36-3NB13	<b>3101653013</b>	INS36-3NC13	<b>3101663013</b>	INS36-3ND13
16	<b>3101643016</b>	INS36-3NB16	<b>3101653016</b>	INS36-3NC16	<b>3101663016</b>	INS36-3ND16
20	<b>3101643020</b>	INS36-3NB20	<b>3101653020</b>	INS36-3NC20	<b>3101663020</b>	INS36-3ND20
25	<b>3101643025</b>	INS36-3NB25	<b>3101653025</b>	INS36-3NC25	<b>3101663025</b>	INS36-3ND25
32	<b>3101643032</b>	INS36-3NB32	<b>3101653032</b>	INS36-3NC32	<b>3101663032</b>	INS36-3ND32
40	<b>3101643040</b>	INS36-3NB40	<b>3101653040</b>	INS36-3NC40	<b>3101663040</b>	INS36-3ND40
<b>4p</b>						
In(A)						
1	3101644001	INS36-4B01	3101654001	INS36-4C01	3101664001	INS36-4D01
2	3101644002	INS36-4B02	3101654002	INS36-4C02	3101664002	INS36-4D02
3	3101644003	INS36-4B03	3101654003	INS36-4C03	3101664003	INS36-4D03
4	3101644004	INS36-4B04	3101654004	INS36-4C04	3101664004	INS36-4D04
6	<b>3101644006</b>	INS36-4B06	<b>3101654006</b>	INS36-4C06	<b>3101664006</b>	INS36-4D06
8	3101644008	INS36-4B08	3101654008	INS36-4C08	3101664008	INS36-4D08
10	<b>3101644010</b>	INS36-4B10	<b>3101654010</b>	INS36-4C10	<b>3101664010</b>	INS36-4D10
13	<b>3101644013</b>	INS36-4B13	<b>3101654013</b>	INS36-4C13	<b>3101664013</b>	INS36-4D13
16	<b>3101644016</b>	INS36-4B16	<b>3101654016</b>	INS36-4C16	<b>3101664016</b>	INS36-4D16
20	<b>3101644020</b>	INS36-4B20	<b>3101654020</b>	INS36-4C20	<b>3101664020</b>	INS36-4D20
25	<b>3101644025</b>	INS36-4B25	<b>3101654025</b>	INS36-4C25	<b>3101664025</b>	INS36-4D25
32	<b>3101644032</b>	INS36-4B32	<b>3101654032</b>	INS36-4C32	<b>3101664032</b>	INS36-4D32
40	<b>3101644040</b>	INS36-4B40	<b>3101654040</b>	INS36-4C40	<b>3101664040</b>	INS36-4D40
<b>Auxiliary contact</b>						
1 change over	<b>3104500001</b>	RCE1-AUX				
						
<b>Terminal cover</b>						
Yellow	<b>3102490010</b>	HS18-C4				



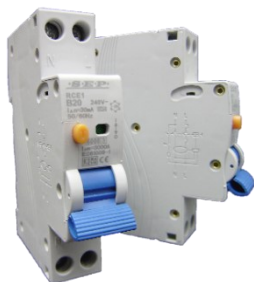

**General**

The SEP RCE1 RCBO is a protective device against residual current, short-circuit and overload. It is mainly used to protect against electrical shock and fire disaster caused by damaged equipment. Suitable for AC circuits of 50/60Hz, rated voltage of 230V and current up to 40A. Commonly used in domestic, utility and industrial applications.



**General parameters**

High limiting on short circuit current  
Regular monthly testing of RCBO is legally required and the responsibility of end-users. Failure to comply may result in safety hazards.

**Electrical parameters**

Tested according		IEC/EN 61009
Rated operational voltage	Ue	230 VAC
Minimum working voltage	Umin	>40VAC
Depended on line voltage		Yes
Rated frequency		50/60Hz
Rated short-circuit capacity	Icn	6kA
Rated making and breaking capacity	Icn1	6kA
Poles		1p+n and 2p+2n
Protected poles		1
Switching neutral pole		Yes
Rated current	In	6, 10, 16, 20, 25, 32, 40A
Residual current		10mA, 30mA, 100mA, 300mA
Waveform		A type (residual AC and pulsating DC current)
Tripping characteristics		B, C
Energy limiting class		3
Transient overvoltage category		3
Rated isolation voltage	Ui	500V
Rated impulse withstand voltage	Uimp	4 kV
Dielectric test voltage		2 kV
Electrical service life		10 000 operations
Mechanical service life		4 000 operations
Backup fuse for short circuit		Max. 125A gG
Mechanical service life		Arbitrary – above or below

**Mechanical parameters**

Device width		18mm
Device height		89mm
Device depth		69mm
Mounting		Easy fastening onto 35mm device rail (DIN)
Degree of protection (all sides)		IP40
Degree of protection (connection terminals)		IP20
Connection possibility		Cable / Pin-type busbar
Terminals		Combined lift + open mouthed
Terminal capacity		1-16mm <sup>2</sup> (solid) 1-10mm <sup>2</sup> (cord-end)
Fastening torque of terminals		1.2 Nm
Busbar connection		Pin type
Busbar thickness		10mm <sup>2</sup>
Storage temperature		-25°C + 70°C
Ambient temperature		-5°C + 40°C (with daily average < 35°C)
Resistance to humidity and heat		Class 2
Installation class		III
Pollution degree		2
Weight		0,122 kg

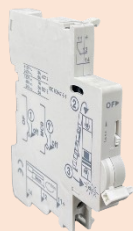

10mA In(A)	Order code			
	Curve B		Curve C	
6	<b>3104510106</b>	RCE1-B06.01	<b>3104520106</b>	RCE1-C06.01
10	<b>3104510110</b>	RCE1-B10.01	<b>3104520110</b>	RCE1-C10.01
13	<b>3104510116</b>	RCE1-B16.01	<b>3104520116</b>	RCE1-C16.01
16	<b>3104510120</b>	RCE1-B20.01	<b>3104520120</b>	RCE1-C20.01
20	<b>3104510125</b>	RCE1-B25.01	<b>3104520125</b>	RCE1-C25.01
25	<b>3104510132</b>	RCE1-B32.01	<b>3104520132</b>	RCE1-C32.01
32	<b>3104510140</b>	RCE1-B40.01	<b>3104520140</b>	RCE1-C40.01
40	<b>3104510106</b>	RCE1-B06.01	<b>3104520106</b>	RCE1-C06.01
<b>30mA</b>				
In(A)				
6	<b>3104510006</b>	RCE1-B06.03	<b>3104520006</b>	RCE1-C06.03
10	<b>3104510010</b>	RCE1-B10.03	<b>3104520010</b>	RCE1-C10.03
13	<b>3104510016</b>	RCE1-B16.03	<b>3104520016</b>	RCE1-C16.03
16	<b>3104510020</b>	RCE1-B20.03	<b>3104520020</b>	RCE1-C20.03
20	<b>3104510025</b>	RCE1-B25.03	<b>3104520025</b>	RCE1-C25.03
25	<b>3104510032</b>	RCE1-B32.03	<b>3104520032</b>	RCE1-C32.03
32	<b>3104510040</b>	RCE1-B40.03	<b>3104520040</b>	RCE1-C40.03
40	<b>3104510006</b>	RCE1-B06.03	<b>3104520006</b>	RCE1-C06.03
<b>100mA</b>				
In(A)				
6	<b>3104510206</b>	RCE1-B06.10	<b>3104520206</b>	RCE1-C06.10
10	<b>3104510210</b>	RCE1-B10.10	<b>3104520210</b>	RCE1-C10.10
13	<b>3104510216</b>	RCE1-B16.10	<b>3104520216</b>	RCE1-C16.10
16	<b>3104510220</b>	RCE1-B20.10	<b>3104520220</b>	RCE1-C20.10
20	<b>3104510225</b>	RCE1-B25.10	<b>3104520225</b>	RCE1-C25.10
25	<b>3104510232</b>	RCE1-B32.10	<b>3104520232</b>	RCE1-C32.10
32	<b>3104510240</b>	RCE1-B40.10	<b>3104520240</b>	RCE1-C40.10
40	<b>3104510206</b>	RCE1-B06.10	<b>3104520206</b>	RCE1-C06.10
<b>300mA</b>				
In(A)				
6	<b>3104510306</b>	RCE1-B06.03	<b>3104520306</b>	RCE1-C06.03
10	<b>3104510310</b>	RCE1-B10.03	<b>3104520310</b>	RCE1-C10.03
13	<b>3104510316</b>	RCE1-B16.03	<b>3104520316</b>	RCE1-C16.03
16	<b>3104510320</b>	RCE1-B20.03	<b>3104520320</b>	RCE1-C20.03
20	<b>3104510325</b>	RCE1-B25.03	<b>3104520325</b>	RCE1-C25.03
25	<b>3104510332</b>	RCE1-B32.03	<b>3104520332</b>	RCE1-C32.03
32	<b>3104510340</b>	RCE1-B40.03	<b>3104520340</b>	RCE1-C40.03
40	<b>3104510306</b>	RCE1-B06.03	<b>3104520306</b>	RCE1-C06.03
<b>2p+2n – 30mA</b>				
In(A)				
16	<b>3104511016</b>	RCE1-2N-B16	<b>3105421016</b>	RCE1-2N-C16
20	<b>3104511020</b>	RCE1-2N-B20	<b>3105421020</b>	RCE1-2N-C20
25	<b>3104511025</b>	RCE1-2N-B25	<b>3105421025</b>	RCE1-2N-C25
<b>Auxiliary contact</b>				
1 change over	<b>3104500001</b>	RCE1-AUX		
<b>Terminal cover</b>				
Yellow				
2p	<b>3102290010</b>	HS18-C2		
4p	<b>3102490010</b>	HS18-C4		

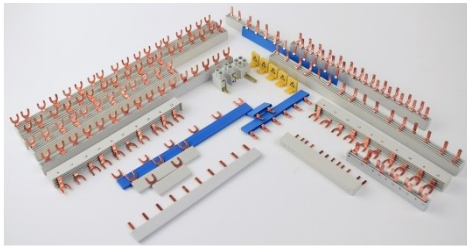

**General**

The SEP insulated busbar system is a modular interconnection solution that facilitates the connection of various components in a cabinet. The use of insulated busbars improves the reliability of connections, reduces the probability of failures and enhances heat management within the cabinet. The system is complemented by a range of accessories, which enable significant reduction of internal wiring, resulting in a more organized and neat cabinet.



**General parameters**

Insulated busbar
No cutting is necessary as the material is already at the required length
Wide range of busbar
Wide range of connection accessories

**Technical parameters**

Complies with	IEC 60439-1   2000-08
According	IEC 664
Busbar material	E-Cu-ETP
Isolation material	Ultramid PA6 glass fiber reinforced
Form test	125°C (after 1,8MPa)
Glow wire test	960°C according IEC60895-2-12
Flammability class	V0
Tracking index	550
Short circuit strength	25kA / 100A gl
Disruptive strength	36kV / mm
Climate stability	IEC 68-2
Operating voltage	500V AC
Surge voltage	4kV
Isolation group	According VDE 0110-T1
Overtoltage category	III
Degree of soiling	2
Halogen free	According DIN EN 50267-2-2
Colors	Related to RAL7035 and RAL5015 (grey/blue)
Type	PIN and FORK
Cross section	10mm <sup>2</sup>
Max. current one side line-in	63A
Max. current central line-in	100A*

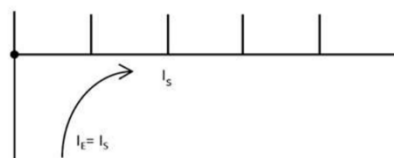

ONE SIDE LINE-IN

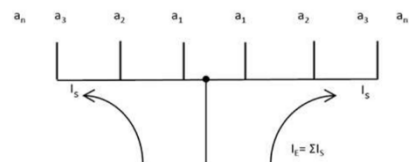

CENTRAL LINE-IN

\* The  $I_s$  is rated on an equal divided demand on both sides of the feeding-main (line-in) of the busbar the sum of the equal divided output current cannot be higher than the busbar current ( $I_s$ )



Order code

**1 Phase Busbar (N) – offset 4mm**

number of poles

2	2x 1p	(2MU)	17,8mm	Blue	<b>2305101992</b>	P01002B10
3	3x 1p	(3MU)	17,8mm	Blue	<b>2305101993</b>	P01003B10
4	4x 1p	(4MU)	17,8mm	Blue	<b>2305101994</b>	P01004B10
5	5x 1p	(5MU)	17,8mm	Blue	<b>2305101995</b>	P01005B10
6	6x 1p	(6MU)	17,8mm	Blue	<b>2305101996</b>	P01006B10
8	8x 1p	(8MU)	17,8mm	Blue	<b>2305101998</b>	P01008B10
10	10x 1p	(10MU)	17,8mm	Blue	<b>2305101990</b>	P01010B10
12	12x 1p	(12MU)	17,8mm	Blue	<b>2305101991</b>	P01012B10

**2 Phase Busbar (N-L-N-L-...)**

number of poles

6	3x 2p	(3MU)	9/18mm		<b>2305122906</b>	P02006G20
8	4x 2p	(4MU)	9/18mm		<b>2305122908</b>	P02008G20
10	5x 2p	(5MU)	9/18mm		<b>2305122910</b>	P02010G20
12	6x 2p	(6MU)	9/18mm		<b>2305122912</b>	P02012G20
16	8x 2p	(8MU)	9/18mm		<b>2305122916</b>	P02016G20
20	10x 2p	(10MU)	9/18mm		<b>2305122920</b>	P02020G20
24	12x 2p	(12MU)	9/18mm		<b>2350122924</b>	P02024G20

**3 Phase + N Busbar (N-L1-N-L2-N-L3-...)**

number of poles

12	6x 2p	(6MU)	9/18mm		<b>P04012G20</b>	P04012G20
18	9x 2p	(9MU)	9/18mm		<b>P04018G20</b>	P04018G20
24	12x 2p	(12MU)	9/18mm		<b>P04024G20</b>	P04024G20

**4 Phase Busbar (N-L1-L2-L3-....)**

number of poles

8	2x 4p	(4MU)	9/18mm		<b>2305142808</b>	P04008G40
12	3x 4p	(6MU)	9/18mm		<b>2305142812</b>	P04012G40
16	4x 4p	(8MU)	9/18mm		<b>2305142816</b>	P04016G40
20	5x 4p	(10MU)	9/18mm		<b>2305142820</b>	P04020G40
24	6x 4p	(12MU)	9/18mm		<b>2305142824</b>	P04024G40

**Combination busbar (N-L1-L2-L3-N-L1-N-L2-N-L3)**

Number of poles

10	1x 4p + 3x 2p	(5MU)	9/18mm		<b>2305195910</b>	P24010G20
----	---------------	-------	--------	--	-------------------	-----------

**Combination busbar (N-L1-L2-L3-N-L1-N-L2-N-L3-N-L1)**

Number of poles

12	1x 4p + 4x 2p	(6MU)	9/18mm		<b>2305195910</b>	P14012G40
----	---------------	-------	--------	--	-------------------	-----------

**Accessoires busbar**

Busbar cover pin-type 9/18mm				<b>2115900015</b>	IK-D
Double connection 2x10mm <sup>2</sup> terminal high - grey				<b>2115900040</b>	DTH
Double connection 2x10mm <sup>2</sup> terminal low - grey				<b>2115900041</b>	DTL
Double connection 2x10mm <sup>2</sup> terminal high - blue				<b>2115900540</b>	DTH-B
Double connection 2x10mm <sup>2</sup> terminal low - blue				<b>2115900541</b>	DTL-B

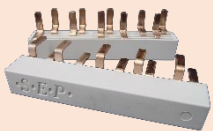
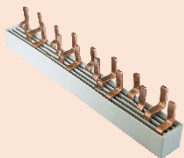
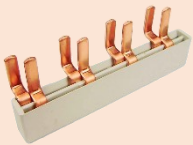
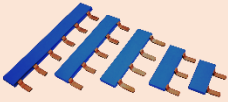



#### General

The HS1 isolator switches comply with the IEC/EN60947-3 standard and meet isolation function requirements. They can function as a main switch and are suitable for a wide range of applications. The switches are designed to work with AC-21A/B, AC-22A/B, AC-23/AB for resistive, inductive and highly inductive loads. Additionally, they can be used in DC applications with utilization category DC-22 and DC-23.



#### General parameters

Isolator switch AC-21 A/B, AC-22 A/B, AC-23 A/B, DC-22 and DC-23  
Suitable for use in households, utilities, and industrial applications  
Including connection covers

#### Electrical parameters

Tested according		IEC/EN 60947-3
Rated operational voltage	U <sub>e</sub>	400/415 VAC
Rated frequency		50/60Hz
Poles		1, 2, 3, 4p
Rated current	I <sub>n</sub>	25A, 40A, 63A, 80A, 100A, 125A, 160A
Utilization category		AC-21A/B, AC-22A/B, AC-23A/B, DC-22, DC-23
Rated short-time withstand	I <sub>cw</sub>	5.5kA / 1s
Rated short-time making capacity	I <sub>cm</sub>	20kA
Rated impulse withstand	U <sub>imp</sub>	8 kV
Rated insulation voltage	U <sub>i</sub>	750V
Dielectric test voltage		2.5 kV
Mechanical life time		10.000 operation cycles
Electrical life time		4.000 operation cycles
Max. back-up fuse		160A gG
Line voltage connection		Arbitrary above or below

#### Mechanical parameters

Device width		17,8mm (each pole)
Device height		83mm
Device depth		77mm
Mounting		Easy fastening onto 35mm device rail (DIN)
Degree of protection (all sides)		IP40
Degree of protection (connection terminals)		IP20
Connection possibility		Cable / busbar
Terminals		Cage clamp terminal
Terminal capacity		1-50mm <sup>2</sup> (solid) 1-35mm <sup>2</sup> (cord-end)
Fastening torque of terminals		3.5 Nm
Busbar connection		Fork / Pin type
Busbar thickness		30mm <sup>2</sup>
Storage temperature		-25°C + 70°C
Ambient temperature		-5°C + 40°C (with daily average < 35°C)
Resistance to humidity and heat		Class 2
Installation class		III
Pollution degree		2
Weight		0,15 kg (each pole)



	Order code	
<b>1p</b>		
In (A)		
25A	3110000010	HS1-1025
40A	3110000020	HS1-1040
63A	3110000030	HS1-1063
80A	3110000040	HS1-1080
100A	3110000050	HS1-1100
125A	3110000060	HS1-1125
160A	3110000070	HS1-1160
<b>2p</b>		
In (A)		
25A	3110000080	HS1-2025
40A	3110000090	HS1-2040
63A	3110000100	HS1-2063
80A	3110000110	HS1-2080
100A	3110000120	HS1-2100
125A	3110000130	HS1-2125
160A	3110000140	HS1-2160
<b>3p</b>		
In (A)		
25A	3110000150	HS1-3025
40A	3110000160	HS1-3040
63A	3110000170	HS1-3063
80A	3110000180	HS1-3080
100A	3110000190	HS1-3100
125A	3110000200	HS1-3125
160A	3110000210	HS1-3160
<b>4p</b>		
In (A)		
25A	3110000220	HS1-4025
40A	3110000230	HS1-4040
63A	3110000240	HS1-4063
80A	3110000250	HS1-4080
100A	3110000260	HS1-4100
125A	3110000270	HS1-4125
160A	3110000280	HS1-4160
<b>Markers</b>		
Yellow		
N (78x)	2119100004	CHB-N
L1 (78x)	2119100001	CHB-L1
L2 (78)x	2119100002	CHB-L2
L3 (78x)	2119100003	CHB-L3
N-L1-L2-L3 (40x)	2119100010	CHB-NLP



### General

The RCD1 provides diverse RCCB protection devices for different situations. It covers solutions up to 125A in various categories, making it suitable for our changing lifestyle and high-tech developments.



### General parameters

- High breaking capacity up to 10kA
- With handle lock, protective cover and seal function, to protect for error operation
- Regular monthly testing of RCBO is legally required and the responsibility of end-users. Failure to comply may result in safety hazards.

### Electrical parameters

Tested according		IEC/EN 61008-1
Rated operational voltage	U <sub>e</sub>	240/415VAC
Dependent on line voltage		No
Rated frequency		50/60Hz
Rated breaking capacity	I <sub>nc</sub>	10kA
Poles		2p (1p+n) / 4p (3p+n)
Rated current	I <sub>n</sub>	16A, 25A, 40A, 63A, 80A, 100A, 125A
Residual current		10, 30, 100, 300, 500mA
Waveform		A (including AC)
Time delay		Without time delay
	[G]	Short term delayed (10ms)
	[S]	Selective type
Rated isolation voltage	U <sub>i</sub>	500V
Rated impulse withstand voltage	U <sub>imp</sub>	6 kV
Rated making and breaking capacity	I <sub>m</sub>	3000A
Residual making and breaking capacity	I <sub>dm</sub>	3000A
Electrical service life		4000 operations
Mechanical service life		20000 operations
Backup fuse for short circuit		Max. 125A gG
Line voltage connection		Arbitrary (above or below)

### Mechanical parameters

Device width		36mm (2 pole) / 72mm (4 pole)
Device height		90mm
Device depth		72mm
Mounting		Easy fastening onto 35mm device rail (DIN)
Degree of protection (all sides)		IP40
Terminals		Combined lift + open mouthed
Terminal capacity		4-50mm <sup>2</sup> (solid) 4-35mm <sup>2</sup> (cord-end)
Fastening torque of terminals		3.5Nm
Busbar connection		Fork/Pin type
Busbar thickness		10mm <sup>2</sup> , 16mm <sup>2</sup> , 30mm <sup>2</sup>
Storage temperature		-25°C + 70°C
Reference temperature		30°C
Ambient temperature		-25°C + 40°C (with daily average < 35°C)
Resistance to humidity and heat		Class 2
Installation class		III
Pollution degree		2
Weight		0,28 kg (2-pole), 0,44 kg (4-pole)



		Order code			
Type A		2 pole		4 pole	
In (A)	Sensitivity				
16A	10mA	3112000010	RCD1-2A-01601		
25A	10mA	3112000030	RCD1-2A-02501		
40A	10mA	3112000070	RCD1-2A-04001		
<b>Type A</b>					
In (A)	Sensitivity				
16A	30mA	3112000020	RCD1-2A-01603		
25A	30mA	3112000040	RCD1-2A-02503	3112000330	RCD1-4A-02503
40A	30mA	3112000080	RCD1-2A-04003	3112000390	RCD1-4A-04003
63A	30mA	3112000130	RCD1-2A-06303	3112000460	RCD1-4A-06303
80A	30mA	3112000180	RCD1-2A-08003	3112000530	RCD1-4A-08003
100A	30mA	3112000230	RCD1-2A-10003	3112000600	RCD1-4A-10003
125A	30mA	3112000280	RCD1-2A-12503	3112000670	RCD1-4A-12503
<b>Type A</b>					
In (A)	Sensitivity				
25A	100mA	3112000050	RCD1-2A-02510	3112000340	RCD1-4A-02510
40A	100mA	3112000090	RCD1-2A-04010	3112000400	RCD1-4A-04010
63A	100mA	3112000140	RCD1-2A-06310	3112000470	RCD1-4A-06310
80A	100mA	3112000190	RCD1-2A-08010	3112000540	RCD1-4A-08010
100A	100mA	3112000240	RCD1-2A-10010	3112000610	RCD1-4A-10010
125A	100mA	3112000290	RCD1-2A-12510	3112000680	RCD1-4A-12510
<b>Type A</b>					
In (A)	Sensitivity				
25A	300mA	3112000060	RCD1-2A-02530	3112000350	RCD1-4A-02530
40A	300mA	3112000100	RCD1-2A-04030	3112000410	RCD1-4A-04030
63A	300mA	3112000150	RCD1-2A-06330	3112000480	RCD1-4A-06330
80A	300mA	3112000200	RCD1-2A-08030	3112000550	RCD1-4A-08030
100A	300mA	3112000250	RCD1-2A-10030	3112000620	RCD1-4A-10030
125A	300mA	3112000300	RCD1-2A-12530	3112000690	RCD1-4A-12530
<b>Type A</b>					
In (A)	Sensitivity				
25A	500mA			3112000360	RCD1-4A-02550
40A	500mA			3112000420	RCD1-4A-04050
63A	500mA			3112000490	RCD1-4A-06350
80A	500mA			3112000560	RCD1-4A-08050
100A	500mA			3112000630	RCD1-4A-10050
125A	500mA			3112000700	RCD1-4A-12550
<b>Auxiliary contact</b>					
1 change over		3105300001	RCD-AUX	3105300001	RCD-AUX





Order code

Type A[G]		Order code			
In (A)	Sensitivity	2 pole		4 pole	
16A	10mA	<b>3112000740</b>	RCD1-2A-01601G		
25A	10mA	<b>3112000760</b>	RCD1-2A-02501G		
40A	10mA	<b>3112000800</b>	RCD1-2A-04001G		
<b>Type A[G]</b>					
In (A)	Sensitivity	2 pole		4 pole	
16A	30mA	<b>3112000750</b>	RCD1-2A-01603G		
25A	30mA	<b>3112000770</b>	RCD1-2A-02503G	<b>3112000960</b>	RCD1-4A-02503G
40A	30mA	<b>3112000810</b>	RCD1-2A-04003G	<b>3112001000</b>	RCD1-4A-04003G
63A	30mA	<b>3112000840</b>	RCD1-2A-06303G	<b>3112001040</b>	RCD1-4A-06303G
80A	30mA	<b>3112000870</b>	RCD1-2A-08003G	<b>3112001080</b>	RCD1-4A-08003G
100A	30mA	<b>3112000900</b>	RCD1-2A-10003G	<b>3112001120</b>	RCD1-4A-10003G
125A	30mA	<b>3112000930</b>	RCD1-2A-12503G	<b>3112001160</b>	RCD1-4A-12503G
<b>Type A[G]</b>					
In (A)	Sensitivity	2 pole		4 pole	
25A	100mA	<b>3112000780</b>	RCD1-2A-02510G	<b>3112000970</b>	RCD1-4A-02510G
40A	100mA	<b>3112000820</b>	RCD1-2A-04010G	<b>3112001010</b>	RCD1-4A-04010G
63A	100mA	<b>3112000850</b>	RCD1-2A-06310G	<b>3112001050</b>	RCD1-4A-06310G
80A	100mA	<b>3112000880</b>	RCD1-2A-08010G	<b>3112001090</b>	RCD1-4A-08010G
100A	100mA	<b>3112000910</b>	RCD1-2A-10010G	<b>3112001130</b>	RCD1-4A-10010G
125A	100mA	<b>3112000940</b>	RCD1-2A-12510G	<b>3112001170</b>	RCD1-4A-12510G
<b>Type A[G]</b>					
In (A)	Sensitivity	2 pole		4 pole	
25A	300mA	<b>3112000790</b>	RCD1-2A-02530G	<b>3112000980</b>	RCD1-4A-02530G
40A	300mA	<b>3112000830</b>	RCD1-2A-04030G	<b>3112001020</b>	RCD1-4A-04030G
63A	300mA	<b>3112000860</b>	RCD1-2A-06330G	<b>3112001060</b>	RCD1-4A-06330G
80A	300mA	<b>3112000890</b>	RCD1-2A-08030G	<b>3112001100</b>	RCD1-4A-08030G
100A	300mA	<b>3112000920</b>	RCD1-2A-10030G	<b>3112001140</b>	RCD1-4A-10030G
125A	300mA	<b>3112000950</b>	RCD1-2A-12530G	<b>3112001180</b>	RCD1-4A-12530G
<b>Type A[G]</b>					
In (A)	Sensitivity	2 pole		4 pole	
25A	500mA			<b>3112000990</b>	RCD1-4A-02550G
40A	500mA			<b>3112001030</b>	RCD1-4A-04050G
63A	500mA			<b>3112001070</b>	RCD1-4A-06350G
80A	500mA			<b>3112001110</b>	RCD1-4A-08050G
100A	500mA			<b>3112001150</b>	RCD1-4A-10050G
125A	500mA			<b>3112001190</b>	RCD1-4A-12550G
<b>Auxiliary contact</b>					
1 change over		<b>3105300001</b>	RCD-AUX	<b>3105300001</b>	RCD-AUX





Type A[S]		Order code			
In (A)	Sensitivity	2 pole		4 pole	
40A	100mA	<b>3112000110</b>	RCD1-2A-04010S	<b>3112000370</b>	RCD1-4A-02510S
63A	100mA	<b>3112000160</b>	RCD1-2A-06310S	<b>3112000430</b>	RCD1-4A-04010S
80A	100mA	<b>3112000210</b>	RCD1-2A-08010S	<b>3112000500</b>	RCD1-4A-06310S
100A	100mA	<b>3112000260</b>	RCD1-2A-10010S	<b>3112000570</b>	RCD1-4A-08010S
125A	100mA	<b>3112000310</b>	RCD1-2A-12510S	<b>3112000640</b>	RCD1-4A-10010S
				<b>3112000710</b>	RCD1-4A-12510S
Type A[S]	In (A)	Sensitivity			
40A	300mA	<b>3112000120</b>	RCD1-2A-04030S	<b>3112000380</b>	RCD1-4A-02530S
63A	300mA	<b>3112000170</b>	RCD1-2A-06330S	<b>3112000440</b>	RCD1-4A-04030S
80A	300mA	<b>3112000220</b>	RCD1-2A-08030S	<b>3112000510</b>	RCD1-4A-06330S
100A	300mA	<b>3112000270</b>	RCD1-2A-10030S	<b>3112000580</b>	RCD1-4A-08030S
125A	300mA	<b>3112000320</b>	RCD1-2A-12530S	<b>3112000650</b>	RCD1-4A-10030S
				<b>3112000720</b>	RCD1-4A-12530S
Type A[S]	In (A)	Sensitivity			
40A	500mA			<b>3112000450</b>	RCD1-4A-04050S
63A	500mA			<b>3112000520</b>	RCD1-4A-06350S
80A	500mA			<b>3112000590</b>	RCD1-4A-08050S
100A	500mA			<b>3112000660</b>	RCD1-4A-10050S
125A	500mA			<b>3112000730</b>	RCD1-4A-12550S
Auxiliary contact					
1 change over			<b>3105300001</b>	RCD-AUX	<b>3105300001</b>





#### General

The RCD1 provides diverse RCCB protection devices for different situations. It covers solutions up to 125A in various categories, making it suitable for our changing lifestyle and high-tech developments.



Powered by DEKRA

#### General parameters

High breaking capacity up to 10kA
With handle lock, protective cover and seal function, to protect for error operation
Regular monthly testing of RCBO is legally required and the responsibility of end-users. Failure to comply may result in safety hazards

#### Electrical parameters

Tested according		IEC/EN 61008-1 + IEC/EN 62423
Rated operational voltage	U <sub>e</sub>	240/415VAC
Dependent on line voltage		No
Rated frequency		50/60Hz
Rated breaking capacity	I <sub>nc</sub>	10kA
Poles		2p (1p+n) / 4p (3p+n)
Rated current	I <sub>n</sub>	25A, 40A, 63A, 80A, 100A, 125A
Residual current		30, 100, 300m, 500mA
Waveform		B (including A and AC )
DC component		≥ 6mA
Time delay		Without time delay
Rated isolation voltage	U <sub>i</sub>	500V
Rated impulse withstand voltage	U <sub>imp</sub>	6 kV
Rated making and breaking capacity	I <sub>m</sub>	3000A
Residual making and breaking capacity	I <sub>dm</sub>	3000A
Electrical service life		4000 operations
Mechanical service life		20000 operations
Backup fuse for short circuit		Max. 125A gG
Line voltage connection		Arbitrary (above or below)

#### Mechanical parameters

Device width		36mm (2 pole) / 72mm (4 pole)
Device height		90mm
Device depth		72mm
Mounting		Easy fastening onto 35mm device rail (DIN)
Degree of protection (all sides)		IP40
Terminals		Combined lift + open mouthed
Terminal capacity		4-50mm <sup>2</sup> (solid) 4-35mm <sup>2</sup> (cord-end)
Fastening torque of terminals		3.5Nm
Busbar connection		Fork/Pin type
Busbar thickness		10mm <sup>2</sup> , 16mm <sup>2</sup> , 30mm <sup>2</sup>
Storage temperature		-25°C + 70°C
Reference temperature		30°C
Ambient temperature		-25°C + 40°C (with daily average < 35°C)
Resistance to humidity and heat		Class 2
Installation class		III
Pollution degree		2
Weight		0,28 kg (2-pole), 0,44 kg (4-pole)





		Order code			
		2 pole		4 pole	
<b>Type B</b>					
In (A)	Sensitivity				
25A	30mA	<b>3112001200</b>	RCD1-2B-02503	<b>3112001480</b>	RCD1-4B-02503
40A	30mA	<b>3112001230</b>	RCD1-2B-04003	<b>3112001540</b>	RCD1-4B-04003
63A	30mA	<b>3112001280</b>	RCD1-2B-06303	<b>3112001610</b>	RCD1-4B-06303
80A	30mA	<b>3112001330</b>	RCD1-2B-08003	<b>3112001680</b>	RCD1-4B-08003
100A	30mA	<b>3112001380</b>	RCD1-2B-10003	<b>3112001750</b>	RCD1-4B-10003
125A	30mA	<b>3112001430</b>	RCD1-2B-12503	<b>3112001820</b>	RCD1-4B-12503
<b>Type B</b>					
In (A)	Sensitivity				
25A	100mA	<b>3112001210</b>	RCD1-2B-02510	<b>3112001490</b>	RCD1-4B-02510
40A	100mA	<b>3112001240</b>	RCD1-2B-04010	<b>3112001550</b>	RCD1-4B-04010
63A	100mA	<b>3112001290</b>	RCD1-2B-06310	<b>3112001620</b>	RCD1-4B-06310
80A	100mA	<b>3112001340</b>	RCD1-2B-08010	<b>3112001690</b>	RCD1-4B-08010
100A	100mA	<b>3112001390</b>	RCD1-2B-10010	<b>3112001760</b>	RCD1-4B-10010
125A	100mA	<b>3112001440</b>	RCD1-2B-12510	<b>3112001830</b>	RCD1-4B-12510
<b>Type B</b>					
In (A)	Sensitivity				
25A	300mA	<b>3112001220</b>	RCD1-2B-02530	<b>3112001500</b>	RCD1-4B-02530
40A	300mA	<b>3112001250</b>	RCD1-2B-04030	<b>3112001560</b>	RCD1-4B-04030
63A	300mA	<b>3112001300</b>	RCD1-2B-06330	<b>3112001630</b>	RCD1-4B-06330
80A	300mA	<b>3112001350</b>	RCD1-2B-08030	<b>3112001700</b>	RCD1-4B-08030
100A	300mA	<b>3112001400</b>	RCD1-2B-10030	<b>3112001770</b>	RCD1-4B-10030
125A	300mA	<b>3112001450</b>	RCD1-2B-12530	<b>3112001840</b>	RCD1-4B-12530
<b>Type B</b>					
In (A)	Sensitivity				
25A	500mA			<b>3112001510</b>	RCD1-4B-02550
40A	500mA			<b>3112001570</b>	RCD1-4B-04050
63A	500mA			<b>3112001640</b>	RCD1-4B-06350
80A	500mA			<b>3112001710</b>	RCD1-4B-08050
100A	500mA			<b>3112001780</b>	RCD1-4B-10050
125A	500mA			<b>3112001850</b>	RCD1-4B-12550
<b>Auxiliary contact</b>					
1 change over		<b>3105300001</b>	RCD-AUX	<b>3105300001</b>	RCD-AUX





### General

The INS1 miniature circuit breaker is ideal for various applications, including domestic, utility, and industrial settings. Despite its small size, it has a high short-circuit value of 80-125 amperes, making it an exceptional product. It can also be combined with up to three signal contacts, and is available in different sensitivity levels and amperages to suit various applications.



### General parameters

High breaking capacity up to 10kA for IEC/EN 60898-1 whole range and 15kA for IEC/EN 60947-2
Only 18mm per pole
With terminal cover protection

### Electrical parameters

Tested according		IEC/EN 60898-1	IEC/EN 60947-2
Rated operational voltage	Ue	240 / 415 VAC	
Minimum working voltage	Umin	12V AC/DC	
Rated frequency		50/60Hz	
Rated short-circuit capacity	Icn	10kA	15kA
Rated making and breaking capacity	Icn1	10kA	15kA
Poles		1p, 1p+n, 2p, 3p, 3p+n, 4p	
Rated current	In	1, 2, 3, 4, 6, 8, 10, 13, 16, 20, 25, 32, 40, 50, 63A	
Tripping characteristics		B, C, D	4xIn, 8xIn, 12xIn
Category			Cat. A
Rated impulse withstand	Uimp	6kV	
Rated insulation voltage	Ui	500V	
Transient overvoltage category		3	
Selectivity class		3	
Energy limiting class		3	
Dielectric test voltage		4kV (1min)	
Mechanical life time		≥ 10 000	≥ 7 000
Electrical life time		≥ 4 000	≥ 1 500
Max. back-up fuse		Max. 125A gG	
Line voltage connection		Arbitrary above or below	

### Mechanical parameters

Device width	17,8mm (each pole)
Device height	90mm
Device depth	69mm
Mounting	Easy fastening onto 35mm device rail (DIN)
Degree of protection (all sides)	IP40
Degree of protection (connection terminals)	IP20
Connection possibility	Cable / busbar
Terminals	Cage clamp terminal
Terminal capacity	1-50mm <sup>2</sup> (solid wire) 1-35mm <sup>2</sup> (stranded wire)
Fastening torque of terminals	2.5Nm
Busbar connection	Fork / Pin type
Busbar thickness	10 / 16 / 30mm <sup>2</sup>
Storage temperature	-25°C + 70°C
Reference temperature	30°C
Ambient temperature	-25°C + 40°C (with daily average < 35°C)
Resistance to humidity and heat	Class 2
Installation class	III
Pollution degree	2
Weight	

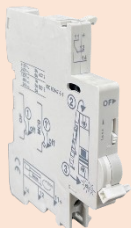

Order code

1p In(A)	Curve B		Curve C		Curve D	
	1	3111000010	INS1-1B01	3111000190	INS1-1C01	3111000370
2	3111000020	INS1-1B02	3111000200	INS1-1C02	3111000380	INS1-1D02
3	3111000030	INS1-1B03	3111000210	INS1-1C03	3111000390	INS1-1D03
4	3111000040	INS1-1B04	3111000220	INS1-1C04	3111000400	INS1-1D04
6	3111000050	INS1-1B06	3111000230	INS1-1C06	3111000410	INS1-1D06
8	3111000060	INS1-1B08	3111000240	INS1-1C08	3111000420	INS1-1D08
10	3111000070	INS1-1B10	3111000250	INS1-1C10	3111000430	INS1-1D10
13	3111000080	INS1-1B13	3111000260	INS1-1C13	3111000440	INS1-1D13
16	3111000090	INS1-1B16	3111000270	INS1-1C16	3111000450	INS1-1D16
20	3111000100	INS1-1B20	3111000280	INS1-1C20	3111000460	INS1-1D20
25	3111000110	INS1-1B25	3111000290	INS1-1C25	3111000470	INS1-1D25
32	3111000120	INS1-1B32	3111000300	INS1-1C32	3111000480	INS1-1D32
40	3111000130	INS1-1B40	3111000310	INS1-1C40	3111000490	INS1-1D40
50	3111000140	INS1-1B50	3111000320	INS1-1C50	3111000500	INS1-1D50
63	3111000150	INS1-1B63	3111000330	INS1-1C63	3111000510	INS1-1D63
<b>2p</b>						
In(A)						
1	3111000550	INS1-2B01	3111000730	INS1-2C01	3111000910	INS1-2D01
2	3111000560	INS1-2B02	3111000740	INS1-2C02	3111000920	INS1-2D02
3	3111000570	INS1-2B03	3111000750	INS1-2C03	3111000930	INS1-2D03
4	3111000580	INS1-2B04	3111000760	INS1-2C04	3111000940	INS1-2D04
6	3111000590	INS1-2B06	3111000770	INS1-2C06	3111000950	INS1-2D06
8	3111000600	INS1-2B08	3111000780	INS1-2C08	3111000960	INS1-2D08
10	3111000610	INS1-2B10	3111000790	INS1-2C10	3111000970	INS1-2D10
13	3111000620	INS1-2B13	3111000800	INS1-2C13	3111000980	INS1-2D13
16	3111000630	INS1-2B16	3111000810	INS1-2C16	3111000990	INS1-2D16
20	3111000640	INS1-2B20	3111000820	INS1-2C20	3111001000	INS1-2D20
25	3111000650	INS1-2B25	3111000830	INS1-2C25	3111001010	INS1-2D25
32	3111000660	INS1-2B32	3111000840	INS1-2C32	3111001020	INS1-2D32
40	3111000670	INS1-2B40	3111000850	INS1-2C40	3111001030	INS1-2D40
50	3111000680	INS1-2B50	3111000860	INS1-2C50	3111001040	INS1-2D50
63	3111000690	INS1-2B63	3111000870	INS1-2C63	3111001050	INS1-2D63
<b>Auxiliary contact</b>						
1 change over	3104500001	RCE1-AUX	3104500001	RCE1-AUX	3104500001	RCE1-AUX





Order code

3p In(A)	Curve B		Curve C		Curve D	
	1	3111001090	INS1-3B01	3111001270	INS1-3C01	3111001450
2	3111001100	INS1-3B02	3111001280	INS1-3C02	3111001460	INS1-3D02
3	3111001110	INS1-3B03	3111001290	INS1-3C03	3111001470	INS1-3D03
4	3111001120	INS1-3B04	3111001300	INS1-3C04	3111001480	INS1-3D04
6	3111001130	INS1-3B06	3111001310	INS1-3C06	3111001490	INS1-3D06
8	3111001140	INS1-3B08	3111001320	INS1-3C08	3111001500	INS1-3D08
10	3111001150	INS1-3B10	3111001330	INS1-3C10	3111001510	INS1-3D10
13	3111001160	INS1-3B13	3111001340	INS1-3C13	3111001520	INS1-3D13
16	3111001170	INS1-3B16	3111001350	INS1-3C16	3111001530	INS1-3D16
20	3111001180	INS1-3B20	3111001360	INS1-3C20	3111001540	INS1-3D20
25	3111001190	INS1-3B25	3111001370	INS1-3C25	3111001550	INS1-3D25
32	3111001200	INS1-3B32	3111001380	INS1-3C32	3111001560	INS1-3D32
40	3111001210	INS1-3B40	3111001390	INS1-3C40	3111001570	INS1-3D40
50	3111001220	INS1-3B50	3111001400	INS1-3C50	3111001580	INS1-3D50
63	3111001230	INS1-3B63	3111001410	INS1-3C63	3111001590	INS1-3D63
4p In(A)	Curve B		Curve C		Curve D	
	1	3111001630	INS1-4B01	3111001810	INS1-4C01	3111001990
2	3111001640	INS1-4B02	3111001820	INS1-4C02	3111002000	INS1-4D02
3	3111001650	INS1-4B03	3111001830	INS1-4C03	3111002010	INS1-4D03
4	3111001660	INS1-4B04	3111001840	INS1-4C04	3111002020	INS1-4D04
6	3111001670	INS1-4B06	3111001850	INS1-4C06	3111002030	INS1-4D06
8	3111001680	INS1-4B08	3111001860	INS1-4C08	3111002040	INS1-4D08
10	3111001690	INS1-4B10	3111001870	INS1-4C10	3111002050	INS1-4D10
13	3111001700	INS1-4B13	3111001880	INS1-4C13	3111002060	INS1-4D13
16	3111001710	INS1-4B16	3111001890	INS1-4C16	3111002070	INS1-4D16
20	3111001720	INS1-4B20	3111001900	INS1-4C20	3111002080	INS1-4D20
25	3111001730	INS1-4B25	3111001910	INS1-4C25	3111002090	INS1-4D25
32	3111001740	INS1-4B32	3111001920	INS1-4C32	3111002100	INS1-4D32
40	3111001750	INS1-4B40	3111001930	INS1-4C40	3111002110	INS1-4D40
50	3111001760	INS1-4B50	3111001940	INS1-4C50	3111002120	INS1-4D50
63	3111001770	INS1-4B63	3111001950	INS1-4C63	3111002130	INS1-4D63
Auxiliary contact	Curve B		Curve C		Curve D	
1 change over	3104500001	RCE1-AUX	3104500001	RCE1-AUX	3104500001	RCE1-AUX



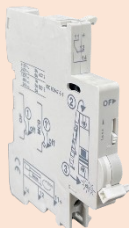

Order code

1p+n In(A)	Curve B		Curve C		Curve D	
	Article no.	Type	Article no.	Type	Article no.	Type
1	3111002170	INS1-1NB01	3111002350	INS1-1NC01	3111002530	INS1-1ND01
2	3111002180	INS1-1NB02	3111002360	INS1-1NC02	3111002540	INS1-1ND02
3	3111002190	INS1-1NB03	3111002370	INS1-1NC03	3111002550	INS1-1ND03
4	3111002200	INS1-1NB04	3111002380	INS1-1NC04	3111002560	INS1-1ND04
6	3111002210	INS1-1NB06	3111002390	INS1-1NC06	3111002570	INS1-1ND06
8	3111002220	INS1-1NB08	3111002400	INS1-1NC08	3111002580	INS1-1ND08
10	3111002230	INS1-1NB10	3111002410	INS1-1NC10	3111002590	INS1-1ND10
13	3111002240	INS1-1NB13	3111002420	INS1-1NC13	3111002600	INS1-1ND13
16	3111002250	INS1-1NB16	3111002430	INS1-1NC16	3111002610	INS1-1ND16
20	3111002260	INS1-1NB20	3111002440	INS1-1NC20	3111002620	INS1-1ND20
25	3111002270	INS1-1NB25	3111002450	INS1-1NC25	3111002630	INS1-1ND25
32	3111002280	INS1-1NB32	3111002460	INS1-1NC32	3111002640	INS1-1ND32
40	3111002290	INS1-1NB40	3111002470	INS1-1NC40	3111002650	INS1-1ND40
50	3111002300	INS1-1NB50	3111002480	INS1-1NC50	3111002660	INS1-1ND50
63	3111002310	INS1-1NB63	3111002490	INS1-1NC63		
<b>3p+n</b>						
In(A)	Article no.	Type	Article no.	Type	Article no.	Type
1	3111002710	INS1-3NB01	3111002890	INS1-3NC01	3111003070	INS1-3ND01
2	3111002720	INS1-3NB02	3111002900	INS1-3NC02	3111003080	INS1-3ND02
3	3111002730	INS1-3NB03	3111002910	INS1-3NC03	3111003090	INS1-3ND03
4	3111002740	INS1-3NB04	3111002920	INS1-3NC04	3111003100	INS1-3ND04
6	3111002750	INS1-3NB06	3111002930	INS1-3NC06	3111003110	INS1-3ND06
8	3111002760	INS1-3NB08	3111002940	INS1-3NC08	3111003120	INS1-3ND08
10	3111002770	INS1-3NB10	3111002950	INS1-3NC10	3111003130	INS1-3ND10
13	3111002780	INS1-3NB13	3111002960	INS1-3NC13	3111003140	INS1-3ND13
16	3111002790	INS1-3NB16	3111002970	INS1-3NC16	3111003150	INS1-3ND16
20	3111002800	INS1-3NB20	3111002980	INS1-3NC20	3111003160	INS1-3ND20
25	3111002810	INS1-3NB25	3111002990	INS1-3NC25	3111003170	INS1-3ND25
32	3111002820	INS1-3NB32	3111003000	INS1-3NC32	3111003180	INS1-3ND32
40	3111002830	INS1-3NB40	3111003010	INS1-3NC40	3111003190	INS1-3ND40
50	3111002840	INS1-3NB50	3111003020	INS1-3NC50	3111003200	INS1-3ND50
63	3111002850	INS1-3NB63	3111003030	INS1-3NC63	3111003210	INS1-3ND63
<b>Auxiliary contact</b>						
1 change over	3104500001	RCE1-AUX	3104500001	RCE1-AUX	3104500001	RCE1-AUX





### General

The SEP RCM RCBO is a protective device against residual current, short-circuit and overload. It is suitable for AC circuits of 50/60Hz, rated voltage of 240/415V and a rated current up to 40A (1p+n up to 63A). It is mainly used to protect human safety from electrical shock and to prevent fire disaster caused by overload or by residual current due to damaged equipment. It also can be used in the infrequent on-and-off switching operation under the normal cases. This RCBO is mainly used in the domestic, utility and industrial application.



### General parameters

High limiting on short circuit current

Regular monthly testing of RCBO is legally required and the responsibility of end-users. Failure to comply may result in safety hazards

### Electrical parameters

Tested according		IEC/EN 61009
Rated operational voltage	Ue	230VAC / 400VAC
Depended on line voltage		No
Rated frequency		50/60Hz
Rated short-circuit capacity	Icn	6kA
Rated making and breaking capacity	Icn1	6kA
Poles		2p (1p+n) and 4p (3p+n)
Protected poles		1 or 3
Switching neutral pole		Yes
Rated current	In	6, 10, 16, 20, 25, 32, 40A (50A, 63A)
Residual current		10mA, 30mA, 100mA, 300mA
Waveform		A type (residual AC and pulsating DC current)
Tripping characteristics		B, C
Energy limiting class		3
Transient overvoltage category		3
Rated isolation voltage	Ui	500V
Rated impulse withstand voltage	Uimp	4 kV
Dielectric test voltage		6 kV
Electrical service life		10 000 operations
Mechanical service life		4 000 operations
Backup fuse for short circuit		Max. 125A gG
Mechanical service life		Arbitrary – above or below

### Mechanical parameters

Device width		36mm (1p+n), 72mm (3p+n)
Device height		89mm
Device depth		69mm
Mounting		Easy fastening onto 35mm device rail (DIN)
Degree of protection (all sides)		IP40
Degree of protection (connection terminals)		IP20
Connection possibility		Cable / Pin-type busbar
Terminals		Combined lift + open mouthed
Terminal capacity		1-35mm <sup>2</sup> (solid) 1-10mm <sup>2</sup> (cord-end)
Fastening torque of terminals		2 Nm
Busbar connection		Fork- or Pin type
Busbar thickness		10/16mm <sup>2</sup>
Storage temperature		-25°C + 70°C
Ambient temperature		-5°C + 40°C (with daily average < 35°C)
Resistance to humidity and heat		Class 2
Installation class		III
Pollution degree		2
Weight		0, kg



1p+n   Type A In(A)      Sensitivity		Order code			
		Curve B		Curve C	
6	10mA	<b>3104540106</b>	RCM2-B06.01	<b>3104550106</b>	RCM2-C06.01
10	10mA	<b>3104540110</b>	RCM2-B10.01	<b>3104550110</b>	RCM2-C10.01
13	10mA	<b>3104540113</b>	RCM2-B13.01	<b>3104550113</b>	RCM2-C13.01
16	10mA	<b>3104540116</b>	RCM2-B16.01	<b>3104550116</b>	RCM2-C16.01
20	10mA	<b>3104540120</b>	RCM2-B20.01	<b>3104550120</b>	RCM2-C20.01
25	10mA	<b>3104540125</b>	RCM2-B25.01	<b>3104550125</b>	RCM2-C25.01
32	10mA	<b>3104540132</b>	RCM2-B32.01	<b>3104550132</b>	RCM2-C32.01
40	10mA	<b>3104540140</b>	RCM2-B40.01	<b>3104550140</b>	RCM2-C40.01
1p+n   Type A In(A)      Sensitivity		Order code			
6	30mA	<b>3104540006</b>	RCM2-B06.03	<b>3104550006</b>	RCM2-C06.03
10	30mA	<b>3104540010</b>	RCM2-B10.03	<b>3104550010</b>	RCM2-C10.03
13	30mA	<b>3104540013</b>	RCM2-B13.03	<b>3104550013</b>	RCM2-C13.03
16	30mA	<b>3104540016</b>	RCM2-B16.03	<b>3104550016</b>	RCM2-C16.03
20	30mA	<b>3104549020</b>	RCM2-B20.03	<b>3104550020</b>	RCM2-C20.03
25	30mA	<b>3104540025</b>	RCM2-B25.03	<b>3104550025</b>	RCM2-C25.03
32	30mA	<b>3104540032</b>	RCM2-B32.03	<b>3104550032</b>	RCM2-C32.03
40	30mA	<b>3104540040</b>	RCM2-B40.03	<b>3104550040</b>	RCM2-C40.03
50	30mA	<b>3104540050</b>	RCM2-B50.03	<b>3104550050</b>	RCM2-C50.03
63	30mA	<b>3104540063</b>	RCM2-B63.03	<b>3104550063</b>	RCM2-C63.03
1p+n   Type A In(A)      Sensitivity		Order code			
6	100mA	<b>3104540206</b>	RCM2-B06.10	<b>3104550206</b>	RCM2-C06.10
10	100mA	<b>3104540210</b>	RCM2-B10.10	<b>3104550210</b>	RCM2-C10.10
13	100mA	<b>3104540213</b>	RCM2-B13.10	<b>3104550213</b>	RCM2-C13.10
16	100mA	<b>3104540216</b>	RCM2-B16.10	<b>3104550216</b>	RCM2-C16.10
20	100mA	<b>3104540220</b>	RCM2-B20.10	<b>3104550220</b>	RCM2-C20.10
25	100mA	<b>3104540225</b>	RCM2-B25.10	<b>3104550225</b>	RCM2-C25.10
32	100mA	<b>3104540232</b>	RCM2-B32.10	<b>3104550232</b>	RCM2-C32.10
40	100mA	<b>3104540240</b>	RCM2-B40.10	<b>3104550240</b>	RCM2-C40.10
50	100mA	<b>3104540250</b>	RCM2-B50.10	<b>3104550250</b>	RCM2-C50.10
63	100mA	<b>3104540263</b>	RCM2-B63.10	<b>3104550263</b>	RCM2-C63.10
1p+n   Type A In(A)      Sensitivity		Order code			
6	300mA	<b>3104540306</b>	RCM2-B06.30	<b>3104550306</b>	RCM2-C06.30
10	300mA	<b>3104540310</b>	RCM2-B10.30	<b>3104550310</b>	RCM2-C10.30
13	300mA	<b>3104540313</b>	RCM2-B13.30	<b>3104550313</b>	RCM2-C13.30
16	300mA	<b>3104540316</b>	RCM2-B16.30	<b>3104550316</b>	RCM2-C16.30
20	300mA	<b>3104540320</b>	RCM2-B20.30	<b>3104550320</b>	RCM2-C20.30
25	300mA	<b>3104540325</b>	RCM2-B25.30	<b>3104550325</b>	RCM2-C25.30
32	300mA	<b>3104540332</b>	RCM2-B32.30	<b>3104550332</b>	RCM2-C32.30
40	300mA	<b>3104540340</b>	RCM2-B40.30	<b>3104550340</b>	RCM2-C40.30
50	300mA	<b>3104540350</b>	RCM2-B50.30	<b>3104550350</b>	RCM2-C50.30
63	300mA	<b>3104540363</b>	RCM2-B63.30	<b>3104550363</b>	RCM2-C63.30
Contacts 1 change over		Order code			
Auxiliary		<b>3104000010</b>	RCM-AUX	<b>3104000010</b>	RCM-AUX
Tripping		<b>3104000020</b>	RCM-ALT	<b>3104000020</b>	RCM-ALT
		Order code			
Terminal cover		Order code			
Yellow		<b>5102290010</b>	DH-C2	<b>5102290010</b>	DH-C2





3p+n   Type A		Order code			
In(A)	Sensitivity	Curve B		Curve C	
6	30mA	<b>3104640006</b>	RCM4-B06.03	<b>3104650006</b>	RCM4-C06.03
10	30mA	<b>3104640010</b>	RCM4-B10.03	<b>3104650010</b>	RCM4-C10.03
16	30mA	<b>3104640016</b>	RCM4-B16.03	<b>3104650016</b>	RCM4-C16.03
20	30mA	<b>3104640020</b>	RCM4-B20.03	<b>3104650020</b>	RCM4-C20.03
25	30mA	<b>3104640025</b>	RCM4-B25.03	<b>3104650025</b>	RCM4-C25.03
32	30mA	<b>3104640032</b>	RCM4-B32.03	<b>3104650032</b>	RCM4-C32.03
40	30mA	<b>3104640040</b>	RCM4-B40.03	<b>3104650040</b>	RCM4-C40.03
<b>3p+n   Type A</b>					
In(A)	Sensitivity	Curve B		Curve C	
6	100mA	<b>3104640206</b>	RCM4-B06.10	<b>3104650206</b>	RCM4-C06.10
10	100mA	<b>3104640210</b>	RCM4-B10.10	<b>3104650210</b>	RCM4-C10.10
16	100mA	<b>3104640216</b>	RCM4-B16.10	<b>3104650216</b>	RCM4-C16.10
20	100mA	<b>3104640220</b>	RCM4-B20.10	<b>3104650220</b>	RCM4-C20.10
25	100mA	<b>3104640225</b>	RCM4-B25.10	<b>3104650225</b>	RCM4-C25.10
32	100mA	<b>3104640232</b>	RCM4-B32.10	<b>3104650232</b>	RCM4-C32.10
40	100mA	<b>3104640240</b>	RCM4-B40.10	<b>3104650240</b>	RCM4-C40.10
<b>3p+n   Type A</b>					
In(A)	Sensitivity	Curve B		Curve C	
6	300mA	<b>3104641006</b>	RCM4-B06.30	<b>3104651006</b>	RCM4-C06.30
10	300mA	<b>3104641010</b>	RCM4-B10.30	<b>3104651010</b>	RCM4-C10.30
16	300mA	<b>3104641016</b>	RCM4-B16.30	<b>3104651016</b>	RCM4-C16.30
20	300mA	<b>3104641020</b>	RCM4-B20.30	<b>3104651020</b>	RCM4-C20.30
25	300mA	<b>3104641025</b>	RCM4-B25.30	<b>3104651025</b>	RCM4-C25.30
32	300mA	<b>3104641032</b>	RCM4-B32.30	<b>3104651032</b>	RCM4-C32.30
40	300mA	<b>3104641040</b>	RCM4-B40.30	<b>3104651040</b>	RCM4-C40.30
<b>Contacts 1 change over</b>					
Auxiliary		<b>3104000010</b>	RCM-AUX	<b>3104000010</b>	RCM-AUX
Tripping		<b>3104000020</b>	RCM-ALT	<b>3104000020</b>	RCM-ALT
<b>Terminal cover</b>					
Yellow		<b>5102490010</b>	DH-C4	<b>5102290010</b>	DH-C4





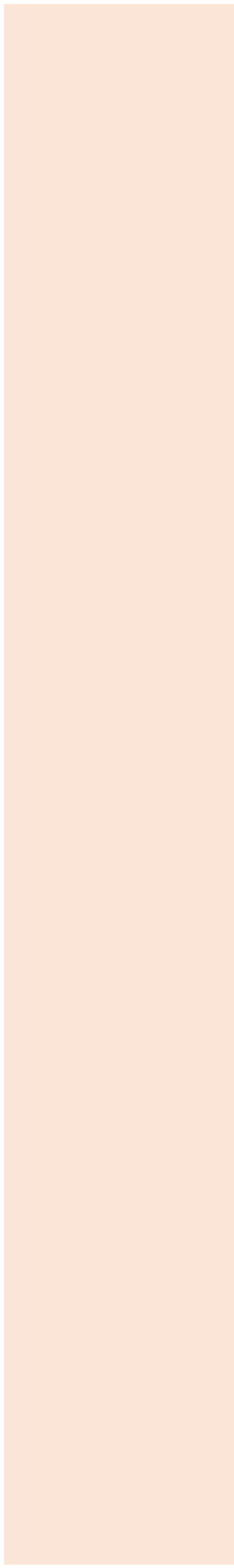



### General

The SEP RCM RCBO is an advanced protective device that offers protection against residual current, short-circuit, and overload. It can operate effectively in AC circuits with 50/60Hz frequency, rated voltage of 240/415V, and rated current of up to 40A (1p+n up to 63A). Its primary purpose is to ensure human safety by preventing electrical shocks and fire disasters caused by overload or residual current from damaged equipment. The RCBO is suitable for domestic, utility, and industrial applications, and can also handle infrequent on-and-off switching operations.



### General parameters

High limiting on short circuit current

Regular monthly testing of RCBO is legally required and the responsibility of end-users. Failure to comply may result in safety hazards

### Electrical parameters

Tested according		IEC/EN 61009 / IEC/EN62423
Rated operational voltage	U <sub>e</sub>	230VAC / 400VAC
Depended on line voltage		No
Rated frequency		50/60Hz
Rated short-circuit capacity	I <sub>cn</sub>	6kA
Rated making and breaking capacity	I <sub>cn1</sub>	6kA
Poles		2p (1p+n) and 4p (3p+n)
Protected poles		1 or 3
Switching neutral pole		Yes
Rated current	I <sub>n</sub>	6, 10, 16, 20, 25, 32, 40A
Residual current		30mA, 300mA
Waveform		B type (including A and AC)
Tripping characteristics		B, C
Energy limiting class		3
Transient overvoltage category		3
Rated isolation voltage	U <sub>i</sub>	500V
Rated impulse withstand voltage	U <sub>imp</sub>	4 kV
Dielectric test voltage		6 kV
Electrical service life		10 000 operations
Mechanical service life		4 000 operations
Backup fuse for short circuit		Max. 125A gG
Mechanical service life		Arbitrary – above or below

### Mechanical parameters

Device width		45mm (1p+n), 81mm (3p+n)
Device height		89mm
Device depth		69mm
Mounting		Easy fastening onto 35mm device rail (DIN)
Degree of protection (all sides)		IP40
Degree of protection (connection terminals)		IP20
Connection possibility		Cable / Pin-type busbar
Terminals		Combined lift + open mouthed
Terminal capacity		1-35mm <sup>2</sup> (solid)
Fastening torque of terminals		2 Nm
Busbar connection		Fork- or Pin type
Busbar thickness		10/16mm <sup>2</sup>
Storage temperature		-25°C + 70°C
Ambient temperature		-5°C + 40°C (with daily average < 35°C)
Resistance to humidity and heat		Class 2
Installation class		III
Pollution degree		2
Weight		0, 222kg / 0,474kg



1p+n   Type B		Order code			
In(A)	Sensitivity	Curve B		Curve C	
6	30mA	3104690010	RCMB-2B06.03	3104690080	RCMB-2C06.03
10	30mA	3104690020	RCMB-2B10.03	3104690090	RCMB-2C10.03
16	30mA	3104690030	RCMB-2B16.03	3104690100	RCMB-2C16.03
20	30mA	3104690040	RCMB-2B20.03	3104690110	RCMB-2C20.03
25	30mA	3104690050	RCMB-2B25.03	3104690120	RCMB-2C25.03
32	30mA	3104690060	RCMB-2B32.03	3104690130	RCMB-2C32.03
40	30mA	3104690070	RCMB-2B40.03	3104690140	RCMB-2C40.03

1p+n   Type B		Order code			
In(A)	Sensitivity	Curve B		Curve C	
6	300mA	3104690150	RCMB-2B06.30	3104690220	RCMB-2C06.30
10	300mA	3104690160	RCMB-2B10.30	3104690230	RCMB-2C10.30
16	300mA	3104690170	RCMB-2B16.30	3104690240	RCMB-2C16.30
20	300mA	3104690180	RCMB-2B20.30	3104690250	RCMB-2C20.30
25	300mA	3104690190	RCMB-2B25.30	3104690260	RCMB-2C25.30
32	300mA	3104690200	RCMB-2B32.30	3104690270	RCMB-2C32.30
40	300mA	3104690210	RCMB-2B40.30	3104690280	RCMB-2C40.30



3p+n   Type B		Order code			
In(A)	Sensitivity	Curve B		Curve C	
6	30mA	3104690510	RCMB-4B06.03	3104690580	RCMB-4C06.03
10	30mA	3104690520	RCMB-4B10.03	3104690590	RCMB-4C10.03
16	30mA	3104690530	RCMB-4B16.03	3104690600	RCMB-4C16.03
20	30mA	3104690540	RCMB-4B20.03	3104690610	RCMB-4C20.03
25	30mA	3104690550	RCMB-4B25.03	3104690620	RCMB-4C25.03
32	30mA	3104690560	RCMB-4B32.03	3104690630	RCMB-4C32.03
40	30mA	3104690570	RCMB-4B40.03	3104690640	RCMB-4C40.03

3p+n   Type B		Order code			
In(A)	Sensitivity	Curve B		Curve C	
6	300mA	3104690650	RCMB-4B06.30	3104690720	RCMB-4C06.30
10	300mA	3104690660	RCMB-4B10.30	3104690730	RCMB-4C10.30
16	300mA	3104690670	RCMB-4B16.30	3104690740	RCMB-4C16.30
20	300mA	3104690680	RCMB-4B20.30	3104690750	RCMB-4C20.30
25	300mA	3104690690	RCMB-4B25.30	3104690760	RCMB-4C25.30
32	300mA	3104690700	RCMB-4B32.30	3104690770	RCMB-4C32.30
40	300mA	3104690710	RCMB-4B40.30	3104690780	RCMB-4C40.30

Contacts 1 change over					
Auxiliary		3104000010	RCM-AUX	3104000010	RCM-AUX
Tripping		3104000020	RCM-ALT	3104000020	RCM-ALT



Terminal cover					
Yellow	2 pole	5102290010	DH-C2	5102290010	DH-C2
Yellow	4 pole	5102490010	DH-C4	5102290010	DH-C4



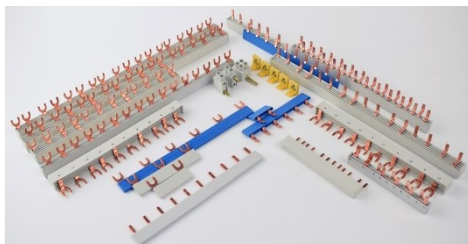

**General**

The SEP insulated busbar system provides a reliable and efficient solution for connecting modular components. It helps to minimize failures and optimize heat management within the cabinet. The use of accessories and reduced wiring within the cabinet improves the overall appearance and organization of the system.



**General parameters**

Insulated busbar
No cutting is necessary as the material is already at the required length
Wide range of busbar
Wide range of connection accessories

**Technical parameters**

Complies with	IEC 60439-1   2000-08
According	IEC 664
Busbar material	E-Cu-ETP
Isolation material	Ultramid PA6 glass fiber reinforced
Form test	125°C (after 1,8MPa)
Glow wire test	960°C according IEC60895-2-12
Flammability class	V0
Tracking index	550
Short circuit strength	25kA / 100A gl
Disruptive strength	36kV / mm
Climate stability	IEC 68-2
Operating voltage	500V AC
Surge voltage	4kV
Isolation group	According VDE 0110-T1
Overtoltage category	III
Degree of soiling	2
Halogen free	According DIN EN 50267-2-2
Colors	Related to RAL7035 and RAL5015 (grey/blue)
Type	PIN and FORK
Cross section	10mm <sup>2</sup>
Max. current one side line-in	63A
Max. current central line-in	100A*

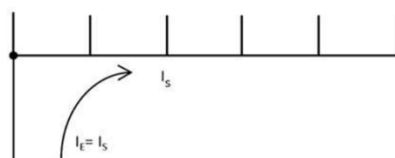

ONE SIDE LINE-IN

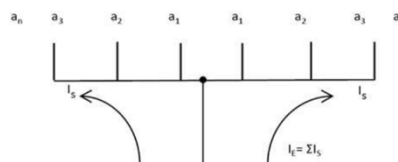

CENTRAL LINE-IN

\* The  $I_s$  is rated on an equal divided demand on both sides of the feeding-main (line-in) of the busbar the sum of the equal divided output current cannot be higher than the busbar current ( $I_s$ )

Order code

1 Phase Busbars (L) number of poles					Fork		Pin	
2	2x 1p	(2MU)	17,8mm	Grey	2305111002	F01002G06	2305101002	P01002G00
3	3x 1p	(3MU)	17,8mm	Grey	2305111003	F01003G06	2305101003	P01003G00
4	4x 1p	(4MU)	17,8mm	Grey	2305111004	F01004G06	2305101004	P01004G00
5	5x 1p	(5MU)	17,8mm	Grey	2305111005	F01005G06	2305101005	P01005G00
6	6x 1p	(6MU)	17,8mm	Grey	2305111006	F01006G06	2305101006	P01006G00
7	7x 1p	(7MU)	17,8mm	Grey	2305111007	F01007G06	2305101007	P01007G00
8	8x 1p	(8MU)	17,8mm	Grey	2305111008	F01008G06	2305101008	P01008G00
9	9x 1p	(9MU)	17,8mm	Grey	2305111009	F01009G06	2305101009	P01009G00
10	10x 1p	(10MU)	17,8mm	Grey	2305111010	F01010G06	2305101010	P01010G00
11	11x 1p	(11MU)	17,8mm	Grey	2305111011	F01011G06	2305101011	P01011G00
12	12x 1p	(12MU)	17,8mm	Grey	2305111012	F01012G06	2305101012	P01012G00
13	13x 1p	(13MU)	17,8mm	Grey	2305111013	F01013G06	2305101013	P01013G00

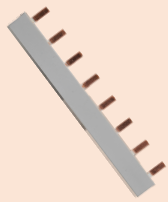

1 Phase Busbars (N) number of poles					Fork		Pin	
2	2x 1p	(2MU)	17,8mm	Blue	2305111902	F01002B06	2305101902	P01002B00
3	3x 1p	(3MU)	17,8mm	Blue	2305111903	F01003B06	2305101903	P01003B00
4	4x 1p	(4MU)	17,8mm	Blue	2305111904	F01004B06	2305101904	P01004B00
5	5x 1p	(5MU)	17,8mm	Blue	2305111905	F01005B06	2305101905	P01005B00
6	6x 1p	(6MU)	17,8mm	Blue	2305111906	F01006B06	2305101906	P01006B00
7	7x 1p	(7MU)	17,8mm	Blue	2305111907	F01007B06	2305101907	P01007B00
8	8x 1p	(8MU)	17,8mm	Blue	2305111908	F01008B06	2305101908	P01008B00
9	9x 1p	(9MU)	17,8mm	Blue	2305111909	F01009B06	2305101909	P01009B00
10	10x 1p	(10MU)	17,8mm	Blue	2305111910	F01010B06	2305101910	P01010B00
11	11x 1p	(11MU)	17,8mm	Blue	2305111911	F01011B06	2305101911	P01011B00
12	12x 1p	(12MU)	17,8mm	Blue	2305111912	F01012B06	2305101912	P01012B00
13	13x 1p	(13MU)	17,8mm	Blue	2305111913	F01013B06	2305101913	P01013B00

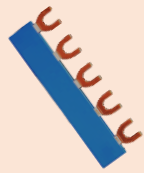

1 Phase Busbars (N) – offset 4mm number of poles					Fork		Pin	
2	2x 1p	(2MU)	17,8mm	Blue			2305101992	P01002B10
3	3x 1p	(3MU)	17,8mm	Blue			2305101993	P01003B10
4	4x 1p	(4MU)	17,8mm	Blue			2305101994	P01004B10
5	5x 1p	(5MU)	17,8mm	Blue			2305101995	P01005B10
6	6x 1p	(6MU)	17,8mm	Blue			2305101996	P01006B10
8	8x 1p	(8MU)	17,8mm	Blue			2305101998	P01008B10
10	10x 1p	(10MU)	17,8mm	Blue			2305101990	P01010B10
12	12x 1p	(12MU)	17,8mm	Blue			2305101991	P01012B10

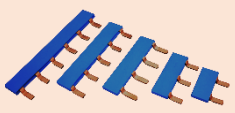

1 Phase Busbars (L) – pitch 35,6mm number of poles					Fork		Pin	
2	2x 1p	(3MU)	35,6mm	Grey	2305181002	F01102G06	2305171002	P01102G00
3	3x 1p	(5MU)	35,6mm	Grey	2305181003	F01103G06	2305171003	P01103G00
4	4x 1p	(7MU)	35,6mm	Grey	2305181004	F01104G06	2305171004	P01104G00
5	5x 1p	(9MU)	35,6mm	Grey	2305181005	F01105G06	2305171005	P01105G00
6	6x 1p	(11MU)	35,6mm	Grey	2305181006	F01106G06	2305171006	P01106G00

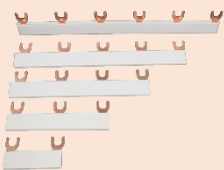

1 Phase Busbars (N) – pitch 35,6mm number of poles					Fork		Pin	
2	2x 1p	(3MU)	35,6mm	Blue	2305181903	F01103B06	2305171902	P01102B00
3	3x 1p	(5MU)	35,6mm	Blue	2305181902	F01102B06	2305171903	P01103B00
4	4x 1p	(7MU)	35,6mm	Blue	2305181904	F01104B06	2305171904	P01104B00
5	5x 1p	(9MU)	35,6mm	Blue	2305181905	F01105B06	2305171905	P01105B00
6	6x 1p	(11MU)	35,6mm	Blue	2305181906	F01106B06	2305171906	P01106B00

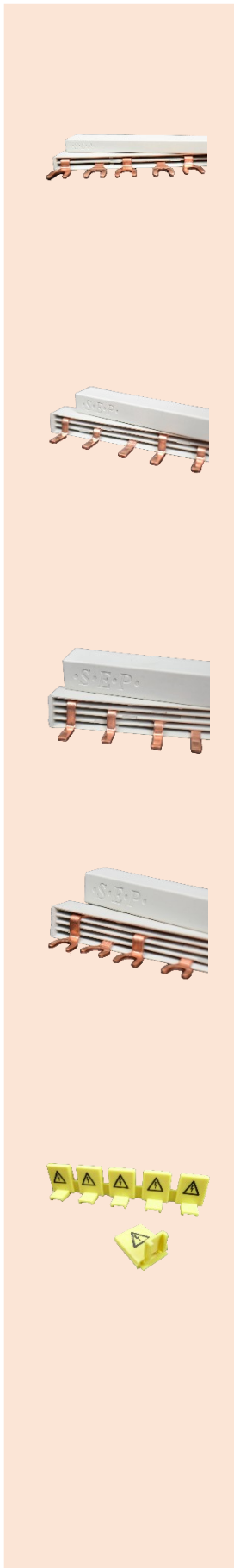

				Order code			
2 Phase Busbars (L-N)				Fork		Pin	
number of poles							
4	2x 2p	(4MU)	17,8mm	2305112004	F02004G06	2305102004	P02004G00
6	3x 2p	(6MU)	17,8mm	2305112006	F02006G06	2305102006	P02006G00
8	4x 2p	(8MU)	17,8mm	2305112008	F02008G06	2305102008	P02008G00
10	5x 2p	(10MU)	17,8mm	2305112010	F02010G06	2305102010	P02010G00
12	6x 2p	(12MU)	17,8mm	2305112012	F02012G06	2305102012	P02012G00
14	7x 2p	(14MU)	17,8mm	2305112014	F02014G06	2305102014	P02014G00
16	8x 2p	(16MU)	17,8mm	2305112016	F02016G06	2305102016	P02016G00
18	9x 2p	(18MU)	17,8mm	2305112018	F02018G06	2305102018	P02018G00
3 Phase Busbars (L1-L2-L3)							
number of poles							
6	2x 3p	(6MU)	17,8mm	2305113006	F03006G06	2305103006	P03006G00
9	3x 3p	(9MU)	17,8mm	2305113009	F03009G06	2305103009	P03009G00
12	4x 3p	(12MU)	17,8mm	2305113012	F03012G06	2305103012	P03012G00
15	5x 3p	(15MU)	17,8mm	2305113015	F03015G06	2305103015	P03015G00
18	6x 3p	(18MU)	17,8mm	2305113018	F03018G06	2305103018	P03018G00
4 Phase Busbars (N-L1-L2-L3)							
number of poles							
8	2x 4p	(8MU)	17,8mm	2305114008	F04008G06	2305104008	P04008G00
12	3x 4p	(12MU)	17,8mm	2305114012	F04012G06	2305104012	P04012G00
16	4x 4p	(16MU)	17,8mm	2305114016	F04016G06	2305104016	P04016G00
3+N Phase Busbars (N-L1-N-L2-N-L3)							
number of poles							
12	6x 2p	(12MU)	17,8mm	2305115012	F04012G56	2305105012	P04012G50
18	9x 2p	(18MU)	17,8mm	2305115018	F04018G56	2305105018	P04018G50
Combination busbars (N-L1-L2-L3-N-L1-N-L2-N-L3)							
number of poles							
10	1x 4p + 3x 2p	(10MU)	17,8mm	2305181903	F14010G56		
Busbar cover							
Protection cover	5x breakable	Yellow		2115900010	IK	2115900010	IK

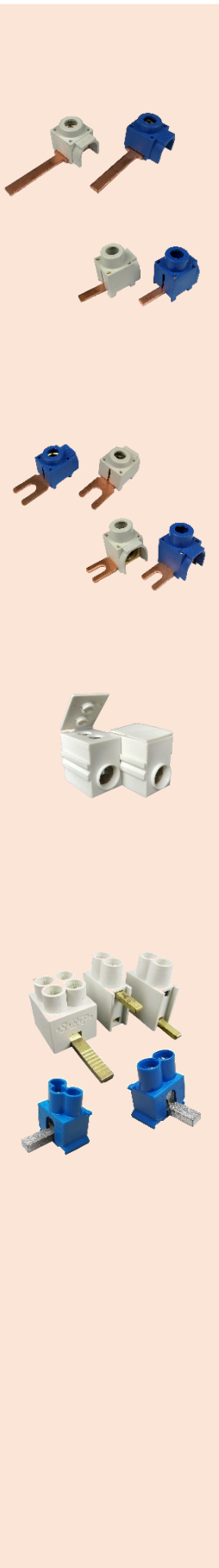

**PIN type connection terminals for busbar**

Cross section	Length connection	Connection way	Order code			
			Grey		Blue	
1x25 mm <sup>2</sup>	15mm	Front	<b>2115925011</b>	SPR-G2515	<b>2115925511</b>	SPR-B2515
1x25 mm <sup>2</sup>	27mm	Front	<b>2115925021</b>	SPR-G2527	<b>2115925521</b>	SPR-B2527
1x25 mm <sup>2</sup>	15mm	Side	<b>2115925012</b>	SPS-G2515	<b>2115925512</b>	SPS-B2515
1x25 mm <sup>2</sup>	27mm	Side	<b>2115925022</b>	SPS-G2527	<b>2115925522</b>	SPS-B2527
1x50mm <sup>2</sup>	15mm	Front	<b>2115950011</b>	SPR-G5015	<b>2115950511</b>	SPR-B5015
1x50 mm <sup>2</sup>	27mm	Front	<b>2115950021</b>	SPR-G5027	<b>2115950521</b>	SPR-B5027
1x50 mm <sup>2</sup>	15mm	Side	<b>2115950012</b>	SPS-G5015	<b>2115950512</b>	SPS-B5015
1x50 mm <sup>2</sup>	27mm	Side	<b>2115950022</b>	SPS-G5027	<b>2115950522</b>	SPS-B5027

**FORK type connection terminals for busbar**

Cross section	Length connection	Connection way	Order code			
			Grey		Blue	
1x25 mm <sup>2</sup>	15mm	Front	<b>2115925031</b>	SFR-G2515	<b>2115925531</b>	SFR-B2515
1x25 mm <sup>2</sup>	15mm	Side	<b>2115925032</b>	SFS-G2515	<b>2115925532</b>	SFS-B2515
1x50mm <sup>2</sup>	15mm	Front	<b>2115950031</b>	SFR-G5015	<b>2115950531</b>	SFR-B5015
1x50 mm <sup>2</sup>	15mm	Side	<b>2115950032</b>	SFS-G5015	<b>2115950532</b>	SFS-B5015

**FEED-IN connection terminal for busbar**

Cross section	Connection way	Order code			
		Grey		Blue	
6-50 mm <sup>2</sup>		<b>2115910050</b>	BFT50		

**PIN type connection terminals**

Cross section	Connection way	Order code			
		Grey		Blue	
2x10 mm <sup>2</sup>	Front/high	<b>2115900040</b>	DTH	<b>2115900540</b>	DTH-B
2x10 mm <sup>2</sup>	Front/low	<b>2115900041</b>	DTL	<b>2115900541</b>	DTL-B
2x16 mm <sup>2</sup>	Front	<b>2115900050</b>	DT	<b>2115900550</b>	DT-B
2x25 mm <sup>2</sup>	Front	<b>2115900225</b>	DT2-25	<b>2115905225</b>	DT2-25
3x16 mm <sup>2</sup>	Front	<b>2115900316</b>	DT3-16	<b>2115905316</b>	DT3-16



#### General

The HS1 isolator switches are highly versatile and meet IEC/EN60947-3 standards for isolation functions. Available in 2p and 4p versions with widths of 27mm and 54mm respectively, these switches can be used as main switches in a variety of applications. Their utilization categories include AC-21A/B, AC-22A/B, and AC-23/AB, which allow them to switch resistive, moderately inductive, and highly inductive loads. Additionally, the switches are suitable for DC-22 and DC-23 applications.



#### General parameters

Isolator switch AC-21 A/B, AC-22 A/B, AC-23 A/B, DC-22 and DC-23  
Suitable for use in households, utilities, and industrial applications  
Including connection covers

#### Electrical parameters

Tested according		IEC/EN 60947-3
Rated operational voltage	U <sub>e</sub>	400/415 VAC
Rated frequency		50/60Hz
Poles		2p, 4p
Rated current	I <sub>n</sub>	25A, 40A, 63A, 80A, 100A, 125A
Utilization category		AC-21A/B, AC-22A/B, AC-23A/B
Rated short-time withstand	I <sub>cw</sub>	1500A / 1s
Rated short-time making capacity	I <sub>cm</sub>	1500A
Rated impulse withstand	U <sub>imp</sub>	6 kV
Rated insulation voltage	U <sub>i</sub>	400V
Dielectric test voltage		2.5 kV
Mechanical life time		10.000 operation cycles
Electrical life time		4.000 operation cycles
Max. back-up fuse		125A gG
Line voltage connection		Arbitrary above or below

#### Mechanical parameters

Device width		27mm (2p) / 54mm (4p)
Device height		83mm
Device depth		77mm
Mounting		Easy fastening onto 35mm device rail (DIN)
Degree of protection (all sides)		IP40
Degree of protection (connection terminals)		IP20
Connection possibility		Cable / busbar
Terminals		Cage clamp terminal
Terminal capacity		2,-50mm <sup>2</sup> (solid) 2,5-35mm <sup>2</sup> (cord-end)
Fastening torque of terminals		2.5 Nm
Busbar connection		Pin type
Busbar thickness		30mm <sup>2</sup>
Storage temperature		-25°C + 70°C
Ambient temperature		-5°C + 40°C (with daily average < 35°C)
Resistance to humidity and heat		Class 2
Installation class		III
Pollution degree		2
Weight		0,149 kg (2p) / 0,293 kg (4p)





	Order code	
<b>2p</b>		
In (A)		
25A	3102210025	HS27-2025
40A	3102210040	HS27-2040
63A	3102210063	HS27-2063
80A	3102210080	HS27-2080
100A	3102210100	HS27-2100
125A	3102210125	HS27-2125
<b>4p</b>		
In (A)		
25A	3102410025	HS27-4025
40A	3102410040	HS27-4040
63A	3102410063	HS27-4063
80A	3102410080	HS27-4080
100A	3102410100	HS27-4100
125A	3102410125	HS27-4125
<b>Marker</b>		
Yellow		
N (78x)	2119100004	CHB-N
L1 (78x)	2119100001	CHB-L1
L2 (78)x	2119100002	CHB-L2
L3 (78x)	2119100003	CHB-L3



### General

The increasing use of electrical installations incorporating power electronics, such as PV inverters and EV chargers, can produce residual currents that standard AC or A type RCCBs cannot detect. The RCD-B provides dual protection against standard 50/60Hz earth leakage currents, smooth DC, and high frequency AC residual currents, making it suitable for a wide range of applications. It can replace the AC and A type RCCBs in all situations.



### General parameters

High breaking capacity up to 10kA  
With handle lock, protective cover and seal function, to protect for error operation  
Regular monthly testing of RCCB is legally required and the responsibility of end-users. Failure to comply may result in safety hazards

### Electrical parameters

Tested according		IEC/EN 61008-1 + IEC/EN 62423
Rated operational voltage	U <sub>e</sub>	240/415VAC
Dependent on line voltage		No
Rated frequency		50/60Hz
Rated breaking capacity	I <sub>nc</sub>	10kA
Poles		2p (1p+n) / 4p (3p+n)
Rated current	I <sub>n</sub>	25A, 40A, 63A
Residual current		30, 100, 300mA
Waveform		B (including A and AC )
DC component		≥ 6mA
Time delay		Without time delay
Rated isolation voltage	U <sub>i</sub>	500V
Rated impulse withstand voltage	U <sub>imp</sub>	4 kV
Rated making and breaking capacity	I <sub>m</sub>	1000A
Residual making and breaking capacity	I <sub>dm</sub>	1000A
Electrical service life		4000 operations
Mechanical service life		10000 operations
Backup fuse for short circuit		Max. 63A gG
Line voltage connection		Arbitrary (above or below)

### Mechanical parameters

Device width		54mm (2 pole) / 72mm (4 pole)
Device height		89mm
Device depth		72mm
Mounting		Easy fastening onto 35mm device rail (DIN)
Degree of protection (all sides)		IP40
Terminals		Combined lift + open mouthed
Terminal capacity		4-50mm <sup>2</sup> (solid) 4-35mm <sup>2</sup> (cord-end)
Fastening torque of terminals		3.5Nm
Busbar connection		Pin type
Busbar thickness		10mm <sup>2</sup> , 16mm <sup>2</sup> , 30mm <sup>2</sup>
Storage temperature		-25°C + 70°C
Reference temperature		30°C
Ambient temperature		-25°C + 40°C (with daily average < 35°C)
Resistance to humidity and heat		Class 2
Installation class		III
Pollution degree		2
Weight		0,28 kg (2-pole), 0,44 kg (4-pole)



Order code

Type B		Order code			
In (A)	Sensitivity	2 pole		4 pole	
25A	30mA	<b>3105300025</b>	RCD-B2025	<b>3105400025</b>	RCD-B4025
40A	30mA	<b>3105300040</b>	RCD-B2040	<b>3105400040</b>	RCD-B4040
63A	30mA	<b>3105300063</b>	RCD-B2063	<b>3105400063</b>	RCD-B4063
<b>Type B</b>					
In (A)	Sensitivity	2 pole		4 pole	
25A	100mA	<b>3105302025</b>	RCD-B2125	<b>3105402025</b>	RCD-B4125
40A	100mA	<b>3105302040</b>	RCD-B2140	<b>3105402040</b>	RCD-B4140
63A	100mA	<b>3105302063</b>	RCD-B2163	<b>3105402063</b>	RCD-B4163
<b>Type B</b>					
In (A)	Sensitivity	2 pole		4 pole	
25A	300mA	<b>3105303025</b>	RCD-B2325	<b>3105403025</b>	RCD-B4325
40A	300mA	<b>3105303040</b>	RCD-B2340	<b>3105403040</b>	RCD-B4340
63A	300mA	<b>3105303063</b>	RCD-B2363	<b>3105403063</b>	RCD-B4363
<b>Auxiliary contact</b>					
1 change over		<b>3105300001</b>	RCD-AUX	<b>3105300001</b>	RCD-AUX







# ***MEASURING AND CONTROLLING MANAGEMENT***



## ***Measuring and controlling management***

---

**3.03 – 3.16**

BTR	-	Bel transformers	03 - 04
WCD	-	Sockets	05 - 06
LND	-	Emergency lights	07 - 08
CPTS	-	Timers	09 - 10
OVB	-	Surge protection devices	11 - 12
SHC	-	Contactors   pulse contactors	13 - 16
LEM	-	Energy meters	... - ...



#### General

The SEP BTR is a versatile device used as a bell transformer and non-continuous power supply for small components. It provides multiple output voltages, including 8-12-24VAC, making it suitable for various applications. The BTR also features an integrated switch, allowing for easy on and off control.



#### General parameters

Suitable for use in households, utilities, and industrial applications

Electrical parameters		BTR-12	BTR-24
Tested according		IEC 61558-2-6 / IEC 61558-2-8	
Rated input voltage	U1n	230VAC	
Rated frequency		50Hz	
Rated output voltage	U2n	8, 12, 24VAC	
Rated output current	I2n	1.5A / 1A / 0,5A	3A / 2A / 1A
Rated output power	Pn	12VA	24VA
Power loss	Pdis	1,5W	3W
Isolation class		Class II	
Service period		Continuous	
On/off switch		Yes	
Temperature protection		Yes	
Short-circuit protection		Yes	
Ambient operational temperature		0°C + 40°C	
Isolation material		PA	
Flammability class		V0	
Colors		Grey	

Mechanical parameters		BTR-12	BTR-24
Device width		36mm	54mm
Device height		85mm	85mm
Device depth		64mm	64mm
Mounting		Easy fastening onto 35mm device rail (DIN)	
Degree of protection		IP20	
Minimum cross section solid		0.75 mm <sup>2</sup>	
Maximum cross section solid		6 mm <sup>2</sup>	
Minimum cross section stranded		0,75 mm <sup>2</sup>	
Maximum cross section stranded		4 mm <sup>2</sup>	
Torque		1.2 Nm	
Terminals		Screw	
Storage temperature		-25°C + 70°C	
Humidity		95%	
Pollution degree		3	
Weight		0,356 kg	0,660 kg



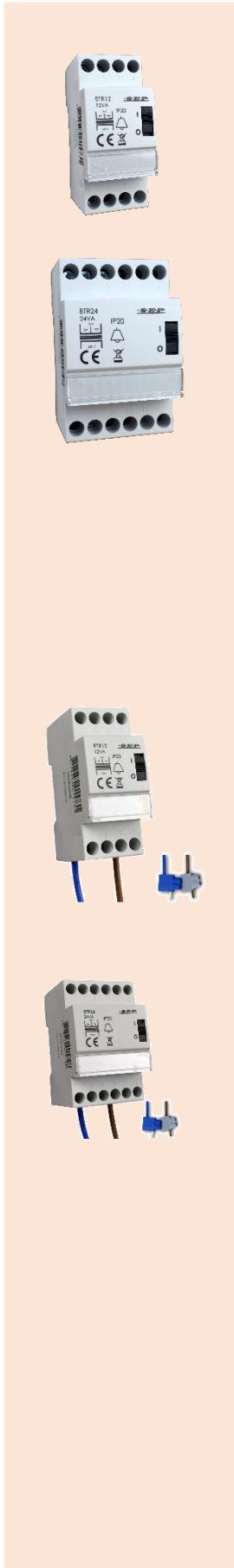

**Bell transformers**

Pn(VA)

12VA

24VA

**Order code**

**Standard**

**2114120005**

BTR-12

**2114120024**

BTR-24

**Bell transformer-packs**

12VA

Including connection materials

**2114120005**

BTR-12

24VA

Including connection materials

**2114120024**

BTR-24



**General**

The SEP CWCD and iWCD sockets are specifically designed to simplify service, maintenance, and diagnostic tasks of cabinets. The sockets come standard with child protection features, making them safe for use in non-industrial environments. The range includes additional types, such as sockets with power indicators, lids, and voltage displays, providing a comprehensive range of options. The sockets are highly flexible in terms of mounting, as they can be mounted on a din-rail, screwed in, or glued onto a mounting plate. These features make the SEP CWCD and iWCD sockets an efficient and versatile choice for a wide range of applications.



**General parameters**

Suitable for use in households, utilities, and industrial applications

**Electrical parameters**

Tested according		VDE 0620-1
Rated operational voltage	Un	250VAC
Rated operational current	In	16A
Rated frequency		50/60Hz
Version		Grounded
Ambient operational temperature		-20°C + 60°C
Contact material		CuZn37
Isolation material		PA
Flammability class		V0
Rated impulse withstand	Uimp	5000V
Rated insulation voltage	Ui	500V
Dielectric test voltage freq (1min)		2.8kV
Colors		Grey / Yellow
Children protection		Yes
Status indicator		Available on CWCD-GI, CWCD-GIY, iWCD-#
Protective lid		Available on iWCD-G#
Voltage display		Available on iWCD-GD and CWCD-GDY

**Mechanical parameters**

Device width	Single	44.5mm
	Double	89.5mm
Device height		75.5mm
Device depth		64mm
Mounting		Easy fastening onto 35mm device rail (DIN) Screw / Glue on mounting plate
Degree of protection		IP20
Minimum cross section solid		0.2 mm <sup>2</sup>
Maximum cross section solid		4 mm <sup>2</sup>
Minimum cross section stranded		0.2 mm <sup>2</sup>
Maximum cross section stranded		2.5 mm <sup>2</sup>
Terminals		Screw
Installation class		III
Storage temperature		-25°C + 70°C
Pollution degree		2
Weight	CWCD	0,10 kg
	CWCD-2	0,17 kg
	iWCD	0,08 kg

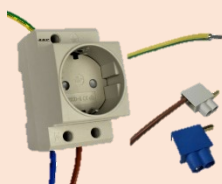

		Order code			
		Grey		Yellow	
<b>Single sockets</b>					
German					
Standard		<b>2114100012</b>	CWCD-1G	<b>2114100011</b>	CWCD-GY
With power indicator		<b>2114100050</b>	CWCD-GI	<b>2114100051</b>	CWCD-GIY
With lid and power indicator		<b>2114100030</b>	iWCD-G	<b>2114100031</b>	iWCD-GY
With voltage display, lid and power indicator		<b>2114100040</b>	iWCD-GD	<b>2114100041</b>	iWCD-GDY
<b>Double sockets</b>					
German					
Standard		<b>2114100020</b>	CWCD-2G	<b>2114100021</b>	CWCD-2GY
<b>Single sockets</b>					
French					
Standard		<b>2114100015</b>	CWCD-F		
<b>Socket - packs</b>					
Single socket	Including connection materials	<b>3910900020</b>	S-WCD+		



#### General

The LND-10 is a versatile emergency light that is designed to automatically turn on in the event of a power outage. It is compatible with both German and French style household sockets, and can be easily removed and used as a handheld torch to navigate in the dark. Additionally, the LND-10 can be installed in your distribution board, ensuring that you always have a reliable source of light during maintenance and service activities. Special combination packs are available to make installation even easier.



#### General parameters

Suitable for use in households, utilities, and industrial applications

#### Electrical parameters

Tested according	EN60598-1
Type	Emergency socket light / torch
Testing	Manual
Emergency	Decentralized
Switching type	Continuous / emergency
Autonomous	2 hour
On/off switch	Yes
Rated input voltage	230VAC
Rated frequency	50/60Hz
Lamp type	LED
Lamp numbers	1
Lamp power	1W
Lamp voltage	3V-3.4V
Lamp current	20mA
Light effective stream	20lm (IEC 62722-2-1)
Battery	Ni-MH
Battery voltage	3.7V / 90mAh
Battery service time	4.5hr
Battery charging time	6hrs
Service of life	500 cycles (IF NOT DEPLETED)
Ambient operational temperature	0°C + 40°C (daily average < 35°C)
Isolation material	PA66
Flammability class	V0
Colors	Grey / Transparent

#### Mechanical parameters

Device width	44mm
Device height	45mm
Device depth	34mm (53mm including plug)
Mounting	Outlet (German / French)
Degree of protection	IP20
Storage temperature	-25°C + 70°C
Pollution degree	3
Weight	0,056 kg



Emergency light	Order code	
	Standard	
LND10	2114120005	LND-10
<b>Emergency light-packs (including connection materials)</b>		
Single socket with emergency light	3910900021	LND-WCD1
Double socket with emergency light	3910900022	LND-WCD2



#### General

The SEP CPTS is an electronic time switch that can be used for everyday tasks like; illumination of private and industrial areas, street and shop-window lighting, regulation of air conditioning, flushing, motors, pumps, plants and machinery as well as to simulate presence etc. The time switch has a daily and weekly program and has automatic time correction (+/- 30sec weekly).



#### General parameters

Suitable for use in households, utilities, and industrial applications

#### Electrical parameters

Tested according		
Nominal voltage	Un	230VAC
Rated frequency		50/60Hz
Voltage range		85 ~ 110%
Display		LCD
Channels		1
Contact		1 Change-over
Contact load capacity	COS $\phi$ =1	16A
	COS $\phi$ =0.6	10A
Maximum load	P	2000W
Day program		Yes
Week program		Yes
Year program		No
Holiday program		No
Hysteresis		< +2 sec/day (25°C)
Pulse program		18 pulse programs (1s~59m59s)
Cycles program		16 on / off
Astro program		No
Controlled		Quartz
Switching interval		1 min
Time correction		-30 sec $\leq \Delta t \leq$ 30 sec
Battery reserve		3 years (lithium battery)
Power loss	Pdis	$\leq$ 5VA
Ambient operational temperature		-10°C ~ + 50°C
Isolation material		PA
Flammability class		V0

#### Mechanical parameters

Device width		36mm
Device height		86.5mm
Device depth		65.5mm
Mounting		Easy fastening onto 35mm device rail (DIN)
Degree of protection		IP20
Installation class		II
Minimum cross section solid		0.2 mm <sup>2</sup>
Maximum cross section solid		6 mm <sup>2</sup>
Minimum cross section stranded		0.2 mm <sup>2</sup>
Maximum cross section stranded		4 mm <sup>2</sup>
Terminals		Screw
Storage temperature		-20°C + 60°C
Pollution degree		2
Weight		0,15 kg

**Order code**

**Weekly timer**

1CO 2000W

**Standard**

114140010 CPTS





**General**

The SEP OVB serves as a common surge protective device that safeguards against overvoltage. By diverting surge energy to earth, the surge protector prevents high voltage from reaching and damaging devices. Additionally, electrical installation cables receive protection through this process.



**General parameters**

Suitable for use in households, utilities, and industrial applications

**Electrical parameters**

	Class I	Class II	Class III	Class I+II
Tested accordingly	EN/IEC 61643-11			
Nominal voltage	230/400V	230/400V	230V	230/400V
Maximum continuous voltage	280V	280V	280V	280V
U max AC	280V	280V	280V	280V
U max DC	255V	255V	255V	255V
Nominal discharge surge current (8/20 μs)	30kA	20kA	5kA	60kA
Nominal discharge surge current (8/20 μs) [L-N]	30kA	20kA	5kA	60kA
Maximum discharge surge current (8/20 μs)	60kA	40kA	10kA	100kA
Protection level	<1,5kV	<1.2kV	<1kV	<2kV
Response time	<25 ns	<25 ns	<25 ns	
Maximum backup fuse	125A			160A
Temperature range	-25 - + 40°C (daily average <35°C)			
Poles designation	2p / 4p			
Signal contact	Yes			

**Mechanical parameters**

Device width	2p	36mm   (54mm – Class I+ II / 18mm – Class III
	4p	72mm   108mm – Class I+II
Device height	86.5mm	
Device depth	65.5mm	
Mounting	Easy fastening onto 35mm device rail (DIN)	
Installation class	II	
Minimum cross section solid	4 mm <sup>2</sup>	
Maximum cross section solid	50 mm <sup>2</sup>	
Minimum cross section stranded	2,5 mm <sup>2</sup>	
Maximum cross section stranded	35 mm <sup>2</sup>	
Terminals	Screw	
Storage temperature	-20°C + 60°C	
Protection degree	IP20	
Pollution degree	2	



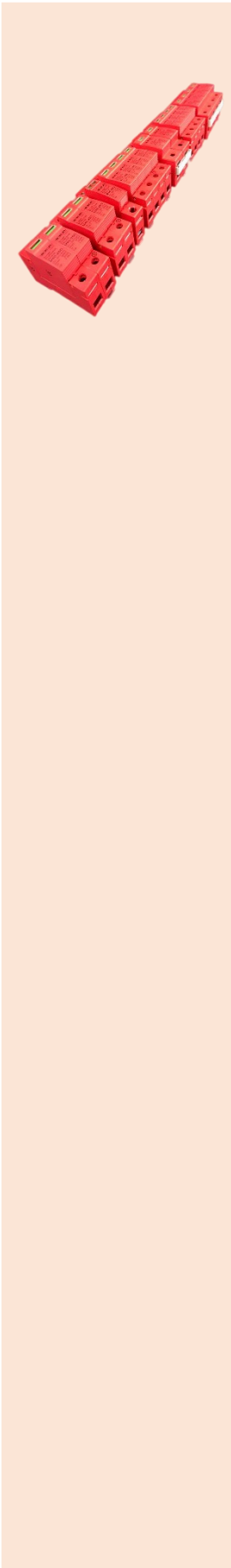

**Order code**

Weekly timers Class type		Order code			
		2p		4p	
1 (I)	(type B)	<b>2117002001</b>	SPD-M60-2SC	<b>2117004001</b>	SPD-M60-4SC
2 (II)	(type C)	<b>2117002002</b>	SPD-M40-2SC	<b>2117004002</b>	SPD-M40-4SC
3 (III)	(type D)	<b>2117002003</b>	SPD-M10-2SC		
1+2 (I+II)	(type B+C)	<b>2117002012</b>	SPD-M100-2SC	<b>2117004012</b>	SPD-M100-4SC



#### General

The SHC modular contactor is designed for AC 50/60Hz systems up to 400V and rated circuit currents up to 63A. It is ideal for controlling low-inductance loads in household applications and similar settings. The SHC modular contactor can also be utilized to regulate household motors, although the power output must be reduced accordingly.



#### General parameters

Suitable for use in households, utilities, and industrial applications
Noiseless and hum free
Spacer available when interior temperature of the enclosure is in range of 50°C

#### Electrical parameters

Tested according		IEC/EN 61095
Rated operational voltage		250VAC (2p) / 400VAC (4p)
Rated frequency	Ue	50/60Hz
Pole designations		2NO, 1NO/1NC, 2NC, 4NO, 3NO/1NC, 4NC, 2NO/2NC
Rated current		25A, 40A, 63A
Utilization category	In	AC-7a / AC-7b
Rated impulse withstand		2,5 kV (4kV for 12/24/48VAC)
Rated insulation voltage	Uimp	500V
Dielectric test voltage	Ui	2.5 kV
Mechanical life time		1.000.000 operation cycles
Electrical life time		100.000 operation cycles
Maximum operation switching a day		100 operation cycles

#### Mechanical parameters

Device width	M25	18mm – 2p / 36mm – 4p
	M40/M63	36mm – 2p / 54mm – 4p
Device depth		85mm
Device depth		73mm
Mounting		Easy fastening onto 35mm device rail (DIN)
Degree of protection (all sides)		IP40
Degree of protection (connection terminals)		IP20
Connection possibility		Cable
Terminals		Cage clamp terminal
Terminal capacity of control		1,5 – 2,5mm <sup>2</sup> / 2x 1,5mm <sup>2</sup> (rigid)
		1,5 – 2,5mm <sup>2</sup> / 2x 2,5mm <sup>2</sup> (flexible or ferrule)
Terminal capacity of power	16-25A	1,5 – 6mm <sup>2</sup> (rigid) – 1-4mm <sup>2</sup> (flexible or ferrule)
	40-63A	6 – 25mm <sup>2</sup> (rigid) – 6-16mm <sup>2</sup> (flexible or ferrule)
Fastening torque of control (A1 – A2)		0.8 Nm
Fastening torque of power		0.8 Nm (16-25A), 3.5Nm (40-63A)
Storage temperature		-40°C + 70°C
Ambient temperature		-5°C + 60°C (with daily average < 35°C)
Resistance to humidity and heat		Class 2
Installation class		III
Pollution degree		2



**Installation contactors 25A (AC-7a), 9A (AC-7b)**

Contact designation

Contact designation	230VAC		24VAC	
	Order code	SHC-M	Order code	SHC-M
2NO	3103000010	SHC-M2520	3103000190	SHC-M2520a
1NO/1NC	3103000020	SHC-M2511	3103000200	SHC-M2511a
2NC	3103000030	SHC-M2502	3103000210	SHC-M2502a
4NO	3103000040	SHC-M2540	3103000220	SHC-M2540a
4NC	3103000050	SHC-M2504	3103000230	SHC-M2504a
2NO/2NC	3103000060	SHC-M2522	3103000240	SHC-M2522a
3NO/1NC	3103000070	SHC-M2531	3103000250	SHC-M2531a



**Installation contactors 40A (AC-7a), 18A (AC-7b)**

Contact designation

Contact designation	230VAC		24VAC	
	Order code	SHC-M	Order code	SHC-M
2NO	3103000080	SHC-M4020	3103000260	SHC-M4020a
1NO/1NC	3103000090	SHC-M4011	3103000270	SHC-M4011a
2NC	3103000100	SHC-M4002	3103000280	SHC-M4002a
4NO	3103000110	SHC-M4040	3103000290	SHC-M4040a
4NC	3103000120	SHC-M4004	3103000300	SHC-M4004a
2NO/2NC	3103000130	SHC-M4022	3103000310	SHC-M4022a
3NO/1NC	3103000140	SHC-M4031	3103000320	SHC-M4031a



**Installation contactors 63A (AC-7a), 25A (AC-7b)**

Contact designation

Contact designation	230VAC		24VAC	
	Order code	SHC-M	Order code	SHC-M
4NO	3103000150	SHC-M6340	3103000330	SHC-M6340a
4NC	3103000160	SHC-M6304	3103000340	SHC-M6304a
2NO/2NC	3103000170	SHC-M6322	3103000350	SHC-M6322a
3NO/1NC	3103000180	SHC-M6331	3103000360	SHC-M6331a



**SHC-M Accessories**

1NO/1NC	3103000001	SHC-AUC11		
2NO	3103000002	SHC-AUC20		
Spacer	2119000010	CSP		





**General**

The SHC-P modular contactor is designed for AC 50/60Hz systems up to 400V and rated circuit currents of 16A. These contactors are commonly used in buildings to switch and control lighting, heating, ventilation, and pumps. As part of SEP's comprehensive line of DIN-rail products, the SHC-P modular contactor can be easily integrated into specialized panels.



**General parameters**

Suitable for use in households, utilities, and industrial applications
Noiseless and hum free
Spacer available when interior temperature of the enclosure is in range of 50°C

**Electrical parameters**

Tested according		IEC/EN 60669-2-2
Rated operational voltage	Ue	250VAC
Rated frequency		50/60Hz
Pole designations		2NO, 1NO/1CO, 1CO, 4NO, 3NO/1NC, 2NO/2NC, 2CO
Operation voltage	Un	230VA-110VDC / 48VAC-24VDC / 24VAC-12VDC
Operation threshold		85% of Un
Duration of the control		50ms to 1s (200ms recommended)
Response time		50ms
Rated current	In	16A
Utilization category		AC21 / AC22
Rated impulse withstand	Uimp	6 kV
Rated insulation voltage	Ui	440V
Dielectric test voltage		2.5 kV
Endurance	AC21	200.000 cycles
	AC22	100.000 cycles
Maximum operation switching a day		100 cycles
Maximum number of switching min		5 cycles
Power dissipation (impulse only)		19VA

**Mechanical parameters**

Device width		18mm (2p) / 36mm (4p)
Device height		85mm
Device depth		72mm
Mounting		Easy fastening onto 35mm device rail (DIN)
Degree of protection (all sides)		IP40
Degree of protection (connection terminals)		IP20
Connection possibility		Cable
Terminals		Cage clamp terminal
Terminal capacity of control		0,5 – 4mm <sup>2</sup> (rigid)
		1- 4mm <sup>2</sup> (flexible or ferrule)
Terminal capacity of control		1,5 – 4mm <sup>2</sup> (rigid)
		1,5 – 4mm <sup>2</sup> (flexible or ferrule)
Fastening torque of control (A1 – A2)		1 Nm
Fastening torque of power		1 Nm
Storage temperature		-40°C + 70°C
Ambient temperature		-5°C + 60°C (with daily average < 35°C)
Resistance to humidity and heat		Class 2
Installation class		III
Pollution degree		3

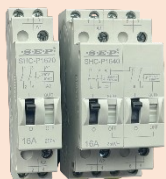

**230VAC / 110VDC Impulse contactors**

Contact designation

Contact designation	Order code	
2NO	3103100010	SHC-P1620
1NO/1NC	3103100020	SHC-P1611
1CO	3103100030	SHC-P16C1
4NO	3103100040	SHC-P1640
3NO/1NC	3103100050	SHC-P1631
2NO/2NC	3103100060	SHC-P1622
2CO	3103100070	SHC-P16C2

**24VAC / 12VDC Impulse contactors**

Contact designation

2NO	3103100080	SHC-P1620a
1NO/1NC	3103100090	SHC-P1611a
1CO	3103100100	SHC-P16C1a
4NO	3103100110	SHC-P1640a
3NO/1NC	3103100120	SHC-P1631a
2NO/2NC	3103100130	SHC-P1622a
2CO	3103100140	SHC-P16C2a

**48VAC / 24VDC Impulse contactors**

Contact designation

2NO	3103100150	SHC-P1620b
1NO/1NC	3103100160	SHC-P1611b
1CO	3103100170	SHC-P16C1b
4NO	3103100180	SHC-P1640b
3NO/1NC	3103100190	SHC-P1631b
2NO/2NC	3103100200	SHC-P1622b
2CO	3103100210	SHC-P16C2b

**SHC-M Accessories**

Spacer	2119000010	CSP
--------	------------	-----





## ***BUSBAR SYSTEMS***

## **Busbar Systems**

**4.03 – 4.39**

P	-	Closed busbar systems 10mm <sup>2</sup> PIN type 17,8mm	(63/100A)	03 – 06
P-G2	-	Closed busbar systems 10mm <sup>2</sup> PIN type 9 / 17,8mm	(63/100A)	07 – 11
F	-	Closed busbar systems 10mm <sup>2</sup> FORK type 17,8mm	(63/100A)	12 - 16
16P	-	Closed busbar systems 16mm <sup>2</sup> PIN type 17,8mm	(80/125A)	17 – 22
16P-G2	-	Closed busbar systems 16mm <sup>2</sup> PIN type 9 / 17,8mm	(80/125A)	23
16F	-	Closed busbar systems 16mm <sup>2</sup> FORK type 17,8mm	(80/125A)	24 - 28
30F	-	Closed busbar systems 30mm <sup>2</sup> FORK type 17,8mm	(125/210A)	29 – 30
		Connection terminals (MCB/RCCB/RCBO)		31 – 39



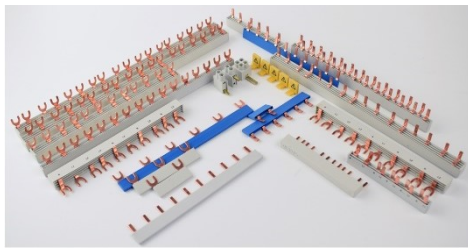

**General**  
 The SEP insulated busbar system is designed for connecting modular components, providing a reliable and efficient connection, reducing failures and enhancing heat management in the cabinet. When combined with accessories, the use of busbars can significantly decrease wiring within the cabinet, improving the overall appearance and clarity of the system.



**General parameters**

Insulated busbar
No cutting is necessary as the material is already at the required length
Wide range of busbars
Wide range of connection accessories

**Technical parameters**

Complies with	IEC 60439-1   2000-08
According	IEC 664
Busbar material	E-Cu-ETP
Isolation material	Ultramid PA6 glass fiber reinforced
Form test	125°C (after 1,8MPa)
Glow wire test	960°C according IEC60895-2-12
Flammability class	V0
Tracking index	550
Short circuit strength	25kA / 100A gl
Disruptive strength	36kV / mm
Climate stability	IEC 68-2
Operating voltage	500V AC
Surge voltage	4kV
Isolation group	According VDE 0110-T1
Overtoltage category	III
Degree of soiling	2
Halogen free	According DIN EN 50267-2-2
Colors	Related to RAL7035 and RAL5015 (grey/blue)
Type	PIN and FORK
Cross section	10mm <sup>2</sup>
Max. current one side line-in	63A
Max. current central line-in	100A*

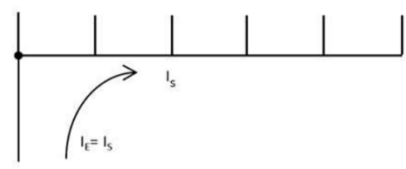

ONE SIDE LINE-IN

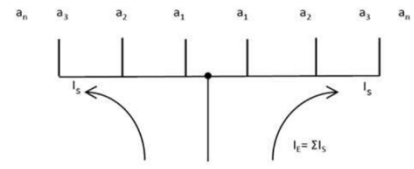

CENTRAL LINE-IN

\* The Is is rated on an equal divided demand on both sides of the feeding-main (line-in) of the busbar the sum of the equal divided output current cannot be higher than the busbar current (Is)

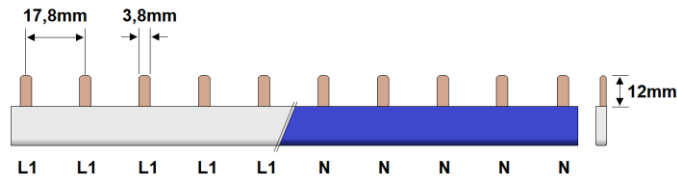

Order code

1 Phase Busbar PIN			Grey		Blue	
number of poles	Length	Module width				
2	2x 1p	30 mm (2MU)	2305101002	P01002G00	2305101902	P01002B00
3	3x 1p	45 mm (3MU)	2305101003	P01003G00	2305101903	P01003B00
4	4x 1p	64 mm (4MU)	2305101004	P01004G00	2305101904	P01004B00
5	5x 1p	79 mm (5MU)	2305101005	P01005G00	2305101905	P01005B00
6	6x 1p	103 mm (6MU)	2305101006	P01006G00	2305101906	P01006B00
7	7x 1p	121 mm (7MU)	2305101007	P01007G00	2305101907	P01007B00
8	8x 1p	139 mm (8MU)	2305101008	P01008G00	2305101908	P01008B00
9	9x 1p	156 mm (9MU)	2305101009	P01009G00	2305101909	P01009B00
10	10x 1p	172 mm (10MU)	2305101010	P01010G00	2305101910	P01010B00
11	11x 1p	189 mm (11MU)	2305101011	P01011G00	2305101911	P01011B00
12	12x 1p	206 mm (12MU)	2305101012	P01012G00	2305101912	P01012B00
13	13x 1p	224 mm (13MU)	2305101013	P01013G00	2305101913	P01013B00

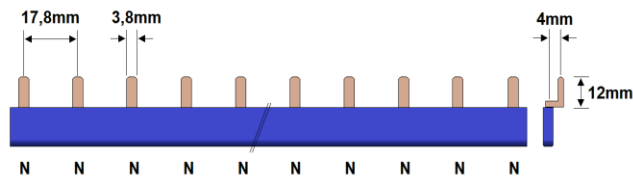

Order code

1 Phase Busbars PIN			Grey		Blue	
number of poles	Length	Module width				
2	2x 1p	30 mm (2MU)			2305101992	P01002B10
3	3x 1p	45 mm (3MU)			2305101993	P01003B10
4	4x 1p	64 mm (4MU)			2305101994	P01004B10
5	5x 1p	79 mm (5MU)			2305101995	P01005B10
6	6x 1p	103 mm (6MU)			2305101996	P01006B10
8	8x 1p	139 mm (8MU)			2305101998	P01008B10
10	10x 1p	172 mm (10MU)			2305101990	P01010B10
12	12x 1p	206 mm (12MU)			2305101991	P01012B10

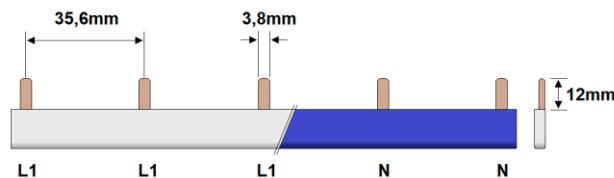

Order code

1 Phase Busbars PIN			Grey		Blue	
number of poles	Length	Module width				
2	2x 1p	45 mm (3MU)	2305171002	P01102G00	2305171902	P01102B00
3	3x 1p	79 mm (5MU)	2305171003	P01103G00	2305171903	P01103B00
4	4x 1p	121 mm (7MU)	2305171004	P01104G00	2305171904	P01104B00
5	5x 1p	156 mm (9MU)	2305171005	P01105G00	2305171905	P01105B00
6	6x 1p	189 mm (11MU)	2305171006	P01106G00	2305171906	P01106B00

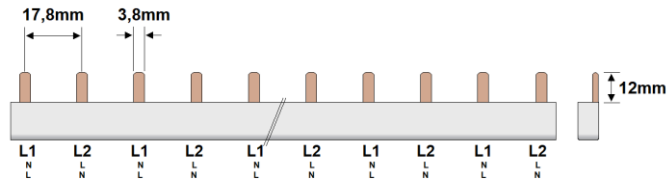

Order code

2 Phase Busbars PIN		Length	Module width	Order code	
number of poles					
4	2x 2p	72 mm	(4MU)	2305102004	P02004G00
6	3x 2p	104 mm	(6MU)	2305102006	P02006G00
8	4x 2p	139 mm	(8MU)	2305102008	P02008G00
10	5x 2p	174 mm	(10MU)	2305102010	P02010G00
12	6x 2p	210 mm	(12MU)	2305102012	P02012G00
14	7x 2p	248 mm	(14MU)	2305102014	P02014G00
16	8x 2p	286 mm	(16MU)	2305102016	P02016G00
18	9x 2p	324 mm	(18MU)	2305102018	P02018G00

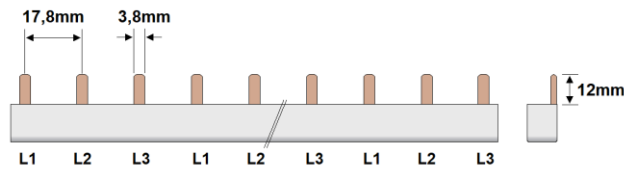

Order code

3 Phase Busbars PIN		Length	Module width	Order code	
number of poles					
6	2x 3p	107 mm	(6MU)	2305103006	P03006G00
9	3x 3p	160 mm	(9MU)	2305103009	P03009G00
12	4x 3p	211 mm	(12MU)	2305103012	P03012G00
15	5x 3p	267 mm	(15MU)	2305103015	P03015G00
18	6x 3p	317 mm	(18MU)	2305103018	P03018G00

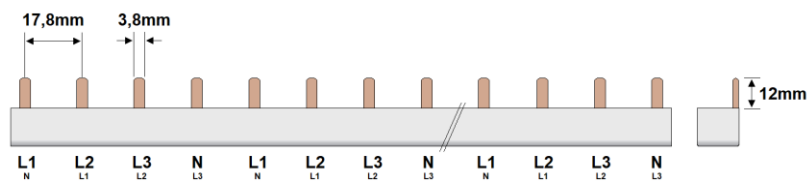

Order code

4 Phase Busbars PIN		Length	Module width	Order code	
number of poles					
8	2x 4p	140 mm	(8MU)	2305104008	P04008G00
12	3x 4p	211 mm	(12MU)	2305104012	P04012G00
16	4x 4p	284 mm	(16MU)	2305104016	P04016G00

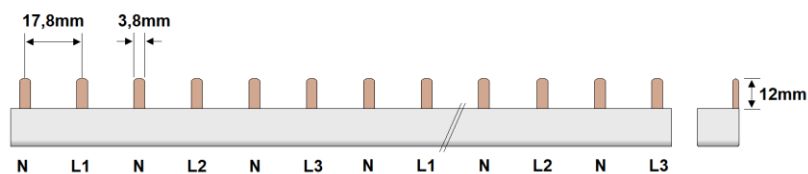

Order code

3+N Phase Busbar PIN		Length	Module width	Order code	
number of poles					
12	6x 2p	211 mm	(12MU)	2305105012	P04012G50
18	9x 2p	317 mm	(18MU)	2305105018	P04018G50

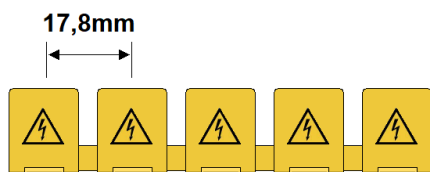

Order code

Busbar protection covers  
breakable

number of poles	Busbar type	Cross section
5x 1p	PIN and FORK	10-16mm <sup>2</sup>

2115900010 IK



Order code

Direct connection terminals for busbar

Conductor diameter (mm <sup>2</sup> )		Busbar type	Cross section
Solid	Stranded		
6-50mm <sup>2</sup>	6-35mm <sup>2</sup>	PIN and FORK	10-16mm <sup>2</sup>

2115910050 BFT50

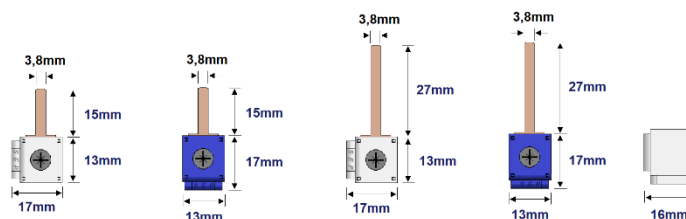

Connection terminals for busbars PIN

Order code

Cross section	Length connection	Connection way	Grey		Blue	
			Order code	Part number	Order code	Part number
1x25 mm <sup>2</sup>	15mm	Front	2115925011	SPR-G2515	2115925511	SPR-B2515
1x25 mm <sup>2</sup>	27mm	Front	2115925021	SPR-G2527	2115925521	SPR-B2527
1x25 mm <sup>2</sup>	15mm	Side	2115925012	SPS-G2515	2115925512	SPS-B2515
1x25 mm <sup>2</sup>	27mm	Side	2115925022	SPS-G2527	2115925522	SPS-B2527

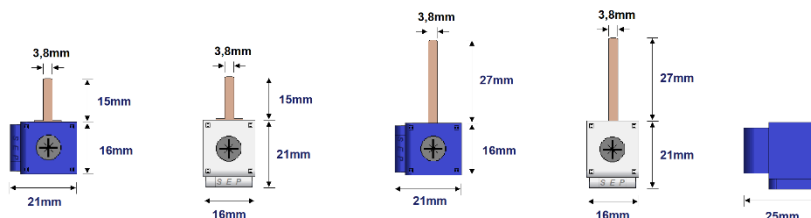

Connection terminals for busbars PIN

Order code

Cross section	Length connection	Connection way	Grey		Blue	
			Order code	Part number	Order code	Part number
1x50mm <sup>2</sup>	15mm	Front	2115950011	SPR-G5015	2115950511	SPR-B5015
1x50 mm <sup>2</sup>	27mm	Front	2115950021	SPR-G5027	2115950521	SPR-B5027
1x50 mm <sup>2</sup>	15mm	Side	2115950012	SPS-G5015	2115950512	SPS-B5015
1x50 mm <sup>2</sup>	27mm	Side	2115950022	SPS-G5027	2115950522	SPS-B5027

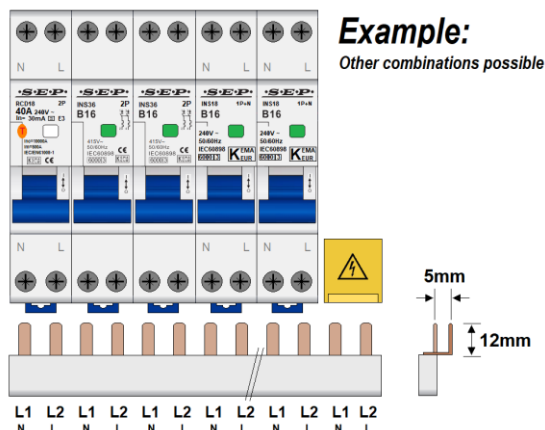

2 Phase Busbars PIN			Order code	
number of poles	Length	Module width		
6	3x 2p	(3MU)	2305122906	P02006G20
8	4x 2p	(4MU)	2305122908	P02008G20
10	5x 2p	(5MU)	2305122910	P02010G20
12	6x 2p	(6MU)	2305122912	P02012G20
16	8x 2p	(8MU)	2305122916	P02016G20
20	10x 2p	(10MU)	2305122920	P02020G20
24	12x 2p	(12MU)	2350122924	P02024G20

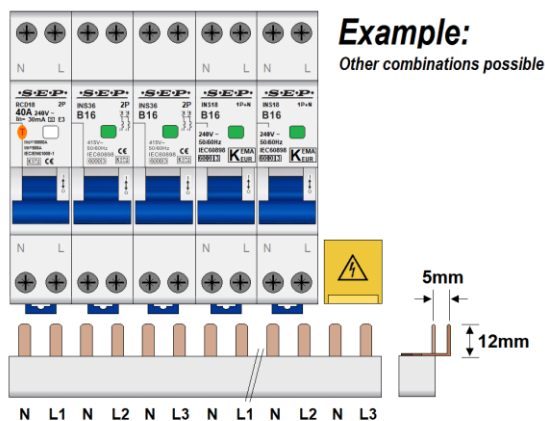

3+N Phase Busbars PIN			Order code	
number of poles	Length	Module width		
12	6x 2p	(6MU)	2305142912	P04012G20
18	9x 2p	(9MU)	2305142920	P04018G20
24	12x 2p	(12MU)	2305142924	P04024G20

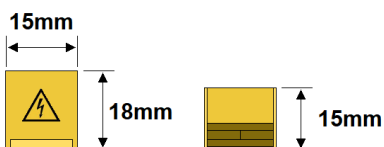

Busbar protection cover PIN			Order code	
number of poles	Busbar type	Cross section		
2	1x 2p	PIN (2p - 17,8mm)	2115900015	IK-D

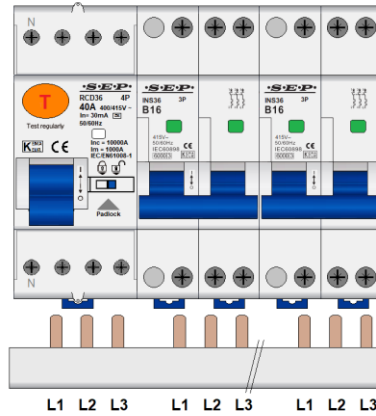

**Example:**  
Other combinations possible



4 Phase Busbars PIN			Order code
number of poles	Length	Module width	
6	2x 3p	(4MU)	2305142808 P03006G40
9	3x 3p	(6MU)	2305142812 P03009G40
12	4x 3p	(8MU)	2305142816 P03012G40
15	5x 3p	(10MU)	2305142820 P03015G40
18	6x 3p	(12MU)	2305142824 P03018G40

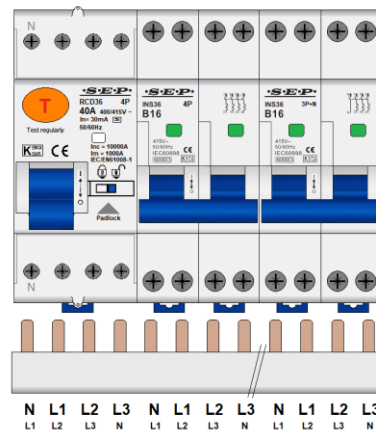

**Example:**  
Other combinations possible



4 Phase Busbars PIN			Order code
number of poles	Length	Module width	
8	2x 4p	(4MU)	2305142808 P04008G40
12	3x 4p	(6MU)	2305142812 P04012G40
16	4x 4p	(8MU)	2305142816 P04016G40
20	5x 4p	(10MU)	2305142820 P04020G40
24	6x 4p	(12MU)	2305142824 P04024G40

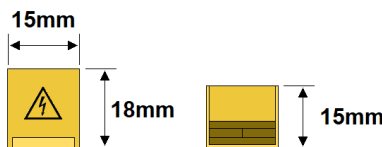

Busbar protection cover PIN			Order code
number of poles	Busbar type	Cross section	
2	1x 2p PIN (2p - 17,8mm)	10-16mm <sup>2</sup>	2115900015 IK-D

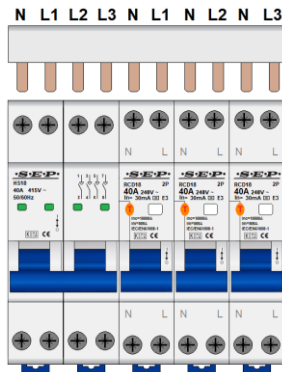

Order code

Combination busbar (N-L1-L2-L3-N-L1-N-L2-N-L3) PIN

number of poles	Length	Module	Order code	
10	1x 4p + 3x 2p	(5MU)	2305195910	P24010G20

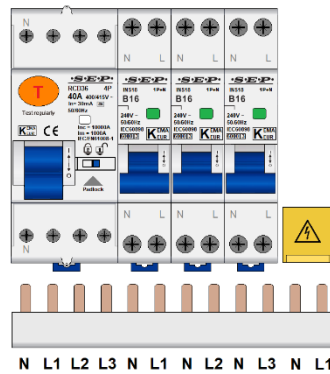

Order code

Combination busbar (N-L1-L2-L3-N-L1-N-L2-N-L3-N-L1) PIN

number of poles	Length	Module	Order code	
12	1x 4p + 4x 2p	(6MU)	2305194010	P14012G40

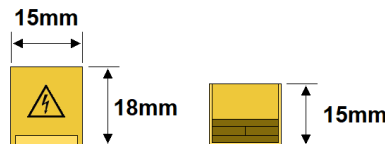

Order code

Busbar protection cover PIN

number of poles	Busbar type	Cross section	Order code	
2	1x 2p	PIN (2p - 17,8mm)	2115900015	IK-D

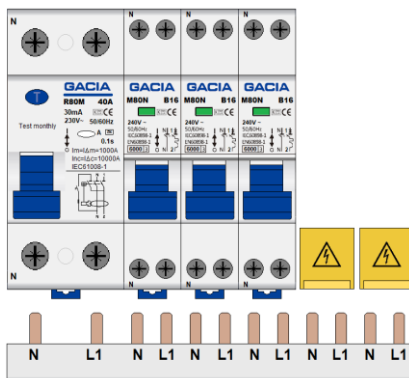

GACIA combination busbars (N-L1-N-L1...) PIN

number of poles	Length	Module	Order code	
6	1x 2p + 2x 2p	72 mm	(4MU)	2305192006 P12006G20
8	1x 2p + 3x 2p	88 mm	(5MU)	2305192008 P12008G20
10	1x 2p + 4x 2p	103 mm	(6MU)	2305192010 P12010G20
12	1x 2p + 5x 2p	122 mm	(7MU)	2305192012 P12012G20

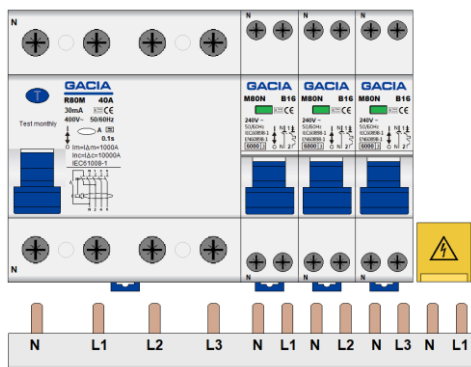

Combination busbar (N-L1-L2-L3-N-L1-N-L2-N-L3-N-L1) PIN

number of poles	Length	Module	Order code	
12	1x 4p + 4x 2p	141 mm	(8MU)	2305194012 P14012G20

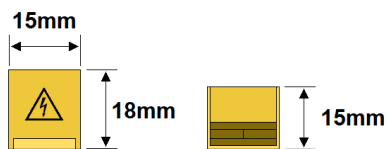

Busbar protection cover PIN

number of poles	Busbar type	Cross section	Order code	
2	1x 2p	PIN (2p - 17,8mm)	10-16mm <sup>2</sup>	2115900015 IK-D



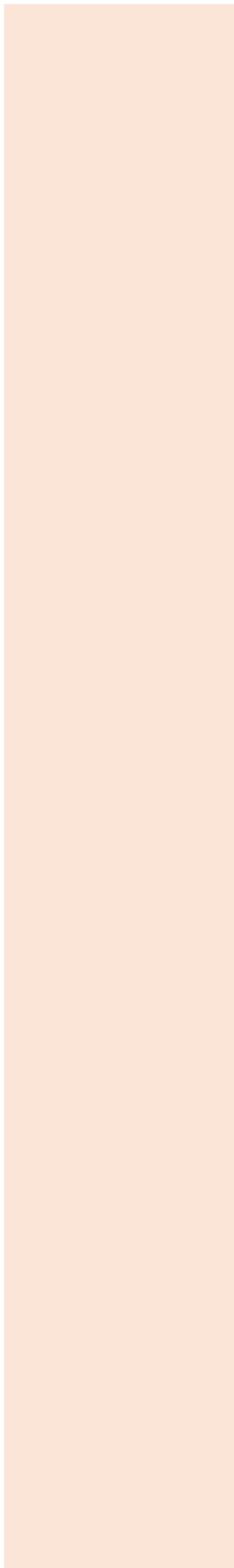

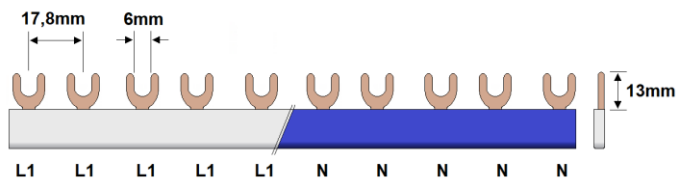

Order code

1 Phase Busbars FORK		Length	Module width	Grey		Blue	
number of poles							
2	2x 1p	30 mm	(2MU)	<b>2305111002</b>	F01002G06	<b>2305111902</b>	F01002B06
3	3x 1p	45 mm	(3MU)	<b>2305111003</b>	F01003G06	<b>2305111903</b>	F01003B06
4	4x 1p	64 mm	(4MU)	<b>2305111004</b>	F01004G06	<b>2305111904</b>	F01004B06
5	5x 1p	79 mm	(5MU)	<b>2305111005</b>	F01005G06	<b>2305111905</b>	F01005B06
6	6x 1p	103 mm	(6MU)	<b>2305111006</b>	F01006G06	<b>2305111906</b>	F01006B06
7	7x 1p	121 mm	(7MU)	<b>2305111007</b>	F01007G06	<b>2305111907</b>	F01007B06
8	8x 1p	139 mm	(8MU)	<b>2305111008</b>	F01008G06	<b>2305111908</b>	F01008B06
9	9x 1p	156 mm	(9MU)	<b>2305111009</b>	F01009G06	<b>2305111909</b>	F01009B06
10	10x 1p	172 mm	(10MU)	<b>2305111010</b>	F01010G06	<b>2305111910</b>	F01010B06
11	11x 1p	189 mm	(11MU)	<b>2305111011</b>	F01011G06	<b>2305111911</b>	F01011B06
12	12x 1p	206 mm	(12MU)	<b>2305111012</b>	F01012G06	<b>2305111912</b>	F01012B06
13	13x 1p	224 mm	(13MU)	<b>2305111013</b>	F01013G06	<b>2305111913</b>	F01013B06

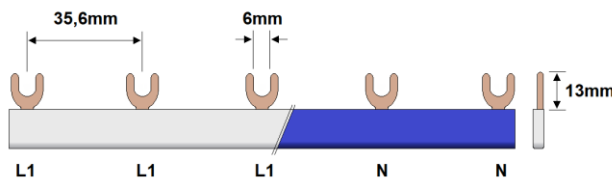

Order code

1 Phase Busbars FORK		Length	Module width	Grey		Blue	
number of poles							
2	2x 1p	45 mm	(3MU)	<b>2305181002</b>	F01102G06	<b>2305181903</b>	F01103B06
3	3x 1p	79 mm	(5MU)	<b>2305181003</b>	F01103G06	<b>2305181902</b>	F01102B06
4	4x 1p	121 mm	(7MU)	<b>2305181004</b>	F01104G06	<b>2305181904</b>	F01104B06
5	5x 1p	156 mm	(9MU)	<b>2305181005</b>	F01105G06	<b>2305181905</b>	F01105B06
6	6x 1p	189 mm	(11MU)	<b>2305181006</b>	F01106G06	<b>2305181906</b>	F01106B06

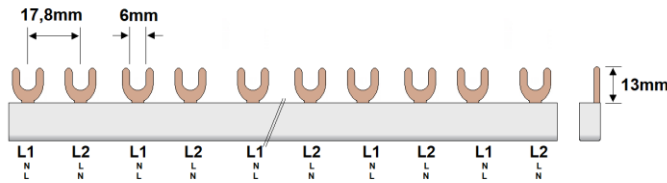

2 Phase Busbars FORK			Order code	
number of poles		Length	Module width	
4	2x 2p	72 mm	(4MU)	2305112004 F02004G06
6	3x 2p	104 mm	(6MU)	2305112006 F02006G06
8	4x 2p	139 mm	(8MU)	2305112008 F02008G06
10	5x 2p	174 mm	(10MU)	2305112010 F02010G06
12	6x 2p	210 mm	(12MU)	2305112012 F02012G06
14	7x 2p	248 mm	(14MU)	2305112014 F02014G06
16	8x 2p	286 mm	(16MU)	2305112016 F02016G06
18	9x 2p	324 mm	(18MU)	2305112018 F02018G06

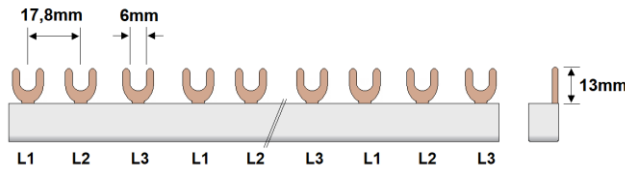

3 Phase Busbars FORK			Order code	
number of poles		Length	Module width	
6	2x 3p	107 mm	(6MU)	2305113006 F03006G06
9	3x 3p	160 mm	(9MU)	2305113009 F03009G06
12	4x 3p	211 mm	(12MU)	2305113012 F03012G06
15	5x 3p	267 mm	(15MU)	2305113015 F03015G06
18	6x 3p	317 mm	(18MU)	2305113018 F03018G06

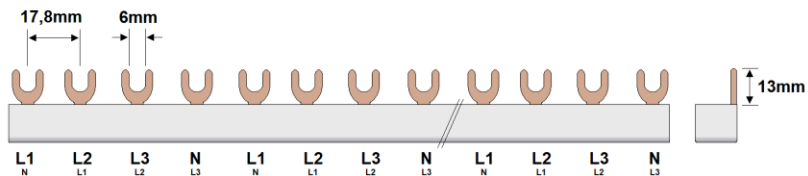

4 Phase Busbars FORK			Order code	
number of poles		Length	Module width	
8	2x 4p	140 mm	(8MU)	2305114008 F04008G06
12	3x 4p	211 mm	(12MU)	2305114012 F04012G06
16	4x 4p	284 mm	(16MU)	2305114016 F04016G06

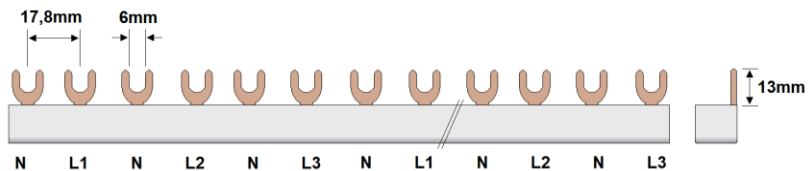

3+N Phase Busbar FORK			Order code	
number of poles		Length	Module width	
12	6x 2p	211 mm	(12MU)	2305115012 F04012G56
18	9x 2p	317 mm	(18MU)	2305115018 F04018G56

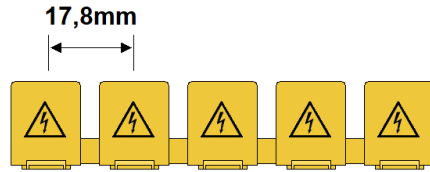

Order code

Busbar protection covers breakable

number of poles	Busbar type	Cross section	Order code
5	5x 1p	PIN and FORK	2115900010 IK



Order code

Direct connection terminal for busbar

Conductor diameter (mm <sup>2</sup> )	Busbar type	Cross section	Order code
Solid	PIN and FORK	10-16mm <sup>2</sup>	2115910050 BFT50
6-50mm <sup>2</sup>			
Stranded			
6-35mm <sup>2</sup>			

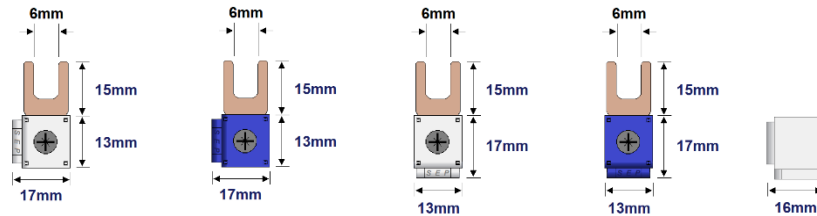

Order code

Connection terminals for busbar FORK

Cross section	Length connection	Connection way	Order code	
			Grey	Blue
1x25 mm <sup>2</sup>	15mm	Front	2115925031 SFR-G2515	2115925531 SFR-B2515
1x25 mm <sup>2</sup>	15mm	Side	2115925032 SFS-G2515	2115925532 SFS-B2515

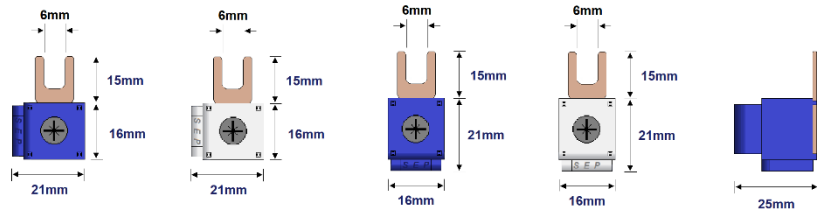

Order code

Connection terminals for busbar FORK

Cross section	Length connection	Connection way	Order code	
			Grey	Blue
1x50mm <sup>2</sup>	15mm	Front	2115950031 SFR-G5015	2115950531 SFR-B5015
1x50 mm <sup>2</sup>	15mm	Side	2115950032 SFS-G5015	2115950532 SFS-B5015

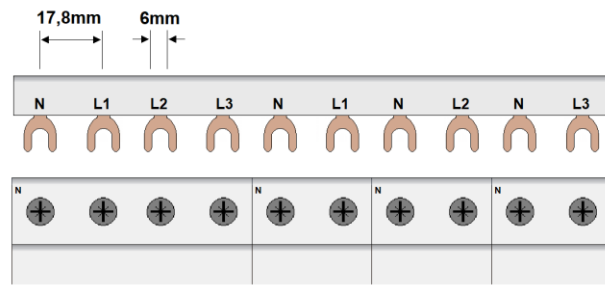

Order code

Combination busbar (N-L1-L2-L3-N-L1-N-L2-N-L3) FORK			Order code	
number of poles	Length	Module		
10	1x 4p + 3x 2p	(10MU)	2305195010	F14010G56

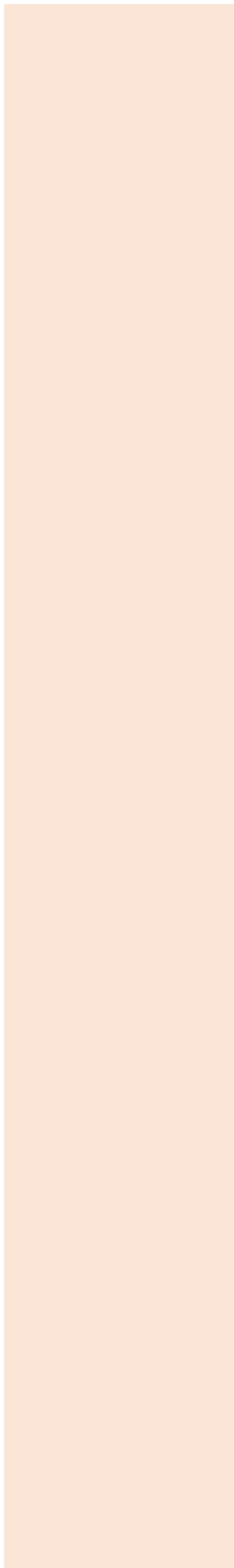



**General**

The SEP insulated busbar system, available in 1-meter length and 16mm<sup>2</sup> size, is used for connecting modular components. These busbars can be ordered in fixed lengths, saving valuable time. The use of busbars provides a reliable and efficient connection, reduces failures, and enhances heat management within the cabinet. When combined with accessories, wiring within the cabinet can be significantly reduced, resulting in a neat and clear system.



**General parameters**

- Insulated busbar in combination with endcap
- The busbar can be cut to the required size as needed
- Wide range of busbar
- Wide range of connection accessories

**Technical parameters**

Complies with	IEC 61439-1   2000-08
According	IEC 664
Busbar material	E-Cu-ETP
Isolation material	PC
Form test	90°C (after 1,8MPa)
Glow wire test	960°C according IEC60895-2-12
Flammability class	V0
Tracking index	550
Short circuit strength	25kA / 100A gl
Disruptive strength	35kV / mm
Climate stability	IEC 68-2
Operating voltage	500V AC
Surge voltage	4kV
Isolation group	According VDE 0110-T1
Overtoltage category	III
Degree of soiling	2
Halogen free	According DIN EN 50267-2-2
Colors	Related to RAL7035 and RAL5015 (grey/blue)
Type	PIN and FORK
Cross section	16mm <sup>2</sup>
Max. current one side line-in	80A
Max. current central line-in	125A*

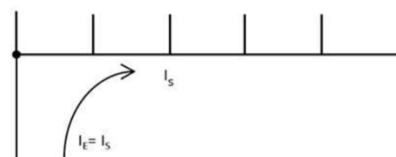

ONE SIDE LINE-IN

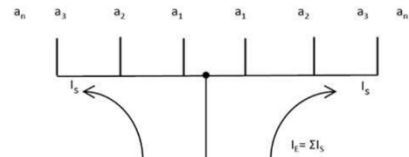

CENTRAL LINE-IN

\* The Is is rated on an equal divided demand on both sides of the feeding-main (line-in) of the busbar the sum of the equal divided output current cannot be higher than the busbar current (Is)

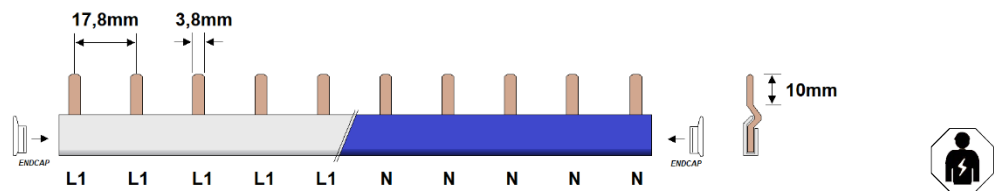

Order code

1 Phase Busbars		Length	Module width	Grey		Blue	
PIN	number of poles						
6	6x 1p	107 mm	(6MU)	2306010006	16P01006G00	2306019006	16P01006B00
9	9x 1p	160 mm	(9MU)	2306010009	16P01009G00	2306019009	16P01009B00
12	12x 1p	212 mm	(12MU)	2306010012	16P01012G00	2306019012	16P01012B00
15	15x 1p	267 mm	(15MU)	2306010015	16P01015G00	2306019015	16P01015B00
18	18x 1p	320 mm	(18MU)	2306010018	16P01018G00	2306019018	16P01018B00
21	21x 1p	374 mm	(21MU)	2306010021	16P01021G00	2306019021	16P01021B00
24	24x 1p	427 mm	(24MU)	2306010024	16P01024G00	2306019024	16P01024B00
54	54x 1p	1016 mm	(54MU)	<b>2306160100</b>	16P001G00	<b>2306160101</b>	16P001B00
Busbar endcap				<b>2306169011</b>	SVK1EC1	<b>2306169011</b>	SVK1EC1

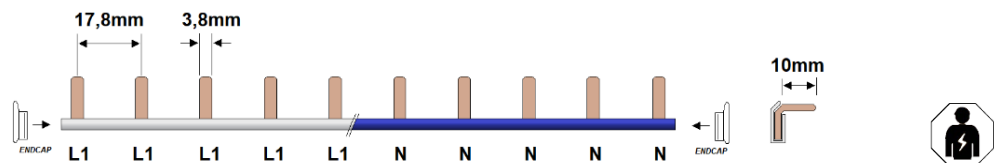

Order code

1 Phase Busbars		Length	Module width	Grey		Blue	
PIN	number of poles						
6	6x 1p	107 mm	(6MU)	2306010106	16P01006G90	2306019106	16P01006B90
9	9x 1p	160 mm	(9MU)	2306010109	16P01009G90	2306019109	16P01009B90
12	12x 1p	212 mm	(12MU)	2306010112	16P01012G90	2306019112	16P01012B90
15	15x 1p	267 mm	(15MU)	2306010115	16P01015G90	2306019115	16P01015B90
18	18x 1p	320 mm	(18MU)	2306010118	16P01018G90	2306019118	16P01018B90
21	21x 1p	374 mm	(21MU)	2306010121	16P01021G90	2306019121	16P01021B90
24	24x 1p	427 mm	(24MU)	2306010124	16P01024G90	2306019124	16P01024B90
54	54x 1p	1016 mm	(54MU)	<b>2306160110</b>	16P001G90	<b>2306160111</b>	16P001B90
Busbar endcap				<b>2306169010</b>	SVK1EC	<b>2306169010</b>	SVK1EC



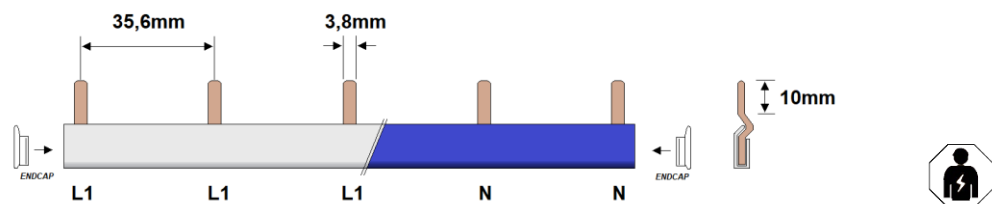

Order code

1 Phase Busbars PIN			Grey		Blue	
number of poles	Length	Module width				
6	2x 1p	212 mm (12MU)	2306010206	16P01106G00	2306019206	16P01106B00
9	3x 1p	320 mm (18MU)	2306010209	16P01109G00	2306019209	16P01109B00
12	4x 1p	427 mm (24MU)	2306010212	16P01112G00	2306019212	16P01112B00
27	5x 1p	1016 mm (54MU)	<b>2306160120</b>	16P011G00	<b>2306160121</b>	16P011B00
Busbar endcap			<b>2306169011</b>	SVK1EC1	<b>2306169011</b>	SVK1EC1

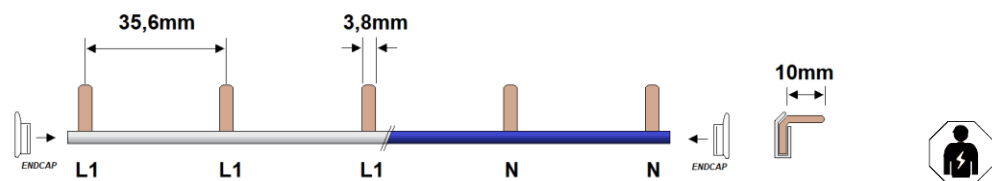

Order code

1 Phase Busbars PIN			Grey		Blue	
number of poles	Length	Module width				
6	2x 1p	212 mm (12MU)	2306010306	16P01106G90	2306019306	16P01106B90
9	3x 1p	320 mm (18MU)	2306010309	16P01109G90	2306019309	16P01109B90
12	4x 1p	427 mm (24MU)	2306010312	16P01112G90	2306019312	16P01112B90
27	5x 1p	1016 mm (54MU)	<b>2306160130</b>	16P011G90	<b>2306160131</b>	16P011B90
Busbar endcap			<b>2306169010</b>	SVK1EC	<b>2306169010</b>	SVK1EC

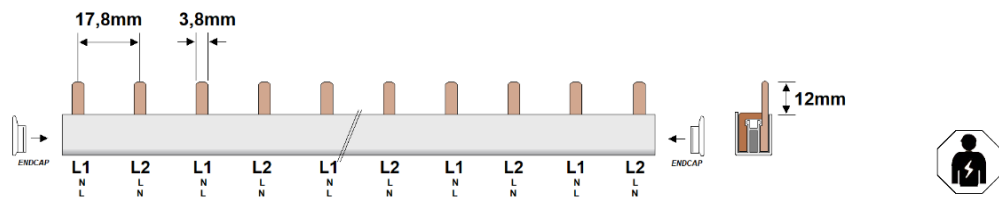

2 Phase Busbars PIN				Order code	
number of poles		Length	Module width		
6	3x 2p	107 mm	(6MU)	2306120006	16F02006G06
8	4x 2p	142 mm	(8MU)	2306120008	16F02008G06
10	5x 2p	178 mm	(10MU)	2306120010	16F02010G06
12	6x 2p	212 mm	(12MU)	2306120012	16F02012G06
14	7x 2p	249 mm	(14MU)	2306120014	16F02014G06
16	8x 2p	285 mm	(16MU)	2306120016	16F02016G06
18	9x 2p	320 mm	(18MU)	2306120018	16F02018G06
20	10x 2p	356 mm	(20MU)	2306120020	16F02020G06
22	11x 2p	392 mm	(22MU)	2306120022	16F02022G06
24	12x 2p	427 mm	(24MU)	2306120024	16F02024G06
54	27x 2p	1016 mm	(54MU)	<b>2306161200</b>	16F002G06
Busbar endcap				<b>2306169020</b>	SVK2EC

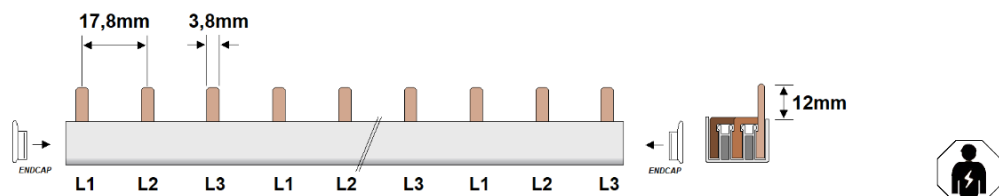

3 Phase Busbars PIN				Order code	
number of poles		Length	Module width		
6	2x 3p	107 mm	(6MU)	<b>2306130006</b>	16F03006G06
9	3x 3p	160 mm	(9MU)	<b>2306130009</b>	16F03009G06
12	4x 3p	212 mm	(12MU)	<b>2306130012</b>	16F03012G06
15	5x 3p	267 mm	(15MU)	<b>2306130015</b>	16F03015G06
18	6x 3p	320 mm	(18MU)	<b>2306130018</b>	16F03018G06
21	7x 3p	374 mm	(21MU)	<b>2306130021</b>	16F03021G06
24	8x 3p	427 mm	(24MU)	<b>2306130024</b>	16F03024G06
54	18x 3p	1016 mm	(54MU)	<b>2306161300</b>	16F003G06
Busbar endcap				<b>2306169030</b>	SVK3EC

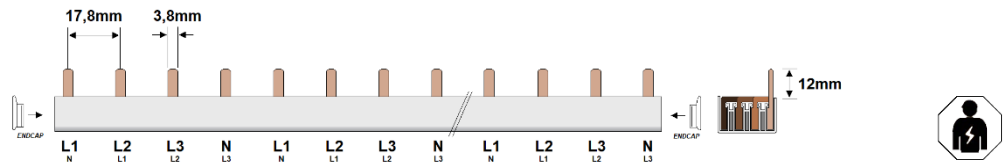

4 Phase Busbars PIN			Order code		
number of poles		Length	Module width		
8	2x 4p	142 mm	(8MU)	<b>2306040008</b>	16P04008G00
12	3x 4p	212 mm	(12MU)	<b>2306040012</b>	16P04012G00
16	4x 4p	285 mm	(16MU)	<b>2306040016</b>	16P04016G00
20	5x 4p	356 mm	(20MU)	<b>2306040020</b>	16P04020G00
24	6x 4p	427 mm	(24MU)	<b>2306040024</b>	16P04024G00
56	14x 4p	1016 mm	(56MU)	<b>2306160400</b>	16P004G00
Busbar endcap				<b>2306169040</b>	SVK4EC

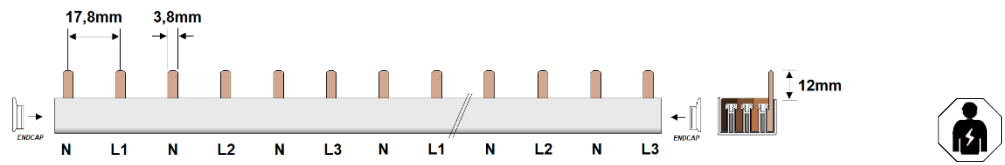

3+N Phase Busbars PIN			Order code		
number of poles		Length	Module width		
12	6x 2p	212 mm	(12MU)	<b>2306050012</b>	16P04012G50
18	9x 2p	320 mm	(18MU)	<b>2306050018</b>	16P04018G50
24	12x 2p	427 mm	(24MU)	<b>2306050024</b>	16P04024G50
56	28x 2p	1016 mm	(56MU)	<b>2306160500</b>	16P004G50
Busbar endcap				<b>2306169040</b>	SVK4EC

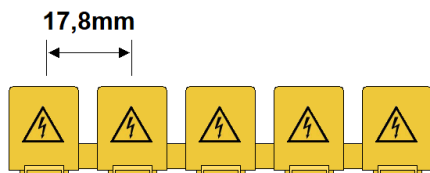

Order code

Busbar protection cover  
breakable

number of poles	Busbar type	Cross section	Order code	
5	5x 1p	PIN and FORK	10-16mm <sup>2</sup>	2115900010 IK



Order code

Direct connection terminal for busbar

Conductor diameter (mm <sup>2</sup> )		Busbar type	Cross section	Order code	
Solid	Stranded				
6-50mm <sup>2</sup>	6-35mm <sup>2</sup>	PIN and FORK	10-16mm <sup>2</sup>	2115910050	BFT50

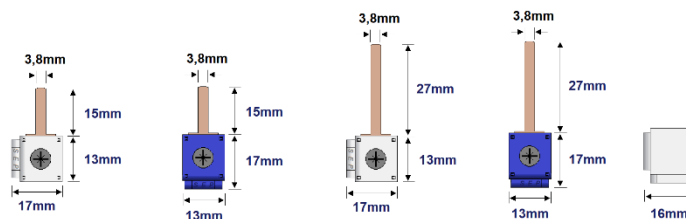

Connection terminals for busbar PIN

Order code

Cross section	Length connection	Connection way	Grey		Blue	
			Order code	Part number	Order code	Part number
1x25 mm <sup>2</sup>	15mm	Front	2115925011	SPR-G2515	2115925511	SPR-B2515
1x25 mm <sup>2</sup>	27mm	Front	2115925021	SPR-G2527	2115925521	SPR-B2527
1x25 mm <sup>2</sup>	15mm	Side	2115925012	SPS-G2515	2115925512	SPS-B2515
1x25 mm <sup>2</sup>	27mm	Side	2115925022	SPS-G2527	2115925522	SPS-B2527

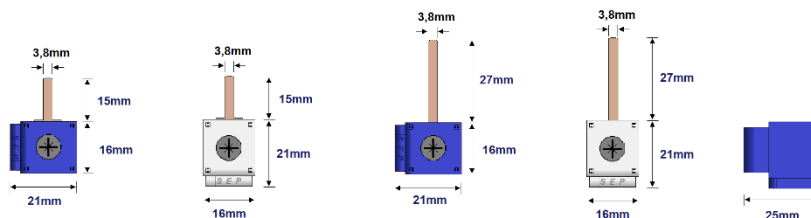

Connection terminals for busbar PIN

Order code

Cross section	Length connection	Connection way	Grey		Blue	
			Order code	Part number	Order code	Part number
1x50mm <sup>2</sup>	15mm	Front	2115950011	SPR-G5015	2115950511	SPR-B5015
1x50 mm <sup>2</sup>	27mm	Front	2115950021	SPR-G5027	2115950521	SPR-B5027
1x50 mm <sup>2</sup>	15mm	Side	2115950012	SPS-G5015	2115950512	SPS-B5015
1x50 mm <sup>2</sup>	27mm	Side	2115950022	SPS-G5027	2115950522	SPS-B5027

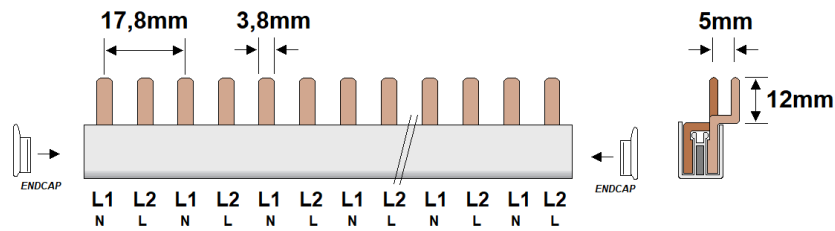

Order code

2 Phase Busbars PIN			Order code	
number of poles		Length	Module width	
6	3x 2p	54 mm	(3MU)	2306020906 16P02006G20
8	4x 2p	72 mm	(4MU)	2306020908 16P02008G20
10	5x 2p	90 mm	(5MU)	2306020910 16P02010G20
12	6x 2p	108 mm	(6MU)	2306020912 16P02012G20
18	9x 2p	162 mm	(9MU)	2306020918 16P02018G20
24	12x 2p	216 mm	(12MU)	2306020924 16P02024G20
36	18x 2p	324 mm	(18MU)	2306020936 16P02036G20
48	24x 2p	432 mm	(24MU)	2306020948 16P02048G20
108	54x 2p	1016 mm	(54MU)	<b>2306162200</b> 16P002G20
Busbar endcap				<b>2306169020</b> SVK2EC

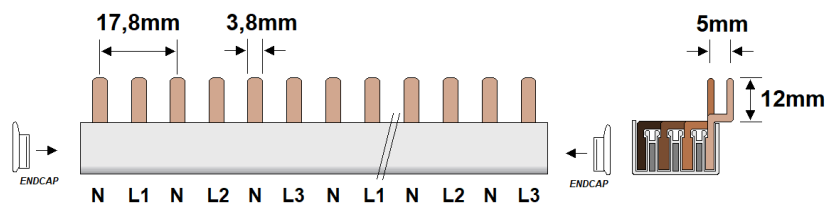

Order code

3+N Phase Busbars PIN			Order code	
number of poles		Length	Module width	
12	6x 2p	108 mm	(6MU)	2306050912 16P04012G20
18	9x 2p	162 mm	(9MU)	2306050918 16P04018G20
24	12x 2p	216 mm	(12MU)	2306050924 16P04024G20
30	15x 2p	270 mm	(15MU)	2306050930 16P04030G20
36	18x 2p	324 mm	(18MU)	2306050936 16P04036G20
42	21x 2p	378 mm	(21MU)	2306050942 16P04042G20
48	24x 2p	432 mm	(24MU)	2306050948 16P04048G20
108	54x 2p	1016 mm	(54MU)	<b>2306162400</b> 16P004G20
Busbar endcap				<b>2306169040</b> SVK4EC

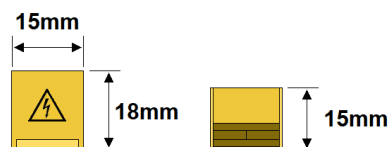

Order code

Busbar protection cover PIN			Order code	
number of poles	Busbar type	Cross section		
2	1x 2p	PIN (2p - 17,8mm)	10-16mm <sup>2</sup>	<b>2115900015</b> IK-D

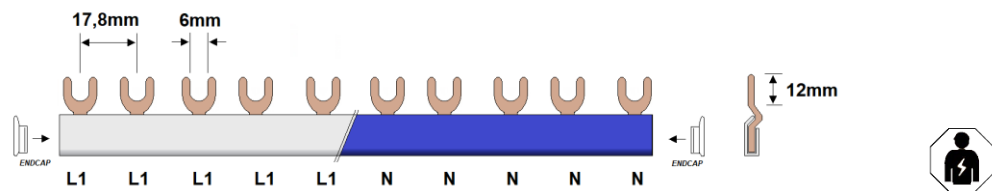

Order code

1 Phase Busbars PIN			Module width	Grey		Blue	
number of poles	Length						
6	6x 1p	107 mm	(6MU)	2306110006	16F01006G06	2306119006	16F01006B06
9	9x 1p	160 mm	(9MU)	2306110009	16F01009G06	2306119009	16F01009B06
12	12x 1p	212 mm	(12MU)	2306110012	16F01012G06	2306119012	16F01012B06
15	15x 1p	267 mm	(15MU)	2306110015	16F01015G06	2306119015	16F01015B06
18	18x 1p	320 mm	(18MU)	2306110018	16F01018G06	2306119018	16F01018B06
21	21x 1p	374 mm	(21MU)	2306110021	16F01021G06	2306119021	16F01021B06
24	24x 1p	427 mm	(24MU)	2306110024	16F01024G06	2306119024	16F01024B06
54	54x 1p	1016 mm	(54MU)	<b>2306161100</b>	16F001G06	<b>2306161101</b>	16F001B06
Busbar endcap				<b>2306169011</b>	SVK1EC1	<b>2306169011</b>	SVK1EC1

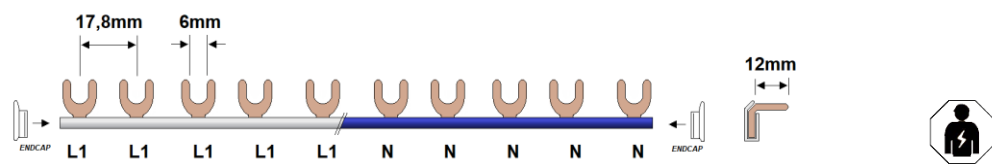

Order code

1 Phase Busbars PIN			Module width	Grey		Blue	
number of poles	Length						
6	6x 1p	107 mm	(6MU)	2306110106	16F01006G96	2306119106	16F01006B96
9	9x 1p	160 mm	(9MU)	2306110109	16F01009G96	2306119109	16F01009B96
12	12x 1p	212 mm	(12MU)	2306110112	16F01012G96	2306119112	16F01012B96
15	15x 1p	267 mm	(15MU)	2306110115	16F01015G96	2306119115	16F01015B96
18	18x 1p	320 mm	(18MU)	2306110118	16F01018G96	2306119118	16F01018B96
21	21x 1p	374 mm	(21MU)	2306110121	16F01021G96	2306119121	16F01021B96
24	24x 1p	427 mm	(24MU)	2306110124	16F01024G96	2306119124	16F01024B96
54	54x 1p	1016 mm	(54MU)	<b>2306161110</b>	16F001G96	<b>2306161111</b>	16F001B96
Busbar endcap				<b>2306169010</b>	SVK1EC	<b>2306169010</b>	SVK1EC

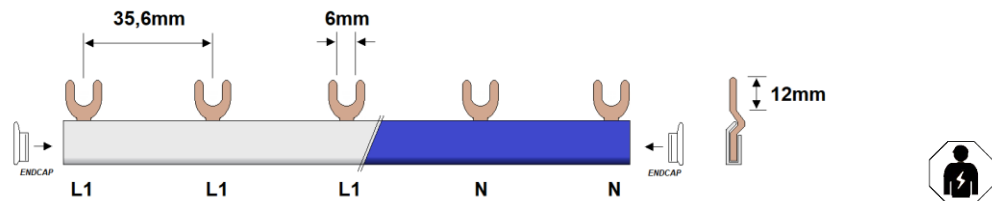

Order code

1 Phase Busbars PIN			Grey		Blue	
number of poles	Length	Module width				
6	2x 1p	212 mm (12MU)	2306110206	16F01106G06	2306119206	16F01106B06
9	3x 1p	320 mm (18MU)	2306110209	16F01109G06	2306119209	16F01109B06
12	4x 1p	427 mm (24MU)	2306110212	16F01112G06	2306119212	16F01112B06
27	5x 1p	1016 mm (54MU)	<b>2306161120</b>	16F011G06	<b>2306161121</b>	16F011B06
Busbar endcap			<b>2306169011</b>	SVK1EC1	<b>2306169011</b>	SVK1EC1

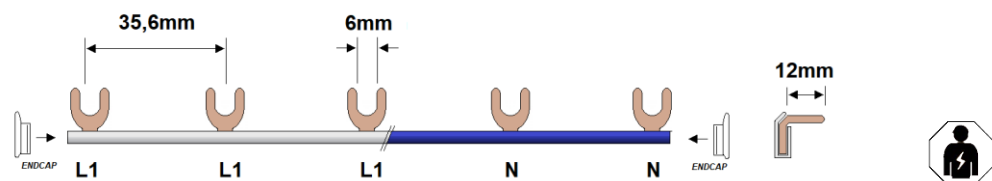

Order code

1 Phase Busbars PIN			Grey		Blue	
number of poles	Length	Module width				
6	2x 1p	212 mm (12MU)	2306110306	16F01106G96	2306119306	16F01106B96
9	3x 1p	320 mm (18MU)	2306110309	16F01109G96	2306119309	16F01109B96
12	4x 1p	427 mm (24MU)	2306110312	16F01112G96	2306119312	16F01112B96
27	5x 1p	1016 mm (54MU)	<b>2306161130</b>	16F011G96	<b>2306161131</b>	16F011B96
Busbar endcap			<b>2306169010</b>	SVK1EC	<b>2306169010</b>	SVK1EC

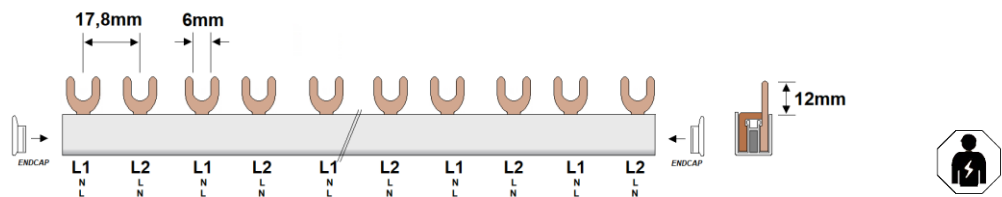

**2 Phase Busbars PIN**

number of poles		Length	Module width	Order code	
6	3x 2p	107 mm	(6MU)	2306020006	16P02006G00
8	4x 2p	142 mm	(8MU)	2306020008	16P02008G00
10	5x 2p	178 mm	(10MU)	2306020010	16P02010G00
12	6x 2p	212 mm	(12MU)	2306020012	16P02012G00
14	7x 2p	249 mm	(14MU)	2306020014	16P02014G00
16	8x 2p	285 mm	(16MU)	2306020016	16P02016G00
18	9x 2p	320 mm	(18MU)	2306020018	16P02018G00
20	10x 2p	356 mm	(20MU)	2306020020	16P02020G00
22	11x 2p	392 mm	(22MU)	2306020022	16P02022G00
24	12x 2p	427 mm	(24MU)	2306020024	16P02024G00
54	27x 2p	1016 mm	(54MU)	<b>2306160200</b>	16P002G00
Busbar endcap				<b>2306169020</b>	SVK2EC

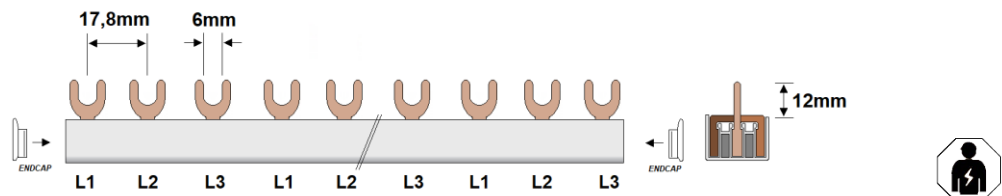

**3 Phase Busbars PIN**

number of poles		Length	Module width	Order code	
6	2x 3p	107 mm	(6MU)	<b>2306030006</b>	16P03006G00
9	3x 3p	160 mm	(9MU)	<b>2306030009</b>	16P03009G00
12	4x 3p	212 mm	(12MU)	<b>2306030012</b>	16P03012G00
15	5x 3p	267 mm	(15MU)	<b>2306030015</b>	16P03015G00
18	6x 3p	320 mm	(18MU)	<b>2306030018</b>	16P03018G00
21	7x 3p	374 mm	(21MU)	<b>2306030021</b>	16P03021G00
24	8x 3p	427 mm	(24MU)	<b>2306030024</b>	16P03024G00
54	18x 3p	1016 mm	(54MU)	<b>2306160300</b>	16P003G00
Busbar endcap				<b>2306169030</b>	SVK3EC



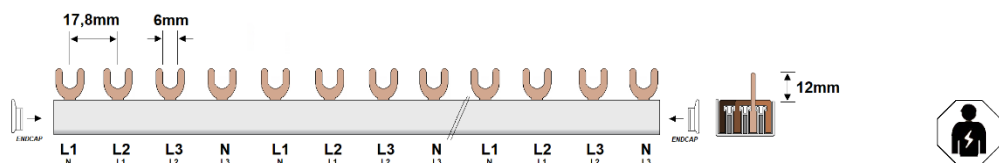

4 Phase Busbars PIN			Order code		
number of poles		Length	Module width		
8	2x 4p	142 mm	(8MU)	<b>2306040008</b>	16P04008G00
12	3x 4p	212 mm	(12MU)	<b>2306040012</b>	16P04012G00
16	4x 4p	285 mm	(16MU)	<b>2306040016</b>	16P04016G00
20	5x 4p	356 mm	(20MU)	<b>2306040020</b>	16P04020G00
24	6x 4p	427 mm	(24MU)	<b>2306040024</b>	16P04024G00
56	14x 4p	1016 mm	(56MU)	<b>2306160400</b>	16P004G00
Busbar endcap				<b>2306169040</b>	SVK4EC

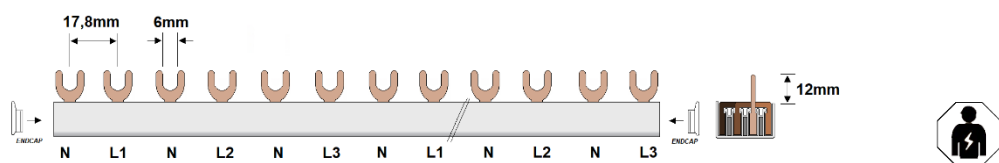

3+N Phase Busbars PIN			Order code		
number of poles		Length	Module width		
12	6x 2p	212 mm	(12MU)	<b>2306050012</b>	16P04012G50
18	9x 2p	320 mm	(18MU)	<b>2306050018</b>	16P04018G50
24	12x 2p	427 mm	(24MU)	<b>2306050024</b>	16P04024G50
56	28x 2p	1016 mm	(56MU)	<b>2306160500</b>	16P004G50
Busbar endcap				<b>2306169040</b>	SVK4EC

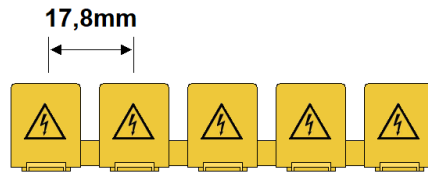

Order code

Busbar protection cover  
breakable

number of poles	Busbar type	Cross section	Order code	
5	5x 1p	PIN and FORK	2115900010	IK



Order code

Direct connection terminal for busbar

Conductor diameter (mm <sup>2</sup> )		Busbar type	Cross section	Order code	
Solid	Stranded				
6-50mm <sup>2</sup>	6-35mm <sup>2</sup>	PIN and FORK	10-16mm <sup>2</sup>	2115910050	BFT50

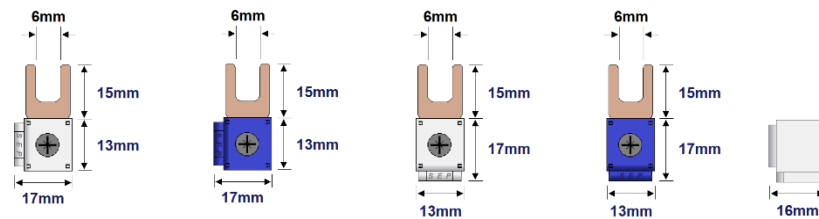

Connection terminals for busbar FORK

Order code

Cross section	Length connection	Connection way	Order code	
			Grey	Blue
1x25 mm <sup>2</sup>	15mm	Front	2115925031 SFR-G2515	2115925531 SFR-B2515
1x25 mm <sup>2</sup>	15mm	Side	2115925032 SFS-G2515	2115925532 SFS-B2515

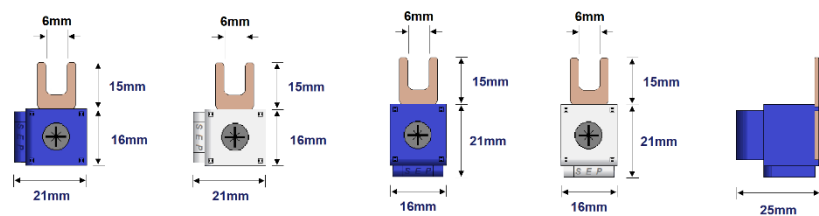

Connection terminals for busbar FORK

Order code

Cross section	Length connection	Connection way	Order code	
			Grey	Blue
1x50mm <sup>2</sup>	15mm	Front	2115950031 SFR-G5015	2115950531 SFR-B5015
1x50 mm <sup>2</sup>	15mm	Side	2115950032 SFS-G5015	2115950532 SFS-B5015



**General**

The SEP Fork type busbar 30mm<sup>2</sup> is a heavy-duty busbar that is specially designed as a feeding busbar for components with high currents. The busbar is plated to prevent corrosion during storage and usage. The use of busbars provides a reliable and efficient connection, reduces failures, and enhances heat management within the cabinet.



**General parameters**

Insulated busbar in combination with endcap  
 The busbar can be cut to the required size as needed

**Technical parameters**

Complies with	IEC 61439-1   2000-08
According	IEC 664
Busbar material	Tin plated E-Cu-ETP
Isolation material	PC
Form test	125°C (after 1,8MPa)
Glow wire test	960°C according IEC60895-2-12
Flammability class	V0
Tracking index	550
Short circuit strength	25kA / 100A gl
Disruptive strength	36kV / mm
Climate stability	IEC 68-2
Operating voltage	500V AC
Surge voltage	4kV
Isolation group	According VDE 0110-T1
Overtoltage category	III
Degree of soiling	2
Colors	Related to RAL7035 (grey)
Type	FORK
Cross section	30mm <sup>2</sup>
Max. current one side line-in	125A
Max. current central line-in	210A*

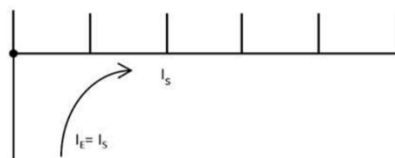

ONE SIDE LINE-IN

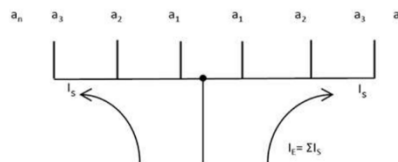

CENTRAL LINE-IN

\* The  $I_s$  is rated on an equal divided demand on both sides of the feeding-main (line-in) of the busbar the sum of the equal divided output current cannot be higher than the busbar current ( $I_s$ )

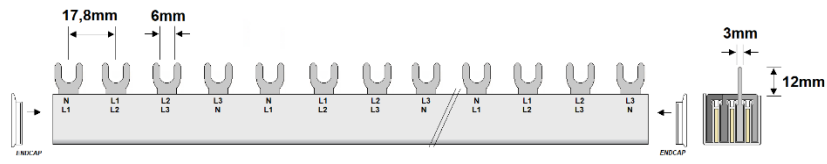

**4 Phase Busbar PIN**

number of poles	Length	Module width
8	2x 4p	8
12	3x 4p	12
16	4x 4p	16
56	14x 4p	56
Busbar end-cover		

**Order code**

<b>2306300408</b>	30F04008G06
<b>2306300412</b>	30F04012G06
<b>2306300416</b>	30F04016G06
<b>2306301400</b>	30F04056G06
<b>2306309040</b>	SVK-30E4



**General**

SEP connection terminals are directly connectable to modular components and available in grey and blue for easy identification. The DTH and DTL versions are 1-pole terminals with 2 connections suitable for up to 10mm<sup>2</sup> wire. Pin position is available in both high and low options.



**General parameters**

- Double connection up to 10mm<sup>2</sup>
- Can be used as a branch or feed-in terminal
- Can be directly connected to Isolator Switch/MCB/RCCB/RCBO

**Technical parameters**

Accordinging	IEC61439
Material base	CU
Isolation material	PC
Nominal voltage	500V
Nominal current	63A
Poles	1
Number of connections (each pole)	2
Type	PIN
Clamp section	10mm <sup>2</sup>
Connection type	Screw each connection
Connection solid wire	0,5 – 10mm <sup>2</sup>
Connection stranded wire	0,5 – 6mm <sup>2</sup>
Tightening torque	1,2 Nm
Pin dimensions	2 - 3,25 - 9,8mm
Width	9mm
Flammability class	V0
Colors	Related to RAL7035 and RAL5015 (grey/blue)

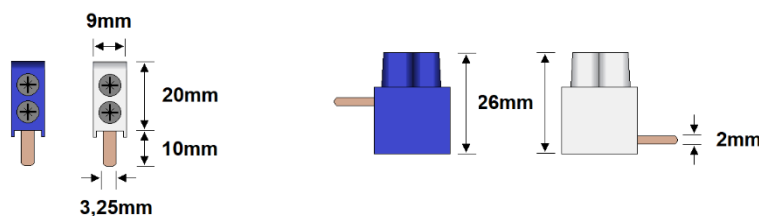

**Order code**

PIN location		Grey	Blue
High	Front	2115900040 DTH	2115900540 DTH-B
Low	Front	2115900041 DTL	2115900541 DTL-B



**General**

SEP connection terminals are designed for direct connection to modular components and are available in grey and blue for easy identification. The DT version is a 1-pole terminal with 2 connections suitable for up to 16mm<sup>2</sup> wire. The terminal is secured with 4 screws (2 per connection) to ensure a secure and reliable connection.



**General parameters**

- Double connection up to 16mm<sup>2</sup>
- Can be used as a branch or feed-in terminal
- Can be directly connected to Isolator Switch/MCB/RCCB/RCBO

**Technical parameters**

According	IEC61439
Material base	CU
Isolation material	PC
Nominal voltage	500V
Nominal current	80A
Poles	1
Number of connections (each pole)	2
Type	PIN
Clamp section	16mm <sup>2</sup>
Connection type	2x Screw each connection
Connection solid wire	1,5 – 16mm <sup>2</sup>
Connection stranded wire	1,5 – 10mm <sup>2</sup>
Tightening torque	1,2 Nm
Pin dimensions	5 - 3,25 - 20mm
Width	17,8mm
Flammability class	V0
Colors	Related to RAL7035 and RAL5015 (grey/blue)

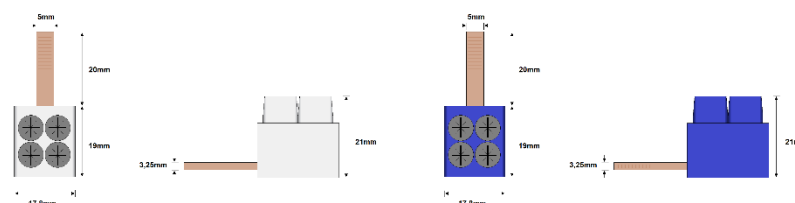

**Order code**

PIN location	Grey		Blue	
	Front	2115900050	DT	2115900550



**General**

SEP connection terminals are designed for direct connection to modular components and available in grey and blue for easy identification. The DT2-25 version is a 1-pole terminal with 2 connections suitable for up to 25mm<sup>2</sup> wire. The terminals can be mutually coupled, allowing them to be mounted as a single unit in the modular component for added convenience.



**General parameters**

Double connection up to 25mm <sup>2</sup>
Can be used as a branch or feed-in terminal
Can be directly connected to Isolator Switch/MCB/RCCB/RCBO
Terminals can be connected together

**Technical parameters**

According	IEC61439
Material base	TIN plated E-CU
Isolation material	PC/ABS
Nominal voltage	690V
Nominal current	100A
Poles	1
Number of connections (each pole)	2
Type	PIN
Clamp section	25mm <sup>2</sup>
Connection type	Screw each connection
Connection solid wire	1,5 – 25mm <sup>2</sup>
Connection stranded wire	1,5 – 16mm <sup>2</sup>
Tightening torque	2 Nm
Pin dimensions	5 - 4 – 12,3mm
Width	17,8mm
Halogen free	Yes
Flammability class	V0
Colors	Related to RAL7035 and RAL5015 (grey/blue)
Connection between terminals	Snap-on

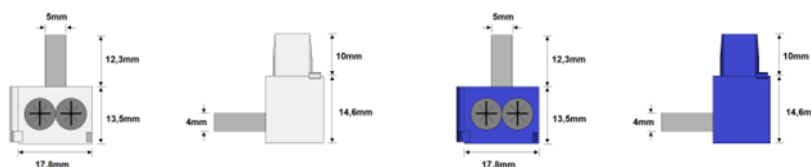

**Order code**

PIN location	Grey	Blue
Front	2115900225 DT2-25	2115905225 DT2-25B



**General**

SEP connection terminals are designed for direct connection to modular components and available in grey and blue for easy identification. The DT3-16 version is a 1-pole terminal with 2 connections suitable for up to 16mm<sup>2</sup> wire. The terminals can be mutually coupled, allowing them to be mounted as a single unit in the modular component for added convenience.



**General parameters**

Triple connection up to 16mm <sup>2</sup>
Can be used as a branch or feed-in terminal
Can be directly connected to Isolator Switch/MCB/RCCB/RCBO
Terminals can be connected together

**Technical parameters**

According	IEC61439
Material base	CU
Isolation material	PC
Nominal voltage	690V
Nominal current	63A
Poles	1
Number of connections (each pole)	3
Type	PIN
Clamp section	16mm <sup>2</sup>
Connection type	2x Screw each connection
Connection solid wire	1,5 – 16mm <sup>2</sup>
Connection stranded wire	1,5 – 10mm <sup>2</sup>
Tightening torque	1,2 Nm
Pin dimensions	5 - 4 – 12,3mm
Width	17,8mm
Flammability class	V0
Colors	Related to RAL7035 and RAL5015 (grey/blue)
Connection between terminals	Snap-on

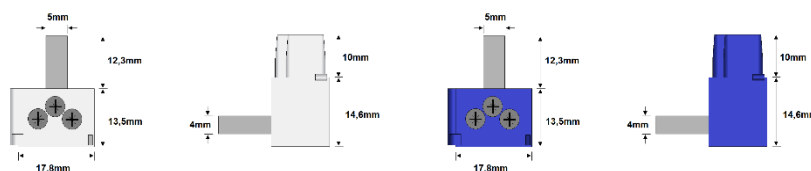

**Order code**

PIN location	Grey		Blue	
	Front	2115900316	DT3-16	2115905316





**General**

SEP connection terminals can be used for direct connection to modular components or in combination with busbars. The terminals are available in gray and blue for easy identification. The SPR-S is a 1-pole terminal suitable for wire up to 25mm<sup>2</sup> or 50mm<sup>2</sup>. The standard version is SPR, while the side-entry version is SPS.



**General parameters**

Suitable as branch or feed-in terminal in combination with busbar  
 Can be directly connected to Isolator Switch/MCB/RCCB/RCBO

**Technical parameters**

	25mm <sup>2</sup>	50mm <sup>2</sup>
According	IEC61439	
Material base	E-CU	
Isolation material	PC	
Nominal voltage	500V AC	
Nominal current	63A	100A
Poles	1	
Number of connections (each pole)	1	
Type	PIN	
Connection way	Frontal or side	
Clamp section	25mm <sup>2</sup>	50mm <sup>2</sup>
Connection type	Screw each connection	
Connection solid wire	1,5 – 25mm <sup>2</sup>	4 - 50mm <sup>2</sup>
Connection stranded wire	1,5 – 16mm <sup>2</sup>	4 – 35mm <sup>2</sup>
Tightening torque	2 Nm	2,5Nm
Pin dimensions	Short	3,8 – 1,8 – 15mm
	Long	3,8 – 1,8 – 27mm
Flammability class	V0	
Colors	Related to RAL7035 and RAL5015 (grey/blue)	

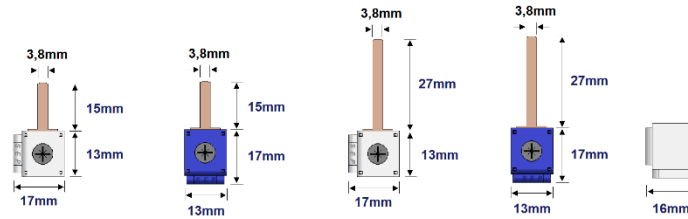

Connection terminals for busbar PIN

Order code

Cross section	Length connection	Connection way	Grey		Blue	
			Order code	Part number	Order code	Part number
1x25 mm <sup>2</sup>	15mm	Front	<b>2115925011</b>	SPR-G2515	<b>2115925511</b>	SPR-B2515
1x25 mm <sup>2</sup>	27mm	Front	<b>2115925021</b>	SPR-G2527	<b>2115925521</b>	SPR-B2527
1x25 mm <sup>2</sup>	15mm	Side	<b>2115925012</b>	SPS-G2515	<b>2115925512</b>	SPS-B2515
1x25 mm <sup>2</sup>	27mm	Side	<b>2115925022</b>	SPS-G2527	<b>2115925522</b>	SPS-B2527

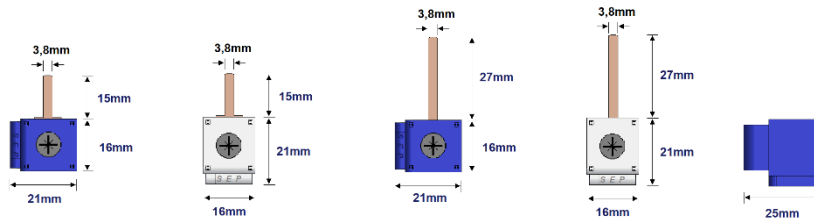

Connection terminals for busbar PIN

Order code

Cross section	Length connection	Connection way	Grey		Blue	
			Order code	Part number	Order code	Part number
1x50mm <sup>2</sup>	15mm	Front	<b>2115950011</b>	SPR-G5015	<b>2115950511</b>	SPR-B5015
1x50 mm <sup>2</sup>	27mm	Front	<b>2115950021</b>	SPR-G5027	<b>2115950521</b>	SPR-B5027
1x50 mm <sup>2</sup>	15mm	Side	<b>2115950012</b>	SPS-G5015	<b>2115950512</b>	SPS-B5015
1x50 mm <sup>2</sup>	27mm	Side	<b>2115950022</b>	SPS-G5027	<b>2115950522</b>	SPS-B5027



**General**

SEP connection terminals can be used for direct connection to modular components or in combination with busbars. The terminals are available in gray and blue for easy identification. The SFR-S is a 1-pole terminal suitable for wire up to 25mm<sup>2</sup> or 50mm<sup>2</sup>. The standard version is SFR, while the side-entry version is SFS.



**General parameters**

Suitable as branch or feed-in terminal in combination with busbar  
 Can be directly connected to Isolator Switch/MCB/RCCB/RCBO

**Technical parameters**

	25mm <sup>2</sup>	50mm <sup>2</sup>
According	IEC61439	
Material base	E-CU	
Isolation material	PC	
Nominal voltage	500V AC	
Nominal current	63A	100A
Poles	1	
Number of connections (each pole)	1	
Type	FORK	
Connection way	Frontal or side	
Clamp section	25mm <sup>2</sup>	50mm <sup>2</sup>
Connection type	Screw each connection	
Connection solid wire	1,5 – 25mm <sup>2</sup>	4 - 50mm <sup>2</sup>
Connection stranded wire	1,5 – 16mm <sup>2</sup>	4 – 35mm <sup>2</sup>
Tightening torque	2 Nm	2,5Nm
Fork dimensions	M6 (1,8 – 15mm)	
Flammability class	V0	
Colors	Related to RAL7035 and RAL5015 (grey/blue)	

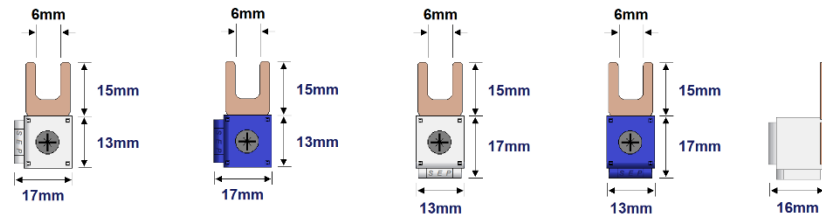

Connection terminals for busbar FORK

Order code

Cross section	Length connection	Connection way	Grey		Blue	
			1x25 mm <sup>2</sup>	15mm	Front	2115925031
1x25 mm <sup>2</sup>	15mm	Side	2115925032	SFS-G2515	2115925532	SFS-B2515

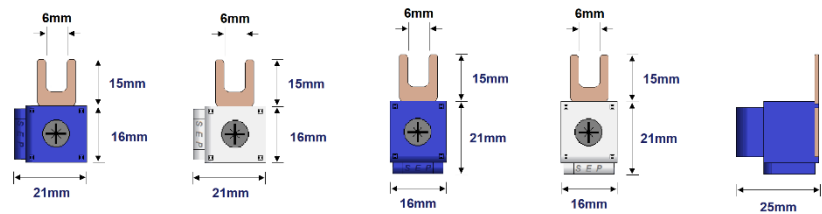

Connection terminals for busbar FORK

Order code

Cross section	Length connection	Connection way	Grey		Blue	
			1x50mm <sup>2</sup>	15mm	Front	2115950031
1x50 mm <sup>2</sup>	15mm	Side	2115950032	SFS-G5015	2115950532	SFS-B5015





## ***Connection Materials***

## **Connection Materials**

**5.03 – 5.39**

AKN	-	Universal terminals	03 - 04
CK	-	Universal connection blocks	05 - 08
CVT/BVT	-	Wiring boxes	09 - 10
LTB	-	Wire-terminals	11 – 12
PDB	-	Power distribution blocks (linkable)	13 – 14
CPDB	-	Power distribution blocks	15 – 16
MDB-16	-	Connective power distribution blocks	17 – 18
KM	-	Standard wires and wire-bridges	19 - 21
LBS	-	Busbar holders	23 - 24
XTB1	-	Terminals	25 - 28
IHT	-	Ferrules	29 – 30
CLUG	-	Cable lugs, butt connector and pin connectors	31 – 34
TA	-	Stretch tulles	35 – 36
7NC	-	Cable glands	37 – 40
CHB-S	-	Vinyl identification stickers	41



**General**

The SEP AKN universal terminal block is a highly versatile solution, equipped with connection covers, screw covers, label options, and can be linked together. It can handle up to 1000VAC and 1500VDC voltages and is suitable for copper and aluminum connections. The AKN terminal block is ideal for a wide range of applications in various industries.



**General parameters**

Compact size
Quick and easy mounting on DIN-rail
Accessoires

**Electrical parameters**

Tested according	CU	EN 60947-7-1
	AL	EN 61238-1
Nominal voltage	Un	1000VAC / 1500VDC
Nominal current	CU	160A
	AL	145A
Isolation voltage	Ui	1000V
Material housing		Polyamide
Flammability class	UL-94	V0
Metal body		Tin-coated aluminum
Screw material		Nickel plated steel
Screws heads		Hexagonal 5mm
Cross section area	CU	2,5 mm <sup>2</sup> – 50 mm <sup>2</sup>
	AL	6 mm <sup>2</sup> – 50 mm <sup>2</sup>
Terminal class		T1
Connector class		A
Tightening torque		4Nm (2.5 mm <sup>2</sup> – 4 mm <sup>2</sup> )
		12Nm (6 mm <sup>2</sup> – 50 mm <sup>2</sup> )
Maximum operating temperature		80°C
Accessories		Markers

**Mechanical parameters**

Device width	17.5mm (21mm)
Device height	63.6mm
Device depth	43.5mm
Mounting	Easy fastening onto 35mm device rail (DIN)
Storage temperature	-20°C + 60°C
Protection degree	IP20
Pollution degree	3
Weight	0,40 kg

\* Installation with flexible conductors (Class 5, according to IEC228) and the specified cross-sections (single conductor installation) is recommended to be done using ferrules.



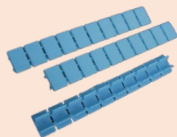

	Order code	
<b>1p - Universal AL/CU terminals</b>		
<b>Color</b>		
Grey	2110205011	AKN-50-11
Blue / grey	2110205012	AKN-50-12
Yellow / green	2110205013	AKN-50-13
Red / grey	2110205014	AKN-50-14
Black / grey	2110205015	AKN-50-15
<b>Marking strips for terminal (cover)</b>		
<b>Alphabetical</b>		
Indication marker strip "L"	2110109200	CK-L
Indication marker strip "L1"	2110109201	CK-L1
Indication marker strip "L2"	2110109202	CK-L2
Indication marker strip "L3"	2110109203	CK-L3
Indication marker strip "N"	2110109204	CK-N
Indication marker strip "PE"	2110109205	CK-PE
Indication marker strip "PEN"	2110109206	CK-PEN
Indication marker strip "R"	2110109210	CK-R
Indication marker strip "S"	2110109211	CK-S
Indication marker strip "T"	2110109212	CK-T
Indication marker strip "U"	2110109213	CK-U
Indication marker strip "V"	2110109214	CK-V
<b>Marking strips for terminal (cover)</b>		
<b>Number</b>		
Indication marker strip "1"	2110109101	CK-N1
Indication marker strip "2"	2110109102	CK-N2
Indication marker strip "3"	2110109103	CK-N3
Indication marker strip "4"	2110109104	CK-N4
Indication marker strip "5"	2110109105	CK-N5
Indication marker strip "6"	2110109106	CK-N6
Indication marker strip "7"	2110109107	CK-N7
Indication marker strip "8"	2110109108	CK-N8
Indication marker strip "9"	2110109109	CK-N9
Indication marker strip "10"	2110109110	CK-N10
<b>Marking strips for terminal (cover)</b>		
<b>Colors</b>		
Indication marker strip WHITE	2110109430	CK-Blanc
Indication marker strip BLUE	2110109410	CK-BL
Indication marker strip RED	2110109420	CK-RD
<b>Marking strips for terminal (cover)</b>		
<b>Symbols</b>		
Indication marker strip EARTH	2110109305	CK-EARTH
Indication marker strip CIRCLED EARTH	2110109306	CK-CEARTH
Indication marker strip PLUS	2110109300	CK-PLUS
Indication marker strip MIN	2110109204	CK-MIN



**General**

The SEP CK universal terminals are highly versatile and can be used in various applications. The terminals have a wide range of cross-section connections, which makes them easy to use. They are made of tin-coated aluminum and have plastic separation, which prevents any corrosion between different materials such as AL and CU conductors. The compact size and fully isolated housing of the terminals make them easy to install next to each other without requiring any partition plates. Alternatively, they can be used as separate terminals in any part of the installation.



**General parameters**

Compact size
Quick and easy mounting on DIN-rail
Accessoires

**Electrical parameters**

Tested according	CU	EN 60947-7-1
	AL	EN 61238-1
Nominal voltage	Un	600V
Nominal current	CU	85 – 425A
	AL	76 – 380A
Isolation voltage	Ui	800V
Material housing		Polyamide
Flammability class	UL-94	V0
Metal body		Tin-coated aluminum
Screw material		Tin-coated steel
Screws heads		Hexagonal
Cross section area	CU	1,5 mm <sup>2</sup> – 240 mm <sup>2</sup>
	AL	2,5 mm <sup>2</sup> – 240 mm <sup>2</sup>
Terminal class		T1

**Mechanical parameters**

Type	Nominal current		Hexagon screw	Conductor size*	Tightening torque
	CU	AL			
CK60	85A	76A	4 mm	1,5 mm <sup>2</sup>	1,5 Nm
				2,5 – 6 mm <sup>2</sup>	3,5 Nm
				10 – 16 mm <sup>2</sup>	7 Nm
CK1-35	135A	120A	4 mm	2,5 - 16 mm <sup>2</sup>	3 Nm
				25 - 35 mm <sup>2</sup>	6 Nm
CK61, CK66, CK71, CK1-50	160A	145A	5 mm	2,5 – 4 mm <sup>2</sup>	4 Nm
				6 - 50 mm <sup>2</sup>	12 Nm
CK62, CK67, CK72	245A	220A	5 mm	16 – 95 mm <sup>2</sup>	20 Nm
CK63, CK68, CK73	320A	290A	8 mm	35 – 95 mm <sup>2</sup>	20 Nm
				120 – 150 mm <sup>2</sup>	30 Nm
CK64, CK69, CK74	425A	380A	8 mm	35 – 70 mm <sup>2</sup>	12 Nm
				95 - 240 mm <sup>2</sup>	45 Nm

\* Installation with flexible conductors (Class 5, according to IEC228) and the specified cross-sections (single conductor installation) is recommended to be done using ferrules.

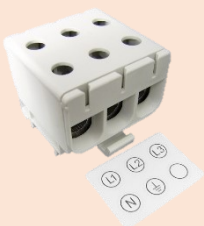

Order code

1.5mm <sup>2</sup> – 16mm <sup>2</sup>	1p (2 connections)		2p (4 connections)		3p (6 connections)	
Color						
Grey	2110100600	CK60				
Blue / grey	2110100602	CK60.2				
Yellow / green	2110100603	CK60.3				
<b>2.5mm<sup>2</sup> – 35mm<sup>2</sup></b>						
Color						
Grey	2110110350	CK1-35	2110120350	CK2-35		
Blue / grey	2110110352	CK1-35.2	2110120352	CK2-35.2		
Yellow / green	2110110353	CK1-35.3	2110120353	CK2-35.3		
<b>2.5mm<sup>2</sup> – 50mm<sup>2</sup></b>						
Color						
Grey	2110100610	CK61	2110100660	CK66	2110100710	CK71
Blue / grey	2110100612	CK61.2	2110100662	CK66.2	2110100712	CK71.2
Yellow / green	2110100613	CK61.3	2110100663	CK66.3	2110100713	CK71.3
<b>16mm<sup>2</sup> – 95mm<sup>2</sup></b>						
Color						
Grey	2110100620	CK62	2110100670	CK67	2110100720	CK72
Blue / grey	2110100622	CK62.2	2110100672	CK67.2	2110100722	CK72.2
Yellow / green	2110100623	CK62.3	2110100673	CK67.3	2110100723	CK72.3
<b>35mm<sup>2</sup> – 150mm<sup>2</sup></b>						
Color						
Grey	2110100630	CK63	2110100680	CK68	2110100730	CK73
Blue / grey	2110100632	CK63.2	2110100682	CK68.2	2110100732	CK73.2
Yellow / green	2110100633	CK63.3	2110100683	CK68.3	2110100733	CK73.3
<b>35mm<sup>2</sup> – 150mm<sup>2</sup></b>						
Color						
Grey	2110100640	CK64	2110100690	CK69	2110100740	CK74
Blue / grey	2110100642	CK64.2	2110100692	CK69.2	2110100742	CK74.2
Yellow / green	2110100643	CK64.3	2110100693	CK69.3	2110100743	CK74.3
<b>Phase distribution block</b>						
CU conductor size						
2.5mm <sup>2</sup> – 50mm <sup>2</sup>					2110100614	CK61.4
<b>Distribution blocks</b>						
CU conductor size						
2.5mm <sup>2</sup> – 35mm <sup>2</sup>					2110110357	CK1-35.7
2.5mm <sup>2</sup> – 50mm <sup>2</sup>					2110110507	CK1-50.7

Order code

**Terminal covers**

CK60 #		-
CK61#, CK66#, CK71#	2110109030	CK-50-C
CK62#, CK67#, CK72#	2110109040	CK-95-C
CK63#, CK68#, CK73#	2110109050	CK-150-C
CK64#, CK69#, CK74#	2110109060	CK-240-C

**Marking strips for terminal (cover)**

Alphabetical

Indication marker strip "L"	2110109200	CK-L
Indication marker strip "L1"	2110109201	CK-L1
Indication marker strip "L2"	2110109202	CK-L2
Indication marker strip "L3"	2110109203	CK-L3
Indication marker strip "N"	2110109204	CK-N
Indication marker strip "PE"	2110109205	CK-PE
Indication marker strip "PEN"	2110109206	CK-PEN
Indication marker strip "R"	2110109210	CK-R
Indication marker strip "S"	2110109211	CK-S
Indication marker strip "T"	2110109212	CK-T
Indication marker strip "U"	2110109213	CK-U
Indication marker strip "V"	2110109214	CK-V

**Marking strips for terminal (cover)**

Number

Indication marker strip "1"	2110109101	CK-N1
Indication marker strip "2"	2110109102	CK-N2
Indication marker strip "3"	2110109103	CK-N3
Indication marker strip "4"	2110109104	CK-N4
Indication marker strip "5"	2110109105	CK-N5
Indication marker strip "6"	2110109106	CK-N6
Indication marker strip "7"	2110109107	CK-N7
Indication marker strip "8"	2110109108	CK-N8
Indication marker strip "9"	2110109109	CK-N9
Indication marker strip "10"	2110109110	CK-N10

**Marking strips for terminal (cover)**

Colors

Indication marker strip WHITE	2110109430	CK-Blanc
Indication marker strip BLUE	2110109410	CK-BL
Indication marker strip RED	2110109420	CK-RD

**Marking strips for terminal (cover)**

Symbols

Indication marker strip EARTH	2110109305	CK-EARTH
Indication marker strip CIRCLED EARTH	2110109306	CK-CEARTH
Indication marker strip PLUS	2110109300	CK-PLUS
Indication marker strip MIN	2110109204	CK-MIN

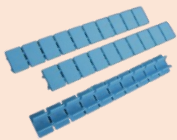

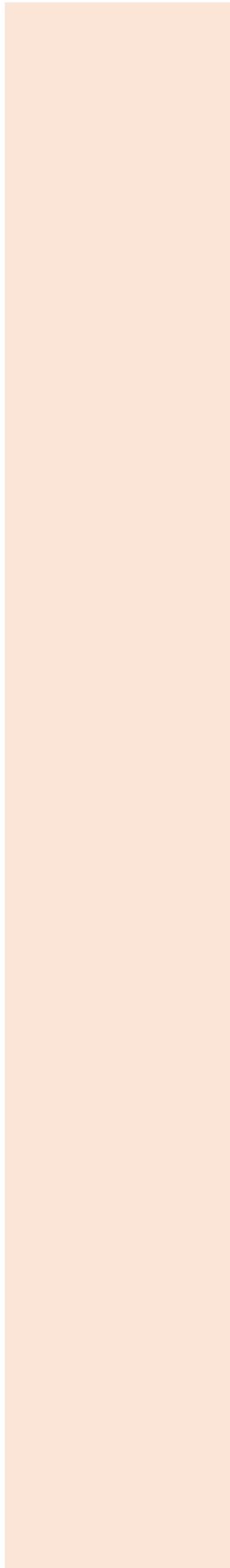

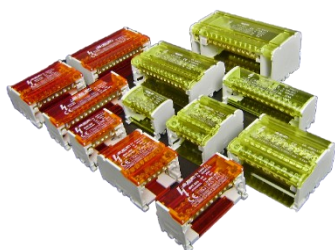

**General**

The BVT/CVT connection wiring boxes from SEP are designed to provide an effective solution for circuit distribution within a distribution-control panel. These boxes come with a transparent cover that allows for easy visual inspection of the connections. The wire connections are carefully selected and positioned to ensure the highest possible filling rate for up to 85% of the panel. This ensures that the wiring is organized and compact, making it easier to manage and troubleshoot.



**General parameters**

Connection boxes suitable for distribution circuits
The transparent cover allows for visual inspection
Insulating screen between each row
High filling rage

**Electrical parameters**

Complies with		IEC 60497-7-1601
Nominal voltage	Un	230/400VAC
Rated frequency		50/60Hz
Rated current	Ie	100A, 125A, 160A
Short time withstand	Icw	4.5kA, 6kA
Rated isolation voltage	Ui	500V
Rated impulse withstand current	Ipk	20kA
Operating temperature		-25°C + 85°C
Contact material		Brass
Isolation material		Thermoplastic
Flammability class		V0
Colors		Red / Yellow

**Mechanical parameters**

Mounting	Easy fastening onto 35mm device rail (DIN)
Degree of protection	IP20
Installation class	II
Terminals	Screw
Storage temperature	-25°C + 85°C
Pollution degree	2

**Mechanical parameters**

Type	Width	Height	Depth	Weight
BVT-207	64mm	50mm	50mm	0,11kg
BVT-211	100mm	50mm	50mm	0,16kg
BVT-215	130mm	50mm	50mm	0,21kg
BVT-407	64mm	90mm	50mm	0,21kg
BVT-411	100mm	90mm	50mm	0,31kg
BVT-415	130mm	90mm	50mm	0,40kg
CVT-207	65mm	45.5mm	51mm	0,11kg
CVT-215	132mm	45.5mm	51mm	0,21kg
CVT-407	65mm	89.5mm	51mm	0,21kg
CVT-411	100mm	89.5mm	51mm	0,31kg
CVT-415	132mm	89.5mm	51mm	0,40kg
CVT-1411	167mm	90.5mm	70mm	0,74kg

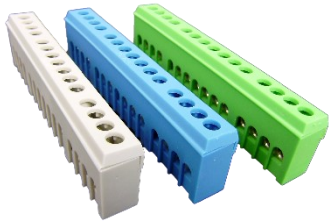

100A / 6kA number of connections	Order code	
	2 Conductive row	4 Conductive row
7	2112110207 BVT-207	2112110407 BVT-407
11	2112110211 BVT-211	2112110411 BVT-411
15	2112110215 BVT-215	2112110415 BVT-415
125A / 4,5kA		
Number of connections	2 Conductive row	4 Conductive row
7	2112120207 CVT-207	2112120407 CVT-407
11	2112120215 CVT-215	2112120411 CVT-411
15		2112120415 CVT-415
160A / 6kA		
Number of connections	2 Conductive row	4 Conductive row
11		2112121411 CVT1411

**General**

The SEP LTB terminal block bar connects multiple wires to one line in a panel. It clicks onto a 35mm device rail for quick installation. Three colors help with oversight of the wiring. This product streamlines complex wiring configurations. It is reliable and efficient for use in control panels. Overall, a valuable solution.

**General parameters**

Connection boxes suitable for distribution circuits  
Fully isolated

**Electrical parameters**

Complies with		IEC 60497-7-1601
Nominal voltage	Un	250/450VAC
Rated frequency		50/60Hz
Rated current	Ie	63A
Rated isolation voltage	Ui	500V
Operating temperature		-25°C + 85°C
Contact material		Brass
Isolation material		Polyamide 66
Flammability class		V2
Colors		Grey / blue / green

**Mechanical parameters**

Mounting	Easy fastening onto 35mm device rail (DIN)		
Degree of protection	IP20		
Installation class	II		
Terminals	Screw		
Poles	7, 12, 15		
Cross section	6 x 9 mm <sup>2</sup>		
Cross section solid wire	2,5 mm <sup>2</sup> - 16 mm <sup>2</sup>		
Cross section stranded wire	2,5 mm <sup>2</sup> - 10 mm <sup>2</sup>		
Storage temperature	-25°C + 100°C		
Pollution degree	3		

**Dimensions**

Type	Width	Height	Depth	Weight
7 connections	35mm	53mm	26,3mm	
12 connections	35mm	88mm	26,3mm	
15 connections	35mm	108mm	26,3mm	



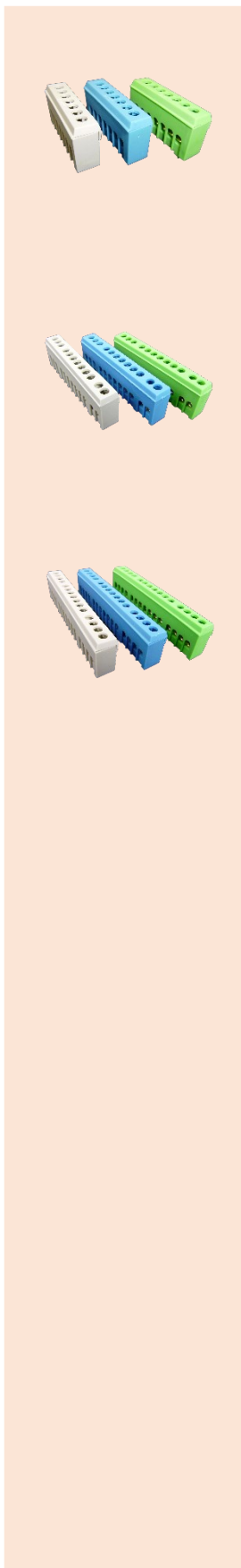

Order code

Type number of connections	Grey		Blue		Green	
	7	2111000070	LTB-G07	2111000072	LTB-BL07	2111000073
12	2111000120	LTB-G12	2111000122	LTB-BL12	2111000123	LTB-GR12
15	2111000150	LTB-G15	2111000152	LTB-BL15	2111000153	LTB-GR15





**General**

SEP PDB power distribution blocks provide an economical and simple solution to establish multiple connections on an electrical board from a single source. They are available in several models to meet varying needs and can be easily mounted on a standard DIN35mm rail or directly onto a mounting plate attached to the enclosure wall.



**General parameters**

The tinned brass block can be used to directly connect copper or aluminum conductors, or with the use of ferrules

Single poles – modular snap-together blocks for building multi-pole

The wire funneling allows for up to 95% filling of the screw connection width

The transparent cover allows for visual inspection of the conductor and confirmation of proper connection

**Electrical parameters**

Complies with		IEC 60497-7-1 / EN 60998-1 BS IEC 60947-7-1 / BS EN 60998-1
Nominal voltage	Un	1000VAC
Rated frequency		50/60Hz
Rated current	Ie	80, 125, 160, 250, 400, 500A
Rated insulated voltage	Ui	690V
Short time withstand	Icw (1s)	3kA, 4,2kA, 11,8kA, 24.5kA
Conditional Short-circuit current	Icc	11,kA, 15kA, 24.3kA,
Short-Circuit Current Rating		100kA
Operating temperature		-55°C + 110°C
Contact material		Tinned Brass
Isolation material		Polyamide
Flammability class	UL94	V0

**Mechanical parameters**

Mounting	Easy fastening on a 35mm device rail (DIN)
Degree of protection	IP20
Installation class	II
Terminals	Screw
Storage temperature	-55°C + 110°C
Pollution degree	2

**Mechanical parameters**

Type	Width	Height	Depth	Weight
PDB-80	31 mm	69 mm	46 mm	0,066 kg
PDB-125	31 mm	71 mm	46 mm	0,137 kg
PDB-160	31 mm	71 mm	46 mm	0,137 kg
PDB-250	49 mm	96 mm	50 mm	0,4 kg
PDB-400	49 mm	96 mm	50 mm	0,4 kg
PDB-500	49 mm	96 mm	50 mm	0,36 kg



PDB – DIN-rail distribution block					Order code	
<i>Inom</i>	<i>Icw</i>	<i>Connections</i>	<i>Rigid</i>	<i>Stranded</i>		
80A	3kA	7	1x 6-16mm <sup>2</sup> 4x 2,5-6mm <sup>2</sup> 2x 2.5-16mm <sup>2</sup>	1x 6-16mm <sup>2</sup> 4x 2,5-6mm <sup>2</sup> 2x 2.5-16mm <sup>2</sup>	<b>2112100010</b>	PDB-80
125A	4.2kA	8	1x 10-35mm <sup>2</sup> 1x 6-16mm <sup>2</sup> 6x 2,5-16mm <sup>2</sup>	1x 10-35mm <sup>2</sup> 1x 6-16mm <sup>2</sup> 6x 2,5-16mm	<b>2112100020</b>	PDB-125
160A	11,8kA	8	1x 10-70mm <sup>2</sup> 1x 6-16mm <sup>2</sup> 6x 2,5-16mm <sup>2</sup>	1x 10-70mm <sup>2</sup> 1x 6-16mm <sup>2</sup> 6x 2,5-16mm <sup>2</sup>	<b>2112100030</b>	PDB-160
250A	24,5kA	12	1x 35-120mm <sup>2</sup> 2x 6-35mm <sup>2</sup> 4x 2,5-10mm <sup>2</sup> 5x 2,5-16mm <sup>2</sup>	1x 25-95mm <sup>2</sup> 2x 6-25mm <sup>2</sup> 4x 2,5-10mm <sup>2</sup> 5x 2,5-16mm	<b>2112100040</b>	PDB-250
400A	24,5kA	12	1x 95-185mm <sup>2</sup> 2x 6-35mm <sup>2</sup> 4x 2,5-10mm <sup>2</sup> 5x 2,5-16mm <sup>2</sup>	1x70-150mm <sup>2</sup> 2x 6-25mm <sup>2</sup> 4x 2,5-16mm <sup>2</sup> 5x 2,5-16mm	<b>2112100050</b>	PDB-400

PDB – DIN-rail distribution block					Order code	
<i>Inom</i>	<i>Icu</i>	<i>Connections</i>	<i>Rigid</i>	<i>Stranded</i>		
500A	24,5kA	11	2x 6-35mm <sup>2</sup> 4x 2,5-10mm <sup>2</sup> 5x 2.5-16mm <sup>2</sup>	2x 4-25mm <sup>2</sup> 4x 2,5-10mm <sup>2</sup> 5x 2,5-16mm <sup>2</sup>		
				4*15.5*0.8 6*15.5*0.8 2*20*1 3*20*1 4*20*1 5*20*1 6*20*1 2*24*1 3*24*1 4*24*1 5*24*1 6*24*1 8*24*1	<b>2112100060</b>	PDB-500
Feeding flat busbar		1				



**General**

The SEP CPDB power distribution blocks are a cost-effective and simple way to create multiple connections on an electrical board from a single source. With several models available to choose from, they can be easily mounted on a standard DIN35mm rail or directly onto a mounting plate attached to the enclosure wall for added convenience.



**General parameters**

Single pole suitable for distribution circuits
Wire funneling till the screw connection
Fingre safe connections
High filling rate

**Electrical parameters**

Complies with		IEC 60497-7-1
Nominal voltage	Un	690VAC
Rated frequency		50/60Hz
Rated current	Ie	125A, 150A, 160A, 192A, 250A, 400A
Short time withstand	Icw	4.5kA, 10kA, 11.8kA, 15kA, 24.5kA
Short-Circuit Current Rating		100kA
Operating temperature		-55°C + 110°C
Contact material		Brass
Isolation material		Polyamide
Flammability class		V0

**Mechanical parameters**

Mounting	Easy fastening onto 35mm device rail (DIN)
Degree of protection	IP20
Installation class	II
Terminals	Screw
Storage temperature	-55°C + 110°C
Pollution degree	2

**Mechanical parameters**

Type	Width	Height	Depth	Weight
CPDB125/4	16mm	81mm	50mm	
CPDB125/9	16mm	81mm	50mm	
CPDB150/4	24mm	81mm	50mm	
CPDB150/6	24mm	81mm	50mm	
CPDB192/6	32mm	81mm	50mm	
CPDB192/8	32mm	81mm	50mm	
CPDB192/12	32mm	81mm	50mm	
CPDB192/82	32mm	81mm	50mm	

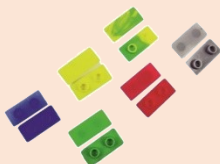

CPDB – DIN-rail / mounting plate distribution block						Order code	
Inom	Icu	Connections	Rigid	Stranded			
125A	4,5kA	5	1x 10-35mm <sup>2</sup> 4x 2,5-10mm <sup>2</sup>	1x 10-35mm <sup>2</sup> 4x 1,5-6mm <sup>2</sup>	<b>2112101254</b>	CPDB125/4	
125A	4,5kA	10	1x 10-35mm <sup>2</sup> 9x 1-4mm <sup>2</sup>	1x 10-35mm <sup>2</sup> 9x 0,5-1mm <sup>2</sup>	<b>2112101259</b>	CPDB125/9	
150A	10kA	5	1x 16-50mm <sup>2</sup> 4x 4-16mm <sup>2</sup>	1x 16-50mm <sup>2</sup> 4x 1,5-6mm <sup>2</sup>	<b>2112101504</b>	CPDB150/4	
150A	10kA	7	1x 16-50mm <sup>2</sup> 6x 2,5-110mm <sup>2</sup>	1x 16-50mm <sup>2</sup> 6x 1,5-6mm <sup>2</sup>	<b>2112101506</b>	CPDB150/6	
192A	15kA	7	1x 25-70mm <sup>2</sup> 6x 4-16mm <sup>2</sup>	1x 25-70mm <sup>2</sup> 6x 1,5-6mm <sup>2</sup>	<b>2112101926</b>	CPDB192/6	
192A	15kA	9	1x 25-70mm <sup>2</sup> 8x 2,5-10mm <sup>2</sup>	1x 25-70mm <sup>2</sup> 8x 1,5-6mm <sup>2</sup>	<b>2112101928</b>	CPDB192/8	
192A	15kA	13	1x 25-70mm <sup>2</sup> 12x 1,5-6mm <sup>2</sup>	1x 25-70mm <sup>2</sup> 12x 1-2,5mm <sup>2</sup>	<b>2112101922</b>	CPDB192/12	
192A	15kA	10	2x 25-70mm <sup>2</sup> 8x 2,5-10mm <sup>2</sup>	2x 25-70mm <sup>2</sup> 8x 1,5-6mm <sup>2</sup>	<b>2112101929</b>	CPDB192/82	

CPDB color label				
Color	Size	Using		
Yellow	L1	CPDB125		<b>2112109901</b> CPDB-L1-Y
Green	L1	CPDB125		<b>2112109902</b> CPDB-L1-G
Red	L1	CPDB125		<b>2112109903</b> CPDB-L1-R
Blue	L1	CPDB125		<b>2112109904</b> CPDB-L1-B
Yellow/Green	L1	CPDB125		<b>2112109905</b> CPDB-L1-YG
Yellow	L2	CPDB150 / CPDB192		<b>2112109911</b> CPDB-L2-Y
Green	L2	CPDB150 / CPDB192		<b>2112109912</b> CPDB-L2-G
Red	L2	CPDB150 / CPDB192		<b>2112109913</b> CPDB-L2-R
Blue	L2	CPDB150 / CPDB192		<b>2112109914</b> CPDB-L2-B
Yellow/Green	L2	CPDB150 / CPDB192		<b>2112109915</b> CPDB-L2-YG



**General**

The SEP MDB-16 power distribution block serves as a convenient direct mounting option for MCCBs or main-switches and is primarily used to distribute circuits within a control panel. Each pole can be wired individually or combined as a full block, with a high filling rate and wide range of wire size possibilities that make it a time-saving solution. Its versatility and ease of use make it an ideal choice for many different applications.



**General parameters**

Direct mounting on MCCB or Switch possible
Stand-alone possibility with additional covers
High current block up to 320A

**Technical parameters**

Tested according		IEC-60947-7-1
Poles		1
Connections		12 x 16mm <sup>2</sup> (each pole)
Rated voltage	Ue	690V AC
Rated current	Ie	320A at 40°C
Rated short current	Icw	8,5kA (1 sec)
Peek current	Ipk	30kA
Impulse withstand	Uimp	8kV
Operation temperature		-25°C + 55°C
Connection cover		Yes
Isolation material		Thermoplastic
Flammability class		V0

**Mechanical parameters**

Width		145 mm
Height		85 mm
Depth		120 mm
Mounting		Easy fastening on a 35mm device rail (DIN)
Direct mounting		Feed in terminal 120mm <sup>2</sup>
Degree of protection		IPxx
Minimum cross section solid		4 mm <sup>2</sup>
Maximum cross section solid		16 mm <sup>2</sup>
Minimum cross section stranded		4 mm <sup>2</sup>
Maximum cross section stranded		16 mm <sup>2</sup>
Torque		4 Nm
Terminals		Screw
Storage temperature		-25°C + 70°C
Overvoltage category		III
Pollution degree		3
Weight		0,946 kg

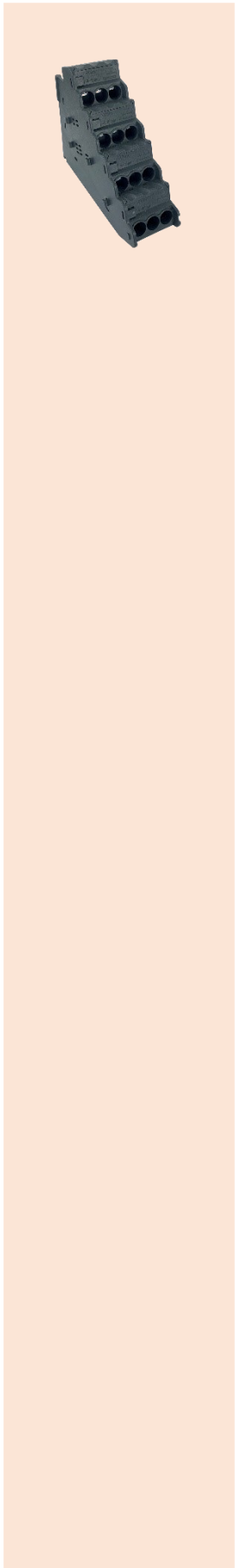

Description	Order code	
Connective distribution block	2112200160	MDB-16
Description		
Connection covers	2112200010	MDB-C





**General**

Installation of our products is made fast and easy thanks to the variety of connection wires available. Our isolation material is highly resistant to temperatures up to 105°C, and the fully enclosed cord-end design provides a secure and reliable solution for your installation needs. Choose our products for a solid and dependable installation.



**General parameters**

Single conductors
High temperature rise for isolation
Wide range of standard wire sizes

**Technical parameters**

Complies with		NEN-EN-IEC 61439 / H07V2-K
Nominal voltage	Un	450/750V
Material		CU
Conductor class		Class 5 (flexibile)
Number of conductors		1
Isolation material		Polyvinylchloride (PVC)
Type terminal		Non-insulated cord-end (fully enclosed)
Maximum temperature of the isolation after mounting without vibration		+5°C + 105°C
Fire retardant		According IEC/EN 60332-1-2
Halogen free		No
Diameter		2,5mm <sup>2</sup> , 4mm <sup>2</sup> , 6mm <sup>2</sup> , 10mm <sup>2</sup> , 16mm <sup>2</sup>
Length		Standard sizes
Isolation color		Blue / Brown / Black / Grey / Green-yellow

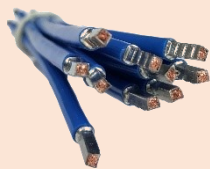

Order code

Blue length mm	2,5mm <sup>2</sup>	4mm <sup>2</sup>	6mm <sup>2</sup>	10mm <sup>2</sup>	16mm <sup>2</sup>
90	2560030901	2560040901	2560060901	2560100901	
125	2560031251	2560041251	2560061251	2560101251	
185	2560031851	2560041851	2560061851	2560101851	
250	2560032501	2560042501	2560062501	2560102501	
265	2560032651	2560042651	2560062651	2560102651	
350	2560033501	2560043501	2560063501	2560103501	2560163501
500	2560035001	2560045001	2560065001	2560105001	2560165001
675	2560036751		2560066751	2560106751	2560166751
800	2560038001		2560068001	2560108001	2560168001
900	2560039001		2560069001	2560109001	2560169001
<b>Brown</b>					
90	2560030902	2560040902	2560060902	2560100902	
125	2560031252	2560041252	2560061252	2560101252	
185	2560031852	2560041852	2560061852	2560101852	
250	2560032502	2560042502	2560062502	2560102502	
265	2560032652	2560042652	2560062652	2560102652	
350	2560033502	2560043502	2560063502	2560103502	2560163502
500	2560035002	2560045002	2560065002	2560105002	2560165002
675	2560036752		2560066752	2560106752	2560166752
800	2560038002		2560068002	2560108002	2560168002
900	2560039002		2560069002	2560109002	2560169002
<b>Black</b>					
90	2560030900	2560040900	2560060900	2560100900	
125	2560031250	2560041250	2560061250	2560101250	
185	2560031850	2560041850	2560061850	2560101850	
250	2560032500	2560042500	2560062500	2560102500	
265	2560032650	2560042650	2560062650	2560102650	
350	2560033500	2560043500	2560063500	2560103500	2560163500
500	2560035000	2560045000	2560065000	2560105000	2560165000
675	2560036750		2560066750	2560106750	2560166750
800	2560038000		2560068000	2560108000	2560168000
900	2560039000		2560069000	2560109000	2560169000
<b>Grey</b>					
90	2560030904	2560040904	2560060904	2560100904	
125	2560031254	2560041254	2560061254	2560101254	
185	2560031854	2560041854	2560061854	2560101854	
250	2560032504	2560042504	2560062504	2560102504	
265	2560032654	2560042654	2560062654	2560102654	
350	2560033504	2560043504	2560063504	2560103504	2560163504
500	2560035004	2560045004	2560065004	2560105004	2560165004
675	2560036754		2560066754	2560106754	2560166754
800	2560038004		2560068004	2560108004	2560168004
900	2560039004		2560069004	2560109004	2560169004
<b>Green/Yellow</b>					
90	2560030903	2560040903	2560060903	2560100903	
125	2560031253	2560041253	2560061253	2560101253	
185	2560031853	2560041853	2560061853	2560101853	
250	2560032503	2560042503	2560062503	2560102503	
265	2560032653	2560042653	2560062653	2560102653	
350	2560033503	2560043503	2560063503	2560103503	2560163503
500	2560035003	2560045003	2560065003	2560105003	2560165003
675	2560036753		2560066753	2560106753	2560166753
800	2560038003		2560068003	2560108003	2560168003
900	2560039003		2560069003	2560109003	2560169003



**General**

Our wiring bridges are designed to connect multiple rows of MCB's and RCCB's in a distribution board. Compatible with both 3-phase and 3-phase with neutral systems on either the left or right side, they streamline the wiring process and make the distribution board more organized and efficient. Trust our wiring bridges to simplify your installation and save you time.



**General parameters**

Multifunctional bridge
Distribution board row distance 125mm and 150mm
MCB/RCCB row connecting

**Technical parameters**

Complies with		NEN-EN-IEC 61439 / H07V2-K
Nominal voltage	Un	450/750V
Nominal current	In	63A
Material		CU
Number of poles		3 or 4 (3+n)
Isolation material		Polyvinylchloride (PVC)
Diameter		10mm <sup>2</sup>
Bridge distance		125mm or 150mm
Type terminal		Non-insulated PIN
Maximum temperature of the isolation after mounting without vibration		+5°C + 90°C
Surge voltage		4kV
Fire retardant		According IEC/EN 60332-1-2
Halogen free		No

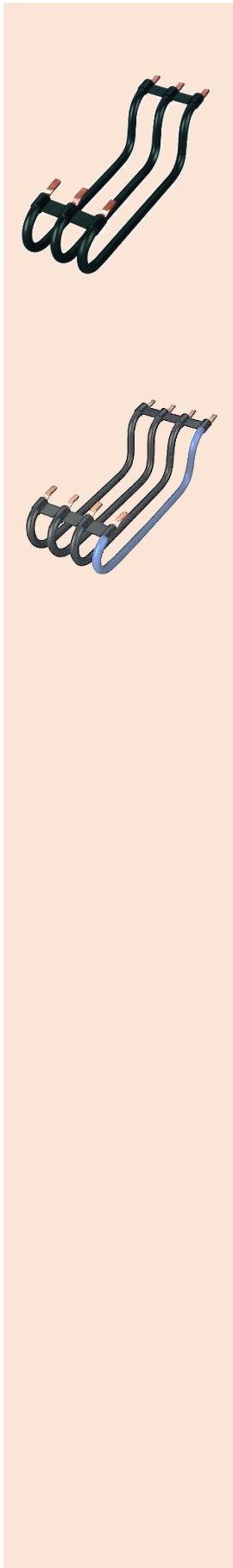

Wire bridge		Order code			
		125mm		150mm	
3		<b>2570031250</b>	KAM-3125	<b>2116010001</b>	KAM-3150
4	Neutral left side	<b>2570041250</b>	KAM-4L125	<b>2570041500</b>	KAM-4L150
4	Neutral right side	<b>2570041251</b>	KAM-4R125	<b>2570041501</b>	KAM-4R150

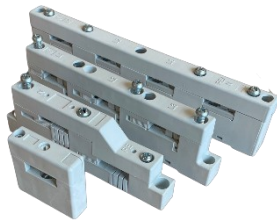

**General**

The SEP LBS bus-bar holder is a versatile product designed to securely hold copper busbars of various sizes. Widely used in low-voltage electricity supply as a distribution rail for both industrial and building applications, it offers a reliable and efficient solution for your electrical needs. Choose our bus-bar holder for a product that can handle a range of sizes and applications with ease.



**General parameters**

Glass fiber-reinforced thermoplastic polyester
A maximum working temperature of 140°C
Flammability class V0

**Technical parameters**

Complies with		VDE 0660 / IEC 439
Max. nominal voltage	Un	1000VAC
Max. nominal current	In	800A
Rated frequency		50/60Hz
Number of poles		1, 2, 3 and 4
Centre distance of poles		60mm
Material		Glass fiber-reinforced thermoplastic polyester
Flammability class	UL94	V0
Short-circuit		Distance between holders according IEC 439

**Mechanical parameters**

		1p	2, 3, 4p
Busbar size		30x10mm	20x5mm – 20x10mm
			25x5mm – 25x10mm
			30x5mm – 30x10mm
Tightening torque	Mounting screw	5-8Nm	3-5Nm
	Cover screw	1-3Nm	1-3Nm

**Dimensions**

Type	Width	Height	Depth	Weight
1p	18mm	60mm	56mm	
2p	20mm	168mm	56mm	
3p	20mm	218.5mm	56mm	
4p	20mm	267mm	56mm	

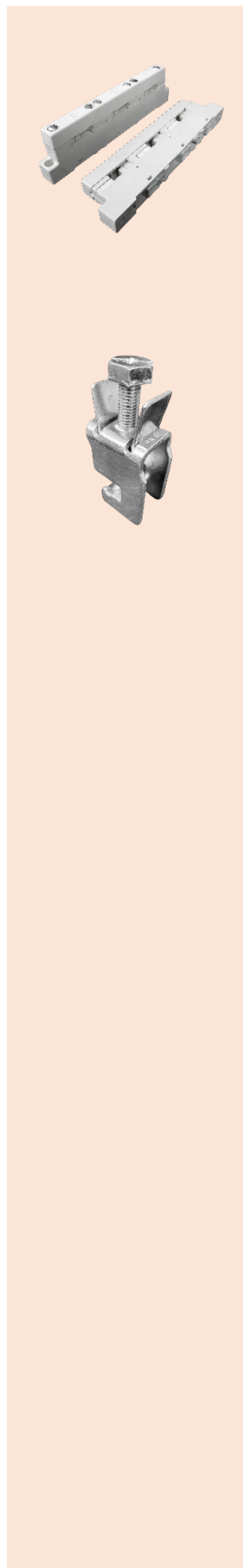

Type			Order code	
Number of poles				
1	(2pcs)		<b>2116010001</b>	LBS-1
2	(2pcs)		<b>2116010002</b>	LBS-2
3	(2pcs)		<b>2116010003</b>	LBS-3
4	(2pcs)		<b>2116010004</b>	LBS-4
<b>Rail clamp – 5mm busbar</b>				
Diameter	Inom (A)	Torque	Width	
1,5 – 16 mm <sup>2</sup>	98A	3Nm		<b>2116000160</b> KK16-5
2,5 – 35 mm <sup>2</sup>	158A	8Nm		<b>2116000350</b> KK35-5
16 – 70 mm <sup>2</sup>	245A	16Nm		<b>2116000700</b> KK70-5
16 – 120 mm <sup>2</sup>	344A	24Nm		<b>2116001200</b> KK120-5
35 – 185 mm <sup>2</sup>	448A	24Nm		<b>2116001850</b> KK185-5
<b>Rail clamp – 10mm busbar</b>				
Diameter	Inom (A)	Torque	Width	
1,5 – 16 mm <sup>2</sup>	98A	3Nm		<b>2116000161</b> KK16-10
2,5 – 35 mm <sup>2</sup>	158A	8Nm		<b>2116000351</b> KK35-10
16 – 70 mm <sup>2</sup>	245A	16Nm		<b>2116000701</b> KK70-10
16 – 120 mm <sup>2</sup>	344A	24Nm		<b>2116001201</b> KK120-10
35 – 185 mm <sup>2</sup>	448A	24Nm		<b>2116001851</b> KK185-10

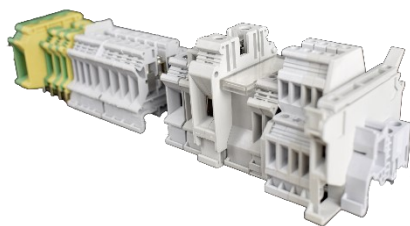

**General**

The SEP XTB1 series terminals are designed with universal mounting feet, making them compatible with various types of rails for added convenience. The enclosed terminal screw hole ensures optimal screwdriver operation and a secure connection. To further enhance their functionality, we offer accessories such as bridges, markers, and end-stoppers to prevent terminals from moving on the rails. Choose our XTB1 series terminals for a versatile and reliable solution.



**General parameters**

Low-profile installation terminal blocks for use in distribution boxes  
 High working temperature of 105°C  
 Flammability class V0

**Technical parameters**

Tested according		IEC 60947-7-1
Rated voltage	Ue	800V (except XTB1-1.5 – 660V)
Number of rows		1
Number of connections each row		2
Connection type		Screw
		U type, G type and 35mm rail
Overvoltage category		III
Operational temperature		-5°C ... 70°C
Operational temperature (max. short time)		-60°C ... 105°C
Material		PA
Flammability class	UL94	V0
Color		Grey
Storage temperature		-25°C ... 60°C
Humidity		30% ... 70%
Installation class		III
Pollution degree		3

**Mechanical parameters**

	Cross sectional	Screw type	Torque
XTB1-1.5N	1,5mm <sup>2</sup>	M2.5	0.22-0.25 Nm
XTB1-2.5N, XTB1-K3, XTB1-5-HESI, XTB1-SLG2.5	2,5mm <sup>2</sup>	M3	0.5-0.7 Nm
XTB1-3N, XTB1-5N, XTB1-K5, XTB1-SLG5	4mm <sup>2</sup>	M3	0.5-0.7 Nm
XTB1-5-TWIN	4mm <sup>2</sup>	M3	0.6-0.8 Nm
XTB1-6N, XTB1-SLG6	6mm <sup>2</sup>	M3	1.5-1.8 Nm
XTB1-10N, XTB1-SLG10	10mm <sup>2</sup>	M3	1.5-1.8 Nm
XTB1-16N, XTB1-SLG16	16mm <sup>2</sup>	M4	1.5-1.8 Nm
XTB1-35N, XTB1-SLG35	35mm <sup>2</sup>	M4	3.2-3.7 Nm

Order code

Connection terminal		Inom (A)	Dimensions (mm)				Size	Order code	XTB1-1.5N
Conductor diameter (mm <sup>2</sup> ) Solid	Stranded		H	W	D				
0.14...1.5	0.14...1	17.5	42.5	4.2	40.5	4	2011000150	XTB1-1.5N	
1...4	1...2.5	32	42.5	6.2	42	6	2011000250	XTB1-2.5N	
0.2...6	0.2...4	32	42.5	5.2	47	5	2011000300	XTB1-3N	
0.25...6	0.25...4	41	42.5	6.2	47	6	2011000500	XTB1-5N	
0.5...10	0.5...6	57	42.5	8.2	47	8	2011000600	XTB1-6N	
0.5...16	1.5...10	76	42.5	10.2	47	10	2011001000	XTB1-10N	
2.5...25	4...16	101	42.5	12.5	54	10	2011001600	XTB1-16N	
0.75...50	0.75...35	125	50.5	15.2	61	10	2011003500	XTB1-35N	

\* Terminal markers should be chosen according to the indicated size

Twin terminal		Inom (A)	Dimensions (mm)				Size	Order code	XTB1-5-TWIN
Conductor diameter (mm <sup>2</sup> ) Solid	Stranded		H	W	D				
0.2...4	0.2...4	32	50.5	6.2	47	6	2013000500	XTB1-5-TWIN	

Double layer terminal		Inom (A)	Dimensions (mm)				Size	Order code	XTB1-K3
Conductor diameter (mm <sup>2</sup> ) Solid	Stranded		H	W	D				
0.2...4	0.2...2.5	25	56.5	5.2	1	5	2012000300	XTB1-K3	
1.5...4	1.5...4	32	56.5	6.2	61	6	2012000500	XTB1-K5	

Fuse terminal		Inom (A)	Dimensions (mm)				Size	Order code	XTB1-5-HESI
Conductor diameter (mm <sup>2</sup> ) Solid	Stranded		H	W	D				
0.2...4	0.2...2.5	6.3	72.5	8.2	56	6	2014000500	XTB1-5-HESI	

Other terminals		Dimensions (mm)			Order code	XTB1-E/UK
Description		H	W	D		
End stopper		43	9	36	2019000010	XTB1-E/UK
Marker plate		43	9.5	5.5	2019000020	XTB1-UBE/D

Order code

Accessoires Terminal type	End-cover	Group separator	Central type connector	Central type separator
XTB1-1.5N	2011100150	2011200010	2019301004	2011400010
XTB1-2.5N	2011100250	2011200010	2019301006	2011400010
XTB1-3N	2011100410	2011200010	2019301005	2011400010
XTB1-5N	2011100410	2011200010	2019301006	2011400010
XTB1-6N	2011100410	2011200010	2019301008	2011400010
XTB1-10N	2011100410	2011200010	2019301010	2011400010
XTB1-16N			2019301012	2011400010
XTB1-K3	2012100350	2012200010	2019301006	2012400010
XTB1-K5	2012100350	2012200010	2019301006	2012400010
XTB1-5-TWIN	2013100500		2019301006	2011400010



Order code

Earth-terminal		Dimensions (mm)				Order code	
Conductor diameter (mm <sup>2</sup> )	Stranded	H	W	D	Size		
1... 4	1...2.5	42.5	6.2	47	6	2015000250	XTB1-SLG2.5
0.2... 6	0.2...4	42.5	5.2	47	5	2015000500	XTB1-SLG5
0.25...6	0.25...6	42.5	8.2	47	8	2015000600	XTB1-SLG6
0.5...16	0.5...10	42.5	10.2	47	10	2015001000	XTB1-SLG10
2.5...25	4...16	42.5	12.2	54	10	2015001600	XTB1-SLG16
0.75...50	0.75...35	50.5	15.2	62	10	2015003500	XTB1-SLG35



Order code

Marking strip for terminal	Size 5	Size 6	Size 8	Size 10
Alphabetical				
Indication marker strip "L1"	2019805001	2019806001	2019808001	2019810001
Indication marker strip "L2"	2019805002	2019806002	2019808002	2019810002
Indication marker strip "L3"	2019805003	2019806003	2019808003	2019810003
Indication marker strip "N"	2019805004	2019806004	2019808004	2019810004
Indication marker strip "PE"	2019805005	2019806005	2019808005	2019810005
Indication marker strip "PEN"		2110109206		
Indication marker strip "R"		2110109210		
Indication marker strip "S"		2110109211		
Indication marker strip "T"		2110109212		
Indication marker strip "U"		2110109213		
Indication marker strip "V"		2110109214		
Indication marker strip "L"		2110109200		



Marker strip for terminal

Numbers	Size 5	Size 6	Size 8	Size 10
Indication marker "1..10"	2019805010	2019806010	2019808010	2019810010
Indication marker "11..20"	2019805020	2019806020	2019808020	2019810020
Indication marker "21..30"	2019805030	2019806030	2019808030	2019810030
Indication marker "31..40"	2019805040	2019806040	2019808040	2019810040
Indication marker "41..50"	2019805050	2019806050	2019808050	2019810050
Indication marker "51..60"	2019805060	2019806060	2019808060	2019810060
Indication marker "61..70"	2019805070	2019806070	2019808070	2019810070
Indication marker "71..80"	2019805080	2019806080	2019808080	2019810080
Indication marker "81..90"	2019805090	2019806090	2019808090	2019810090
Indication marker "91..100"	2019805100	2019806100	2019808100	2019810100

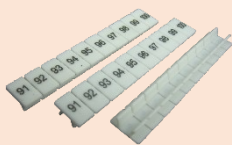

Marking strip for terminal

Colors	Size 5	Size 6	Size 8	Size 10
Indication marker strip WHITE	2019805000	2019806000	2019808000	2019810000
Indication marker strip BLUE	2019805007	2019806007	2019808007	2019810007
Indication marker strip RED	2019805006	2019806006	2019808006	2019810006



Marking strip for terminal

Symbols	Size 5	Size 6	Size 8	Size 10
Indication marker strip EARTH		2110109305		
Indication marker strip CIRCLED EARTH		2110109306		
Indication marker strip PLUS		2110109300		
Indication marker strip MIN		2110109204		

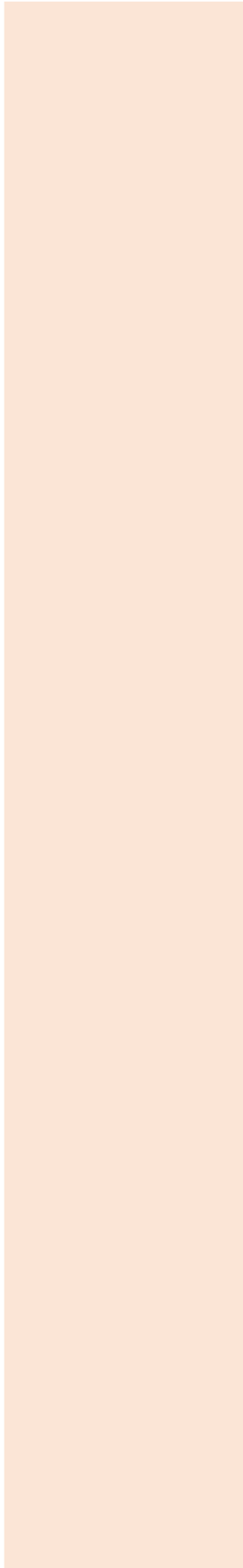



**General**

SEP ferrules are an essential component for protecting the loose wires of a stripped cable in electrical installations or crown strips. Without ferrules, the copper wires are at risk of damage. Our ferrules are available in a range of sizes to suit different applications and ensure a secure connection. Choose our ferrules for added protection and reliability in your electrical installations.



**General parameters**

With and without a protective sleeve  
Wide variety of sizes

**Technical parameters**

Complies with	DIN 46228
Material	E-Cu / Polypropylene
Surface	Tin-plated
Minimum thickness of tin coating	3 µm
Maximum temperature	105°C

					Order code	
<b>Single - Wires and Sleeves (Ferrules)</b>						
Cross section	Color	Length	Total length	Pack		
0,5 mm <sup>2</sup>	White	8 mm	14 mm	100 pcs	2540400050	CIH-0.5
0,75 mm <sup>2</sup>	Grey	8 mm	14 mm	100 pcs	2540400075	CIH-0.75
1 mm <sup>2</sup>	Red	8 mm	14 mm	100 pcs	2540400100	CIH-1
1,5 mm <sup>2</sup>	Black	8 mm	14 mm	100 pcs	2540400150	CIH-1.5
2,5 mm <sup>2</sup>	Blue	8 mm	15 mm	100 pcs	2540400250	CIH-2.5
4 mm <sup>2</sup>	Grey	10 mm	17 mm	100 pcs	2540400400	CIH-4
6 mm <sup>2</sup>	Yellow	12 mm	20 mm	100 pcs	2540400600	CIH-6
10 mm <sup>2</sup>	Red	12 mm	21 mm	100 pcs	2540401000	CIH-10
16 mm <sup>2</sup>	Blue	12 mm	23 mm	100 pcs	2540401600	CIH-16
25 mm <sup>2</sup>	Yellow	16 mm	29 mm	50 pcs	2540402500	CIH-25
35 mm <sup>2</sup>	Red	16 mm	30 mm	50 pcs	2540403500	CIH-35
<b>Twin - Wire and Sleeve (Ferrule)</b>						
Cross section	Color	Length	Total length	Pack		
0,5 mm <sup>2</sup>	White	8 mm	15 mm	100 pcs	2540500050	CIHT-0.5
0,75 mm <sup>2</sup>	Grey	8 mm	15 mm	100 pcs	2540500075	CIHT-0.75
1 mm <sup>2</sup>	Red	8 mm	15 mm	100 pcs	2540500100	CIHT-1
1,5 mm <sup>2</sup>	Black	8 mm	16 mm	100 pcs	2540500150	CIHT-1.5
2,5 mm <sup>2</sup>	Blue	10 mm	18.5 mm	100 pcs	2540500250	CIHT-2.5
4 mm <sup>2</sup>	Grey	12 mm	23 mm	100 pcs	2540500400	CIHT-4
6 mm <sup>2</sup>	Yellow	14 mm	25 mm	100 pcs	2540500600	CIHT-6
10 mm <sup>2</sup>	Red	14 mm	26 mm	100 pcs	2540501000	CIHT-10
16 mm <sup>2</sup>	Blue	16 mm	31 mm	50 pcs	2540501600	CIHT-16

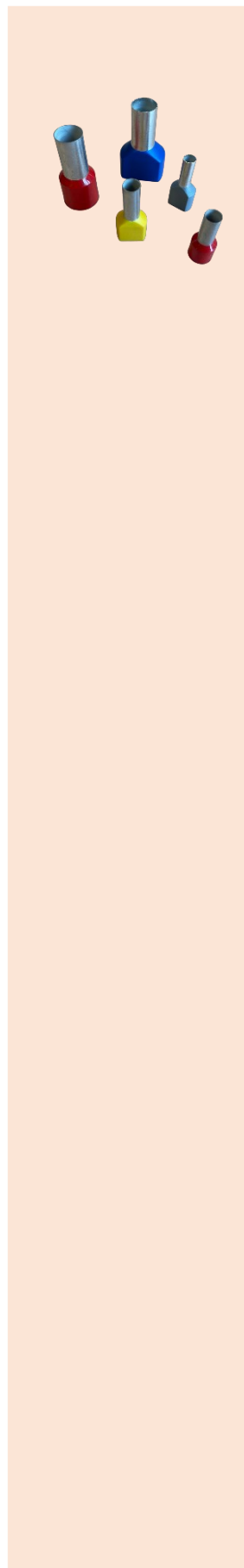

Order code

**Single - Wires and Sleeves (Ferrules)**

Cross section	Color	Length	Total length	Pack	Order code	
0,14 mm <sup>2</sup>	Grey	6 mm	10 mm	500 pcs	2540100014	IH-0.14
0,25 mm <sup>2</sup>	Yellow	6 mm	10 mm	500 pcs	2540100025	IH-0.25
0,34 mm <sup>2</sup>	Turquoise	6 mm	10 mm	500 pcs	2540100034	IH-0.34
0,5 mm <sup>2</sup>	White	8 mm	14 mm	500 pcs	2540100050	IH-0.5
0,75 mm <sup>2</sup>	Grey	8 mm	14 mm	500 pcs	2540100075	IH-0.75
1 mm <sup>2</sup>	Red	8 mm	14 mm	500 pcs	2540100100	IH-1
1,5 mm <sup>2</sup>	Black	8 mm	14 mm	500 pcs	2540100150	IH-1.5
2,5 mm <sup>2</sup>	Blue	8 mm	15 mm	100 pcs	2540100250	IH-2.5
4 mm <sup>2</sup>	Grey	10 mm	17 mm	100 pcs	2540100400	IH-4
6 mm <sup>2</sup>	Yellow	12 mm	20 mm	100 pcs	2540100600	IH-6
10 mm <sup>2</sup>	Red	12 mm	21 mm	100 pcs	2540101000	IH-10
16 mm <sup>2</sup>	Blue	12 mm	23 mm	100 pcs	2540101600	IH-16
25 mm <sup>2</sup>	Yellow	16 mm	29 mm	50 pcs	2540102500	IH-25
35 mm <sup>2</sup>	Red	16 mm	30 mm	50 pcs	2540103500	IH-35
50 mm <sup>2</sup>	Blue	20 mm	36 mm	50 pcs	2540105000	IH-50
70 mm <sup>2</sup>	Yellow	20 mm	37 mm	25 pcs	2540107000	IH-70
95 mm <sup>2</sup>	Red	25 mm	44 mm	25 pcs	2540109500	IH-95
120 mm <sup>2</sup>	Blue	27 mm	48 mm	25 pcs	2540112000	IH-120
150 mm <sup>2</sup>	Yellow	32 mm	58 mm	25 pcs	2540115000	IH-150

**Twin - Wires and Sleeves (Ferrules)**

Cross section	Color	Length	Total length	Pack	Order code	
0,5 mm <sup>2</sup>	White	8 mm	15 mm	500 pcs	2540200050	IHT-0.5
0,75 mm <sup>2</sup>	Grey	8 mm	15 mm	500 pcs	2540200075	IHT-0.75
1 mm <sup>2</sup>	Red	8 mm	15 mm	500 pcs	2540200100	IHT-1
1,5 mm <sup>2</sup>	Black	8 mm	16 mm	500 pcs	2540200150	IHT-1.5
2,5 mm <sup>2</sup>	Blue	10 mm	18.5 mm	250 pcs	2540200250	IHT-2.5
4 mm <sup>2</sup>	Grey	12 mm	23 mm	100 pcs	2540200400	IHT-4
6 mm <sup>2</sup>	Yellow	14 mm	25 mm	100 pcs	2540200600	IHT-6
10 mm <sup>2</sup>	Red	14 mm	26 mm	100 pcs	2540201000	IHT-10
16 mm <sup>2</sup>	Blue	16 mm	31 mm	50 pcs	2540201600	IHT-16

**Uninsulated - Wire Ferrules**

Cross section	Length	Total length	Pack	Order code	
2,5 mm <sup>2</sup>	10 mm	10 mm	1000 pcs	2540002510	OH-2.5
6 mm <sup>2</sup>	10 mm	10 mm	1000 pcs	2540006010	OH-6
10 mm <sup>2</sup>	12 mm	12 mm	500 pcs	2540010012	OH-10
16 mm <sup>2</sup>	12 mm	12 mm	250 pcs	2540016012	OH-16
25 mm <sup>2</sup>	15 mm	15 mm	100 pcs	2540025015	OH-25
35 mm <sup>2</sup>	18 mm	18 mm	100 pcs	2540035018	OH-35
70 mm <sup>2</sup>	25 mm	25 mm	100 pcs	2540070025	OH-70
95 mm <sup>2</sup>	25 mm	25 mm	100 pcs	2540095025	OH-95



**General**

SEP cable lugs, butt connectors, and pin connectors are the perfect solution for constructing control and distribution cabinets. Our lugs are compatible with multistranded round and sector-shaped copper conductors and feature a corrosion-resistant tin plating for added durability. Our products undergo a rigorous production process, including tempering, to ensure maximum strength and reliability. Choose our connectors for a secure and long-lasting connection in your control and distribution cabinets.



**General parameters**

- Cable lugs are tempered during production for easier and more practical usage
- Our cable lugs are heated to 700 degrees to prevent breakage after crimping

**Technical parameters**

Complies with	DIN 46228
Material	Copper (EN 13600 )
Surface	Tin-plated
Conductor material	CU (copper)
Conductor type	Class 2 (DIN EN 60228)
Vibration tested	1B (DIN EN 61373)
Inspection hole	No



Order code

6mm <sup>2</sup> bolt Ø	180° (horizontal)		45°		90°	
	M6	240000606	SE000606			
M8	240000608	SE000608				
<b>10mm<sup>2</sup></b>						
M5	240001005	SE0001005	2400101005	SE4501005	2400201005	SE9001005
M6	240001006	SE0001006	2400101006	SE4501006	2400201006	SE9001006
M8	240001008	SE0001008	2400101008	SE4501008	2400201008	SE9001008
M10	240001010	SE0001010				
<b>16mm<sup>2</sup></b>						
M5	240001605	SE0001605				
M6	240001606	SE0001606	2400101606	SE4501606	2400201606	SE9001606
M8	240001608	SE0001608	2400101608	SE4501608	2400201608	SE9001608
M10	240001610	SE0001610	2400101610	SE4501610	2400201610	SE9001610
M12	240001612	SE0001612				
<b>25mm<sup>2</sup></b>						
M5	240002505	SE0002505				
M6	240002506	SE0002506	2400102506	SE4502506	2400202506	SE9002506
M8	240002508	SE0002508	2400102508	SE4502508	2400202508	SE9002508
M10	240002510	SE0002510	2400102510	SE4502510	2400202510	SE9002510
M12	240002512	SE0002512				
<b>35mm<sup>2</sup></b>						
M6	240003506	SE0003506	2400103506	SE4503506	2400203506	SE9003506
M8	240003508	SE0003508	2400103508	SE4503508	2400203508	SE9003508
M10	240003510	SE0003510	2400103510	SE4503510	2400203510	SE9003510
M12	240003512	SE0003512				
<b>50mm<sup>2</sup></b>						
M6	240005006	SE0005006	2400105006	SE4505006	2400205006	SE9005006
M8	240005008	SE0005008	2400105008	SE4505008	2400205008	SE9005008
M10	240005010	SE0005010	2400105010	SE4505010	2400205010	SE9005010
M12	240005012	SE0005012	2400105012	SE4505012	2400205012	SE9005012
M14	240005014	SE0005014				
<b>70mm<sup>2</sup></b>						
M6	240007006	SE0007006				
M8	240007008	SE0007008	2400107008	SE4507008	2400207008	SE9007008
M10	240007010	SE0007010	2400107010	SE4507010	2400207010	SE9007010
M12	240007012	SE0007012	2400107012	SE4507012	2400207012	SE9007012
M14	240007014	SE0007014				
M16	240007016	SE0007016				
<b>95mm<sup>2</sup></b>						
M8	240009508	SE0009508	2400109508	SE4509508	2400209508	SE9009508
M10	240009510	SE0009510	2400109510	SE4509510	2400209510	SE9009510
M12	240009512	SE0009512	2400109512	SE4509512	2400209512	SE9009512
M14	240009514	SE0009514				
M16	240009516	SE0009516				

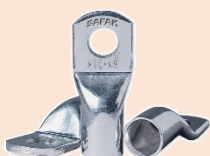

Order code

120mm <sup>2</sup> bolt Ø	Straight		45°	90°
M8	2400012008	SE0012008		
M10	2400012010	SE0012010		
M12	2400012012	SE0012012		
M14	2400012014	SE0012014		
M16	2400012016	SE0012016		
<b>150mm<sup>2</sup></b>				
M8	2400015008	SE0015008		
M10	2400015010	SE0015010		
M12	2400015012	SE0015012		
M14	2400015014	SE0015014		
M16	2400015016	SE0015016		
<b>185mm<sup>2</sup></b>				
M10	2400018510	SE0018510		
M12	2400018512	SE0018512		
M14	2400018514	SE0018514		
M16	2400018516	SE0018516		
<b>240mm<sup>2</sup></b>				
M10	2400024010	SE0024010		
M12	2400024012	SE0024012		
M14	2400024014	SE0024014		
M16	2400024016	SE0024016		
M20	2400024020	SE0024020		



Order code

PIN type		Order code	
Cross-Section	pin length		
10mm <sup>2</sup>	12mm	2400501012	SES001012
16mm <sup>2</sup>	13mm	2400501613	SES001613
25mm <sup>2</sup>	15mm	2400502515	SES002515
35mm <sup>2</sup>	20mm	2400503520	SES003520
50mm <sup>2</sup>	20mm	2400505020	SES005020
70mm <sup>2</sup>	25mm	2400507025	SES007025
95mm <sup>2</sup>	25mm	2400509525	SES009525



Order code

Buttconnector		Order code	
Cross-Section	length		
10mm <sup>2</sup>	30,5mm	2400601000	SEB010030
16mm <sup>2</sup>	35mm	2400601600	SEB016035
25mm <sup>2</sup>	40mm	2400602500	SEB025040
35mm <sup>2</sup>	45mm	2400603500	SEB035045
50mm <sup>2</sup>	50mm	2400605000	SEB050050
70mm <sup>2</sup>	55mm	2400607000	SEB070055
95mm <sup>2</sup>	60mm	2400609500	SEB095060
120mm <sup>2</sup>	54mm	2400601000	SEB120065

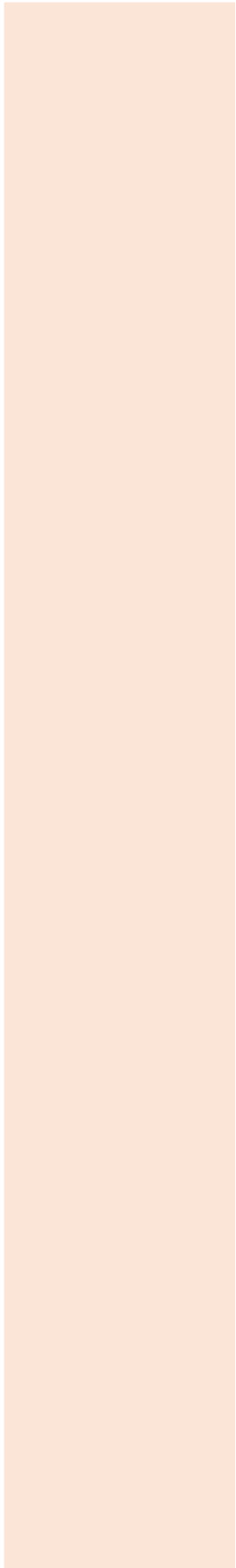



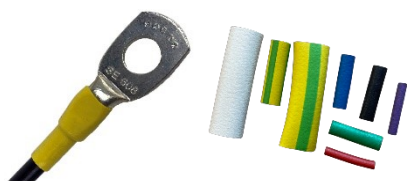

**General**

SEP TA conductor tulle is made of durable neoprene material and can be stretched up to 5 times its diameter. These items are commonly used to provide color marking for conductors and are placed on both ends of the conductor connection with a cable lug. Our stretch tulle offers a reliable and cost-effective solution for conductor marking in your electrical installations. Choose our products for a durable and convenient solution for your conductor marking needs.



**General parameters**

- Cable lugs are tempered during production for easier and more practical usage
- Our cable lugs are heated to 700 degrees to prevent breakage after crimping

**Technical parameters**

Material	Polychloroprene rubber (neoprene)	
Shore A hardness	40 ±5	
Tear resistance	>6,5 MPa	
Max. elongation before break	>500 %	
Tensile strength	>10 kN/m	
Dielectric constant	>13 kV/mm	
Cross resistance	4x10 <sup>9</sup> Ω.cm	
Fire resistance	UL94	V0
Operating temperature continuous	30 tot +90°C	
Operating temperature temporarily peak	110°C	

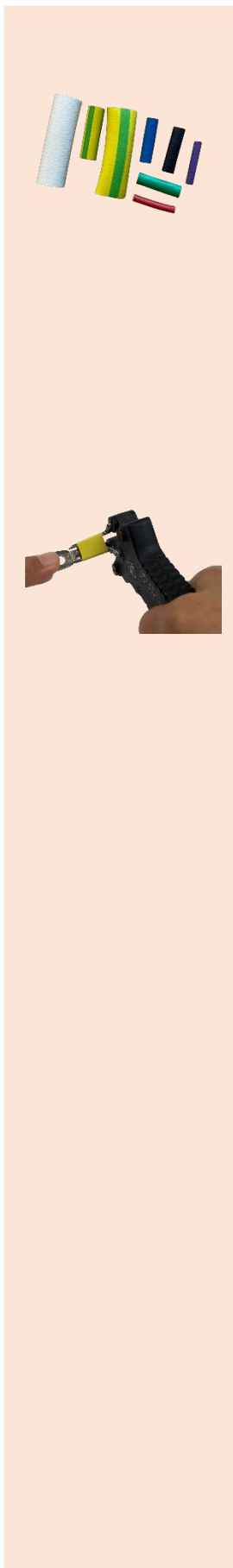

Order code

Color	A1 $\varnothing$ 1,75...3.5mm	A2 $\varnothing$ 3...6mm	A3 $\varnothing$ 5...9mm	A4 $\varnothing$ 7,5...12mm	A5 $\varnothing$ 10...15mm	A8 $\varnothing$ 12...20mm
Black	2490000100	2490000200	2490000300	2490000400	2490000500	2490000800
Blue	2490000101	2490000201	2490000301	2490000401	2490000501	2490000801
Brown	2490000102	2490000202	2490000302			
Yellow/green	2490000103	2490000203	2490000303	2490000403	2490000503	2490000803
Grey	2490000104	2490000204	2490000304			
Red	2490000105	2490000205	2490000305			
Orange	2490000106	2490000206	2490000306			
Yellow	2490000107	2490000207	2490000307			
White	2490000108	2490000208	2490000308			
Green	2490000109	2490000209	2490000309			
Purple	2490000110	2490000210	2490000310			

Order code

size	length of pin	Order code	
A1-A3	3x 30mm	6900000202	TKY2
A2-A5	3x 40mm	6900000203	TKY3
A5-A10	3x 56mm	6900000204	TKY4



**General**

A cable gland feeds cables through a wall while preventing damage and ensuring cabinet protection from external factors. It also provides strain relief for dynamically loaded cables. Choose our cable glands for a secure solution to protect your electrical installations.



**General parameters**

- IP68 with O-ring (5 bar)
- Wide variety of sizes
- PG and Metric sizes
- Antivibration protection

**Technical parameters**

Complies with	PG	DIN 40430
	M	EN 60423
Material Cap nut		Polyamide PA6 – V2
Material Gland body		Polyamide PA6 – V2
Material Sealing ring		TPV
Protection class	IP	IP68
Operational temperature		-20°C ... 100°C
Operational temperature (max. short time)		-30°C ... 150°C
Color		RAL7035

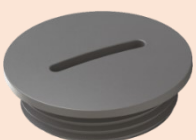
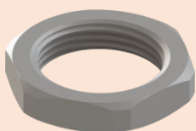

Order code

**Cable glands – Metric thread**

AG Thread	Tightening range	Height	Thread height	Wrench size	Order code	
M 12	3-6,5 mm	24 mm	8 mm	15 mm	2530110010	7NCG-M12
M 16	4-8 mm	28 mm	8 mm	19 mm	2530110011	7NCG-M16
M 16	5-10 mm	29 mm	10 mm	22 mm	2530110012	7NCG-M16L
M 20	6-12 mm	29 mm	10 mm	24 mm	2530110013	7NCG-M20
M 20	10-14 mm	29 mm	10 mm	27 mm	2530110014	7NCG-M20L
M 25	13-18 mm	38 mm	10 mm	33 mm	2530110015	7NCG-M25
M 32	18-25 mm	41 mm	10 mm	42 mm	2530110016	7NCG-M32
M 40	22-32 mm	51 mm	10 mm	53 mm	2530110017	7NCG-M40
M 50	30-38 mm	53 mm	18 mm	60 mm	2530110018	7NCG-M50
M 63	34-44 mm	55 mm	18 mm	70 mm	2530110019	7NCG-M63

**Lock Nuts – Metric thread**

AG Thread	Height	Wrench size	Order code	
M 12 x 1.5	5 mm	18 mm	2530120010	7NCGN-M12
M 16 x 1.5	5 mm	22 mm	2530120011	7NCGN-M16
M 20 x 1.5	6 mm	26 mm	2530120012	7NCGN-M20
M 25 x 1.5	6 mm	32 mm	2530120013	7NCGN-M25
M 32 x 1.5	7 mm	41 mm	2530120014	7NCGN-M32
M 40 x 1.5	7 mm	50 mm	2530120015	7NCGN-M40
M 50 x 1.5	8 mm	60 mm	2530120016	7NCGN-M50
M 63 x 1,5	8 mm	75 mm	2530120017	7NCGN-M63

**Blind stops – Metric thread**

AG Thread	Height	Thread height	Diameter	Order code	
M 12 x 1.5	8,5 mm	6 mm	15 mm	2530130010	7NCGB-M12
M 16 x 1.5	10 mm	7 mm	20 mm	2530130011	7NCGB-M16
M 20 x 1.5	10 mm	7 mm	24 mm	2530130012	7NCGB-M20
M 25 x 1.5	14 mm	10 mm	30 mm	2530130013	7NCGB-M25
M 32 x 1.5	14 mm	10 mm	37 mm	2530130014	7NCGB-M32
M 40 x 1.5	15 mm	10 mm	46 mm	2530130015	7NCGB-M40

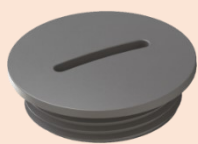
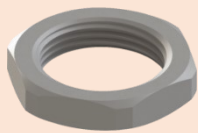

Order code

**Cable glands – PG thread**

AG Thread	Tightening range	Height	Thread height	Wrench size	Order code	
PG 7	3-6.5	24	8	15	<b>2530210010</b>	7NCG-PG7
PG 9	4-8	28	8	19	<b>2530210011</b>	7NCG-PG9
PG 11	5-10	29	8	22	<b>2530210012</b>	7NCG-PG11
PG 13,5	6-12	29	9	24	<b>2530210013</b>	7NCG-PG13.5
PG 16	10-14	33	9	27	<b>2530210014</b>	7NCG-PG16
PG 21	13-18	38	11	33	<b>2530210015</b>	7NCG-PG21
PG 29	18-25	41	11	42	<b>2530210016</b>	7NCG-PG29
PG 36	22-32	51	13	53	<b>2530210017</b>	7NCG-PG36
PG 42	30-38	53	13	60	<b>2530210018</b>	7NCG-PG42
PG 48	34-44	55	14	65	<b>2530210019</b>	7NCG-PG48

**Lock Nuts – PG thread**

AG Thread	Height	Wrench size	Order code	
PG 7	5	19	<b>2530220010</b>	7NCGN-PG7
PG 9	5	19	<b>2530220011</b>	7NCGN-PG9
PG 11	5	24	<b>2530220012</b>	7NCGN-PG11
PG 13,5	6	27	<b>2530220013</b>	7NCGN-PG13.5
PG 16	6	30	<b>2530220014</b>	7NCGN-PG16
PG 21	7	36	<b>2530220015</b>	7NCGN-PG21
PG 29	7	46	<b>2530220016</b>	7NCGN-PG29
PG 36	8	60	<b>2530220017</b>	7NCGN-PG36
PG 42	8	65	<b>2530220018</b>	7NCGN-PG42
PG 48	8	70	<b>2530220019</b>	7NCGN-PG48

**Blind stops – PG thread**

AG Thread	Height	Thread height	Diameter	Order code	
PG 7	8	6	15	<b>2530230010</b>	7NCGB-PG7
PG 9	8.2	6	19	<b>2530230011</b>	7NCGB-PG9
PG 11	8.5	6	22	<b>2530230012</b>	7NCGB-PG11
PG 13,5	8.5	6	25	<b>2530230013</b>	7NCGB-PG13.5
PG 16	8.5	6	27	<b>2530230014</b>	7NCGB-PG16
PG 21	12	8	33	<b>2530230015</b>	7NCGB-PG21
PG 29	11.3	8	44	<b>2530230016</b>	7NCGB-PG29
PG 36	14.3	10	55	<b>2530230017</b>	7NCGB-PG36

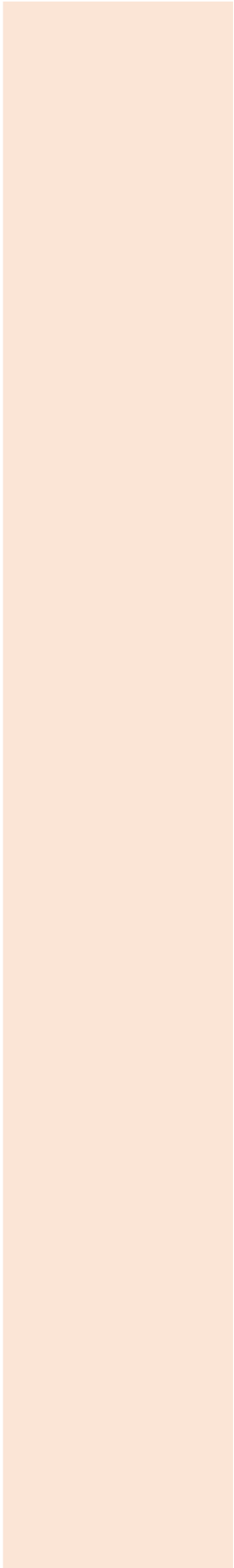

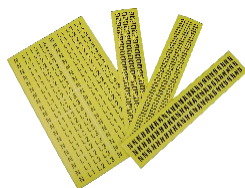

**General**

Identification markers in control or distribution cabinets clarify connection purposes and reduce the risk of wrong wiring. Vinyl stickers provide better clarification on din-modular components or connection bars and are useful for warning operating or service personnel.



**General parameters**

Suitable for challenging surfaces such as PE and PP

**Technical parameters**

Material	Polyvinyl chloride plastic
Resistance	Water-resistance
Durability	8 years
Thickness of sticker	4.33 mil
Laminated	no
Color base	Yellow
Color printing	Black
Service temperature	-40°C... 60°C (121°C short term)
Minimum application temperature	10°C

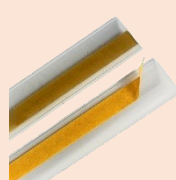
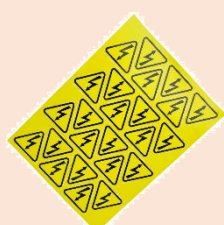

Vinyl sticker				Order code	
Identification	Qty	Width	Height		
L1	78x	9mm	12mm	2119100001	CHB-L1
L2	78x	9mm	12mm	2119100002	CHB-L2
L3	78x	9mm	12mm	2119100003	CHB-L3
N	78x	9mm	12mm	2119100004	CHB-N
PE	78x	9mm	12mm	2119100005	CHB-PE
PEN	78x	9mm	12mm	2119100006	CHB-PEN
N L1 L2 L3	40x	68mm	12mm	2119100010	CHB-NLP
N L1 L2 L3	24x	35mm	10mm	2119100015	CHB-FDPN
'let op kans op restspanning'	100x	35mm	10mm	2119100030	CHB-LETOP
Symbol					
Identification	Qty	Width	Height		
Electrical warning	24x	50mm	55mm	2119100020	CHB-ES
Attributes					
Self adhesive					
Encoder strip		1000mm	20mm	5320900090	GCOM1M
Document holder A4				5320900100	GA4F





**General Terms and Conditions of Sale of:**

**SCHOTMAN ELEKTRO B.V. (Registered with the Chamber of Commerce under number: 01108453), established in Assen**

**Chapter 1: Definitions**

**1.1**

The words below, placed in parenthesis, have the meaning following these terms:

“Customer” every (legal) person to whom Schotman makes an offer and/or with whom Schotman enters into an agreement (a purchase agreement, an agreement for professional services or any other agreement); in these Terms and Conditions the Customer is always designated in the masculine;\*

“Article” an article of these Terms and Conditions;

“Appendices” designs, calculations, drawings, sketches, images, descriptions, manuals, construction and production data, as well as any other document provided by Schotman under the Agreement, or a quotation provided to the Customer because of the Delivery of the Goods or at the time of sending of either the quotation or the Agreement;

“Intellectual Rights” all intellectual and industrial property rights, including but not limited to copyrights, patent rights, model rights, trade name rights and neighboring rights, whether or not these are registered or can be registered;

“Agreement” the agreement made between the Customer and Schotman with regard to the delivery of Goods by Schotman to the Customer;

“Force Majeure” any external circumstances outside Schotman's will that, either permanently or temporarily, hinder or limit the performance of the Agreement, in any case including but not limited to (the direct and indirect consequences of): terrorist attacks, (civil) war, armed conflict, pandemic, internal disturbances, extreme weather phenomena, riot, national, regional or other general strikes, trade embargoes, import or export restrictions, delay at borders, accidents, serious disruptions in Schotman's company or that of its suppliers, and finally, insolvency of any of Schotman's subcontractors;

“Party” Schotman or the Customer;

“Parties” Schotman and the Customer;

“Personal data” data relating to identified or identifiable individuals included in databases, applications, reports, documents and/or any other information in printed or electronic form;

“Schotman” Schotman Elektro B.V. (Registered with the Chamber of Commerce under number: 01108453), with its registered office and principal place of business in (9403 VJ) Assen at Weverstraat 4;

in these Terms and Conditions, Schotman will always be designated in the feminine;\*

*\* Note: In this English version of these Terms and Conditions, both the Customer and Schotman are designated by the personal pronoun 'it'.*

“Terms and Conditions” these General Terms and Conditions of Sale;

“Confidential Information” all information (whether exchanged in written, oral, electronic or any other form, and whether exchanged directly or indirectly) of a confidential nature, such as - and hence not limited to - the financial agreements between Schotman and the Customer;

“Goods” any good Schotman delivers or has delivered to the Customer.

**1.2**

In the context of these Terms and Conditions, “Goods” shall also mean any services provided by Schotman, such as - if applicable to the relationship with the Customer - maintenance, advice and inspection. These Terms and Conditions shall also apply, if possible - to any of Schotman's services that appear from the Agreement. In such case, e.g., “Goods delivered” must be read as “services provided”.

**Chapter 2: Scope**

**2.1**

All offers made by Schotman, all Agreements entered into with it and the performance thereof will solely be governed by these Terms and Conditions.

**2.2**

Schotman shall not accept any reference by the Customer to their own purchase conditions or any other conditions. Therefore, the Customer's purchase conditions or other conditions shall never apply.

**2.3**

In addition to the provisions of Article 2.1, these Terms and Conditions furthermore apply to the contractual relationship between Schotman and the Customer if the Customer has accepted the applicability thereof in earlier agreements with Schotman.

Therefore, by entering into the Agreement with Schotman the Customer accepts the applicability of these Terms and Conditions to all future transactions with Schotman.

**2.4**

If the Agreement is changed or supplemented, these Terms and Conditions also apply to those changes and/or supplements to the Agreement.

**Chapter 3: Establishment of the Agreement**

**3.1**

All offers made remain valid for a period to be indicated by Schotman, except in case of an evident mistake, in which case no Agreement can be made following the acceptance of such an offer.

**3.2**

If no term is stated, the offers made by Schotman will be non-binding and therefore can be revoked by it at any time.

**3.3**

All data in the price lists and brochures provided by Schotman are as accurate as possible. However, these shall only bind Schotman if expressly confirmed by Schotman in writing.

**3.4**

Any price indication, sending of price lists, brochures and/or (other) documentation shall not oblige Schotman to the delivery of Goods. Schotman reserves the right to refuse any orders without stating reasons at any time.

**3.5**

An Agreement is only made with a purchase order for Goods placed by the Customer if Schotman has accepted such purchase order(s) in writing.

**3.6**

No Agreement is made if the Customer makes any reservations or changes with respect to the provisions made by Schotman with the acceptance of a quotation or an order confirmation. Schotman can never be deemed to have agreed with the reservations or changes made by the Customer.

**3.7**

The last Agreement, including the documents mentioned in this Agreement and attached to it, constitutes the entire Agreement between the Parties with regard to the Goods the Agreement relates to, and substitutes any earlier written or oral agreement with regard to those Goods.

**3.8**

A supplement or change to the Agreement (including these Terms and Conditions) is only valid if made in writing and duly signed by the Parties. Such a supplement or change only relates to the delivery of the Goods for which this is expressly agreed and hence, not to any other delivery.

**Chapter 4: Data, drawings, models and manuals**

**4.1**

If Goods are produced by Schotman on the basis of models provided by the Customer, or design data, design drawings or other specifications required by the Customer, the Customer will be responsible for the correctness of these models, data and drawings. Only in case of evident incorrectness that is readily visible, Schotman has a notification obligation. Schotman therefore has no obligation to verify whether the indications given by the Customer are correct for a proper operation or application of the Goods.

**4.2**

All brochures, catalogues, drawings, descriptions, specifications and advertising issued by Schotman were exclusively produced to give an impression of the Goods they describe. These documents do not form part of the Agreement. Moreover, Schotman

may change the specifications, design or material of the Goods, e.g., which are necessary to meet applicable safety standards or the quality level required by Schotman.

#### 4.3

No manufacturing and detailed drawings will be provided by Schotman, unless otherwise agreed in writing.

#### 4.4

The Customer undertakes for itself, its employees and contracted third parties - insofar as applicable - to always consult and comply with the assembly instructions and technical (operating) instructions of the Goods.

### Chapter 5: Delivery time

#### 5.1

If no express delivery date is agreed in writing, the delivery time takes effect on the latter of the following:

a) the date of establishment of the Agreement;

b) the date of receipt of all advance payments to be made by the Customer to Schotman under the Agreement;

c) the date of receipt of the information required by Schotman for the performance of the Agreement.

#### 5.2

The delivery time is always based on the facts and circumstances at the moment the Agreement is entered into, including - therefore not solely - the expected time of delivery of the goods and parts ordered by Schotman for the performance of the Agreement. If - without any negligence on the part of Schotman - a delay occurs with Schotman's suppliers, the delivery time as agreed between Schotman and the Customer will be extended accordingly.

#### 5.3

The delivery time will furthermore be extended by the duration of the delay occurred on the part of Schotman by the fact that the Customer does not meet any obligation under the Agreement or any cooperation required by it with regard to the performance of the Agreement.

#### 5.4

If it is agreed that Schotman takes care of the transport, any delay on the part of the carrier/courier can never be held against Schotman. The delivery time, if applicable, will then be extended by the time of such delay.

#### 5.5

If, subject to the provisions of the previous Articles, the delivery time would nevertheless be exceeded, the Customer has the right to set a reasonable period in writing within which Schotman must ensure the delivery. If after this period Schotman defaults, the Customer has the right to terminate the non-executed part of the Agreement through a written statement. This right of termination can therefore not be relied upon with regard to partial deliveries that have already taken place.

#### 5.6

In the event the agreed date of delivery is exceeded, this will not give the Customer any right not to comply with any remaining obligation under the Agreement or to claim any supplementary or alternative compensation from Schotman.

#### 5.7

Schotman is entitled to deliver the Goods in parts (partial deliveries), which it can invoice separately. The Customer will then have the obligation to pay in accordance with the instalments under the Agreement (including these Terms and Conditions).

### Chapter 6: Retention of title

#### 6.1

Schotman will remain the owner of all Goods (yet to be) delivered by it, as long as the Customer has not paid any claim in respect of the consideration under the Agreement or any other agreement with Schotman.

#### 6.2

The Customer has the obligation to carefully and, as much as possible, identifiable and recognisable as the property of Schotman keep the relevant Goods and on its first request, allow Schotman access to verify this.

#### 6.3

If the Customer does not meet its obligations towards Schotman, or if Schotman, to its discretion, has a well-founded fear that any obligation towards it will not be met, it has the right to collect the Goods it delivered, also after disassembly if necessary, without any prior notice of default. The Customer must cooperate with it and now for then gives Schotman its permission to enter its business premises such that Schotman has the opportunity to collect the Goods it delivered.

#### 6.4

The Customer shall compensate Schotman for the costs in connection with invoking the retention of title, as well as any lower yield, within 5 working days after Schotman has informed the Customer in writing of the amount thus to be fixed.

### Chapter 7: Delivery and transfer of risk

#### 7.1

The Goods will be for the risk (for circumstances such as theft, damage and loss) of the Customer from the time of the delivery, even if the retention of title still applies.

#### 7.2

The Customer has the obligation to immediately purchase the Goods at the moment they are ready for collection, dispatch or transport.

#### 7.3

The delivery will be made from Schotman's business space in Assen, unless otherwise agreed in writing. Transportation costs will be borne by the Customer, who must ensure transportation, unless agreed otherwise in writing. Loading will also be for the account and risk of the Customer.

The delivery will then be considered to take place at the moment the Customer has been informed in writing that the Goods are ready and available to it, or, in the absence of such a notice, at the moment the Goods are handed over to either the Customer or its assistant (carrier).

#### 7.4

If it has been agreed in writing that the delivery is to take place at a different location than from Schotman's business space, Schotman will ensure the transportation or dispatching. In that case, the transportation of goods purchased by the Customer from Schotman will be free of freight charge, as the transportation costs are included in the purchase price of the Goods.

In that case, the delivery will take place by transfer of possession at the location mentioned in the Agreement.

The transportation, dispatching and packaging used for transportation of the Goods the Customer has purchased from Schotman - if Schotman takes care of this - will be done to the best of its knowledge and ability, without Schotman having any liability for it.

#### 7.5

The Customer shall act in such a way and furthermore provide all information and documents required for transportation, dispatch and - if applicable - importation to have the delivery take place as quickly and efficiently as possible. Any additional costs due to not meeting this obligation will be borne by the Customer.

#### 7.6

If the Goods are not purchased by the Customer within the agreed time of delivery, the Goods will be stored by Schotman for the account and risk of the Customer. Schotman shall therefore be entitled to charge the Customer for these additional costs.

### Chapter 8: Control, inspection, testing and claims

#### 8.1

The Customer has the obligation to inspect the Goods delivered or the packaging for numbers and visible defects immediately upon delivery. The Customer shall state (or have stated) any damage (including the packaging) of the Goods or shortage in the number of Goods delivered on the delivery note, invoice and/or carrier documents, and furthermore inform Schotman thereof in writing within 5 working days after the delivery.

#### 8.2

The Customer shall furthermore be held to inspect and test the Goods delivered by Schotman under the given circumstances as soon as possible. Any non-conformity that is then established must be reported to Schotman in writing immediately and in any case within 5 working days after their discovery. If the Customer does not make use of a possibility for inspection or testing in a timely manner, the delivery of Goods will be deemed to be approved.

8.3 For claims with respect to hidden defects a period of three months after the delivery of the Goods applies. After this period no claim can be made for any hidden defect.

Timely claims with regard to hidden defects must be made with Schotman within 5 working days after their discovery.

8.4 If the Customer makes a claim in a timely manner under Article 8.1 or Article 8.2 or 8.3, it shall do this while accurately stating the nature and grounds of the complaints and, if possible, send pictures. On Schotman's first request, the Customer shall give it the opportunity to verify the Customer's statements.

8.5 In the event of breach of the Customer's obligations under Article 8.1 and/or Article 8.2 and/or Article 8.3 and/or Article 8.4, every claim against Schotman on the relevant grounds shall lapse.

8.6 The Customer does not have the right to refuse the Goods because of minor defects.

8.7 The Customer shall allow Schotman to meet any shortcoming appearing from the inspection and/or testing, before the delivery of goods and/or the execution of work can be considered rejected.

8.8 The tints, nuances and/or aesthetic aspect of the Goods will never be a reason to refuse the delivery, or be considered as a non-conformity.

8.9 Claims will only be handled by Schotman if the Customer has met all of its obligations towards Schotman.

#### Chapter 9: Warranty

9.1 Schotman warrants to the Customer that the Goods are free from any design, material and manufacturing faults with normal use for a maximum period of 12 (twelve) months from the invoice date of those Goods. After this period the warranty lapses and Schotman can never be held liable with respect to any non-conformity or other shortcoming.

9.2 The warranty mentioned in the previous Article does not apply to Goods or parts thereof, which:

a) were repaired or adapted by the Customer or third parties without Schotman's permission, such that this - to Schotman's sole discretion - impacted the sustainability of the Goods;

b) are the result of adaptations, accidents, incorrect use, misuse or neglect, or were subjected to abnormal wear and tear;

c) are installed, used or maintained in a way that is in violation of Schotman's or the manufacturer's instructions, or in which Schotman's or the manufacturer's

instructions for assembly, use and maintenance were not followed;

d) were physically or electrically stressed in an abnormal or unusual way, exposed to abnormal or unusual environmental factors, misused or treated or operated in a negligent way;

e) the Customer has not met the provisions of Article 8.

There will also be no warranty for:

f) materials, goods, methods and constructions that were customized following express instructions from the Customer;

g) materials and goods that were incorporated in the Goods by or on behalf of the Customer.

h) Goods and/or the replacement of parts of Goods subject to normal wear and tear.

For all these cases there will be no warranty and Schotman can never be held liable on any grounds whatsoever.

9.3 The warranty under Article 9.1 does also not apply if the Customer does not meet - or not in a timely manner - any of its obligations under the Agreement entered into with Schotman, or under any associated agreement.

9.4 If a legally valid appeal is made on Article 9.1, Schotman will repair all relevant defects in the Goods that are the result of an improper design or material that significantly affects the relevant Goods.

Schotman always has the right not to repair any defected Goods but to replace these by the same or similar Goods that do not show any defect and meet the specifications of its Agreement entered into with the Customer. If Schotman replaces (parts of) Goods to meet its warranty obligations, the replacement Goods will again become or (because of the retention of title) remain its full property.

The Customer shall allow Schotman to carry out the provisions under this Article upon Schotman's first request.

Schotman will obviously not charge any costs for the replacement or repair of the Goods if the warranty provision of Article 9.1 applies.

9.5 In derogation from Article 9.4, Schotman has the right to transfer to the Customer the warranty obligations towards Schotman with regard to Goods or parts of Goods it purchases from third parties. Schotman will be discharged towards the Customer with regard to any non-conformity once it transfers its claim against such third party to the Customer under a deed of transfer, with which the Customer shall agree.

9.6 In addition to the warranty under Article 9.1, Schotman will issue no other warranties with respect to the Goods and - subject to gross negligence or intention of Schotman's management - it can never be held liable on any grounds with regard to the Goods it delivered.

9.7 Schotman does not guarantee that its software will be compatible with all hardware or software products supplied by third parties, that the functioning of the software will be uninterrupted or free of any error, or that all software defects will be corrected.

9.8 Moreover, any legal claim on the basis of this Article on non-conformity must be filed with the competent court within one year after the timely claim, on pain of lapse of rights.

9.9 The burden of proof for having met the conditions as referred to in Article 9.1 and not having met the exceptions as referred to in Article 9.2 will be with the Customer.

9.10 The alleged non-compliance by Schotman of its warranty obligations does not release the Customer from the obligations resulting for it under any agreement entered into with Schotman.

#### Chapter 10: Liability

10.1 Apart from gross negligence or intention of Schotman's management, Schotman will never be liable for any indirect damage, including but not limited to any damage not directly resulting from a damaging event, as well as any special damage of whatever nature, including, *inter alia*, loss of profit, loss of income, interruption in the operation, replacement costs, rise of costs and/or loss of anticipated saving, overhead costs, business damage, and/or loss of electrical connection, damage from usage and/or capital costs;

10.2 Schotman will also never be liable for:

1. damage resulting from work done by the Customer or by third parties in its order;

2. deterioration or loss of any software, firmware, information or loss of memory of the Customer or its customers, incorporated, stored or integrated in equipment returned to Schotman for repair, whether or not these repairs are covered by the warranty;

3. any discharge in the atmosphere, high voltages, chemical impact and loss and damage during throughput.

10.3 The total liability of Schotman for direct damage, except for gross negligence or intention of Schotman's management, in addition to the provisions of the Terms and Conditions will in any case be limited to the maximum amount of the invoice value of the delivered Goods the liability relates to.

10.4 Any condition meant to limit, exclude or establish liability that can be invoked against to Schotman in connection with the goods delivered by suppliers or subcontractors, can also be invoked by Schotman against its Customer.

10.5

Scotman's employees or assistants engaged by Scotman for the performance of the Agreement can claim all defenses from the Customer that can be derived from the Agreement as if it was a party with the Agreement.

10.6

The Customer will indemnify Scotman, its employees and its assistants engaged for the performance of the Agreement against any claim from third parties in connection with Scotman's performance of the Agreement.

10.7

If and insofar Scotman is considered a manufacturer under Book 6 Section 185 et seq. of the Dutch Civil Code, any liability that is not covered by Book 6 Section 185 et seq. of the Dutch Civil Code is excluded.

10.8

In derogation from the provisions of these Terms and Conditions, Scotman will be liable, if and insofar there is a claim for compensation of the relevant damage under the (business) liability insurance taken out by Scotman. This clause does not oblige Scotman to take out and maintain such an insurance, or to take out an insurance with such policy conditions that there could have been coverage.

#### **Chapter 11: Total order amount**

11.1

The prices of the Goods are as stated by Scotman in the accepted quotation or order confirmation, and in the absence thereof the prices included for the Goods in the price list published by Scotman, and in the absence thereof the current prices for the relevant Goods at the time of delivery with Scotman.

11.2

Scotman's prices always are:

\* given in Euros;

\* exclusive of turnover tax or other applicable tax to be paid by the Customer in addition to the payment due for the Goods, unless stated otherwise.

11.3

If any packaging is used this is not included in the price and can be charged to the Customer if Scotman wishes to do so. As soon as the packaging is received back carriage paid and in undamaged condition within two months after delivery, the packaging costs will be credited and Scotman will transfer the amount received for it to the Customer.

11.4

If, to the opinion of Scotman, price determining factors, such as prices of raw materials and/or necessary materials, freight costs, energy costs, insurance premiums, wages, social charges, taxes, import duties, excises, exchange rates are substantially changed two months after the creation of the Agreement, Scotman will have the right to increase the price(s) agreed accordingly. This also applies if, in Customer's point of view, these increases could have been foreseen at the time the agreement was entered into

11.5

Scotman will inform the Customer in writing or by e-mail of the price increase on the basis of the previous Article, and the Customer will then have the right to terminate the agreement entered into with Scotman during a period of 5 working days after this written notice from Scotman.

#### **Chapter 12: Payment and invoicing**

12.1

All payments must be made without any deduction, suspension or settlement, in Euros by deposit or transfer in Scotman's bank account. If no payment term is given by Scotman, the payment must have been received in Scotman's bank account within 30 days after the invoice date. The value date stated on Scotman's bank statements is decisive and therefore regarded as the date of payment.

12.2

If the Customer does not pay any amount owed by it in a timely manner, it will automatically be in default without any prior notice of default.

12.3

If the Customer is in default with any payment, any other claim Scotman may have (if not payable yet) will also immediately be payable by the Customer and with regard to such claim, the default will automatically come into effect without any prior notice of default.

12.4

If the Customer is declared bankrupt, has applied for (provisional) suspension of payments, enters into liquidation, is terminated or has died, or if its assets and claims are attached before or after judgment, all claims Scotman holds against the Customer always are immediately payable without a prior notice of default being required, with interest and costs owed by the Customer.

12.5

From the day on which the Customer is in default it will automatically and without prior notice of default owe to Scotman a default interest equal to the statutory commercial interest under Book 6 Section 119a of the Dutch Civil Code.

12.6

Scotman will at any time have the right, before proceeding to or continuing the delivery or start or continue the performance of an agreement, to demand from the Customer adequate surety for the fulfilment of its payment obligations - such to Scotman's sole discretion - if Scotman believes there is reason to demand surety because of circumstances such as the Customer's solvency or liquidity position, even if there is no connection between these circumstances and the performance of the Agreement.

12.7

If the Customer is unable or refuses to provide the surety required under the previous Article, this will authorize Scotman to terminate the Agreement or suspend its obligations, irrespective of its right of compensation of the costs incurred, loss of profit and any (to be) suffered by it.

12.8

Every payment of the Customer will first be used to pay any interest and costs owed by it and then be deducted from the oldest outstanding receivable.

12.9

As soon as a claim that is due is not paid, Scotman has the right to take collection measures and to engage third parties for this. All resulting judicial and extrajudicial costs will fully be borne by the Customer.

The extrajudicial costs that are then payable by the Customer are fixed at the amount of fifteen per cent (15%) of the entire outstanding amount payable, with a minimum of EUR 300.

#### **Chapter 13 Suspension and termination of the Agreement**

13.1

From the moment any amount owed to Scotman - on whatever grounds - has become payable and has not yet been paid, Scotman shall have the right, without prejudice to its right of compensation and interest, to declare the Agreement terminated in whole or in part by registered letter, without a prior notice of default or judicial intervention being required, and without Scotman being held to any compensation or guarantee and without prejudice to its further rights.

13.2

The retention of title will always be maintained in case of termination of the Agreement, such that Scotman has the right to repossess or have repossessed the relevant Goods in accordance with the provisions of Chapter 6 (Retention of title) of these Terms and Conditions.

13.3

In the event of termination under Article 13.1, the Customer will in any case owe to Scotman: the price agreed for all Goods less the instalments already paid and costs saved by Scotman because of the termination. The Customer shall furthermore owe compensation, including the losses Scotman suffers because of the termination. The Customer shall pay the amount thus determined within 5 working days after Scotman informed the Customer thereof.

13.4

If the provisions of Article 13.1 apply, Scotman also has the authority - to its discretion - before proceeding to termination and without a prior notice of default or judicial intervention being required, to suspend the performance of the Agreement or other agreements it has entered into with the Customer for a maximum of 6 months, such without Scotman being held to any compensation or guarantee, and without prejudice to its further rights. During the period of the suspension Scotman will be authorized and by the end of it will be held to either choose for the performance or termination of the suspended agreement(s) in whole or in part.

13.5

In the event of suspension under Article 13.4, the agreed price will immediately be payable, less the instalments already paid and costs saved by Schotman because of the suspension. Schotman will furthermore be authorized to have the raw materials, materials, parts and other goods reserved, processed and manufactured by it for the performance of the Agreement stored for the account and risk of the Customer.

13.6

The Customer will only and no earlier have the right to end and/or terminate the Agreement if the failure on the part of Schotman has irrevocably been determined in court.

#### Chapter 14 Force Majeure

14.1

If Schotman cannot perform in a timely manner because of Force Majeure, the instalments agreed with it will be extended by the delay period resulting from the situation of Force Majeure. This also applies if the Customer and Schotman have agreed express instalments in the Agreement.

14.2

If the situation of Force Majeure leads to a delay longer than three full calendar months, each of the parties can terminate the Agreement through a registered letter without any further liability or obligation to pay compensation.

14.3

If the Agreement that is terminated under the previous Article was in part executed by Schotman, the agreed price shall be paid by the Customer to Schotman in proportion to the executed part of the agreement within the period that would have applied if the agreement would have been executed in full.

#### Chapter 15 Intellectual Rights

15.1

The Intellectual Rights relating to the Goods will never be transferred and will remain the full property of Schotman or the third party beneficiaries. This also applies to parts of the Goods and the programs the Goods are equipped with.

15.2

The provisions of the previous Article also apply to quotations made by Schotman, as well as their Appendices.

15.3

The Customer will not perform any act, and not allow third parties to perform any act, which could prejudice the Intellectual Rights or the associated goodwill. Therefore, the Customer shall not (in whole or in part) adapt, remove, conceal or process the Goods, or apply other brands on the Goods.

15.4

All promotional and sales documentation Schotman provided to the Customer will remain the property of Schotman, and the Customer shall not allow anyone else to use these.

15.5

The Customer is obliged to immediately notify Schotman in writing of any breach of the Intellectual Rights the Customer has established. If the Customer should objectively have established a breach but states that it did not, the Customer will, however, be considered to have violated the obligation under this Article.

15.6

If a third party alleges that the Goods delivered by Schotman constitute a violation of the Intellectual Rights of this third party, the Customer is held to immediately inform Schotman thereof in writing, such that Schotman can discuss the matter with this third party and defend itself.

#### Chapter 16 Confidentiality and data protection

16.1

The Parties are held to keep confidential any Confidential Information and shall not disclose such information to third parties without the other Party's consent. This does not apply to a transfer to group companies, provided that these are also held to this Article.

16.2

If a Party gets access to Personal Data it shall comply with the relevant statutory obligations.

#### 17. General provisions

17.1

The Customer will in connection with the Goods (to be) delivered, strictly and fully comply with national or international regulations and import, export and usage restrictions. The Customer will hold Schotman harmless with respect to any damage that may occur for Schotman because of violation of the provision as referred to in the previous sentence.

17.2

Two or more Customers who jointly entered into an agreement with Schotman will be jointly and severally liable to Schotman for the performance of the Agreement.

17.3

The Customer is held to provide its employees and the users of the Goods with all product notices, warnings, instructions, recommendations and similar information provided by Schotman.

17.4

The Buyer shall indemnify and hold harmless Schotman for any damage claim or other damaging effects of any nature or type, resulting from a breach of an obligation by the Customer under the Agreement, including these Terms and Conditions.

17.5

The Buyer cannot, without the prior written permission of an authorized representative from Schotman, assign, license or outsource (a part of) of its rights or obligations under the Agreement to any third party.

17.6

If any provision in this Agreement, including these Terms and Conditions, would turn out to be invalid, the remaining provisions will remain in effect in full. In that case, the Parties will replace the invalid provision by a valid provision in accordance with the aim and purport of this Agreement including these Terms and Conditions such that the new provision differs as little as possible from the invalid provision.

17.7

These Terms and Conditions are drafted in Dutch and English. In case of a dispute or difference of opinion about the content of these different versions, the Dutch text shall prevail and be binding on the Parties.

17.8

These Terms and Conditions have been filed with the Chamber of Commerce of Groningen under number 0010-6619.

17.9

In the event of any conflict between these Terms and Conditions and the provisions of the Agreement, the provisions of the Agreement will prevail.

#### 18. Applicable law and competent court

18.1

The Agreement is governed exclusively by the law of the Netherlands.

18.2

Any dispute that may arise in connection with this Agreement or following from any agreement resulting therefrom will initially be settled by the competent court in Assen.



© 2022 All rights reserved. SEP Europe is a registered trademark and the property of Schotman Elektro BV, its subsidiaries, and affiliated companies.



Weverstraat 4 . 9403 VJ . Assen

[www.schotmanelektro.nl](http://www.schotmanelektro.nl)  
[info@schotmanelektro.nl](mailto:info@schotmanelektro.nl)  
telefoon : 088 - 5460735

