

CASCADE DESIGNS®

# 2026 WORKBOOK

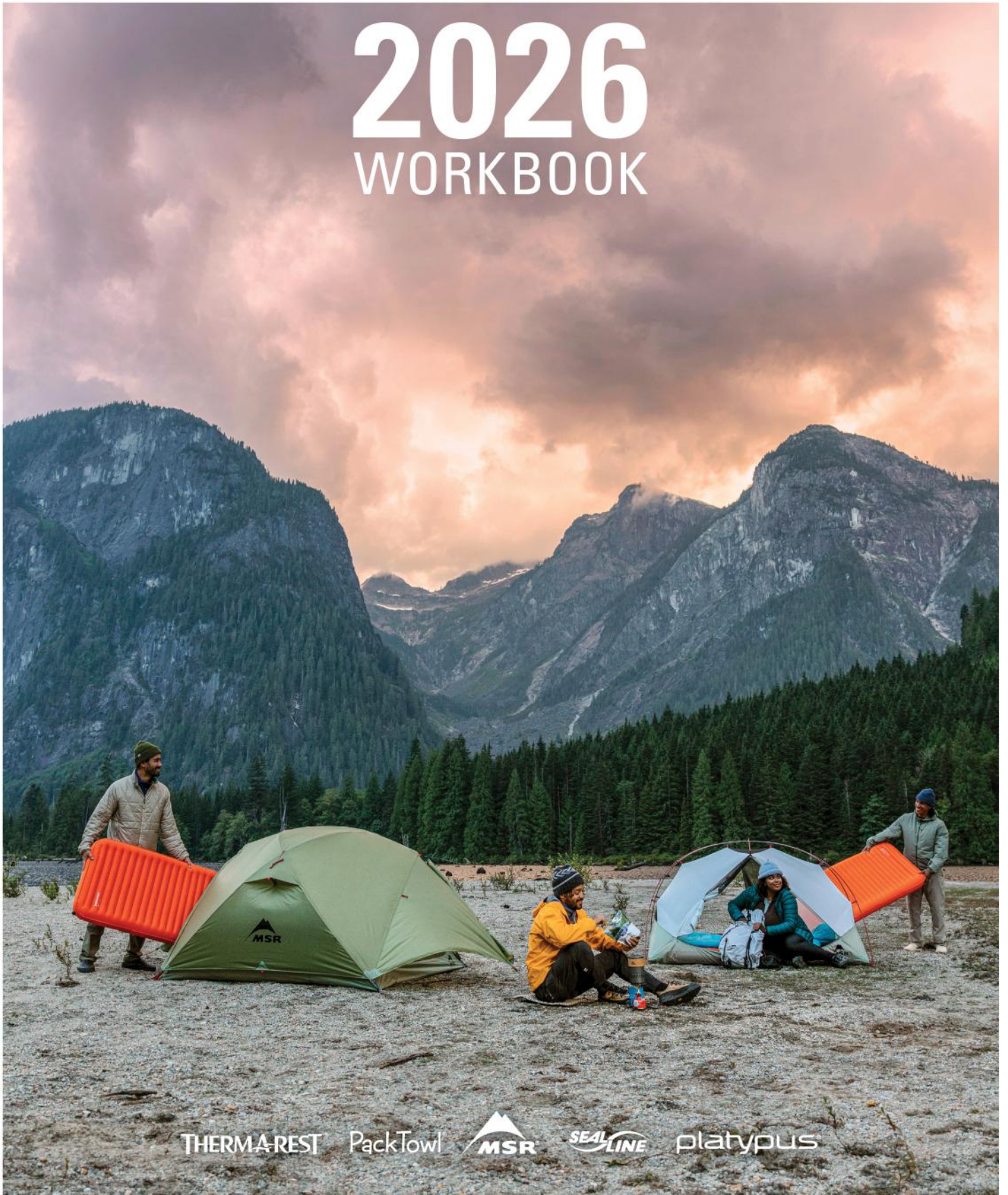

THERM-A-REST

PackTowl



SEAL LINE

platypus

# THERMA-REST®

THE BEST DAYS  
START AND END WITH  
THERM-A-REST



# THERMA-REST® UPDATED FOR 2026



## **BOOST 650™ SLEEPING BAG**

The award-winning Boost is now available in a Regular Wide size, increasing the appeal of this already versatile bag.



## **PARSEC™ SLEEPING BAG**

With new colors and a down fill increase from 800 to 900 fill, the PFAS-free Parsec is even better in 2026.



## **CORUS™ QUILT**

The updated Corus is PFAS-free and comes in new colors for both temperature ratings.



## **TRAIL PRO™ & TRAIL PRO™ MAX**

A Therm-a-Rest staple, the Trail Pro gets a refresh with new shapes, colors and more sustainable fabric to decrease its ecological footprint.

# SLEEPING PAD TECHNOLOGY



## THERMACAPTURE™

An innovative, proprietary material that reflects radiant heat and minimizes heat loss without adding extra weight or bulk.



## TRIANGULAR CORE MATRIX™

Patented technology utilizes two stacked layers of triangular baffles to create a stable surface while minimizing heat loss.



## CONTOUR CORE MATRIX™

We modified our industry-best Triangular Core Matrix™ air pad construction with comfort-forward materials so that it contours, cushions, supports, insulates and still packs down small.



## PREMIUM STRETCH KNIT FABRIC

This durable knit fabric is base-layer soft and contours to your body—unlike the woven fabric of other pads—for a pressure-point-free cradling sensation.



## PRESSURE-MAPPING

We use pressure-sensitive measurements to vary the support in our pads to provide intentionally placed support and comfort.

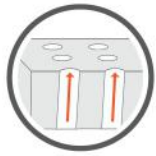

## DIE-CUT FOAM

A cut structure that allows for a lower density foam, which means a lighter weight and more compact pad.



## THERMAL FOAMS

Open cell foam structure traps air to deliver a higher R-value foam that provides consistent support and durability.

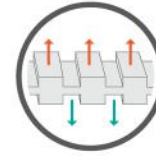

## STRATACORE™ FOAM

Yielding the best warmth-to-weight ratio of any self-inflating pad, StrataCore uses a continuous layer of thermal foam nestled between alternating ridges of air and foam.

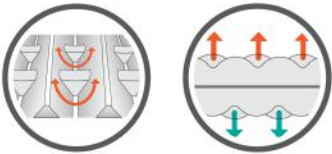

## RIDGEREST & Z LITE

Our unique patterns boost warmth with air-trapping peaks and valleys. Dual-density foam provides a durable and soft sleeping surface. The nesting Z Lite pattern maximizes compactibility.

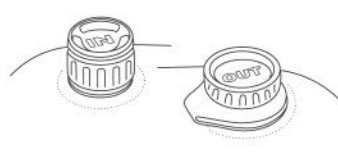

## TWINLOCK™ VALVE

The TwinLock makes using our larger, high-volume pads a dream by utilizing two high-flow one-way valves. One for inflation and one for deflation. Simple.



## WINGLOCK™ VALVE

Set off the sleeping surface for maximum utility, the high-flow one-way WingLock makes inflation and deflation a breeze.



## SOLUTION-DYED FABRIC

Solution dyeing reduces ecological impact by using less water and energy than traditional methods.

# SLEEPING PAD R-VALUE

## ITS ALL ABOUT FINDING THE RIGHT PAD

A standardized R-value may allow direct comparison of sleeping pad insulation across brands, but which R-value is the right one? Figuring out the R-value you need is a key step in finding your pad, which is why Therm-a-Rest developed an easy-to-read seasonality chart. We built this seasonality chart as a guide. Variables such as humidity, type of shelter and personal preference all effect how warm a sleeper is on any given night. No chart can replace experience for knowing the right R-value for a personalized sleep system.

### EXTENDED



VARIANCE ZONE  
ZONE DE TRANSITION

### SIMPLE CHART



# THERMAREST® SLEEPING PAD CATEGORIES



## FAST & LIGHT®

Our reliable Fast & Light pads are the top choice for alpinists, ultralight backpackers and anyone who needs to move quickly in the backcountry.

ULTRALIGHT  
COMPACT  
DEPENDABLE

## BACKPACKING COMFORT

Packing luxurious comfort well beyond their weight class, our Backpacking Comfort pads are designed for those who want the ability to go anywhere—near or far—and never compromise on a good night's sleep.

COMFORTABLE  
VERSATILE  
PACKABLE

## CAMP & COMFORT™

Whether it is base camping before a summit day or car camping with the family, our Camp & Comfort pads deliver maximum luxury when sleeping well is priority number one.

LUXURIOUS  
THICK  
WARM

## SIZE COMPARISON CHART

(FOR ALL PADS EXCLUDING NEOLOFT™)

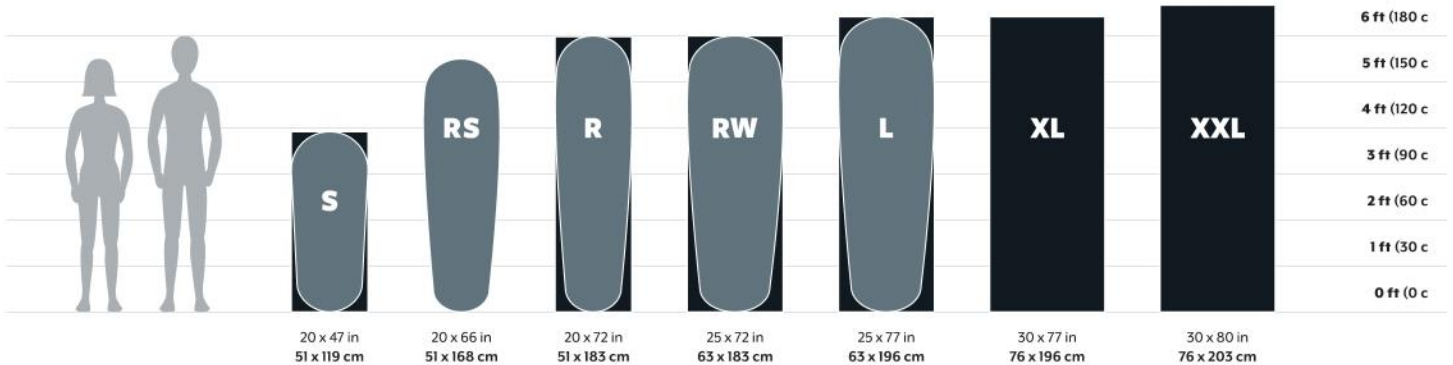

## SIZE COMPARISON CHART

(FOR NEOLOFT™ ONLY)

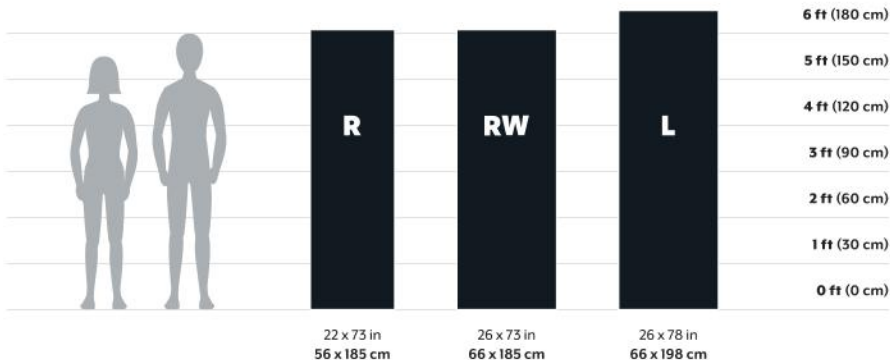

# 2026 SLEEPING PADS | LINE PLAN

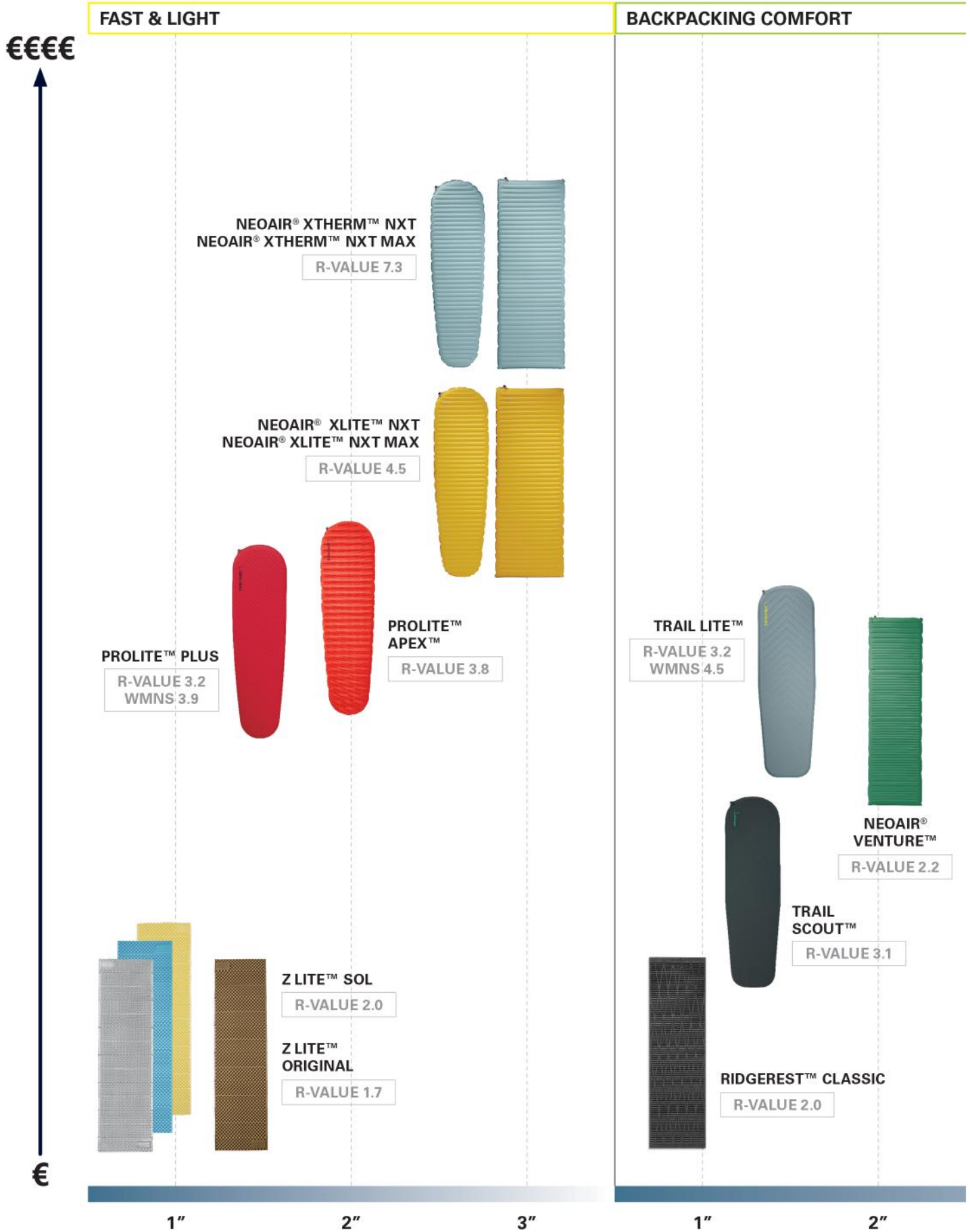

# 2026 SLEEPING PADS | LINE PLAN

## BACKPACKING COMFORT

## CAMP & COMFORT

€€€€



NEOLOFT™

R-VALUE 4.7



TRAIL PRO™  
TRAIL PRO™ MAX

R-VALUE 4.4



LUXURYMAP™

R-VALUE 6.0



BASECAMP™

R-VALUE 6.0



MONDOKING 3D

R-VALUE 7.0



3"

2"

3"

4"

€





Neptune

## NeoAir® XTherm™ NXT Sleeping Pad

With the best warmth-to-weight ratio of any sleeping pad ever created, the XTherm NXT is the top choice for alpinists, backpackers and ultralight travelers chasing cold-weather pursuits.

- **Warmest Air Pad in its Class:** Triangular Core Matrix™ construction and ThermaCapture™ technology deliver a 7.3 R-value, while minimizing weight and bulk.
- **Ultralight:** 15.5 oz (440 g) means warmth without the weight typically needed to stay warm in frigid conditions.
- **Premium Comfort:** At 3 inches (7.6 cm) thick the XTherm NXT delivers exceptional support and comfort.
- **Ultra-Packable:** Packed size rivals that of a conventional 1-liter bottle.
- **Durable:** 70D nylon fabric bottom resists punctures during extensive use.
- **Easy to Inflate & Deflate:** WingLock™ valve is easy to use in freezing conditions, features one-way inflation, and maximizes airflow to make inflating and deflating a breeze.
- Pump sack, stuff sack and repair kit included.

SIZE	Regular	Regular Wide	Large
SKU	14015	14016	14017
DIMENSIONS	51 x 183 x 7.6 cm (20 x 72 x 3 in)	64 x 183 x 7.6 cm (25 x 72 x 3 in)	64 x 196 x 7.6 cm (25 x 77 x 3 in)
WEIGHT	440 g (15.5 oz)	540 g (19 oz)	570 g (20 oz)
THICKNESS	7.6 cm (3 in)		
R-VALUE	7.3		



Neptune

## NeoAir® XTherm™ NXT MAX Sleeping Pad

With the best warmth-to-weight ratio of any sleeping pad ever created, the XTherm NXT is the top choice for alpinists, backpackers and ultralight travelers chasing cold-weather pursuits.

- **Warmest Air Pad in its Class:** Triangular Core Matrix™ construction and ThermaCapture™ technology deliver a 7.3 R-value, while minimizing weight and bulk.
- **Ultralight:** 23 oz (670 g) means warmth without the weight typically needed to stay warm in frigid conditions.
- **Premium Comfort:** At 3 inches (7.6 cm) thick the XTherm NXT delivers exceptional support and comfort.
- **Ultra-Packable:** Packed size rivals that of a conventional 1-liter bottle.
- **Durable:** 70D nylon fabric bottom resists punctures during extensive use.
- **Easy to Inflate & Deflate:** WingLock™ valve is easy to use in freezing conditions, features one-way inflation, and maximizes airflow to make inflating and deflating a breeze.
- **MAX Coverage:** Rectangular shape with extra width provides added coverage and enhanced comfort at camp.
- Pump sack, stuff sack and repair kit included.

SIZE	Regular Wide	Large
SKU	14018	14019
DIMENSIONS	64 x 183 x 7.6 cm (25 x 72 x 3 in)	64 x 196 x 7.6 cm (25 x 77 x 3 in)
WEIGHT	650 g (23 oz)	680 g (24 oz)
THICKNESS	7.6 cm (3 in)	
R-VALUE	7.3	



Solar Flare

## NeoAir® XLite™ NXT Sleeping Pad

Quieter, thicker and as iconic as ever, this is the next level of the most versatile all-around ultralight air pad.

- **Quieter:** 6x quieter than previous model thanks to a refinement in how the ThermaCapture™ layer is integrated into the Triangular Core Matrix™.
- **Premium Comfort:** At 3 inches (7.6 cm) thick the XLite NXT delivers exceptional support and comfort.
- **Ultralight:** 13 oz (370 g) drives pack weight down by minimizing the weight of an essential sleep system component.
- **Ultra-Packable:** Packs as small as a conventional 1-liter bottle.
- **Elite Warmth:** Triangular Core Matrix construction delivers a 4.5 R-value and class-leading warmth-to-weight ratio, making the XLite NXT ready for three-season and some winter pursuits.
- **Durability:** 30D ripstop nylon offers greater protection from punctures than the competition.
- **Easy to Inflate & Deflate:** WingLock™ valve is easy to use, features one-way inflation, and maximizes airflow to make inflating and deflating a breeze.
- Pump sack, stuff sack and repair kit included.

SIZE	Regular Short	Regular	Regular Wide	Large
SKU	14009	14010	14011	14012
DIMENSIONS	51 x 168 x 7.6 cm (20 x 66 x 3 in)	51 x 183 x 7.6 cm (20 x 72 x 3 in)	64 x 183 x 7.6 cm (25 x 72 x 3 in)	64 x 196 x 7.6 cm (25 x 77 x 3 in)
WEIGHT	330 g (11.5 oz)	370 g (13 oz)	450 g (16 oz)	480 g (17 oz)
THICKNESS	7.6 cm (3 in)			
R-VALUE	4.5			



Solar Flare

## NeoAir® XLite™ NXT MAX Sleeping Pad

Quieter, thicker and as iconic as ever, this is the next level of the most versatile all-around ultralight air pad.

- **Quieter:** 6x quieter than previous model thanks to a refinement in how the ThermoCapture™ layer is integrated into the Triangular Core Matrix™.
- **Premium Comfort:** At 3 inches (7.6 cm) thick the XLite NXT delivers exceptional support and comfort.
- **Ultralight:** 20 oz (570 g) drives pack weight down by minimizing the weight of an essential sleep system component.
- **Ultra-Packable:** Packs as small as a conventional 1-liter bottle.
- **Elite Warmth:** Triangular Core Matrix construction delivers a 4.5 R-value and class-leading warmth-to-weight ratio, making the XLite NXT ready for three-season and some winter pursuits.
- **Durability:** 30D ripstop nylon offers greater protection from punctures than the competition.
- **Easy to Inflate & Deflate:** WingLock™ valve is easy to use, features one-way inflation, and maximizes airflow to make inflating and deflating a breeze.
- **MAX Coverage:** Rectangular shape with extra width provides added coverage and enhanced comfort at camp.
- Pump sack, stuff sack and repair kit included.

SIZE	Regular Wide	Large
SKU	14013	14014
DIMENSIONS	64 x 183 x 7.6 cm (25 x 72 x 3 in)	64 x 196 x 7.6 cm (25 x 77 x 3 in)
WEIGHT	540 g (19 oz)	570 g (20 oz)
THICKNESS	7.6 cm (3 in)	
R-VALUE	4.5	



Heat Wave

## ProLite™ Apex™ Sleeping Pad

The pinnacle of self-inflating comfort and performance, the Apex offers unrivaled warmth without adding excess bulk and weight to your pack.

- **StrataCore™ Construction:** Yielding the best warmth-to-weight ratio of any self-inflating pad, StrataCore uses a continuous layer of thermal foam nestled between alternating ridges of air and foam.
- **Lightweight Comfort:** Our warmest ProLite ever allows three-season adventuring without weighing down a pack.
- **Rugged, Self-inflating Foam:** Expanding open-cell foam core self-inflates; top off with just a few breaths for personalized firmness on 2 inches (5 cm) of StrataCore loft.
- **Easily Fits in Your Pack:** Packs down small to easily find a place in your pack during fast and light adventures.
- **Easy to Inflate & Deflate:** WingLock™ valve is easy to use, features one-way inflation, and maximizes airflow to make inflating and deflating a breeze.
- Stuff sack included.

SIZE	Regular	Regular Wide	Large
SKU	14251	14252	14253
DIMENSIONS	51 x 183 x 5 cm (20 x 72 x 2 in)	64 x 183 x 5 cm (25 x 72 x 2 in)	64 x 196 x 5 cm (25 x 77 x 2 in)
WEIGHT	620 g (22 oz)	790 g (28 oz)	850 g (30 oz)
THICKNESS	5 cm (2 in)		
R-VALUE	3.8		



Cayenne

## ProLite™ Plus Sleeping Pad

Proven comfort, warmth and packability for three-season adventures.

- **Three-Season Warmth:** Thick, diagonal-cut foam offers efficient comfort.
- **Compact:** Lightweight foam boosts compressibility for easy packing.
- **Self-Inflating:** Expanding foam core self-inflates; top off with just a few breaths for personalized firmness.
- **WingLock™ Valve:** Our intuitive and dependable valve maximizes air flow for easier inflation and quicker deflation. Wings toggle for one-way inflation to save energy.

SIZE	Short	Regular Short	Regular	Large
SKU	14260	14263	14261	14262
DIMENSIONS	51 x 119 x 3.8 cm (20 x 47 x 1.5 in)	51 x 168 x 3.8 cm (20 x 66 x 1.5 in)	51 x 183 x 3.8 cm (20 x 72 x 1.5 in)	64 x 196 x 3.8 cm (25 x 77 x 1.5 in)
WEIGHT	450 g (16 oz)	650 g (23 oz)	650 g (23 oz)	880 g (31 oz)
THICKNESS	3.8 cm (1.5 in)			
R-VALUE	3.2	3.9	3.2	3.2

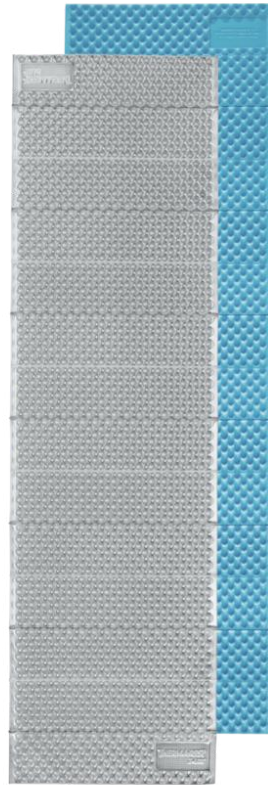

Blue / Silver



Limon / Silver



## Z Lite™ SOL Sleeping Pad

**Ultralight, super durable and boosted warmth, there's a reason it's a sleep system staple around the world.**

- **Advanced Warmth:** ThermaCapture™ surface reflects radiant heat back to your body, amplifying the warmth of the heat-trapping dimples by 15% (for best results, use reflective side face up).
- **Layer It:** Add 2.0 R-value and protection from punctures when you layer the Z Lite SOL under another sleeping pad.
- **Compact Design:** Accordion-style design quickly folds into a small, lightweight package.
- **Extra Durable:** Virtually indestructible thanks to dual-density closed-cell foam that provides lasting, economical comfort.

SIZE	Regular
SKU	13267, 06670
DIMENSIONS	51 x 183 x 2 cm (20 x 72 x 0.75 in)
WEIGHT	410 g (14 oz)
THICKNESS	2 cm (0.75 in)
R-VALUE	2.0



Oak/Anthracite

## Original Z Lite™ Sleeping Pad

**A backpacking icon, the Z Lite delivers dependable and lightweight comfort.**

- **Compact Design:** Accordion-style design quickly folds into a small, lightweight package.
- **Extra Durable:** Virtually indestructible thanks to dual-density closed-cell foam that provides lasting, economical comfort.
- **Layer It:** Add 1.7 R-value and protection from punctures when you layer the Z Lite under another sleeping pad.

SIZE	Regular
SKU	13612
DIMENSIONS	51 x 183 x 2 cm (20 x 72 x 0.75 in)
WEIGHT	410 g (14 oz)
THICKNESS	2 cm (0.75 in)
R-VALUE	2

MUST  
HAVE



Ember

## NeoLoft™ Sleeping Pad

Car camping comfort with backpacking specs—you've never slept like this in the backcountry.

- **Built to Backpack:** With a weight of 25 oz (Regular size), a packed size not much larger than a 1L water bottle and a 4.7 R-value, you can take car camping comfort deep into the backcountry.
- **3D Sidewall Construction:** A 4-inch-thick profile and a broad squared-off sleep surface is ideal for side sleepers, nighttime movers and any sleeper that likes comfort—so everyone, really.
- **ContourCore Matrix™:** We modified our industry-best Triangular Core Matrix™ air pad construction with comfort-forward materials so that it contours, cushions, supports, insulates and still packs down small.
- **Premium Stretch Knit Fabric:** This durable knit fabric is base-layer soft and contours to your body—unlike the woven fabric of other pads—for a pressure-point-free cradling sensation.
- **Side Rails:** Side rails cradle the sleeper in place and provide a tactile sense of the edge to minimize roll-offs and cold spots.
- **Advanced Valve System:** TwinLock™ Valve technology pairs with seam-sealed pump sack to make inflation a breeze and allows for precise firmness control.
- Stuff sack, high-volume pump sack and repair kit included.

SIZE	Regular	Regular Wide	Large
SKU	14157	14158	14159
DIMENSIONS	56 x 185 x 11.7 cm (22 x 73 x 4.6 in)	66 x 185 x 11.7 cm (26 x 73 x 4.6 in)	66 x 198 x 11.7 cm (26 x 78 x 4.6 in)
WEIGHT	710 g (25 oz)	850 g (30 oz)	910 g (32 oz)
THICKNESS	11.7 cm (4.6 in)		
R-VALUE	4.7		



Pine

## NeoAir® Venture™ Sleeping Pad

**Durable NeoAir comfort and packability at an exceptional value.**

- **Insulate Performance:** WaveCore™ construction provides twice the warmth of uninsulated air sleeping pads.
- **Compact:** Insulated without the use of bulky fill materials allows it to pack small.
- **Comfortable:** 2 inches (5 cm) of loft and horizontal baffles provide maximum stability and support.
- **Durable:** Tough 50D polyester and proven airtight coatings deliver reliable long-term performance.
- **Easy to Inflate & Deflate:** WingLock™ valve is easy to use, features one-way inflation, and maximizes airflow to make inflating and deflating a breeze.
- Pump sack, stuff sack and repair kit included.

SIZE	Regular	Large
SKU	14025	14026
DIMENSIONS	51 x 183 x 5 cm (20 x 72 x 2 in)	64 x 196 x 5 cm (25 x 77 x 2 in)
WEIGHT	570 g (20 oz)	740 g (26 oz)
THICKNESS	5 cm (2 in)	
R-VALUE	2.2	



UPDATED



Tide

## Trail Pro™ Sleeping Pad

**Plush stretch knit top fabric and a thick, supportive open-cell foam core deliver a singular blend of big comfort and packability.**

- **StrataCore™ Construction:** Yielding an impressive warmth-to-weight ratio for self-inflating foam, StrataCore uses a continuous layer of thermal foam nestled between alternating ridges of air and foam.
- **Premium Self-Inflating Comfort:** Ultra-plush stretch-knit fabric wrapped around 3 inches of premium foam provides localized support and superior loft.
- **Easy to Pack:** StrataCore construction allows the pad to compress into an easy- to-carry size.
- **Easy Inflate & Deflate:** WingLock™ valve is easy to use, features one-way inflation and maximizes airflow to make inflating and deflating a breeze.
- **Solution-Dyed Bottom Fabric:** Solution dyeing reduces ecological impact by using less water and energy than traditional methods.
- Stuff sack included.

SIZE	Regular	Regular Wide	Large
SKU	14160	14161	14389
DIMENSIONS	51 x 183 x 76 cm (20 x 72 x 3 in)	64 x 183 x 76 cm (25 x 72 x 3 in)	64 x 196 x 76 cm (25 x 77 x 3 in)
WEIGHT	850 g (30 oz)	1080 g (38 oz)	1110 g (39 oz)
THICKNESS	7.6 cm (3 in)		
R-VALUE	4.4		



UPDATED



Tide

## Trail Pro™ MAX Sleeping Pad

**Plush stretch knit top fabric and a thick, supportive open-cell foam core deliver a singular blend of big comfort and packability.**

- **StrataCore™ Construction:** Yielding an impressive warmth-to-weight ratio for self-inflating foam, StrataCore uses a continuous layer of thermal foam nestled between alternating ridges of air and foam.
- **Premium Self-Inflating Comfort:** Ultra-plush stretch-knit fabric wrapped around 3 inches of premium foam provides localized support and superior loft.
- **Easy to Pack:** StrataCore construction allows the pad to compress into an easy- to-carry size.
- **Easy Inflate & Deflate:** WingLock™ valve is easy to use, features one-way inflation and maximizes airflow to make inflating and deflating a breeze.
- **Solution-Dyed Bottom Fabric:** Solution dyeing reduces ecological impact by using less water and energy than traditional methods.
- **MAX Coverage:** Rectangular shape with extra width provides added coverage and enhanced comfort at camp.
- Stuff sack included.

SIZE	Regular Wide	Large
SKU	14162	14163
DIMENSIONS	64 x 183 x 7.6 cm (25 x 72 x 3 in)	64 x 196 x 7.6 cm (25 x 77 x 3 in)
WEIGHT	1160 g (41 oz)	1240 g (43 oz)
THICKNESS	7.6 cm (3 in)	
R-VALUE	4.4	



Trooper

## Trail Lite™ Sleeping Pad

**Outstanding combination of comfort, compactness and essential warmth.**

- **Versatile:** Light and compact enough for backpacking without sacrificing the comfort you desire.
- **Die-Cut Foam Construction:** Lightweight and warm, die-cut construction provides compact performance, allowing you to save room for other gear and essentials.
- **Easy to Use:** Foam core self-inflates and rolls up small for easy packing.
- **Women's Version:** Features added warmth for cold sleepers.
- **Easy to Inflate & Deflate:** WingLock™ valve is easy to use, features one-way inflation, and maximizes airflow to make inflating and deflating a breeze.
- Stuff sack included.

SIZE	Regular Short	Regular	Large
SKU	14259	14257	14258
DIMENSIONS	51 x 168 x 3.8 cm (20 x 66 x 1.5 in)	51 x 183 x 3.8 cm (20 x 72 x 1.5 in)	64 x 196 x 3.8 cm (25 x 77 x 1.5 in)
WEIGHT	740 g (22 oz)	740 g (22 oz)	1050 g (37 oz)
THICKNESS	3.8 cm (1.5 in)		
R-VALUE	4.5	3.2	3.2



Deep Forest

## Trail Scout™ Sleeping Pad

Topped with a woven fabric to boost comfort, the Trail Scout is the de facto pad for new campers and backpackers stepping up their game and looking for longterm value.

- **Get Started Outdoors:** Provides the essential comfort you need at an exceptional value.
- **Portable:** Packs down to fit in the included stuff sack, allowing you to take it anywhere.
- **Lightweight:** Keeps your pack light and easy to carry, allowing you to go further.
- **Self-Inflating:** Open-cell foam core self-inflates; top off with just a few breaths for personalized firmness.
- **Easy Inflate & Deflate:** WingLock™ valve is easy to use, features one-way inflation and maximizes airflow to make inflating and deflating a breeze.
- Stuff sack included.

SIZE	Regular	Large
SKU	14169	14170
DIMENSIONS	51 x 183 x 2.5 cm (20 x 72 x 1 in)	64 x 196 x 2.5 cm (25 x 77 x 1 in)
WEIGHT	680 g (24 oz)	940 g (33 oz)
THICKNESS	2.5 cm (1 in)	
R-VALUE	3.1	



Poseidon Blue

## TourLite™ Sleeping Pad

Warm, comfortable backpacking mattress.

- **Comfortable:** Air and open-cell foam combine to provide superior warmth and comfort.
- **Thoughtful Design:** Low-slip top fabric keeps you in place, while bottom material is durable and waterproof.
- **Reliable Valve:** Classic valve allows for quick inflation and deflation and is dirt-proof and cold-weather safe.
- Stuff sack included.

SIZE	Regular	Large
SKU	13486	13487
DIMENSIONS	51 x 183 x 3 cm (20 x 72 x 1.2 in)	64 x 196 x 3 cm (25 x 77 x 1.2 in)
WEIGHT	790 g (28 oz)	1000 g (35 oz)
THICKNESS	3 cm (1.2 in)	
R-VALUE	4,1	



Charcoal

## RidgeRest® Classic Sleeping Pad

A timeless and high-utility backpacking pad for simplified comfort at camp.

- **Light & Durable:** Virtually indestructible and light enough to carry anywhere.
- **High-Performance Design:** Supportive peaks and heat-trapping valleys provide essential comfort and warmth.

SIZE	Regular	Large
SKU	06432	06433
DIMENSIONS	51 x 183 x 1.5 cm (20 x 72 x 0.625 in)	64 x 196 x 1.5 cm (25 x 77 x 0.625 in)
WEIGHT	400 g (14 oz)	540 g (19 oz)
THICKNESS	1.5 cm (0.63 in)	
R-VALUE	2.0	

MUST  
HAVE



Marine Blue

## MondoKing™ 3D Sleeping Pad

Built with StrataCore construction, the MondoKing lets you camp like royalty with its plush 3D shape.

- **Stable Comfort:** 4.25 inches (11 cm) of luxurious foam-stabilized loft bring the comfort of home to the outdoors.
- **Luxurious Fabric:** Stretch knit fabric provides a plush surface and optimizes support by locally stretching to conform to your body.
- **StrataCore™ Construction:** Yielding an impressive warmth-to-weight ratio, StrataCore uses a continuous layer of thermal foam nestled between alternating ridges of air and foam.
- **Giant Sleep Surface:** Vertical sidewalls maximize useable sleep surface.
- **Incredibly Warm:** Foam core delivers all-season warmth to assure great rest on any given night.
- **Easy to Pack:** StrataCore construction allows the pad to easily compress, roll up and pack away.
- **TwinLock™ Valve:** Utilizing two one-way valves—one for inflation and one for deflation—the TwinLock valve system makes setting up and breaking camp a breeze.
- Pump stuff sack included.

SIZE	Large	XXL
SKU	14020	14021
DIMENSIONS	64 x 196 x 11 cm (25 x 77 x 4.25 in)	76 x 203 x 11 cm (30 x 80 x 4.25 in)
WEIGHT	1990 g (70 oz)	2500 g (88 oz)
THICKNESS	11 cm (4.25 in)	
R-VALUE	7	



Poseidon Blue

## LuxuryMap™ Sleeping Pad

Luxurious and durable, the self-inflating foam core provides three inches of comfort in all the right places thanks to targeted pressure mapping.

- **Plush Materials:** Soft, stretch knit surface feels great next to skin.
- **Targeted Comfort:** Unique pressure-mapped pattern delivers support and softness.
- **Extra Thick:** 3 inches (7.6 cm) of bump-swallowing loft.
- **Self-Inflating:** Compressible foam core expands to inflate; add just a few breaths for your desired firmness.
- **TwinLock™ Valve:** Utilizing two one-way valves—one for inflation and one for deflation—the TwinLock valve system makes setting up and breaking camp a breeze.
- Stuff sack included.

SIZE	Regular	Large	Extra Large
SKU	14027	14028	14029
DIMENSIONS	51 x 183 x 7.6 cm (20 x 72 x 3 in)	64 x 196 x 7.6 cm (25 x 77 x 3 in)	76 x 196 x 7.6 cm (30 x 77 x 3 in)
WEIGHT	1480 g (52 oz)	1900 g (67 oz)	2330 g (82 oz)
THICKNESS	7.6 cm (3 in)		
R-VALUE	6		



Poseidon Blue

## BaseCamp™ Sleeping Pad

A tried-and-true pad built to offer supreme comfort in the frontcountry.

- **Thick:** 2 inches (5 cm) of thickness provides a high level of warmth and support.
- **Plush Fabrics:** Light, soft fabrics make this mattress exceptionally comfortable.
- **Premium Self-Inflating Foam:** Solid foam creates a warmer and more stable sleep surface, while compressible foam core expands when unpacked for easy self-inflation.
- **Durable:** Sturdy, classic design provides an outstanding value.
- **Easy to Inflate & Deflate:** WingLock™ valve is easy to use, features one-way inflation, and maximizes airflow to make inflating and deflating a breeze.
- Stuff sack included.

SIZE	Regular	Large	Extra Large
SKU	14030	14031	14032
DIMENSIONS	51 x 183 x 5 cm (20 x 72 x 2 in)	64 x 196 x 5 cm (25 x 77 x 2 in)	76 x 196 x 5 cm (30 x 77 x 2 in)
WEIGHT	1140 g (40 oz)	1530 g (54 oz)	1820 g (64 oz)
THICKNESS	5 cm (2 in)		
R-VALUE	6		



Green

## BlockerLite™ Pump Sack

A versatile dry stuff sack for inflating a sleeping pad or protecting your gear.

- **Dual Function:** Inflates air pads and works as a dry bag to protect your gear..

SIZE	One Size
SKU	13228
DIMENSIONS	14 x 26 x 61 cm (5.5 x 10 x 24 in)
WEIGHT	150 g (5 oz)



Clear

## Instant Field Repair Kit

Everything you need to perform on-the-fly repairs to your mattress.

- **Includes:** Glue Dots™ (colored and clear), clear adhesive patches, alcohol prep pads, cleaning supplies.
- \*Not for use with stretch knit fabric.

SIZE	One Size
SKU	03588
DIMENSIONS	13 x 15 x 2.5 cm (4 x 6 x 1 in)
WEIGHT	60 g (2 oz)



Blue / Silver

## WingLock™ Valve Repair Kit

The do-it-yourself kit for replacing a high-performance WingLock valve.

- **Includes:** Replacement WingLock valve, tube of lubricant.

SIZE	One Size
SKU	13285
DIMENSIONS	5 x 5 x 5 cm (2 x 2 x 2 in)
WEIGHT	120 g (4 oz)



Clear

## Classic Valve Repair Kit

The do-it-yourself kit for replacing a Therm-a-Rest classic valve.

- **Includes:** Replacement Classic valve, tube of adhesive.

SIZE	One Size
SKU	13312
DIMENSIONS	2 x 2.5 x 2 cm (0.75 x 1 x 0.75 in)
WEIGHT	20 g (0.33 oz)



NA

## Permanent Home Repair Kit

For the larger repairs of your mattress. Requires 8-12 hour cure time.

- **Includes:** Pressure adhesive patches, alcohol prep pads, wooden applicator, 25 oz tube of adhesive.

<b>SIZE</b>	<b>One Size</b>
<b>SKU</b>	08490
<b>DIMENSIONS</b>	
<b>WEIGHT</b>	

**THERM-A-REST SLEEPING PAD SPECIFICATIONS**

AIR INFLATE	SIZE	SKU	DIMENSIONS	WEIGHT	FABRIC	THICKNESS	COMPRESSED DIMENSIONS	R-VALUE
NeoLoft™	R	14157	56 x 185 cm (22 x 73 in)	710 g (1 lb 9 oz)	Stretch Knit 50D Polyester/ 75D Polyester Solution Dyed	11.7 cm (4.6 in)	24 x 14 cm (9.5 x 5.7 in)	4.7
	RW	14158	66 x 185 cm (26 x 73 in)	850 g (1 lb 14 oz)		11.7 cm (4.6 in)	29 x 15 cm (11 x 6 in)	4.7
	L	14159	66 x 198 cm (26 x 78 in)	910 g (2 lb)		11.7 cm (4.6 in)	29 x 15 cm (11 x 6 in)	4.7
NeoAir® Venture™	R	14025	51 x 183 cm (20 x 72 in)	540 g (1 lb 3 oz)	50D Polyester	5 cm (2 in)	28 x 17 cm (11 x 6.6 in)	2.2
	L	14026	64 x 196 cm (25 x 77 in)	740 g (1 lb 10 oz)		5 cm (2 in)	33 x 17 cm (13 x 6.7 in)	2.2
NeoAir® XTherm™ NXT	R	14015	51 x 183 cm (20 x 72 in)	440 g (15.5 oz)	30D HT Nylon/70D Nylon	7.6 cm (3 in)	23 x 11 cm (9.0 x 4.5 in)	7.3
	RW	14016	64 x 183 cm (25 x 72 in)	540 g (1 lb 3 oz)		7.6 cm (3 in)	28 x 13 cm (11.0 x 5.0 in)	7.3
	L	14017	64 x 196 cm (25 x 77 in)	570 g (1 lb 4 oz)		7.6 cm (3 in)	28 x 13 cm (11.0 x 5.0 in)	7.3
NeoAir® XTherm™ NXT MAX	RW	14018	64 x 183 cm (25 x 72 in)	650 g (1 lb 7 oz)	30D HT Nylon/70D Nylon	7.6 cm (3 in)	28 x 13 cm (11.0 x 5.0 in)	7.3
	L	14019	64 x 196 cm (25 x 77 in)	680 g (1 lb 8 oz)		7.6 cm (3 in)	28 x 13 cm (11.0 x 5.0 in)	7.3
NeoAir® XLite™ NXT	RS	14009	51 x 168 cm (20 x 66 in)	330 g (11.5 oz)	30D HT Nylon	7.6 cm (3 in)	23 x 10 cm (9 x 4.0 in)	4.5
	R	14010	51 x 183 cm (20 x 72 in)	370 g (13 oz)		7.6 cm (3 in)	23 x 10 cm (9 x 4.0 in)	4.5
	RW	14011	64 x 183 cm (25 x 72 in)	450 g (16 oz)		7.6 cm (3 in)	28 x 12 cm (11 x 4.6 in)	4.5
	L	14012	64 x 196 cm (25 x 77 in)	480 g (1 lb 1 oz)		7.6 cm (3 in)	28 x 12 cm (11 x 4.6 in)	4.5
NeoAir® XLite™ NXT MAX	RW	14013	64 x 183 cm (25 x 72 in)	540 g (1 lb 3 oz)	30D HT Nylon	7.6 cm (3 in)	28 x 12 cm (11 x 4.6 in)	4.5
	L	14014	64 x 196 cm (25 x 77 in)	570 g (1 lb 4 oz)		7.6 cm (3 in)	28 x 12 cm (11 x 4.6 in)	4.5
CLOSED CELL	SIZE	SKU	DIMENSIONS	WEIGHT	MATERIAL	THICKNESS	COMPRESSED DIMENSIONS	R-VALUE
RidgeRest® Classic	R	06432	51 x 183 cm (20 x 72 in)	400g (14 oz)	Cross Linked Polyethylene	1.5 cm (.62 in)	51 x 20 cm (20 x 8 in)	2.0
	L	06433	64 x 196 cm (25 x 77 in)	540g (1 lb 3 oz)		1.5 cm (.62 in)	63 x 22 cm (25 x 8.5 in)	2.0
Z Lite™ SOL / Z Lite™	R	06670	51 x 183 cm (20 x 72 in)	410 g (14 oz)	Cross Linked Polyethylene	2 cm (.75 in)	51 x 13 x 14 cm (20 x 5 x 5.5 in)	2.0
	R	13267	51 x 183 cm (20 x 72 in)	410 g (14 oz)		2 cm (.75 in)	51 x 13 x 14 cm (20 x 5 x 5.5 in)	2.0
	R	13612	51 x 183 cm (20 x 72 in)	410 g (14 oz)		2 cm (.75 in)	51 x 13 x 14 cm (20 x 5 x 5.5 in)	1.7
SELF INFLATE	SIZE	SKU	DIMENSIONS	WEIGHT	FABRIC	THICKNESS	COMPRESSED DIMENSIONS	R-VALUE
ProLite™ Apex™	R	14251	51 x 183 cm (20 x 72 in)	620 g (1 lb 6 oz)	50D Polyester	5 cm (2 in)	28 x 17 cm (11 x 6.8 in)	3.8
	RW	14252	64 x 183 cm (25 x 72 in)	790 g (1 lb 12 oz)		5 cm (2 in)	33 x 18 cm (13 x 7 in)	3.8
	L	14253	64 x 196 cm (25 x 77 in)	850 g (1 lb 14 oz)		5 cm (2 in)	33 x 18 cm (13 x 7 in)	3.8
ProLite™ Plus / ProLite™ Plus Women's	S	14260	51 x 119 cm (20 x 47 in)	450 g (16 oz)	50D Mini Hex Polyester	3.8 cm (1.5 in)	28 x 15 cm (11 x 5.8 in)	3.2
	R	14261	51 x 183 cm (20 x 72 in)	650 g (1 lb 7 oz)		3.8 cm (1.5 in)	28 x 17 cm (11 x 6.8 in)	3.2
	L	14262	64 x 196 cm (25 x 77 in)	880 g (1 lb 15 oz)		3.8 cm (1.5 in)	33 x 18 cm (13 x 7 in)	3.2
	WR	14263	51 x 168 cm (20 x 66 in)	650 g (1 lb 7 oz)		3.8 cm (1.5 in)	28 x 17 cm (11 x 6.8 in)	3.9
Trail Pro™	R	14160	51 x 183 cm (20 x 72 in)	850 g (1 lb 14 oz)	50D Polyester Stretch Knit / 75D Polyester Solution Dyed	7.6 cm (3 in)	28 x 22 cm (11 x 8.8 in)	4.4
	RW	14161	64 x 183 cm (25 x 72 in)	1080 g (2 lb 6 oz)		7.6 cm (3 in)	33 x 23 cm (13 x 9.3 in)	4.4
	L	14389	64 x 196 cm (25 x 77 in)	1110g (2 lb 7 oz)		7.6 cm (3 in)	33 x 23 cm (13 x 9.3 in)	4.4
Trail Pro™ MAX	RW	14162	64 x 183 cm (25 x 72 in)	1080 g (2 lb 9 oz)	50D Polyester Stretch Knit / 75D Polyester Solution Dyed	7.6 cm (3 in)	33 x 23 cm (13 x 9.3 in)	4.4
	L	14163	64 x 196 cm (25 x 77 in)	1240 g (2 lb 11 oz)		7.6 cm (3 in)	33 x 23 cm (13 x 9.3 in)	4.4
Trail Lite™/ Trail Lite™ Women's	R	14257	51 x 183 cm (20 x 72 in)	740 g (1 lb 10 oz)	50D Polyester	3.8 cm (1.5 in)	28 x 20 cm (11 x 7.8 in)	3.2
	L	14258	64 x 196 cm (25 x 77 in)	1050 g (2 lb 5 oz)		3.8 cm (1.5 in)	33 x 21 cm (13 x 8.3 in)	3.2
	WR	14259	51 x 168 cm (20 x 66 in)	740 g (1 lb 10 oz)		3.8 cm (1.5 in)	28 x 20 cm (11 x 7.8 in)	4.5
Trail Scout™	R	14169	51 x 183 cm (20 x 72 in)	680 g (1 lb 8 oz)	75D Polyester	2.5 cm (1 in)	28 x 20 cm (11 x 7.8 in)	3.1
	L	14170	64 x 196 cm (25 x 77 in)	940 g (2 lb 1 oz)		2.5 cm (1 in)	33 x 20 cm (13 x 8 in)	3.1
MondoKing™ 3D	L	14020	64 x 196 cm (25 x 77 in)	1990 g (4 lb 6 oz)	50D Polyester Stretch Knit / 75D Polyester	11 cm (4.25 in)	66 x 26 cm (26 x 10.3 in)	7.0
	XL	14021	76 x 203 cm (30 x 80 in)	2500 g (5 lb 8 oz)		11 cm (4.25 in)	79 x 26 cm (31 x 10 in)	7.0
LuxuryMap™	R	10427	51 x 183 cm (20 x 72 in)	1480 g (3 lb 4 oz)	50D Polyester Stretch Knit / 75D Polyester	7.6 cm (3 in)	54 x 24 cm (21 x 9.5 in)	6.0
	L	14028	64 x 196 cm (25 x 77 in)	1900 g (4 lb 3 oz)		7.6 cm (3 in)	66 x 24 cm (26 x 9.5 in)	6.0
	XL	14029	76 x 196 cm (30 x 77 in)	2330 g (5 lb 2 oz)		7.6 cm (3 in)	79 x 25 cm (31 x 10 in)	6.0
BaseCamp™	R	14030	51 x 183 cm (20 x 72 in)	1140 g (2 lb 8 oz)	75D Polyester	5 cm (2 in)	54 x 22 cm (21 x 8.5 in)	6.0
	L	14031	64 x 196 cm (25 x 77 in)	1530 g (3 lb 6 oz)		5 cm (2 in)	66 x 23 cm (26 x 9 in)	6.0
	XL	14032	76 x 196 cm (30 x 77 in)	1820 g (4 lb)		5 cm (2 in)	79 x 23 cm (31 x 9 in)	6.0

# THERMAREST® SLEEPING BAGS, QUILTS & BLANKETS



## FAST & LIGHT®

Designed to keep you moving quickly in the hills, our Fast & Light sleeping bags provide you with a lighter pack than you ever thought possible.

## BACKPACKING COMFORT

The result of premium materials and pioneering innovation, our Backpacking Comfort sleeping bags are light, compact and spacious to give unrestricted sleep to unrestricted explorers.

## CAMP & COMFORT™

Our versatile, insulated blankets are designed for extra warmth during any adventure.

## WARMTH YOU CAN TRUST

Our on-site manikin and cold chamber allow us to design products that will perform in the field. Our chamber and independent testing provide temperature ratings for our products. All hooded sleeping bags above 10 degrees Fahrenheit get rated in accordance to EN (European Norm) 13537 and ISO 23537. Our blankets, quilts and non-hooded sleeping bags are given a suggested comfort and limit range that differs slightly from traditional EN ratings, because these products require extra insulation for your head and integration with a mattress. Use these charts to understand the warmth you can expect from Therm-a-Rest products.

**Comfort Range & Rating:** This is the lowest recommended temperature for a "standard" woman (25 yo, 132 lb (60 kg), 5'2" (157 cm)).

**Transition Range & Limit Rating:** This is the lowest recommended temperature for a "standard" man (25 yo, 154 lb (70 kg) and 5'7" (170 cm)).

**Risk Range & Rating:** The sleeping bag should only be used in this range in an emergency, or by those with ample experience in augmenting a bag's warmth.

TEMPERATURE RATING IN ACCORDANCE TO EN 13537 / ISO 23537					
COMFORT RANGE	32° F 0° C	TRANSITION RANGE	LIMIT 20° F -6° C	RISK RANGE	-12° F -24° C
COMFORT RANGE	41° F 5° C	TRANSITION RANGE	LIMIT 32° F 0° C	RISK RANGE	5° F -15° C
COMFORT RANGE	52° F 11° C	TRANSITION RANGE	LIMIT 45° F 7° C	RISK RANGE	21° F -6° C

RECOMMENDED TEMPERATURES			
COMFORT	-4° F -20° C	LIMIT	-20° F -30° C
COMFORT	14° F -10° C	LIMIT	0° F -18° C
COMFORT	32° F 0° C	LIMIT	20° F -6° C
COMFORT	41° F 5° C	LIMIT	32° F 0° C

# SLEEPING BAG TECHNOLOGY



## 100% RECYCLED NYLON

Soft-to-the-touch 20D nylon that is 100% recycled and Global Recycle Standard (GRS) certified.



## WARMZIP™

Patent-pending center zipper design reduces the bag's internal space and tucks insulation around the sleeper to boost warmth by up to 10F/6C.



## HYDROPHOBIC TREATED DOWN

Humanely sourced down insulation with superior heat-retention properties in wet conditions.



## RESPONSIBLE DOWN STANDARD

All of our down is certified to the Responsible Down Standard so that you can sleep easy knowing that the waterfowl have been treated humanely.



## ERALOFT™ SYNTHETIC INSULATION

Hollow fibers boost heat capabilities while shedding weight. Compressible synthetic insulation repels water and possesses excellent temperature regulation.

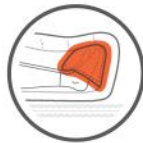

## TOE-ASIS™ FOOT WARMER

A baffled pocket of insulation helps rapidly warm cold feet inside of our ergonomic footbox.



## ZONED INSULATION

Intentionally placed insulation puts fill exactly where you need it, maximizing thermal properties while reducing weight.

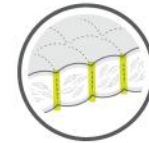

## BOX BAFFLED CONSTRUCTION

To maximize thermal efficiency in key areas, we use mesh box baffles to boost loft and eliminate cold spots at the seams of the sleeping bag or quilt.

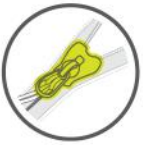

## YKK® ANTI-SNAG ZIPPER

Special slider design makes midnight ventilation a breeze by preventing annoying and costly snags on the fabric.



## QUILT & BLANKET LOOPS

Most of our bags are equipped with quilt and blanket loops, allowing you to securely attach extra insulation to customize your sleep system.

## BETTER SLEEP GUARANTEE

For 50 years our designs have been guided by a singular purpose: better sleep outside. Whether it's deep in the backcountry or in the back of a van, you should be getting better sleep in one of our sleeping bags or quilts, which is why we have the Better Sleep Guarantee. If you are not completely satisfied with your sleeping bag or quilt, return it within three months and we will give you a full refund, no questions asked.

Only available in the USA and Canada.



# 2026 SLEEPING BAGS, QUILTS & BLANKETS | LINE PLAN

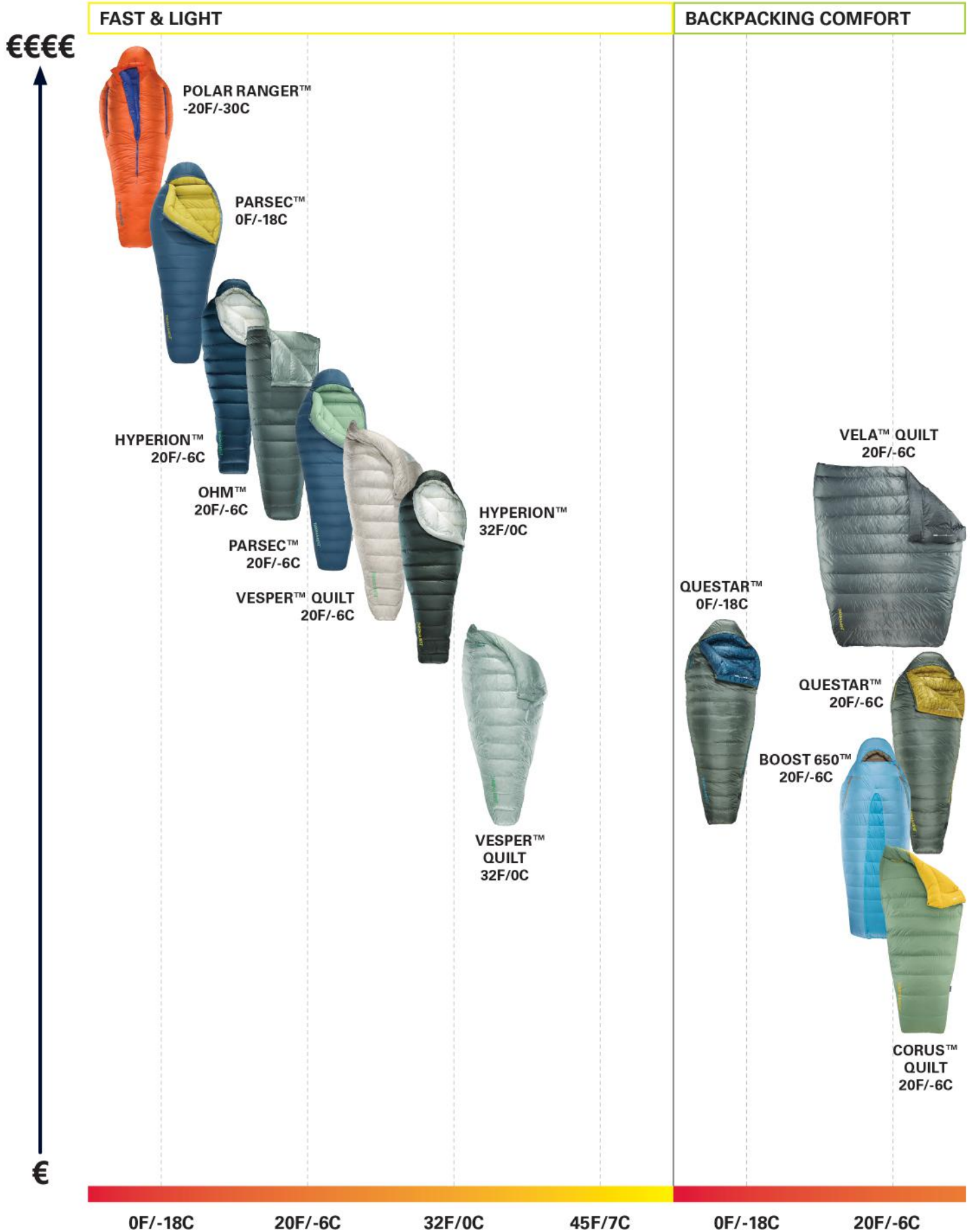

# 2026 SLEEPING BAGS, QUILTS & BLANKETS | LINE PLAN

## BACKPACKING COMFORT

## CAMP & COMFORT

€€€€



VELA™ QUILT  
32F/0C



QUESTAR™  
32F/0C



BOOST 650™  
32F/0C



CORUS™  
QUILT  
32F/0C

HONCHO  
PONCHO™



HONCHO  
PONCHO™  
DOWN



ARGO™  
BLANKET



STELLAR™  
BLANKET



HONCHO  
PONCHO™ KIDS

€

32F/0C

45F/7C

UPDATED



Flame

## Polar Ranger™ -20F/-30C Sleeping Bag

Designed from years of expedition experience, the award-winning Polar Ranger is equipped to take on the world's most extreme conditions and make them livable.

- **Premium Performance:** 900-fill hydrophobic down, premium shell and lining fabric provide exceptional compressibility and warmth-to-weight ratio.
- **High-Performance Sustainability:** Shell and liner are made of a soft, lightweight, durable and 100% recycled nylon.
- **Full-Featured Snorkel Hood:** Shorter, stiffer snorkel allows easy breathing and ventilates exhaled moisture; magnetic closure keeps cross-drafts at bay and eases entry and exit.
- **Refined Fit:** Tested and perfected in our onsite cold chamber, added girth and precise down distribution achieve optimal thermal efficiency and comfort.
- **Additional Features:** Toe-asis™ Foot Warmer Pocket, overstuffed draft tubes, quilt and blanket loops, cinchable draft collar, and a YKK anti-snap zipper.
- Compression sack and storage sack included.

SIZE	Regular	Long
SKU	14212	14213
DIMENSIONS	81 x 206 x 17 cm (32 x 81 x 6.5 in)	86 x 218 x 17 cm (34 x 86 x 6.5 in)
WEIGHT	1480 g (52 oz)	1560 g (55 oz)
FILL	800-Fill PFAS-Free Hydrophobic Duck Down, RDS	
FILL WEIGHT	965 g (34 oz)	1070 g (37.7 oz)
RECOMMENDED TEMPERATURE	EN COMFORT: -4 °F / -20 °C EN LIMIT: -20 °F / -30 °C	
GIRTH (SHOULDER / HIP / FOOT)	163 / 150 / 117 cm (64 / 59 / 46 in)	173 / 152 / 130 cm (68 / 60 / 51 in)
FABRIC	100% Recycled 20D Nylon Ripstop, DWR	
PACKED SIZE	22 x 25 cm (8.5 x 10 in)	



UPDATED



Reflecting Pond

## Parsec™ 20F/-6C Sleeping Bag

Updated with premium 900-fill down and a refined baffle structure, this high-performance bag is ideal for backcountry pursuits where you want to travel fast and light.

- **Ultralight Warmth:** More down than ever before provides exceptional warmth. Premium 900-fill hydrophobic down is RDS-certified and PFAS-free.
- **High-Performance Sustainability:** Shell and liner are made of a soft, lightweight, durable and 100% recycled nylon. .
- **Packable Comfort:** 900-fill down provides excellent loft and compression; bag fit is designed for ideal blend of comfort, heat retention and packability. .
- **Zoned Insulation:** Updated baffle design maximizes warmth and trims weight by concentrating down where you need it most .
- **Toe-asis™ Foot Warmer Pocket:** Rapidly heat cold feet with a baffled, ergonomic and insulated pocket in the footbox that helps concentrate warmth. .
- **More Features You'll Love:** Internal stash pocket for small items; cinchable hood to retain warmth; YKK anti-snag zipper prevents accidental tears and eases entry and exit. .
- Compression and storage sack included.

SIZE	Regular	Long
SKU	14386	14387
DIMENSIONS	79 x 203 x 13 cm (31 x 80 x 5 in)	83 x 216 x 13 cm (32.5 x 85 x 5 in)
WEIGHT	820 g (29 oz)	886 g (31 oz)
FILL	900-Fill PFAS-Free Hydrophobic Duck Down, RDS	
FILL WEIGHT	490 g (17 oz)	545 g (19 oz)
RECOMMENDED TEMPERATURE	EN COMFORT: 29 °F / -1 °C EN LIMIT: 18 °F / -8 °C	
GIRTH (SHOULDER / HIP / FOOT)	157 / 142 / 107 cm (62 / 56 / 42 in)	165 / 147 / 122 cm (65 / 58 / 48 in)
FABRIC	100% Recycled 20D Nylon Ripstop, DWR	
PACKED SIZE	18 x 27 cm (7 x 10.5 in)	

UPDATED



Reflecting Pond

## Parsec™ 0F/-18C Sleeping Bag

Updated with premium 900-fill down and a refined baffle structure, this high-performance bag is ideal for backcountry pursuits where you want to travel fast and light.

- **Ultralight Warmth:** More down than ever before provides exceptional warmth. Premium 900-fill hydrophobic down is RDS-certified and PFAS-free.
- **High-Performance Sustainability:** Shell and liner are made of a soft, lightweight, durable and 100% recycled nylon. .
- **Packable Comfort:** 900-fill down provides excellent loft and compression; bag fit is designed for ideal blend of comfort, heat retention and packability. .
- **Zoned Insulation:** Updated baffle design maximizes warmth and trims weight by concentrating down where you need it most .
- **Toe-asis™ Foot Warmer Pocket:** Rapidly heat cold feet with a baffled, ergonomic and insulated pocket in the footbox that helps concentrate warmth. .
- **More Features You'll Love:** Internal stash pocket for small items; cinchable hood to retain warmth; YKK anti-snag zipper prevents accidental tears and eases entry and exit. .
- Compression and storage sack included.

SIZE	Regular	Long
SKU	14384	14385
DIMENSIONS	79 x 203 x 19 cm (31 x 80 x 7.5 in)	83 x 216 x 19 cm (32.5 x 85 x 7.5 in)
WEIGHT	1100 g (39 oz)	1194 g (42 oz)
FILL	900-Fill PFAS-Free Hydrophobic Duck Down, RDS	
FILL WEIGHT	762 g (27 oz)	857 g (30 oz)
RECOMMENDED TEMPERATURE	EN COMFORT: 14 °F / -10 °C EN LIMIT: 0 °F / -18 °C	
GIRTH (SHOULDER / HIP / FOOT)	157 / 145 / 107 cm (62 / 57 / 42 in)	165 / 147 / 122 cm (65 / 58 / 48 in)
FABRIC	100% Recycled 20D Nylon Ripstop, DWR	
PACKED SIZE	19 x 30 cm (7.5 x 11 in)	



Black Forest

## Hyperion™ 32F/0C Sleeping Bag

For objectives that demand a light pack and a good night's sleep, the Hyperion provides peak performance for uncompromising adventurers.

- **Ultralight:** One of the lightest pieces in its class, the Hyperion sets a new standard for high-performance outdoor equipment.
- **900-Fill Nikwax Hydrophobic Down™:** Absorbs 90% less water and dries 3 times faster without using dangerous PFCs.
- **Unrivaled Packability:** Lightweight materials and precise design allow for a smaller packed size than ever before.
- **Box-Baffled Construction:** Uses mesh walls to maximize loft and minimize cold spots.
- **SynergyLink™ Connectors:** Integrate the bag with a mattress for optimal efficiency and comfort; removable for versatility.
- **Zoned Insulation:** Maximizes warmth and saves weight by intentionally placing fill where you need it most.
- **Responsible Down Standard Certified:** Certification that ensures that the waterfowl in the down supply chain are treated humanely.
- **Additional Features:** Heat-trapping draft collar, zipper draft tube and cinchable hood.
- Compression sack and storage sack included.

SIZE	Regular	Long
SKU	10721	10722
DIMENSIONS	72 x 203 x 10 cm (28.5 x 80 x 4 in)	74 x 216 x 10 cm (29 x 85 x 4 in)
WEIGHT	464 g (16 oz)	520 g (18 oz)
FILL	900-Fill Nikwax Hydrophobic Goose Down, RDS	
FILL WEIGHT	245 g (8.5 oz)	285 g (10 oz)
RECOMMENDED TEMPERATURE	EN COMFORT: 41 °F / 5 °C EN LIMIT: 32 °F / 0 °C	
GIRTH (SHOULDER / HIP / FOOT)	145 / 126 / 109 cm (57 / 49.5 / 43 in)	147 / 130 / 117 cm (58 / 51 / 46 in)
FABRIC	10D Nylon Ripstop	
PACKED SIZE	15 x 20 cm (6 x 8 in)	



Deep Pacific

## Hyperion™ 20F/-6C Sleeping Bag

For objectives that demand a light pack and a good night's sleep, the Hyperion provides peak performance for uncompromising adventurers.

- **Ultralight:** One of the lightest pieces in its class, the Hyperion sets a new standard for high-performance outdoor equipment.
- **900-Fill Nikwax Hydrophobic Down™:** Absorbs 90% less water and dries 3 times faster without using dangerous PFCs.
- **Unrivaled Packability:** Lightweight materials and precise design allow for a smaller packed size than ever before.
- **Box-Baffled Construction:** Uses mesh walls to maximize loft and minimize cold spots.
- **SynergyLink™ Connectors:** Integrate the bag with a mattress for optimal efficiency and comfort; removable for versatility.
- **Zoned Insulation:** Maximizes warmth and saves weight by intentionally placing fill where you need it most.
- **Responsible Down Standard Certified:** Certification that ensures that the waterfowl in the down supply chain are treated humanely.
- **Additional Features:** Heat-trapping draft collar, zipper draft tube and cinchable hood.
- Compression sack and storage sack included.

SIZE	Regular	Long
SKU	10723	10724
DIMENSIONS	72 x 203 x 11 cm (28.5 x 80 x 4.5 in)	74 x 216 x 11 cm (29 x 85 x 4.5 in)
WEIGHT	577 g (20 oz)	634 g (22 oz)
FILL	900-Fill Nikwax Hydrophobic Goose Down, RDS	
FILL WEIGHT	360 g (12.5 oz)	400 g (14 oz)
RECOMMENDED TEMPERATURE	EN COMFORT: 32 °F / 0 °C EN LIMIT: 20 °F / -6 °C	
GIRTH (SHOULDER / HIP / FOOT)	145 / 126 / 109 cm (57 / 49.5 / 43 in)	147 / 130 / 117 cm (58 / 51 / 46 in)
FABRIC	10D Nylon Ripstop	
PACKED SIZE	15 x 20 cm (6 x 8 in)	



Balsam

## Ohm™ 20F/-6C Sleeping Bag

Find balance with the Ohm's featherweight construction and roomy semi-rectangular shape.

- **Ultralight & Unique:** Packs down super small but provides supreme comfort with its semi-rectangular profile—the Ohm is one-of-a-kind in the true ultralight class .
- **900-Fill Nikwax Hydrophobic Down™:** Responsible Down Standard certified, it absorbs 90% less water and dries 3 times faster without using dangerous PFCs.
- **High Utility:** Full length zipper allows for use as conventional sleeping bag or fully unzip it for a blanket on warmer nights .
- **Pairable:** Stack two fully unzipped Ohms and pair them for a cozy two-person sleeping bag.
- Compression sack and storage sack included.

SIZE	Regular	Long
SKU	11403	11404
DIMENSIONS	81 x 188 x 11 cm (32 x 73 x 4.5 in)	85 x 201 x 11 cm (33.5 x 79 x 4.5 in)
WEIGHT	635 g (22 oz)	720 g (25 oz)
FILL	900-Fill Nikwax Hydrophobic Goose Down, RDS	
FILL WEIGHT	355 g (12.5 oz)	385 g (13.6 oz)
RECOMMENDED TEMPERATURE	EN COMFORT: 32 °F / 0 °C EN LIMIT: 20 °F / -6 °C	
GIRTH (SHOULDER / HIP / FOOT)	157 / 142 / 89 cm (62 / 56 / 35 in)	168 / 150 / 97 cm (66 / 59 / 38 in)
FABRIC	10D Nylon Ripstop	
PACKED SIZE	17 x 20 cm (6.5 x 8 in)	



Ether

## Vesper™ 32F/0C Quilt

High-performance warmth meets ultralight packability.

- **Warm & Lightweight:** 900-fill RDS-certified hydrophobic down keeps it light, compact and warm.
- **Unrivaled Packability:** Lightweight materials and precise design pack into a minimalist compression sack.
- **Box-Baffled Construction:** Uses mesh walls to maximize loft and minimize cold spots.
- **SynergyLink™ Connector:** Integrate the quilt with a mattress for optimal efficiency and comfort; removable for versatility.
- **Draft Protected:** Perimeter side baffles and draw-cord neck closure eliminate unwanted drafts.
- **Responsible Down Standard Certified:** Certification that ensures that the waterfowl in the down supply chain are treated humanely.
- Compression sack and storage sack included.

SIZE	Regular	Long
SKU	14347	14348
DIMENSIONS	147 x 191 x 11.4 cm (58 x 75 x 4 in)	155 x 201 x 11.4 cm (61 x 79 x 4 in)
WEIGHT	440 g (15 oz)	490 g (17 oz)
FILL	900-Fill PFAS-Free Hydrophobic Goose Down, RDS	
FILL WEIGHT	240 g (8.5 oz)	270 g (9.5 oz)
RECOMMENDED TEMPERATURE	EN COMFORT: 41 °F / 5 °C EN LIMIT: 32 °F / 0 °C	
GIRTH (SHOULDER / HIP / FOOT)	125 / 109 / 103 cm (49 / 43 / 40.5 in)	132 / 117 / 111 cm (52 / 46 / 43.5 in)
FABRIC	10D Nylon Ripstop	
PACKED SIZE	13 x 15 cm (5 x 6 in)	



Vapor

## Vesper™ 20F/-6C Quilt

High-performance warmth meets ultralight packability.

- **Warm & Lightweight:** 900-fill RDS-certified hydrophobic down keeps it light, compact and warm.
- **Unrivaled Packability:** Lightweight materials and precise design pack into a minimalist compression sack.
- **Box-Baffled Construction:** Uses mesh walls to maximize loft and minimize cold spots.
- **SynergyLink™ Connector:** Integrate the quilt with a mattress for optimal efficiency and comfort; removable for versatility.
- **Draft Protected:** Perimeter side baffles and draw-cord neck closure eliminate unwanted drafts.
- **Responsible Down Standard Certified:** Certification that ensures that the waterfowl in the down supply chain are treated humanely.
- Compression sack and storage sack included.

SIZE	Regular	Long
SKU	14345	14346
DIMENSIONS	147 x 191 x 10.1 cm (58 x 75 x 4.5 in)	155 x 201 x 10.1 cm (61 x 79 x 4.5 in)
WEIGHT	550 g (19 oz)	610 g (21 oz)
FILL	900-Fill PFAS-Free Hydrophobic Goose Down, RDS	
FILL WEIGHT	360 g (12.5 oz)	390 g (13.5 oz)
RECOMMENDED TEMPERATURE	EN COMFORT: 32 °F / 0 °C EN LIMIT: 20 °F / -6 °C	
GIRTH (SHOULDER / HIP / FOOT)	125 / 109 / 103 cm (49 / 43 / 40.5 in)	132 / 117 / 111 cm (52 / 46 / 43.5 in)
FABRIC	10D Nylon Ripstop	
PACKED SIZE	14 x 20 cm (5.5 x 8 in)	



Meadow Green



## Boost 650™ 32F/0C Sleeping Bag

Spacious, semi-rectangular bag when you want it, toasty mummy bag when you need it—the lightweight and packable Boost 650 empowers you to truly be comfortable in the backcountry.

- **WarmZip™ Tech:** Patent-pending center zipper design reduces the bag's internal space and tucks insulation around the sleeper to boost warmth by up to 10F/6C.
- **Power to the Sleeper:** Enjoy the spacious freedom of the semi-rectangular bag or the cozy warmth of a mummy bag—pick the shape and temperature that keeps you comfy at night with just a zip.
- **Multi-use Arm Holes:** Reach the WarmZip, read a book, play cards or simply ventilate—do it all while tucked into your sleeping bag.
- **Puffed Up & Zoned Out:** Ample 650-fill RDS-certified hydrophobic down is allocated to key areas with Zoned Insulation to maximize heat retention and minimize overall weight.
- **Eco-conscious Product:** Shell and liner are made of GRS-certified 100% recycled, soft-to-the-touch nylon and coated with PFAS-free DWR.
- **Inclusive Sizing:** Each size—Short, Regular, Long—is also available in a Wide size, so you get the bag you want in the fit you need.
- **Additional Features:** YKK anti-snag zippers, cinchable hood, zipper draft tube, puffed draft collar and a two-way entry zipper.
- Compression sack and storage sack included.

SIZE	Regular	Regular Wide	Long
SKU	14197	14198	14199
DIMENSIONS	81 x 203 x 10 cm (32 x 80 x 4 in)	97 x 203 x 10 cm (38 x 80 x 4 in)	83 x 216 x 10 cm (32.5 x 85 x 4 in)
WEIGHT	950 g (34 oz)	1120 g (40 oz)	1110 g (39 oz)
FILL	650-Fill PFAS-Free Hydrophobic Duck Down, RDS		
FILL WEIGHT	401 g (14 oz)	537 g (19 oz)	451 g (16 oz)
RECOMMENDED TEMPERATURE	EN COMFORT: 41 °F / 5 °C EN LIMIT: 32 °F / 0 °C		
GIRTH (SHOULDER / HIP / FOOT)	163 / 152 / 155 cm (64 / 60 / 61 in)	193 / 188 / 155 cm (76 / 74 / 61 in)	165 / 155 / 155 cm (65 / 61 / 61 in)
FABRIC	20D Recycled Nylon Ripstop		
PACKED SIZE	17 x 25 cm (6.5 x 10 in)	17 x 28 cm (6.5 x 11 in)	17 x 28 cm (6.5 x 11 in)



Morning Blue

## Boost 650™ 20F/-6C Sleeping Bag

Spacious, semi-rectangular bag when you want it, toasty mummy bag when you need it—the lightweight and packable Boost 650 empowers you to truly be comfortable in the backcountry.

- **WarmZip™ Tech:** Patent-pending center zipper design reduces the bag’s internal space and tucks insulation around the sleeper to boost warmth by up to 10F/6C.
- **Power to the Sleeper:** Enjoy the spacious freedom of the semi-rectangular bag or the cozy warmth of a mummy bag—pick the shape and temperature that keeps you comfy at night with just a zip.
- **Multi-use Arm Holes:** Reach the WarmZip, read a book, play cards or simply ventilate—do it all while tucked into your sleeping bag.
- **Puffed Up & Zoned Out:** Ample 650-fill RDS-certified hydrophobic down is allocated to key areas with Zoned Insulation to maximize heat retention and minimize overall weight.
- **Eco-conscious Product:** Shell and liner are made of GRS-certified 100% recycled, soft-to-the-touch nylon and coated with PFAS-free DWR.
- **Inclusive Sizing:** Each size—Short, Regular, Long—is also available in a Wide size, so you get the bag you want in the fit you need.
- **Additional Features:** YKK anti-snag zippers, cinchable hood, zipper draft tube, puffed draft collar and a two-way entry zipper.
- Compression sack and storage sack included.

SIZE	Regular	Regular Wide	Long
SKU	14203	14204	14205
DIMENSIONS	81 x 203 x 11 cm (32 x 80 x 4.5 in)	97 x 203 x 11 cm (38 x 80 x 4.5 in)	83 x 216 x 11 cm (32.5 x 85 x 4.5 in)
WEIGHT	1210 g (43 oz)	1520 g (53 oz)	1400 g (49 oz)
FILL	650-Fill PFAS-Free Hydrophobic Duck Down, RDS		
FILL WEIGHT	649 g (23 oz)	909 g (32 oz)	733 g (26 oz)
RECOMMENDED TEMPERATURE	EN COMFORT: 32 °F / 0 °C EN LIMIT: 20 °F / -6 °C		
GIRTH (SHOULDER / HIP / FOOT)	163 / 152 / 155 cm (64 / 60 / 61 in)	193 / 188 / 155 cm (76 / 74 / 61 in)	165 / 155 / 155 cm (65 / 61 / 61 in)
FABRIC	20D Recycled Nylon Ripstop		
PACKED SIZE	19 x 32 cm (7.5 x 12.5 in)	19 x 34 cm (7.5 x 13.5 in)	19 x 33 cm (7.5 x 13 in)



Balsam

## Questar™ 32F/0C Sleeping Bag

For the comfort-conscious backpacker, the Questar blends comfort features with a backcountry-friendly packed size.

- **650-Fill Nikwax Hydrophobic Down™:** Absorbs 90% less water and dries 3 times faster without using dangerous PFCs for better performance in wet weather.
- **SynergyLink™ Connectors:** Integrate the bag with a mattress for optimal comfort and thermal efficiency; removable for versatility.
- **Zoned Insulation:** Maximizes warmth and saves weight by intentionally placing down where you need it most.
- **Box Baffled Construction:** Uses mesh walls to maximize loft and minimize cold spots.
- **Toe-asis™ Foot Warmer Pocket:** Baffled pocket of insulation rapidly warms cold feet.
- **Quilt and Blanket Loops:** Customize your sleep system by layering our quilts or tech blankets for increased warmth.
- **Responsible Down Standard Certified:** Certification that ensures that the waterfowl in the down supply chain are treated humanely.
- **Additional Features:** Heat-trapping draft collar, full-length zipper draft tube, snag-free zipper, cinchable hood and external zip pocket.
- Compression sack and storage sack included.

SIZE	Regular	Long
SKU	13153	13154
DIMENSIONS	80 x 203 x 10 cm (31.5 x 80 x 4 in)	84 x 216 x 10 cm (33 x 85 x 4 in)
WEIGHT	849 g (30 oz)	881 g (31 oz)
FILL	650-Fill Nikwax Hydrophobic Duck Down, RDS	
FILL WEIGHT	400 g (14 oz)	435 g (15 oz)
RECOMMENDED TEMPERATURE	EN COMFORT: 41 °F / 5 °C EN LIMIT: 32 °F / 0 °C	
GIRTH (SHOULDER / HIP / FOOT)	160 / 155 / 117 cm (63 / 61 / 46 in)	168 / 163 / 130 cm (66 / 64 / 51 in)
FABRIC	20D Polyester Ripstop	
PACKED SIZE	17 x 22 cm (6.5 x 8.5 in)	



Balsam

## Questar™ 20F/-6C Sleeping Bag

For the comfort-conscious backpacker, the Questar blends comfort features with a backcountry-friendly packed size.

- **650-Fill Nikwax Hydrophobic Down™:** Absorbs 90% less water and dries 3 times faster without using dangerous PFCs for better performance in wet weather.
- **SynergyLink™ Connectors:** Integrate the bag with a mattress for optimal comfort and thermal efficiency; removable for versatility.
- **Zoned Insulation:** Maximizes warmth and saves weight by intentionally placing down where you need it most.
- **Box Baffled Construction:** Uses mesh walls to maximize loft and minimize cold spots.
- **Toe-asis™ Foot Warmer Pocket:** Baffled pocket of insulation rapidly warms cold feet.
- **Quilt and Blanket Loops:** Customize your sleep system by layering our quilts or tech blankets for increased warmth.
- **Responsible Down Standard Certified:** Certification that ensures that the waterfowl in the down supply chain are treated humanely.
- **Additional Features:** Heat-trapping draft collar, full-length zipper draft tube, snag-free zipper, cinchable hood and external zip pocket.
- Compression sack and storage sack included.

SIZE	Regular	Long
SKU	13156	13157
DIMENSIONS	80 x 203 x 11 cm (31.5 x 80 x 4.5 in)	84 x 216 x 11 cm (33 x 85 x 4.5 in)
WEIGHT	991 g (35 oz)	1117 g (39 oz)
FILL	650-Fill Nikwax Hydrophobic Duck Down, RDS	
FILL WEIGHT	540 g (19 oz)	610 g (22 oz)
RECOMMENDED TEMPERATURE	EN COMFORT: 32 °F / 0 °C EN LIMIT: 20 °F / -6 °C	
GIRTH (SHOULDER / HIP / FOOT)	160 / 155 / 117 cm (63 / 61 / 46 in)	168 / 163 / 130 cm (66 / 64 / 51 in)
FABRIC	20D Polyester Ripstop	
PACKED SIZE	19 x 23 cm (7.5 x 9 in)	



Balsam

## Questar™ 0F/-18C Sleeping Bag

For the comfort-conscious backpacker, the Questar blends comfort features with a backcountry-friendly packed size.

- **SynergyLink™ Connectors:** Integrate the bag with a mattress for optimal comfort and thermal efficiency; removable for versatility
- **Zoned Insulation:** Maximizes warmth and saves weight by intentionally placing down where you need it most
- **Box Baffled Construction:** Uses mesh walls to maximize loft and minimize cold spots
- **Toe-asis™ Foot Warmer Pocket:** Baffled pocket of insulation rapidly warms cold feet
- **Quilt and Blanket Loops:** Customize your sleep system by layering our quilts or tech blankets for increased warmth
- **Responsible Down Standard Certified:** Certification that ensures that the waterfowl in the down supply chain are treated humanely
- **Additional Features:** Heat-trapping draft collar, full-length zipper draft tube, snag-free zipper, cinchable hood and external zip pocket
- Compression sack and storage sack included

SIZE	Regular	Long
SKU	13159	13160
DIMENSIONS	80 x 203 x 14 cm (31.5 x 80 x 5.5 in)	84 x 216 x 14 cm (33 x 85 x 5.5 in)
WEIGHT	1210 g (43 oz)	1381 g (49 oz)
FILL	650-Fill Nikwax Hydrophobic Duck Down, RDS	
FILL WEIGHT	820 g (29 oz)	890 g (31 oz)
RECOMMENDED TEMPERATURE	EN COMFORT: 14 °F / -10 °C EN LIMIT: 0 °F / -18 °C	
GIRTH (SHOULDER / HIP / FOOT)	160 / 155 / 117 cm (63 / 61 / 46 in)	168 / 163 / 130 cm (66 / 64 / 51 in)
FABRIC	20D Polyester Ripstop	
PACKED SIZE	20 x 25 cm (8 x 10 in)	

UPDATED



Twill

## Corus™ 32F/0C Quilt

Save weight and venture deep into the backcountry with this high-performance backpacking quilt.

- **Warm & Lightweight:** 650-fill RDS-certified hydrophobic down keeps it light, compact and warm.
- **Compact:** Designed to easily fit into your pack.
- **Box-Baffled Construction:** Uses mesh walls to maximize down loft and minimize cold spots.
- **SynergyLink™ Connectors:** Integrate the quilt with a mattress for optimal efficiency and comfort; removable for versatility.
- **Thoughtful Footbox:** Precisely shaped footbox can slip over your pad to eliminate drafts or over your feet for extra warmth.
- **Draft Protection:** Full-perimeter side baffles and snap neck closure keep out unwanted drafts.
- **Build a System:** Pair with another Therm-a-Rest quilt, sleeping bag, blanket or sheet to build a layered system.
- Stuff sack and storage sack included.

SIZE	Regular	Long
SKU	14207	14208
DIMENSIONS	128 x 201 x 10.1 cm (49.5 x 79 x 4 in)	135 x 211 x 10.1 cm (53 x 83 x 4 in)
WEIGHT	560 g (20 oz)	620 g (22 oz)
FILL	650-Fill PFAS-Free Hydrophobic Duck Down, RDS	
FILL WEIGHT	340 g (12 oz)	370 g (13 oz)
RECOMMENDED TEMPERATURE	EN COMFORT: 41 °F / 5 °C EN LIMIT: 32 °F / 0 °C	
GIRTH (SHOULDER / HIP / FOOT)	125 / 121 / 130 cm (49 / 51.5 / 51 in)	135 / 131 / 160 cm (53 / 51.5 / 63 in)
FABRIC	100% Recycled 20D Nylon Ripstop, DWR	
PACKED SIZE	17 x 25 cm (6.5 x 10 in)	



Hedge Green

## Corus™ 20F/-6C Quilt

Save weight and venture deep into the backcountry with this high-performance backpacking quilt.

- **Warm & Lightweight:** 650-fill RDS-certified hydrophobic down keeps it light, compact and warm.
- **Compact:** Designed to easily fit into your pack.
- **Box-Baffled Construction:** Uses mesh walls to maximize down loft and minimize cold spots.
- **SynergyLink™ Connectors:** Integrate the quilt with a mattress for optimal efficiency and comfort; removable for versatility.
- **Thoughtful Footbox:** Precisely shaped footbox can slip over your pad to eliminate drafts or over your feet for extra warmth.
- **Draft Protection:** Full-perimeter side baffles and snap neck closure keep out unwanted drafts.
- **Build a System:** Pair with another Therm-a-Rest quilt, sleeping bag, blanket or sheet to build a layered system.
- Stuff sack and storage sack included.

SIZE	Regular	Long
SKU	14210	14211
DIMENSIONS	128 x 201 x 11.4 cm (49.5 x 79 x 4.5 in)	135 x 211 x 11.4 cm (53 x 83 x 4.5 in)
WEIGHT	735 g (26 oz)	815 g (29 oz)
FILL	650-Fill PFAS-Free Hydrophobic Duck Down, RDS	
FILL WEIGHT	530 g (19 oz)	560 g (20 oz)
RECOMMENDED TEMPERATURE	EN COMFORT: 32 °F / 0 °C EN LIMIT: 20 °F / -6 °C	
GIRTH (SHOULDER / HIP / FOOT)	125 / 121 / 130 cm (49 / 47.5 / 51 in)	135 / 131 / 160 cm (53 / 51.5 / 63 in)
FABRIC	100% Recycled 20D Nylon Ripstop, DWR	
PACKED SIZE	19 x 29 cm (7.5 x 11.5 in)	



Storm

## Vela™ Double 32F/0C Quilt

The perfect sleep solution for backpacking pairs seeking a high performance and lightweight tandem quilt.

- **650-Fill Nikwax Hydrophobic Down™:** Absorbs 90% less water and dries 3x faster without using dangerous PFCs for better performance in wet weather.
- **Box Baffled Construction:** Uses mesh walls to maximize down loft and minimize cold spots.
- **Draft Protection:** Full-perimeter side baffles keep out unwanted drafts.
- **Thoughtful Footbox:** Precisely shaped footbox can slip over your pad to eliminate drafts or over your feet for extra warmth.
- **Build a System:** Pair with another Therm-a-Rest quilt, sleeping bag, blanket or sheet to build a layered system.
- Stuff sack and storage sack included.

<b>SIZE</b>	<b>Double</b>
<b>SKU</b>	13174
<b>DIMENSIONS</b>	208 x 203 x 10 cm (82 x 80 x 4 in)
<b>WEIGHT</b>	987 g (35 oz)
<b>FILL</b>	650-Fill Nikwax Hydrophobic Duck Down, RDS
<b>FILL WEIGHT</b>	514 g (18 oz)
<b>RECOMMENDED TEMPERATURE</b>	EN COMFORT: 41 °F / 5 °C EN LIMIT: 32 °F / 0 °C
<b>GIRTH (SHOULDER / HIP / FOOT)</b>	208 / 208 / 254 cm (82 / 82 / 100 in)
<b>FABRIC</b>	20D Polyester
<b>PACKED SIZE</b>	20 x 33 cm (8 x 13 in)



Storm

## Vela™ Double 20F/-6C Quilt

The perfect sleep solution for backpacking pairs seeking a high performance and lightweight tandem quilt.

- **650-Fill Nikwax Hydrophobic Down™:** Absorbs 90% less water and dries 3x faster without using dangerous PFCs for better performance in wet weather.
- **Box Baffled Construction:** Uses mesh walls to maximize down loft and minimize cold spots.
- **Draft Protection:** Full-perimeter side baffles keep out unwanted drafts.
- **Thoughtful Footbox:** Precisely shaped footbox can slip over your pad to eliminate drafts or over your feet for extra warmth.
- **Build a System:** Pair with another Therm-a-Rest quilt, sleeping bag, blanket or sheet to build a layered system.
- Stuff sack and storage sack included.

<b>SIZE</b>	<b>Double</b>
<b>SKU</b>	13175
<b>DIMENSIONS</b>	208 x 203 x 11 cm (82 x 80 x 4.5 in)
<b>WEIGHT</b>	1268 g (45 oz)
<b>FILL</b>	650-Fill Nikwax Hydrophobic Duck Down, RDS
<b>FILL WEIGHT</b>	890 g (31 oz)
<b>RECOMMENDED TEMPERATURE</b>	EN COMFORT: 32 °F / 0 °C EN LIMIT: 20 °F / -6 °C
<b>GIRTH (SHOULDER / HIP / FOOT)</b>	208 / 208 / 254 cm (82 / 82 / 100 in)
<b>FABRIC</b>	20D Polyester
<b>PACKED SIZE</b>	23 x 41 cm (9 x 16 in)



Burgundy



Animal Print



Dark Olive



Outer Space Blue



Stripe Print



Space Print

## Honcho Poncho™ Down

Be iconic, be multi-functional, and elevate performance with hydrophobic down to achieve the ultimate camp comfort with the Honcho Poncho Down.

- **Premium Down Insulation:** RDS-certified 650-fill hydrophobic down delivers superior wet-weather performance to keep you cozy in all conditions.
- **Refined Fit:** Snap layout and articulated shape maximizes the benefits of a poncho while cutting back on annoying excess fabric that gets in the way when performing tasks like cooking.
- **Compact Packing:** Front pocket doubles as built-in stuff sack for easy and compact on-the-go storage.
- **Thoughtful Features:** Half-length zipper, three-panel fitted hood, quilted pattern, and hanger loop make wearing the Honcho Poncho Down an experience of comfort, functionality, performance and fun.
- **Improved Fabrics:** DWR-coated recycled polyester is water resistant, sustainable and more comfortable without sacrificing durability.

SIZE	One Size
SKU	11603, 11604, 11605
DIMENSIONS	123 x 106 x 5 cm (48 x 42 x 2 in)
WEIGHT	529 g (19 oz)
FILL	650-Fill Nikwax Hydrophobic Duck Down, RDS
FILL WEIGHT	265 g (9.3 oz)
FABRIC	100% Recycled 20D Nylon w/ DWR
PACKED SIZE	32 x 24 cm (13 x 9 in)

## Honcho Poncho™ Kids

In response to popular demand and due to its general awesomeness, the Honcho Poncho now comes in a kids' version.

- **Warm & Light Insulation:** Efficient and compressible, our water-resistant synthetic fill uses hollow fibers to reduce weight without sacrificing warmth.
- **Weather-Ready:** DWR-coated water-resistant shell and hood are perfect for puddle jumping.
- **Cozy:** Perfect any time your kiddo needs a little extra warmth (and a great solution for little ones who never seem to want to wear a jacket).
- **Handy:** Kangaroo pocket keeps little hands warm and top zip pocket stows essentials.
- **Shape-Shifting:** Snaps under the arms transform the poncho into a blanket and back again.
- **Packable:** Packs into its own zip storage pocket.
- **One Size:** Fits most 6- to 12-year-olds.

SIZE	One Size
SKU	13854, 13855, 13856
DIMENSIONS	74 x 142 x 2.5 cm (29 x 56 x 1 in)
WEIGHT	370 g (11.5 oz)
FILL	eraLoft™ Recycled Polyester Hollow Fiber
FILL WEIGHT	128 g (4.5 oz)
FABRIC	20D Polyester Ripstop/50D Polyester
PACKED SIZE	22 x 27 cm (8.5 x 10.5 in)



Blue Woven Print



Wheat



Mars Red



New Blue

## Honcho Poncho™

The ever-popular insulated adventure poncho that doubles as a stylish and cozy blanket.

- **Warm & Light Insulation:** Efficient and compressible, our water-resistant synthetic fill uses hollow fibers to reduce weight without sacrificing warmth.
- **Water Resistant:** Offers a wet-weather barrier with its water-resistant and breathable shell.
- **Versatile:** Use at camp, at the game or anywhere you want a little warmth and freedom.
- **Handy:** Kangaroo pocket warms hands and top zip pocket stows essentials.
- **Packable:** Packs into its own storage pocket.

<b>SIZE</b>	<b>One Size</b>
<b>SKU</b>	11417, 11418, 11419, 13176
<b>DIMENSIONS</b>	142 x 201 x 2.5 cm (56 x 79 x 1 in)
<b>WEIGHT</b>	690 g (24 oz)
<b>FILL</b>	eraLoft Polyester Hollow Fiber
<b>FILL WEIGHT</b>	270 g (9.5 oz)
<b>FABRIC</b>	20D Polyester Ripstop Shell, 50D Polyester Lining
<b>PACKED SIZE</b>	28 x 43 cm (11 x 17 in)



Outerspace Blue



Greenwave



Tomato



Valley View Print



Peeking Pine Print



Space Case Print

## Argo™ Blanket

Pack luxury wherever you go with our ultra-soft and roomy blanket for two.

- **eraLoft™ Insulation:** Efficient and compressible, our water-resistant synthetic fill uses hollow fibers to reduce weight without ignoring warmth.
- **Next-to-Skin Comfort:** Soft-touch polyester lining.
- **Draft Protection:** Drawcord at bottom edge reduces drafts and cinches around feet to keep the blanket in place.
- **Versatile:** Perimeter snap loops mate with another Therm-a-Rest quilt, blanket or sheet.
- **Packable:** Compresses into built-in pocket, which can easily double as a camp pillow.
- **Tasteful Design:** Express yourself and your love of the outdoors with the Argo's offering of tasteful colors, patterns, prints and hand-drawn illustrations.

SIZE	One Size
SKU	11427, 10709, 11546
DIMENSIONS	183 x 198 x 2.5 cm (72 x 78 x 1 in)
WEIGHT	723 g (26 oz)
FILL	eraLoft Polyester Hollow Fiber
FILL WEIGHT	295 g (10.5 oz)
FABRIC	30D Polyester
PACKED SIZE	36 x 43 cm (14 x 17 in)

## Stellar™ Blanket

The definition of camp utility blanket, the one-person Stellar Blanket is equally at home in the backyard as it is in backcountry.

















- **eraLoft™ Insulation:** Efficient and compressible, our water-resistant synthetic fill uses hollow fibers to reduce weight without sacrificing warmth.
- **Next-to-Skin Comfort:** Soft-touch polyester lining.
- **Draft Protection:** Drawcord at bottom edge reduces drafts and cinches around feet to keep the blanket in place.
- **Versatile:** Perimeter snap loops mate with another Therm-a-Rest quilt, blanket or sheet.
- **Packable:** Compresses into built-in pocket, which can easily double as a camp pillow.
- **Tasteful Design:** Express yourself and your love of the outdoors with the Stellar's offering of tasteful colors, patterns, prints and hand-drawn illustrations.

SIZE	One Size
SKU	11426, 11545, 11425
DIMENSIONS	142 x 191 x 2.5 cm (56 x 75 x 1 in)
WEIGHT	612 g (22 oz)
FILL	eraLoft Polyester Hollow Fiber
FILL WEIGHT	220 g (8 oz)
FABRIC	30D Polyester
PACKED SIZE	28 x 36 cm (11 x 14 in)

**THERM-A-REST SLEEPING BAGS, QUILTS & BLANKETS SPECIFICATIONS**

SLEEPING BAGS	SIZE	SKU	FITS	WEIGHT	GIRTH SHOULDER / HIP / FOOT	FABRICS (SHELL/LINING)	FILL	FILL WEIGHT	STUFFED SIZE	RECOMMENDED TEMPERATURE	
Polar Ranger™ -20F/-30C	REGULAR	14212	183 cm (6 ft)	1477 g (3 lb 4 oz)	163/150/117 cm (64/59/46 in)	100% Recycled 20D Nylon Ripstop, DWR	800-Fill PFAS-Free Hydrophobic Duck Down, RDS	965 g (2 lb 2 oz)	22 x 25 cm (8.5 x 10 in)	EN/ISO COMFORT: -4°F / -20°C LIMIT: -20°F / -30°C	
	LONG	14213	198 cm (6 ft 6 in)	1559 g (3 lb 7 oz)	173/152/130 (68/60/51 in)			1070 g (2 lb 5.7 oz)			
Parsec™ 20F/-6C	REGULAR	14386	183 cm (6 ft)	820 g (1 lb 13 oz)	157/142/107 cm (62/56/42 in)	100% Recycled 20D Nylon Ripstop, DWR	900-Fill PFAS-Free Hydrophobic Duck Down, RDS	490 g (1 lb 1 oz)	18 x 27 cm (7 x 10.5 in)	EN/ISO COMFORT: 32°F / 0°C LIMIT: 20°F / -6°C	
	LONG	14387	198 cm (6 ft 6 in)	886 g (1 lb 15 oz)	165/147/122 cm (65/58/48 in)			545 g (1 lb 3 oz)			
Parsec™ 0F/-18C	REGULAR	14384	183 cm (6 ft)	1100 g (2 lb 7 oz)	165/145/102 cm (65/57/40 in)	100% Recycled 20D Nylon Ripstop, DWR	900-Fill PFAS-Free Hydrophobic Duck Down, RDS	762 g (1 lb 11 oz)	19 x 28 cm (7.5 x 11 in)	EN/ISO COMFORT: 14°F / -10°C LIMIT: 0°F / -18°C	
	LONG	14385	198 cm (6 ft 6 in)	1194 g (2 lb 10 oz)	165/147/122 cm (65/58/48 in)			857 g (1 lb 14 oz)			
Ohm™ 20F/-6C	REGULAR	11403	183 cm (6 ft)	635 g (1 lb 6 oz)	157/142/89 cm (62/56/35 in)	10D Nylon RipStop w/DWR / 10D Nylon Ripstop	900-Fill Goose Nikwax® Hydrophobic Down, RDS	355 g (12.5 oz)	17 x 20 cm (6.5 x 8 in)	EN/ISO COMFORT: 32°F / 0°C LIMIT: 20°F / -6°C	
	LONG	11404	198 cm (6 ft 6 in)	720 g (1 lb 9 oz)	168/150/97 cm (66/59/38 in)			387 g (13.7 oz)			
Hyperion™ 32F/0C	REGULAR	10721	183 cm (6 ft)	464 g (1 lb)	145/126/109 cm (57/49.5/43 in)	10D Nylon RipStop w/DWR / 10D Nylon Ripstop	900-Fill Goose Nikwax® Hydrophobic Down, RDS	245 g (8.5 oz)	15 x 20 cm (6 x 8 in)	EN/ISO COMFORT: 32°F / 0°C LIMIT: 20°F / -6°C	
	LONG	10722	198 cm (6 ft 6 in)	520 g (1 lb 2 oz)	147/130/117 cm (58/51/46 in)			285 g (10 oz)			
Hyperion™ 20F/-6C	REGULAR	10723	183 cm (6 ft)	577 g (1 lb 4 oz)	145/126/109 cm (57/49.5/43 in)	10D Nylon RipStop w/DWR / 10D Nylon Ripstop	900-Fill Goose Nikwax® Hydrophobic Down, RDS	360 g (12.5 oz)	15 x 20 cm (6 x 8 in)	EN/ISO COMFORT: 32°F / 0°C LIMIT: 20°F / -6°C	
	LONG	10724	198 cm (6 ft 6 in)	634 g (1 lb 6 oz)	147/130/117 cm (58/51/46 in)			400 g (14 oz)			
Boost 650™ 32F/0C	REGULAR	14197	183 cm (6 ft)	952 g (2 lb 2 oz)	163/152/155 cm (64/60/61 in)	100% Recycled 20D Nylon Ripstop, DWR	650-Fill PFAS-Free Hydrophobic Duck Down, RDS	401 g (14 oz)	25 x 17 cm (10 x 6.5 in)	EN/ISO COMFORT: 41°F / 5°C LIMIT: 32°F / 0°C	
	REGULAR WIDE	14198	183 cm (6 ft)	1121 g (2 lb 8 oz)	193/188/155 cm (76/74/61 in)			537 g (1 lb 3 oz)			28 x 17 cm (11 x 6.5 in)
	LONG	14199	198 cm (6 ft 6 in)	1099 g (2 lb 7 oz)	165/155/155 cm (65/61/61 in)			451 g (1 lb)			33 x 17 cm (13 x 6.5 in)
Boost 650™ 20F/-6C	REGULAR	14203	183 cm (6 ft)	1205 g (2 lb 11 oz)	163/152/155 cm (64/60/61 in)	100% Recycled 20D Nylon Ripstop, DWR	650-Fill PFAS-Free Hydrophobic Duck Down, RDS	649 g (1 lb 7 oz)	32 x 19 cm (12.5 x 7.5 in)	EN/ISO COMFORT: 32°F / 0°C LIMIT: 20°F / -6°C	
	REGULAR WIDE	14204	183 cm (6 ft)	1515 g (3 lb 5 oz)	193/188/155 cm (76/74/61 in)			909 g (2 lb)			34 x 19 cm (13.5 x 7.5 in)
	LONG	14205	198 cm (6 ft 6 in)	1398 g (3 lb 1 oz)	165/155/155 cm (65/61/61 in)			733 g (1 lb 10 oz)			33 x 19 cm (13 x 8.5 in)
Questar™ 32F/0C	REGULAR	13153	183 cm (6 ft)	849 g (1 lb 14 oz)	160/155/117 cm (63/61/46 in)	20D Polyester RipStop w/ DWR / 20D Polyester Taffeta	650 Fill Duck Nikwax® Hydrophobic Down, RDS	400 g (14 oz)	17 x 22 cm (6.5 in x 8.5 in)	EN/ISO COMFORT: 41°F / 5°C LIMIT: 32°F / 0°C	
	LONG	13154	198 cm (6 ft 6 in)	881 g (1 lb 15 oz)	168/163/130 cm (66/64/51 in)			435 g (15 oz)			
Questar™ 20F/-6C	SMALL	13155	168 cm (5 ft 6 in)	837 g (1 lb 14 oz)	147/147/112 cm (58/58/44 in)	20D Polyester Ripstop w/ DWR, 20D Polyester Taffeta	650-Fill Duck Nikwax® Hydrophobic Down, RDS	470 g (1 lb 1 oz)	19 x 23 cm (7.5 in x 9 in)	EN/ISO COMFORT: 32°F / 0°C LIMIT: 20°F / -6°C	
	REGULAR	13156	183 cm (6 ft)	991 g (2 lb 3 oz)	160/155/117 cm (63/61/46 in)			540 g (1 lb 3 oz)			
	LONG	13157	198 cm (6 ft 6 in)	1117 g (2 lb 7 oz)	168/163/130 cm (66/64/51 in)			610 g (1 lb 6 oz)			
Questar™ 0F/-18C	REGULAR	13159	183 cm (6 ft)	1210 g (2 lb 11 oz)	160/155/117 cm (63/61/46 in)	20D Polyester Ripstop w/ DWR, 20D Polyester Taffeta	650-Fill Duck Nikwax® Hydrophobic Down, RDS	820 g (1 lb 13 oz)	20 x 25 cm (8 in x 10 in)	EN/ISO COMFORT: 14°F / -10°C LIMIT: 0°F / -18°C	
	LONG	13160	198 cm (6 ft 6 in)	1381 g (3 lb 1 oz)	168/163/130 cm (66/64/51 in)			890 g (1 lb 15 oz)			
QUILTS	SIZE	SKU	FITS	WEIGHT	GIRTH SHOULDER / HIP / FOOT	FABRICS (SHELL/LINING)	FILL	FILL WEIGHT	STUFFED SIZE	RECOMMENDED TEMPERATURE	
Vesper™ 32F/0C	REGULAR	14347	183 cm (6 ft)	435 g (15 oz)	147/130/94 cm (58/51/37 in)	10D Nylon Ripstop, DWR	900-Fill PFAS-Free Hydrophobic Goose Down, RDS	235 g (8.5 oz)	13 x 15 cm (5 x 6 in)	COMFORT: 41°F / 5°C LIMIT: 32°F / 0°C	
	LONG	14348	198 cm (6 ft 6 in)	492 g (1 lb 1 oz)	155/137/102 cm (61/54/40 in)			265 g (9.5 oz)			
Vesper™ 20F/-6C	REGULAR	14345	183 cm (6 ft)	549 g (1 lb 3 oz)	147/130/94 cm (58/51/37 in)	10D Nylon Ripstop, DWR	900-Fill PFAS-Free Hydrophobic Goose Down, RDS	355 g (12.5 oz)	14 x 20 cm (5.5 x 8 in)	COMFORT: 32°F / 0°C LIMIT: 20°F / -6°C	
	LONG	14346	198 cm (6 ft 6 in)	605 g (1 lb 5 oz)	155/137/102 cm (61/54/40 in)			385 g (13.5 oz)			
Corus™ Quilt 32F/0C	REGULAR	14207	183 cm (6 ft)	565 g (1 lb 4 oz)	128/121/122 cm (49.5/47.5/48 in)	100% Recycled 20D Nylon Ripstop, DWR	650-Fill PFAS-Free Hydrophobic Duck Down, RDS	339 g (12 oz)	17 x 25 cm (6.5 x 10 in)	COMFORT: 41°F / 5°C LIMIT: 32°F / 0°C	
	LONG	14208	198 cm (6 ft 6 in)	620 g (1 lb 6 oz)	135/131/143 cm (53/51.5/58 in)			370 g (13 oz)			
Corus™ Quilt 20F/-6C	REGULAR	14210	183 cm (6 ft)	735 g (1 lb 10 oz)	128/121/122 cm (49.5/47.5/48 in)	100% Recycled 20D Nylon Ripstop, DWR	650-Fill PFAS-Free Hydrophobic Duck Down, RDS	525 g (1 lb 3 oz)	19 x 29 cm (7.5 x 11.5 in)	COMFORT: 32°F / 0°C LIMIT: 20°F / -6°C	
	LONG	14211	198 cm (6 ft 6 in)	815 g (1 lb 13 oz)	135/131/143 cm (53/51.5/58 in)			560 g (1 lb 4 oz)			
Vela™ Double 32F/0C	DOUBLE	13174	198 cm (6 ft 6 in)	987 g (2 lb 3 oz)	208/208/254 cm (82/82/100 in)	20D Polyester w/ DWR Shell / 20D Polyester Taffeta lining	650-Fill Duck Nikwax® Hydrophobic Down, RDS	514 g (1 lb 2 oz)	20 x 33 cm (8 in x 13 in)	COMFORT: 41°F / 5°C LIMIT: 32°F / 0°C	
Vela™ Double 20F/-6C	DOUBLE	13175	198 cm (6 ft 6 in)	1268 g (2 lb 13 oz)	208/208/254 cm (82/82/100 in)	20D Polyester w/ DWR Shell / 20D Polyester Taffeta lining	650-Fill Duck Nikwax® Hydrophobic Down, RDS	890 g (1 lb 15 oz)	23 x 41 cm (9 x 16 in)	COMFORT: 32°F / 0°C LIMIT: 20°F / -6°C	

## THERM-A-REST SLEEPING BAGS, QUILTS & BLANKETS SPECIFICATIONS

POCHOS	SKU	WEIGHT	DIMENSIONS (L x W)	FABRICS (SHELL/LINING)	FILL	FILL WEIGHT	STUFFED SIZE		
<b>Honcho Poncho™ Down</b>	 11603	 11604	 11605	529 g (1 lb 3 oz)	123 x 106cm (48 x 42 in)	100% Recycled 20D Nylon Ripstop, DWR	650 Fill Duck Nikwax® Hydrophobic Down, RDS	265 g (9.3 oz)	32 x 24 cm (13 x 9 in)
	 11418	 11416	 11622	685 g (1 lb 8 oz)	200 x 142 cm (79 x 56 in)	20D Polyester Ripstop Waterproof Breathable shell / 50D Polyester lining	eraLoft™ Polyester Hollow Fiber	270 g (9.5 oz)	28 x 43 cm (11 x 17 in)
	 11419	 11622							
<b>Honcho Poncho™ Kids</b>	 13854	 13855	 13856	372 g (11.5 oz)	142 x 74 cm (56 x 29 in)	20D Polyester Ripstop DWR, PU Coating / 50D Polyester (no DWR)	eraLoft™ Polyester Hollow Fiber	128 g (4.5 oz)	22 x 27 cm (8.5 x 10.5 in)
BLANKETS	SKU	WEIGHT	DIMENSIONS (L x W)	FABRICS (SHELL/LINING)	FILL	FILL WEIGHT	STUFFED SIZE		
<b>Argo™ Blanket</b>	 11546	 11427	 10709	723 g (1 lb 10 oz)	198 x 183 cm (78 x 72 in)	30D Polyester w/ DWR shell / 30D Polyester lining	eraLoft™ Polyester Hollow Fiber	295 g (10.4 oz)	36 x 43 cm (14 x 17 in)
<b>Stellar™ Blanket</b>	 11545	 11425	 11426	612 g (1 lb 6 oz)	191 x 142 cm (75 x 56 in)	30D Polyester w/ DWR shell / 30D Polyester lining	eraLoft™ Polyester Hollow Fiber	220 g (7.8 oz)	28 x 36 cm (11 x 14 in)



**THERMA-REST® PILLOWS & SEATING**



MUST HAVE

NEW PRINTS



Desert Print



Woodland Print



Outer Space

MUST HAVE



Deep Pacific

## Compressible Pillow Cinch

Customizable firmness on a compact, environmentally friendly pillow is ideal for on-the-go rest.

- **Customize Comfort:** Cinch cord tightens and loosens the cover to adjust firmness to the right level.
- **Ultra-Soft Recycled Fabric:** Rest easy knowing the gentle cover is made from 60% recycled polyester.
- **Upcycled Foam:** Using excess foam from mattress production makes this product both green and comfy.
- **Compressible:** Packs down into itself so you can rest better on-the-go.

SIZE	Small	Regular	Large
SKU	14223, 14222, 14221	14226, 14225, 14224	14229, 14228, 14227
DIMENSIONS	38 x 28 x 11 cm (15 x 11 x 5 in)	46 x 33 x 13 cm (18 x 13 x 6 in)	56 x 38 x 15 cm (22 x 15 x 7 in)
WEIGHT	230 g (8 oz)	325 g (11.5 oz)	450 g (16 oz)
MATERIALS	Urethane foam fill, Polyester Insulation, Polyester Shell		

## Air Head™ Lite Pillow

Ultralight pillow fits in your pocket before inflating to provide big comfort at camp.

- **Essential Comfort:** Four inches of air padding and stretch fabric can be customized to your preferred firmness.
- **Lightweight:** Only weighs a couple ounces and packs down small enough to fit in your pocket.
- **Thoughtful Shape:** Precise shape nestles into the hood of your sleeping bag.

SIZE	Regular	Large
SKU	14001	14002
DIMENSIONS	39 x 28 x 10 cm (15.5 x 11 x 4 in)	46 x 32 x 10 cm (18 x 12.5 x 4 in)
WEIGHT	60 g (2 oz)	80 g (2.8 oz)
MATERIALS	Polyester	



Blue Woven



Yellow Mountains



Midnight Print

## Air Head™ Pillow

**Inflatable core and an ultra-soft topper deliver comfy support after a day on the trail.**

- **Light & Compact:** Packs exceptionally small for easy travel.
- **Thick & Stable:** Four-inch thick, baffled air chamber for stability, loft and custom firmness.
- **Soft:** Synthetic-fill top and a brushed exterior provide next-to-skin comfort. Removable cover is machine washable.
- **Thoughtful Shape:** Precise shape nestles into the hood of your sleeping bag.
- **Sustainable:** Cover fabric includes partially recycled polyester, which supports your head and mother nature.

SIZE	Regular	Large
SKU	14235, 14234	14237, 14236
DIMENSIONS	39 x 28 x 10 cm (15.5 x 11 x 4 in)	46 x 32 x 10 cm (18 x 12.5 x 4 in)
WEIGHT	160 g (5.6 oz)	220 g (7.7 oz)
MATERIALS	Polyester, Urethane	

## Air Head™ Down Pillow

**A supportive and light air pillow with down topper delivers premier comfort for any camp.**

- **Luxurious Down:** Comfy down provides superior comfort. Removable polyester cover is machine washable.
- **Light & Compact:** Packs exceptionally small for easy travel.
- **Thick & Stable:** Four-inch thick, baffled air chamber for stability, loft and custom firmness.
- **Thoughtful Shape:** Precise shape nestles into the hood of your sleeping bag.
- **Sustainable:** Cover fabric includes partially recycled polyester, which supports your head and mother nature.

SIZE	Regular	Large
SKU	14238	14239
DIMENSIONS	39 x 28 x 10 cm (15.5 x 11 x 4 in)	46 x 32 x 10 cm (18 x 12.5 x 4 in)
WEIGHT	140 g (4.9 oz)	210 g (7.3 oz)
MATERIALS	Polyester and Down Cover, Urethane Insert	



Blue / Silver



Coyote / Gray



Limon / Silver



Tomato

## Z Seat™

**Durable, superlight closed-cell camping seat.**

- **Virtually Indestructible:** Puncture-proof closed-cell foam.
- **SOL:** Made with ThermaCapture™ to reflect radiant heat.
- **Compact:** Classic accordion style packs small and carries light; bungee closure keeps your seat contained.

<b>SIZE</b>	<b>One Size</b>
<b>SKU</b>	10786, 09948, 09947
<b>DIMENSIONS</b>	33 x 41 x 1.9 cm (13 x 16 x 0.75 in)
<b>WEIGHT</b>	60 g (2 oz)
<b>THICKNESS</b>	2 cm (0.75 in)
<b>MATERIALS</b>	Cross-linked Polyethylene
<b>FABRIC</b>	50D Polyester
<b>FILL</b>	

## Trekker™ Chair

**Lightweight kit to turn your mattress into a chair.**

- **Ultralight Luxury:** So compact, light and incredibly relaxing you may never travel without a chair again.
- **Easy to Use:** Quick set-up; packs small when not in use.
- **Versatile Design:** Two widths fit most NeoAir and self-inflating pads.

<b>SIZE</b>	<b>20 in</b>
<b>SKU</b>	09533
<b>DIMENSIONS</b>	51 x 114 x 5 cm (20 x 45 x 2 in)
<b>WEIGHT</b>	290 g (10 oz)
<b>THICKNESS</b>	
<b>MATERIALS</b>	Fiberglass stays
<b>FABRIC</b>	75D Ripstop Polyester
<b>FILL</b>	



Green



Blue



Heat Wave



Nautical Blue

## Lite™ Seat

Wherever the trail takes you, the Lite Seat has your backside.

- **Self-Inflating:** Easily adjust the firmness of your seat at camp or on the trail.
- **Packable:** Updated closure bungee keeps your seat rolled up tight in your pack.

SIZE	One Size
SKU	10784, 10804, 13717
DIMENSIONS	33 x 41 x 3.8 cm (13 x 16 x 1.5 in)
WEIGHT	113 g (4 oz)
THICKNESS	3.8 cm (1.5 in)
MATERIALS	Die-Cut Urethane Foam
FABRIC	50D Polyester
FILL	

## Lumbar Pillow

Add back support to any seat.

- **Relieve Pressure:** Die-cut and solid foam combine to reduce spinal pressure.
- **Adjustable:** Self-inflation allows for quick one-handed adjustments.

SIZE	One Size
SKU	06438
DIMENSIONS	18 x 36 x 6 cm (7 x 16 x 2.4 in)
WEIGHT	102 g (3.6 oz)
MATERIALS	Die-Cut Urethane Foam

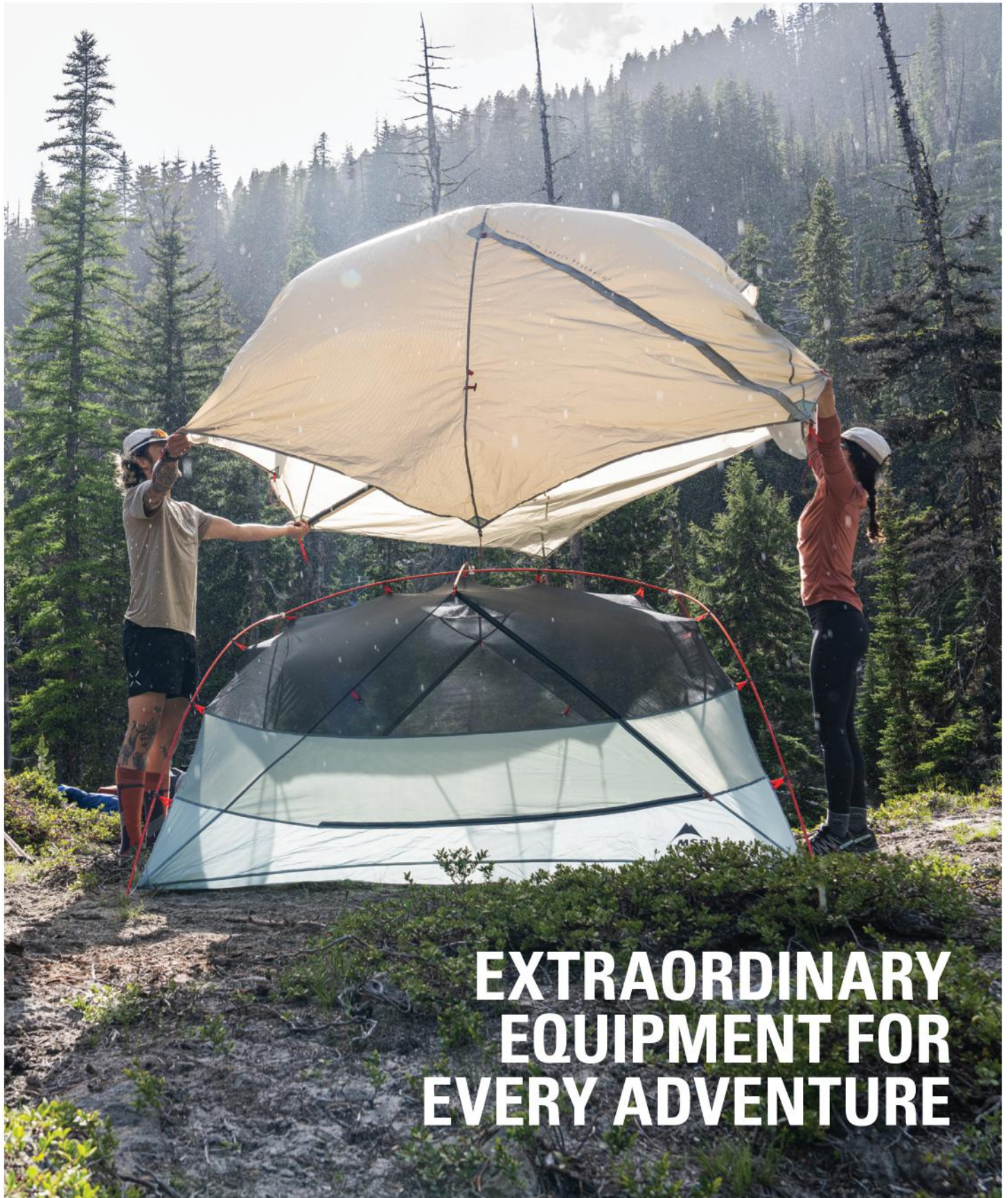

**EXTRAORDINARY  
EQUIPMENT FOR  
EVERY ADVENTURE**

# MSR® TENTS & SHELTERS

## CLASSIC TENTS, REFRESHED

Two beloved MSR tent families have been refreshed for 2026. The updated Elixir gets a new look and performance improvements, and the all-new Hubba Hubba LT and HD tents brings new aesthetics and performance to the Hubba family. All three models have larger floorplans than ever before to accommodate modern wide sleeping pads like the NeoLoft™, and all receive premium all-metal corner hardware.



### EXPANDED FLOORPLANS

Each tent series now offers more living space than ever before, with increased interior volumes that easily accommodate modern wide sleeping pads like the NeoLoft™.

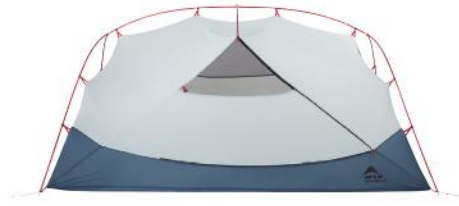

### NEW DOOR ZIPPERS

New straight zipper doors increase durability and are easier for campers to use and find in the middle of the night.



### NEW CORNER HARDWARE

New premium all-metal hardware increases durability for years of use and elevates tent quality.

## UPDATED – ELIXIR™ TENT SERIES

In addition to the size increase and new hardware, the Elixir tents have received a few other updates, ensuring that beginner and comfort-focused backpackers and those looking for a versatile front- and backcountry tent will continue to look to the Elixir as their spacious and durable shelter of choice.



### New Look, Always Included Footprint

The updated Elixir has new aesthetics with carefully considered colors and lines but still includes a footprint, perfect for newer users getting into camping and backpacking.

### New Coatings

Fabrics and coatings have been updated to improve hydrolysis resistance, making it more waterproof and extending the longevity of the tent.

# NEW – HUBBA HUBBA™ LT & HUBBA HUBBA™ HD TENTS

The best-selling Hubba tent family gets two new models for 2026, letting users choose the tent best tailored to their environment and needs. The LT is designed for maximum airflow, lightweight comfort and increased livability; the HD is made for exceptional three-season weather protection without sacrificing comfort or a lighter pack.

## Super Breathable

The LT tent body is mostly mesh for peak breathability, condensation management and ultimate star-gazing, and is ideal for warmer climates.



Hubba Hubba LT 2P

Hubba Hubba HD 2P

## Storm Stable

Extra included guylines help keep the HD grounded no matter the weather and let users configure their preferred setup or adapt to any camp spot.

## Heavy-Duty Fabric Coatings

Fabrics and coatings have been updated to improve hydrolysis resistance, making it more waterproof and extending the longevity of the tent.



## IMPROVED VENTS

New large fly vents keep weather out while allowing excellent airflow.



## CAMP IN COMFORT

Increased interior volume, large vestibules to store gear, a clothesline and more pockets make the already spacious Hubbas even more enjoyable.



## LOWER IMPACT

Solution-dyed fly, floor and mesh fabrics use pre-dyed fibers to minimize water usage and reduce carbon emissions by at least 80% compared to our previous fabrics.



## BETTER STUFF SACK

The new side-loading roll-top stuff sack makes putting the tent away faster and easier than a traditional top-loading bag.



## MINI-GROUNDHOG™ STAKES

For better performance in all ground conditions, the eight included stakes are everyone's favorite, the Mini-Groundhog.

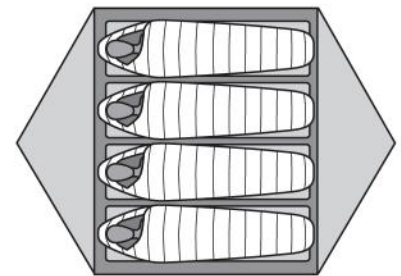

## 3+ ADAPTABILITY

The 3-person Hubba in both models are so spacious, they can accommodate four regular NeoLoft pads laid out horizontally.

# 2026 TENTS & SHELTERS | LINE PLAN

€€€



HUBBA HUBBA™ HD 1P



HUBBA HUBBA™ HD 2P



HUBBA HUBBA™ HD 3P



HUBBA HUBBA™ BIKEPACK 1P



HUBBA HUBBA™ BIKEPACK 2P



HUBBA HUBBA™ LT 1P



HUBBA HUBBA™ LT 2P



HUBBA HUBBA™ LT 3P



FREELITE™ 1P



FREELITE™ 2P



FREELITE™ 3P



TINDHEIM™ 2P



TINDHEIM™ 3P



ELIXIR™ 1P



ELIXIR™ 2P



ELIXIR™ 3P



ELIXIR™ 4P

€

BACKPACKING/BIKEPACKING

# 2026 TENTS & SHELTERS | LINE PLAN

€€€



REMOTE™ 2



REMOTE™ 3



ACCESS™ 1P



ACCESS™ 2P



ACCESS™ 3P



ADVANCE PRO™ 2P



THRU-HIKER  
70 WING

THRU-HIKER  
100 WING



E-BIVY™



FRONT RANGE™ INSERT



FRONT RANGE™ 4P



PRO BIVY™

€

TARPS, BIVIES & SHELTERS

ALL-SEASON

NEW

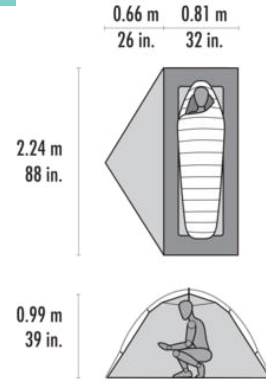

Olive Night

## Hubba Hubba™ HD 1 Tent

Spacious, lightweight comfort for a solo backpacker who's not afraid of a less-than-favorable weather forecast.

- **Maximum 3-season Protection:** Heavy-duty coatings, stable poles and less mesh provide durable weather resistance; larger vestibules protect gear in bad weather.
- **More Space, Less Weight:** True rectangular floor and large interior volume offer more living space for less weight and accommodates a wider sleeping pad.
- **Smart Details:** Extra pockets, rainfly with StayDry™ door, clothesline, new roll-top stuff sack, and easy-to-find, no-curve door zips for quick entry and exit.
- **Easy Setup:** Symmetrical design and locking metal stake loop grommets make tent setup fast and simple.
- **Lower Impact:** Solution-dyed fly, floor and mesh fabrics use pre-dyed fibers to reduce carbon emissions by at least 80% versus our previous fabrics.

SIZE	One Size
SKU	13939
CAPACITY	1
WEIGHT	MINIMUM: 1200 g (42 oz) PACKAGED: 1360 g (48 oz)
FLOOR + VESTIBULE	1.81 + 85 sq. m (19.5 + 9.2 sq. ft)
INTERIOR PEAK HEIGHT	99 cm (39 in)
POLES	(1) DAC NFL 8.7mm
RAINFLY FABRIC	20D ripstop nylon 3000mm polyether urethane & PFAS-free silicone, FR Free
CANOPY FABRIC	Solution-dyed 20D polyester micromesh / 20D ripstop nylon & PFAS-free DWR
FLOOR FABRIC	30D ripstop nylon 6000mm polyether urethane & PFAS-free DWR

NEW

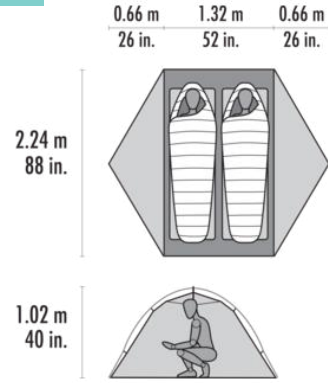

Olive Night

## Hubba Hubba™ HD 2 Tent

Made for backpackers who need reliable 3-season weather protection without sacrificing weight savings or livability.

- **Maximum 3-season Protection:** Heavy-duty coatings, stable poles and less mesh provide durable weather resistance; larger vestibules protect gear in bad weather.
- **More Space, Less Weight:** True rectangular floor and large interior volume offer more living space for less weight and accommodates wider sleeping pads.
- **Smart Details:** Extra pockets, rainfly with StayDry™ doors, clothesline, new roll-top stuff sack, and easy-to-find, no-curve door zips for quick entry and exit.
- **Easy Setup:** Symmetrical design and locking metal stake loop grommets make tent setup fast and simple.
- **Lower Impact:** Solution-dyed fly, floor and mesh fabrics use pre-dyed fibers to reduce carbon emissions by at least 80% versus our previous fabrics.

SIZE	One Size
SKU	13940
CAPACITY	2
WEIGHT	MINIMUM: 1610 g (57 oz) PACKAGED: 1800 g (63 oz)
FLOOR + VESTIBULE	3 + 85.1 sq. m (31.8 + 9.2 sq. ft)
INTERIOR PEAK HEIGHT	101.6 cm (40 in)
POLES	(1) DAC NFL 9.3mm
RAINFLY FABRIC	20D ripstop nylon 3000mm polyether urethane & PFAS-free silicone, FR Free
CANOPY FABRIC	Solution-dyed 20D polyester micromesh / 20D ripstop nylon & PFAS-free DWR
FLOOR FABRIC	30D ripstop nylon 6000mm polyether urethane & PFAS-free DWR

NEW



Olive Night

## Hubba Hubba™ HD 3 Tent

Plenty of room for 3 or even 4 adventurers who want lightweight, reliable weather protection without missing out on camp comforts.

- **Maximum 3-season Protection:** Heavy-duty coatings, stable poles and less mesh provide durable weather resistance; larger vestibules protect gear in bad weather.
- **More Space, Less Weight:** True rectangular floor and large interior volume offer more living space for less weight and accommodates wider sleeping pads.
- **Smart Details:** Extra pockets, rainfly with StayDry™ doors, clothesline, new roll-top stuff sack, and easy-to-find, no-curve door zips for quick entry and exit.
- **Easy Setup:** Symmetrical design and locking metal stake loop grommets make tent setup fast and simple.
- **Lower Impact:** Solution-dyed fly, floor and mesh fabrics use pre-dyed fibers to reduce carbon emissions by at least 80% versus our previous fabrics.

SIZE	One Size
SKU	13941
CAPACITY	3
WEIGHT	MINIMUM: 2200 g (78 oz) PACKAGED: 2360 g (83 oz)
FLOOR + VESTIBULE	4.4 + 87.1 sq. m (46.9 + 9.4 sq. ft)
INTERIOR PEAK HEIGHT	106.7 cm (42 in)
POLES	(1) DAC NSL 9.6/10.25mm
RAINFLY FABRIC	20D ripstop nylon 3000mm polyether urethane & PFAS-free silicone, FR Free
CANOPY FABRIC	Solution-dyed 20D polyester micromesh / 20D ripstop nylon & PFAS-free DWR
FLOOR FABRIC	30D ripstop nylon 6000mm polyether urethane & PFAS-free DWR

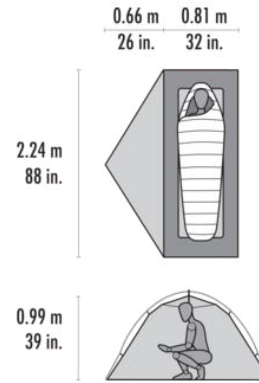

Olive Night

## Hubba Hubba™ LT 1 Tent

The most breathable, livable solo freestanding tent for backpacking or multisport adventures.

- **Proven Seller:** The Hubba Hubba tents are legendary, holding a place in the hearts and minds of backpackers and campers the world over.
- **More Room:** Added space in every direction delivers a more refined camping experience, with plenty of room for a bigger, thicker air pad.
- **More Ventilation:** We've added more mesh, maximizing air flow, ventilation and views.
- **Refined Details:** All-metal corner hardware, easy-to-use roll-top stuff sack, and updated fly vents for a better overall experience.
- **Lower Impact:** Solution-dyed fly, floor and mesh fabrics use pre-dyed fibers to reduce carbon emissions by at least 80% versus our previous fabrics.

SIZE	One Size
SKU	14306
CAPACITY	1
WEIGHT	MINIMUM: 1070 g (38 oz) PACKAGED: 1230 g (43 oz)
FLOOR + VESTIBULE	1.82 + 0.74 sq. m (20 + 8 sq. ft)
INTERIOR PEAK HEIGHT	99 cm (39 in)
POLES	(1) DAC NFL 8.7mm
RAINFLY FABRIC	Solution-dyed 20D ripstop nylon, 1200 mm polyether urethane & PFAS-free silicone
CANOPY FABRIC	Solution-dyed 20D polyester micromesh / 20D ripstop nylon & PFAS-free DWR
FLOOR FABRIC	Solution-dyed 20D ripstop nylon, 1800 mm polyether urethane & PFAS-free DWR

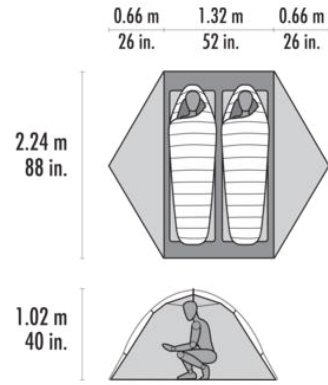

Olive Night

## Hubba Hubba™ LT 2 Tent

Light and airy with extra room for the new wave of luxury sleeping pads.

- **Proven Seller:** The Hubba Hubba tents are legendary, holding a place in the hearts and minds of backpackers and campers the world over.
- **More Room:** Added space in every direction delivers a more refined camping experience, with plenty of room for bigger, thicker air pads.
- **More Ventilation:** We've added more mesh, maximizing air flow, ventilation and views.
- **Refined Details:** All-metal corner hardware, easy-to-use roll-top stuff sack, and updated fly vents for a better overall experience.
- **Lower Impact:** Solution-dyed fly, floor and mesh fabrics use pre-dyed fibers to reduce carbon emissions by at least 80% versus our previous fabrics.

SIZE	One Size
SKU	14307
CAPACITY	2
WEIGHT	MINIMUM: 1360 g (48 oz) PACKAGED: 1540 g (54 oz)
FLOOR + VESTIBULE	2.95 + 1.48 sq. m (32 + 16 sq. ft)
INTERIOR PEAK HEIGHT	102 cm (40 in)
POLES	(1) DAC NFL 9.3mm
RAINFLY FABRIC	Solution-dyed 20D ripstop nylon, 1200 mm polyether urethane & PFAS-free silicone
CANOPY FABRIC	Solution-dyed 20D polyester micromesh / 20D ripstop nylon & PFAS-free DWR
FLOOR FABRIC	Solution-dyed 20D ripstop nylon, 1800 mm polyether urethane & PFAS-free DWR



Olive Night

## Hubba Hubba™ LT 3 Tent

**Roomy, and we mean it; sleeps up to four people, with ample room for three to camp in luxury.**

- **Proven Seller:** The Hubba Hubba tents are legendary, holding a place in the hearts and minds of backpackers and campers the world over.
- **More Room:** Added space in every direction delivers a more refined camping experience, with plenty of room for bigger, thicker air pads.
- **More Ventilation:** We've added more mesh, maximizing air flow, ventilation and views.
- **Refined Details:** All-metal corner hardware, easy-to-use roll-top stuff sack, and updated fly vents for a better overall experience.
- **Lower Impact:** Solution-dyed fly, floor and mesh fabrics use pre-dyed fibers to reduce carbon emissions by at least 80% versus our previous fabrics.

SIZE	One Size
SKU	14308
CAPACITY	3
WEIGHT	MINIMUM: 1980 g (70 oz) PACKAGED: 2170 g (77 oz)
FLOOR + VESTIBULE	4.35 + 1.51 sq. m (47 + 16 sq. ft)
INTERIOR PEAK HEIGHT	107 cm (42 in)
POLES	(1) DAC NSL 9.6/10.25mm
RAINFLY FABRIC	Solution-dyed 20D ripstop nylon, 1200 mm polyether urethane & PFAS-free silicone
CANOPY FABRIC	Solution-dyed 20D polyester micromesh / 20D ripstop nylon & PFAS-free DWR
FLOOR FABRIC	Solution-dyed 20D ripstop nylon, 1800 mm polyether urethane & PFAS-free DWR

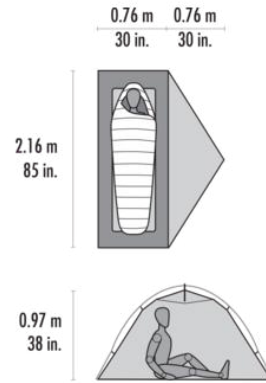

Green

## Hubba Hubba™ Bikepack 1 Tent

Three-season solo tent optimized for bikepacking and touring.

- **Built Light:** Engineered to keep overall bike weight down.
- **Custom Carry:** Waterproof handlebar bag with included spacers mounts seamlessly on drop and flat bars.
- **Sized Right:** Strong DAC pole sections break down smaller to fit between handlebars and in panniers and frame bags.
- **Made for Living:** Interior clothesline, storage pockets with cable ports, generous interior space, and great ventilation add comfort and convenience.
- **Easy Setup:** Unified hub-and-pole system and symmetrical design make setup super-quick.

SIZE	One Size
SKU	13706
CAPACITY	1
WEIGHT	MINIMUM: 930 g (33 oz) PACKAGED: 1270 g (45 oz)
FLOOR + VESTIBULE	1.67 + 0.82 sq. m (18 + 9 sq. ft)
INTERIOR PEAK HEIGHT	97 cm (38 in)
POLES	(2) DAC NSL 8.5mm
RAINFLY FABRIC	20D ripstop nylon 1200mm polyether urethane & PFAS-free silicone, FR Free
CANOPY FABRIC	10D polyester micromesh / 20D ripstop nylon & PFAS-free DWR
FLOOR FABRIC	20D ripstop nylon 1200mm polyether urethane & PFAS-free DWR

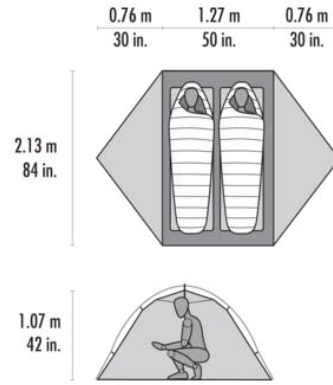

Green

## Hubba Hubba™ Bikepack 2 Tent

Three-season, 2-person tent optimized for bikepacking and touring.

- **Built Light:** Engineered to keep overall bike weight down.
- **Custom Carry:** Waterproof handlebar bag with included spacers mounts seamlessly on drop and flat bars.
- **Sized Right:** Strong DAC pole sections break down smaller to fit between handlebars and in panniers and frame bags.
- **Made for Living:** Interior clothesline, storage pockets with cable ports, generous interior space, and great ventilation add comfort and convenience.
- **Easy Setup:** Unified hub-and-pole system and symmetrical design make setup super-quick.

SIZE	One Size
SKU	13707
CAPACITY	2
WEIGHT	MINIMUM: 1400 g (49 oz) PACKAGED: 1710 g (60 oz)
FLOOR + VESTIBULE	2.70 + 1.63 sq. m (29 + 17.5 sq. ft)
INTERIOR PEAK HEIGHT	107 cm (42 in)
POLES	(2) DAC NSL 8.5mm
RAINFLY FABRIC	20D ripstop nylon 1200mm polyether urethane & PFAS-free silicone, FR Free
CANOPY FABRIC	10D polyester micromesh / 20D ripstop nylon & PFAS-free DWR
FLOOR FABRIC	20D ripstop nylon 1200mm polyether urethane & PFAS-free DWR

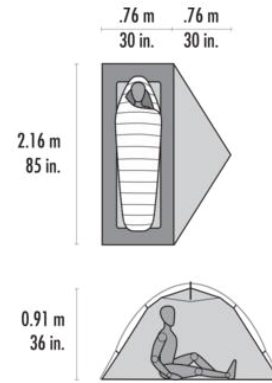

Gray

Green

## Hubba™ NX 1-Person Backpacking Tent

The ultimate one-person, go-anywhere backpacking tent.

- **Proven Seller:** Hubba Hubba tents are legendary best sellers, holding a place in the hearts and minds of backpackers and campers the world over.
- **Maximum Space:** Head and elbow room throughout tent; large side-entry vestibule to store gear.
- **Livable:** Two large StayDry™ doors with built-in rain gutters; adaptable, cross-ventilating rainfly.
- **Easy Setup:** Unified hub-and-pole system with color-coded clips.
- **Ultralight and Packable:** Weighs just over 1 kg and packs small with included compression stuff sack.

SIZE	One Size (PFAS)
SKU	02746, 06203
CAPACITY	1
WEIGHT	MINIMUM: 1120 g (39 oz) PACKAGED: 1290 g (46 oz)
FLOOR + VESTIBULE	1.67 + 0.84 sq. m (18 + 9 sq. ft)
INTERIOR PEAK HEIGHT	91 cm (36 in)
POLES	(1) DAC Featherlite NFL
RAINFLY FABRIC	20D ripstop nylon 1200mm Durashield™ polyurethane & silicone
CANOPY FABRIC	20D ripstop nylon
FLOOR FABRIC	30D ripstop nylon 3000mm Durashield™ polyurethane & DWR

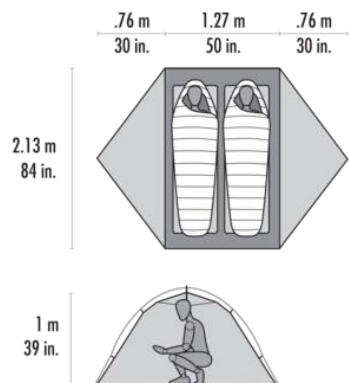

Gray

Green

## Hubba Hubba™ NX 2-Person Backpacking Tent

**Unmatched versatility for two-person backcountry travel.**

- **Proven Seller:** Hubba Hubba tents are legendary best sellers, holding a place in the hearts and minds of backpackers and campers the world over.
- **Maximum Space:** Head and elbow room throughout tent; large side entry vestibules to store gear.
- **Livable:** Two large StayDry™ doors with built-in rain gutters; adaptable, cross-ventilating rainfly.
- **Easy Setup:** Unified hub-and-pole system with color-coded clips.
- **Ultralight and Packable:** Weighs just over 1.5 kg and packs small with included compression stuff sack.

SIZE	One Size (PFAS)
SKU	02750, 06204
CAPACITY	2
WEIGHT	MINIMUM: 1540 g (55 oz) PACKAGED: 1720 g (61 oz)
FLOOR + VESTIBULE	2.7 + 1.62 (.81 + .81) sq. m (29 + 17.5 (8.75 + 8.75) sq. ft)
INTERIOR PEAK HEIGHT	100 cm (39 in)
POLES	(1) DAC Featherlite NFL
RAINFLY FABRIC	20D ripstop nylon 1200mm Durashield™ polyurethane & silicone
CANOPY FABRIC	20D ripstop nylon
FLOOR FABRIC	30D ripstop nylon 3000mm Durashield™ polyurethane & DWR

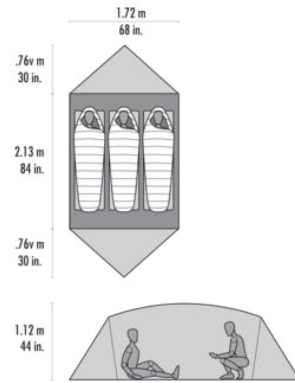

Gray

Green

## Mutha Hubba™ NX 3-Person Backpacking Tent

An honest “3” with ample room for three people plus gear.

- **Proven Seller:** Hubba Hubba tents are legendary best sellers, holding a place in the hearts and minds of backpackers and campers the world over.
- **Maximum Space:** Head and elbow room throughout tent; large side entry vestibules to store gear.
- **Livable:** Large StayDry™ doors with built-in rain gutter; adaptable, cross-ventilating rainfly.
- **Easy Setup:** Unified hub-and-pole system with color-coded clips.
- **Ultralight and Packable:** Weighs just over 2 kg and packs small with included compression stuff sack.

SIZE	One Size (PFAS)
SKU	05839, 09304
CAPACITY	3
WEIGHT	MINIMUM: 2070 g (73 oz) PACKAGED: 2260 g (80 oz)
FLOOR + VESTIBULE	3.67 + 1.3 sq. m (39 + 14 sq. ft)
INTERIOR PEAK HEIGHT	112 cm (44 in)
POLES	(1) DAC Pressfit
RAINFLY FABRIC	20D ripstop nylon 1200mm Durashield™ polyurethane & silicone
CANOPY FABRIC	20D ripstop nylon
FLOOR FABRIC	30D ripstop nylon 3000mm Durashield™ polyurethane & DWR

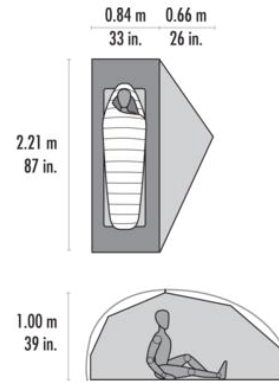

Sahara

Green

## FreeLite™ 1 Tent

The ultimate choice for minimizing weight without compromising livability on high-mileage solo journeys.

- **Ultralight Protection:** Our lightest semi-freestanding solo tent.
- **Full Featured:** Roomy vestibule, large door, and interior gear pockets; ample room for 25"-wide mattresses and sitting up comfortably.
- **Excellent Ventilation:** Full mesh canopy offers maximum moisture control and bug-free nights.
- **Durable Protection:** DAC aluminum poles and proven waterproof coatings provide reliable 3-season protection.

SIZE	One Size (PFAS)
SKU	11511, 11514
CAPACITY	1
WEIGHT	MINIMUM: 740 g (26 oz) PACKAGED: 890 g (31 oz)
FLOOR + VESTIBULE	1.85 + 0.74 sq. m (20 + 8 sq. ft)
INTERIOR PEAK HEIGHT	100 cm (39 in)
POLES	(2) DAC NFL 8.7mm
RAINFLY FABRIC	15D ripstop nylon 1200mm Durashield™ polyurethane & silicone
CANOPY FABRIC	10D Polyester micromesh
FLOOR FABRIC	15D ripstop nylon 1200mm Durashield™ polyurethane & DWR

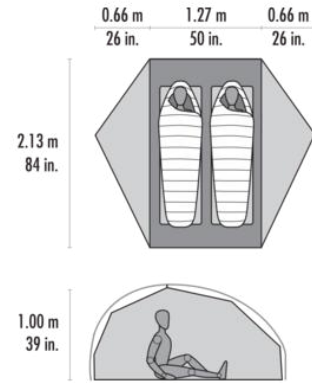

Sahara



Green

## FreeLite™ 2 Tent

The ultimate choice for minimizing weight without compromising livability on high-mileage journeys for backpacking duos.

- **Ultralight Protection:** Our lightest semi-freestanding 2-person tent.
- **Full Featured:** Two vestibules, two large doors, and interior gear pockets; ample room for 25"-wide mattresses and sitting up comfortably.
- **Excellent Ventilation:** Full mesh canopy offers maximum moisture control and bug-free nights.
- **Durable Protection:** DAC aluminum poles and proven waterproof coatings provide reliable 3-season protection.

SIZE	One Size (PFAS)
SKU	11512, 11515
CAPACITY	2
WEIGHT	MINIMUM: 910 g (32 oz) PACKAGED: 1060 g (37 oz)
FLOOR + VESTIBULE	2.7 + 1.4 sq. m (29 + 15 sq. ft)
INTERIOR PEAK HEIGHT	100 cm (39 in)
POLES	(2) DAC NFL 8.7mm
RAINFLY FABRIC	15D ripstop nylon 1200mm Durashield™ polyurethane & silicone
CANOPY FABRIC	10D Polyester micromesh
FLOOR FABRIC	15D ripstop nylon 1200mm Durashield™ polyurethane & DWR

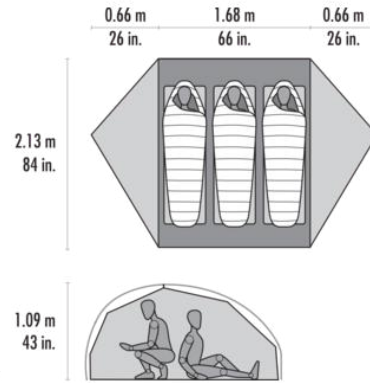

Sahara

Green

## FreeLite™ 3 Tent

For a trio looking to minimize weight without compromising livability on high-mileage journeys.

- **Ultralight Protection:** Our lightest semi-freestanding 3-person tent.
- **Full Featured:** Two vestibules, two large doors, and interior gear pockets; ample room for sitting up comfortably.
- **Excellent Ventilation:** Full mesh canopy offers maximum moisture control and bug-free nights.
- **Durable Protection:** DAC aluminum poles and proven waterproof coatings provide reliable 3-season protection.

SIZE	One Size (PFAS)
SKU	11513, 11516
CAPACITY	3
WEIGHT	MINIMUM: 1070 g (38 oz) PACKAGED: 1230 g (43 oz)
FLOOR + VESTIBULE	3.57 + 1.4 sq. m (38.5 + 15 sq. ft)
INTERIOR PEAK HEIGHT	109 cm (43 in)
POLES	(2) DAC NFL 8.7mm
RAINFLY FABRIC	15D ripstop nylon 1200mm Durashield™ polyurethane & silicone
CANOPY FABRIC	10D Polyester micromesh
FLOOR FABRIC	15D ripstop nylon 1200mm Durashield™ polyurethane & DWR

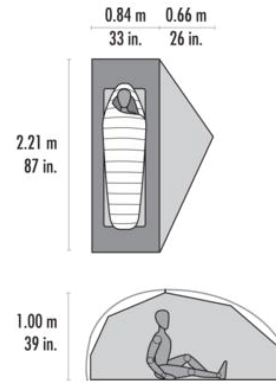

Green

## FreeLite™ 1 Tent

The ultimate choice for minimizing weight without compromising livability on high-mileage solo journeys.

- **Ultralight Protection:** Our lightest semi-freestanding solo tent.
- **Full Featured:** Roomy vestibule, large door, and interior gear pockets; ample room for 25"-wide mattresses and sitting up comfortably.
- **Excellent Ventilation:** Full mesh canopy offers maximum moisture control and bug-free nights.
- **Durable Protection:** DAC aluminum poles and proven waterproof coatings provide reliable 3-season protection.

SIZE	One Size
SKU	14147
CAPACITY	1
WEIGHT	MINIMUM: 740 g (26 oz) PACKAGED: 890 g (31 oz)
FLOOR + VESTIBULE	1.85 + 0.74 sq. m (20 + 8 sq. ft)
INTERIOR PEAK HEIGHT	100 cm (39 in)
POLES	(2) DAC NFL 8.7mm
RAINFLY FABRIC	15D ripstop nylon 1200mm polyether urethane and PFAS-free DWR
CANOPY FABRIC	10D polyester micromesh
FLOOR FABRIC	15D ripstop nylon 1200mm polyether urethane and PFAS-free DWR

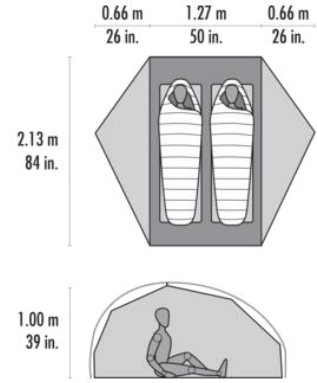

Green

## FreeLite™ 2 Tent

The ultimate choice for minimizing weight without compromising livability on high-mileage journeys for backpacking duos.

- **Ultralight Protection:** Our lightest semi-freestanding 2-person tent.
- **Full Featured:** Two vestibules, two large doors, and interior gear pockets; ample room for 25"-wide mattresses and sitting up comfortably.
- **Excellent Ventilation:** Full mesh canopy offers maximum moisture control and bug-free nights.
- **Durable Protection:** DAC aluminum poles and proven waterproof coatings provide reliable 3-season protection.

<b>SIZE</b>	<b>One Size</b>
<b>SKU</b>	14148
<b>CAPACITY</b>	2
<b>WEIGHT</b>	MINIMUM: 910 g (32 oz) PACKAGED: 1060 g (37 oz)
<b>FLOOR + VESTIBULE</b>	2.7 + 1.4 sq. m (29 + 15 sq. ft)
<b>INTERIOR PEAK HEIGHT</b>	100 cm (39 in)
<b>POLES</b>	(2) DAC NFL 8.7mm
<b>RAINFLY FABRIC</b>	15D ripstop nylon 1200mm polyether urethane and PFAS-free DWR
<b>CANOPY FABRIC</b>	10D polyester micromesh
<b>FLOOR FABRIC</b>	15D ripstop nylon 1200mm polyether urethane and PFAS-free DWR

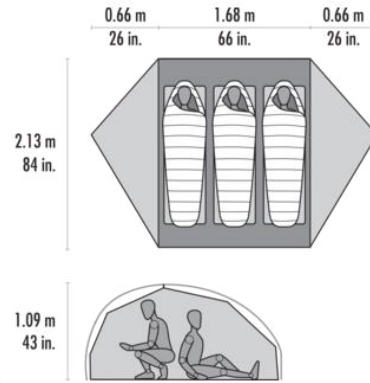

Green

## FreeLite™ 3 Tent

For a trio looking to minimize weight without compromising livability on high-mileage journeys.

- **Ultralight Protection:** Our lightest semi-freestanding 3-person tent.
- **Full Featured:** Two vestibules, two large doors, and interior gear pockets; ample room for sitting up comfortably.
- **Excellent Ventilation:** Full mesh canopy offers maximum moisture control and bug-free nights.
- **Durable Protection:** DAC aluminum poles and proven waterproof coatings provide reliable 3-season protection.

SIZE	One Size
SKU	14149
CAPACITY	3
WEIGHT	MINIMUM: 1070 g (38 oz) PACKAGED: 1230 g (43 oz)
FLOOR + VESTIBULE	3.57 + 1.4 sq. m (38.5 + 15 sq. ft)
INTERIOR PEAK HEIGHT	109 cm (43 in)
POLES	(2) DAC NFL 8.7mm
RAINFLY FABRIC	15D ripstop nylon 1200mm polyether urethane and PFAS-free DWR
CANOPY FABRIC	10D polyester micromesh
FLOOR FABRIC	15D ripstop nylon 1200mm polyether urethane and PFAS-free DWR

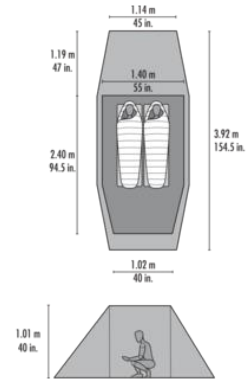

Olive Green

## Tindheim™ 2 Tent

**Three-season comfort and dependability for adventurous duos in any weather.**

- **Unique Strength:** Classic tunnel design delivers reliable strength, space and protection for trips from spring through fall.
- **Storm-Pitch:** Integrated body and fly allow fast, easy pitching; inner tent stays dry when pitching in the rain.
- **Weather-Ready:** Strong two-hoop design, multiple reflective guy cords and points, roomy vestibule, and adjustable cord stake loops.
- **Spacious Interior:** Easily accommodates two people plus gear, even when hunkered down in a multi-day storm.

SIZE	One Size (PFAS)
SKU	10832
CAPACITY	2
WEIGHT	MINIMUM: 2480 g (87 oz) PACKAGED: 3200 g (113 oz)
FLOOR + VESTIBULE	3.11 + 1.49 sq. m (33.5 + 16 sq. ft)
INTERIOR PEAK HEIGHT	101 cm (40 in)
POLES	(2) Aluminum 7000 Series
RAINFLY FABRIC	68D polyester 1500mm polyurethane & DWR
CANOPY FABRIC	68D taffeta polyester & DWR
FLOOR FABRIC	68D taffeta polyester 3000mm polyurethane & DWR

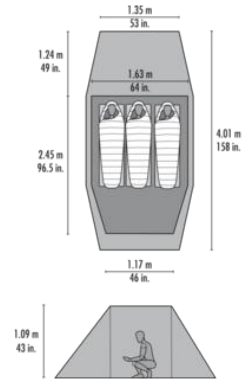

Olive Green

## Tindheim™ 3 Tent

Enough space and storage for a trio on three-season adventures, no matter the weather.

- **Unique Strength:** Classic tunnel design delivers reliable strength, space and protection for trips from spring through fall.
- **Storm-Pitch:** Integrated body and fly allow fast, easy pitching; inner tent stays dry when pitching in the rain.
- **Weather-Ready:** Strong two-hoop design, multiple reflective guy cords and points, roomy vestibule, and adjustable cord stake loops.
- **Spacious Interior:** Easily accommodates three people plus gear, even when hunkered down in a multi-day storm.

SIZE	One Size (PFAS)
SKU	10833
CAPACITY	3
WEIGHT	MINIMUM: 2910 g (103 oz) PACKAGED: 3730 g (132 oz)
FLOOR + VESTIBULE	3.67 + 1.76 sq. m (39.5 + 19 sq. ft)
INTERIOR PEAK HEIGHT	109 cm (43 in)
POLES	(2) Aluminum 7000 Series
RAINFLY FABRIC	68D polyester 1500mm polyurethane & DWR
CANOPY FABRIC	68D taffeta polyester & DWR
FLOOR FABRIC	68D taffeta polyester 3000mm polyurethane & DWR

UPDATED

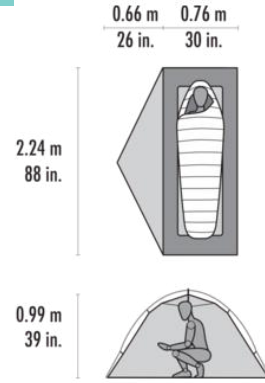

Green

## Elixir™ 1 Tent

The most livable solo backpacking tent in its class.

- **So Much Room:** Bring your pack inside, roll around, sit up, and sleep on a 25-inch (63.5-cm) mattress, no problem at all.
- **Privacy & Ventilation:** A mix of solution-dyed mesh and solid fabric panels offers a balance of ventilation, warmth, and privacy.
- **Easy Setup:** Freestanding design, color-coded poles and webbing, and included footprint make for fast and intuitive setup; easy-to-find, no-curve door zips for quick entry and exit.
- **Premium Luxury:** Large StayDry™ door, kickstand-vented fly, large side-entry vestibule, and premium metal corner hardware for lasting performance.
- **Stay Organized:** Large gear loft for overhead storage and cable ports on all pockets for easy cord management.

SIZE	One Size
SKU	13698
CAPACITY	1
WEIGHT	MINIMUM: 1840 g (65 oz) PACKAGED: 2330 g (82 oz)
FLOOR + VESTIBULE	1.7 + 0.74 sq. m (18.33 + 8 sq. ft)
INTERIOR PEAK HEIGHT	99 cm (39 in)
POLES	(2) 7000 Series Aluminum
RAINFLY FABRIC	75D ripstop polyester 1500mm polyether urethane & PFAS-free DWR
CANOPY FABRIC	20D nylon micromesh / 40D ripstop polyester & PFAS-free DWR
FLOOR FABRIC	75D taffeta polyester 3000mm polyether urethane & PFAS-free DWR



UPDATED



0.66 m 1.32 m 0.66 m  
26 in. 52 in. 26 in.

2.13 m  
84 in.

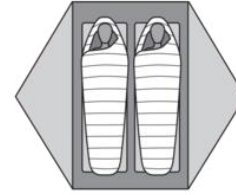

1.04 m  
41 in.



Green

## Elixir™ 2 Tent

More than enough space and storage for two.

- **So Much Room:** Bring your packs inside, roll around, sit up and sleep on 25-inch (63.5-cm) mattresses, no problem at all.
- **Privacy & Ventilation:** A mix of solution-dyed mesh and solid fabric panels offers a balance of ventilation, warmth, and privacy.
- **Easy Setup:** Freestanding design, color-coded poles and webbing, and included footprint make for fast and intuitive setup; easy-to-find, no-curve door zips for quick entry and exit.
- **Premium Luxury:** Two large StayDry™ doors, kickstand-vented fly, large side-entry vestibules and premium metal corner hardware for lasting performance.
- **Stay Organized:** Large gear loft for overhead storage, and cable ports on all pockets for easy cord management.

SIZE	One Size
SKU	13699
CAPACITY	2
WEIGHT	MINIMUM: 2330 g (82 oz) PACKAGED: 2820 g (99 oz)
FLOOR + VESTIBULE	2.8 + 1.41 sq. m (30 + 15 sq. ft)
INTERIOR PEAK HEIGHT	104 cm (41 in)
POLES	(2) 7000 Series Aluminum
RAINFLY FABRIC	75D ripstop polyester 1500mm polyether urethane & PFAS-free DWR
CANOPY FABRIC	20D nylon micromesh / 40D ripstop polyester & PFAS-free DWR
FLOOR FABRIC	75D taffeta polyester 3000mm polyether urethane & PFAS-free DWR

UPDATED

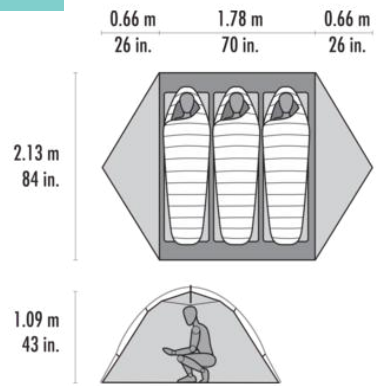

Green

## Elixir™ 3 Tent

**A spacious getaway for three with room to spare.**

- **So Much Room:** Bring your packs inside, roll around, sit up and sleep on 25-inch (63.5-cm) mattresses, no problem at all.
- **Privacy & Ventilation:** A mix of solution-dyed mesh and solid fabric panels offers a balance of ventilation, warmth and privacy.
- **Easy Setup:** Freestanding design, color-coded poles and webbing, and included footprint make for fast and intuitive setup; easy-to-find, no-curve door zips for quick entry and exit.
- **Premium Luxury:** Two large StayDry™ doors, kickstand vented fly, large side-entry vestibules and premium metal corner hardware for lasting performance.
- **Stay Organized:** Large gear loft for overhead storage, and cable ports on all pockets for easy cord management.

SIZE	One Size
SKU	13700
CAPACITY	3
WEIGHT	MINIMUM: 2750 g (97 oz) PACKAGED: 3240 g (114 oz)
FLOOR + VESTIBULE	3.8 + 1.41 sq. m (41 + 15 sq. ft)
INTERIOR PEAK HEIGHT	109 cm (43 in)
POLES	(2) 7000 Series Aluminum
RAINFLY FABRIC	75D ripstop poly 1500mm polyether urethane & PFAS-Free DWR
CANOPY FABRIC	20D nylon micromesh / 40D ripstop polyester & PFAS-Free DWR
FLOOR FABRIC	75D taffeta polyester 3000mm polyether urethane & PFAS-Free DWR



Green

## Elixir™ 4 Tent

**Versatile and large enough for family backpacking or car camping.**

- **So Much Room:** Bring your packs inside, roll around, sit up and sleep on 25-inch (63.5-cm) mattresses, no problem at all.
- **Privacy & Ventilation:** A mix of solution-dyed mesh and solid fabric panels offers a balance of ventilation, warmth and privacy.
- **Easy Setup:** Freestanding design, color-coded poles and webbing, and included footprint make for fast and intuitive setup; easy-to-find, no-curve door zips for quick entry and exit.
- **Premium Luxury:** Two large StayDry™ doors, kickstand vented fly, large side-entry vestibules and premium metal corner hardware for lasting performance.
- **Stay Organized:** Large gear loft for overhead storage, and cable ports on all pockets for easy cord management.

SIZE	One Size
SKU	13701
CAPACITY	4
WEIGHT	MINIMUM: 3720 g (131 oz) PACKAGED: 4210 g (148 oz)
FLOOR + VESTIBULE	5.1 + 1.51 sq. m (55 + 16 sq. ft)
INTERIOR PEAK HEIGHT	122 cm (48 in)
POLES	(2) 7000 Series Aluminum
RAINFLY FABRIC	75D ripstop poly 1500mm polyether urethane & PFAS-Free DWR
CANOPY FABRIC	20D nylon micromesh / 40D ripstop polyester & PFAS-Free DWR
FLOOR FABRIC	75D taffeta polyester 3000mm polyether urethane & PFAS-Free DWR

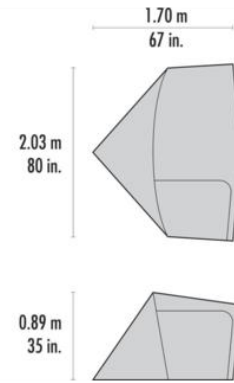

Gray

Green

## MSR Gear Shed for Elixir™ & Hubba Hubba™ Tent Series

Increases the vestibule area of most Elixir, Hubba Hubba and Hubba NX series tents.

- **Added Storage:** Hooped vestibule expands weatherproof storage.
- **Integrated Floor:** Partial floor creates a dry, clean place to store gear out of the way.
- **Versatile:** Turns your backpacking tent into a basecamp tent.
- **Convenient:** Extra-large door and integrated design allow convenient, covered access to gear.
- **Compatibility:** Not compatible with Elixir™ 4, Mutha Hubba™, Papa Hubba™, Hubba Hubba LT or HD tents.

SIZE	One Size (PFAS)
SKU	10314, 10334
CAPACITY	Gear
WEIGHT	MINIMUM: 820 g (29 oz) PACKAGED: 940 g (33 oz)
FLOOR + VESTIBULE	2.46 + 26.5 +
INTERIOR PEAK HEIGHT	89 cm (35 in)
POLES	(1) 7000 Series Aluminum
RAINFLY FABRIC	68D ripstop polyester 1500mm Polyurethane & DWR
CANOPY FABRIC	N/A
FLOOR FABRIC	70D taffeta nylon 3000mm polyurethane & DWR

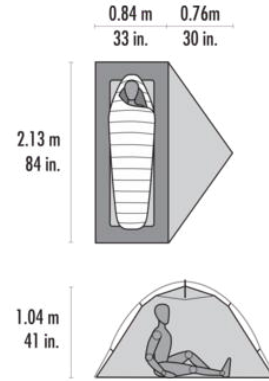

Orange

Green

## Access™ 1 Tent

Ultralight, four-season solo tent for ski touring and snowshoeing.

- **Ultralight Warmth:** Limited mesh on the tent body keeps in all that hard-earned warmth on cold nights, with an overall weight that's easy to carry.
- **Robust Design:** Unique central-support frame; ultra-durable Easton® Syclone™ poles withstand severe conditions and heavy snow loads.
- **Quick Setup:** Unified hubs and poles with color-coded clips.
- **Additional Features:** Rainfly vents reduce condensation; proven waterproof coating for long-term durability; one door; one internal pocket; multiple guy points.

SIZE	One Size (PFAS)
SKU	13116, 13131
CAPACITY	1
WEIGHT	MINIMUM: 1370 g (48 oz) PACKAGED: 1600 g (56 oz)
FLOOR + VESTIBULE	1.76 + 0.23 sq. m (19 + 9 sq. ft)
INTERIOR PEAK HEIGHT	104 cm (41 in)
POLES	(1) Easton® Syclone™
RAINFLY FABRIC	20D ripstop nylon 1200mm Xtreme Shield™ polyurethane & silicone
CANOPY FABRIC	20D ripstop nylon & DWR
FLOOR FABRIC	30D ripstop nylon 3000mm Xtreme Shield™ polyurethane & DWR



Orange

Green

## Access™ 2 Tent

**Ultralight, four-season, 2-person tent for ski touring and snowshoeing.**

- **Ultralight Warmth:** Limited mesh on the tent body keeps in all that hard-earned warmth on cold nights, with an overall weight that's easy to carry.
- **Robust Design:** Unique central-support frame; ultra-durable Easton® Syclone™ poles withstand severe conditions and heavy snow loads.
- **Quick Setup:** Unified hubs and poles with color-coded clips.
- **Additional Features:** Rainfly vents reduce condensation; proven waterproof coating for long-term durability; two doors; two internal pockets; multiple guy points.

SIZE	One Size (PFAS)
SKU	13117, 13132
CAPACITY	2
WEIGHT	MINIMUM: 1640 g (58 oz) PACKAGED: 1860 g (65 oz)
FLOOR + VESTIBULE	2.69 + 1.62 sq. m (29 + 17.5 sq. ft)
INTERIOR PEAK HEIGHT	107 cm (42 in)
POLES	(1) Easton® Syclone™
RAINFLY FABRIC	20D ripstop nylon 1200mm Xtreme Shield™ polyurethane & silicone
CANOPY FABRIC	20D ripstop nylon & DWR
FLOOR FABRIC	30D ripstop nylon 3000mm Xtreme Shield™ polyurethane & DWR



Orange

Green

## Access™ 3 Tent

**Ultralight, four-season 3-person tent for ski touring and snowshoeing.**

- **Ultralight Warmth:** Limited mesh on the tent body keeps in all that hard-earned warmth on cold nights, with an overall weight that's easy to carry.
- **Added Space:** Roomy enough for three, but light enough for two plus gear on extended trips.
- **Robust Design:** Unique central-support frame; ultra-durable Easton® Syclone™ poles withstand severe conditions and heavy snow loads.
- **Quick Setup:** Unified hubs and poles with color-coded clips.
- **Additional Features:** Rainfly vents reduce condensation; proven waterproof coating for long-term durability; two doors; two internal pockets; multiple guy points.

SIZE	One Size (PFAS)
SKU	13118, 13133
CAPACITY	3
WEIGHT	MINIMUM: 1990 g (70 oz) PACKAGED: 2300 g (81 oz)
FLOOR + VESTIBULE	3.80 + 1.62 sq. m (41 + 17.5 sq. ft)
INTERIOR PEAK HEIGHT	119 cm (47 in)
POLES	(1) Easton® Syclone™
RAINFLY FABRIC	20D ripstop nylon 1200mm Xtreme Shield™ polyurethane & silicone
CANOPY FABRIC	20D ripstop nylon & DWR
FLOOR FABRIC	30D ripstop nylon 3000mm Xtreme Shield™ polyurethane & DWR

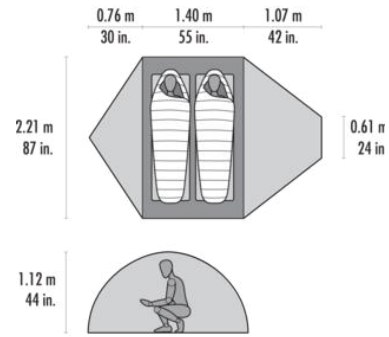

Orange

## Remote™ 2 Tent

**Expedition-grade, all-season double-wall mountaineering tent for two.**

- **Robust Design:** Unique central-support frame; ultra-durable Easton® Syclone™ poles withstand severe conditions and heavy snow loads.
- **Reinforced Guy-Out Points:** Added strength to keep the tent firmly anchored in ferocious winds.
- **Spacious:** Large floor plan and extra headroom create a generous space for two climbers in bulky winter gear; large, hooped vestibule with snow flaps provides protected external storage.
- **Easy Setup:** Color-coded pole clips for quick tent setup in any conditions.
- **Additional Features:** Rainfly vents reduce condensation, DWR-coated, waterproof bathtub floor; two internal pockets; multiple reflective guy points.

SIZE	One Size (PFAS)
SKU	13113
CAPACITY	2
WEIGHT	MINIMUM: 3020 g (107 oz) PACKAGED: 3230 g (114 oz)
FLOOR + VESTIBULE	3.06 + 2.04 sq. m (33 + 22 sq. ft)
INTERIOR PEAK HEIGHT	112 cm (44 in)
POLES	(3) Easton® Syclone™
RAINFLY FABRIC	68D ripstop polyester 1500mm polyurethane & DWR
CANOPY FABRIC	40D ripstop nylon & DWR
FLOOR FABRIC	40D ripstop nylon 10,000mm Durashield™ polyurethane & DWR

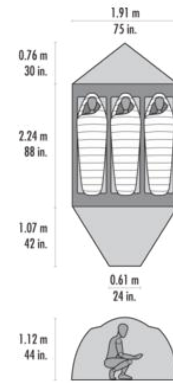

Orange

## Remote™ 3 Tent

**Expedition-grade, all-season double-wall mountaineering tent for three plus gear.**

- **Robust Design:** Unique central-support frame; ultra-durable Easton® Syclone™ poles withstand severe conditions and heavy snow loads.
- **Reinforced Guy-Out Points:** Added strength to keep the tent firmly anchored in ferocious winds.
- **Spacious:** Large floor plan and extra headroom create a generous space for three climbers in bulky winter gear; large, hooped vestibule with snow flaps provides protected external storage.
- **Quick Setup:** Unified hubs and poles with color-coded clips.
- **Additional Features:** Rainfly vents reduce condensation, DWR-coated, waterproof bathtub floor; two internal pockets; multiple reflective guy points.

SIZE	One Size (PFAS)
SKU	13114
CAPACITY	3
WEIGHT	MINIMUM: 3690 g (130 oz) PACKAGED: 3990 g (141 oz)
FLOOR + VESTIBULE	4.27 + 2.04 sq. m (46 + 22 sq. ft)
INTERIOR PEAK HEIGHT	112 cm (44 in)
POLES	(4) Easton® Syclone™
RAINFLY FABRIC	68D ripstop polyester 1500mm polyurethane & DWR
CANOPY FABRIC	40D ripstop nylon & DWR
FLOOR FABRIC	40D ripstop nylon 10,000mm Durashield™ polyurethane & DWR

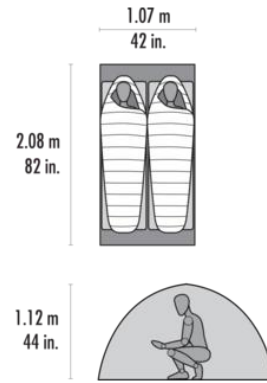

Orange

## Advance Pro™ 2 Tent

The ultimate tent for professional alpinists.

- Rainfly vents reduce condensation.
- Supports first ascents and summit approaches.
- Easton® Syclone™ poles resist breaking in severe winds.
- Small footprint for pitching on a ledge.
- Hybrid clip pole-sleeve sets up in seconds by one person.

SIZE	One Size (PFAS)
SKU	13110
CAPACITY	2
WEIGHT	MINIMUM: 1300 g (46 oz) PACKAGED: 1460 g (51 oz)
FLOOR + VESTIBULE	2.23 + 24 +
INTERIOR PEAK HEIGHT	112 cm (44 in)
POLES	(1) Easton® Syclone™
RAINFLY FABRIC	20D ripstop nylon 2 ply breathable 1000mm
CANOPY FABRIC	N/A
FLOOR FABRIC	30D ripstop nylon 3000mm Xtreme Shield™ polyurethane & DWR



Orange

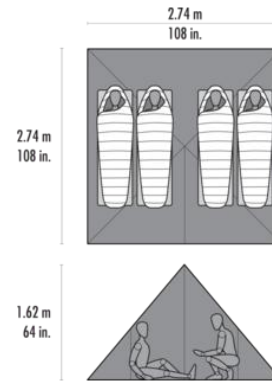

Green

## Front Range™ 4-Person Tarp Shelter

So compact and light, it's hardly noticeable in your pack. The Front Range tarp shelter protects parties of four on giant alpine missions, like spring ski traverses.

- **Ultralight & Spacious:** Comfortably sleeps four with a 5' 4" peak height for gearing up, at just .74 kg (1 lb 10 oz).
- **Quick Setup:** Floorless tarp sets up quickly with ski or trekking poles; ski straps included for easy assembly.
- **Easy Access:** Zippered door rolls back completely on both sides for sweeping views and easy entry.
- **Versatile:** Light enough to carry as a solo shelter, dining hall, or emergency shelter. Optional Bug/Floor Insert available for wet & buggy terrain.
- **Durable:** Steep canopy sheds snow and water and features PEU-waterproof coating for longterm durability.
- Accessory pole sold separately.

SIZE	One Size (PFAS)
SKU	13119, 13313
CAPACITY	4
WEIGHT	MINIMUM: 740 g (26 oz) PACKAGED: 910 g (32 oz)
FLOOR + VESTIBULE	7.52 + 81 +
INTERIOR PEAK HEIGHT	162 cm (64 in)
POLES	N/A
RAINFLY FABRIC	20D ripstop nylon 1200mm Xtreme Shield™ polyurethane & silicone
CANOPY FABRIC	N/A
FLOOR FABRIC	N/A

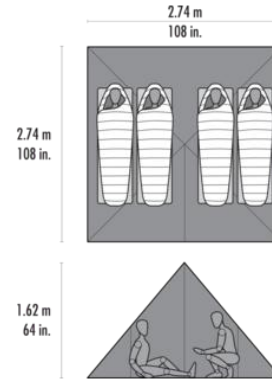

Orange

## Front Range™ 4-Person Tarp Shelter

So compact and light, it's hardly noticeable in your pack. The Front Range tarp shelter protects parties of four on giant alpine missions, like spring ski traverses.

- **Ultralight & Spacious:** Comfortably sleeps four with a 5' 4" peak height for gearing up, at just .74 kg (1 lb 10 oz).
- **Quick Setup:** Floorless tarp sets up quickly with ski or trekking poles; ski straps included for easy assembly.
- **Easy Access:** Zippered door rolls back completely on both sides for sweeping views and easy entry.
- **Versatile:** Light enough to carry as a solo shelter, dining hall, or emergency shelter. Optional Bug/Floor Insert available for wet & buggy terrain.
- **Durable:** Steep canopy sheds snow and water and features PEU-waterproof coating for longterm durability.
- Accessory pole sold separately.

SIZE	One Size
SKU	14113
CAPACITY	4
WEIGHT	MINIMUM: 740 g (26 oz) PACKAGED: 910 g (32 oz)
FLOOR + VESTIBULE	7.52 + 81 +
INTERIOR PEAK HEIGHT	162 cm (64 in)
POLES	N/A
RAINFLY FABRIC	20D ripstop nylon 1200mm polyether urethane & silicone
CANOPY FABRIC	N/A
FLOOR FABRIC	N/A

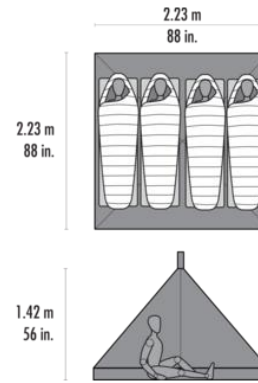

Red

## Front Range™ Bug/Floor Insert

**Turns your Front Range tarp into a full-protection shelter in wet & buggy terrain.**

- Micromesh canopy with durable bathtub floor and zippered door.
- Sets up easily with ski or trekking poles; ski straps included for easy assembly.
- Peak cone keeps fly off mesh.
- Accessory pole sold separately.

<b>SIZE</b>	<b>One Size (PFAS)</b>
<b>SKU</b>	13120
<b>CAPACITY</b>	4
<b>WEIGHT</b>	MINIMUM: 880 g (31 oz) PACKAGED: 1040 g (37 oz)
<b>FLOOR + VESTIBULE</b>	4.97 + 53.5 +
<b>INTERIOR PEAK HEIGHT</b>	142 cm (56 in)
<b>POLES</b>	N/A
<b>RAINFLY FABRIC</b>	
<b>CANOPY FABRIC</b>	15D nylon micro-mesh
<b>FLOOR FABRIC</b>	30D ripstop nylon 3000mm Xtreme Shield™ polyurethane & DWR

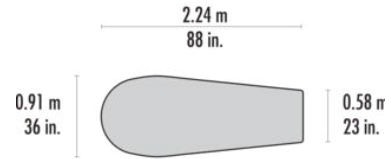

Orange

## Pro™ Bivy

**Weatherproof, breathable bivy for alpinists & fast-and-light adventurers.**

- **Lightweight:** The ultimate in minimalism, supporting fast traverses and technical alpine routes.
- **Breathable:** Weatherproof, breathable fabric helps reduce condensation to keep you dry and comfortable.
- **Weather Protection:** Durable, waterproof coating on bottom and ends lasts up to 3 times longer than standard coatings.
- **Generous Size:** Allows protected storage of additional gear inside.

<b>SIZE</b>	<b>One Size</b>
<b>SKU</b>	10830
<b>CAPACITY</b>	1
<b>WEIGHT</b>	MINIMUM: 280 g (10 oz) PACKAGED: 340 g (12 oz)
<b>FLOOR + VESTIBULE</b>	
<b>INTERIOR PEAK HEIGHT</b>	
<b>POLES</b>	N/A
<b>RAINFLY FABRIC</b>	20D ripstop nylon 2 ply breathable 1000mm
<b>CANOPY FABRIC</b>	N/A
<b>FLOOR FABRIC</b>	15D ripstop nylon 1200mm Xtreme Shield™ polyurethane & DWR

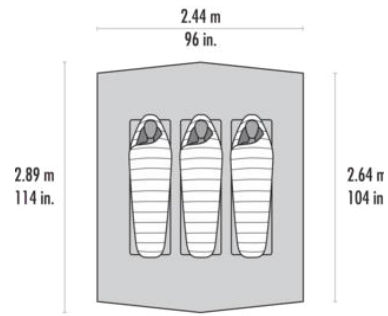

Yellow

## Thru-Hiker 70 Wing Shelter

### Ultra-minimalist shelter for 1-3 people

- **Efficient Traction:** Strong injection-molded ExoTract™ deck with steel crampon and perimeter teeth provides torsional flex and excellent grip for deep purchase in a variety of snow conditions.
- **All-Day Comfort:** Paraglide™ binding stretch mesh hugs feet securely and is compatible with nearly any footwear, from light hikers to snowboard boots.
- **Easy to Use:** Glove-friendly binding straps and buckle tabs make getting in and out quick and simple.
- **Slim Design:** Tapered deck is ideal for women or anyone with a narrow gait.
- **All-Condition Adaptability:** Attachment points for 5-inch (13-cm) modular flotation tails (sold separately), which provide on-demand flotation for deep powder or when carrying heavier loads..
- **Uphill Efficiency:** Ergo™ Televators reduce fatigue and increase traction on the steeps, with an ergonomic design that engages with a flick of a pole grip.

SIZE	One Size
SKU	10827
CAPACITY	2-3
WEIGHT	MINIMUM: 380 g (12 oz) PACKAGED: 460 g (16 oz)
INTERIOR PEAK HEIGHT	Variable cm (Variable in)
POLES	N/A
RAINFLY FABRIC	20D ripstop nylon 1200mm Xtreme Shield™ polyurethane & silicone
CANOPY FABRIC	N/A
FLOOR FABRIC	N/A

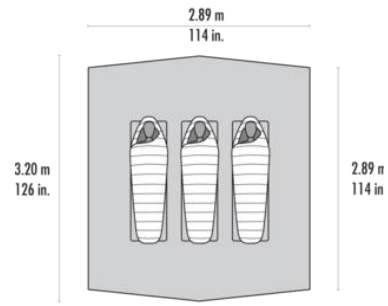

Yellow

## Thru-Hiker 100 Wing Shelter

**Ultra-minimalist shelter that easily accommodates three people.**

- **Traction:** Strong injection-molded ExoTract™ deck with steel crampon and perimeter teeth provides torsional flex and excellent grip for deep purchase in a variety of snow conditions.
- **All-Day Comfort:** Paraglide™ binding stretch mesh hugs feet securely and is compatible with nearly any footwear, from light hikers to snowboard boots.
- **Easy to Use:** Glove-friendly binding straps and buckle tabs make getting in and out quick and simple.
- **All-Condition Adaptability:** Attachment points for 5-inch (13-cm) modular flotation tails (sold separately), which provide on-demand flotation for deep powder or when carrying heavier loads.
- **Uphill Efficiency:** Ergo™ Televators reduce fatigue and increase traction on the steeps, with an ergonomic design that engages with a flick of a pole grip.

SIZE	One Size
SKU	10828
CAPACITY	2-3
WEIGHT	MINIMUM: 490 g (17 oz) PACKAGED: 570 g (20 oz)
INTERIOR PEAK HEIGHT	Variable cm (Variable in)
POLES	N/A
RAINFLY FABRIC	20D ripstop nylon 1200mm Xtreme Shield™ polyurethane & silicone
CANOPY FABRIC	N/A
FLOOR FABRIC	N/A

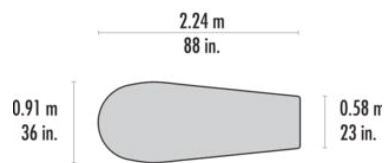

Yellow

## E-Bivy™

**Emergency shelter for backcountry adventures.**

- **Ultralight & Packable:** Ultralight warmth and weather protection that fits in the palm of your hand.
- **Protective:** Water-resistant, silicone-coated top and waterproof-coated floor with overlapping closure/entry.
- **Includes:** Bivy, stuff sack.

<b>SIZE</b>	<b>One Size</b>
<b>SKU</b>	10852
<b>CAPACITY</b>	1
<b>WEIGHT</b>	MINIMUM: 180 g (6 oz) PACKAGED: 200 g (7 oz)
<b>INTERIOR PEAK HEIGHT</b>	
<b>POLES</b>	N/A
<b>RAINFLY FABRIC</b>	
<b>CANOPY FABRIC</b>	N/A
<b>FLOOR FABRIC</b>	15D ripstop nylon 1200mm Xtreme Shield™ polyurethane & DWR



Red

## Universal Footprint 1-Person

Easy, convenient protection for your tent floor.

- **Extend Tent Life:** Designed to keep your tent floor clean, dry and better protected from wear-and-tear.
- **Choose Your Size:** Comes in a variety of size options to fit MSR tents.

SIZE	Universal 1 Person Regular	Universal 1 Person Large
SKU	14099	14100
DIMENSIONS	71 x 211 cm (28 x 83 in)	81 x 211 cm (32 x 83 in)
WEIGHT	198 g (7 oz)	227 g (8 oz)



Red

## Universal Footprint 2-Person

Easy, convenient protection for your tent floor.

- **Extend Tent Life:** Designed to keep your tent floor clean, dry and better protected from wear-and-tear.
- **Choose Your Size:** Comes in a variety of size options to fit MSR tents.

SIZE	Universal 2 Person Regular	Universal 2 Person Large (PFAS)
SKU	14101	13011
DIMENSIONS	122 x 208 cm (48 x 82 in)	130 x 216 cm (51 x 85 in)
WEIGHT	227 g (8 oz)	255 g (9 oz)



Red

## Universal Footprint 3-Person

Easy, convenient protection for your tent floor.

- **Extend Tent Life:** Designed to keep your tent floor clean, dry and better protected from wear-and-tear.
- **Choose Your Size:** Comes in a variety of size options to fit MSR tents.

SIZE	Universal 3 Person Regular	Universal 3 Person Large (PFAS)
SKU	14103	13013
DIMENSIONS	160 x 208 cm (63 x 82 in)	175 x 211 cm (69 x 83 in)
WEIGHT	284 g (10 oz)	312 g (11 oz)



Red

## Universal Footprint 4-Person

Easy, convenient protection for your tent floor.

- **Extend Tent Life:** Designed to keep your tent floor clean, dry and better protected from wear-and-tear.
- **Choose Your Size:** Comes in a variety of size options to fit MSR tents.

SIZE	Universal 4 Person Regular
SKU	14115
DIMENSIONS	221 x 221 cm (87 x 87 in)
WEIGHT	369 g (13 oz)



Red

## Advance Pro™ Footprint

<b>SIZE</b>	<b>One Size</b>
<b>SKU</b>	14105
<b>DIMENSIONS</b>	102 x 211 cm (40 x 83 in)
<b>WEIGHT</b>	255 g (9 oz)



Gray

Red

## Tent Pole Repair Splints

**All-purpose tent pole repair splints.**

- 13 mm (0.51 in) fits most 1-3 person tents.
- 16 mm (0.63 in) fits most 2-4 person tents.
- Easily applied splint for field repairs.

<b>SIZE</b>	<b>13 mm</b>	<b>16 mm</b>
<b>SKU</b>	05826	05827
<b>DIMENSIONS</b>	1.3 x 13 x 1.3 cm (0.51 x 5 x 0.51 in)	1.6 x 13 x 1.6 cm (0.63 x 5 x 0.63 in)
<b>WEIGHT</b>	13 g (0.46 oz)	18 g (0.63 oz)



Red

## Adjustable Poles

**Ideal for tarp and wing shelters.**

- Collapsible, aircraft-grade aluminum pole design.
- 1.5 m (5 ft) pole adjusts from 140-167 cm (55-66 in).
- 2.4 m (8 ft) pole adjusts from 208-259 cm (82-102 in).

<b>SIZE</b>	<b>5 FT</b>	<b>4 ft</b>	<b>8 ft</b>
<b>SKU</b>	13311	05828	05830
<b>DIMENSIONS</b>	1.6 x 168 x 1.5 cm (0.625 x 66 x 0.625 in)	1.3 x 140 x 1.3 cm (0.5 x 55 x 0.5 in)	1.9 x 259 x 2 cm (0.75 x 102 x 0.75 in)
<b>WEIGHT</b>	278 g (9.8 oz)	190 g (6.7 oz)	624 g (22 oz)



Red

## Blizzard™ Tent Stakes

**Broad profile holds well in sand and snow.**

- 7000-series aluminum.
- Can be used as deadman anchor.
- 21 g (0.74 oz), 24 cm (9.5 in).

<b>SIZE</b>	<b>Bulk</b>	<b>Kit (4 Stakes)</b>
<b>SKU</b>	05810	05809
<b>DIMENSIONS</b>	1.27 x 24 x 3.8 cm (0.5 x 9.5 x 1.5 in)	
<b>WEIGHT</b>	21 g (0.74 oz)	84 g (3 oz)



Silver



Red

## Carbon-Core™ Tent Stakes

Our lightest full-strength, hard-ground tent stakes.

- Carbon fiber core with aluminum outer.
- Extremely durable head and aluminum tip.
- 5.75 g (0.2 oz), 15 cm (6 in).

SIZE	Kit (4 Stakes)
SKU	02499
DIMENSIONS	0.635 x 15 x 0.635 cm (0.25 x 6 x 0.25 in)
WEIGHT	23 g (0.8 oz)

## Cyclone™ Tent Stakes

Extra holding power in soft soil.

- 7000-series aluminum.
- Ideal for large tarps and wings.
- 35 g (1.2 oz), 25 cm (10 in).

SIZE	Kit (4 Stakes)
SKU	05806
DIMENSIONS	1.5 x 24 x 1.5 cm (0.6 x 9.5 x 0.6 in)
WEIGHT	140 g (4.8 oz)



Red



Red

## Groundhog™ Tent Stakes

Tent stake's y-beam design penetrates and holds.

- 7075-series aluminum.
- 13 g (0.46 oz), 19 cm (7.5 in).

SIZE	Bulk	Kit (6 Stakes)
SKU	05885	05807
DIMENSIONS	1.2 x 19 x 1.2 cm (0.47 x 7.5 x 0.47 in)	
WEIGHT	13 g (0.46 oz)	52 g (1.8 oz)

## Mini-Groundhog™ Tent Stakes

Lighter, best-selling version of the y-beam Groundhog stake.

- 7075-series aluminum.
- 10 g (0.35 oz), 15 cm (6 in).

SIZE	Bulk	Kit (6 Stakes)
SKU	06621	05808
DIMENSIONS	0.94 x 15 x 0.94 cm (0.37 x 6 x 0.37 in)	
WEIGHT	10 g (.35 oz)	60 g (2.1 oz)



Red



Gray

## Tent Guy Lines

**Lightweight and adjustable guy lines.**

- Secure, non-slip design.
- (4) Medium 2.4 m (8 ft) guy lines with CamRing™ Cord Tensioners.

SIZE	One Size
SKU	05820
DIMENSIONS	0.2 x 244 x 0.19 cm (0.078 x 96 x 0.078 in)
WEIGHT	6 g (0.21 oz)

## Stake Hammer

**Perfectly balanced for driving tent stakes.**

- Hardened stainless steel head.
- Comfortable shaft.
- Essential bottle opener.
- 312 g (11 oz).

SIZE	One Size
SKU	03074
DIMENSIONS	3.81 x 28 x 2.5 cm (1.5 x 11 x 1 in)
WEIGHT	312 g (11 oz)



Red/White



Red

## Night Glow Zipper Pulls

**Glowing zipper pulls offer easy tent access.**

- Glow-in-the-dark, glows for up to 8 hours.
- Easy to use with gloves.
- Reflective and lightweight.
- Quieter than metal pulls.

SIZE	One Size
SKU	05833
DIMENSIONS	1.27 x 7 x 1.5 cm (0.5 x 2.75 x 0.57 in)
WEIGHT	1 g (0.03 oz)

## Reflective Utility Cord Kit

**Reflective, knot-free cord kit.**

- 15 m (49.2 ft) of highly reflective 3 mm cord.
- 4 CamRing Cord Tensioners.

SIZE	One Size
SKU	05818
DIMENSIONS	0.3 x 1499 x 0.3 cm (0.12 x 590 x 0.12 in)
WEIGHT	91 g (3.2 oz)



Red/White

## Shock Cord Replacement Kit

### Premium silicone-core shock cords.

- Silicone core remains elastic to -20°F / -30°C.
- 9.1 m (30 ft) cord.
- Instructions included.

SIZE	One Size
SKU	05834
DIMENSIONS	0.38 x 914 x 0.4 cm (0.15 x 360 x 0.16 in)
WEIGHT	99 g (3.5 oz)



Red

## Ultralight Cord

### Lightweight, reflective, knot-free cord.

- 10 m (32 ft) of highly reflective 2.5 mm cord.
- 200-lb high tensile strength cord.

SIZE	One Size
SKU	05819
DIMENSIONS	0.25 x 975 x 0.25 cm (0.1 x 384 x 0.1 in)
WEIGHT	43 g (1.5 oz)



Red





## CamRing™ Cord Tensioners

### Ultralight knot-free tensioners for tent and tarp guy lines to make setup fast.

- Ultralight and easy-to-adjust ring design locks securely.
- Large rings fit 3- to 5-mm cord.
- **Includes:** (2) tensioners.

SIZE	One Size
SKU	05817
DIMENSIONS	3.6 x 4 x 1.3 cm (1.4 x 1.4 x 0.5 in)
WEIGHT	8 g (0.27 oz)

## MSR® SHELTER SPECIFICATIONS & COMPARISON

MSR® SHELTER SPECIFICATIONS & COMPARISON								
BIKEPACKING TENTS	SKU	CAPACITY	DOORS	MIN WEIGHT	PACKAGED WEIGHT	FLOOR + VESTIBULE	INTERIOR PEAK HEIGHT	PACKED SIZE
Hubba Hubba™ Bikepack 1	13706	1	1	0.93 kg (2 lb 1 oz)	1.27 kg (2 lb 13 oz)	1.67 + 0.82 sq m (18 + 9 sq ft)	0.97 m (38 in)	14 x 6.5 x 4.5 in (36 x 17 x 11 cm)
Hubba Hubba™ Bikepack 2	13707	2	2	1.40 kg (3 lb 1 oz)	1.71 kg (3 lb 12 oz)	2.7 + 1.63 sq m (29 + 17.5 sq ft)	1.07 m (42 in)	14.5 x 7 x 5 in (37 x 18 x 13 cm)
BACKPACKING TENTS	SKU	CAPACITY	DOORS	MIN WEIGHT	PACKAGED WEIGHT	FLOOR + VESTIBULE	INTERIOR PEAK HEIGHT	PACKED SIZE
Hubba Hubba™ LT 1	14306	1	1	1.07 kg (2 lb 6 oz)	1.23 kg (2 lb 11 oz)	1.82 + 0.74 sq m (20 + 8 sq ft)	0.99 m (39 in)	46 x 13 cm (18 x 5 in)
Hubba Hubba™ LT 2	14307	2	2	1.36 kg (3 lb)	1.54 kg (3 lb 6 oz)	2.95 + 1.48 sq m (32 + 16 sq ft)	1.02 m (40 in)	51 x 14 cm (20 x 5.5 in)
Hubba Hubba™ LT 3	14308	3	2	1.98 kg (4 lb 6 oz)	2.17 kg (4 lb 13 oz)	4.35 + 1.51 sq m (47 + 16 sq ft)	1.07 m (42 in)	51 x 17 cm (20 x 6.5 in)
Hubba Hubba™ HD 1	13939	1	1	1.20 kg (2 lb 10 oz)	1.36 kg (3 lb)	1.82 + 0.79 sq m (20 + 8.5 sq ft)	0.99 m (39 in)	51 x 13 cm (20 x 5 in)
Hubba Hubba™ HD 2	13940	2	2	1.61 kg (3 lb 9 oz)	1.80 kg (3 lb 15 oz)	2.95 + 1.53 sq m (32 + 16.5 sq ft)	1.02 m (40 in)	58 x 13 cm (23 x 5 in)
Hubba Hubba™ HD 3	13941	3	2	2.20 kg (4 lb 14 oz)	2.36 kg (5 lb 3 oz)	4.35 + 1.58 sq m (47 + 17 sq ft)	1.07 m (42 in)	58 x 13 cm (23 x 5 in)
FreeLite™ 1	 14147 11511	1	1	0.74 kg (1 lb 10 oz)	0.89 kg (1 lb 15 oz)	1.85 + 0.74 sq m (20 + 8 sq ft)	1.00 m (39 in)	46 x 10 cm (18 x 4 in)
FreeLite™ 2	 14148 11512	2	2	0.91 kg (2 lb)	1.06 kg (2 lb 5 oz)	2.70 + 1.40 sq m (29 + 15 sq ft)	1.00 m (39 in)	46 x 11 cm (18 x 4.5 in)
FreeLite™ 3	 14149 11513	3	2	1.07 kg (2 lb 6 oz)	1.23 kg (2 lb 11 oz)	3.57 + 1.40 sq m (38.5 + 14 sq ft)	1.09 m (43 in)	48 x 13 cm (19 x 5 in)
Tindheim™ 2	10832	2	1	2.48 kg (5 lb 7 oz)	3.20 kg (7 lb 1 oz)	3.11 + 1.49 sq m (33.5 + 16 sq ft)	1.01 m (40 in)	56 x 20 cm (22 x 8 in)
Tindheim™ 3	10833	3	1	2.91 kg (6 lb 7 oz)	3.73 kg (8 lb 4 oz)	3.67 + 1.76 sq m (39.5 + 19 sq ft)	1.09 m (43 in)	58 x 20 cm (23 x 8 in)
Elixir™ 1	13698	1	1	1.84 kg (4 lb 1 oz)	2.33 kg (5 lb 2 oz)	1.70 + 0.74 sq m (18 + 8 sq ft)	0.99 m (39 in)	48 x 13 cm (19 x 5.5 in)
Elixir™ 2	13699	2	2	2.33 kg (5 lb 2 oz)	2.82 kg (6 lb 3 oz)	2.82 + 1.41 sq m (30 + 15 sq ft)	1.04 m (41 in)	51 x 17 cm (20 x 6.5 in)
Elixir™ 3	13700	3	2	2.75 kg (6 lb 1 oz)	3.24 kg (7 lb 2 oz)	3.79 + 1.41 sq m (41 + 15 sq ft)	1.09 m (43 in)	53 x 19 cm (21 x 7.5 in)
Elixir™ 4	13701	4	2	3.72 kg (8 lb 3 oz)	4.21 kg (9 lb 4 oz)	5.11 + 1.51 sq m (55 + 16 sq ft)	1.22 m (48 in)	56 x 19 cm (22 x 7.5 in)
Gear Shed	 10334 10314	GEAR		0.82 kg (1 lb 13 oz)	0.94 kg (2 lb 1 oz)	2.46 sq m (26.5 sq ft)	0.89 m (35 in)	48 x 11 cm (19 x 4.5 in)
TARPS, BIVIES & SHELTERS	SKU	CAP.	DOORS	MIN WEIGHT	PACKAGED WEIGHT	FLOOR + VESTIBULE	INTERIOR PEAK HEIGHT	PACKED SIZE
Thru-Hiker 70 Wing	10827	2-3		0.38 kg (12 oz)	0.46 kg (1 lb)	6.50 sq m (70 sq ft)	Variable	23 x 10 cm (9 x 4 in)
Thru-Hiker 100 Wing	10828	2-3		0.49 kg (1 lb 1 oz)	0.57 kg (1 lb 4 oz)	9.29 sq m (100 sq ft)	Variable	23 x 10 cm (9 x 4 in)
E-Bivy™	10852	1		0.18 kg (6 oz)	0.20 kg (7 oz)			18 x 10 cm (7 x 4 in)

## MSR® SHELTER SPECIFICATIONS & COMPARISON

ALL-SEASON TENTS	SKU	CAP.	DOORS	MIN WEIGHT	PACKAGED WEIGHT	FLOOR + VESTIBULE	INTERIOR PEAK HEIGHT	PACKED SIZE
<b>Access™ 1</b>	13131	1	1	1.37 kg (3 lb)	1.60 kg (3 lb 8 oz)	1.76 + 0.23 sq m (19 + 9 sq ft)	1.01 m (40 in)	46 x 15 cm (18 x 6 in)
	13116							
<b>Access™ 2</b>	13132	2	2	1.64 kg (3 lb 10 oz)	1.86 kg (4 lb 1 oz)	2.69 + 1.62 sq m (29 + 17.5 sq ft)	1.07 m (42 in)	46 x 15 cm (18 x 6 in)
	13117							
<b>Access™ 3</b>	13133	3	2	1.99 kg (4 lb 6 oz)	2.3 kg (5 lb 1 oz)	3.8 + 1.62 sq m (41 + 17.5 sq ft)	1.19 m (47 in)	53 x 17 cm (21 x 7 in)
	13118							
<b>Remote™ 2</b>	13113	2	2	3.02 kg (6 lb 11 oz)	3.23 kg (7 lb 2 oz)	3.06 + 2.04 sq m (33 + 22 sq ft)	1.12 m (44 in)	51 x 17 cm (20 x 7 in)
<b>Remote™ 3</b>	13114	3	2	3.69 kg (8 lb 2 oz)	3.99 kg (8 lb 13 oz)	4.3 + 2.04 sq m (46 + 22 sq ft)	1.12 m (44 in)	51 x 20 cm (20 x 8 in)
<b>Advance Pro™ 2</b>	13110	2	1	1.30 kg (2 lb 14 oz)	1.46 kg (3 lb 3 oz)	2.23 sq m (24 sq ft)	1.12 m (44 in)	46 x 15 cm (18 x 6 in)
<b>Front Range™ Ultralight Tarp Shelter</b>	13113	4	1	0.74 kg (1 lb 10 oz)	0.91 kg (2 lb)	7.52 sq m (81 sq ft)	1.62 m (64 in)	30 x 13 cm (12 x 5 in)
	14113							
<b>Front Range™ Bug/Floor Insert</b>	13120	4	1	0.88 kg (1 lb 15 oz)	1.04 kg (2 lb 5 oz)	4.97 sq m (53.5 sq ft)	1.42 m (56 in)	30 x 13 cm (12 x 5 in)
<b>Pro Bivy</b>	10830	1		0.28 kg (10 oz)	0.34 kg (12 oz)			20 x 10 cm (8 x 4 in)





## WHY CHOOSE A PURIFIER? **MAXIMUM PROTECTION**

As more people visit popular wilderness sites, the risk of viruses increases. Since viruses are too small for microfilters to catch, a quality purifier provides adventurers with a reliable defense. In fact, our most advanced purifiers combat viruses, bacteria and protozoa, sediment, taste and odors, delivering one ultimate tool to do it all.

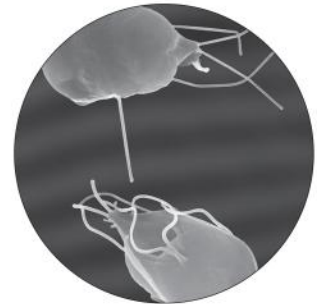

## OUR WORLD-CLASS **RESEARCH, DESIGN & TESTING**

Our on-site water lab is staffed with scientists who individually test our devices to ensure greater safety and ease of use.

### Every MSR hollow fiber filter and purifier features:

- **A unique integrity check** that allows the user to easily confirm that, if the device is dropped or frozen, the fibers haven't been damaged and the device is working safely.
- **An end-of-life indicator** stops the filter media from passing water. This clearly identifies that it's time to replace the cartridge without exposing the user to harmful pathogens.
- **Passes NSF Protocol P231** throughout the filter's life. The test confirms microbiological threat removal from a variety of water types, unlike NSF 42 and 53, which aren't suitable tests for backcountry use.



## NSF PROTOCOL P231 & P248 **TESTING STANDARDS**

Though backcountry water filters and purifiers are unregulated, NSF Protocol P231 and P248 provide scientifically accepted standards for testing them. Every MSR design passes a stringent test when challenged with what's considered worst-case water (extreme levels of microbes, turbidity, etc.)—even at the end of its life. These standards are the best way to prove a device offers protection against real backcountry water types throughout its useful life.



# 2026 WATER TREATMENT | LINE PLAN

€€€



€



**GUARDIAN™ PURIFIER**  
**VIRUS PROTECTION**



**GUARDIAN™ GRAVITY PURIFIER**  
**VIRUS PROTECTION**



**HYPERFLOW™ MICROFILTER**



**AUTOFLOW™ XL GRAVITY FILTER 10L**



**TRAILSHOT™ MICROFILTER**



**MINIWORKS™ EX MICROFILTER**



**THRU-LINK™ INLINE MICROFILTER**

**PERSONAL**

**PUMPS**

**GROUP / GRAVITY**



Multi



Multi

## Guardian™ Gravity Purifier

State-of-the-art, high-volume water purifier – the only gravity system you may ever need.

- **Ultimate Two-Stage Protection:** Hollow fiber removes viruses, protozoa, bacteria and microplastics; activated carbon reduces chemicals, tastes and odors.
- **Easy to Fill:** 10L reservoir fills easily at sinks and wild sources. Universal bottle adapter prevents cross-contamination.
- **High-Flow Cartridge:** Advanced engineering creates fast virus-removing gravity system (1L in 2 min).
- **No Backflushing:** Restore flow by simply opening the purge hose to flush and clean the system.
- **Built for Travel:** Rugged, military-grade construction; fits easily in carry-on.

SIZE	One Size
SKU	14005
DIMENSIONS	10 x 30 x 10 cm (3.9 x 12 x 4 in)
WEIGHT	530 g (18.7 oz)
FILTER MEDIA	Advanced Hollow Fiber
FILTER PORE SIZE	0.02
FLOW RATE	0.5 L/min
CARTRIDGE LIFE	3000+ L

## Guardian™ Purifier Pump

The world's most advanced backcountry purifier.

- **Ultimate Protection:** Meets NSF protocol P248 testing standard used by U.S. military for removing viruses, protozoa, bacteria and sediment.
- **Self-Cleaning:** Patent-pending system self-cleans with each stroke, eliminating the need to ever backflush or filter-scrub to maintain flow.
- **Fast, Easy & Long-Lasting:** Purifies 2.5 liters per minute from nearly any source and treats up to 10,000 liters.
- **Rugged Construction:** Stands up to heavy use and extreme environments; hollow fibers withstand freezing.

SIZE	One Size (PFAS)
SKU	02370
DIMENSIONS	7.6 x 21 x 11.4 cm (3 x 8.25 x 4.5 in)
WEIGHT	490 g (17.3 oz)
FILTER MEDIA	Advanced Hollow Fiber
FILTER PORE SIZE	0.02
FLOW RATE	2.5 L/min
CARTRIDGE LIFE	10,000+ L



Gray

## Thru-Link™ Inline Microfilter

**Inline ease and efficiency for big days, with fast filtering on the go.**

- **Two-Stage Filtration:** Fast-flow hollow fiber removes pathogens, particulate & microplastics; activated carbon reduces chemicals, tastes and odors.
- **Fast:** Engineered specifically for inline filtration and high-flow drinking.
- **Universal Fit:** Quick-connects into any hydration reservoir.
- **Proven:** Used by the U.S. military for more than a decade.
- **Safe:** Rugged ultrasonic-welded ABS housing. Meets NSF protocol P231 for removal of bacteria and protozoa.

SIZE	One Size
SKU	13236
DIMENSIONS	4.2 x 19 x 4.2 cm (1.6 x 7.5 x 1.6 in)
WEIGHT	71 g (2.5 oz)
FILTER MEDIA	Hollow Fiber
FILTER PORE SIZE	0.2
FLOW RATE	1.5 L/min
CARTRIDGE LIFE	1000 L



Multi



## TrailShot™ Microfilter

**So small there's no excuse to leave it behind on fast-paced, all-day adventures.**

- **Pocket-Sized & Light:** 142 g (5 oz) microfilter stashes in a pocket.
- **Drink from the Source:** Drink directly from water sources along the trail and refill multiple vessels.
- **Fast & Easy:** Quick-deploy design & simple squeezing action fills 1-liter bottles in 60 seconds.
- **Safe:** Hollow fiber filter meets NSF protocol P231 for removal of protozoa and bacteria. Treats up to 2,000 liters.

SIZE	One Size
SKU	09385
DIMENSIONS	6.1 x 15.25 x 16 cm (2.4 x 6 x 6 in)
WEIGHT	140 g (5 oz)
FILTER MEDIA	Hollow Fiber
FILTER PORE SIZE	0.2
FLOW RATE	1 L/min
CARTRIDGE LIFE	2000 L



Red

## HyperFlow™ Microfilter

**Our fastest compact pump microfilter.**

- **Super-Fast:** Pumps up to 3 liters per minute.
- **Ultralight:** Just 221 g (7.8 oz).
- **Field-Maintainable:** Can be cleaned repeatedly for flow recovery; no tools required for complete disassembly.
- **Adaptable:** Connects directly to Dromedary® and DromLite™ bags, Hydromedary™ hydration systems and standard wide-mouth bottles.
- **Safe:** Hollow fiber filter meets NSF protocol P231 for removal of bacteria and protozoa.

SIZE	One Size
SKU	14008
DIMENSIONS	8.3 x 18 x 76 cm (3.2 x 7 x 3 in)
WEIGHT	221 g (7.8 oz)
FILTER MEDIA	Hollow Fiber
FILTER PORE SIZE	0.2
FLOW RATE	3 L/min
CARTRIDGE LIFE	1000 L



Multi

## MiniWorks® EX Microfilter

**Durable microfilter for day hikes and expeditions. An MSR best seller for over 20 years.**

- **Long-lasting:** Durable ceramic element filters up to 2,000 liters.
- **Solid Activated Carbon Core:** Reduces unpleasant tastes and odors, along with many chemical contaminants.
- **Field-Maintainable:** Can be cleaned repeatedly for full flow recovery; no tools required for complete disassembly.
- **Easy-to-Use:** Attaches to Dromedary® bags and wide-mouth bottles.
- **Safe:** Meets NSF protocol P231 for removal of bacteria and protozoa.

SIZE	One Size
SKU	14006
DIMENSIONS	7 x 19 x 14 cm (2.7 x 7.5 x 5.5 in)
WEIGHT	456 g (16 oz)
FILTER MEDIA	Ceramic Plus Carbon
FILTER PORE SIZE	0.2
FLOW RATE	1 L/min
CARTRIDGE LIFE	2000 L



Black



Gray

## AutoFlow™ XL Gravity Filter 10L

Fast, high-volume hollow fiber water filtration for groups and basecamps.

- **Fast:** Uses gravity to filter 1.75 liters per minute, letting you multitask at camp.
- **Rugged:** Durable film reservoir with RF-welded seams.
- **Field-Maintainable:** Filter is easily cleaned in the field; no tools required.
- **Safe:** Meets NSF protocol P231 for removal of bacteria and protozoa.

SIZE	One Size
SKU	14004
DIMENSIONS	4 x 12.5 x 76 cm (1.6 x 11 x 3 in)
WEIGHT	340 g (12 oz)
FILTER MEDIA	Hollow Fiber
FILTER PORE SIZE	0.2
FLOW RATE	1.75 L/min
CARTRIDGE LIFE	1500 L

## DromLite™ Bags

Supremely packable water storage bags with the weight savings to match.

- **Extremely Compact:** High-capacity bag folds down to size of its cap for discreet storage.
- **Light:** Lightweight, durable film construction is perfect for fast-and-light travel.
- **Convenient Attachment:** Makes it easy to hang from packs or trees; set up as a basecamp reservoir or shower station.
- **Durable:** Made with rugged film and RF-welded seams.
- **Safe Drinking:** BPA-free.

SIZE	2 L	4 L	6 L
SKU	09583	09584	09585
DIMENSIONS	21.6 x 39.6 x 5 cm (8.5 x 15.6 x 2 in)	25.4 x 46.5 x 5 cm (10 x 18.3 x 2 in)	28.7 x 52.3 x 5 cm (11.3 x 20.6 x 2 in)
WEIGHT	130 g (4.6 oz)	145 g (5.1 oz)	162 g (5.7 oz)



Black

## Dromedary® Bags

The world's burliest solution to collapsible backcountry water storage.

- **Heavy-Duty:** Abrasion-resistant, hydrophobic 1000D fabric withstands freezing, boiling, and the abuse of expedition crews and hardcore adventurers.
- **Food-grade Lining:** Ensures better tasting water.
- **Redesigned Cap:** Low-profile 3-in-1 cap lets you fill, drink and pour with ease.
- **Convenient Attachment:** Streamlined webbing and strategic grommets for pack attachment and hanging.
- **Safe Drinking:** BPA-free.

SIZE	4 L	6 L	10 L
SKU	09586	09587	09588
DIMENSIONS	25.4 x 46.5 x 5 cm (10 x 18.3 x 2 in)	28.7 x 52.3 x 5 cm (11.3 x 20.6 x 2 in)	31.75 x 58.4 x 5 cm (12.5 x 23 x 2 in)
WEIGHT	196 g (6.9 oz)	247 g (8.7 oz)	284 g (10 oz)



Gray

## Guardian™ Gravity Replacement Cartridge

Replacement cartridge with hollow-fiber technology and activated carbon.

SIZE	One Size
SKU	13469
DIMENSIONS	3.8 x 25 x 5 cm (1.5 x 10 x 2 in)
WEIGHT	133 g (4.7 oz)



Red

## Guardian™ Purifier Replacement Cartridge

Replacement hollow fiber cartridge. Comes with clean-side cover.

SIZE	One Size
SKU	02407
DIMENSIONS	7 x 14.5 x 7 cm (2.7 x 5.75 x 2.75 in)
WEIGHT	175 g (6 oz)



Black

## AutoFlow™ Replacement Cartridge

Replacement hollow fiber filter cartridge.

SIZE	One Size
SKU	06201
DIMENSIONS	5 x 15 x 5 cm (2 x 6 x 2 in)
WEIGHT	57 g (2 oz)



Red

## TrailShot™ / Trail Base™ Replacement Filter Cartridge & Maintenance Kit

Replacement cartridge and maintenance kit for the TrailShot/Trail Base filter.

- **Includes:** Replacement TrailShot filter cartridge, umbrella valve, check valve, prefilter, food-grade silicone lubricant, instructions.

SIZE	One Size
SKU	09592
DIMENSIONS	2.5 x 8.9 x 2.5 cm (1 x 3.5 x 1 in)
WEIGHT	31 g (1.1 oz)



NA

## Guardian™ Purifier Maintenance Kit

A complete maintenance kit for the Guardian Purifier. Ensures years of lasting and reliable performance.

- **Includes:** Instructions, pressure relief valve assembly, O-rings, cup seal, piston, umbrella valve, silicone lubricant, Cleanside cover.

SIZE	One Size
SKU	02405
DIMENSIONS	4.5 x 8 x 4.6 cm (1.8 x 3.3 x 1.8 in)
WEIGHT	31 g (1.1 oz)



Red

## HyperFlow™ Microfilter Maintenance Kit

A complete maintenance kit for the HyperFlow Microfilter pump.

- **Includes:** Instructions, small check valve, large check valve, replacement piston O-ring, replacement quick-connect bottle adapter O-ring, O-ring installation tool, O-ring removal tool (jet and cable tool), silicone lubricant.

SIZE	One Size
SKU	56508
DIMENSIONS	4.0 x 11.3 x 4.2 cm (1.6 x 4.4 x 1.6 in)
WEIGHT	45 g (6 oz)



Black

## HyperFlow™ Microfilter Cartridge Replacement

Refresh flow rates with a new hollow fiber filter cartridge.

SIZE	One Size
SKU	56506
DIMENSIONS	2.5 x 12.5 x 2.5 cm (1 x 4.9 x 1 in)
WEIGHT	23 g (0.8 oz)



Multi

## MiniWorks® / WaterWorks® Ceramic Element

Replacement element provides increased flow rate for older models.

SIZE	One Size
SKU	56453
DIMENSIONS	5 x 11.7 x 5 cm (2 x 4.6 x 2 in)
WEIGHT	107 g (3.8 oz)



Red



Black

## MiniWorks® / WaterWorks® Maintenance Kit

A complete maintenance kit for both the MiniWorks and WaterWorks microfilters.

- **Includes:** Instructions, O-ring for lower end-cap, O-ring for filter housing, inlet filter, silicone lubricant for O-rings, O-ring for relief valve, O-rings for piston, duck bill valve, washer, umbrella valve.

SIZE	One Size
SKU	56002
DIMENSIONS	4.5 x 8 x 2.5 cm (1.8 x 3.3 x 1 in)
WEIGHT	31 g (1.1 oz)

## 3-in-1 Hydration Cap

Low-profile 3-in-1 cap for Dromedary® and DromLite™ bags lets you fill, drink and pour with greater ease.

SIZE	One Size
SKU	09589
DIMENSIONS	7.6 x 7.6 x 3.8 cm (3 x 3 x 1.5 in)
WEIGHT	23.6 g (0.8 oz)

## MSR® WATER TREATMENT SPECIFICATIONS

Model	Guardian™ Gravity Purifier	Guardian™ Purifier	MiniWorks® EX	Thru-Link™	TrailShot™ Microfilter	HyperFlow™ Microfilter	AutoFlow™ XL Gravity Filter 10L
SKU	14005	02370	14006	13236	09385	14008	14004
PHYSICAL SPECS							
Weight	532 g (18.7 oz)	490 g (17.3 oz)	456 g (16 oz)	71 g (2.5 oz)	142 g (5 oz)	221 g (7.8 oz)	340 g (12 oz)
Dimensions	32 x 12 cm (12.5 x 4.7 in)	21 x 11 cm (8.2 x 4.4 in)	19 x 7 cm (7.5 x 2.75 in)	4.1 x 19 cm (1.6 x 7.5 in)	15.25 x 6.1 cm (6 x 2.4 in)	17.8 x 8.3 cm (7 x 3.5 in)	30.5 x 12.7 cm (12 x 5 in)
Filter Matrix	Hollow Fiber	Hollow Fiber	Ceramic	Hollow Fiber	Hollow Fiber	Hollow Fiber	Hollow Fiber
Filter Pore Size	0.02 Micron	0.02 Micron	0.2 Micron	0.2 Micron	0.2 Micron	0.2 Micron	0.2 Micron
EFFECTIVE AGAINST							
Protozoa	✓	✓	✓	✓	✓	✓	✓
Bacteria	✓	✓	✓	✓	✓	✓	✓
Viruses	✓	✓	NO	NO	NO	NO	NO
Particulate	✓	✓	✓	✓	✓	✓	✓
Taste/Odor	✓	NO	✓	✓	NO	NO	NO
PERFORMANCE							
Flow (liters per minute)	0.45 Liter per Minute	2.5 Liters per Minute	1 Liter per Minute	1.2 Liter per Minute	1 Liter per Minute	3 Liters per Minute	1.75 Liter per Minute
Flow (strokes per liter)	N/A	30-35	80-90	N/A	N/A	20	N/A
Cartridge Life	3000+ Liters	10,000+ Liters	2000 Liters	1000 Liters	2000 Liters	1000 Liters	1500 Liters
Field Cleanable	Purge Valve	Self-Cleaning	✓	✓	✓	✓	✓
Field Maintainable	N/A	✓	✓	N/A	✓	✓	✓
EXTRAS/FEATURES							
Pump	NO	✓	✓	NO	✓	✓	NO
Gravity	✓	NO	NO	✓	NO	NO	✓
Water Bottle Adapter	✓	✓	✓	NO	NO	✓	✓
End of Life Indicator	✓	✓	✓	✓	✓	✓	✓

## MSR® DROMEDARY BAGS SPECIFICATIONS

DROMLITE™ BAGS	VOLUME	SKU	WEIGHT	DIMENSIONS
	2 Liters	09583	130 g (4.6 oz)	22 x 40 cm (8.5 x 15.6 in)
	4 Liters	09584	145 g (5.1 oz)	25.4 x 46.5 cm (10 x 18.3 in)
	6 Liters	09585	162 g (5.7 oz)	28.7 x 52.3 cm (11.3 x 20.6 in)
DROMEDARY® BAGS	VOLUME	SKU	WEIGHT	DIMENSIONS
	4 Liters	09586	196 g (6.9 oz)	25.4 x 46.5 cm (10 x 18.3 in)
	6 Liters	09587	247 g (8.7 oz)	28.7 x 52.3 cm (11.3 x 20.6 in)
	10 Liters	09588	284 g (10 oz)	31.8 x 58.4 cm (12.5 x 23 in)



# REAL-WORLD PERFORMANCE— IT'S WHAT FUELS US



# STOVE TECH: A LEGACY OF INNOVATION

Every MSR® stove ever built has come to fruition with a singular purpose—to solve real world problems. Our forward-thinking innovations have led the industry and broken down barriers to what could be accomplished outdoors. Whether your goal is reaching the world's farthest corners or laying out a feast for friends on a weekend close to home, you can trust MSR to lead the way.

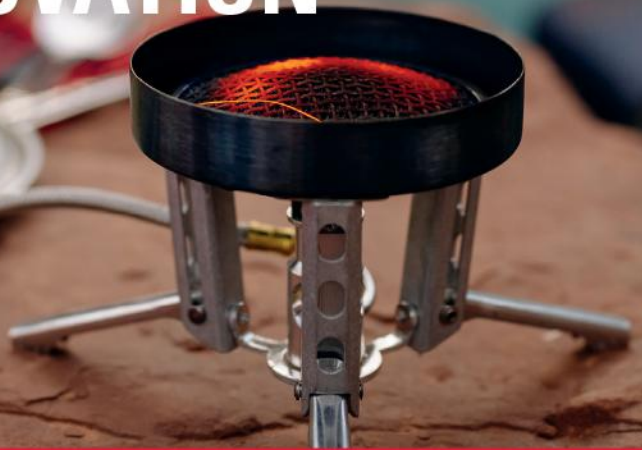

## **Problem:** High Altitude Dehydration

### **MSR Innovation:** Remote Burner Stoves

Introduced in 1973, the Model 9 stove was the first to separate burner and fuel source, allowing the use of a windscreen to significantly boost all-condition performance. In addition, the remotely pressurized fuel tank, crude, multi-fuel capabilities and a myriad of overall design improvements boosted function and efficiency far beyond anything else available. It remains the basis of all liquid fuel designs to this day.

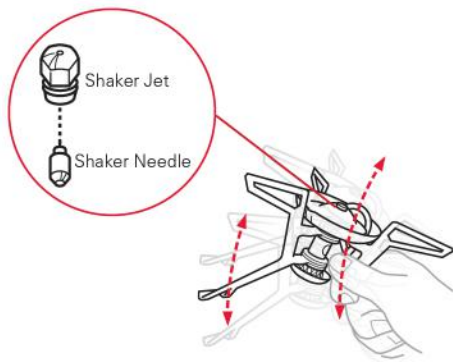
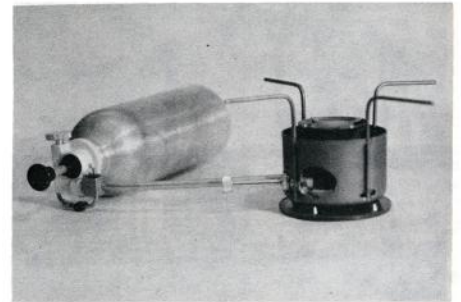

## **Problem:** Fuel Availability/Clogged Stoves

### **MSR Innovation:** Fuel-Specific Shaker Jets

The jet, where pressurized fuel escapes the stove to create a flame, was the Achilles heel of early liquid fuel stoves, especially with unpredictable international fuel sources. Our two-fold solution began with the first field-replaceable jets, sized to match the viscosity and carbon-collecting tendencies of fuels ranging from highly refined white gas to rough-burning diesel fuels. Adding a floating pin inside the jet came next, allowing the stove's jet to be purged of obstructions with a simple shake.

## **Problem:** Reliability

### **MSR Innovation:** Field-Serviceable Stoves

Reliability is the cornerstone of every MSR product, but we also know that people lean hard on our gear in remote places. If something breaks north of the Arctic Circle, it needs to get fixed. That's why we've engineered our liquid-fuel stoves to be virtually resurrect-able from the ground up, with a simple, all-in-one tool and a basic maintenance kit. From cleaning a fuel line in the field to a complete refurbishment on the workbench at home, MSR stoves are built like no others, for generations of reliable performance.



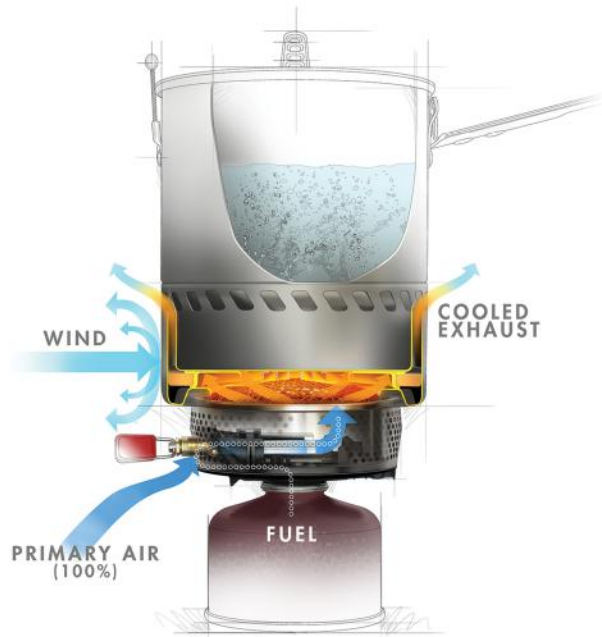

**Problem:** Stove Efficiency in Windy Conditions

**MSR Innovation:** Primary Air Combustion

We didn't invent primary air combustion, but we were first to bring it into the backcountry. Typical combustion requires oxygen (secondary air) around and above the flame, as well as from below (primary air). 100% primary air combustion draws all the air needed from below, allowing a completely enclosed flame, significantly boosting the efficiency of combustion. The clear benefits of needing less fuel overall are amplified by the all-condition reliability of a flame impervious to wind, making our Reactor® and WindBurner® stove systems unrivaled in real-world performance.

**Problem:** Excess Fuel Demands/Heavy Packs

**MSR Innovation:** Hyper-Efficient Cookware

The efficiency of MSR stove systems would not be possible without cookware engineered to make the most of it. Fully enclosing the burner, our advanced Reactor and WindBurner cook pots are built to not only block wind, but also to maximize heat transfer by trapping hot combustion gases around the pot for longer, and boosting the surface area where that transfer takes place. Like the rest of our cookware, we do it all with the best materials for the job at hand to ensure you can tune your kit to the priorities of any trip.



**Problem:** Consistent Canister Performance

**MSR Innovation:** Pressure-Regulated Stoves

Canister stoves rely on the low boiling point of fuel to generate pressure through vaporization inside of the canister. However, internal canister pressure can range from 70 psi in summer to just a few psi in cold temps, with low fuel levels, or during long stove runs. We've optimized our pressure-regulated stoves to operate optimally at low pressures, assuring consistent performance in the widest range of temperatures possible and minimizing wasted fuel.

# 2026 STOVES | LINE PLAN

€€€



REACTOR® 1.0 L  
STOVE SYSTEM



REACTOR® 1.7 L  
STOVE SYSTEM



REACTOR® 2.5 L  
STOVE SYSTEM



WINDBURNER®  
DUO STOVE SYSTEM



WINDBURNER® PERSONAL  
STOVE SYSTEM



XGK™ EX



SWITCH™  
STOVE SYSTEM



POCKETROCKET®  
STOVE KIT



POCKETROCKET® 2



POCKETROCKET® 2  
MINI STOVE KIT

€

BOIL

# 2026 STOVES | LINE PLAN

€€€



**WINDBURNER®  
STOVE SYSTEM  
COMBO**



**WINDBURNER® GROUP  
STOVE SYSTEM**



**WHISPERLITE™  
UNIVERSAL**



**WHISPERLITE™  
INTERNATIONAL**



**POCKETROCKET®  
DELUXE STOVE KIT**



**POCKETROCKET®  
DELUXE**



**DRAGONFLY®**



**WINDPRO™ II**

€

**COOK**

**SIMMER**

# SWITCH™ STOVE SYSTEM

## THE STOVE FOR EVERYONE

The versatility of the Switch stove comes from the unique hemispherical pot and the multi-functional pot supports.



With a simple flip of the pot supports, this solo cook system instantly becomes an adaptable stove that can serve more campers or become a gourmet chef's backcountry kitchen; no accessories needed. In non-system pot mode, the Switch can accommodate a variety of cookware from larger pots that boil pasta to non-stick skillets for your morning eggs.

## PRESSURE-REGULATED PERFORMANCE

Very few stoves in this class include a pressure regulator, making the Switch the most reliable performance option for beginner to intermediate adventurers. The pressure regulator provides consistent output in colder temperatures and at altitude where the competition struggles, for true three-season performance. It also maximizes fuel efficiency, so users get the most out of each canister.



In 'system mode', the ring stand supports the Switch pot. Its patent-pending hemispherical bottom is wrapped evenly by the flame, heating quickly and evenly without a heat exchanger. As an everything-included solo system with a built-in piezo ignitor and cup, it's lightweight and compact.



## PREMIUM CORK

The premium, removable cork cozy is a more sustainable option with many performance benefits. The cork is burn resistant and won't melt upon accidental contact with heat. It also provides better grip when wet than other materials, minimizing the chance for spills.





Multi



Black



## Switch™ Stove System

The most versatile, high-performance system stove in its class.

- **Versatile:** Flip-out pot supports allow users to use the integrated Switch pot or bring their preferred pot (not to exceed 8 in / 20.3 cm diameter; 5 in / 12.7 cm height, 8 lb / 3.6 kg weight).
- **High-performance:** The pressure regulator provides good fuel efficiency, even in cold conditions and higher altitudes, and improves flame control for more precision cooking.
- **Hemispherical Pot:** Patent-pending round-bottom Switch pot heats faster and more evenly than conventional flat-bottom pots.
- **Stable Pot Support:** Ring stand for integrated pot to rest on makes placing the pot on the stove easy and intuitive.
- **Easy to Light:** Built-in piezo ignitor makes lighting the stove simple and fast.
- **Includes:** Switch™ stove; Switch™ pot with lid\* and cork cozy; plastic nesting bowl\*; canister stand; and PackTowl® cleaning cloth. Room to nest a 4 oz (110 g) IsoPro fuel canister. \*BPA-free.

SIZE	One Size
SKU	13844
DIMENSIONS	12.12 x 11.3 x 18 cm (4.8 x 4.5 x 7.1 in)
WEIGHT	MINIMUM: 117 g (4.1 oz) PACKAGED: 13.8 g (13.8 oz)
BOIL TIME (1 L WATER)	5 min
WATER BOILED (PER 8 OZ CANISTER)	14.8 L
BURN TIME	84.5 min

## PocketRocket® Deluxe Stove

Ultralight and fully featured for a consistently fast and excellent cooking experience.

- **Pressure Regulator:** Maintains stove's fast boil times even in cold weather and with low fuel.
- **Push-start Ignition:** Fast, reliable piezo lighting; spark igniter is protected inside burner head for maximum durability.
- **Ultralight & Fast:** Just 83 g (2.9 oz); boils 1 liter of water in 3:20 minutes.
- **Broad Burner:** Improves wind resistance and combines with simmer control for excellent cooking versatility.

SIZE	One Size
SKU	10955
DIMENSIONS	5.6 x 3.8 x 8.4 cm (2.2 x 1.5 x 3.3 in)
WEIGHT	MINIMUM: 83 g (2.9 oz) PACKAGED: 97 g (3.4 oz)
BOIL TIME (1 L WATER)	3.3 min
WATER BOILED (PER 8 OZ CANISTER)	17 L
BURN TIME	60 min



Steel

## LowDown™ Remote Stove Adapter

**More stability, more versatility for canister stoves.**

- **Stable:** Low center of gravity; use large pots and cook on uneven ground with confidence.
- **Remote Control:** Off-stove flame control keeps hands away from burner and hot cookware.
- **Universal:** Works with all current MSR canister-mounted stoves and stove systems.
- **Packable:** Compact, folding design weighs just 176 g (6.2 oz).

<b>SIZE</b>	<b>One Size</b>
<b>SKU</b>	11582
<b>DIMENSIONS</b>	3.6 x 13.0 x 4.3 cm (1.4 x 5.1 x 1.7 in)
<b>WEIGHT</b>	176 g (6.2 oz)



Black

## PocketRocket® 2 Stove

Our lightest and most compact, fast-boiling stove for serious gram-counters.

- **Ultralight:** At just 73 g (2.6 oz), this easy-to-use stove keeps pack weight to the absolute minimum.
- **Ultra-compact:** Folding pot supports pack exceptionally small; stove with case fits inside MSR Titan™ Cup.
- **Fast:** Boils 1 liter of water in just 3.5 minutes.
- **Strong:** Robust pot supports accommodate a wide range of pot sizes.
- **Includes:** Ultralight hard-shell carry case.

SIZE	One Size
SKU	09884
DIMENSIONS	4.3 x 3.3 x 7.9 cm (1.7 x 1.3 x 3.1 in)
WEIGHT	MINIMUM: 73 g (2.6 oz) PACKAGED: 105 g (3.7 oz)
BOIL TIME (1 L WATER)	3.5 min
WATER BOILED (PER 8 OZ CANISTER)	16 L
BURN TIME	60 min



Steel

## WindPro™ II Stove

Excellent remote-canister stability for ultra-efficient cold weather performance.

- **Inverted Liquid-feed:** Inverting canister allows stove to run on liquid fuel for increased cold-weather and low-fuel performance.
- **Remote Burner:** Added stability for use with large pots (up to 10" diameter).
- **Compatible:** Design allows the use of a windscreen; compatible with bake ovens.
- **Lightweight:** Weighs just 187 g (6.6 oz).

SIZE	One Size
SKU	14046
DIMENSIONS	10.2 x 7.6 x 15 cm (4 x 3 x 6 in)
WEIGHT	MINIMUM: 187 g (6.6 oz) PACKAGED: 292 g (10.3 oz)
BOIL TIME (1 L WATER)	3.6 min
WATER BOILED (PER 8 OZ CANISTER)	15 L
BURN TIME	70 min



Multi



Multi



## PocketRocket® Stove Kit

Complete cook-and-eat kit for two, featuring the original, iconic PocketRocket stove.

- **Fast:** Original PocketRocket stove boils 1 liter in 3.5 minutes.
- **Lightweight:** Whole kit weighs only 732 g (25.8 oz), making it great for backpacking.
- **Compact:** Nested design packs easily and discreetly.
- **Includes:** PocketRocket stove, 2.0L hard-anodized aluminum pot, (2) DeepDish™ bowls\*, (2) 12.5 oz double-wall insulated mugs\*, clear strainer lid\*, (2) folding sporks\*.
- \*BPA-free.

SIZE	One Size
SKU	14272
DIMENSIONS	15.3 x 14.5 x 14.5 cm (6 x 5.7 x 5.7 in)
WEIGHT	732 g (25.8 oz)
BOIL TIME (1 L WATER)	3.5 min
WATER BOILED (PER 8 OZ CANISTER)	16 L
BURN TIME	60 min

## PocketRocket® 2 Mini Stove Kit

Ultra-compact complete cook-and-eat solution for one, featuring our smallest and lightest stove.

- **Ultra-compact:** Nested design slips easily into smaller day packs; makes a great back-up cook solution.
- **Ultralight:** Whole kit weighs a mere 278 g (9.8 oz), keeping pack weight to an absolute minimum.
- **Fast:** PocketRocket 2 stove boils 1 liter in 3.5 minutes.
- **Versatile:** Pot's insulated grip makes it safe to hold when hot.
- **Includes:** PocketRocket 2 stove, .75L hard-anodized aluminum pot, bowl\*, clear lid\* with straining port, ultralight pot lifter. \*BPA-free.

SIZE	One Size
SKU	14050
DIMENSIONS	10.1 x 10 x 12.7 cm (3.9 x 4 x 5 in)
WEIGHT	278 g (9.8 oz)
BOIL TIME (1 L WATER)	3.5 min
WATER BOILED (PER 8 OZ CANISTER)	16 L
BURN TIME	60 min



Black



Black



Red

## PocketRocket® Deluxe Stove Kit

Our premium cook-and-eat kit takes ultralight adventures up a notch with deluxe features.

- **Premium Kit:** Pressure-regulated, push-start PocketRocket Deluxe stove + our ultralight Trail Mini Duo Cook Set.
- **Light & Compact:** Nested design slips easily into small packs and weighs just 371 g (13.1 oz).
- **Fast:** Boils 1 liter in 3:20 minutes, maintaining fast boil times even in cold weather and with low fuel.
- **Integrated Piezo Igniter:** Fast, easy, reliable ignition.
- **Includes:** PocketRocket® Deluxe stove with stuff sack; 1.2L hard-anodized aluminum pot with insulated grip, bowl\*, strainer lid\*, ultralight pot handle, kit stuff sack, room to nest 4- or 8-oz IsoPro™ fuel. \*BPA-free.

SIZE	One Size
SKU	14106
DIMENSIONS	12.7 x 13 x 13.3 cm (5 x 5 x 5.25 in)
WEIGHT	371 g (13.1 oz)
BOIL TIME (1 L WATER)	3.3 min
WATER BOILED (PER 8 OZ CANISTER)	17 L
BURN TIME	60 min

## WindBurner® Personal Stove System

Fast, fuel-efficient personal stove system for soloists and minimalist trips.

- Optimized for backcountry soloists or pairs creating one-pot meals and quick brew-ups.
- Compact, all-in-one, fast-boil system with personal cook-and-eat features.
- 1.0L Personal Pot with handheld design locks onto stove and canister.

SIZE	One Size
SKU	14040, 14047
DIMENSIONS	10.5 x 11.3 x 18 cm (4.1 x 4.5 x 7.1 in)
WEIGHT	MINIMUM: 433 g (15.3 oz) PACKAGED: 465 g (16.4 oz)
BOIL TIME (1 L WATER)	4.5 min
WATER BOILED (PER 8 OZ CANISTER)	18 L
BURN TIME	95 min



Multi



Multi

### WindBurner® Duo Stove System

WindBurner Stove System performance sized for two backpackers.

- Ideal for trips with 2-3 people, fast-boil meals and making coffee/tea.
- Compact, all-in-one, fast-boil system with personal cook-and-eat features.
- Anti-topple remote canister design and self-centering pot.
- 1.8L Duo Pot with integrated heat exchanger & insulated cozy.

SIZE	One Size
SKU	14049
DIMENSIONS	12.5 x 12.5 x 20.5 cm (4.9 x 5 x 8 in)
WEIGHT	MINIMUM: 597 g (21.1 oz) PACKAGED: 605 g (21.3 oz)
BOIL TIME (1 L WATER)	4.5 min
WATER BOILED (PER 8 OZ CANISTER)	18 L
BURN TIME	95 min

### WindBurner® Group Stove System

Our larger capacity 2.5L system is perfect for small groups and optimized for simmering.

- Fusion® nonstick ceramic-coated 2.5L Sauce Pot serves 2-4 people.
- Features enclosed, heat-capturing ring for cooking versatility.
- Nests stove and 8-oz fuel canister for rattle-free packing efficiency.
- Anti-topple remote canister design and self-centering pot.

SIZE	One Size
SKU	13491
DIMENSIONS	19.6 x 18.3 x 14.7 cm (7.7 x 7.2 x 5.8 in)
WEIGHT	MINIMUM: 591 g (20.8 oz) PACKAGED: 599 g (21.1 oz)
BOIL TIME (1 L WATER)	6.2 min
WATER BOILED (PER 8 OZ CANISTER)	14 L
BURN TIME	95 min



Multi

## WindBurner® Stove System Combo

The ultimate tools for group and gourmet cooking.

- Fusion® nonstick ceramic-coated 2.5L Sauce Pot and 8" Skillet for multipurpose cooking.
- Features enclosed, heat-capturing ring.
- Pot nests stove and 8-oz fuel canister.
- Anti-topple remote canister design and self-centering pots.

<b>SIZE</b>	<b>One Size</b>
<b>SKU</b>	13492
<b>DIMENSIONS</b>	21.6 x 21.1 x 16.7 cm (8.5 x 8.3 x 6.6 in)
<b>WEIGHT</b>	MINIMUM: 823 g (29 oz) PACKAGED: 831 g (29.3 oz)
<b>BOIL TIME (1 L WATER)</b>	6.2 min
<b>WATER BOILED (PER 8 OZ CANISTER)</b>	14 L
<b>BURN TIME</b>	95 min



Gray

## WindBurner® Personal Accessory Pot

**1.0L pot for our WindBurner stove systems.**

- Extra pot lets you and a companion share one burner, reducing pack weight.
- Compatible with all WindBurner stove systems.
- Includes 1.0L Pot with fast-boil heat exchanger, canister stand and bowl.

SIZE	One Size
SKU	14048
DIMENSIONS	10.5 x 11.3 x 18 cm (4.1 x 4.5 x 7.1 in)
WEIGHT	247 g (8.7 oz)



Blue

## WindBurner® Duo Accessory Pot

**1.8L pot for our WindBurner stove systems.**

- Added capacity for an extra companion.
- Compatible with all WindBurner stove systems.
- **Includes:** 1.8L Pot with fast-boil heat exchanger, canister stand and bowl.

SIZE	One Size
SKU	14038
DIMENSIONS	12.5 x 12.5 x 20.5 cm (4.9 x 5 x 8 in)
WEIGHT	373 g (13.2 oz)



Gray

## WindBurner® Sauce Pot

**Ceramic-coated 2.5L pot for our WindBurner stove systems.**

- 2.5L Sauce Pot serves 2-4 people.
- Durable Fusion® ceramic coating makes meal clean-up fast and easy.
- Features enclosed, heat-capturing ring.

SIZE	One Size
SKU	13493
DIMENSIONS	19.6 x 18.3 x 14.7 cm (7.7 x 7.2 x 5.8 in)
WEIGHT	345 g (12.2 oz)



Multi

## WindBurner® Stock Pot

**Fast-boiling 4.5L pot for our WindBurner stove systems.**

- Our largest capacity pot for groups & volume cooking.
- Features high-performance heat exchanger for our fastest boil times.
- Self-centering pot fits WindBurner stoves' deep lip for increased stability.

SIZE	One Size
SKU	10370
DIMENSIONS	21 x 27.5 x 19 cm (8.25 x 10.75 x 7.5 in)
WEIGHT	586 g (20.7 oz)

**MUST  
HAVE**



Black

## WindBurner® Ceramic Skillet

**Premium nonstick performance for stir-fry, pancakes or gourmet cooking.**

- Hard-anodized aluminum skillet with Fusion® ceramic nonstick surface.
- Folding Talon™ pot handle.
- Nests outside of WindBurner Stock Pot.

<b>SIZE</b>	<b>One Size</b>
<b>SKU</b>	13494
<b>DIMENSIONS</b>	21.6 x 21.1 x 7.1 cm (8.5 x 8.3 x 2.8 in)
<b>WEIGHT</b>	216 g (7.6 oz)



Gray

## Reactor® Stove Systems

The world's fastest, most fuel-efficient all-condition stove system.

- **Choose Your Volume:** Depending on group size; systems are big enough for melting snow, small enough to go on any journey.
- **Integrated System:** State-of-the-art stove and high-efficiency cookware are combined into a compact, self-contained and easy-to-use system.
- **Unrivaled Boil Time:** Outperforms the competition in head-to-head lab tests—boiling 5 liter of water in just 1.5 minutes—with an even greater advantage out in the real world.
- **Unmatched Wind Protection:** Heat exchanger completely encloses radiant burner head, virtually eliminating the effects of wind to maintain outstanding boil times and save fuel.
- **Compact:** All systems are self-contained, fitting the stove and fuel inside the pot. (1.0L Reactor System nests optimally with our new, smaller-diameter 4 oz. canisters, which are sold separately).

SIZE	1 L	1.7 L	2.5 L
SKU	14268	14269	06902
DIMENSIONS	12.2 x 12.7 x 16 cm (4.8 x 5.0 x 6.3 in)	14.7 x 13.7 x 17 cm (5.8 x 5.4 x 6.7 in)	18.3 x 19.6 x 14.7 cm (7.2 x 7.7 x 5.8 in)
WEIGHT	MINIMUM: 422 g (14.9 oz) PACKAGED: 431 g (15.2 oz)	MINIMUM: 494 g (17.4 oz) PACKAGED: 503 g (17.7 oz)	MINIMUM: 607 g (21.4 oz) PACKAGED: 616 g (21.7 oz)
BOIL TIME (1 L WATER)	3 min		
WATER BOILED (PER 8 OZ CANISTER)	20 L	22 L	22 L
BURN TIME	80 min		



Gray

## Reactor® Cookware

**Standalone Reactor pots to replace or change your system capacity.**

- **Choose Your Volume:** Depending on group size; pots range from personal size to group capacity.
- **Integrated Cookware:** High-efficiency pots are combine with stove into a compact, self-contained and easy-to-use system.

SIZE	1 L	1.7 L	2.5 L
SKU	14270	14271	02166
DIMENSIONS	12.2 x 12.7 x 16 cm (4 x 5.0 x 6.3 in)	14.7 x 13.7 x 17 cm (5.7 x 5.4 x 6.7 in)	18.3 x 19.6 x 14.7 cm (7.2 x 7.7 x 5.8 in)
WEIGHT	240 g (8.5 oz)	299 g (10.6 oz)	391 g (13.8 oz)



Steel



Multi



Steel

## XGK™ EX Stove

The most reliable multi-fuel powerhouse ever built.

- **Multi-fuel Capability:** Burns white gas, kerosene, diesel, jet fuel, aviation gas and unleaded auto gas.
- **Unmatched Reliability:** Shaker Jet™ technology and unique fuel delivery ensure a clean burn regardless of fuel.
- **Rugged Build:** Engineered for exceptional stability and lasting durability.
- **Fast:** Boils water in as little as 2.8 minutes.

SIZE	One Size
SKU	14245
DIMENSIONS	10 x 10 x 15 cm (4 x 4 x 6 in)
WEIGHT	MINIMUM: 384 g (13.5 oz) PACKAGED: 489 g (17.2 oz)

## DragonFly® Stove

Unbeatably reliable and versatile for a wide range of meals and group sizes.

- **Unrivaled Flame Control:** Dual-valve technology allows precision boil-to-simmer control.
- **Extra-wide Pot Supports:** Easily holds up to 10"-diameter pots or fry pans.
- **Multi-fuel:** Burns white gas, kerosene, unleaded auto fuel, diesel and jet fuel.
- **Efficient:** Suspended burner cup produces a strong burn while reducing heat lost to the ground.
- **Field-maintainable:** Shaker Jet™ technology allows easy cleaning and field maintenance.

SIZE	One Size
SKU	14097, 14096
DIMENSIONS	10 x 10 x 15 cm (4 x 4 x 6 in)
WEIGHT	MINIMUM: 401 g (14.1 oz) PACKAGED: 506 g (17.8 oz)

MUST  
HAVE



Steel

## WhisperLite™ Universal Stove

World's first optimal performance hybrid-fuel stove—the most effective one ever made.

- **Hybrid Fuel:** Burns canister fuel, white gas, kerosene and unleaded gasoline.
- **Canister Liquid Feed:** Inverting canister allows stove to run on liquid fuel for increased cold-weather and low-fuel performance.
- **Groundbreaking Performance:** AirControl™ technology maximizes the fuel and air mixture with each fuel type.
- **Light and Sturdy:** Lightweight stainless steel legs offer excellent stability.
- **Easy Maintenance:** Extremely easy to swap jets and perform periodic maintenance.

SIZE	One Size
SKU	14042, 14043
DIMENSIONS	10 x 10 x 15 cm (4 x 4 x 6 in)
WEIGHT	MINIMUM: 318 g (11.2 oz) PACKAGED: 423 g (14.9 oz)

MUST  
HAVE



Steel

## WhisperLite™ International Stove

Legendary, multi-liquid-fuel performance made even better.

- **Multi-fuel:** Burns white gas, kerosene and unleaded gasoline.
- **Light & Sturdy:** Lightweight stainless steel legs offer excellent stability.
- **Proven:** Based on a design that's been proven worldwide for decades.
- **Easy Maintenance:** Extremely easy to swap jets and perform periodic maintenance.

SIZE	One Size
SKU	14044, 14045
DIMENSIONS	10 x 10 x 15 cm (4 x 4 x 6 in)
WEIGHT	MINIMUM: 318 g (11.2 oz) PACKAGED: 423 g (14.9 oz)



Red/Black



None

## MSR® Fuel Bottles

Designed to work with all MSR liquid-fuel stoves.

- **Airtight:** Allows fuel to be stored longer by preventing air to enter and degrade fuel.
- **Rugged:** Made from a single piece of impact-extruded aluminum to prevent leaks.
- **Childproof:** Push-down-and-turn child-resistant cap.

SIZE	325 mL	591 mL	887 mL
SKU	09425	09426	09427
DIMENSIONS	6.4 x 6.4 x 18.8 cm (2.5 x 2.5 x 7.4 in)	7.4 x 7.4 x 24 cm (2.9 x 2.9 x 9.4 in)	7.9 x 7.9 x 28.7 cm (3.1 x 3.1 x 11.3 in)
WEIGHT	121 g (4.3 oz)	167 g (5.9 oz)	218 g (7.7 oz)

## IsoPro™ Fuel

Our premium clean-burning, performance-boosting fuel blend.

- **Three Sizes:** 4-, 8- and 16-oz canisters meet the demands of any stove or trip; 4-oz canister fits inside the 1.0L Reactor® and WindBurner® stove systems.
- **Superior Performance:** 80/20 blend of isobutane and propane delivers superior cold-weather performance and more consistent output over the life of the canister.
- **Clean-Burning:** Zero-maintenance combustion.
- **Fuel Gauge:** Built-in float gauge determines how much fuel is left (4-oz and 8-oz canisters).

SIZE	110 g	227 g	450 g
SKU	06928	06834	04590
DIMENSIONS	9 x 9 x 6.9 cm (3.5 x 3.5 x 2.7 in)	11 x 11 x 9.4 cm (4.3 x 4.3 x 3.7 in)	12 x 12 x 15 cm (4.4 x 4.4 x 6.0 in)
WEIGHT	209 g (7.4 oz)	368 g (13.1 oz)	652 g (23 oz)
CASE PACK QUANTITY	24	24	12



Multi



Multi

## WindBurner® Coffee Press Kit

Fast-brewing coffee maker for your WindBurner Stove System.

- Turn your WindBurner Stove System into a rapid, windproof brewing machine.
- Fits WindBurner Personal and Duo Pots.

SIZE	1 L	1.8 L
SKU	09223	09312
DIMENSIONS	9.7 x 9.7 x 1.8 cm (3.8 x 3.8 x 0.7 in)	12 x 11.9 x 1.8 cm (4.7 x 4.7 x 0.7 in)
WEIGHT	37 g (1.3 oz)	141 g (1.6 oz)

## WindBurner® Hanging Kit

Secure, convenient hanging kit for the WindBurner Stove System.

- Ideal for climbing, mountaineering, ski touring and snowshoeing.
- Lightweight, durable cable system and sliding tensioner.
- Fits WindBurner Personal Stove System.

SIZE	One Size
SKU	09222
DIMENSIONS	8.7 x 0.8 x 8.6 cm (3.4 x 0.3 x 3.4 in)
WEIGHT	31 g (1.1 oz)



Multi

## Reactor® Coffee Press Kit

Turn your Reactor Stove System into the fastest coffee maker in the world.

- Etched, easy-to-clean stainless steel strainer disc for a ground-free cup of coffee.
- Disassembles and lays flat for low-profile packing.
- Fits Reactor 1.0L and 1.7L Pots.

SIZE	1 L	1.7 L
SKU	06905	06906
DIMENSIONS	11 x 10.9 x 2.3 cm (4.3 x 4.3 x 0.9 in)	13 x 13 x 2.3 cm (5.1 x 5.1 x 0.9 in)
WEIGHT	53 g (1.9 oz)	64 g (2.3 oz)



Steel

## Reactor® Hanging Kit

The ultimate hanging kit for the ultimate stove.

- Ideal for climbing, mountaineering, ski touring and snowshoeing.
- Narrow base and sliding tensioner ensure maximum stability.
- Fits all Reactor stove systems.

SIZE	One Size
SKU	06926
DIMENSIONS	8.7 x 0.8 x 8.6 cm (3.4 x 0.3 x 3.4 in)
WEIGHT	28 g (1.0 oz)



Black

## Expedition Fuel Bottle Cap

Classic, non-childproof fuel cap.

- Compatible with all MSR liquid fuel bottles.

SIZE	One Size
SKU	29129
DIMENSIONS	4 x 3.8 x 4.6 cm (1.4 x 1.5 x 1.8 in)
WEIGHT	11.34 g (0.4 oz)



Black

## Child-Resistant Fuel Bottle Cap

Provides added safety for MSR liquid fuel bottles.

- "Push-down-and-turn" cap.
- Compatible with MSR liquid fuel bottles made after 1981.
- Meets U.S. CFR1700 and Health Canada requirements.

SIZE	One Size
SKU	29133
DIMENSIONS	4.3 x 4.3 x 4.8 cm (1.7 x 1.7 x 1.9 in)
WEIGHT	11.5 g (1 oz)



Steel

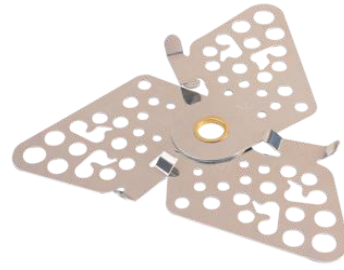

Multi

## Universal Canister Stand

Adjustable fit for worldwide compatibility.

- Super-stable wide base.
- Adjustable universal fit system ensures worldwide canister compatibility.

SIZE	One Size
SKU	05346
DIMENSIONS	3.8 x 14 x 2.5 cm (1.5 x 5.5 x 1 in)
WEIGHT	34.4 g (1.2 oz)

## Trillium™ Stove Base

Provides stability for MSR® liquid-fuel and MSR WindPro™ stoves on any terrain.

- Lightweight portable platform for resting any MSR stove on for added stability.
- MSR DragonFly® stove locks securely with the Trillium Stove Base.

SIZE	One Size
SKU	11810
DIMENSIONS	12.8 x 17 x 1.78 cm (5 x 6.7 x 0.7 in)
WEIGHT	80 g (2.8 oz)



Aluminum



Multi

## Solid Heat Reflector with Windscreen

Reflector speeds boil times, reduces fuel use.

- Windscreen improves stove performance.
- For use with MSR liquid fuel stoves or WindPro™ canister stove.

SIZE	One Size
SKU	11812
DIMENSIONS	10.2 x 2.5 x 15 cm (4 x 1 x 6 in)
WEIGHT	57 g (2 oz)

## Arctic Fuel Pump

Specifically engineered for use in temperatures below freezing.

- Designed specifically for extreme arctic temperatures.
- Seals and pump cup remain flexible to prevent leaks.
- Do not use in temperatures above freezing.
- Field-maintainable, works with all MSR liquid-fuel stoves except DragonFly®.

SIZE	One Size
SKU	09962
DIMENSIONS	5.3 x 3.8 x 16 cm (2.1 x 1.5 x 6.3 in)
WEIGHT	226 g (2.3 oz)



Multi

## Standard Fuel Pump

### Replacement fuel pump for most MSR liquid-fuel stoves.

- Self-purging pump features improved threads for added durability, is easy to adjust and won't leak when you remove it from the stove after cooking.
- Glass-reinforced polymer material is lightweight and durable.
- Improves performance of compatible MSR liquid-fuel stoves.
- For use with MSR WhisperLite™, WhisperLite™ Internationale, WhisperLite™ Universal, SimmerLite™, and XGK™ stovess; not compatible with DragonFly stove.

<b>SIZE</b>	<b>One Size</b>
<b>SKU</b>	11794
<b>DIMENSIONS</b>	5.3 x 3.8 x 16 cm (2.1 x 1.5 x 6.3 in)
<b>WEIGHT</b>	69 g (2.3 oz)



Red

## DragonFly® Fuel Pump

### Replacement fuel pump for DragonFly liquid-fuel stove.

- Self-purging pump features improved threads for added durability, is easy to adjust and won't leak when you remove it from the stove after cooking.
- Glass-reinforced polymer material is lightweight and durable.
- Improves performance of compatible MSR liquid-fuel stoves.
- For use with DragonFly liquid fuel stove.

<b>SIZE</b>	<b>One Size</b>
<b>SKU</b>	11796
<b>DIMENSIONS</b>	5.4 x 3.8 x 16 cm (2.1 x 1.5 x 6.3 in)
<b>WEIGHT</b>	69 g (2.3 oz)



Black

## Strike Igniter

### Rugged, all-weather igniter for any stove.

- Ultralight & weather-resistant.
- Moisture and pressure don't affect performance.
- Produces 5,500°F sparks to light stoves quickly.
- 3,000 to 12,000 strikes—far more than average lighters.

<b>SIZE</b>	<b>One Size</b>
<b>SKU</b>	03167
<b>DIMENSIONS</b>	2.5 x 9.7 x 1.8 cm (1 x 3.8 x 0.7 in)
<b>WEIGHT</b>	39 g (1.4 oz)



Red

## Piezo Igniter for Canister Stoves

### Push-button canister stove ignition.

- Protective metal tube houses element, collects fuel vapor for reliable ignition.
- Works with most canister stoves (except Reactor & WindBurner systems).

<b>SIZE</b>	<b>One Size</b>
<b>SKU</b>	06930
<b>DIMENSIONS</b>	1.8 x 1.8 x 8.1 cm (0.7 x 0.7 x 3.2 in)
<b>WEIGHT</b>	13 g (0.5 oz)



Multi



Multi

## Annual Maintenance Kit

Everything you need to perform annual maintenance on your liquid fuel stove and pump to ensure lasting reliability in the field.

- Services every MSR stove (except stove systems) and fuel pump.
- **Includes:** O-rings, jet-and-cable tool, and lubricant for annual preventive maintenance.

SIZE	One Size
SKU	11814
DIMENSIONS	8.4 x 4.5 x 2 cm (3.3 x 1.8 x 0.8 in)
WEIGHT	37 g (1.3 oz)





## Expedition Service Kit

Comprehensive maintenance and repair for your liquid-fuel stove and pump in places where failure is not an option.

- Maintenance and repair kits for every MSR liquid-fuel stove and pump.
- **Includes:** All components needed to replace worn or damaged stove and pump parts.





SIZE	DragonFly	WL/WLI/WLU	XGK/XGK EX
SKU	11818	06838	11816
DIMENSIONS	14.7 x 5.8 x 2.5 cm (5.8 x 2.3 x 1 in)	14.7 x 5 x 2.5 cm (5.8 x 2.3 x 1 in)	14.7 x 5.8 x 2.5 cm (5.8 x 2.3 x 1 in)
WEIGHT	99 g (3.5 oz)	108 g (3.8 oz)	113 g (4.0 oz)

## MSR® STOVES SPECIFICATIONS

CANISTER STOVES	SKU	FUEL	BOIL TIME (1L WATER)	WATER BOILED		BURN TIME (PER 8 oz CANISTER)	WEIGHT	
				PER 8 oz FUEL CANISTER	PER OUNCE OF FUEL		MINIMUM	PACKAGED
PocketRocket® Deluxe	10955	MSR® IsoPro™	3.3 min	17L	2.1L	~60 min	2.9 oz (83 g)	3.4 oz (97 g)
PocketRocket® 2	09884	MSR® IsoPro™	3.5 min	16L	2L	~60 min	2.6 oz (73 g)	3.7 oz (105 g)
WindPro™ II	14046	MSR® IsoPro™	3.6 min	15L	1.8L	~70 min	6.6 oz (187 g)	10.3 oz (292 g)
Switch™ Stove System	13844	MSR® IsoPro™	N/A	14L	1.8L	~84.5 min	4.1 oz (117 g)	13.8 oz (392 g)
WindBurner® Personal System	 14047	MSR® IsoPro™	4.5 min	18L	2.3L	~95 min	15.3 oz (433 g)	16.4 oz (465 g)
	 14040							
WindBurner® Duo System	 14049	MSR® IsoPro™	4.5 min	18L	2.3L	~95 min	21.1 oz (597 g)	21.3 oz (605 g)
WindBurner® Group System	 13491	MSR® IsoPro™	6.2 min	14L	1.8L	~95 min	20.8 oz (591 g)	21.1 oz (599 g)
WindBurner® Combo System	 13492	MSR® IsoPro™	6.2 min	14L	1.8L	~95 min	29 oz (823 g)	29.3 oz (831 g)
Reactor® 1.0L Stove System	14268	MSR® IsoPro™	3.5 min	20L	2.5L	~80 min	14.9 oz (422 g)	15.2 oz (431 g)
Reactor® 1.7L Stove System	14269	MSR® IsoPro™	3 min	22L	2.8L	~80 min	17.4 oz (494 g)	17.7 oz (503 g)
Reactor® 2.5L Stove System	06902	MSR® IsoPro™	3 min	22 L	2.8 L	~80 min	21.4 oz (607 g)	21.7 oz (616 g)

KITS & SETS	SKU	FUEL	BOIL TIME (1L WATER)	WATER BOILED		BURN TIME (PER 8 oz CANISTER)	WEIGHT
				PER 8 oz FUEL CANISTER	PER OUNCE OF FUEL		
PocketRocket® Deluxe Stove Kit	14106	MSR® IsoPro™	3.3 min	17L	2.1L	~60 min	13.1 oz (371 g)
PocketRocket® 2 Mini Stove Kit	14050	MSR® IsoPro™	3.5 min	16L	2L	~60 min	9.8 oz (278 g)
PocketRocket® Stove Kit	14272	MSR® IsoPro™	3.5 min	16L	2L	~60 min	25.8 oz (732 g)

**MSR® STOVES SPECIFICATIONS**

POTS & PANS	COLOR / SKU	BOIL TIME (1L WATER)	COMPONENTS	WEIGHT	PACKED SIZE
WindBurner® Personal Pot	 14048	4.5 min	1.0L Hard-anodized aluminum pot w/ strainer lid, insulating cozy, 16 oz cup, PackTowl® insert	8.7 oz (247 g)	10.7 x 18 cm (4.2 x 7.1 in)
WindBurner® Duo Pot	 14038	4.5 min	1.8L Hard-anodized aluminum pot w/ strainer lid, insulating cozy, 28 oz cup, PackTowl® insert	13.2 oz (373 g)	12.7 x 20.3 cm (5 x 8 in)
WindBurner® Sauce Pot	 13493	6.2 min	2.5L Fusion® ceramic coated aluminum pot w/ strainer lid and Talon™ Pot Handle	12.2 oz (345 g)	18.3 x 14.7 cm (7.2 x 5.8 in)
WindBurner® Stock Pot	 10370	3.8 min	4.5L Hard-anodized aluminum pot w/ strainer lid	20.7 oz (586 g)	21.1 x 27.4 cm (8.3 x 10.8 in)
WindBurner® Ceramic Skillet	13494		20 cm Fusion® ceramic coated aluminum skillet	7.6 oz (216 g)	21.1 x 7.1 cm (8.3 x 2.8 in)
Reactor® 1.0L Pot	14270	3.5 min	1.0L Hard-anodized aluminum pot w/ strainer lid, PackTowl® insert	8.5 oz (241 g)	12.2 x 16 cm (4.8 x 6.3 in)
Reactor® 1.7L Pot	14271	3 min	1.7L Hard-anodized aluminum pot w/ strainer lid, PackTowl® insert	10.6 oz (299 g)	13.7 x 17 cm (5.4 x 6.7 in)
Reactor® 2.5L Pot	02166	3 min	2.5L Hard-anodized aluminum pot w/ strainer lid, Talon™ Pot Handle, PackTowl® stove cozy	13.8 oz (391 g)	18.3 x 14.7 cm (7.2 x 5.8 in)

LIQUID FUEL STOVES	SKU	FUEL	BOIL TIME (1L WATER)	WATER BOILED			BURN TIME (PER 20 OZ FUEL BOT- TLE / 8 OZ CANISTER)	WEIGHT	
				PER 20 OZ FUEL BOTTLE	PER OUNCE OF FUEL	PER 100ML OF FUEL		MINIMUM	PACKAGED
XGK™ EX	14245	White Gas	3.5 min	30 L	1.5 L	4.9 L	~109 min	13.5 oz (384 g)	17.2 oz (489 g)
		Kerosene	2.8 min	34 L	1.7 L	5.7 L	~98 min		
		Diesel	4.5 min	38 L	1.9 L	6.3 L	~170 min		
DragonFly®	14096	White Gas	3.5 min	32 L	1.6 L	5.3 L	~126 min	14.1 oz (401 g)	17.8 oz (506 g)
		Kerosene	3.9 min	34 L	1.7 L	5.7 L	~153 min		
		Diesel	3.5 min	34 L	1.7 L	5.7 L	~136 min		
DragonFly® Combo	10497	White Gas	3.5 min	32 L	1.6 L	5.3 L	~126 min	14.1 oz (401 g)	17.8 oz (506 g)
		Kerosene	3.9 min	34 L	1.7 L	5.7 L	~153 min		
		Diesel	3.5 min	34 L	1.7 L	5.7 L	~136 min		
WhisperLite™ Universal	14042	White Gas	3.5 min	25 L	1.3 L	4.4 L	~110 min	11.2 oz (318 g)	14.9 oz (423 g)
		Kerosene	4.4 min	34 L	1.6 L	5.3 L	~155 min		
		MSR® IsoPro™	3.75 min	NA	1.8 L	NA	~75 min		
WhisperLite™ Universal Combo	14043	White Gas	3.5 min	25 L	1.3 L	4.4 L	~110 min	11.2 oz (318 g)	14.9 oz (423 g)
		Kerosene	4.4 min	34 L	1.6 L	5.3 L	~155 min		
		MSR® IsoPro™	3.75 min	NA	1.8 L	NA	~75 min		
WhisperLite™ International	14044	White Gas	3.5 min	25 L	1.3 L	4.4 L	~110 min	11.2 oz (318 g)	14.9 oz (423 g)
		Kerosene	4.4 min	34 L	1.6 L	5.3 L	~155 min		
WhisperLite™ International Combo	14045	White Gas	3.5 min	25 L	1.3 L	4.4 L	~110 min	11.2 oz (318 g)	14.9 oz (423 g)
		Kerosene	4.4 min	34 L	1.6 L	5.3 L	~155 min		

**WEIGHTS:** Minimum weight of liquid fuel stove includes the stove and fuel pump only. Minimum weight of canister stove includes stove only.

**NOTE:** These charts are for comparison purposes only. Testing was conducted in a room-temperature laboratory at sea level with 21° C / 70° F water. Field conditions vary in every conceivable way, which will result in different burn and boil times.

 **MSR**® COOKWARE



**COOKING UP A  
BETTER CAMP  
KITCHEN**

# 2026 COOKWARE | LINE PLAN

€€€



TITAN™ KETTLE 1400ML



TITAN™ KETTLE 900ML



TITAN™ DOUBLE WALL MUG



TITAN™ CUP 450ML



TITAN™ LONG SPOON



TITAN™ SPORK



CERAMIC 2 POT SET



CERAMIC 2.5L POT



CERAMIC SOLO POT

CERAMIC SKILLET



TRAIL LITE™ 2L POT



TRAIL LITE™ 1.3L POT



PIKA™ 1L TEAPOT

€

TITANIUM

CERAMIC NONSTICK

HARD-ANODIZED

# 2026 COOKWARE | LINE PLAN

€€€



ALPINE™  
2 POT SET



ALPINE™  
4 POT SET



ALPINE™ FRY PAN



ALPINE™ STOWAWAY™  
POTS



ALPINE™  
PLATE



ALPINE™  
NESTING BOWL



LONG SPOON



ALPINIST™ 2  
COOK SET



QUICK 2  
COOK SET



TRAIL LITE™  
SOLO  
COOK SET



TRAIL LITE™  
DUO COOK  
SET

€

STAINLESS

KITS & SETS

# TITAN™ TITANIUM

Redesigned for maximum performance and packability, our ultralight titanium collection nests together better than ever before, minimizing both weight and volume in your pack.

\*All combinations can fit a PocketRocket® 2 or PocketRocket® Deluxe stove.



## The "Ultralight & Coffee"

- PocketRocket 2 Stove
- Titan Cup 450mL
- Titan Kettle 900mL



## The Lone Thru-Hiker

- PocketRocket 2 Stove
- 4 oz. IsoPro™ fuel canister
- Titan Kettle 900mL



## The Ounce-Counting Couple

- 8 oz. IsoPro™ fuel canister
- PocketRocket Deluxe Stove
- Titan Kettle 1400mL



## The Gram-Shaving Group

- 8 oz. IsoPro™ fuel canister
- Titan Kettle 900mL
- Titan Kettle 1400mL



## The Solo Ultra-Minimalist

- PocketRocket 2 Stove
- Titan Cup 450mL





Gray

## Ceramic Solo Pot

**Lightweight nonstick aluminum pot with durable Fusion® ceramic for solo and simple backcountry meals.**

- 1.3L hard-anodized aluminum pot with ceramic interior and strainer lid.
- Folding Talon™ pot handle.

SIZE	One Size
SKU	13230
DIMENSIONS	17 x 15.7 x 9.7 cm (6.7 x 6.2 x 3.8 in)
WEIGHT	213 g (7.5 oz)



Gray

## Ceramic 2 Pot Set

**Compact nonstick set with premium Fusion® ceramic, perfect for making complex backcountry meals.**

- 1.5L hard-anodized aluminum pot with ceramic nonstick surface and strainer lid.
- 2.5L hard-anodized aluminum pot with ceramic nonstick surface.
- Folding Talon™ pot handle.
- Room for nesting mugs and plates.
- Fusion® is a registered trademark of Whitford.

SIZE	One Size
SKU	13232
DIMENSIONS	19.6 x 18.3 x 12.7 cm (7.7 x 7.2 x 5 in)
WEIGHT	443 g (15.6 oz)



Gray

## Ceramic 2.5L Pot

**Extra capacity for 2-4 people and larger dinner duties. Great for soups, sauces & gourmet fare.**

- 2.5L hard-anodized aluminum pot with Fusion® ceramic nonstick surface and strainer lid.
- Folding Talon™ pot handle.
- Nests up to three Insulated Mugs and two DeepDish™ plates.

SIZE	One Size
SKU	13231
DIMENSIONS	19.6 x 18.3 x 12.7 cm (7.7 x 7.2 x 5 in)
WEIGHT	302 g (10.7 oz)



Gray

## Ceramic Skillet

**Safe, durable Fusion® ceramic nonstick performance for stir-fry, pancakes, eggs and more.**

- Hard-anodized aluminum skillet with ceramic nonstick surface.
- Folding Talon™ pot handle.
- Nests inside a Flex™ 4 Cook Set and outside a Flex 3 Cook Set.

SIZE	One Size
SKU	13233
DIMENSIONS	21.6 x 21.1 x 5.1 cm (8.5 x 8.3 x 2 in)
WEIGHT	190 g (6.7 oz)



Gray



Gray

### Trail Lite™ 1.3L Pot

Light, rugged, reliable pot for simple meals favored by soloists on the trail.

- 1.3L hard-anodized aluminum pot with strainer lid.
- Folding, locking handle.

SIZE	One Size
SKU	14275
DIMENSIONS	15.0 x 14.5 x 10.2 cm (5.9 x 5.7 x 4 in)
WEIGHT	201 g (7.1 oz)

### Trail Lite™ 2L Pot

Light, durable, compact pot for 2, designed to save room in packs.

- 2.0L hard-anodized aluminum pot with strainer lid.
- Folding, locking handle.

SIZE	One Size
SKU	14276
DIMENSIONS	15.0 x 15.5 x 15.5 cm (5.9 x 6.1 x 6.1 in)
WEIGHT	249 g (8.8 oz)



Gray

### Pika™ 1 L Teapot

Ultralight, compact hard-anodized aluminum teapot with wide opening for easy cleaning.

- Featherweight—just 147 g (5.2 oz).
- Secure lid.
- Strong, precise pour.
- Stows PocketRocket® 2 with case or PocketRocket Deluxe stove.

SIZE	One Size
SKU	10942
DIMENSIONS	14.0 x 14.0 x 9 cm (5.5 x 5.5 x 3.5 in)
WEIGHT	147 g (5.2 oz)



Green/Blue

### Trail Lite™ Duo Cook Set

Lightweight & compact cook set for two that keeps the menu options open.

- 2.0L hard-anodized aluminum pot with strainer lid.
- (2) polypropylene Insulated Mugs.
- (2) polypropylene DeepDish™ Bowls.
- Folding, locking handle.

SIZE	One Size
SKU	14274
DIMENSIONS	15.0 x 14.5 x 15.5 cm (5.9 x 5.7 x 6.1 in)
WEIGHT	612 g (21.6 oz)



Green/Blue

## Trail Lite™ Solo Cook Set

**Lightweight & compact cookware engineered for solo travelers.**

- 1.3L hard-anodized aluminum pot with strainer lid.
- Polypropylene Insulated Mug.
- Polypropylene DeepDish™ Bowl.
- Folding, locking handle.

SIZE	One Size
SKU	14273
DIMENSIONS	15.0 x 14.5 x 10.2 cm (5.9 x 5.7 x 4 in)
WEIGHT	360 g (12.7 oz)



Red/Black

## Alpinist™ 2 Cook Set

**Ultra-light set for cooking basic meals and melting snow in remote places.**

- 2.4L hard-anodized aluminum pot with strainer lid.
- (2) polypropylene DeepDish Plates.
- Folding Talon™ pot handle.
- (2) polypropylene Insulated Mugs.
- Room for third mug or stove.

SIZE	One Size
SKU	06595
DIMENSIONS	18.3 x 18.3 x 12.2 cm (7.7 x 7.7 x 4.8 in)
WEIGHT	630 g (22.2 oz)



Red/Black

## Quick™ 2 Cook Set

**Versatile 2-pot cook set for a range of cooking utility, serving two or more.**

- 1.5L hard-anodized nonstick aluminum pot.
- 2.5L hard-anodized aluminum pot w/ strainer lid.
- Folding Talon™ Pot Handle.
- (2) polypropylene DeepDish Plates.
- (2) polypropylene Insulated Mugs.

SIZE	One Size
SKU	06597
DIMENSIONS	19.6 x 18.3 x 12.7 cm (7.7 x 7.2 x 5 in)
WEIGHT	780 g (275 oz)



Stainless Steel

## Alpine™ 2 Pot Set

**Stainless steel durability in a weight-saving cook set for two or more.**

- 1.5L and 2L stainless steel pots.
- Lid.
- PanHandler™ Pot Lifter.
- Stuff sack.

SIZE	One Size
SKU	21720
DIMENSIONS	20.8 x 19.3 x 11.2 cm (8.2 x 7.6 x 4.4 in)
WEIGHT	604 g (21.3 oz)



Stainless Steel

## Alpine™ 4 Pot Set

**Durable stainless steel cook set for preparing small group meals.**

- 1L, 2L and 3L stainless steel pots.
- 3 lids that double as plates.
- PanHandler™ Pot Lifter.
- Stuff sack.

<b>SIZE</b>	<b>One Size</b>
<b>SKU</b>	21721
<b>DIMENSIONS</b>	24.4 x 22.9 x 11.9 cm (9.6 x 9 x 4.7 in)
<b>WEIGHT</b>	1109 g (39.1 oz)



Stainless Steel

## Alpine™ StowAway™ Pots

**Durable stainless steel pots with hinged handles for easy lifting and secure storage.**

- Rugged stainless steel pots stand up to heavy use and campfire cooking.
- Great for storing gear or supplies when not cooking.
- Hinged, easy-lift handle flips over the fitted lid to lock it in place.

SIZE	475 mL	775 mL	1.1 L	1.6 L
SKU	321107	321108	321109	321111
DIMENSIONS	11.7 x 11.7 x 7.6 cm (4.6 x 4.6 x 3 in)	14.2 x 14.2 x 8.6 cm (5.6 x 5.6 x 3.4 in)	16.5 x 16.5 x 9.7 cm (6.5 x 6.5 x 3.8 in)	18.3 x 18.3 x 10.2 cm (7.2 x 7.2 x 4 in)
WEIGHT	270 g (9.5 oz)	365 g (13 oz)	440 g (15.5 oz)	550 g (19.5 oz)



Stainless Steel

## Alpine™ Fry Pan

**Featuring stainless steel durability for heavy use.**

- Bimetal pan with folding handle.
- Extra layer of metal on bottom to diffuse heat more evenly.
- Nests over Alpine 3L pots.

SIZE	One Size
SKU	21611
DIMENSIONS	19.8 x 19.6 x 4.8 cm (7.8 x 7.7 x 1.9 in)
WEIGHT	312 g (11 oz)



Stainless Steel

## Alpine™ Nesting Bowl

**Rugged, space-saving stainless steel bowls.**

- Bowls also fit inside Alpine 2 Pot Set.

SIZE	One Size
SKU	03138
DIMENSIONS	14.7 x 14.7 x 5.6 cm (5.8 x 5.8 x 2.2 in)
WEIGHT	84 g (3 oz)



Stainless Steel

## Alpine™ Plate

**Strong, lightweight stainless steel plate.**

- Nests with Alpine 2L and 3L pots.

SIZE	One Size
SKU	321104
DIMENSIONS	20.3 x 20 x 2.5 cm (8 x 8 x 1 in)
WEIGHT	126 g (4.4 oz)



Stainless Steel

## Alpine™ Long Tool Spoon

**Extra-long spoon and stove maintenance tool in one.**

- Durable stainless steel spoon.
- Long handle to reach meals in tall pots and re-sealable stand-up pouches.
- Integrated jet-and-cable tool for liquid fuel stoves.

SIZE	One Size
SKU	09523
DIMENSIONS	2.5 x 22.9 x 1.3 cm (1 x 10 x 0.5 in)
WEIGHT	60 g (3 oz)

MUST  
HAVE



Titanium



## Titan™ Kettle 900mL

Ultralight and durable cookpot for one can be used as bowl or mug.

- Improved spout for easy pouring into dehydrated meal pouch.
- Silicone-coated handles fold closed for packing and are comfortable to hold.
- Internal graduation marks for easy volume measurements.
- Snug-fit lid with improved handle stays secure in pack.
- Nests inside 1400mL kettle.

SIZE	One Size
SKU	13845
DIMENSIONS	11.2 x 12.4 x 11.2 cm (4.4 x 4.8 x 4.4 in)
WEIGHT	126 g (4.4 oz)



Titanium



## Titan™ Kettle 1400mL

Large ultralight kettle for backcountry duos who want to boil water or melt snow.

- Improved spout for easy pouring into dehydrated meal pouch.
- Silicone-coated handles fold closed for packing and are comfortable to hold.
- Internal graduation marks for easy volume measurements.
- Snug-fit lid with improved handle stays secure in pack.

SIZE	One Size
SKU	13846
DIMENSIONS	13 x 13.8 x 13 cm (5.1 x 5.4 x 5.1 in)
WEIGHT	153 g (5.4 oz)



Titanium

## Titan™ Cup 450mL

The ultimate minimalist cookpot or ultralight cup to accompany a kettle.

- Silicone lip saver band; remove before heating cup.
- Silicone-coated handles flip closed for packing and are comfortable to hold.
- Internal graduation marks for easy volume measurements.
- Nests in 900mL kettle.

SIZE	One Size
SKU	13847
DIMENSIONS	9.1 x 9.1 x 9.3 cm (3.5 x 3.6 x 3.8 in)
WEIGHT	68 g (2.4 oz)



Titanium



## Titan™ Double Wall Mug

Double-wall performance that's light enough for the backcountry.

- Exceptional heat retention in an ultralight package.
- Durable plastic sipper lid.

SIZE	One Size
SKU	13848
DIMENSIONS	9.3 x 9 x 9.3 cm (3.6 x 3.5 x 3.7 in)
WEIGHT	116 g (4.1 oz)



Titanium

## Titan™ Long Spoon

Ultralight and extra-long for reaching into dehydrated meal pouches.

- Spoon bowl is sized for comfortable mouthfeel.
- Carabiner loop.

<b>SIZE</b>	<b>One Size</b>
<b>SKU</b>	13850
<b>DIMENSIONS</b>	4 x 21.2 x 0.73 cm (1.6 x 8.3 x 0.29 in)
<b>WEIGHT</b>	19 g (0.7 oz)



Titanium

## Titan™ Spork

The reigning utensil champ of ultralight versatility.

- Carabiner loop.

<b>SIZE</b>	<b>One Size</b>
<b>SKU</b>	13849
<b>DIMENSIONS</b>	4 x 16.1 x 0.73 cm (1.6 x 6.3 x 0.29 in)
<b>WEIGHT</b>	15 g (0.5 oz)



Red/Black

## Alpine™ Deluxe Kitchen Set

Comprehensive kitchen kit and deluxe carry case for basecamps and frontcountry use.

- **Includes:** Alpine Folding Utensil Set, Salt & Pepper Shaker, Dish Brush/Scraper, Kitchen Knife, Deluxe Cutting Board, dish towel, bottle opener/corkscrew, squeeze bottles, Deluxe Case.

<b>SIZE</b>	<b>One Size</b>
<b>SKU</b>	05337
<b>DIMENSIONS</b>	7.6 x 18 x 24 cm (3 x 7 x 9.5 in)
<b>WEIGHT</b>	640.4 g (22.6 oz)



Red/Black

## Ultralight Kitchen Set

A lightweight kitchen set with utensils and accessories in one convenient package.

- **Includes:** Folding Spoon, Spatula, Ultralight Cutting Board, Salt & Pepper Shaker, squeeze bottle, dish towel.

<b>SIZE</b>	<b>One Size</b>
<b>SKU</b>	03140
<b>DIMENSIONS</b>	15.2 x 20 x 6.4 cm (6 x 8 x 2.5 in)
<b>WEIGHT</b>	136 g (4.8 oz)



Red/Black

### Alpine™ Dish Brush/Scraper

Fast-drying, mildew-resistant brush with custom-formed handle that doubles as a scraper.

SIZE	One Size
SKU	05331
DIMENSIONS	6.4 x 8.9 x 1.3 cm (2.5 x 3.5 x 0.5 in)
WEIGHT	22 g (0.8 oz)



Red

### Alpine™ Deluxe Cutting Board

Hinged cutting board folds in half for packing. Available as part of Alpine Deluxe Kitchen Set or on its own.

SIZE	One Size
SKU	05340
DIMENSIONS	19 x 28 x 0.3 cm (7.5 x 11 x 0.125 in)
WEIGHT	176.6 g (6.2 oz)



Blue

### Alpine™ Kitchen Knife

All-purpose, hardened stainless steel utility knife with easy-to-clean plastic sheath.

SIZE	One Size
SKU	07091
DIMENSIONS	3.6 x 18 x 1.3 cm (1.4 x 7 x 0.5 in)
WEIGHT	48.2 g (1.7 oz)



Red

### Alpine™ Chef's Knife

Modified Santoku design with high-grade stainless steel excels at chopping and slicing.

SIZE	One Size
SKU	06924
DIMENSIONS	1.3 x 25 x 6.4 cm (0.5 x 10 x 2.5 in)
WEIGHT	99 g (3.5 oz)



Red/Black

## Alpine™ Salt & Pepper Shaker

Rugged, BPA-free containers with water-resistant lid, center divider & spice shaker caps.

<b>SIZE</b>	<b>One Size</b>
<b>SKU</b>	05338
<b>DIMENSIONS</b>	1.9 x 1.9 x 7.6 cm (0.75 x 0.75 x 3 in)
<b>WEIGHT</b>	9.4 g (0.3 oz)



Black/Copper



## MugMate™ Coffee/Tea Filter

A low-profile, reusable coffee/tea filter that can be stored in just about any mug or cup.

<b>SIZE</b>	<b>One Size</b>
<b>SKU</b>	321003
<b>DIMENSIONS</b>	9 x 9 x 7.6 cm (3.5 x 3.5 x 3 in)
<b>WEIGHT</b>	28 g (1 oz)



Blue



Red

Red / Gray

Red / Gray / Blue / Green

## Folding Utensils

Locking mechanism allows for secure use in the open position. Multiple color options.

SIZE	Red Spork	Blue Spork	4 Piece Spoon & Fork Kit	4 Piece Spork Kit
SKU	06908	06911	03169	03170
DIMENSIONS	3.8 x 20 x 1.3 cm (1.5 x 8 x 0.5 in)			
WEIGHT	9.5 g (0.35 oz)	9.5 g (0.35 oz)	38 g (1.4 oz)	38 g (1.4 oz)



Blue/Green

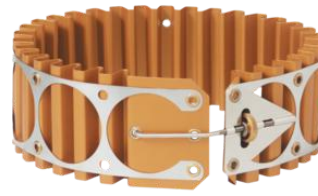

Aluminum

## 2 Person Mess Kit

A mess kit with color-matching bowls, mugs and utensils that easily nests inside the Trail Lite™ 2L Pot.

- **Includes:** (2) Insulated Mugs, (2) DeepDish™ Bowls, (2) Folding Sporks, mesh bag.

SIZE	One Size
SKU	03137
DIMENSIONS	14 x 14 x 14 cm (5.5 x 5.5 x 5.5 in)
WEIGHT	136 g (13.2 oz)

## Heat Exchanger

Increased heat efficiency & wind protection for all 1.5L and 2L MSR pots.

SIZE	One Size
SKU	321105
DIMENSIONS	20.3 x 20.3 x 9.5 cm (8 x 8 x 3.75 in)
WEIGHT	170 g (6 oz)



Aluminum

## PanHandler™

Pot lifter for all MSR cookware—supports up to 4.5 kg (10 lb), comes with a PackTowl® sleeve.

SIZE	One Size
SKU	13000
DIMENSIONS	3.9 x 13 x 3.8 cm (1.5 x 5.25 x 1.5 in)
WEIGHT	56 g (1.9 oz)

**MSR® COOKWARE SPECIFICATIONS**

TITANIUM	SKU	COMPONENTS	WEIGHT	PACKED SIZE DIAMETER x HEIGHT
Titan™ Kettle 900mL	13845	900mL Titanium kettle with lid	126 g (4.4 oz)	12.4 x 11.2 cm (4.9 x 4.4 in)
Titan™ Kettle 1400mL	13846	1400mL Titanium kettle with lid	153 g (5.4 oz)	13.8 x 13.0 cm (5.4 x 5.1 in)
CERAMIC NONSTICK	SKU	COMPONENTS	WEIGHT	PACKED SIZE DIAMETER x HEIGHT
Ceramic Solo Pot	13230	1.3L Fusion® ceramic nonstick aluminum pot w/ strainer lid, Talon™ Pot Handle	213 g (7.5 oz)	15.7 x 9.7 cm (6.2 x 3.8 in)
Ceramic 2.5L Pot	13231	2.5L Fusion® ceramic nonstick aluminum pot w/ strainer lid, Talon™ Pot Handle	302 g (10.7 oz)	18.3 x 12.7 cm (7.2 x 5 in)
Ceramic 2 Pot Set	13232	1.5L Fusion® ceramic nonstick aluminum pot, 2.5L Ceramic nonstick aluminum pot w/ strainer lid, Talon™ Pot Handle	443 g (15.6 oz)	18.3 x 12.7 cm (7.2 x 5 in)
Ceramic Skillet	13233	Fusion® ceramic nonstick aluminum skillet, Talon™ Pot Handle	190 g (6.7 oz)	21.1 x 5.1 cm (8.3 x 2 in)
HARD-ANODIZED	SKU	COMPONENTS	WEIGHT	PACKED SIZE DIAMETER x HEIGHT
Pika™ 1L Teapot	10942	1L hard-anodized aluminum pot with lid	147 g (5.2 oz)	14 x 8.9 cm (5.5 x 3.5 in)
Trail Lite 1.3L Pot	14275	1.3L hard-anodized aluminum pot with lid	201 g (7.1 oz)	14.5 x 10.2 cm (5.7 x 4 in)
Trail Lite 2.0L Pot	14276	2L hard-anodized aluminum pot with lid	249 g (8.8 oz)	14.5 x 15.5 cm (5.7 x 6.1 in)
STAINLESS STEEL	SKU	COMPONENTS	WEIGHT	PACKED SIZE DIAMETER x HEIGHT
Alpine™ 4 Pot Set	21721	1L Stainless steel pot w/ lid, 2L Stainless steel pot w/ lid, 3L Stainless steel pot w/ lid, PanHandler™ Pot Lifter	1109 g (39.1 oz)	22.9 x 11.9 cm (9 x 4.7 in)
Alpine™ 2 Pot Set	21720	1.5L Stainless steel pot w/ plate lid, 2L Stainless steel pot w/ plate lid, PanHandler™ Pot Lifter	604 g (21.3 oz)	19.3 x 11.2 cm (7.6 x 4.4 in)
Alpine™ StowAway Pots	475mL: 321107 775mL: 321108 1.1L: 321109 1.6L: 321111	Stainless steel with folding handles	270 g (9.5 oz) 365 g (13 oz) 440 g (15.5 oz) 550 g (19.5 oz)	11.7 x 7.6 cm (4.6 x 3 in) 14.2 x 8.6 cm (5.6 x 3.4 in) 16.5 x 9.7 cm (6.5 x 3.8 in) 18.3 x 10.2 cm (7.2 x 4 in)
Alpine™ Fry Pan	21611	Stainless steel fry pan w/ folding handle	312 g (11 oz)	19.6 x 4.8 cm (7.7 x 1.9 in)
KITS & SETS	SKU	COMPONENTS	WEIGHT	PACKED SIZE DIAMETER x HEIGHT
Trail Lite™ Duo Cook Set	14274	2.0L Hard-anodized aluminum pot, Clear strainer lid, (2) Insulated Mugs, (2) DeepDish™ Bowls	612 g (21.6 oz)	14.5 x 15.5 cm (5.7 x 6.1 in)
Trail Lite™ Solo Cook Set	14273	1.3L Hard-anodized aluminum pot w/ strainer lid, Insulated Mug, DeepDish™ Bowl	360 g (12.7 oz)	14.5 x 10.2 cm (5.7 x 4 in)
Alpinist™ 2 Cook Set	06595	2.4L Hard-anodized aluminum pot w/ strainer lid, (2) DeepDish™ Plates, (2) Insulated Mugs, Talon™ Pot Handle	630 g (22.2 oz)	18.3 x 12.2 cm (7.2 x 4.8 in)
Quick 2 Cook Set	06597	1.5L Nonstick hard-anodized aluminum pot, 2.5L Hard-anodized aluminum pot w/ strainer lid, Talon™ Pot Handle, (2) Insulated Mugs, (2) DeepDish™ Plates	780 g (27.5 oz)	18.3 x 12.7 cm (7.2 x 5 in)

**MSR® WINTER**



**PRECISION  
ENGINEERING FOR  
WINTER EXPLORATION**

# HOW TO CHOOSE MSR BINDINGS



## PARAGLIDE™ TRAIL SERIES

**Benefit:** Intuitive to use, extremely comfortable and made from high-quality materials.

**Made for:** Entry-level snowshoers who want equipment that offers confidence; more advanced snowshoers who want lighter weight shoes for less technical terrain, and utility users in cold climates who need snowshoes in their everyday lives.

 **Terrain:** Rolling, gentle



## PARADIGM™ EXPLORE SERIES

**Benefit:** Secure performance, lightweight comfort, easy use and repairability.

**Made for:** Intermediate to advanced level snowshoers who are exploring moderate to technical terrain; beginner snowshoers who know they want to invest in shoes they can grow into over time.

 **Terrain:** Variable



## PARAGON™ ASCENT SERIES

**Benefit:** High-precision foot control for safe travel on steep ascents, challenging sidehills and icy conditions; reliable durability and field repairability.

**Made for:** Serious winter adventurers who demand superior snowshoes for safe and successful travel in extreme and remote environments.

 **Terrain:** Aggressive, steep



# 2026 WINTER | LINE PLAN

€€€



**LIGHTNING™ ASCENT**  
(Men's & Women's)



**REVO™ ASCENT**  
(Men's & Women's)



**LIGHTNING™ EXPLORE**  
(Men's & Women's)



**REVO™ EXPLORE**  
(Men's & Women's)



**EVO™ EXPLORE**  
(Men's & Women's)

€

**ASCENT**

**EXPLORE**

# 2026 WINTER | LINE PLAN

€€€



**LIGHTNING™ TRAIL**  
(Men's & Women's)



**REVO™ TRAIL**  
(Men's & Women's)



**EVO™ TRAIL**



**TYKER™**



**EVO™ TRAIL KIT**



**DYNALOCK™ ASCENT CARBON**



**DYNALOCK™ EXPLORE**



**DYNALOCK™ TRAIL**

€

**TRAIL**

**KIDS**

**POLES & KITS**

**MUST HAVE**



Black



Cobalt Blue

**MUST HAVE**



Gunmetal



Raspberry

## Lightning™ Ascent Snowshoes

The pinnacle of ultralight and aggressive all-terrain performance.

- **Unrivaled Traction:** 360° Traction frames deliver edge-to-edge grip, and durable steel DTX crampons provide serious bite in challenging conditions—delivering unmatched traction in technical terrain.
- **Paragon™ Binding:** Comfortable, freeze-resistant mesh strap wraps securely around a wide range of boots for ultimate security, while toe stops offer fast, precise foot alignment.
- **All-Condition Adaptability:** Attachment points for 5-inch (13-cm) modular flotation tails (sold separately), which provide on-demand flotation for deep powder or when carrying heavier loads.
- **Uphill Efficiency:** Ergo™ Televators reduce fatigue and increase traction on the steeps with an ergonomic design that engages with a flick of a pole grip.

SIZE	22 in	25 in	30 in
SKU	13079, 13076	13080, 13077	13081, 13078
DIMENSIONS	20 x 56 x 10 cm (8 x 22 x 4 in)	20 x 64 x 10 cm (8 x 25 x 4 in)	20 x 76 x 10 cm (8 x 30 x 4 in)
WEIGHT PER PAIR	1874 g (66.8 oz)	1946 g (69.3 oz)	2218 g (78.9 oz)
BINDING TYPE	Paragon™		
DECK MATERIAL	TPU coated Nylon		
FRAME MATERIAL	7075-T6 Aluminum		
LOAD W/O TAILS	Up to 80 kilos (Up to 180 lbs )	54 - 100+ kilos (120 - 220 lbs )	68 - 127+ kilos (150 - 280 lbs )

## Women's Lightning™ Ascent Snowshoes

Ultralight and aggressive performance engineered for a narrow gait.

- **Unrivaled Traction:** 360° Traction frames deliver edge-to-edge grip, while durable steel DTX crampons provide serious bite in challenging conditions—delivering unmatched traction in technical terrain.
- **Women's Paragon™ Binding:** Comfortable mesh strap sized for women wraps securely around a wide range of footwear, including smaller boots, offering ultimate control. Toe stops ensure fast, easy foot placement.
- **All-Condition Adaptability:** Attachment points for 5-inch (13-cm) modular flotation tails (sold separately), which provide on-demand flotation for deep powder or when carrying heavier loads.
- **Uphill Efficiency:** Ergo™ Televators reduce fatigue and increase traction on the steeps with an ergonomic design that engages with a flick of a pole grip.
- **Low-Profile:** Narrow frames improve agility for those with a narrow gait and are ideal for anyone seeking a lighter snowshoe.

SIZE	22 in	25 in
SKU	13084, 13082	13085, 13083
DIMENSIONS	18 x 56 x 10 cm (7.25 x 22 x 4 in)	18 x 64 x 10 cm (7.25 x 25 x 4 in)
WEIGHT PER PAIR	1740 g (61.4 oz)	1812 g (64.6 oz)
BINDING TYPE	Paragon™	
DECK MATERIAL	TPU coated Nylon	
FRAME MATERIAL	7075-T6 Aluminum	
LOAD W/O TAILS	Up to 80 kilos (Up to 180 lbs )	54 - 95 kilos (120 - 210 lbs )



Moss



Drift

## Lightning™ Explore Snowshoes

Ultralight and secure to take on challenging conditions with ease.

- **Unrivaled Traction:** Aggressive 360° Traction frames provide advanced traction, especially on traverses and in challenging conditions.
- **Paradigm™ Binding:** The trifecta of durable performance, secure comfort and easy reparability, with stretch mesh that cradles your feet for a pressure-point-free hold.
- **Lightweight:** TPU-coated nylon deck is lightweight and quiet on snow.
- **Uphill Efficiency:** Ergo™ Televators reduce fatigue and increase traction on the steepes, with an ergonomic design that engages with a flick of a pole grip.
- **All-Condition Adaptability:** Attachment points for 5-inch (13-cm) modular flotation tails (sold separately), which provide on-demand flotation for deep powder or when carrying heavier loads.

SIZE	22 in	25 in	30 in
SKU	13727	13726	13725
DIMENSIONS	20 x 56 x 8 cm (8 x 22 x 3 in)	20 x 64 x 8 cm (8 x 25 x 3 in)	20 x 76 x 8 cm (8 x 30 x 3 in)
WEIGHT PER PAIR	1612 g (57 oz)	1689 g (60 oz)	1960 g (69 oz)
BINDING TYPE	Paradigm™		
DECK MATERIAL	TPU coated Nylon		
FRAME MATERIAL	7075-T6 Aluminum		
LOAD W/O TAILS	Up to 80 kilos (Up to 180 lbs )	54 - 100+ kilos (120 - 220 lbs )	68 - 127+ kilos (150 - 280 lbs )

## Women's Lightning™ Explore Snowshoes

Lightweight, comfortable performance, engineered for a narrow gait.

- **Unrivaled Traction:** 360° Traction frames and Pivot™ crampons deliver reliable grip in variable terrain and conditions, both on the trails and off.
- **Women's Paradigm™ Binding:** The trifecta of durable performance, secure comfort and easy reparability, with stretch mesh that cradles your feet for a pressure-point-free hold and straps sized for smaller footwear.
- **Lightweight:** TPU-coated nylon deck is lightweight and quiet on snow.
- **Uphill Efficiency:** Ergo™ Televators reduce fatigue and increase traction on the steepes, with an ergonomic design that engages with a flick of a pole grip.
- **Slim Design:** Tapered deck is ideal for women or anyone with a narrow gait to increase agility.
- **All-Condition Adaptability:** Attachment points for 5-inch (13-cm) Modular Flotation tails (sold separately), which provide on-demand flotation for deep powder or when carrying heavier loads.

SIZE	22 in	25 in
SKU	13729	13728
DIMENSIONS	18 x 56 x 8 cm (7.25 x 22 x 3 in)	18 x 64 x 8 cm (7.25 x 25 x 3 in)
WEIGHT PER PAIR	1537 g (54 oz)	1571 g (55 oz)
BINDING TYPE	Paradigm™	
DECK MATERIAL	TPU coated Nylon	
FRAME MATERIAL	7075-T6 Aluminum	
LOAD W/O TAILS	Up to 80 kilos (Up to 180 lbs )	54 - 95 kilos (120 - 210 lbs )



Ranger



Hops

## Lightning™ Trail Snowshoes

**Ultralight traction and comfortable all-day performance.**

- **Ultralight:** Streamlined TPU-coated nylon deck is lightweight and quiet on snow, tailored for energy-saving performance.
- **Aggressive Traction:** 360° Traction frames with perimeter teeth and Pivot™ crampons deliver advanced, edge-to-edge grip.
- **All-Day Comfort:** Paraglide™ binding stretch mesh hugs feet securely and is compatible with nearly any footwear, from light hikers to snowboard boots.
- **Easy to Use:** Glove-friendly binding straps and buckle tabs make getting in and out quick and simple.
- **Uphill Efficiency:** Ergo™ Televators reduce fatigue and increase traction on the steeps, with an ergonomic design that engages with a flick of a pole grip.
- **All-Condition Adaptability:** Attachment points for 5-inch (13-cm) modular flotation tails (sold separately), which provide on-demand flotation for deep powder or when carrying heavier loads.

SIZE	22 in	25 in
SKU	13639	13638
DIMENSIONS	20 in 56 in 8 in 22 in	20 in 64 in 8 in 25 in
WEIGHT PER PAIR	1593 g (56.2 oz)	1659 g (58.5 oz)
BINDING TYPE	Paraglide™	
DECK MATERIAL	TPU-coated Nylon	
FRAME MATERIAL	7075-T6 Aluminum	
LOAD W/O TAILS	Up to 80 kilos (Up to 180 lbs )	54 - 100 kilos (120 - 220 lbs )

## Women's Lightning™ Trail Snowshoes

**Ultralight traction and comfortable all-day performance for narrow strides.**

- **Ultralight:** Streamlined TPU-coated nylon deck is lightweight and quiet on snow, tailored for energy-saving performance.
- **Aggressive Traction:** 360° Traction frames with perimeter teeth and Pivot™ crampons deliver advanced, edge-to-edge grip.
- **Slim Design:** Tapered deck is ideal for women or anyone with a narrow gait.
- **All-Day Comfort:** Paraglide™ binding stretch mesh hugs feet securely and is compatible with nearly any footwear, from light hikers to snowboard boots.
- **Easy to Use:** Glove-friendly binding straps and buckle tabs make getting in and out quick and simple.
- **Uphill Efficiency:** Ergo™ Televators reduce fatigue and increase traction on the steeps, with an ergonomic design that engages with a flick of a pole grip.
- **All-Condition Adaptability:** Attachment points for 5-inch (13-cm) modular flotation tails (sold separately), which provide on-demand flotation for deep powder or when carrying heavier loads.

SIZE	22 in	25 in
SKU	13641	13640
DIMENSIONS	18 in 56 in 7.25 in 22 in	18 in 64 in 7.25 in 25 in
WEIGHT PER PAIR	1533 g (54.1 oz)	1565 g (55.2 oz)
BINDING TYPE	Paraglide™	
DECK MATERIAL	TPU coated Nylon	
FRAME MATERIAL	7075-T6 Aluminum	
LOAD W/O TAILS	Up to 80 kilos (Up to 180 lbs )	54 - 95 kilos (120 - 210 lbs )



Elemental Blue



Blaze Orange

## Women's Revo™ Explore Snowshoes

**Efficient, all-day comfort and performance, engineered for a narrow gait.**

- **External Traction:** Rugged perimeter teeth of the ExoTract deck and steel crampons deliver reliable grip in variable terrain and conditions, both on the trails and off.
- **Durable:** Injection-molded plastic deck withstands abusive conditions and adds torsional flex for deep purchase in snow.
- **Women's Paradigm™ Binding:** The trifecta of durable performance, secure comfort and easy repairability, with stretch mesh that cradles your feet for a pressure-point-free hold and straps sized for smaller footwear.
- **Uphill Efficiency:** Ergo™ Televators reduce fatigue and increase traction on the steeps with an ergonomic design that engages with a flick of a pole grip.
- **Slim Design:** Tapered deck is ideal for women or anyone with a narrow gait to increase agility.
- **All-Condition Adaptability:** Attachment points for 5-inch (13-cm) Modular Flotation tails (sold separately), which provide on-demand flotation for deep powder or when carrying heavier loads.

SIZE	22 in	25 in
SKU	13733	13732
DIMENSIONS	20 in 56 in 8 in 22 in	20 in 64 in 8 in 25 in
WEIGHT PER PAIR	1657 g (58 oz)	1793 g (63 oz)
BINDING TYPE	Paradigm™	
DECK MATERIAL	Polypropylene	
FRAME MATERIAL	Martensitic Steel	
LOAD W/O TAILS	Up to 80 kilos (Up to 180 lbs )	54 - 95 kilos (120 - 210 lbs )

## Revo™ Explore Snowshoes

**Versatile and efficient for variable terrain.**

- **External Traction:** Aggressive perimeter teeth of the ExoTract deck and Pivot™ crampons provide advanced traction, especially on traverses and in challenging conditions.
- **Durable:** Injection-molded plastic deck withstands abusive conditions and adds torsional flex for deep purchase in snow.
- **Paradigm™ Binding:** The trifecta of durable performance, secure comfort and easy repairability, with stretch mesh that cradles your feet for a pressure-point-free hold.
- **Uphill Efficiency:** Ergo™ Televators reduce fatigue and increase traction on the steeps with an ergonomic design that engages with a flick of a pole grip.
- **All-Condition Adaptability:** Attachment points for 5-inch (13-cm) Modular Flotation tails (sold separately), which provide on-demand flotation for deep powder or when carrying heavier loads.

SIZE	22 in	25 in
SKU	13731	13730
DIMENSIONS	20 in 56 in 8 in 22 in	20 in 64 in 8 in 25 in
WEIGHT PER PAIR	1761 g (62 oz)	1888 g (67 oz)
BINDING TYPE	Paradigm™	
DECK MATERIAL	Polypropylene	
FRAME MATERIAL	Martensitic Steel	
LOAD W/O TAILS	Up to 80 kilos (Up to 180 lbs )	54 - 100 kilos (120 - 220 lbs )



Gray



Olive



Dark Cyan

## Revo™ Ascent Snowshoes

**Rock-solid durability, security, and all-terrain performance.**

- **External Traction:** Aggressive perimeter teeth and durable steel DTX crampons deliver advanced traction, especially on traverses and in challenging conditions.
- **Durable:** Injection-molded plastic deck withstands abusive conditions and offers a subtle torsional flex underfoot for excellent purchase.
- **Paragon™ Binding:** Comfortable, freeze-resistant mesh strap wraps securely around a wide range of boots for ultimate control, while toe stops offer fast, precise foot alignment.
- **Uphill Efficiency:** Ergo Televators reduce fatigue and increase traction on the steepes with an ergonomic design that engages with a flick of a pole grip.
- **All-Condition Adaptability:** Attachment points for 5-inch (13-cm) modular flotation tails (sold separately), which provide on-demand flotation for deep powder or when carrying heavier loads.

SIZE	22 in	25 in
SKU	13243, 13092	13244, 13093
DIMENSIONS	20.3 in 56 in 8 in 22 in	20.3 in 64 in 8 in 25 in
WEIGHT PER PAIR	2026 g (71.4 oz)	2144 g (75.6 oz)
BINDING TYPE	Paragon	
DECK MATERIAL	Polypropylene	
FRAME MATERIAL	Martensite Steel	
LOAD W/O TAILS	Up to 80 kilos (Up to 180 lbs )	54 - 100 kilos (120 - 220 lbs )

## Women's Revo™ Ascent Snowshoes

**Rock-solid durability, security and all-terrain performance, engineered for a narrow stride.**

- **Women's ExoTract Deck:** Slightly tapered deck improves agility for those with a narrow stride and saves weight for those looking for the lightest option in this ultra-durable, aggressive snowshoe.
- **Women's Paragon™ Binding:** Comfortable mesh strap sized for women wraps securely around a wide range of footwear, including smaller boots, offering ultimate control. Toe stops ensure fast, easy foot placement.
- **All-Condition Adaptability:** Attachment points for 5-inch (13-cm) modular flotation tails (sold separately), which provide on-demand flotation for deep powder or when carrying heavier loads.
- **Uphill Efficiency:** Ergo Televators reduce fatigue and increase traction on the steepes with an ergonomic design that engages with a flick of a pole grip.

SIZE	22 in	25 in
SKU	13094	13095
DIMENSIONS	20.3 in 56 in 8 in 22 in	20.3 in 56 in 8 in 25 in
WEIGHT PER PAIR	1909 g (67.3 oz)	2059 g (72.7 oz)
BINDING TYPE	Paragon	
DECK MATERIAL	Polypropylene	
FRAME MATERIAL	Martensite Steel	
LOAD W/O TAILS	Up to 80 kilos (Up to 180 lbs )	54 - 95 kilos (120 - 210 lbs )



Marine Fog



Iron

## Revo™ Trail Snowshoes

Versatile, lightweight performance for rolling terrain.

- **Traction:** Strong injection-molded ExoTract™ deck with steel crampon and perimeter teeth provides torsional flex and excellent grip for deep purchase in a variety of snow conditions.
- **All-Day Comfort:** Paraglide™ binding stretch mesh hugs feet securely and is compatible with nearly any footwear, from light hikers to snowboard boots.
- **Easy to Use:** Glove-friendly binding straps and buckle tabs make getting in and out quick and simple.
- **Uphill Efficiency:** Ergo™ Televators reduce fatigue and increase traction on the steepes, with an ergonomic design that engages with a flick of a pole grip.
- **All-Condition Adaptability:** Attachment points for 5-inch (13-cm) modular flotation tails (sold separately), which provide on-demand flotation for deep powder or when carrying heavier loads.

SIZE	22 in	25 in
SKU	13635	13634
DIMENSIONS	20 in 56 in 8 in 22 in	20 in 64 in 8 in 25 in
WEIGHT PER PAIR	1707 g (60.2 oz)	1834 g (64.7 oz)
BINDING TYPE	Paraglide™	
DECK MATERIAL	Polypropylene	
FRAME MATERIAL	Martensitic Steel	
LOAD W/O TAILS	Up to 80 kilos (Up to 180 lbs )	54 - 100 kilos (120 - 220 lbs )

## Women's Revo™ Trail Snowshoes

Versatile performance for narrow strides in rolling terrain.

- **Efficient Traction:** Strong injection-molded ExoTract™ deck with steel crampon and perimeter teeth provides torsional flex and excellent grip for deep purchase in a variety of snow conditions.
- **All-Day Comfort:** Paraglide™ binding stretch mesh hugs feet securely and is compatible with nearly any footwear, from light hikers to snowboard boots.
- **Easy to Use:** Glove-friendly binding straps and buckle tabs make getting in and out quick and simple.
- **Uphill Efficiency:** Ergo™ Televators reduce fatigue and increase traction on the steepes, with an ergonomic design that engages with a flick of a pole grip.
- **Slim Design:** Tapered deck is ideal for women or anyone with a narrow gait.
- **All-Condition Adaptability:** Attachment points for 5-inch (13-cm) modular flotation tails (sold separately), which provide on-demand flotation for deep powder or when carrying heavier loads.

SIZE	22 in	25 in
SKU	13637	13636
DIMENSIONS	20 in 56 in 8 in 22 in	20 in 64 in 8 in 25 in
WEIGHT PER PAIR	1642 g (57.9 oz)	1786 g (63 oz)
BINDING TYPE	Paraglide™	
DECK MATERIAL	Polypropylene	
FRAME MATERIAL	Martensitic Steel	
LOAD W/O TAILS	Up to 80 kilos (Up to 180 lbs )	54 - 95 kilos (120 - 210 lbs )



Charcoal



Bone

## Evo™ Explore Snowshoes

**Durable, comfortable performance for flat and rolling terrain.**

- **Reliable Traction:** Steel crampons and traction rails provide a secure and lasting grip.
- **Durable:** Strong injection-molded UniBody™ deck gives just the right amount of flex.
- **Paradigm™ Binding:** The trifecta of durable performance, secure comfort and easy repairability, with stretch mesh that cradles your feet for a pressure-point-free hold.
- **Uphill Efficiency:** Ergo™ Televators reduce fatigue and increase traction on the steeps with an ergonomic design that engages with a flick of a pole grip.
- **All-Condition Adaptability:** Attachment points for 6-inch (15-cm) Modular Flotation tails (sold separately), which provide on-demand flotation for deep powder or when carrying heavier loads.

<b>SIZE</b>	<b>22 in</b>
<b>SKU</b>	13918
<b>DIMENSIONS</b>	20 in 56 in 8 in 22 in
<b>WEIGHT PER PAIR</b>	1712 g (60 oz)
<b>BINDING TYPE</b>	Paradigm™
<b>DECK MATERIAL</b>	Polypropylene
<b>FRAME MATERIAL</b>	Martensitic Steel
<b>LOAD W/O TAILS</b>	Up to 80 kilos (Up to 180 lbs )

## Women's Evo™ Explore Snowshoes

**Comfortable durability for smaller shoe sizes on flat and rolling trails.**

- **Reliable Traction:** Steel crampons and traction rails provide a secure and lasting grip.
- **Durable:** Strong injection-molded UniBody™ deck gives just the right amount of flex.
- **Women's Paradigm™ Binding:** The trifecta of durable performance, secure comfort and easy repairability, with stretch mesh that cradles your feet for a pressure-point-free hold and straps sized for smaller footwear.
- **Uphill Efficiency:** Ergo™ Televators reduce fatigue and increase traction on the steeps with an ergonomic design that engages with a flick of a pole grip.
- **All-Condition Adaptability:** Attachment points for 6-inch (15-cm) Modular Flotation tails (sold separately), which provide on-demand flotation for deep powder or when carrying heavier loads.

<b>SIZE</b>	<b>22 in</b>
<b>SKU</b>	13919
<b>DIMENSIONS</b>	20 in 56 in 8 in 22 in
<b>WEIGHT PER PAIR</b>	1695 g (60 oz)
<b>BINDING TYPE</b>	Paradigm™
<b>DECK MATERIAL</b>	Polypropylene
<b>FRAME MATERIAL</b>	Martensitic Steel
<b>LOAD W/O TAILS</b>	Up to 80 kilos (Up to 180 lbs )



Iron



Midnight



Midnight

Ranger



## Evo™ Trail Snowshoes

Easy to use, durable and comfortable for flat trails or rolling hills.

- **Reliable Traction:** Steel crampons and traction rails provide a secure and lasting grip.
- **All-Day Comfort:** Paraglide™ binding stretch mesh hugs feet securely and is compatible with nearly any footwear, from light hikers to snowboard boots.
- **Easy to Use:** Glove-friendly binding straps and buckle tabs make getting in and out quick and simple.
- **Durable:** Strong injection-molded UniBody™ deck gives just the right amount of flex.
- **Uphill Efficiency:** Ergo™ Televators reduce fatigue and increase traction on the steepes, with an ergonomic design that engages with a flick of a pole grip.
- **All-Condition Adaptability:** Attachment points for 6-inch (15-cm) modular flotation tails (sold separately), which provide on-demand flotation for deep powder or when carrying heavier loads.

SIZE	22 in
SKU	13631, 13633, 13632
DIMENSIONS	20 in 56 in 8 in 22 in
WEIGHT PER PAIR	1712 g (60.4 oz)
BINDING TYPE	Paraglide™
DECK MATERIAL	Polypropylene
FRAME MATERIAL	Martensitic Steel
LOAD W/O TAILS	Up to 80 kilos (Up to 180 lbs )

## Evo™ Trail Snowshoe Kit

Everything you need in one: snowshoes, poles, and a full-featured carry bag.

- **All-in-One Kit:** Perfect for spontaneous winter adventures and family recreation.
- **Evo Trail Snowshoes:** Durable, proven design with steel traction and Televator heel risers that provides reliable grip and uphill ease while easy-to-use Paraglide™ bindings offer all-day comfort and near-universal footwear compatibility.
- **DynaLock™ Trail Poles:** Two-section aluminum poles with easy, secure DynaLock adjustability and comfortable, ergonomic grips.
- **Carry/Storage Pack:** Built with rugged coated nylon panels to resist abrasion; wide-mouth roll-top for easy access to contents.
- **Added Features:** Removable foam seat, internal zippered pocket, hydration compatibility, and carry loops for pole attachments.

SIZE	22 in
SKU	13642
DIMENSIONS	20 in 56 in 11 in 22 in
WEIGHT PER PAIR	2752 g (97.1 oz)
BINDING TYPE	Paraglide™
DECK MATERIAL	Polypropylene
FRAME MATERIAL	Martensitic Steel
LOAD W/O TAILS	Up to 80 kilos (Up to 180 lbs )



Dino Green



Purple Power

## Tyker™ Kids Snowshoes

**Durable, easy-to-use snowshoes for kids.**

- **Kid-Friendly Bindings:** These secure bindings are designed for smaller, mitten-clad hands and can be used on most any footwear.
- **Parent-Friendly Traction:** Molded traction bars take the place of steel to add safety without compromising essential traction.
- **Adaptable:** Fits kids' shoe sizes 7.5–13.5 and adult sizes 1–4.5 (Men's), 24-34 EU.

<b>SIZE</b>	<b>17 in</b>
<b>SKU</b>	10623, 10622
<b>DIMENSIONS</b>	16.5 x 43 x 9 cm (6.5 x 17 x 3.5 in)
<b>WEIGHT PER PAIR</b>	930 g (32.8 oz)
<b>BINDING TYPE</b>	Tyker
<b>DECK MATERIAL</b>	Polypropylene
<b>FRAME MATERIAL</b>	Polypropylene
<b>LOAD W/O TAILS</b>	Up to 41 kilos (Up to 90 lbs)



Assorted

## Snowshoe Rental Maintenance Kit

**Added depth in the most consumed items in rental programs.**

- **Includes:** (12) 12" Classic straps, (32) standard strap keepers, (12) clevis pin assemblies.

<b>SIZE</b>	<b>One Size</b>
<b>SKU</b>	03677
<b>DIMENSIONS</b>	
<b>WEIGHT PER PAIR</b>	
<b>BINDING TYPE</b>	
<b>DECK MATERIAL</b>	
<b>FRAME MATERIAL</b>	
<b>LOAD W/O TAILS</b>	

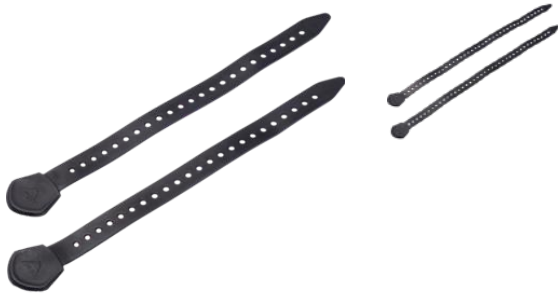

Black



Gray

## Classic Snowshoe Strap Kit

Replacement straps for PosiLock™ bindings (not PosiLock AT) and all pre-2010 snowshoe bindings.

- **Two Sizes:** Available in 12-in. (30-cm) and 18-in. (46-cm) length options.
- **Includes:** (2) replacement straps.

SIZE	12 in	18 in
SKU	07587	07588
DIMENSIONS	30 x 0.25 cm (0.7 x 12 x 0.1 in)	46 x 0.25 cm (0.7 x 18 x 0.1 in)
WEIGHT	5.67 g (0.2 oz)	9.07 g (0.32 oz)

## Paragon™ / PosiLock™ Snowshoe Strap Kit

Replacement straps for Paragon binding heel straps and PosiLock AT binding straps.

- **Two Sizes:** Available in 14-in. (35.5-cm) and 18-in. (46-cm) length options.
- **Includes:** (2) replacement straps.

SIZE	14 in	18 in
SKU	13308	13309
DIMENSIONS	2.5 x 36 x 0.5 cm (1 x 14 x 0.2 in)	2.5 x 46 x 0.5 cm (1 x 18 x 0.2 in)
WEIGHT	57 g (0.5 oz)	65 g (1 oz)



Black



Assorted

## Snowshoe Bag

Holds 1 pair of snowshoes up to 25 in. (64 cm), trekking poles and accessories.

- **Accommodates:** One pair of snowshoes up to 25 in. (64 cm) plus internal sleeve for a pair of Modular Flotation Tails.
- **Pole Compatible:** External hook and loop tabs carry one pair of snowshoe poles for added convenience.
- **Ventilated:** Mesh panel and drain grommet maximize ventilation for long-term storage.
- **Easy-Carry:** Hand and shoulder straps offer multiple carrying options.

SIZE	One Size
SKU	14156
DIMENSIONS	22 x 67 x 15 cm (9 x 26 x 6 in)
WEIGHT	464 g (16 oz)

## Snowshoe Maintenance Kit

Field maintenance kit for all MSR snowshoe bindings and Lighting™ deck rivets.

- **Includes:** Clevis pin assembly: (2) clevis pins, (2) split rings, (2) washers; (5) strap retainers; rivet field repair hardware: (1) screw, (1) lock nut.

SIZE	One Size
SKU	13756
DIMENSIONS	12.5 x 12.5 x 1.3 cm (5 x 5 x 0.5 in)
WEIGHT	60 g (2 oz)



Black

## Snowshoe Standard Strap Keepers

Compatible with all current MSR snowshoe bindings.

- **Includes:** (8) strap keepers.

<b>SIZE</b>	<b>One Size</b>
<b>SKU</b>	03652
<b>DIMENSIONS</b>	
<b>WEIGHT</b>	85 g (3 oz)



Charcoal

## Snowshoe Carry Pack

**Rugged, fully featured snowshoe carry/storage pack that doubles as a daypack.**

- **Rugged:** Coated nylon panels stand up to abrasion from snowshoes carried inside or out.
- **Easy Access:** Hydration-compatible pack with wide-mouth roll top.
- **Fully Featured:** Removable foam seat; internal zippered pocket; loops for pole attachment.
- **Fits:** Fits: 22 in (56 cm) snowshoes carried inside. 22 in (56 cm) – 30 in (76 cm) snowshoes strapped to outside. Poles collapsed: 24.5 in (62.2 cm) – 31.5 in (80 cm).

<b>SIZE</b>	<b>19 L (PFAS)</b>
<b>SKU</b>	11363
<b>DIMENSIONS</b>	25.5 x 53.5 x 13 cm (10 x 21 x 5 in)
<b>WEIGHT</b>	431.95 g (15.25 oz)



Carbon



Steel Gray

## DynaLock™ Ascent Carbon Backcountry Poles

Ultralight carbon fiber combines with ultimate packability for fast-and-light winter adventures.

- **Ultralight:** Ideal for fast-and-light snowshoeing, mountaineering and splitboarding.
- Kevlar®-reinforced carbon fiber.
- Quick-deploy, folding design.
- EVA foam grip, plus lower sidehilling grip.
- Trekking baskets included.

SIZE	120-140 cm	100-120 cm
SKU	10237	10236
DIMENSIONS	5 x 140 x 7.6 cm (2 x 55 x 3 in)	5 x 120 x 7.6 cm (2 x 47 x 3 in)
WEIGHT	496 g (17.5 oz)	471 g (16.6 oz)
COLLAPSED LENGTH	44.5 cm (17.5 in)	36.2 cm (14.25 in)

## DynaLock™ Explore 3-Section Backcountry Poles

Full aluminum strength and 3-section packability for snowshoeing and mountaineering in variable and rugged terrain.

- **Compact:** Excellent versatility for local and distant snowshoeing and mountaineering trips.
- Light, high-strength 7075 aluminum lower sections for increased durability.
- Extended EVA foam grip.
- Trekking baskets included.

SIZE	64-140 cm
SKU	10238
DIMENSIONS	5 x 140 x 7.6 cm (2 x 55 x 3 in)
WEIGHT	552 g (19.5 oz)
COLLAPSED LENGTH	62.2 cm (24.5 in)



White

## DynaLock™ Trail Backcountry Poles

**Two-section aluminum construction for snowshoers, winter hikers and skiers who demand simplicity and maximum durability.**







- **Strong:** The simple and durable choice for casual snowshoers and winter hikers.
- Light two-piece design.
- Ergonomic grip and adjustable strap.
- Trekking baskets included.





<b>SIZE</b>	<b>80-140 cm</b>
<b>SKU</b>	10239
<b>DIMENSIONS</b>	5 x 140 x 6.4 cm (2 x 55 x 2.5 in)
<b>WEIGHT</b>	592 g (21 oz)
<b>COLLAPSED LENGTH</b>	80.0 cm (31.5 in)







**MSR® WINTER SPECIFICATIONS**





**SNOWSHOES**





**MADE IN IRELAND**

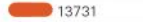



<b>LIGHTNING™ ASCENT</b>	<b>NAME</b>	<b>COLOR / SKU</b>	<b>SIZE</b>	<b>WEIGHT PER PAIR</b>	<b>LOAD W/O TAILS</b>	<b>COMPATIBLE TAILS</b>
	LIGHTNING™ ASCENT M 30	 13078 13081	76 cm (30 in)	2218 g (4 lb 14 oz)	Up to 127 kg (280 lb)	LIGHTNING
	LIGHTNING™ ASCENT M 25	 13077 13080	64 cm (25 in)	1946 g (4 lb 5 oz)	Up to 100 kg (220 lb)	LIGHTNING
	LIGHTNING™ ASCENT M 22	 13076 13079	56 cm (22 in)	1874 g (4 lb 2 oz)	Up to 80 kg (180 lb)	LIGHTNING
	LIGHTNING™ ASCENT W 25	 13083 13085	64 cm (25 in)	1812 g (4 lb)	Up to 95 kg (210 lb)	LIGHTNING
	LIGHTNING™ ASCENT W 22	 13082 13084	56 cm (22 in)	1740 g (3 lb 13 oz)	Up to 80 kg (180 lb)	LIGHTNING









<b>REVO™ ASCENT</b>	<b>NAME</b>	<b>COLOR / SKU</b>	<b>SIZE</b>	<b>WEIGHT PER PAIR</b>	<b>LOAD W/O TAILS</b>	<b>COMPATIBLE TAILS</b>
	REVO™ ASCENT M 25	 13093 13244	64 cm (25 in)	2144 g (4 lb 12 oz)	Up to 100 kg (220 lb)	REVO
	REVO™ ASCENT M 22	 13092 13243	56 cm (22 in)	2026 g (4 lb 7 oz)	Up to 80 kg (180 lb)	REVO
	REVO™ ASCENT W 25	 13095	64 cm (25 in)	2059 g (4 lb 9 oz)	Up to 95 kg (210 lb)	REVO
	REVO™ ASCENT W 22	 13094	56 cm (22 in)	1909 g (4 lb 3 oz)	Up to 80 kg (180 lb)	REVO





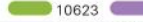

<b>LIGHTNING™ EXPLORE</b>	<b>NAME</b>	<b>COLOR / SKU</b>	<b>SIZE</b>	<b>WEIGHT PER PAIR</b>	<b>LOAD W/O TAILS</b>	<b>COMPATIBLE TAILS</b>
	LIGHTNING™ EXPLORE M 30	 13725	76 cm (30 in)	1960 g (4 lb 5 oz)	Up to 127 kg (280 lb)	LIGHTNING
	LIGHTNING™ EXPLORE M 25	 13726	64 cm (25 in)	1689 g (3 lb 12 oz)	Up to 100 kg (220 lb)	LIGHTNING
	LIGHTNING™ EXPLORE M 22	 13727	56 cm (22 in)	1612 g (3 lb 9 oz)	Up to 80 kg (180 lb)	LIGHTNING
	LIGHTNING™ EXPLORE W 25	 13728	64 cm (25 in)	1571 g (3 lb 7 oz)	Up to 95 kg (210 lb)	LIGHTNING
	LIGHTNING™ EXPLORE W 22	 13729	56 cm (22 in)	1537 g (3 lb 6 oz)	Up to 80 kg (180 lb)	LIGHTNING

<b>REVO™ EXPLORE</b>	<b>NAME</b>	<b>COLOR / SKU</b>	<b>SIZE</b>	<b>WEIGHT PER PAIR</b>	<b>LOAD W/O TAILS</b>	<b>COMPATIBLE TAILS</b>
	REVO™ EXPLORE M 25	 13730	64 cm (25 in)	1888 g (4 lb 3 oz)	Up to 100 kg (220 lb)	REVO
	REVO™ EXPLORE M 22	 13731	56 cm (22 in)	1761 g (3 lb 14 oz)	Up to 80 kg (180 lb)	REVO
	REVO™ EXPLORE W 25	 13732	64 cm (25 in)	1793 g (3 lb 15 oz)	Up to 95 kg (210 lb)	REVO
	REVO™ EXPLORE W 22	 13733	56 cm (22 in)	1657 g (3 lb 10 oz)	Up to 80 kg (180 lb)	REVO

<b>LIGHTNING™ TRAIL</b>	<b>NAME</b>	<b>COLOR / SKU</b>	<b>SIZE</b>	<b>WEIGHT PER PAIR</b>	<b>LOAD W/O TAILS</b>	<b>COMPATIBLE TAILS</b>
	LIGHTNING™ TRAIL M 25	 13638	64 cm (25 in)	1659 g (3 lb 11 oz)	Up to 100 kg (220 lb)	LIGHTNING
	LIGHTNING™ TRAIL M 22	 13639	56 cm (22 in)	1593 g (3 lb 8 oz)	Up to 80 kg (180 lb)	LIGHTNING
	LIGHTNING™ TRAIL W 25	 13640	64 cm (25 in)	1565 g (3 lb 7 oz)	Up to 95 kg (210 lb)	LIGHTNING
	LIGHTNING™ TRAIL W 22	 13641	56 cm (22 in)	1533 g (3 lb 14 oz)	Up to 80 kg (180 lb)	LIGHTNING

<b>REVO™ TRAIL</b>	<b>NAME</b>	<b>COLOR / SKU</b>	<b>SIZE</b>	<b>WEIGHT PER PAIR</b>	<b>LOAD W/O TAILS</b>	<b>COMPATIBLE TAILS</b>
	REVO™ TRAIL M 25	 13634	64 cm (25 in)	1834 g (4 lb 1 oz)	Up to 100 kg (220 lb)	REVO
	REVO™ TRAIL M 22	 13635	56 cm (22 in)	1707 g (3 lb 12 oz)	Up to 80 kg (180 lb)	REVO
	REVO™ TRAIL W 25	 13636	64 cm (25 in)	1786 g (3 lb 7 oz)	Up to 95 kg (210 lb)	REVO
	REVO™ TRAIL W 22	 13637	56 cm (22 in)	1642 g (3 lb 6 oz)	Up to 80 kg (180 lb)	REVO

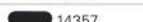
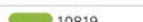
<b>EVO™/YOUTH</b>	<b>NAME</b>	<b>COLOR / SKU</b>	<b>SIZE</b>	<b>WEIGHT PER PAIR</b>	<b>LOAD W/O TAILS</b>	<b>COMPATIBLE TAILS</b>
	EVO™ TRAIL	 13633  13632  13631	56 cm (22 in)	1712 g (3 lb 12 oz)	Up to 80 kg (180 lb)	EVO
	EVO™ EXPLORE M	 13918	56 cm (22 in)	1712 g (3 lb 12 oz)	Up to 80 kg (180 lb)	EVO
	EVO™ EXPLORE W	 13919	56 cm (22 in)	1695 g (3 lb 12 oz)	Up to 80 kg (180 lb)	EVO
	TYKER™	 10623  10622	43 cm (17 in)	930 g (2 lb 1 oz)	Up to 41 kg (90 lb)	

<b>RENTALS</b>	<b>NAME</b>	<b>COLOR / SKU</b>	<b>SIZE</b>	<b>WEIGHT PER PAIR</b>	<b>LOAD W/O TAILS</b>	<b>COMPATIBLE TAILS</b>
	LIGHTNING™ ASCENT M 25	 11586	64 cm (25 in)	1946 g (4 lb 5 oz)	Up to 100 kg (220 lb)	LIGHTNING
	LIGHTNING™ ASCENT W 22	 11588	56 cm (22 in)	1704 g (3 lb 13 oz)	Up to 80 kg (180 lb)	LIGHTNING
	EVO™ ASCENT	 06031	56 cm (22 in)	1776 g (3 lb 15 oz)	Up to 80 kg (180 lb)	EVO
	EVO™ TRAIL	 13643	56 cm (22 in)	1712 g (3 lb 12 oz)	Up to 80 kg (180 lb)	EVO
	EVO™ EXPLORE M	 14357	56 cm (22 in)	1712 g (3 lb 12 oz)	Up to 80 kg (180 lb)	EVO
	TYKER™	 10819	43 cm (17 in)	930 g (2 lb 1 oz)	Up to 41 kg (90 lb)	
	EVO™ TAIL	 06036	15.2 cm (6 in)	346 g (12 oz)		

<b>TAILS</b>	<b>NAME</b>	<b>SKU</b>	<b>SIZE</b>	<b>WEIGHT PER PAIR</b>
	LIGHTNING™ TAIL	05648	12.7 cm (5 in)	255 g (9 oz)
	REVO™ TAIL	05649	12.7 cm (5 in)	351 g (12.4 oz)
	EVO™ TAIL	05650	15.2 cm (6 in)	340 g (12 oz)

**POLES**

**MADE IN TAIWAN**

<b>NAME</b>	<b>SKU</b>	<b>PACKED LENGTH</b>	<b>ADJUSTABLE LENGTH</b>	<b>WEIGHT PER PAIR</b>	
	DYNALOCK™ ASCENT CARBON SM	10236	36.2 cm (14.25 in)	100-120 cm	471 g (16.6 oz)
	DYNALOCK™ ASCENT CARBON LG	10237	44.5 cm (17.5 in)	120-140 cm	496 g (17.5 oz)
	DYNALOCK™ EXPLORE	10238	65 cm (25 in)	100-140 cm	552 g (19.5 oz)
	DYNALOCK™ TRAIL	10239	81 cm (31.5 in)	100-140 cm	592 g (21 oz)

**SNOWSHOE KITS**

**ASSEMBLED IN IRELAND**

<b>NAME</b>	<b>SKU</b>	<b>PACKED LENGTH</b>	<b>ADJUSTABLE LENGTH</b>	<b>KIT WEIGHT</b>	<b>PACK CAPACITY</b>	
	EVO™ TRAIL SNOWSHOE KIT	13642	81 cm (31.5 in)	100-140 cm	2752 g (6 lb 1 oz)	19 L

platypus®



**VERSATILE PRODUCTS  
THAT SIMPLIFY HYDRATION**

# 2026 PLATYPUS | LINE PLAN



FILTRATION

€€€

€

  
DAYCAP™  
IN-BOTTLE FILTER

  
QUICKDRAW™ FILTER

  
QUICKDRAW™  
1L FILTER SYSTEM

  
QUICKDRAW™  
2L FILTER SYSTEM

  
QUICKDRAW™  
3L GRAVITY  
FILTER SYSTEM

  
GRAVITYWORKS™  
FILTER SYSTEM 4.0L

  
GRAVITYWORKS™  
FILTER SYSTEM 6.0L

**BOTTLE**

**SQUEEZE**

**GRAVITY**

- CAPACITY +

# 2026 PLATYPUS | LINE PLAN

## RESERVOIRS & BOTTLES

€€€

**BIG ZIP™ EVO RESERVOIR**  
1.5L / 2.0L / 3.0L



**HOSER™ RESERVOIR**  
1.0L / 2.0L / 3.0L



**PLATY® 2.0L BOTTLE**



**PLATYPRESERVE™**



**SOFTBOTTLE™ 1.0L**

€

- CAPACITY +

# MEET THE EXPANDED QUICKDRAW™ FAMILY

## ONE FILTER TO DO IT ALL

Build a system that meets your needs with the QuickDraw's seamless compatibility with three different QuickDraw reservoirs, Platypus bottles, and all 28mm plastic bottles—like smartwater®. It's the ultimate multisport water filter.

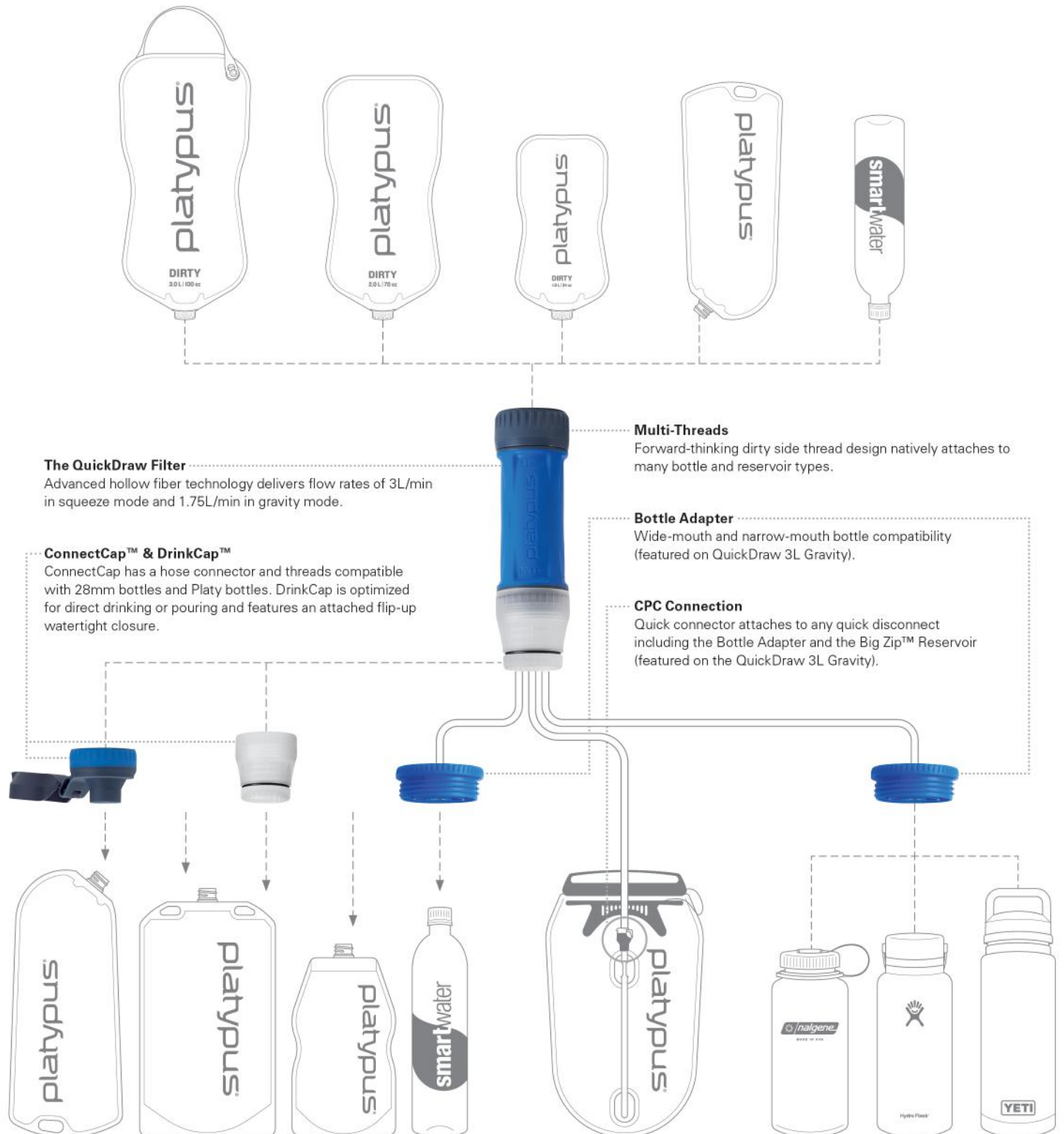

# QUICKDRAW 3L GRAVITY

The QuickDraw 3L Gravity is faster to deploy and easier to use than any other gravity filter system. With a higher capacity, more accessories, and the same forward-thinking QuickDraw modular design it has the highest multi-use potential of any QuickDraw filter system.

## A Better Strap

When attached, the TPE-molded strap is flexible and sturdy for hanging and carrying and will never be packed up wet. When removed, the minimalist attachment posts are unnoticeable when using in squeeze mode.

## Premium Reservoir

Proprietary tri-layer construction technique is guaranteed free of plastic taste and delivers expedition-worthy durability.

## Direct-to-Reservoir Connection

Direct connection to Dirty reservoir eliminates air blockage for increased flow speed.

## ConnectCap™

ConnectCap has hose attachment point and threads that screw directly to 28mm bottles and Platy Bottles.



## CPC Connector

Quick connector securely clicks into Bottle Adapter, a Big Zip™ Hydration Reservoir or any quick disconnect.

## Bottle Adapter

Provides leak-free compatibility with a wide range of bottles for use as clean water storage.

## PRODUCT FEATURES



### TWO CLEANING METHODS

Shake-to-clean and tool-free backflush methods effectively maintain fast flow rates throughout a trip and into the next one.



### TESTED FOR REAL WORLD USE

We use the rigorous P231 testing protocol — a 10-day process subjecting the filter to clear and worst-case water — to ensure its safety and long-lasting performance.

### INTEGRITY CHECK

A simple integrity check that can be easily performed on-trail adds backcountry safety by allowing users to know if their filter has been compromised from being dropped or frozen.



### INDUSTRY-LEADING RESERVOIRS

Designed for fast and easy filling, built for rugged use and guaranteed free of plastic taste, the QuickDraw reservoirs are in a league of their own. It's the Platy standard.





Blue



Green



Orange



Pink

## QuickDraw™ Filter

**Compact, fast-flowing and compatible with a wide variety of bottles and reservoirs, the QuickDraw is the best water filter for your personalized filtration system.**

- **Combine & Customize:** Thread design on the Dirty side and the ConnectCap™ provide seamless compatibility with a wide variety of bottles and reservoirs for easy adaptability.
- **Fast Flowing:** 3 liters per minute with squeeze pressure and 1.75 liters per minute in a gravity setup.
- **Ultralight:** Weighing just 2.4 oz (69 g), it's a perfect foundation for a customized ultralight water filter system.
- **Easy Cleaning:** Two simple cleaning methods—shake-to-clean and a tool-free backflush—remove particulates and maintain fast flow rates.
- **Safe & Effective:** Each filter is individually tested to ensure it meets all EPA & NSF guidelines for the removal of 99.9999% of bacteria and 99.9% of protozoa (Includes Giardia, Cryptosporidium, E. coli, Salmonella and Cholera).
- **Integrity Test:** Determine if your filter has been compromised from a fall or freezing by performing a simple integrity test.
- **Includes:** Dirty-side cap, DrinkCap and ConnectCap™.

SIZE	One Size
SKU	11695, 13852, 13851, 13853
DIMENSIONS	4.6 x 4.6 x 12.7 cm (1.8 x 1.8 x 5 in)
WEIGHT	69 g (2.4 oz)
FILTER MEDIA	Hollow Fiber
FILTER PORE SIZE	0.2
FLOW RATE	3 L/min
CARTRIDGE LIFE	1000 L



Blue



Blue

### QuickDraw™ 1L Filter System

With a premium 1L reservoir, a fast flow rate and an ultralight design that allows for seamless adaptability to numerous dirty reservoirs, the QuickDraw is the best personal squeeze filter system available.

- **Fast Flowing:** 3 liters per minute with squeeze pressure prevents extended stops and keeps you moving.
- **Ultralight:** The whole system weighs just 3.3 oz (95 g), delivering advanced water filtration with a minimal weight tax.
- **Easy Cleaning:** Two simple cleaning methods—shake-to-clean and a tool-free backflush—remove particulates and maintain fast flow rates.
- **Combine & Customize:** Thread design on the dirty side provides seamless compatibility with a wide variety of dirty reservoirs to allow your system to be customized.
- **Safe & Effective:** Each filter is individually tested to ensure it meets all EPA & NSF guidelines for the removal of 99.9999% of bacteria and 99.9% of protozoa. (Includes Giardia, Cryptosporidium, E. coli, Salmonella and Cholera.).
- **Integrity Test:** Determine if your filter has been compromised from a fall or freezing by performing a simple integrity test.
- **Includes:** 1L QuickDraw reservoir, dirty-side cap, DrinkCap and ConnectCap™.

SIZE	One Size
SKU	13903
DIMENSIONS	12.7 x 7.6 x 7.6 cm (5 x 3 x 3 in)
WEIGHT	95 g (3.3 oz)
FILTER MEDIA	Hollow Fiber
FILTER PORE SIZE	0.2
FLOW RATE	3 L/min
CARTRIDGE LIFE	1000 L

### QuickDraw™ 2L Filter System

With a higher storage capacity and the multi-reservoir compatibility of the ConnectCap, the QuickDraw 2L brings more flexibility to ultralight pursuits.

- **Premium Reservoir:** Included 2L reservoir is durable and free of plastic taste thanks to our proprietary tri-layer film construction.
- **Combine & Customize:** The ConnectCap™ delivers compatibility with common 28mm plastic bottles and Platy bottles, while the hose fitted with a quick connector allows direct filtering to quick disconnect-fitted reservoirs like the BigZip™.
- **Fast Flowing:** 3 liters per minute with squeeze pressure and 1.75 liters per minute in a gravity setup.
- **Ultralight:** Weighing just 5.7 oz (161 g), it keeps things ultralight while increasing water capacity.
- **Safe & Effective:** Each filter is individually tested to ensure it meets all EPA & NSF guidelines for the removal of 99.9999% of bacteria and 99.9% of protozoa. (Includes Giardia, Cryptosporidium, E. coli, Salmonella and Cholera.).
- **Integrity Test:** Determine if your filter has been compromised from a fall or freezing by performing a simple integrity test.
- **Includes:** 2L QuickDraw reservoir, dirty-side cap, ConnectCap™, and short hose with a quick connector.

SIZE	One Size
SKU	11694
DIMENSIONS	18.8 x 7.6 x 7.1 cm (7.4 x 3 x 2.8 in)
WEIGHT	127 g (4.5 oz)
FILTER MEDIA	Hollow Fiber
FILTER PORE SIZE	0.2
FLOW RATE	3 L/min
CARTRIDGE LIFE	1000 L



Blue



White



## QuickDraw™ 3L Gravity Filter System

Ideal for fast-moving groups, the QuickDraw 3L Gravity delivers the same fast, simple and ultra-versatile performance the QuickDraw lineup is known for in an effortless gravity-powered design.

- **Combine & Customize:** Accessories like the ConnectCap, a hose with a quick connector and the wide and narrow-mouth compatible Bottle Adapter allow the system to be tailored and optimized.
- **Premium Reservoir:** 3L reservoir is taste-free and durable thanks to our proven construction technique and features a detachable hang strap to allow both gravity and squeeze filtering.
- **Fast Flowing:** 1.75 liters per minute in a gravity setup and 3 liters per minute with squeeze pressure.
- **Ultralight:** Weighing just 8.2 oz (233 g) it supports groups with clean water without weighing them down.
- **Integrity Test:** Determine if your filter has been compromised from a fall or freezing by performing a simple integrity test.
- **Safe & Effective:** Each filter is individually tested to ensure it meets all EPA & NSF guidelines for the removal of 99.9999% of bacteria and 99.9% of protozoa. (Includes Giardia, Cryptosporidium, E. coli, Salmonella and Cholera.)
- **Includes:** 3L QuickDraw reservoir, dirty-side cap, ConnectCap™, Bottle Adapter, long hose with a quick connector, shutoff clamp and storage bag.

SIZE	One Size
SKU	11693
DIMENSIONS	24.1 x 9.9 x 8.1 cm (9.5 x 3.9 x 3.2 in)
WEIGHT	233 g (8.2 oz)
FILTER MEDIA	Hollow Fiber
FILTER PORE SIZE	0.2
FLOW RATE	3 L/min
CARTRIDGE LIFE	1000 L

## GravityWorks™ Water Filter System

High-capacity, pump-free filtration for groups and basecamps. Our largest, most group-ready system easily provides filtered water for drinking, washing up, cooking, and cleaning. Available in 4.0L and 6.0L sizes.

- **Group-ready:** 12 liter (6.0L filtered + 6.0L unfiltered) or 8 liter (4.0L filtered + 4.0L unfiltered) total capacity easily supplies water for large groups.
- **Includes:** Dirty reservoir, clean reservoir, hollow fiber microfilter, hoses, shutoff clamp, and a storage sack.

SIZE	4 L	6 L
SKU	14240	14241
DIMENSIONS	20 x 38 x 10 cm (8 x 15 x 4 in)	25 x 49.5 x 10 cm (10 x 19.5 x 4 in)
WEIGHT	456 g (16 oz)	481 g (17 oz)
FILTER MEDIA	Hollow Fiber	
FILTER PORE SIZE	0.2	
FLOW RATE	1.75 L/min	
CARTRIDGE LIFE	1500 L	

# DAYCAP™ IN-BOTTLE FILTER

## SCOOP & DRINK. IT'S THAT EASY.

Transform your favorite wide-mouth water bottle into an effortless scoop-and-drink water filter with the DayCap™. With a premium feel that complements the quality of your bottle, the hollow fiber technology delivers fast-flowing 0.2-micron filtration, so you spend less time worrying about clean hydration and more time enjoying the great outdoors.



HYDRO FLASK®



NALGENE®



YETI® YONDER™



Blue



Clear

## DayCap™ In-Bottle Filter

For when you want to head out with easiest possible water filtration, we engineered the DayCap to seamlessly fit three popular wide-mouth water bottles and turn them into fast, safe and incredibly easy water filters.

- **Multi-compatible:** Optimized to fit Nalgene® wide-mouth bottles, HydroFlask® wide-mouth bottles, and Yeti® Yonder™ bottles.
- **Easy-to-Use Design:** With a drink spout optimized for pulling water through the filter, all you need to do is tip your bottle up like usual and drink.
- **Premium Construction:** TPE mold construction is durable and complements the quality of your bottle.
- **Proven Filtration:** Filtering up to 1 liter per minute, hollow fiber filtration media is the same technology as our most popular and field-proven filters.
- **Easy Cleaning:** Simply shake to clean with it attached to your bottle to break up particulates and restore flow rates.
- **Safe & Effective:** Each filter is individually tested to ensure it meets all EPA & NSF guidelines for the removal of 99.9999% of bacteria and 99.9% of protozoa. (Includes Giardia, Cryptosporidium, E. coli, Salmonella and Cholera.).
- **Expertly Engineered:** Filter detaches with an easy half-turn for cap-only mode; spout shape is optimized for drinking and pouring; semi-flexible carry loop is a sturdy attachment point.

SIZE	One Size
SKU	13878
DIMENSIONS	7.1 x 9.9 x 10.7 cm (2.8 x 3.9 x 4.2 in)
WEIGHT	72 g (2.6 oz)
FILTER MEDIA	Hollow Fiber
FILTER PORE SIZE	0.2
FLOW RATE	1 L/min
CARTRIDGE LIFE	1000 L

## Hoser™ Reservoir

Ultralight, taste-free, with a high flow rate—the Hoser is the perfect minimalist reservoir.

- **High-Flow Bite Valve:** The self-sealing HyFLO™ bite valve delivers a 30% increase in flow rate from the previous Hoser, making it quick and easy to hydrate on the go.
- **Versatile:** Classic threaded port and 1/4" dia. drink tube make it compatible with accessory caps and adapters.
- **Secure:** Integrated hanger and carry loop secure the reservoir in a backpack.
- **Taste-Free & Durable:** Our proprietary tri-layer film uses a rugged thermoplastic polyurethane outer layer and a taste-free polyethylene inner layer.
- **Microbe-Resistant:** Embedded silver-ion protects reservoir from mold and bacteria.

SIZE	1 L	2 L	3 L
SKU	10856	10854	10853
DIMENSIONS	13.5 x 29 x 7 cm (5.2 x 11.5 x 3 in)	15 x 40.5 x 7 cm (6 x 16 x 3 in)	18 x 42 x 7 cm (7 x 16.5 x 3 in)
WEIGHT	91 g (3.2 oz)	102 g (3.6 oz)	109 g (3.8 oz)

**MUST  
HAVE**



Clear

**MUST  
HAVE**



Clear

## Big Zip™ EVO Reservoir

Premium taste-free, high-flow reservoir loaded with features for easy on-the-go hydration. The Big Zip EVO delivers a 50% increased flow rate from the previous Big Zip, making it the fastest-flowing, taste-free reservoir available to backpackers, hikers and mountain bikers.

- **Fast & Easy:** The self-sealing HyFLO™ bite valve, leak-proof shutoff valve and large 5/16" dia. tubing contribute to fast flow and ease of use.
- **Quick Access:** Low-profile shape and high-mount drink tube quick-disconnect make it easy to load/unload.
- **Easy to Fill & Clean:** Wide opening and one-handed grip eases filling and cleaning.
- **Microbe Resistant:** Embedded silver-ion protects reservoir from mold and bacteria.
- **Taste-Free & Durable:** Our proprietary tri-layer film uses a rugged thermoplastic polyurethane outer layer and a taste-free polyethylene inner layer.
- **Quicker Drying:** Semi-rigid baffle helps keep reservoir open, ensuring quicker drying with less fuss.

SIZE	1.5 L	2 L	3 L
SKU	10859	10858	10857
DIMENSIONS	21.6 x 33 x 6.3 cm (8.5 x 13 x 2.5 in)	22.1 x 38.1 x 6.3 cm (8.7 x 15 x 2.5 in)	22.9 x 43.7 x 6.3 cm (9 x 17.2 x 2.5 in)
WEIGHT	160 g (5.6 oz)	171 g (6.0 oz)	184 g (6.5 oz)

## Platy® 2L Bottle

Simple, flexible bottle that is compatible with all threaded Platy products. The original flexible bottle delivers the ultimate in lightweight, portable, and reusable BPA-, BPS- and phthalate-free hydration.

- **Filter Compatible:** Compatible with GravityWorks systems and QuickDraw filters.
- **Versatile:** Accepts any threaded Platypus cap or drink tube.

SIZE	One Size
SKU	07601
DIMENSIONS	19 x 35 x 7 cm (7.5 x 13.8 x 2.8 in)
WEIGHT	36 g (1.3 oz)

MUST  
HAVE



Regal Blue

## PlatyPreserve™

Flexible, glass-free wine bottle preserves the flavor of wine. By providing an air-tight barrier in a flexible design, the PlatyPreserve safeguards the flavor of your wine and offers the perfect solution for transporting it securely.

- **Safe and Light:** Glass-free, flexible and collapsible for go-anywhere convenience.
- **Untainted Flavor:** Food-grade lining is taste-free as well as BPA-, BPS- and phthalate-free.
- **Ergonomic:** Angled spout for easy filling and pouring.

<b>SIZE</b>	<b>One Size</b>
<b>SKU</b>	10968
<b>DIMENSIONS</b>	16 x 26 x 4 cm (6.3 x 10 x 1.6 in)
<b>WEIGHT</b>	24 g (0.8 oz)



Logo



Waves

## SoftBottle™

Our lightest, most compact flexible water bottle holds the water you need to stay hydrated then rolls up to be stowed in the tightest spaces of your pack.

- **Packable:** Flattens and rolls up small enough to pack into pocket when empty.
- **Smart Design:** Contoured shape makes it easy to grip.
- **Versatile:** Available with a Closure Cap — accepts any threaded Platypus lid or drink tube kit.
- **Filter Compatible:** Works with QuickDraw filters.

<b>SIZE</b>	<b>1 L</b>
<b>SKU</b>	11530, 09250
<b>DIMENSIONS</b>	15 x 33 x 4 cm (6 x 13 x 1.6 in)
<b>WEIGHT</b>	35 g (1.2 oz)



Blue

## DayCap™ Replacement Filter

Replacement filter cartridge for the DayCap In-Bottle Filter.

- This replacement filter cartridge is the same high-flow and effective hollow fiber filter that came with your original DayCap In-Bottle Filter.

SIZE	One Size
SKU	13880
DIMENSIONS	3.8 x 3.8 x 9 cm (1.5 x 1.5 x 3.5 in)
WEIGHT	3 g (1 oz)



Blue

## Bite Valve Cover

Sanitary cover for Platypus bite valves keeps off dirt and debris while insulating against freezing.

SIZE	One Size
SKU	11008
DIMENSIONS	2.5 x 3.3 x 4.3 cm (1 x 1.3 x 1.7 in)
WEIGHT	9 g (0.3 oz)



Blue

## Hoser™ Drink Tube Kit

Replaces old Hoser drink tube or converts any threaded-opening Platypus bottle to a reservoir.

- **Includes:** Threaded closure, a ¼" drink tube, a lapel clip, and a fast-flowing HyFLO™ bite valve.

SIZE	One Size
SKU	11009
DIMENSIONS	1.8 x 102 x 2.5 cm (0.7 x 40 x 1 in)
WEIGHT	59 g (2.1 oz)



Clear

## HyFLO™ Bite Valve

A streamlined, one-piece bite valve that offers fast-flowing, self-sealing, leak-free performance.

- Works with all Platypus shutoff valves and ¼-inch tubing.

SIZE	One Size
SKU	11005
DIMENSIONS	2 x 2.3 x 3.6 cm (0.8 x 0.9 x 1.4 in)
WEIGHT	5 g (0.2 oz)



Blue

## Reservoir Cleaning Kit

Keep your hydration reservoir and drink tube fresh and clean with this easy-to-use 2-brush set.

- The broad head brush is designed to scrub the interior nooks and crannies of your reservoir while the thin, coiled brush scours your drink tube for a thorough, good-as-new clean.
- Includes a set of brushes to clean tubes and reservoirs.

<b>SIZE</b>	<b>One Size</b>
<b>SKU</b>	11011
<b>DIMENSIONS</b>	
<b>WEIGHT</b>	93 g (3.3 oz)



Multi

## GravityWorks™ Universal Bottle Adapter

Allows direct filtration into a range of vessels, including threaded and unthreaded wide- and narrow-mouth bottles, reservoir hoses and more.

<b>SIZE</b>	<b>One Size</b>
<b>SKU</b>	06956
<b>DIMENSIONS</b>	4.3 x 9.7 x 4.3 cm (1.7 x 3.7 x 1.7 in)
<b>WEIGHT</b>	57 g (2 oz)



Multi

## GravityWorks™ Push-Pull Cap Adapter

Allows direct filtration into bottles with push-pull caps and drink tubes.

<b>SIZE</b>	<b>One Size</b>
<b>SKU</b>	06955
<b>DIMENSIONS</b>	6.4 x 3 x 3 cm (2.5 x 1.2 x 1.2 in)
<b>WEIGHT</b>	14 g (0.5 oz)



Blue

## GravityWorks™ Filter Cartridge

Replacement filter cartridge for the GravityWorks system.

- This replacement filter for the GravityWorks water filter system is effective down to .2 microns and meets all EPA and NSF guidelines for the removal of 99.9999% of bacteria and 99.9% of protozoa, helping treat water in the backcountry for safe drinking.
- Microfilter lifetime of up to 1,500L, depending on the quality of the water.

<b>SIZE</b>	<b>One Size</b>
<b>SKU</b>	07016
<b>DIMENSIONS</b>	4.6 x 14.7 x 4.6 cm (1.8 x 5.8 x 1.8 in)
<b>WEIGHT</b>	53.4 g (1.9 oz)



Clear



Multi

## GravityWorks™ Replacement Hose Kits

Easily replace old or damaged hoses and parts with these kits for either the 4.0L or 2.0L GravityWorks water filter systems.

- Each kit includes: 1 Clean hose, 1 Dirty hose, a quick-connect fitting and a shut-off clamp.

SIZE	2 L	4 L
SKU	06954	07018
DIMENSIONS	12.5 x 91 x 18 cm (5 x 36 x 7 in)	
WEIGHT	71 g (2.5 oz)	73 g (2.6 oz)

## GravityWorks™ Carbon Element

Helps reduce flavors, odors, and organic compounds from filtered water for the best taste possible.

SIZE	One Size
SKU	06700
DIMENSIONS	3.2 x 5.7 x 3.2 cm (1.25 x 2.25 x 1.25 in)
WEIGHT	33 g (1.16 oz)



Clear

## GravityWorks™ Replacement Reservoirs

Replaces worn reservoirs or expands capacity of existing systems.

- Reservoirs are interchangeable with any GravityWorks system thanks to quick-connect fittings.
- The 2.0L replacement reservoir kit includes (1) Dirty reservoir bag with a quick-disconnect fitting.
- 4.0L and 6.0L replacement reservoir kits include (1) Dirty reservoir with a quick-disconnect fitting and (1) Clean reservoir.

SIZE	2 L	4 L	6 L
SKU	06953	03136	11170
DIMENSIONS	18 x 33 x 10 cm (7 x 13 x 4 in)	20 x 38 x 10 cm (8 x 15 x 4 in)	26 x 49 x 10 cm (10 x 19.5 x 4 in)
WEIGHT	63 g (2.2 oz)	170 g (6 oz)	180 g (6.5 oz)



# WATERPROOF YOUR ADVENTURES

## SIGNATURE TECHNOLOGIES



**RADIO FREQUENCY (RF) WELDED SEAMS**  
Radio frequencies are employed to bond fabric together at the molecular level. This strong, long-lasting, reliably waterproof construction method withstands up to 2x more stress than sewn-and-taped seams, which can fail over time allowing water to pass through the materials.



**DRYSEAL™ CLOSURE**  
Our easy-to-use, dual-strip system amplifies roll-top closure protection while making it intuitive to achieve an optimal seal for the best waterproof protection.



**SEALOCK™ CLOSURE**  
Discreet and easy-to-use dual-track zipper closure seals tight for confident submersible protection.



**CONTINUOUS COMPRESSION**  
Unlike conventional systems that pull against seams, our Continuous Compression system encircles the sack to minimize seam strain, maximizing durability for dependable protection.

## WATER PROTECTION RATINGS



**SPLASHPROOF**  
Protects gear from light rain and splashes.



**WATERPROOF**  
Protects gear from heavy rain and soakings.



**SUBMERSIBLE**  
Protects gear from full water submersion – withstands 1 meter of water for 30 minutes.

## EARTH-FRIENDLY MATERIALS



**PVC-FREE**  
We actively pursue the sourcing of PVC-free alternatives in some of our most popular products. A smaller eco-footprint and premium performance make it a win-win for all concerned.



Black



Black



Brown



Orange



Blue



Yellow

## Pro™ Dry Pack

Our most supportive & comfortable large-capacity waterproof pack for big river running, frequent portaging and worry-free expedition travel, with a heavy-duty suspension system.

- **Waterproof:** Ultra-durable waterproof materials & welded seam construction for confident protection.
- **Full-Length Support:** Full-length framesheet transfers weight to the waist belt for optimal load support.
- **Premium Comfort:** Soft-edged padded shoulder straps, full-length breathable back panel padding, lumbar padding, and padded waist belt ensure comfort when hauling massive loads.
- **Tailored Fit:** Suspension system adjusts between three sizes—S, M, L—to fit torso lengths 17 in, 19 in and 21 in (43 cm, 48 cm and 53 cm).
- **Better Bottom:** Reinforced bathtub bottom delivers the ultimate in durability.
- **Light-Colored Interior:** Eases identification of contents.
- **Streamline-able:** Shoulder straps and waist belt can be removed for a sleek profile.

SIZE	70 L	120 L
SKU	14056, 14057, 14058	14053, 14054, 14055
DIMENSIONS	23 x 44 x 68 cm (9 x 17.5 x 27 in)	32 x 47 x 81 cm (12.5 x 18.5 x 32 in)
WEIGHT	2150 g (76 oz)	2500 g (88 oz)
MATERIALS	Body: 600D 17 oz Polyurethane-Coated Polyester, Bottom/Sides: 400D 20 oz Polyurethane-Coated Nylon	

## Black Canyon™ Dry Pack

Large capacity, suspension system & versatility make it a solid choice for any adventure where dry protection and comfort matter.

- **Waterproof:** Ultra-durable waterproof materials & welded seam construction for confident protection.
- **Balanced Comfort:** A “just right” amount of support subdues moderate loads via padding on shoulder straps, waist belt, back and lumbar areas.
- **Light-Colored Interior:** Eases identification of contents.
- **Tight, Simple Sealing:** DrySeal™ roll-top closure makes it easy and intuitive to achieve an optimal seal and secures with side compression straps.
- **Streamline-able:** Shoulder straps and waist belt can be removed for a sleek profile.

SIZE	65 L	115 L
SKU	14062, 14063, 14064	14059, 14060, 14061
DIMENSIONS	23 x 44 x 64 cm (9 x 17.5 x 25 in)	32 x 47 x 76 cm (12.5 x 18.5 x 30 in)
WEIGHT	1720 g (61 oz)	2100 g (74 oz)
MATERIALS	Body: 600D 17 oz Polyurethane-Coated Polyester, Bottom/Sides: 400D 20 oz Polyurethane-Coated Nylon	

MUST  
HAVE



Black



Blue



Lime

MUST  
HAVE



Heather Blue



Heather Gray



Heather Green

## Bigfork™ Dry Daypack

A simple and highly durable waterproof pack for paddlers with a streamlined mix of features to protect essentials on single-day and overnight adventures.

- **Waterproof:** Ultra-durable waterproof materials & welded seam construction for confident protection.
- **Smartly Minimal:** Front bungee system and lash points make it easy to secure items for quick retrieval or secure the pack to a deck.
- **Light-Colored Interior:** Eases identification of contents.
- **Tight, Simple Sealing:** DrySeal™ roll-top closure makes it easy and intuitive to achieve an optimal seal.
- **Streamline-able:** Padded shoulder straps and webbing waist belt can be removed for a sleek profile.

<b>SIZE</b>	<b>30 L</b>
<b>SKU</b>	14065, 14066, 14067
<b>DIMENSIONS</b>	18 x 30 x 55 cm (7 x 12 x 22 in)
<b>WEIGHT</b>	800 g (28 oz)
<b>MATERIALS</b>	300D 17 oz Polyurethane-Coated Polyester

## Skylake™ Dry Daypack

Perfect for carrying essentials on short excursions on or near the water, this fully waterproof pack rolls up small for take-anywhere convenience.

- **Waterproof:** Ultra-durable waterproof materials & welded seam construction for confident protection.
- **Stowable:** Roll up the pack, clip, and store easily.
- **Expandable Capacity:** Front stretch stash pocket is perfect for stowing items for quick access.
- **Tight, Simple Sealing:** DrySeal™ roll-top closure makes it easy and intuitive to achieve an optimal seal.
- **Streamline-able:** Lightly padded shoulder straps can be removed for a sleek profile.

<b>SIZE</b>	<b>18 L</b>
<b>SKU</b>	14068, 14070, 14069
<b>DIMENSIONS</b>	15 x 25 x 53 cm (6 x 10 x 21 in)
<b>WEIGHT</b>	380 g (13.5 oz)
<b>MATERIALS</b>	250D 6.7 oz Polyurethane-Coated Polyester/Nylon Blend



Black

Brown

Orange

## Pro™ Zip Duffel

For boaters, paddlers and adventure travelers seeking a top-of-the line submersible gear hauler for durable protection in all conditions.

- **Submersible Protection:** Rated to withstand full submersion in 1 meter of water for 30 minutes.
- **Comfortably Portable:** Removable carry handles/shoulder straps with strap keeper offer versatile carry options.
- **Lasting Durability:** Strong polyurethane-coated polyester, an abrasion-resistant bottom, and RF-welded construction provide long-lasting waterproof performance.
- **Easy Access:** Smooth-gliding, high-quality YKK AquaSEAL® waterproof zipper.
- **Easy, Secure Handling:** Four side-haul handles make for easy handling; lash points secure duffel to boats, vehicles, etc.

SIZE	40 L	70 L	100 L
SKU	14071, 14072, 14073	14074, 14075, 14076	14077
DIMENSIONS	28 x 61 x 23 cm (13 x 24 x 9 in)	40 x 71 x 28 cm (15.5 x 28 x 11 in)	48 x 74 x 32 cm (19.2 x 29 x 12.6 in)
WEIGHT	1000 g (35 oz)	1150 g (40.5 oz)	1300 g (46 oz)
MATERIALS	Body: 600D 18 oz Polyurethane Double-Coated Polyester, Bottom/Sides: 400D 24 oz Polyurethane Double-Coated High Tenacity Nylon		



Clear



Heather Blue



Heather Gray

Heather Green

## Map Case

Easy-access, PVC-free protection for maps and more.

- **Waterproof:** Constructed with 100% waterproof materials & welded seams.
- **Versatile:** D-rings for easy gear attachment.
- **Lasting Visibility:** Clear polyurethane resists UV damage.
- **Easy Access:** Waterproof zip closure for quick and easy access.
- **PVC-Free:** Keeps persistent PVCs out of the environment.

SIZE	Medium	Large
SKU	11584	11585
DIMENSIONS	30.0 x 41.0 x 0.25 cm (12 x 16 x 0.1 in)	41.0 x 56.0 x 0.25 cm (16 x 22 x 0.1 in)
WEIGHT	130 g (5.0 oz)	225 g (7.0 oz)
FITS	Maps, charts, and key documents	
MATERIALS	Polyurethane Film, Polypropylene Webbing	





















## E-Case® Protective Case

Ensuring everyday essentials stay dry, these cases deliver submersible protection and have a quick, easy zip opening.

- **Submersible Protection:** Individually tested to IPX7 standard of withstanding full submersion in 1 meter of water for 30 minutes.
- **Full Functionality:** Ultra-clear polyurethane windows allow full functionality of touchscreens, cameras, and voice functions.
- **Easy Security:** SealLock™ zippered seal and rugged RF-welded seams ensure protection from the elements.

SIZE	Small	Medium	Large
SKU	11435, 11434, 11436	11438, 11437, 11439	11440, 11441
DIMENSIONS	11.5 x 18.5 x 0.33 cm (4.5 x 7.3 x 0.12 in)	15.0 x 20.0 x 0.33 cm (6 x 8 x 0.13 in)	17.6 x 24.2 x 0.33 cm (7 x 9.5 x 0.13 in)
WEIGHT	35 g (1.2 oz)	43 g (1.5 oz)	52 g (1.8 oz)
FITS	Most smartphones; larger wallets; small first aid kits	Passport; first aid kit; point- and-shoot camera	Smaller tablets; TSA toiletry kit
MATERIALS	250D 6.7 oz Polyurethane-Coated Polyester/Nylon Blend, Urethane Film		

**PACKS, DUFFELS & DRY CASES**

PACKS	SIZE	COLOR / SKU			WEIGHT	DIMENSIONS (W x L x H)*	VOLUME	PVC-FREE
								
<b>Bigfork™ Dry Daypack</b>	30L	14065	14066	14067	800 g (1 lb 12 oz)	18 x 30 x 55 cm (7 x 12 x 22 in)	30 liters (1831 cu in)	✓
								
<b>Skylake™ Dry Daypack</b>	18L	14068	14070	14069	380 g (13.5 oz)	15 x 25 x 53 cm (6 x 10 x 21 in)	18 liters (1100 cu in)	✓
								
<b>Pro™ Dry Pack</b>	70L	14056	14058	14057	2150 g (4 lb 12 oz)	23 x 44 x 68 cm (9 x 17.5 x 27 in)	70 liters (4270 cu in)	✓
	120L	14053	14055	14054	2500 g (5 lb 8 oz)	32 x 47 x 81 cm (12.5 x 18.5 x 32 in)	120 liters (7320 cu in)	✓
								
<b>Black Canyon™ Dry Pack</b>	65 L	14062	14064	14063	1720 g (3 lb 13 oz)	23 x 44 x 64 cm (9 x 17.5 x 25 in)	65 liters (3960 cu in)	✓
	115 L	14059	14061	14060	2100 g (4 lb 10 oz)	32 x 47 x 76 cm (12.5 x 18.5 x 30 in)	115 liters (7010 cu in)	✓
DUFFELS	SIZE	COLOR / SKU			WEIGHT	DIMENSIONS (W x L x H)*	VOLUME	PVC-FREE
								
<b>Pro™ Zip Duffel</b>	40L	14072	14071	14073	1000 g (2 lb 3 oz)	28 x 61 x 23 cm (11 x 14.5 x 9 in)	40 liters (2400 cu in)	✓
	70L	14075	14074	14076	1150 g (2 lb 8 oz)	40 x 71 x 28 cm (16 x 28 x 11 in)	70 liters (4270 cu in)	✓
	100L		14077		1300 g (2 lb 14 oz)	48 x 74 x 32 cm (19 x 29 x 13 in)	100 liters (6100 cu in)	✓
DRY BAGS	SIZE	COLOR / SKU			WEIGHT	DIMENSIONS (W x L x H)*	VOLUME	PVC-FREE
								
<b>Discovery™ Dry Bag</b>	5L	09638			175 g (6.2 oz)	11 x 17 x 25 cm (4 x 7 x 10 in)	5 liters (305 cu in)	✓
	10L	09642	09645		275 g (10 oz)	13 x 21.5 x 37 cm (5 x 8.5 x 14.5 in)	10 liters (610 cu in)	✓
	20L	09648	09651		390 g (14 oz)	15 x 25 x 45 cm (6 x 10 x 18 in)	20 liters (1220 cu in)	✓
	30L	09654			500 g (1 lb 2 oz)	18 x 30 x 50 cm (7 x 12 x 20 in)	30 liters (1831 cu in)	✓
CASES	SIZE	COLOR / SKU			WEIGHT	DIMENSIONS (W x L)*	INTERNAL DIMENSIONS	PVC-FREE
								
<b>Map Case</b>	Regular	11584			130 g (5 oz)	30 x 41 cm (12 x 16 in)	26 x 37 cm (10 x 14.5 in)	✓
	Large	11585			225 g (7 oz)	41 x 56 cm (16 x 22 in)	38 x 52 cm (14 x 20.5 in)	✓
								
<b>E-Case®</b>	Small	11434	11435	11436	35 g (1.2 oz)	11.5 x 18.5 cm (4.5 x 7.3 in)	9 x 15.5 cm (3.5 x 6.1 in)	✓
	Medium	11437	11438	11439	43 g (1.5 oz)	15 x 20 cm (6 x 8 in)	13 x 19 cm (5.1 x 7.5 in)	✓
	Large	11440		11441	52 g (1.8 oz)	17.6 x 24.2 cm (7 x 9.5 in)	15.3 x 22 cm (6 x 8.7 in)	✓

# PackTowl®

**TOP-TIER  
QUALITY FOR  
NEXT-LEVEL FUN**



# PERSONAL ARTIST SERIES COLLECTION



DESERT AIRE

FLOW

DAYDREAM

ORCA

MYSTIC MOOSE

BALANCE

## Gianna Andrews

There are times where we would prefer to be out in nature, but life keeps us inside. Drawing on personal experience, Gianna's work for PackTowl's Artist Series transports us to where we would prefer to be: immersed in the natural world.

Artist of Desert Aire

## Kristina Wayte Bakke

With her signature blend of energetic lines and expressive brush strokes, Kristina's work for PackTowl's Artist Series captures the world of movement in which all outdoor adventurers live.

Artist of Flow and Daydream

## Shogo Ota

With an unmistakable aesthetic informed by the art found in tiny everyday details, Shogo highlights the PNW he calls home for PackTowl's Artist Series and evokes the fun and vibrant adventure lifestyle it inspires.

Artist of Orca and Mystic Moose

## Emily Kelley

For PackTowl's Artist Series, Emily contemplated the many places a towel will go and the human experiences it will witness. Her work evokes the essential peace in vulnerability we find when we connect with nature.

Artist of Balance





Desert Aire Print



Daydream Print



Mystic Moose Print



Flow Print



Orca Print



Balance Print

## Personal Artist Series Towel

Our best-selling, ultra-versatile and eco-conscious adventure towel comes in stunning artist prints.

- **Superfast Drying:** Dries 70% faster than comparable cotton towels; hang loop to make it even easier.
- **Sustainably Made:** 50% recycled fabric reduces environmental impact by limiting waste in the textile supply chain.
- **Polygiene®:** Eco-friendly silver-ion odor control keeps towel fresh longer. Trademark owned by PolygieneAB.
- **Artist Collaborations:** Each towel features beautiful artwork from an exceptional artist who's work is inspired by the places that inspire us all.

SIZE	Body
SKU	14231, 14230, 14232, 13872, 13874, 13873
DIMENSIONS	64 x 137 x 0.25 cm (25 x 54 x 0.1 in)
WEIGHT	180 g (6.4 oz)
MATERIALS	80% Polyester, 20% Nylon



Lake Blue



Midnight

## Personal Towel

Our best-selling, ultra-versatile and eco-conscious adventure towel delivers the light, compact, super-absorbent and quick-drying performance to make it the best option for traveling, camping, water sports and everyday gym workouts.

- **Superfast Drying:** Dries 70% faster than comparable cotton towels; hang loop to make it even easier.
- **Sustainably Made:** 50% recycled fabric reduces environmental impact by limiting waste in the textile supply chain.
- **Polygiene®:** Eco-friendly silver-ion odor control keeps towel fresh longer. Trademark owned by PolygieneAB.

SIZE	Face	Hand	Body	Beach
SKU	11680, 11766	11681, 11767	11682, 11768	11683, 11769
DIMENSIONS	25 x 36 x 0.25 cm (10 x 14 x 0.1 in)	42 x 92 x 0.25 cm (16.5 x 36 x 0.1 in)	64 x 137 x 0.25 cm (25 x 54 x 0.1 in)	91 x 150 x 0.25 cm (36 x 59 x 0.1 in)
WEIGHT	20 g (0.7 oz)	80 g (2.9 oz)	180 g (6.4 oz)	280 g (9.7 oz)
MATERIALS	80% Polyester, 20% Nylon			

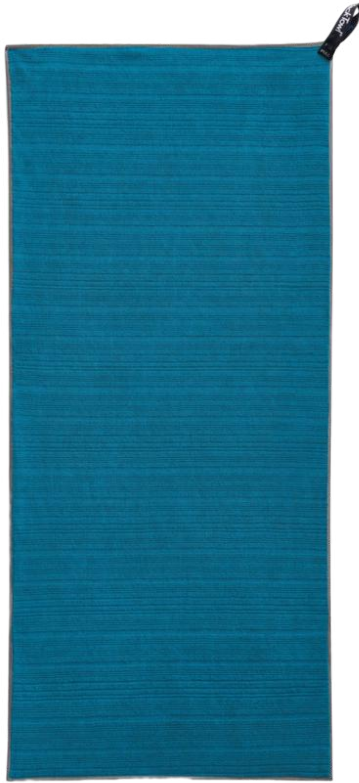

Lake Blue



Midnight



Terracotta

## Luxe Towel

The most eco-conscious and luxurious quick-dry towel out there.

- **Fast Drying:** Dries 30% faster than comparable cotton towels.
- **Recycled Fabric:** 50% recycled fabric reduces environmental impact by limiting waste in the textile supply chain.
- **Polygiene®:** Eco-friendly silver-ion odor control keeps towel fresh longer. Trademark owned by PolygieneAB.

SIZE	Face	Hand	Body	Beach
SKU	11650, 11642, 11654	11651, 11643, 11655	11652, 11644, 11656	11653, 11645, 11657
DIMENSIONS	25 x 36 x 0.25 cm (10 x 14 x 0.1 in)	42 x 92 x 0.25 cm (16.5 x 36 x 0.1 in)	64 x 137 x 0.25 cm (25 x 54 x 0.1 in)	91 x 150 x 0.25 cm (36 x 59 x 0.1 in)
WEIGHT	30 g (1.1 oz)	130 g (4.6 oz)	300 g (10.4 oz)	460 g (16 oz)
MATERIALS	85% Polyester, 15% Nylon			



Botanical



Retro Curve



Riso Wave

## Changing Poncho

**A towel and changing room in one: the newest travel and adventure essential.**

- **Portable Changing Room:** The poncho silhouette makes changing easy and private wherever you are.
- **Quick Drying:** Dries faster than comparable cotton fabric; easy to dry with convenient hang loop.
- **Sustainably Made:** 85% recycled fabric reduces environmental impact.
- **Odor Control:** Microban® antimicrobial odor control ensures freshness for multiple uses between wash cycles.
- **Kangaroo Pocket:** A large kangaroo-style pocket keeps hands warm or holds a change of clothes when you have nowhere else to set them when changing.
- **Made for Everyone:** Two sizes so everyone can have a comfortable fit.

SIZE	Small / Medium	Large / Extra Large
SKU	13867, 13869, 13871	13866, 13868, 13870
DIMENSIONS	84 x 130 x 0.25 cm (33 x 51 x 0.1 in)	97 x 142 x 0.25 cm (38 x 56 x 0.1 in)
WEIGHT	510 g (18 oz)	600 g (21 oz)
FITS	5'0" - 5'9" (152 cm - 175 cm)	5'9" - 6'4" (175 cm - 193 cm)
MATERIALS	85% Polyester, 15% Nylon	

# CASCADE DESIGNS

Dwyer Road, Midleton, Co.  
Cork P25H582, Ireland

Tel: +353 (0) 21 4621444

www.cascadedesigns.com  
© 2026 Cascade Designs, Inc.

## ARMENIA

ArpiUP  
Citadel Business Center,  
105/1 Teryan Street,  
Office 606, Yerevan, Armenia.  
Tel: (+374) 98 229042  
E-mail: operations@nrbgroup.  
company  
www.nrbgroup.company/arpiup

## AUSTRIA

Fa. Elementum – Outdoor  
Distribution  
Lindastrasse 119  
A-4820 Bad Ischl, Austria.  
Tel: (+43) 664-2066100  
E-Mail: office@elementum.at  
www.elementum.at

## BENELUX

C.J. Agencies BV  
Hermesweg 28, 3741 GP Baarn,  
Netherlands.  
Tel: (+31) 35 54 24 200  
Fax: (+31) 35 54 15 277  
E-mail: info@cjagencies.nl  
www.cjagencies.nl

## CROATIA & SLOVENIA

AlpVent d.o.o.,  
Dobračevska ulica 49,  
4226 Žiri, Slovenia.  
Tel (+386) 51 411 040  
E-mail: outdoor@alpvent.com

## CZECH & SLOVAK REPUBLIC

VERTONE s.r.o.  
Podhorská 240/168  
466 02 Jablonec nad Nisou  
Czech Republic  
Tel: +420 489 200 200  
E-mail: vertone@vertone.cz  
www.vertone.cz

## DENMARK

Fritidsagenten A/S  
Lejrvej 9, DK-3500 Værløse,  
Denmark.  
Tel: (+45) 4447 90 94  
Fax: (+45) 4447 80 84  
E-mail: info@fritidsagenten.dk  
www.fritidsagenten.dk

## ESTONIA

MATKaSPORT OÜ  
Tondi 17,11316 Tallinn, Estonia.  
Tel: (+372) 681 3130  
E-mail: info@matkasport.ee  
www.matkasport.ee

## FINLAND

Nordic Trail Oy  
Teletie 1  
96100 Rovaniemi  
Finland  
Tel: +358(0)207310431  
E-mail: myynti@nordictrail.fi  
www.nordictrail.fi

## FRANCE

P.L. Diffusion S.A.  
6 Rue Maurice Savin,  
26210 Moras En Valloire,  
France.  
Tel: (+33) 4 75 31 60 76  
Fax: (+33) 4 75 31 78 99  
E-mail: contact@pldiffusion.eu  
www.pl-diffusion.fr

## GERMANY

PURE OUT  
Dirk Grothstück  
Office and Showroom  
Emekesweg 5  
22391 Hamburg  
Tel: +49 178 - 6 34 44 47  
Fax: +49 40 - 35 67 59 66  
E-mail: dirk@pureout.de

## IRELAND

Showroom Neuss  
Euromoda / SFC  
Anton-Kux-Str. 2  
41460 Neuss  
Raum D 316  
www.pureout.de

Montana Trading - Thomas Seifert  
Hohndorfer Strasse 35,  
09376 Oelsnitz / E.  
Tel: 037298 - 30146  
Fax: 037298 - 30147  
E-mail: montanatradng@t-online.  
de

## ROCK'nd SNOW Outdoor Sports

Agency  
Charly & Andy Hetz  
Metzdorfer Str. 9, 95326 Kulmbach  
Tel: 09221/947385  
E-mail: info@rock-snow.com  
www.rock-snow.agency

## M-Services Florian Gschwendtner

Rungestr. 5, 86199 Augsburg.  
Showroom: MOC Munich, Room  
B202  
Tel: +49-(0)821-9066390  
Fax: +49-(0)821-906399  
Mobile: +49-(0)151-62806389  
E-mail: office@outdoor  
equipment.de  
www.outdoorequipment.de

## Sport Handelsagentur Weindel

Sascha Weindel  
Rheinfeldstrasse.21  
67354 Römerberg  
Tel: 06232/8156786  
Fax: 06232/8156787  
Mobile: 0171/2185366  
E-Mail: sascha@sport-  
handelsagentur.de  
www.Sport-Handelsagentur.de

## GEORGIA

MOGZAURI LLC  
193 Nutsubidze Str., Tbilisi,  
Georgia, 0186  
E-mail: info@mogzauri.ge  
Tel: +995 595 565 565

## GREECE

DIMITRIADIS S.A  
10 Moliereou st.  
Metamorfofi, GR 14452  
Greece  
Tel: +(30) 211 7056184  
Fax: +(30) 211 4111235  
E-mail: info@dimitriadis.gr  
www.dimitriadis.com.gr

## HUNGARY

Mountex Kft.  
2000 Szentendre, Rózsa u. 16.  
Hungary  
Tel.: (+36) 26 501 220  
E-mail: lisziczky.zsolt@mountex.hu  
www.mountex.hu

## ICELAND

Útilif  
Hagasmari 1  
201 Kópavogur  
Iceland  
Tel: (+354) 5228030  
Email sport@utilif.is  
www.utilif.is

## IRELAND

Progressive Distribution –  
Shane Cronin  
Unit 1 Glenside Industrial Estate  
Mill Lane, Palmerstown  
Dublin, D20 DY26  
Ireland  
Ph: +353 1 6208615  
E-mail: info@progressive  
distribution.ie  
www.progressivedistribution.ie

## ITALY

Outback 97 Srl  
Via Baioni, 24, 24123 Bergamo,  
Italy.  
Contact: Mauro Conti  
Tel: : +39 (0) 35 361103  
E-mail: cascadedesigns@outback.it  
www.outback.it

## KAZAKHSTAN

Outdoor Center Almaty  
Tole Bi Street 25,  
Almaty 050000,  
Kazakhstan  
Tel: +7 727 972 2199  
E-mail: info@camping.kz  
www.outdoorcenter.kz

## LATVIA

VESSPO Ltd.  
Brivibas Street 155,  
1012 Riga,  
Latvia.  
Tel: (+371) 67360330  
Fax: (+371) 67360330  
E-mail: vesspo@vesspo.lv  
http://www.celotajs.com

## LITHUANIA

LUKLA UAB  
Antakalnių g. 42  
LT-10304 , Vilnius  
Lithuania  
Tel: +370 610 32 831  
E-mail: sales@lukla.lt  
www.lukla.lt

## MACADONIA

Borche Janevski  
VEKON INT DOOEL  
Leninova br.60/2 lok3  
1000 Skopje, Macedonia  
Tel: +389 2 3298 259  
Fax: +389 2 3130 035  
E-mail: b.janevski@elteh.com.mk

## MALTA

Adventure Camping Shop Ltd  
Dun Karm Street, B'kara Bypass  
c/w Giovanni Papaffy Street  
BKR 4021 Birkirkara  
MALTA Tel: (+356) 2144 3386  
E-mail: info@adventureshop.mt

## MOLDOVA

X-Style Outdoor Equipment  
Center  
bd.Grigore Vieru 27  
Moldova  
Tel: (+373) 22210050  
E-mail: info@xstyle.md  
www.xstyle.md

## NEPAL

Mountain Outdoors Pvt. Ltd. -  
Tendi Sherpa  
Post Box 1542, Tridevi Marg.,  
Thamel, Kathmandu, Nepal.  
Tel: (+977) - 14411800  
Fax: (+977) - 14436776  
E-mail: mountainoutdoors12@  
gmail.com

## NORWAY

Varri AS,  
Hasleveien 15E,  
0571 Oslo, Norway.  
Tel: +47 22 71 92 00  
Fax: +47 22 71 92 01  
E-mail: post@varri.no  
www.varri.no

## POLAND

Paker sp. z o.o. - Pawel Trochimiuk  
ul. Plocka 17 lok. 8, 01-231  
Warszawa,  
Poland.  
Tel: (+48) 22 631 82 01  
Fax: (+48) 22 631 20 64  
E-mail: paker@paker.com.pl  
www.paker.com.pl

## PORTUGAL

Outprospirit, Lda  
Zona Comercial de Alfragide  
Av. dos Cavaleiros, n.º72, Piso 1,  
2790-045 Carnaxide  
Portugal  
Tel: +351 218 435580  
E-mail: comercial@outpro.pt  
www.outpro.pt

## ROMANIA & BULGARIA

MM SPORT  
Strada Vasile Lucaciu, Nr. 82 – 84,  
Bucuresti,  
Sector 3, 030696, Romania.  
Tel: (+40) 787 786867, (+40) 722  
400936  
Email: cascade.designs@mmsport.  
ro  
www.mmsport.ro

## SOUTH AFRICA

Eiger Equipment (Pty) Ltd.  
Unit 3, De Waal Park  
Greenville Road, Diep River 7800  
Cape Town, South Africa  
Contact: John Fontyn  
Tel.+27.021.555.0363  
Fax.+27.021.551.3544  
E-mail: info@eigerequipment.  
co.za  
www.eigerequipment.com

## SPAIN

Pro Wind SL – Richard Elvira  
Apdo. de Correos 59  
33420 LUGONES  
Spain  
Tel: (+34) 916304996  
E-mail: info@prowind.es

## SWEDEN

Granitbiten - Thomas Breeding  
Atlasgatan 3  
S-113 20 Stockholm, Sweden.  
Tel: (+46) 8 611 39 49  
Fax: (+46) 8 611 39 12  
E-mail: info@granitbiten.com  
www.granitbiten.com

## SWITZERLAND

ICON Outdoor AG  
Aathalstrasse 76a, CH-8610 Uster,  
Switzerland.  
Tel: (+41) 44 388 41 21  
Fax: (+41) 44 382 20 76  
E-mail: contact@icon-outdoor.ch  
www.icon-outdoor.ch

## TURKEY

Nunatak Distribution Ltd.  
Aşagi Oveçler Mah. 1324. Cad.  
No:39/2  
Cankaya/Ankara, Turkey.  
Tel : +90 312 440 18 21  
Fax: +90 312 472 03 44  
E-mail: f.sahin@nunatak.com.tr  
www.nunatak.com.tr

## UAЕ

Global Climbing Trading LLC  
PO Box 474476  
Dubai Investment Park 1  
District 598, Street No 77  
Dubai, United Arab Emirates  
Tel: +971 4 8829 361  
Fax: +971 4 8829 362  
E-mail: info@globalclimbing.com  
www.globalclimbing.com

## UKRAINE

Arnica Distribution Ltd. –  
Maria Khramova  
A.Tsedika str 12  
Kyiv 03057,  
Ukraine.  
Tel: (+380) 99 2776722  
E-mail: info@arnica.com.ua

## UNITED KINGDOM

Proagencies Ltd.  
Lawrence Friell +44 7795 904043  
Matt Moore +44 773 4215821  
E-mail: enquiries@proagencies.com  
www.proagencies.com

## REPAIRS DEPARTMENT

CASCADE DESIGNS LTD.  
Dwyer Road, Midleton, Co. Cork,  
Ireland.  
Tel: +353 (0) 021 4621444  
E-mail: warranty@  
cascadedesigns.ie