



TRAVAINI PUMPS[®] USA

Liquid Ring, Rotary Vane Vacuum Pumps & Compressors.

 **pompetravaini**

COMMITTED TO STAY **AHEAD** >>>



COMPRESSOR SYSTEMS

Standard water sealed and oil sealed compressor systems. Maximum flow up to 700 CFM, max discharge pressure 30 PSIG (2.1 barg) at 60Hz.

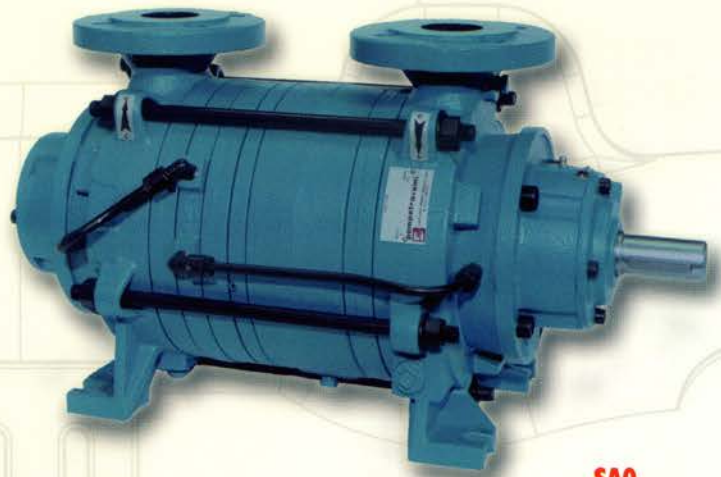

SAO

Double acting liquid ring compressor. Capacity up to 110 CFM, max pressure 150 PSIG at 60Hz.

VACUUM PUMPS



PVL ROTARY VANE VACUUM PUMPS

Single stage, oil lubricated rotary vane vacuum pumps, air cooled, with automatic oil recirculation by means of differential pressure. Capacity up to 700 ACFM, max vacuum 29.9" HgV (0.5 Torr) at 60Hz..



Single stage liquid ring
Capacity to 295 ACFM, max vacuum 28.95 "HgV



TRVK - TRSK

Single stage liquid ring vacuum pumps.
Capacity to 21200 ACFM,
max vacuum 28.74/24"HgV
(30/150 Torr) at 60Hz.



TRM

Close-coupled single stage
liquid ring vacuum pumps.
Capacity to 160 ACFM,
max vacuum 28.95 "HgV
(25Torr) at 60Hz.



TRAVAINI PUMPS® USA

TRV

Double stage liquid ring vacuum pumps.
(25 Torr) at 60Hz.



TRH - TRS

Double or single stage liquid ring vacuum pumps.
Capacity to 2150 ACFM, max vacuum 28.95/24"HgV (25/150 Torr) at 60Hz.





DYNASEAL

Standard air cooled closed-loop oil sealed vacuum systems.
Capacity up to 2150 ACFM, max vacuum to 29.3 "HgV (15 Torr) at 60Hz.

SPECIAL SYSTEMS

Custom designed water sealed and oil sealed systems to meet your application needs, for all types of industry including chemical, environmental, medical, food and beverage. Please consult Travaini Pumps USA Engineering.

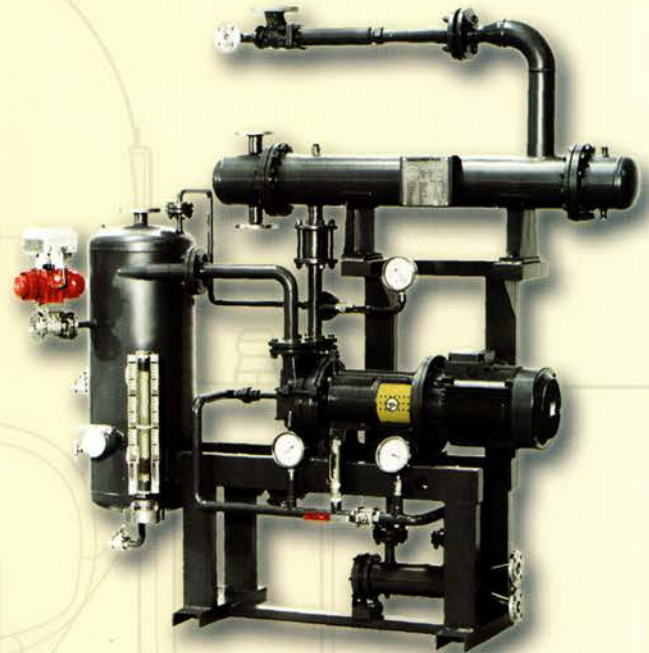

WATERSEAL

Standard water cooled and water sealed vacuum systems, in once through, partial recovery and full recovery designs.
Capacity up to 2150 ACFM, max vacuum to 28.95/24 "HgV (25/150 Torr) at 60Hz.



PVL ROTARY VANE VACUUM SYSTEMS

Standard factory engineered vacuum systems, either tank mounted, stack mounted or based mounted in multiple pump configurations including systems built to NFPA 99 specifications, for medical vacuum including for use in laboratory and hospitals. Please consult Travaini Pumps USA Engineering for additional performance capabilities. Capacity up to 2800 ACFM, max vacuum to 29.9 "HgV (0.5 Torr) at 60Hz.

HYDROTWIN / OILTWIN

PLC controlled rotary lobe blower with LRVP package for very high vacuum needs, with total water or oil recirculation.
Capacity up to 2300 ACFM, max vacuum to 29.86 "HgV (1.5 Torr) at 60Hz.

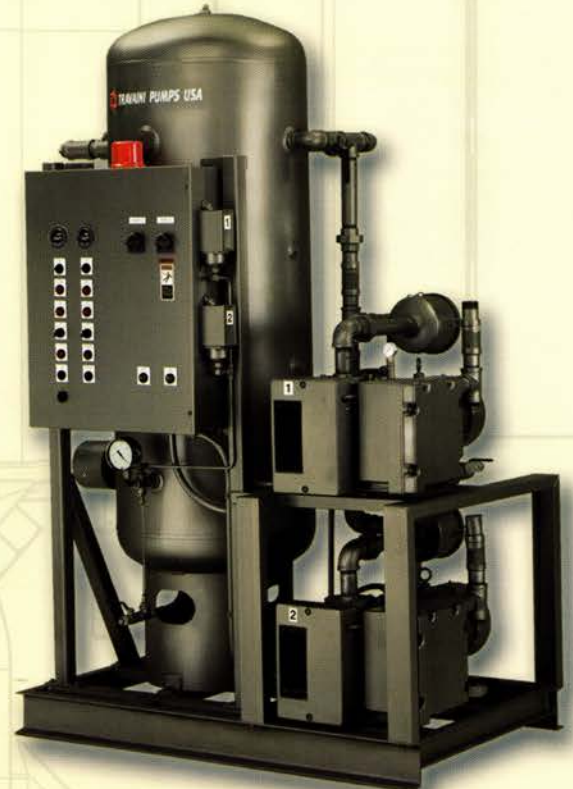

TRMN & TRVN

Single stage liquid ring vacuum pumps.
Capacity to 700 m³/h (410 ACFM), max vacuum
33 mbar (28.95 "HgV / 25 Torr) at 50/60 Hz.



HYDROCOMBI

Vacuum packages for full recovery
of vapors and gases at high vacuum.
Capacity to 8000 m³/h (4700 ACFM), max vacuum 1 mbar
(29.88 "HgV / 0.75 Torr) at 50/60 Hz.



SPECIAL PRODUCTS

LIQUID RING VACUUM PUMPS & SKID

pompetravaini s.p.a.

HYDROREC

Vacuum packages for full recovery of vapors and gases.
Capacity to 1400 m³/h (820 ACFM), max vacuum 6 mbar
(29.74 "HgV / 4.7 Torr) at 50/60 Hz.



TBH - TBK

Self-priming centrifugal pumps.
Capacity up to 369 GPM, head to 1171 feet at 60Hz.
Also available with magnetic drive.



TMA

Multistage centrifugal pumps.
Capacity up to 237 GPM,
head to 1338 feet at 60Hz.

TCH & MCU-CH - TCK

Monostage centrifugal pumps with closed impeller
according to ISO 2858 & 5199 (series TCH).
Capacity up to 9690 GPM, head to 535 feet at 60Hz.
Also available with magnetic drive.

CENTRIFUGAL PUMPS



TCD

Monostage centrifugal pumps with closed impeller
for thermal oil up to 610°F.
Capacity up to 1850 GPM, head to 470 feet at 60Hz.



TBA - TBAK

Self-priming centrifugal pumps with low NPSH.
Capacity up to 185 GPM, head to 1171 feet at 60Hz.
Also available with magnetic drive.





BLOWERS

Positive displacement blower.
Capacity to 2600 m³/h
(1535 ACFM),
max pressure 1800 mbar
(23.6"Hg/11.6 PSIG) at 50/60 Hz.

EXHAUSTERS

Positive displacement exhauster.
Capacity to 2600 m³/h
(1535 ACFM),
max vacuum 500 mbar
(14.7"HgV/375 Torr) at 50/60 Hz.



DVD2

Active and dynamic manager
of vacuum process production/control.

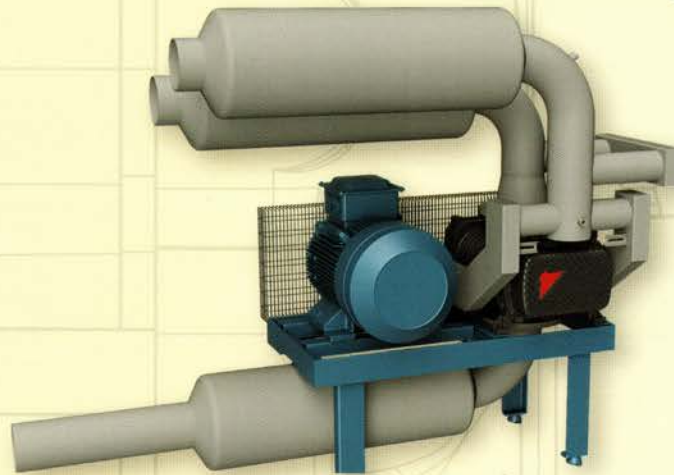

BORA PRODUCTS

BLOWERS - EXHAUSTERS - BOOSTER HV - DVD2 - SPECIALS



BOOSTER HV

High vacuum booster.
Capacity to 3250 m³/h (1910 ACFM),
max vacuum 0.01 mbar (29.91"HgV/0.0075 Torr) at 50 Hz.
Capacity to 3900 m³/h (2290 ACFM),
max vacuum 0.01 mbar (29.91"HgV/0.0075 Torr) at 60 Hz.

SPECIALS

Customized versions on request.



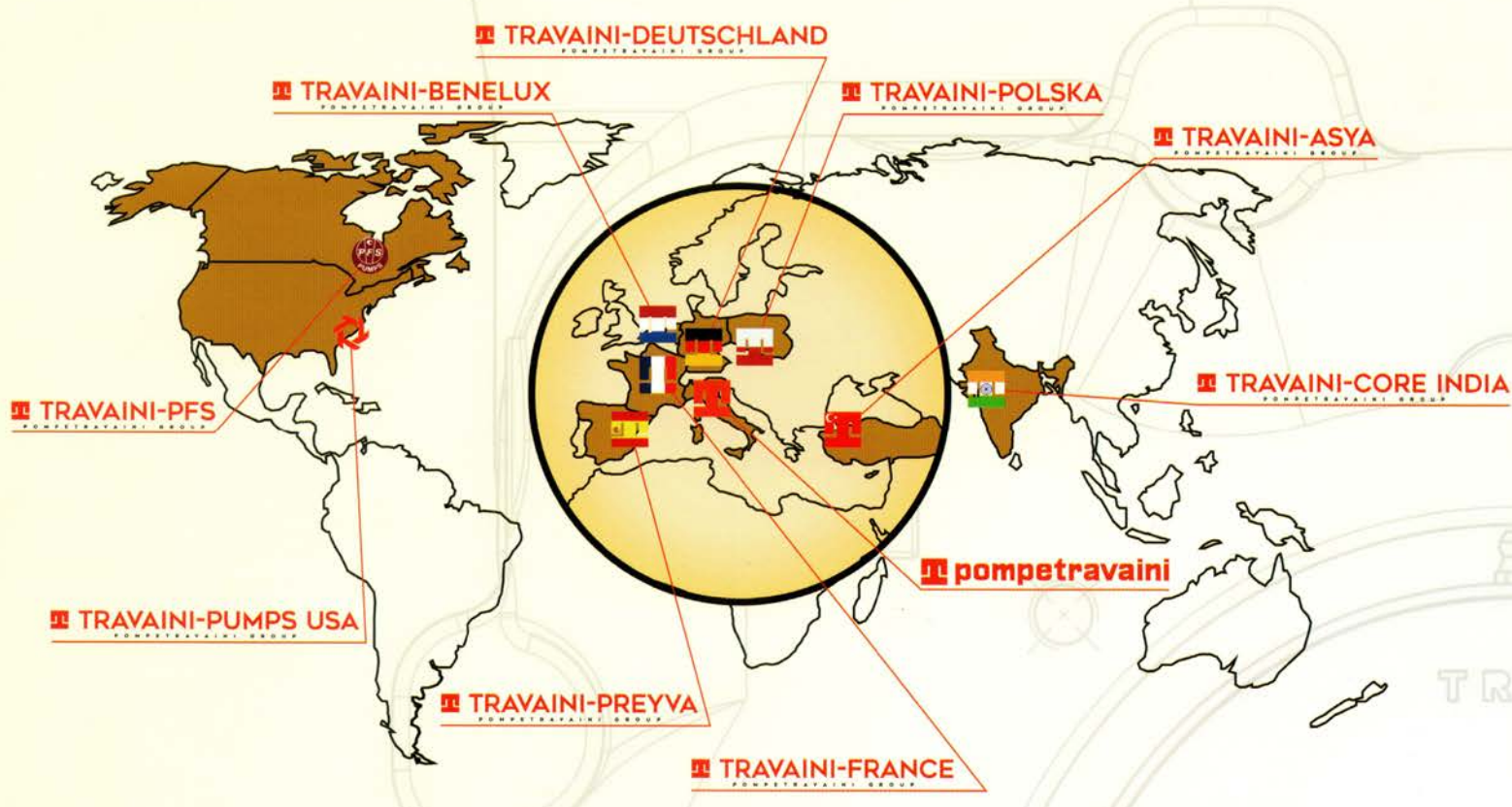

200 Newsome Drive - Yorktown, VA 23692
 Phone: (757) 988-3930
www.travaini.com customerservice@travaini.com

