

CARPORT METTA

MONTAGEANLEITUNG

3000 X 5300



Wir schätzen Ihren Kauf unseres Carport.

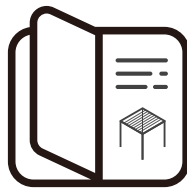

Montageanleitung

Diese Anleitung bietet Ihnen eine Schritt-für-Schritt-Anweisung zur Montage und Pflege Ihrer Carport, damit Sie jahrelange Freude und zuverlässige Nutzung genießen können.

Achten Sie darauf, alle Schritte sorgfältig zu befolgen, da eine falsche Installation zu schweren Verletzungen führen kann.

WICHTIG:

Zur Sicherheit aller Personen ist es entscheidend, diese Anweisungen zu befolgen. Bitte bewahren Sie diese Anleitung zur späteren Referenz auf.

Kinder sowie Personen mit eingeschränkter Erfahrung oder Behinderungen dürfen das Produkt nur benutzen, wenn sie ordnungsgemäß beaufsichtigt oder geschult wurden und die potenziellen Risiken kennen.

Kinder dürfen das Produkt nicht als Spielzeug verwenden. Während Reinigungs- oder Wartungsarbeiten müssen sie unter Aufsicht eines Erwachsenen bleiben.

Dieser Carport ist für den privaten Außenbereich konzipiert und bietet Schutz vor direkter Sonneneinstrahlung, Blendung und Hitze.

Jegliche Nutzung oder Änderungen, die nicht in dieser Anleitung beschrieben sind, gelten als unsachgemäß und können erhebliche Risiken für Benutzer und Eigentum darstellen. Solche Handlungen führen zum Erlöschen der Produktgarantie.

VOR DER INSTALLATION

BEREITEN SIE ALLE BENÖTIGTEN WERKZEUGE VOR

Um Ihren Carport ordnungsgemäß und sicher zu montieren, stellen Sie sicher, dass Sie die folgenden Werkzeuge und Zubehörteile zur Hand haben, da diese nicht im Lieferumfang enthalten sind.



2xLeiter



Arbeitshandschuhe



Sechskant-Schlüssel-/Werkzeugsatz



Schraubendreher



Hammer



Maßband



Sicherheits-helm



Cuttermesser



Bohrmaschine



Wasserwaage



Akkuschrauber



Schere

ÜBERPRÜFEN SIE AUF FEHLENDE TEILE:

Bevor Sie mit der Installation beginnen, überprüfen Sie, ob alle notwendigen Teile für die Montage Ihres Carports vorhanden sind. Kontrollieren Sie sorgfältig, ob die Anzahl der Teile mit dem von Ihnen gekauften Modell übereinstimmt.

Sollten Teile fehlen, wenden Sie sich bitte an den Kundendienst, bevor Sie mit der Installation fortfahren.

BEREITEN SIE DIE TEILE FÜR JEDEN SCHRITT VOR:

Im Installationsabschnitt der Anleitung werden in jedem Schritt die benötigten Teile und deren Maßen angegeben. Wir empfehlen, die erforderlichen Teile im Voraus für jeden Schritt bereitzulegen. Dies spart Zeit und erleichtert den Montageprozess. Um Beschädigungen der lackierten Oberflächen zu vermeiden, legen Sie die Teile nach Möglichkeit auf Karton oder eine andere weiche Unterlage.

WÄHLEN SIE EINEN GEEIGNETEN STANDORT:

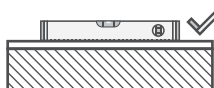
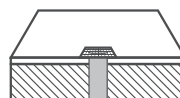
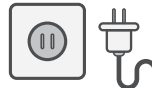
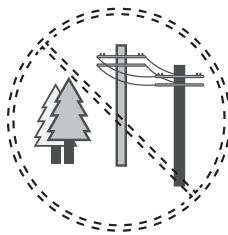
				
Der Boden sollte fest und eben sein.	Der Boden muss flach und gleichmäßig sein.	Stellen Sie sicher, dass eine ausreichende Wasserableitung in der Umgebung vorhanden ist.	Stellen Sie sicher, dass der Standort bei Bedarf einen einfachen Zugang zu Strom hat.	Vermeiden Sie Bereiche mit überhängenden Bäumen oder Stromleitungen.

WARNUNG:

Viele Flächen im Außenbereich haben ein leichtes Gefälle, um Regenwasser von Gebäuden oder anderen Strukturen abzuleiten. Für die ordnungsgemäße Installation des Carports ist jedoch eine absolut ebene Fläche erforderlich. Kleine Kieselsteine oder unebener Boden können verhindern, dass der Carport sicher verankert wird.

Wird der Carport auf einer unebenen Fläche installiert, kann dies die Funktion der Zubehörkomponenten beeinträchtigen und zum Erlöschen der Produktgarantie führen. Gegebenenfalls müssen die Höhen des Untergrunds angepasst werden, um eine korrekte Montage zu gewährleisten.

BEREITEN SIE DAS FUNDAMENT VOR:

Stellen Sie sicher, dass Sie folgende Punkte beachten:

Überprüfen Sie unterirdische Rohre und Kabel (kontaktieren Sie die zuständigen lokalen Behörden, bevor Sie graben). Klären Sie mit den örtlichen Behörden, ob eine Baugenehmigung erforderlich ist. Wenn Sie sich für ein Betonfundament entscheiden, konsultieren Sie einen renommierten Fachbetrieb.

Pergola Größe

Planungsgröße

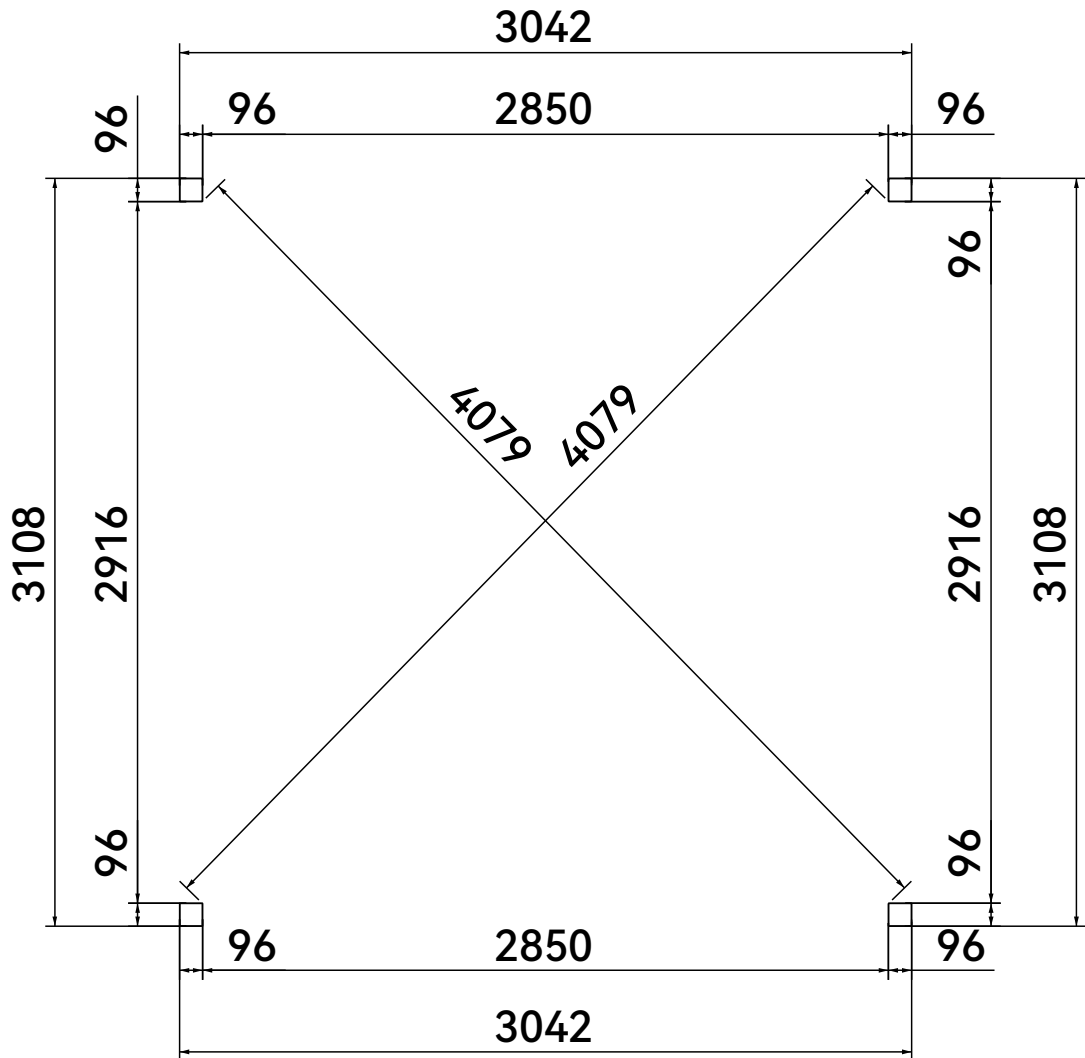





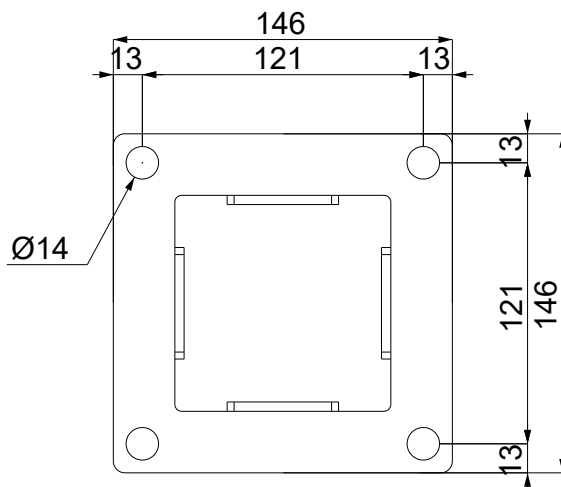
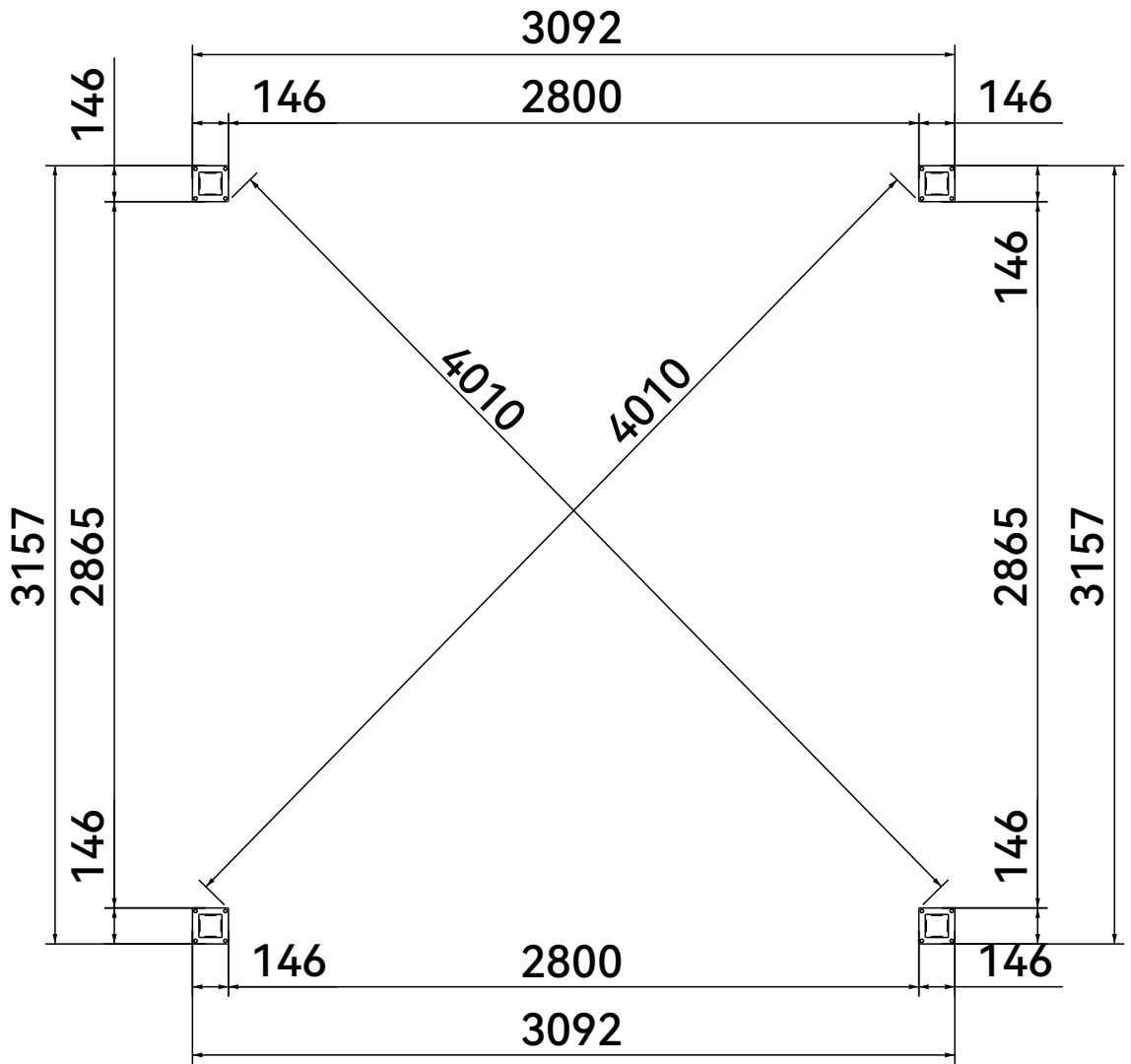



Pergola Größe

Bodenplatten-Lageplan







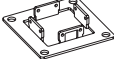

Lieferumfang

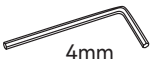
KARTON 1/8

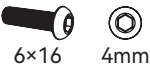

Nr.	Profil	Bild	Maße	Mg.
A1			96X96 L=2371mm	1
A2			96X96 L=2371mm	1
A3			96X96 L=2294mm	1
A4			96X96 L=2294mm	1

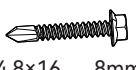
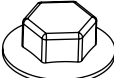

Nr.	Bild	Mg.
Q1-1		4
Q2-1		4

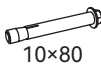
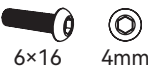
Nr.	Bild	Mg.
Z3	 4mm	1
Z4	 4mm	1

Nr.	Bild	Mg.
Q20-2	 6x16 4mm	161
Q31	 5x19 8mm	4
Q32	 4.8x45 8mm	40
Q32-1	 4.8x16 8mm	30
Q33		70
Q34		10





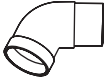



Nr.	Bild	Mg.
Q15	 10x80	16
Q20-2	 6x16 4mm	32

Nr.	Bild	Mg.
Z9	 8mm	1
Z10		1



Nr.	Bild	Mg.
Q35		2
Q36		1
Q37		3

Lieferumfang







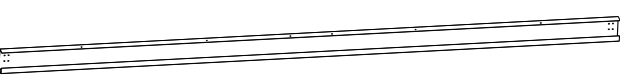

KARTON 2/8

Nr.	Profil	Bild	Maße	Mg.
C1			55X163 L=2350mm	1
C2			55X163 L=2350mm	1
C3			55X163 L=2950mm	1
C4			55X163 L=2950mm	1

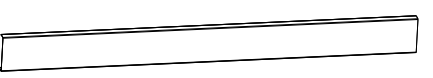

KARTON 3/8

Nr.	Profil	Bild	Maße	Mg.
D3			50X173 L=3110mm	1
D4			50X150 L=3110mm	1

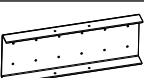
KARTON 4/8





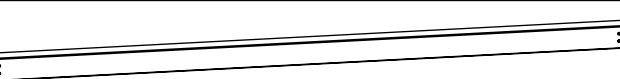

Nr.	Profil	Bild	Maße	Mg.
B2			50X178 L=2952mm	1
B3			50X178 L=2952mm	1
B4			50X178 L=2430mm	1
B5			50X178 L=2430mm	1
C-1			400X140 L=400mm	2







KARTON 5/8

Nr.	Profil	Bild	Maße	Mg.
D1			50X120 L=3110mm	2
D2			50X120 L=3110mm	2

Lieferumfang

KARTON 6/8

Nr.	Profil	Bild	Maße	Mg.
D2			50X120 L=3110mm	1
F1			109X70 L=3210mm	1
B1			50X180 L=3214mm	1

Nr.	Profil	Bild	Maße	Mg.
E1			50X50 L=90mm	1
E2			50X50 L=790mm	1
E3			50X50 L=1680mm	1

Nr.	Bild	Mg.
T1		1

Nr.	Bild	Mg.
T2		1

KARTON 7/8

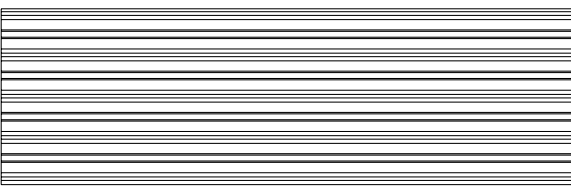
Nr.	Profil	Bild	Maße	Mg.
W1			25X890 L=2750mm	4

CARTON 8/8

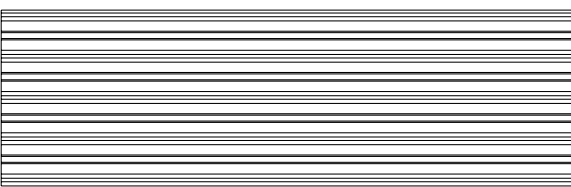
Nr.	Profil	Bild	Maße	Mg.
W1			25X890 L=2750mm	4

Lieferumfang

Bevor Sie mit der Montage Ihres Carports beginnen, müssen Sie überprüfen, ob alle aufgeführten Teile vorhanden und unbeschädigt sind.

Fehlende Teile müssen innerhalb von 10 Tagen nach Lieferung gemeldet werden.

Entsorgen Sie die Verpackung nicht, bevor Sie sichergestellt haben, dass das Produkt einwandfrei funktioniert.

A1		1
A2		1
A3		1
A4		1

Q1-1		4
Q2-1		4

Q20-2		32
-------	--	----

Z3	
Z4	

Achtung:
Bitte ziehen Sie die Schrauben nach dem Einsetzen zunächst von Hand fest.

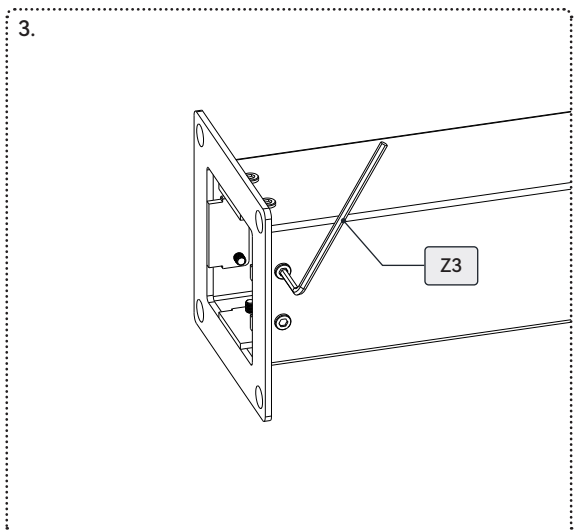
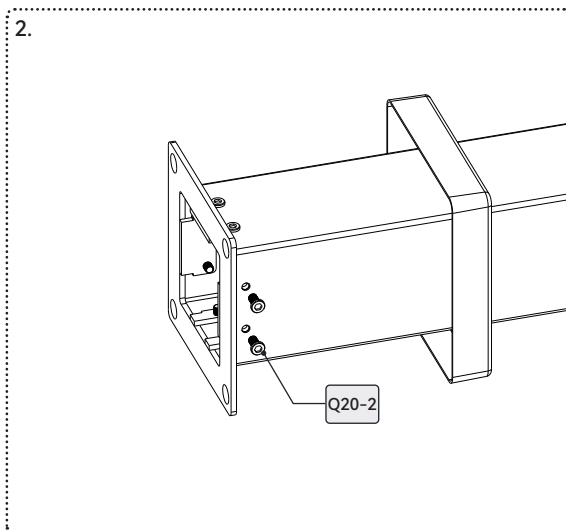
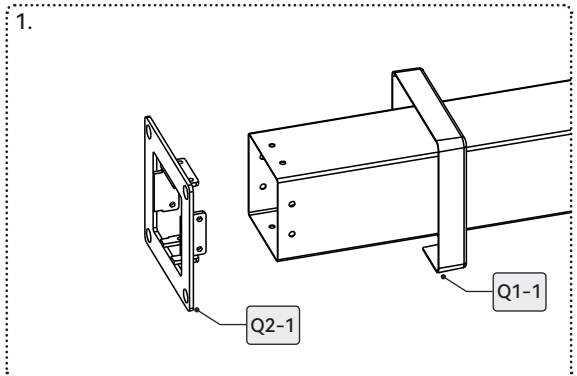
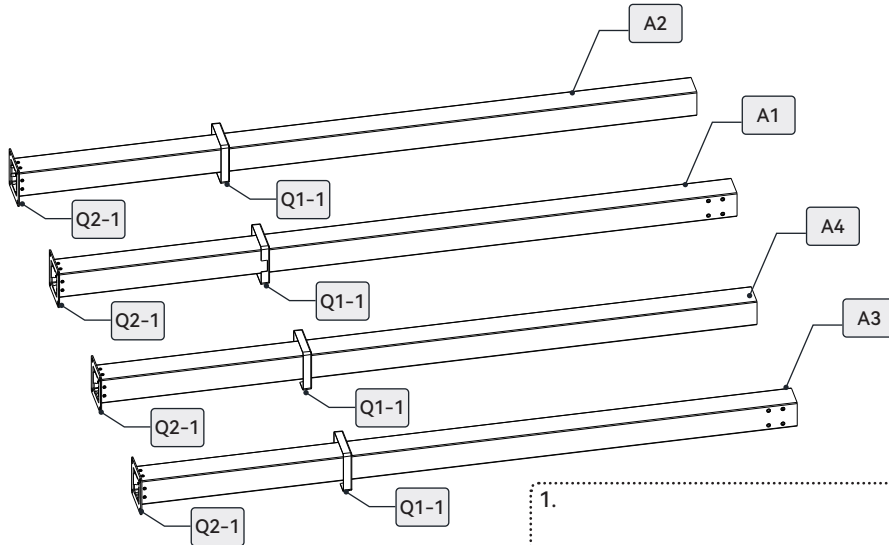

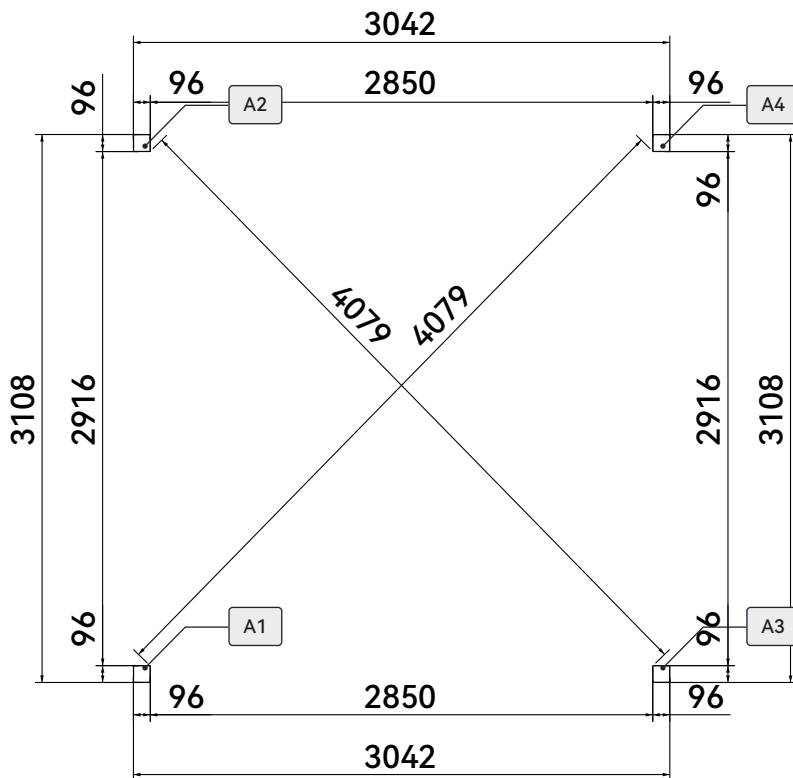
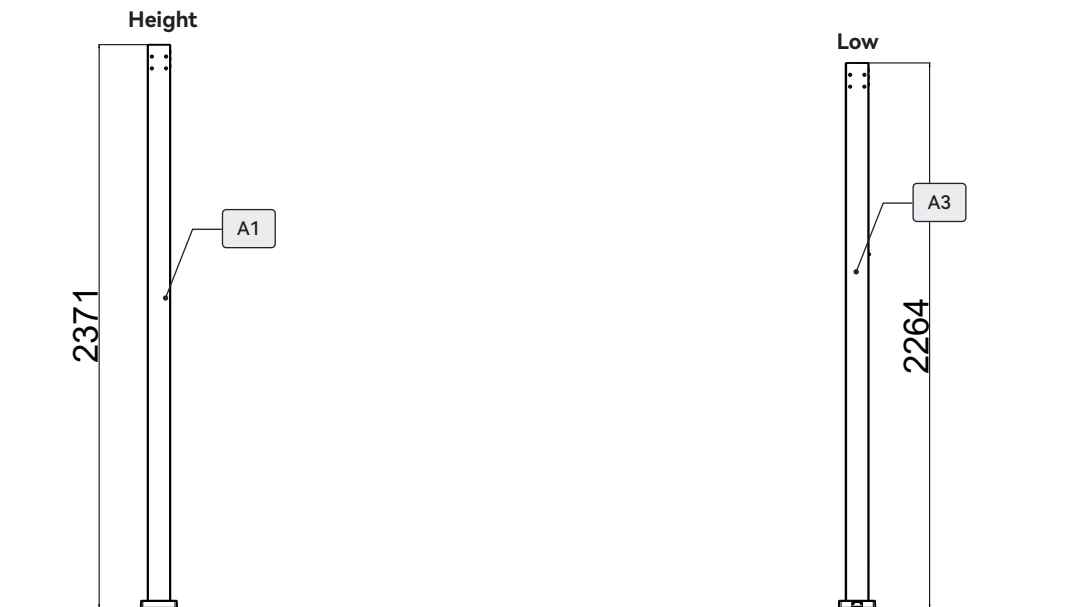

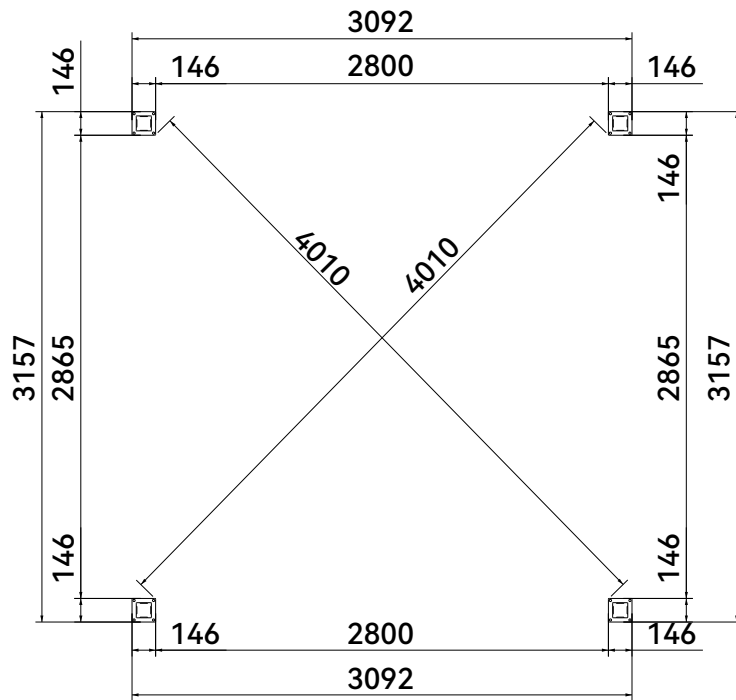

1.

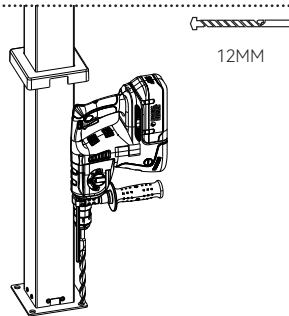

1. Bohren Sie die Löcher mit einem 12-mm-Schlagbohrer.

2.

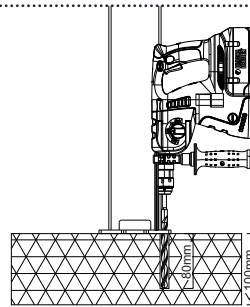

2. Um 100 mm nach unten verlängern.

3.

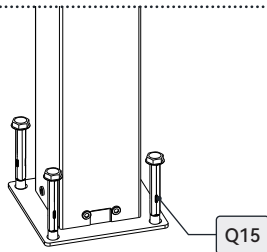



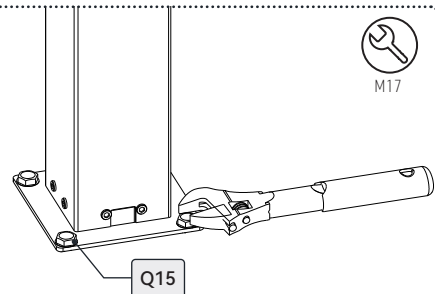

3. Schlagen Sie die Spreizdübel mit einem Hammer ein.



4.



4. Setzen Sie die Spreizbolzen ein und ziehen Sie diese mit einem M17-Schlüssel fest.

C1		1
C2		1
C3		1
C4		1
C-1		2

Q20-2		6x16		4mm	24
-------	---	------	--	-----	----

Z3		4mm
Z4		4mm

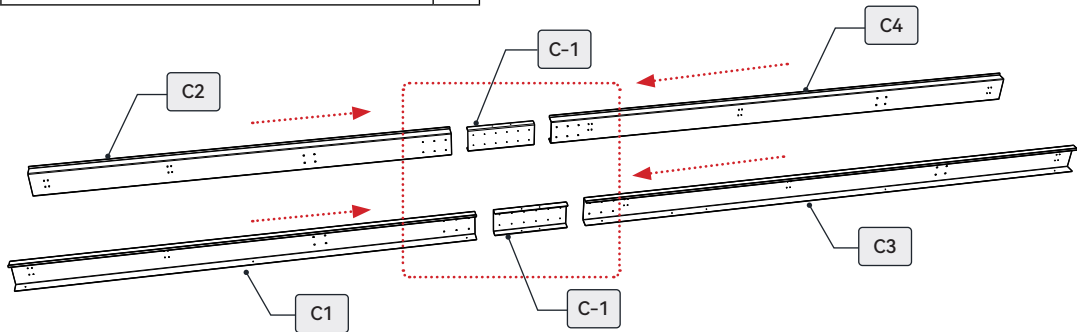

1.

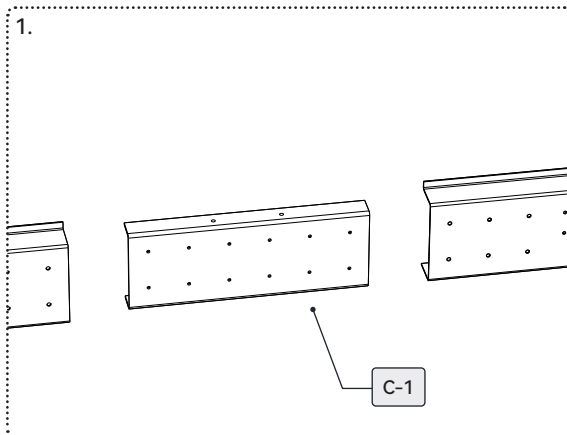

1. Verwenden Sie C-1-Verbinders, um die Träger C2 und C4 sowie die Träger C1 und C3 zu verbinden. Beachten Sie, dass die Bodenplatte von C-1 auf der Oberseite der Träger positioniert werden muss.

2.

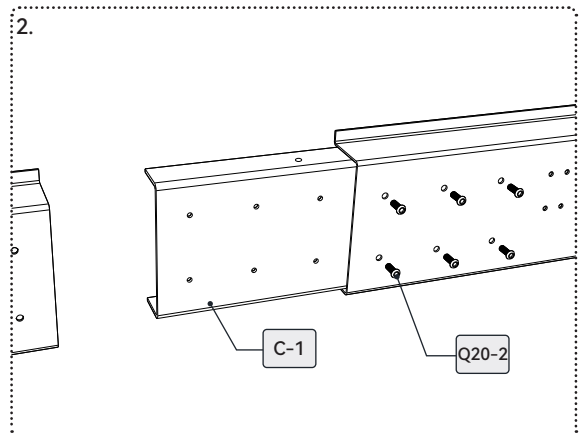

2. Eindrehen der Befestigungsschrauben Q20-2, um das Zubehör am Träger zu befestigen.

3.

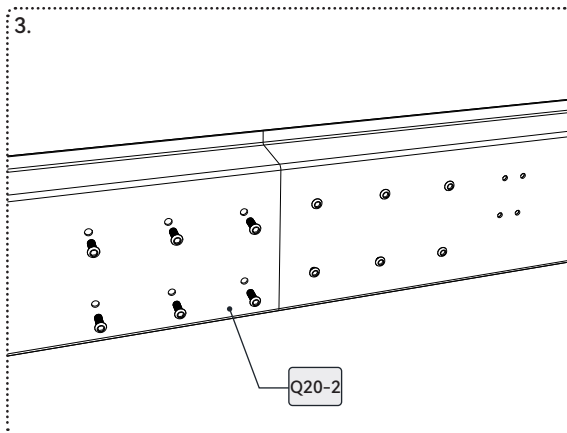

3. Befestigen Sie den Träger auf der anderen Seite ebenfalls mit Q20-2-Schrauben.

4.

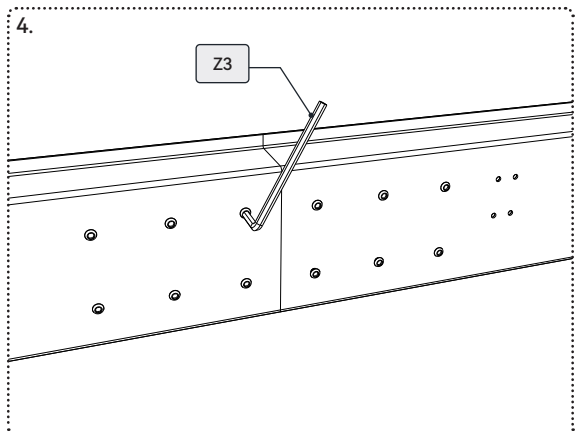



4. Ziehen Sie die Schrauben mit Werkzeug Z3 fest.

6.

Installation Process

D1		2
----	---	---

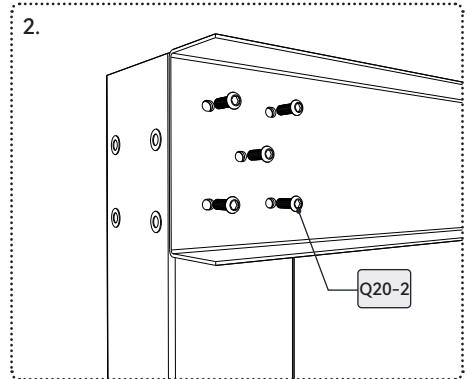
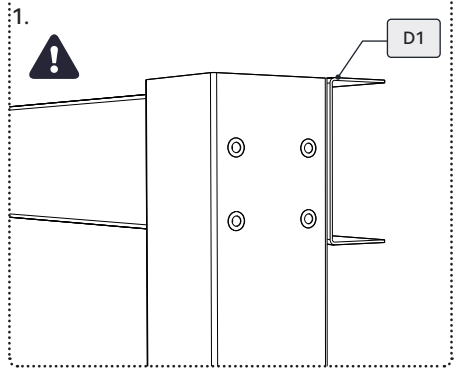
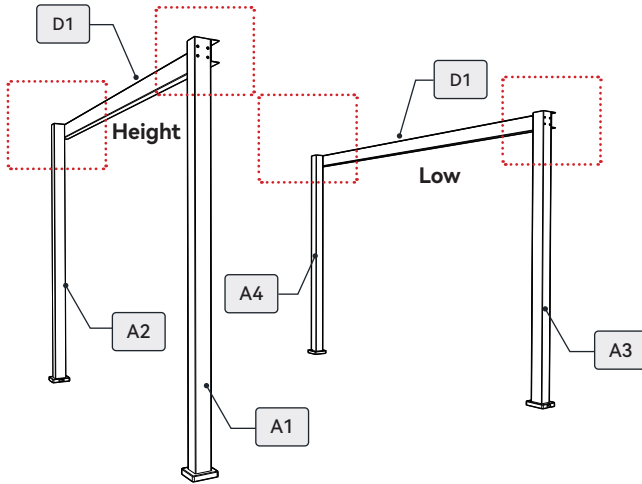

Befestigen Sie den Träger D1 direkt an der Seite der Säule mit den fünf vorgebohrten Löchern.

Q20-2		20
Z3		4mm
Z4		4mm





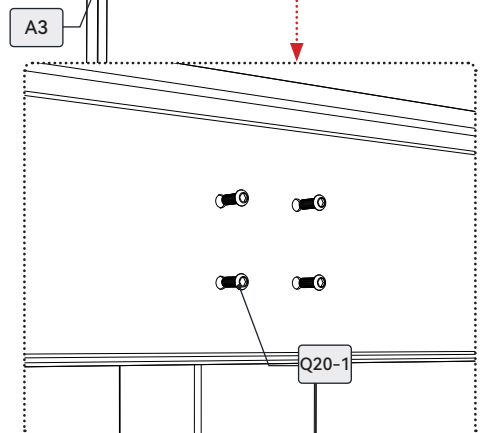
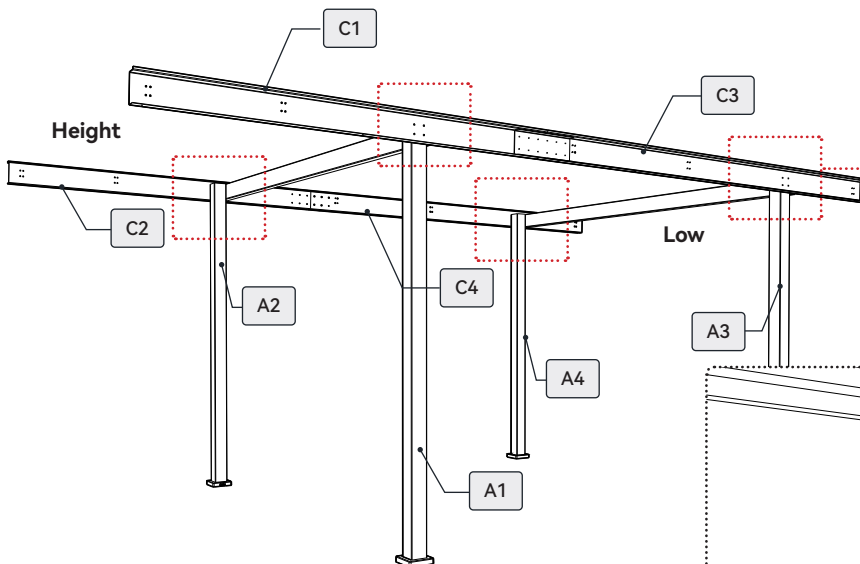

6.

Befestigen Sie den Träger D1 direkt an der Seite der Säule mit den fünf vorgebohrten Löchern.

Q20-2		16
Z3		4mm
Z4		4mm



D2		3
----	---	---



Q20-2			24	Z3		4mm
Q34			6	Z4		4mm

Achtung:

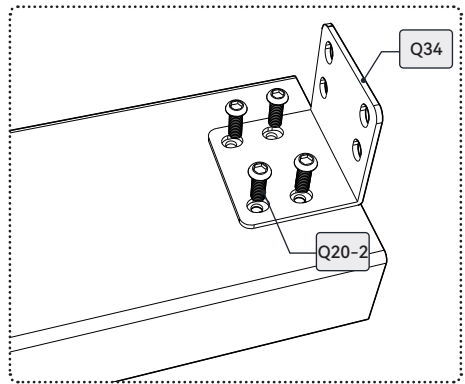
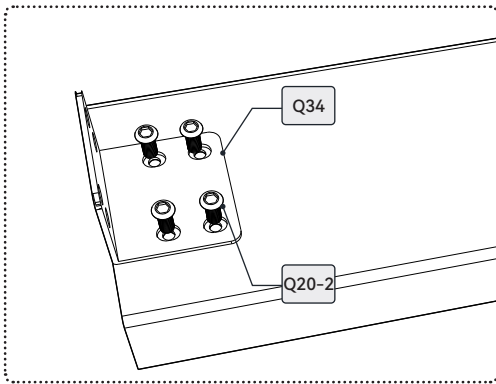
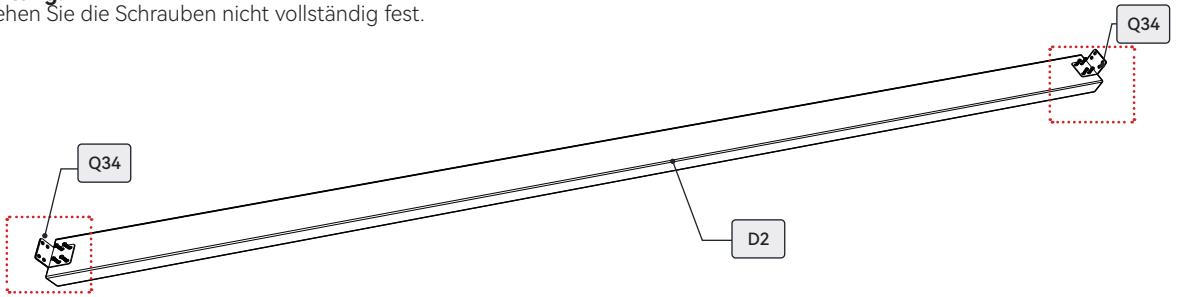
Ziehen Sie die Schrauben nicht vollständig fest.



Montieren Sie den D2-Nebenträger mit dem vormontierten Q34-Trägerzubehör auf den Hauptträger.

Q20-2			24	Z3		4mm
				Z4		4mm

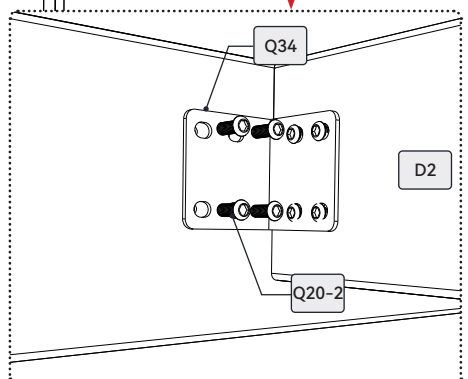
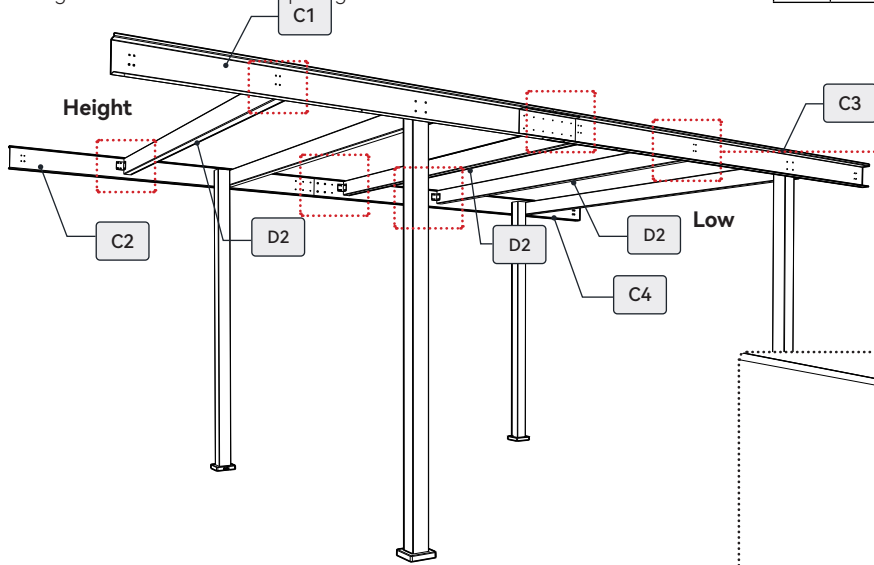

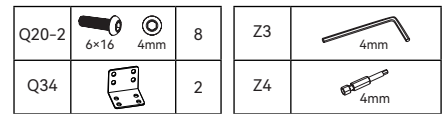
**Achtung:**

Ziehen Sie die Schrauben nicht vollständig fest.

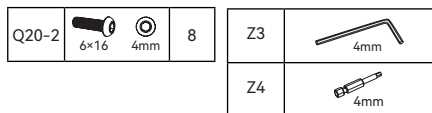
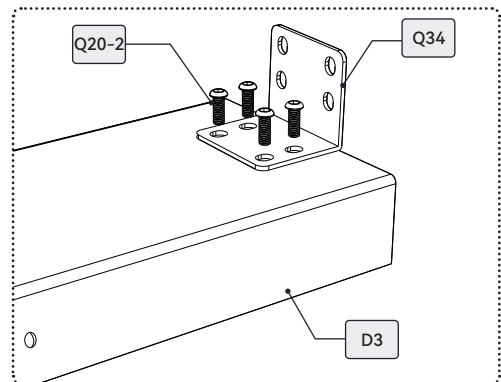
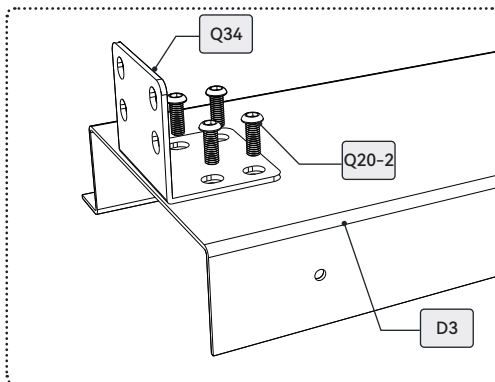
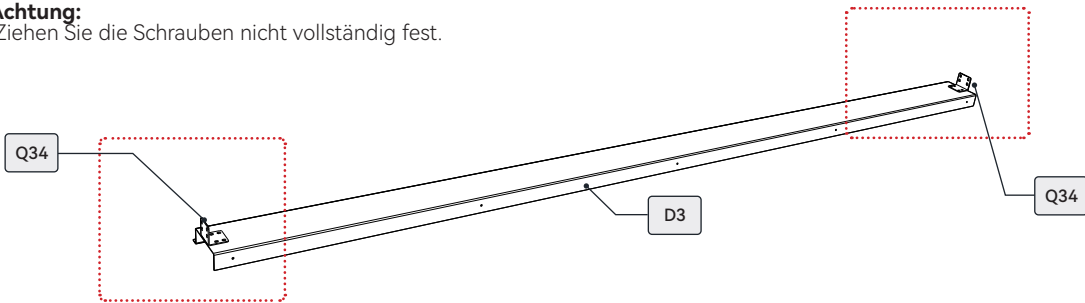

Montieren Sie den D3-Nebenträger mit dem vormontierten Q34-Trägerzubehör auf den Hauptträger.

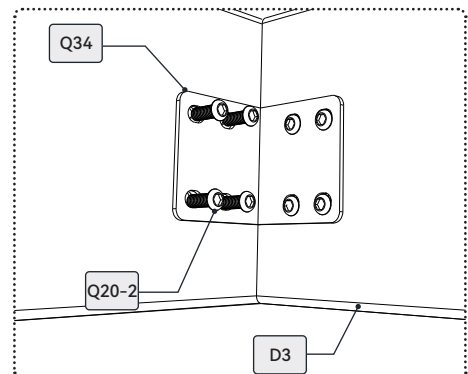
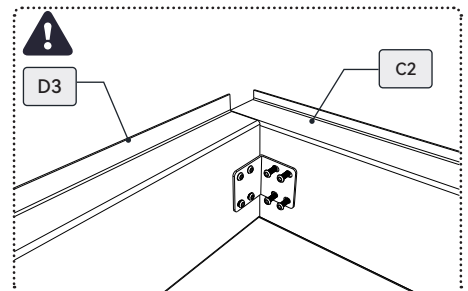
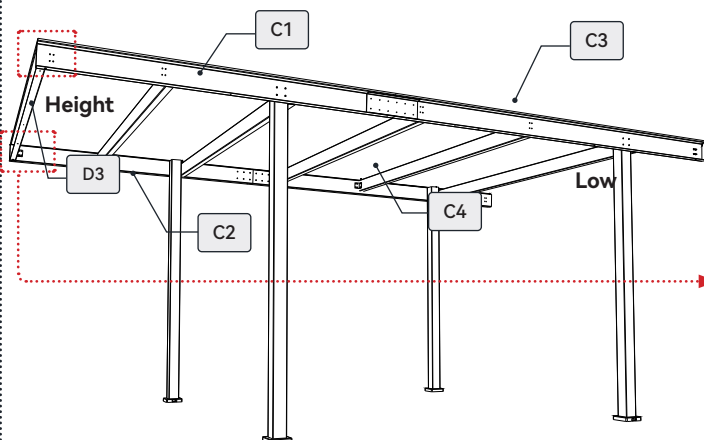

Installation Process

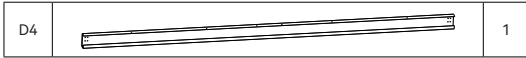

Q20-2		6x16		4mm	8	Z3		4mm
Q34					2	Z4		4mm

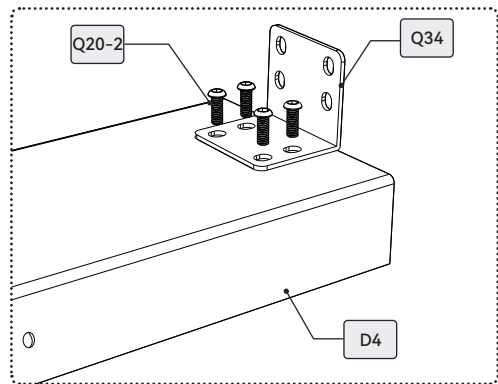
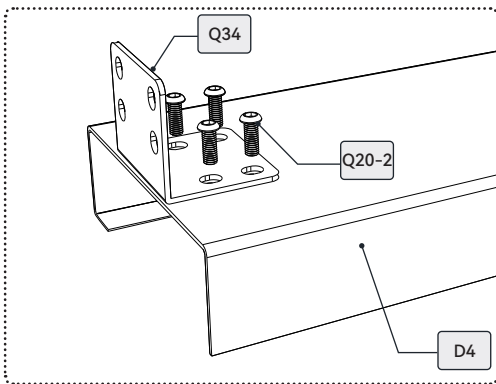
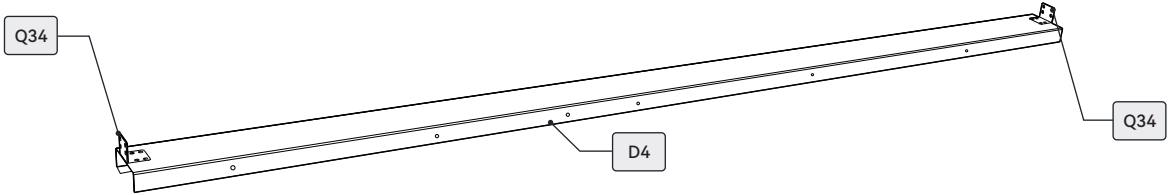

Q20-2		6x16		4mm	8	Z3		4mm
						Z4		4mm

Montieren Sie den D4-Nebenträger mit dem vormontierten Q34-Trägerzubehör auf den Hauptträger.

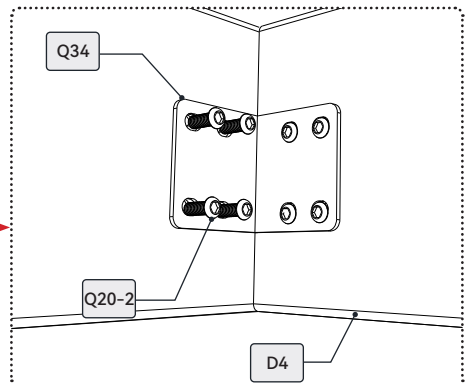
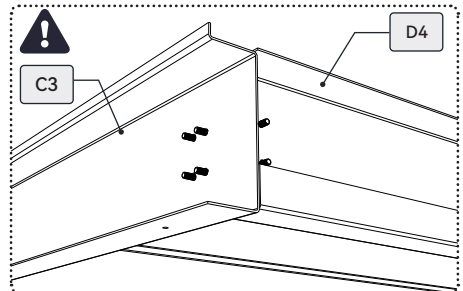
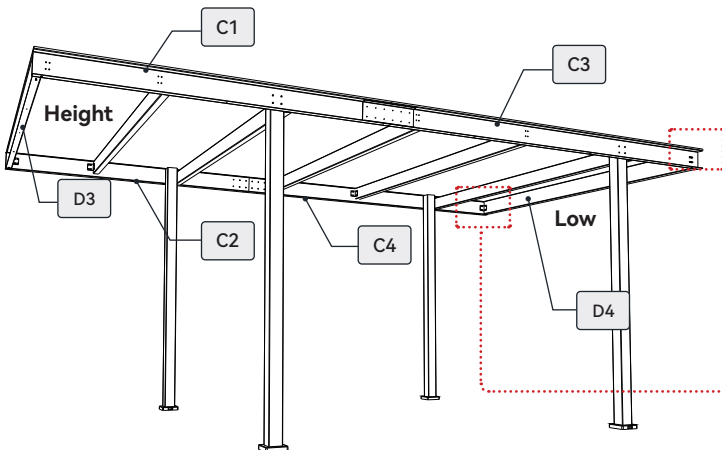

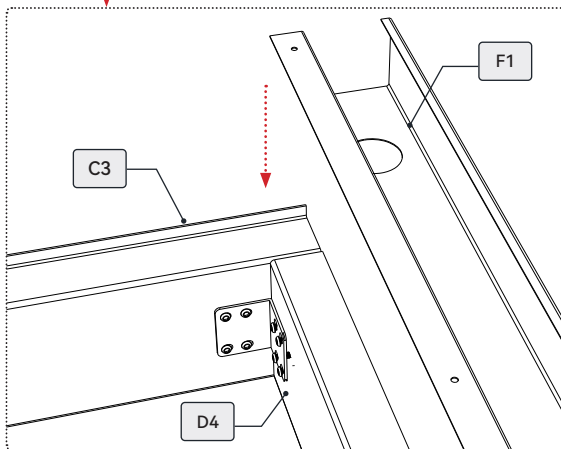
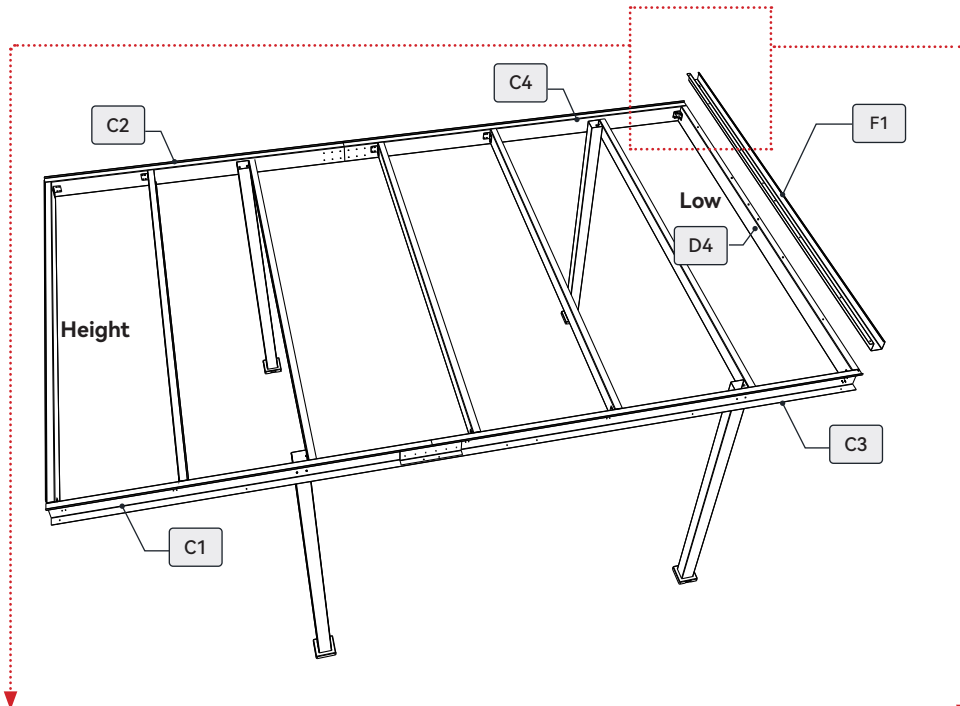
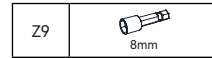
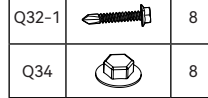
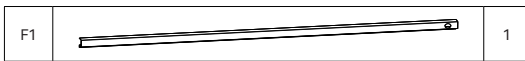

Montieren Sie die F1-Rinne gemäß der Abbildung auf der Oberseite des D4-Trägers.

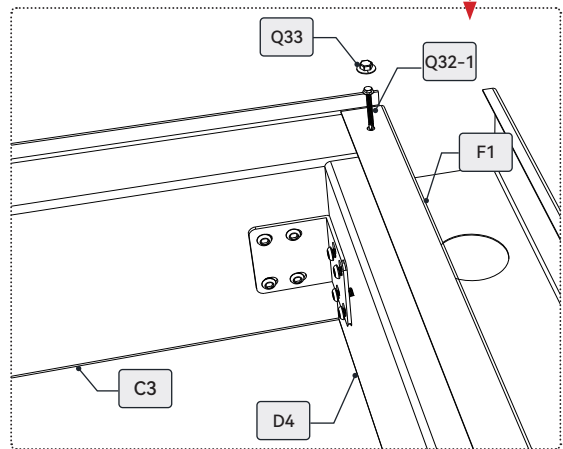

Treiben Sie Q32-1-Schrauben in die vorgebohrten Löcher der Rinne ein und verschließen Sie diese mit den Q33-Kappen.

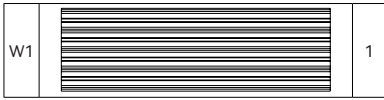

Q32	4.8x45 8mm	2
Q33		2

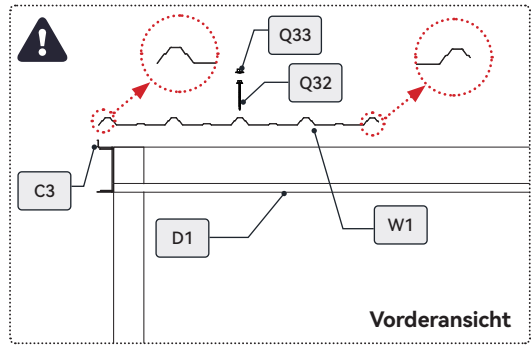
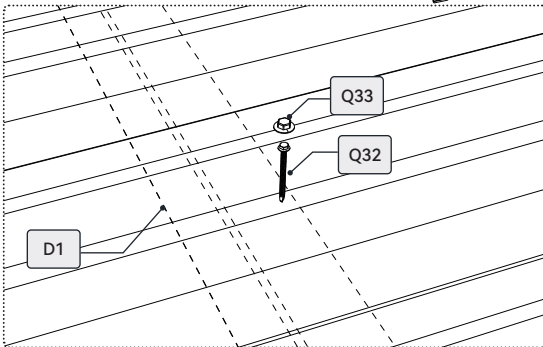
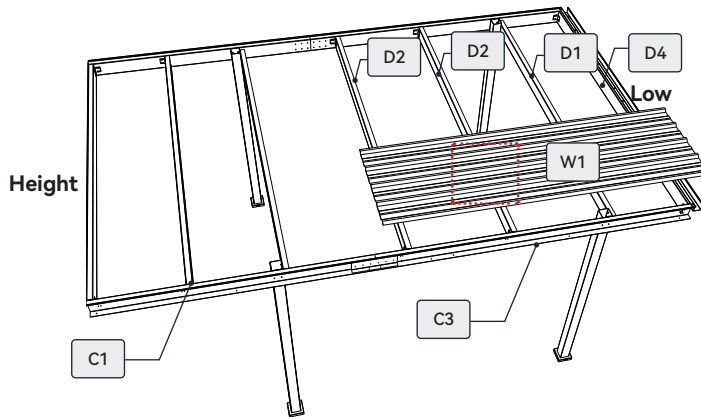

Decken Sie das Wellblech auf D1 ab, treiben Sie dann Q32-Schrauben an der markierten Stelle ein und verschließen Sie diese mit Q33-Kappen.

Achten Sie auf die unterschiedlichen Enden der Platten. Platzieren Sie sie beidseitig in der in der Abbildung gezeigten Ausrichtung.

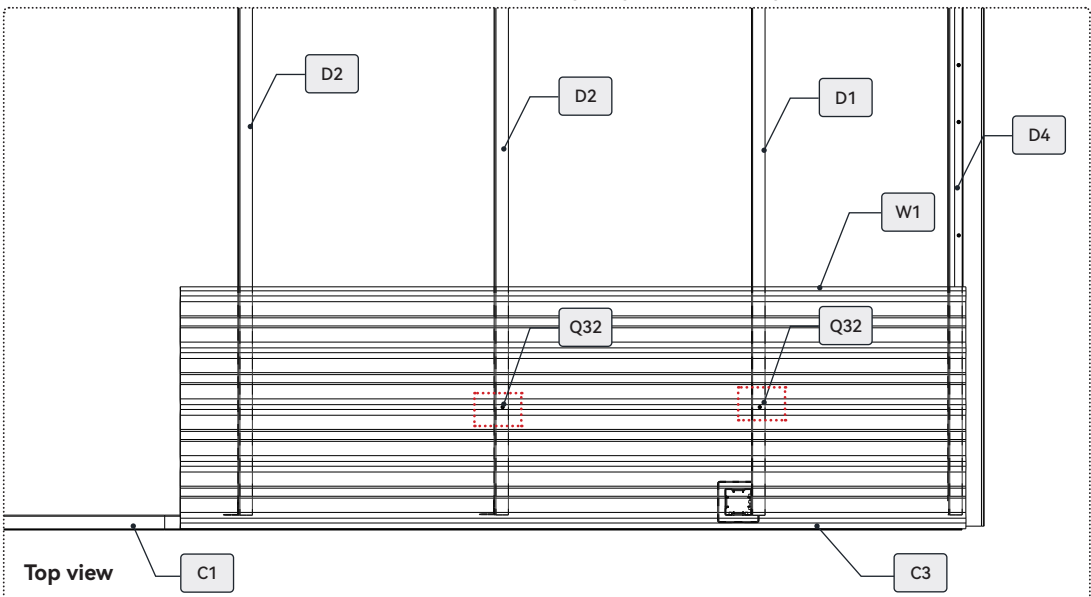

Treiben Sie an der Position der W1-Platte innerhalb des in der Abbildung gezeigten gestrichelten Rahmens Q32-Schrauben ein, um sie über den Querträgern D1/D2 zu befestigen. Beachten Sie, dass in diesem Schritt keine Schrauben in den Bereichen über D3 und C1/C3 verwendet werden sollten; diese werden erst nach der Montage des Rahmens B1/2/3/4/5 im letzten Schritt mit Schrauben fixiert, um die gesamte Struktur zu sichern.

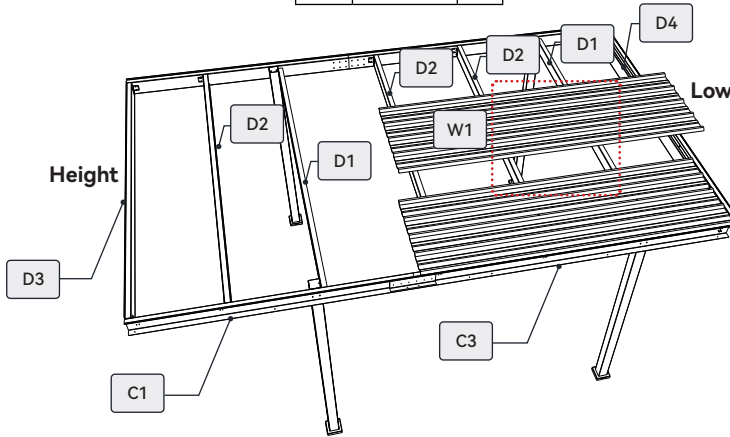
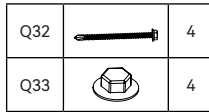
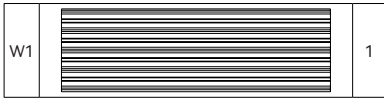

Achtung: Befestigen Sie jedes Wellblech sofort nach dem Verlegen mit Schrauben an den markierten Stellen. Andernfalls wird es schwierig, die folgenden Wellbleche zu fixieren.

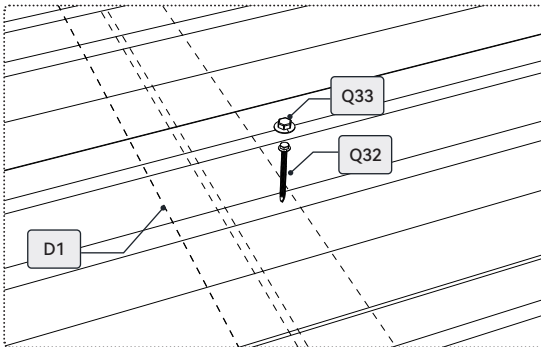

Decken Sie das Wellblech auf D1 ab, treiben Sie dann Q32-Schrauben an der markierten Stelle ein und verschließen Sie diese mit Q33-Kappen.

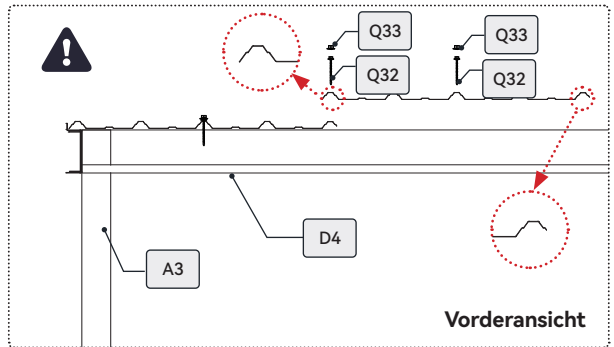

Achten Sie auf die unterschiedlichen Enden der Platten. Platzieren Sie sie beidseitig in der in der Abbildung gezeigten Ausrichtung.

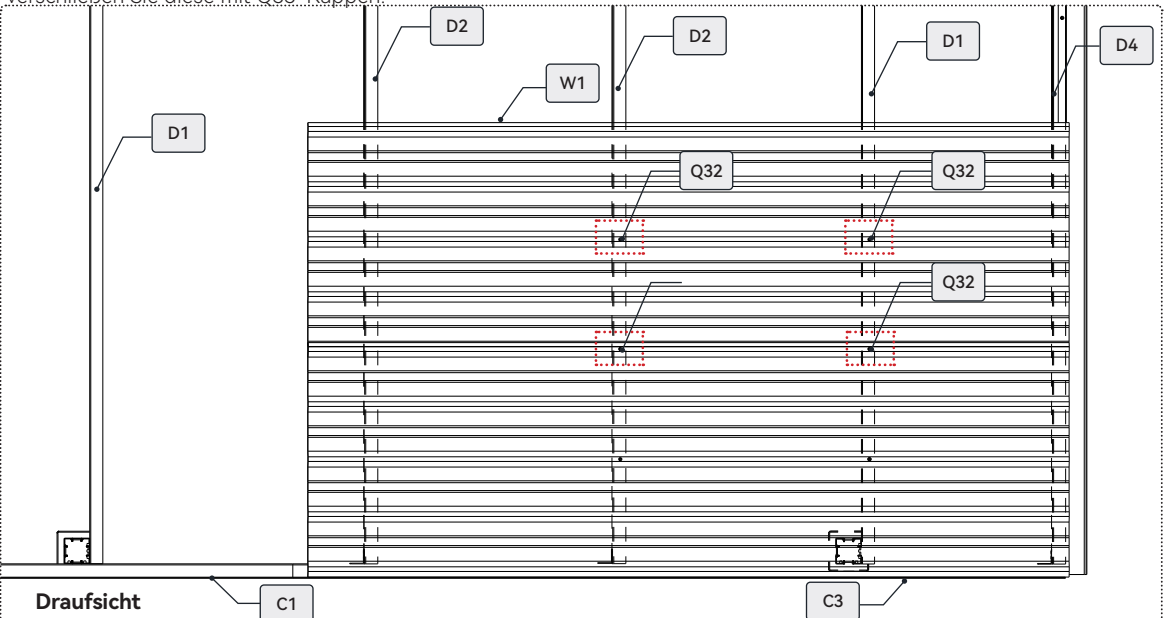

Treiben Sie an der Position der W1-Platte innerhalb des in der Abbildung gezeigten gestrichelten Rahmens Q32-Schrauben ein, um sie über den Querträgern D1/D2 zu befestigen. Beachten Sie, dass in diesem Schritt keine Schrauben in den Bereichen über D4 und C1/C3 verwendet werden sollten; diese werden erst nach der Montage des Rahmens B1/2/3/4/5 im letzten Schritt mit Schrauben fixiert, um die gesamte Struktur zu sichern.

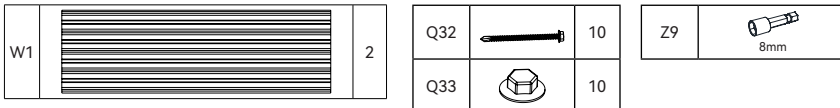

Achtung: Befestigen Sie jedes Wellblech sofort nach dem Verlegen mit Schrauben an den markierten Stellen. Andernfalls wird es schwierig, die folgenden Wellbleche zu fixieren.

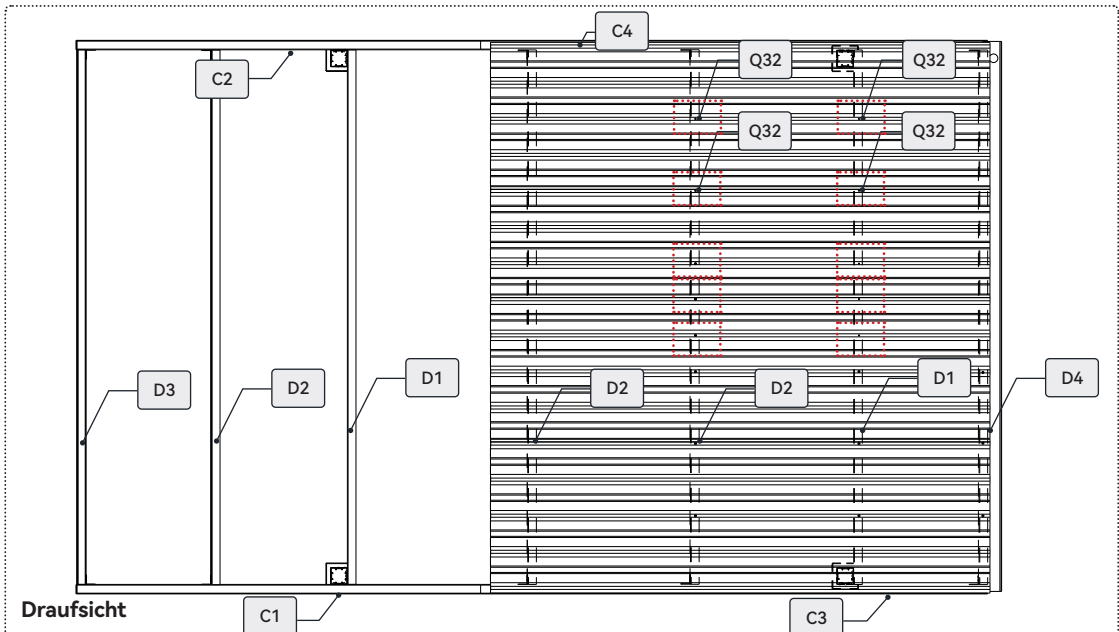
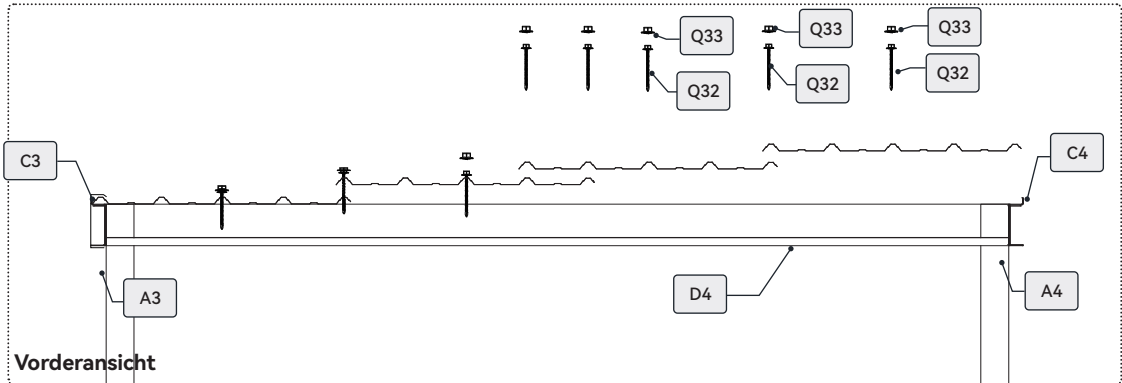
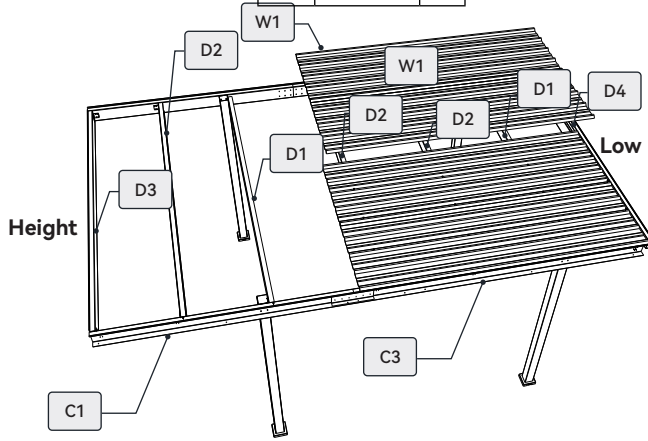

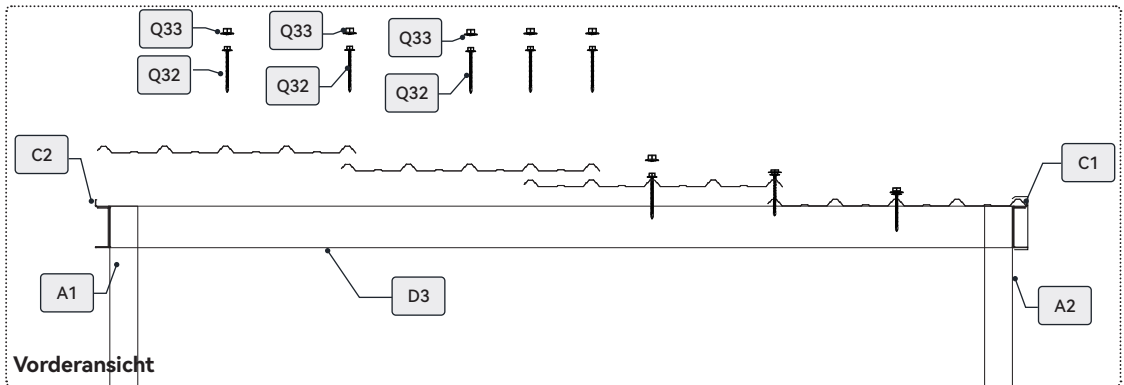
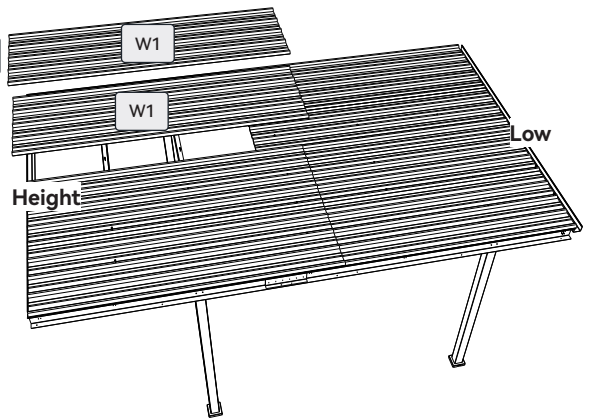
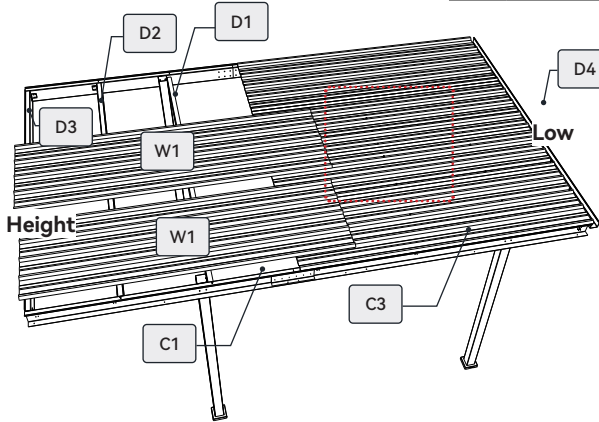
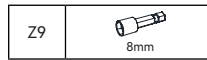
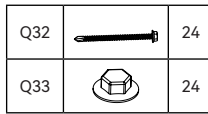

Treiben Sie an der Position der W1-Platte innerhalb des in der Abbildung gezeigten gestrichelten Rahmens Q32-Schrauben ein, um sie über den Querträgern D1/D2 zu befestigen. Beachten Sie, dass in diesem Schritt keine Schrauben in den Bereichen über D4 und C1/C3 verwendet werden sollten; diese werden erst nach der Montage des Rahmens B1/2/3/4/5 im letzten Schritt mit Schrauben fixiert, um die gesamte Struktur zu sichern.



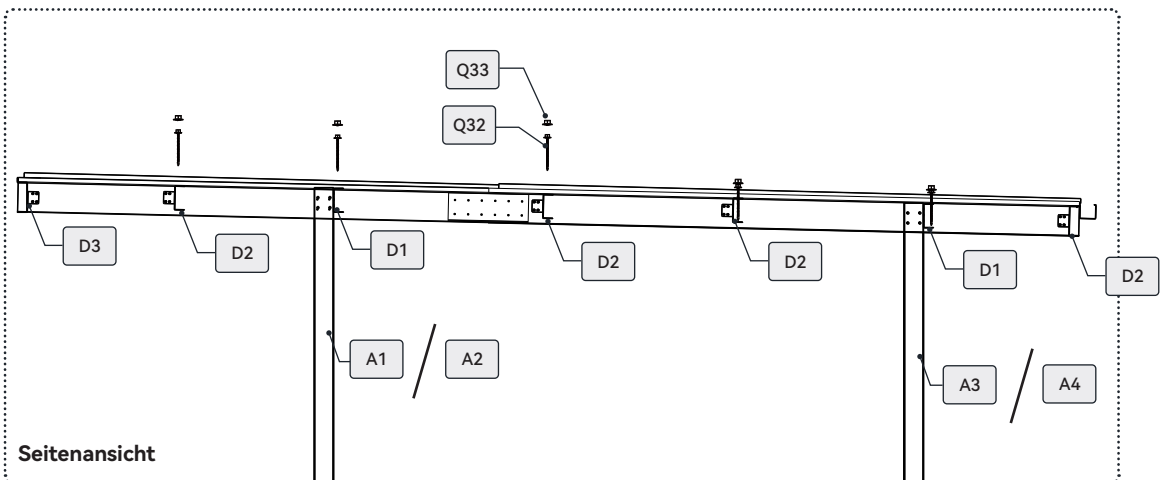

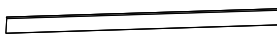

Achtung: Befestigen Sie jedes Wellblech sofort nach dem Verlegen mit Schrauben an den markierten Stellen. Andernfalls wird es schwierig, die folgenden Wellbleche zu fixieren.



Treiben Sie an der Position der W1-Platte innerhalb des in der Abbildung gezeigten gestrichelten Rahmens Q32-Schrauben ein, um sie über den Querträgern D1/D2 zu befestigen. Beachten Sie, dass in diesem Schritt keine Schrauben in den Bereichen über D4 und C1/C3 verwendet werden sollten; diese werden erst nach der Montage des Rahmens B1/2/3/4/5 im letzten Schritt mit Schrauben fixiert, um die gesamte Struktur zu sichern.

B2		1
B4		1

Q20-2		6x16	4mm	7
Q32-1				6
Q33				6

Z3		4mm
Z4		4mm

Z9		8mm
----	---	-----

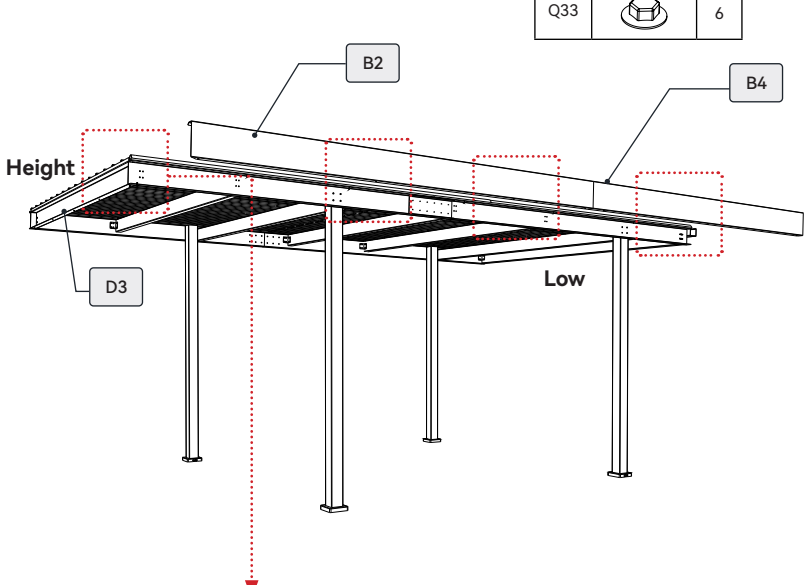

Height

Low

B2

B4

D3

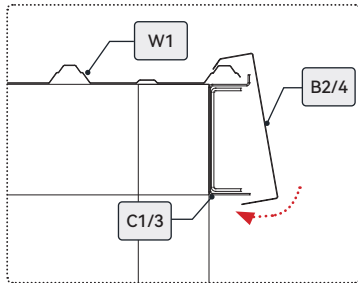

W1

B2/4

C1/3

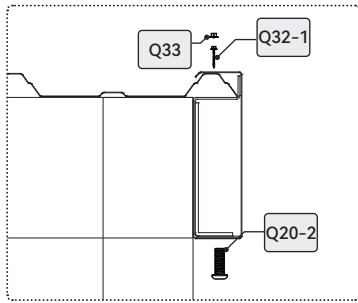

Q33

Q32-1

Q20-2

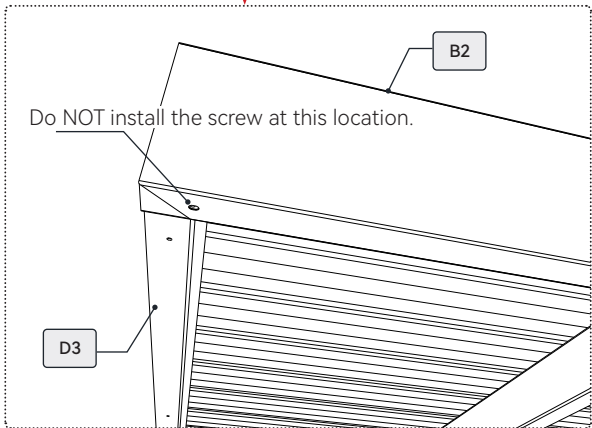

Do NOT install the screw at this location.

B2

D3

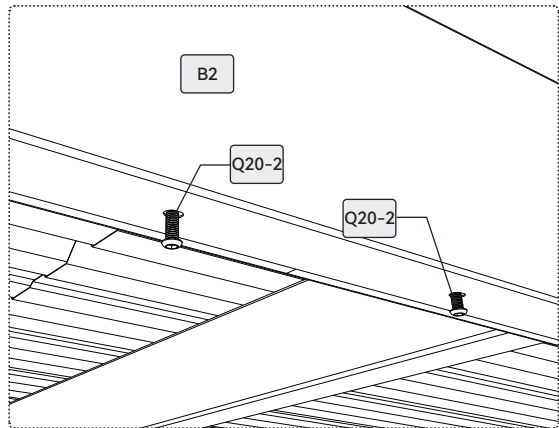

B2

Q20-2

Q20-2

Treiben Sie Q20-2-Schrauben in den Boden von B2/B4 ein, um den Rahmen am Träger zu befestigen.

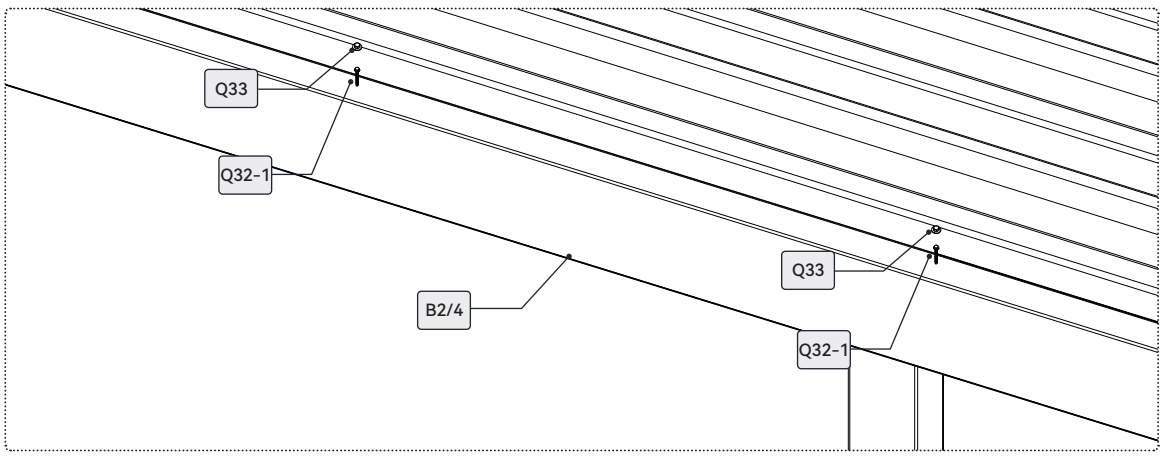









Q33

Q32-1

B2/4

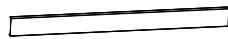
Q33

Q32-1

B3		1	Q20-2		7	Z3		Z9	
B5		1	Q32-1		6	Z4			
			Q33		6				

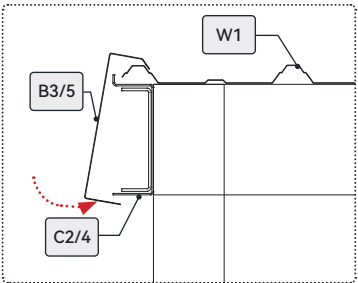

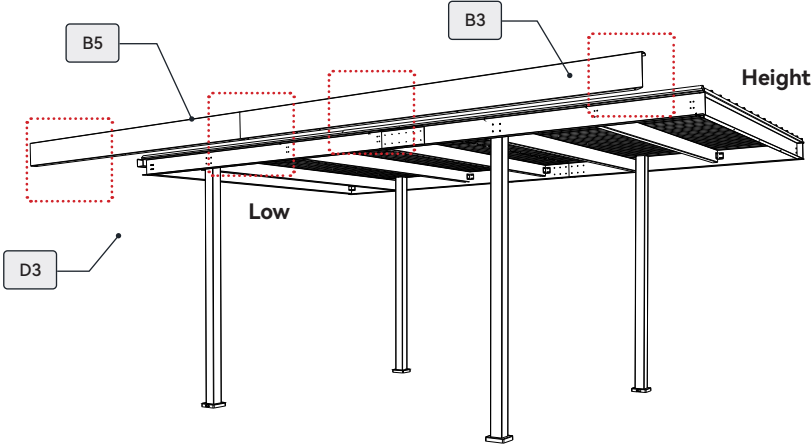

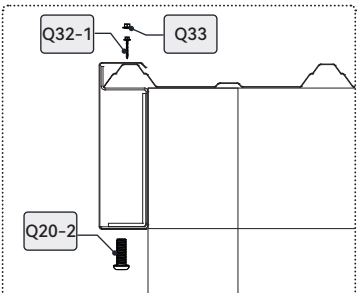

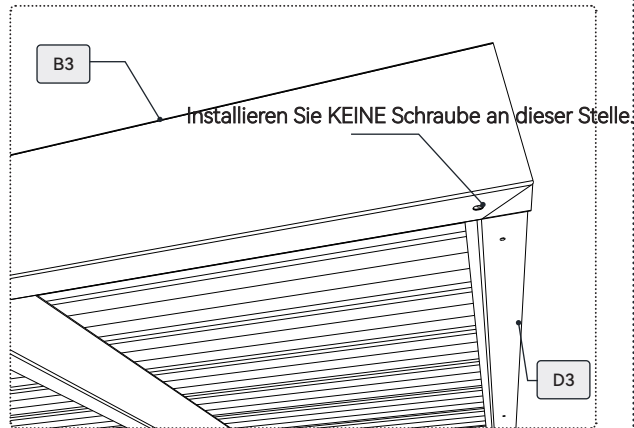
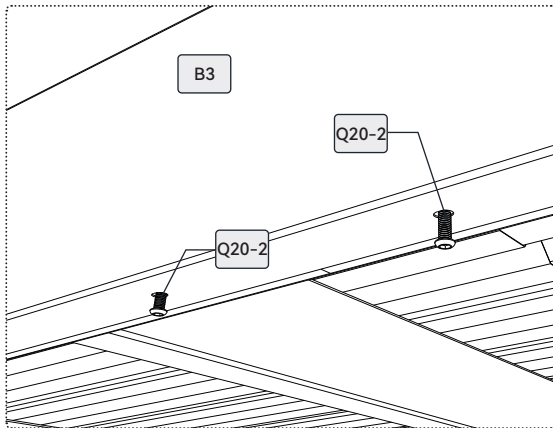

Treiben Sie Q32-1-Schrauben in die Oberseite von B2/B4 ein, ausgerichtet mit den Q32-Schrauben entlang derselben Linie.

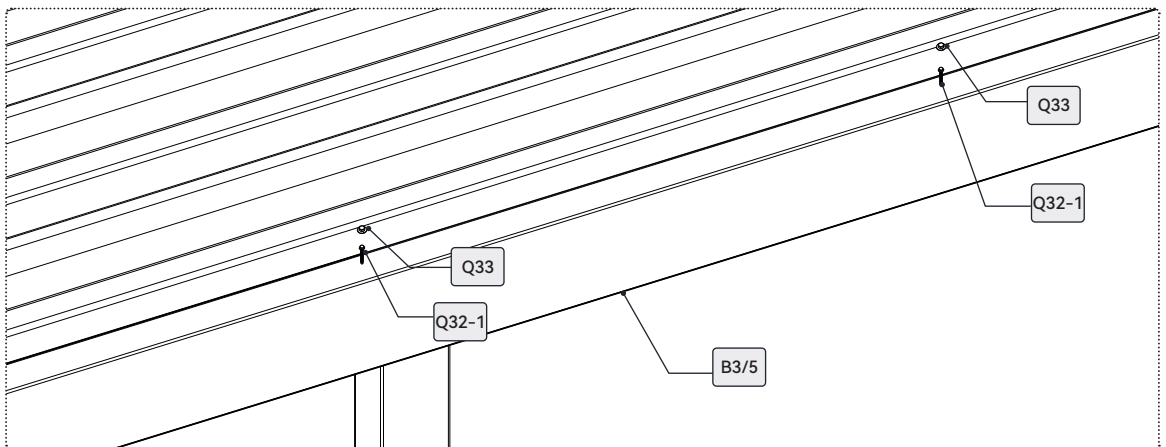

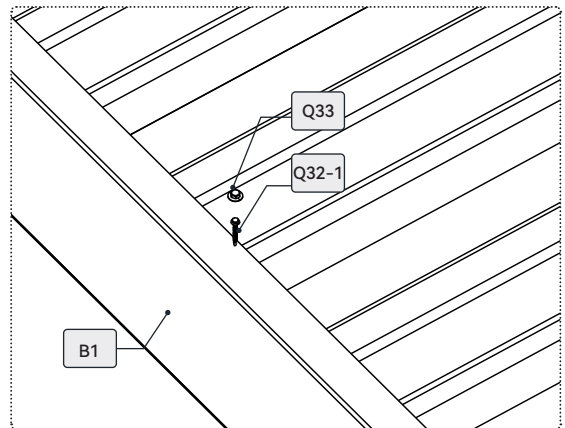
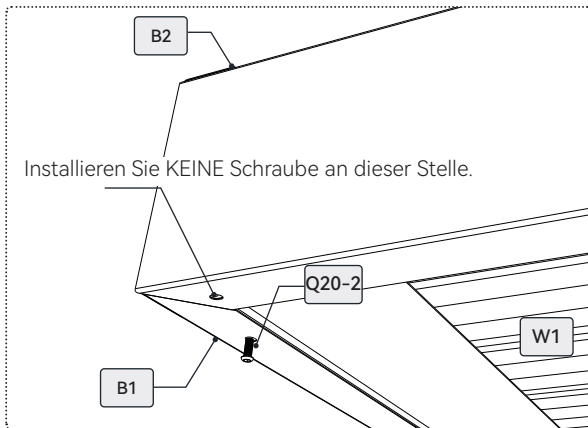
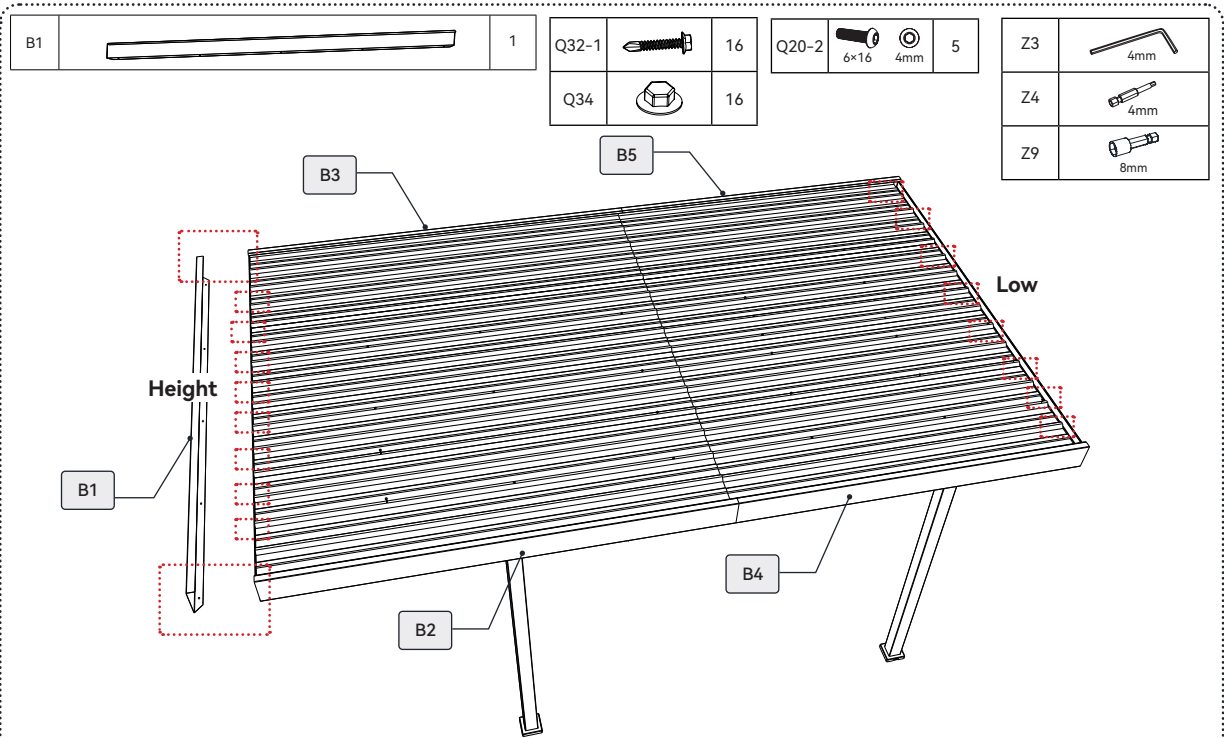

Treiben Sie Q32-1-Schrauben an den in der Abbildung gezeigten Positionen in B1 ein und verschließen Sie diese mit Q33-Kappen.

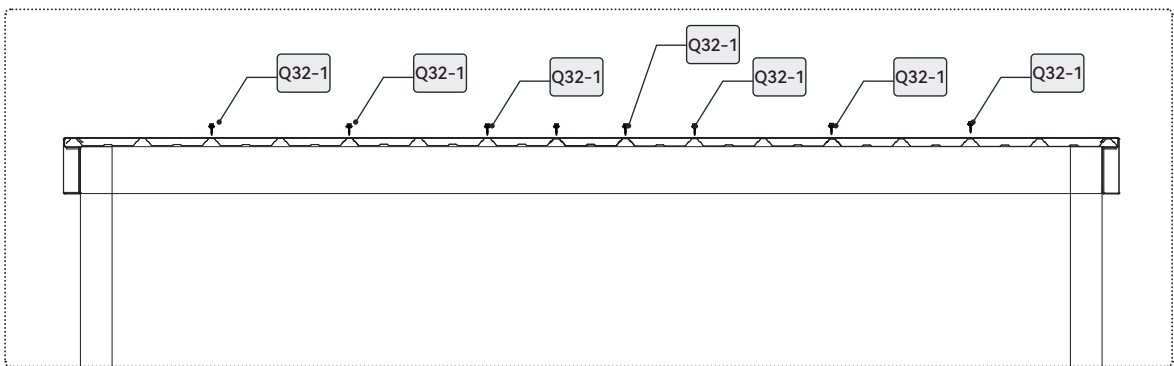

T1		1
----	--	---

T2		1
----	--	---

Q32-1		4
Q34		4



Q20-2		6x16	4mm	2
-------	--	------	-----	---



Z3		4mm
----	--	-----

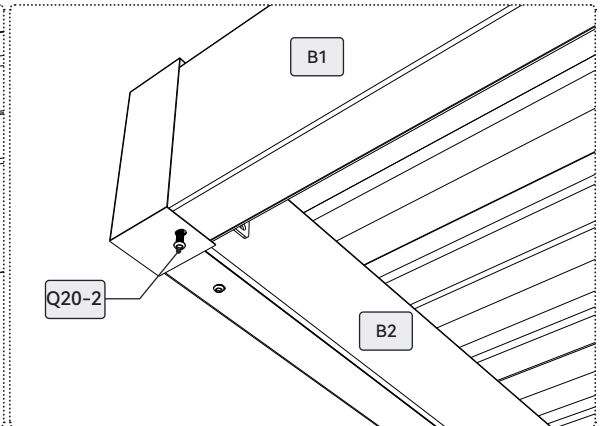
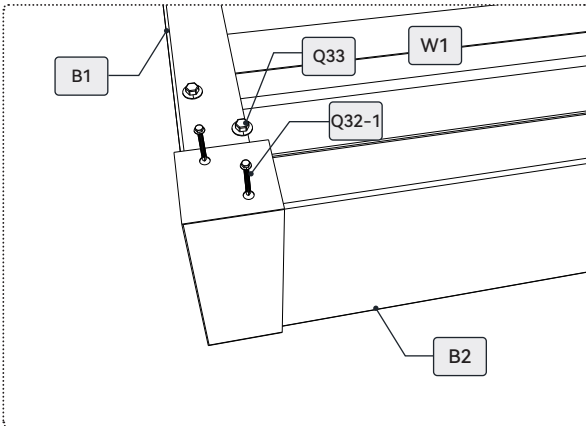
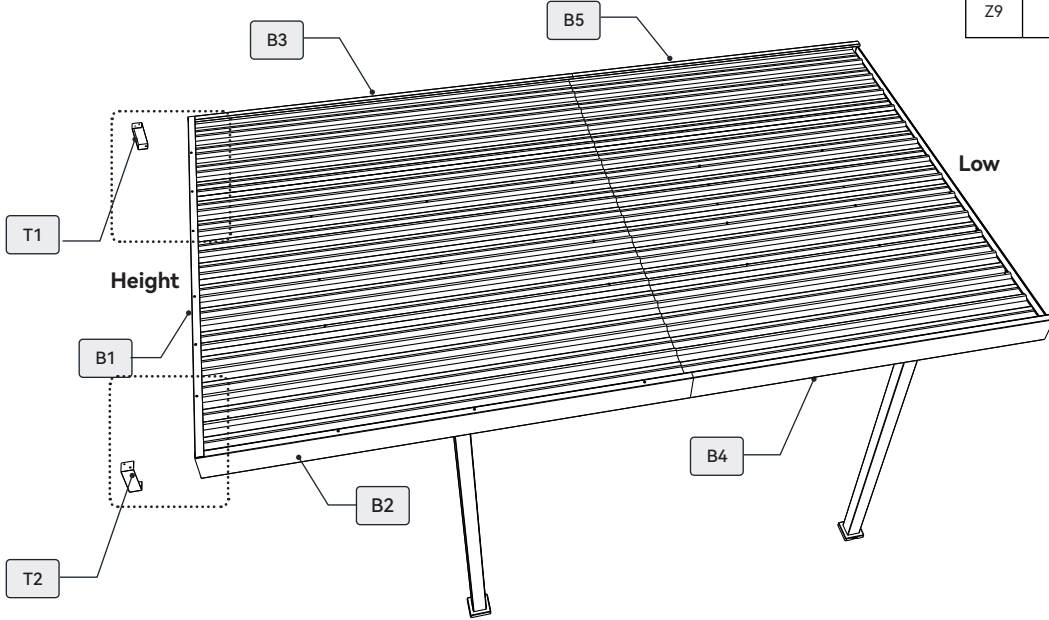

Z4		4mm
----	--	-----

Z9		8mm
----	--	-----



E1		1
E2		1
E3		1

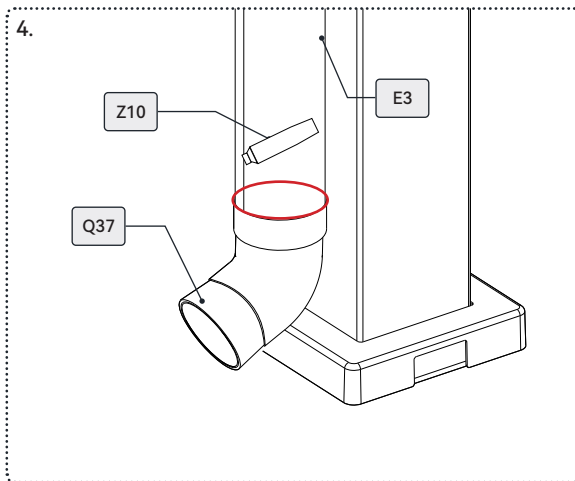
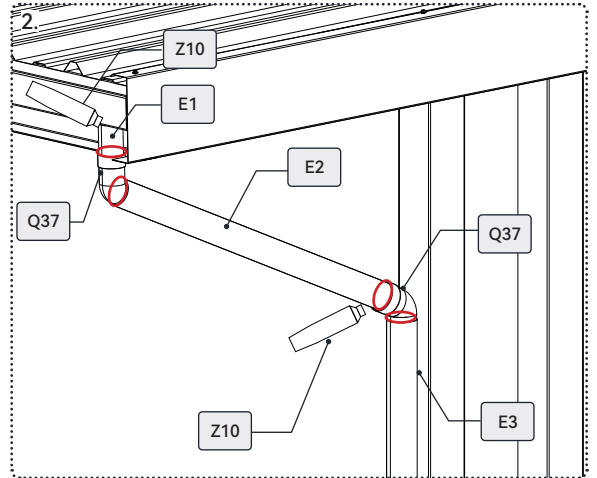
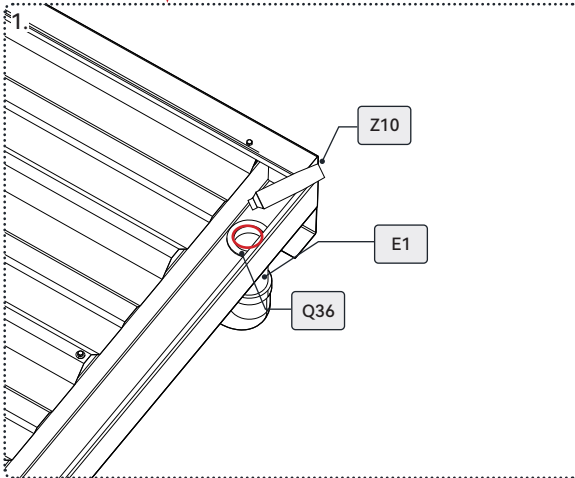
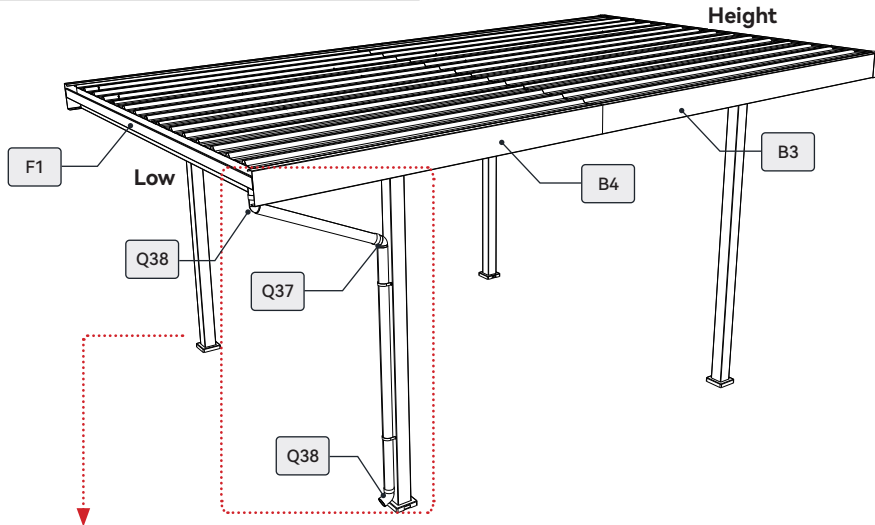

Q36		1
Q37		3

Z9		8mm
Z10		



Attention:

Waterproof sealant must be applied at the water pipe connections.

Q35		2
WO-1	 	4

Z9	
	8mm

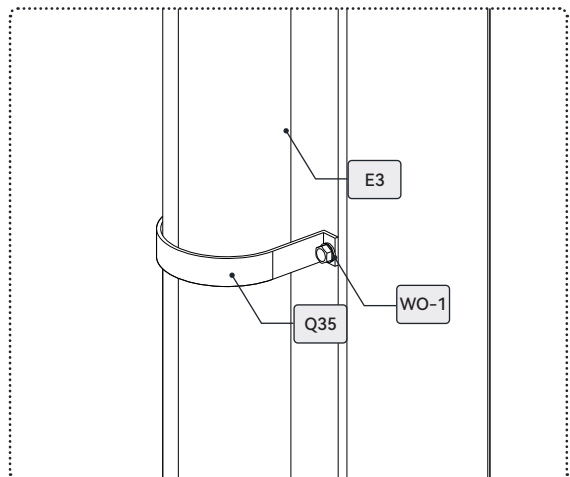
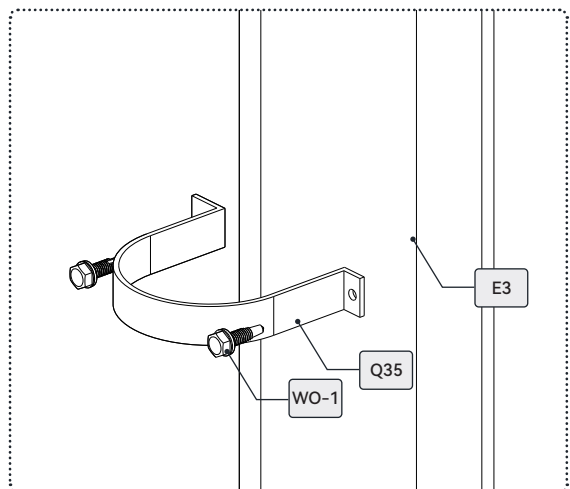
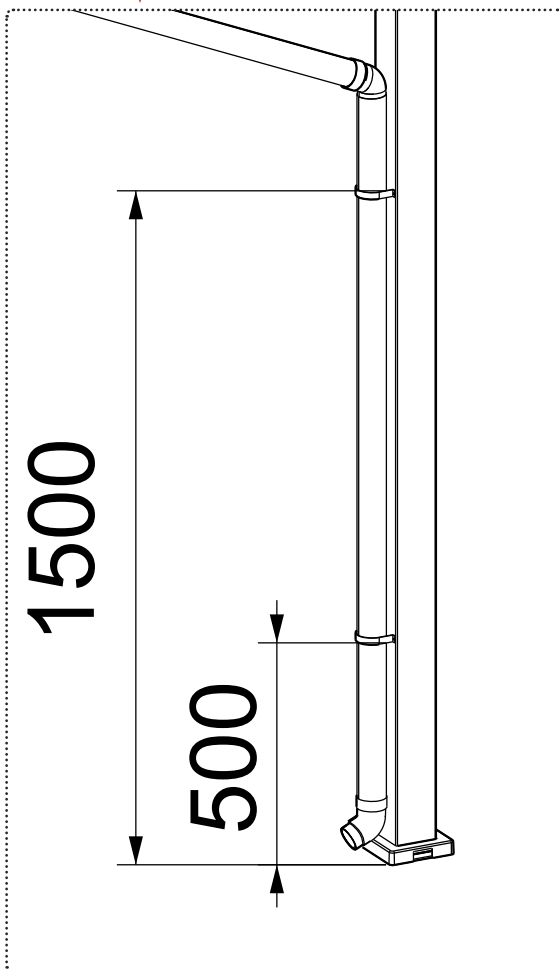
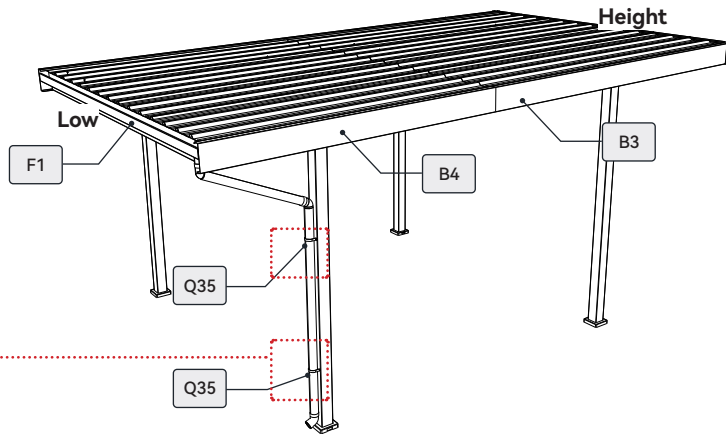

ALL-IRON CARPORT

ASSEMBLY INSTRUCTIONS

3000 X 5300



We appreciate your purchase of our Carport.

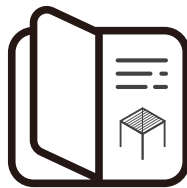

Instruction Manual

This guide will give you step-by-step instructions on how to assemble and care for your pergola, ensuring it lasts for years of enjoyment and reliable use.

IMPORTANT:

Warning: Safety Instructions

For the safety of individuals, it is crucial to follow these instructions. Please retain them for future reference.

Children and individuals with disabilities or limited experience may use the appliance if they are properly supervised or trained and understand the potential risks.

Children should not be allowed to play with the appliance. Cleaning and maintenance tasks should only be performed by children under supervision.

This pergola is designed for outdoor residential use, providing protection from direct sunlight, glare, and heat.

Any use or modification not outlined in this manual is considered improper and could pose significant risks to both users and property. Such actions will void the product warranty.

Before the Installation

PREPARE ALL THE NECESSARY TOOLS

To assemble your pergola properly and safely, make sure you have the following tools and accessories on hand, as these are not included.



2 step ladders



Protective gloves



Hexagonal spanner/wrench set



Phillips screwdriver



Hammer



Tape measure



Hard hat



Box cutter



Hammer drill



Spirit level



Cordless screwdriver



Scissors

CHECK FOR MISSING PARTS:

Before starting the installation, verify that you have all the necessary parts to assemble your e-Motion. Double-check that the quantity of parts matches the model you purchased.

If any parts are missing, please reach out to customer service before proceeding with the installation.

PREPARE THE PARTS FOR EACH STEP:

In the Installation section of the manual, each step specifies the parts and quantities needed. We recommend gathering the necessary parts ahead of time for each step. This will help save you time and make the assembly process smoother. To avoid damaging the painted surfaces, place the parts on cardboard or another soft surface if possible.

CHOOSE AN APPROPRIATE LOCATION:

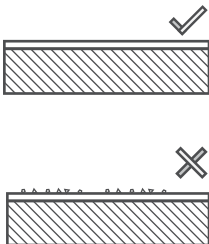
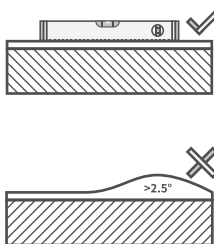
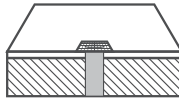
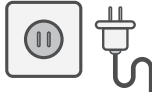
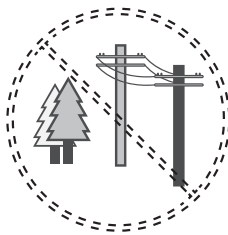
				
The ground should be solid and level.	The ground must be flat and even.	Ensure there is adequate water drainage in the area.	Make sure the location has easy access to power, if needed	Avoid areas with overhanging trees or powerlines.

WARNING:

Many terraces or patios are built with a slight slope to direct rainwater away from the house or other structures. For proper pergola installation, a completely level surface is required. Small pebbles or uneven ground may prevent the pergola from being securely anchored.

If the pergola is installed on an uneven surface, it may affect the performance of accessory components and could void the product warranty. You may also need to adjust the height of the pillars for proper installation.

PREPARE THE FOUNDATION:

To get your foundation ready, make sure to:

Check for underground pipes and cables (call local relative authorities before digging).

Verify with local authorities if any building permits are necessary.

If you're opting for a concrete base, consult with a reputable contractor.





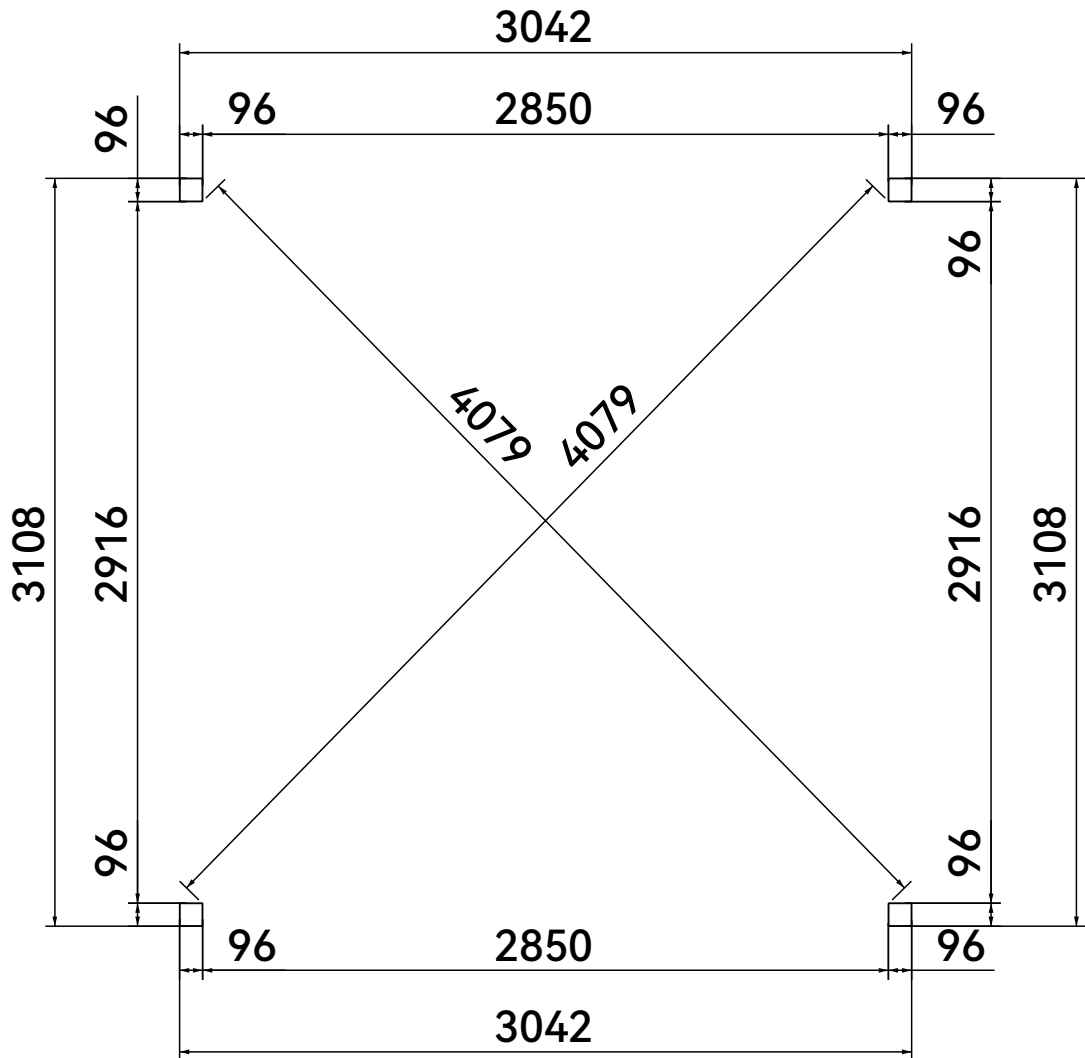



Pergola Size

Plane size







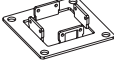

Spare Parts List

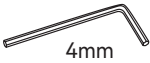

CARTON 1/8

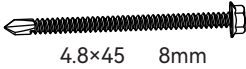
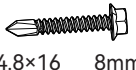
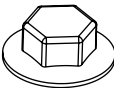

No.	Profile	Diagram	Size	QTY
A1			96X96 L=2371mm	1
A2			96X96 L=2371mm	1
A3			96X96 L=2294mm	1
A4			96X96 L=2294mm	1

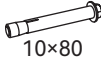

No.	Diagram	QTY
Q1-1		4
Q2-1		4

No.	Diagram	QTY
Z3		1
Z4		1

No.	Diagram	QTY
Q20-2		161
Q31		4
Q32		40
Q32-1		30
Q33		70
Q34		10







No.	Diagram	QTY
Q15		16
Q20-2		32

No.	Diagram	QTY
Z9		1
Z10		1

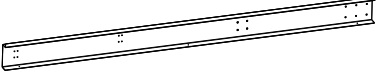



No.	Diagram	QTY
Q35		2
Q36		1
Q37		3

Spare Parts List









CARTON 2/8

No.	Profile	Diagram	Size	QTY
C1			55X163 L=2350mm	1
C2			55X163 L=2350mm	1
C3			55X163 L=2950mm	1
C4			55X163 L=2950mm	1

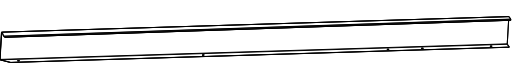

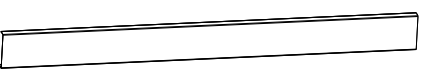

CARTON 3/8

No.	Profile	Diagram	Size	QTY
D3			50X173 L=3110mm	1
D4			50X150 L=3110mm	1

CARTON 4/8







No.	Profile	Diagram	Size	QTY
B2			50X178 L=2952mm	1
B3			50X178 L=2952mm	1
B4			50X178 L=2430mm	1
B5			50X178 L=2430mm	1
C-1			400X140 L=400mm	2





CARTON 5/8

No.	Profile	Diagram	Size	QTY
D1			50X120 L=3110mm	2
D2			50X120 L=3110mm	2

Spare Parts List

CARTON 6/8

No.	Profile	Diagram	Size	QTY
D2			50X120 L=3110mm	1
F1			109X70 L=3210mm	1
B1			50X180 L=3214mm	1

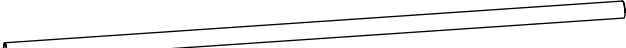
No.	Profile	Diagram	Size	QTY
E1			50X50 L=90mm	1
E2			50X50 L=790mm	1
E3			50X50 L=1680mm	1

No.	Diagram	QTY
T1		1

No.	Diagram	QTY
T2		1

CARTON 7/8

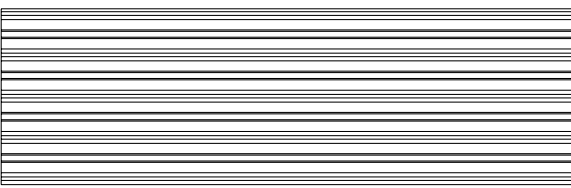
No.	Profile	Diagram	Size	QTY
W1			25X890 L=2750mm	4

CARTON 8/8

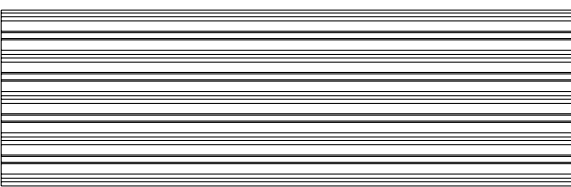
No.	Profile	Diagram	Size	QTY
W1			25X890 L=2750mm	4

Spare Parts List

Before proceeding with the assembly of your louvered pergola, it is necessary to check that all parts listed are supplied and not damaged.

Any missing part must be reported within 10 days of delivery.

Do not discard the packaging without ensuring that the product is functioning properly.

A1		1
A2		1
A3		1
A4		1

Q1-1		4
Q2-1		4

Q20-2		6x16	4mm	32
-------	--	------	-----	----

Z3		4mm
Z4		4mm

Attention:

Please fasten the screw by hand after installing these screws.

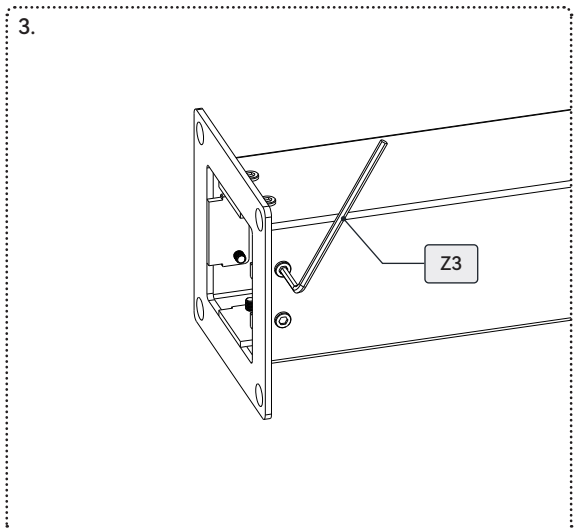
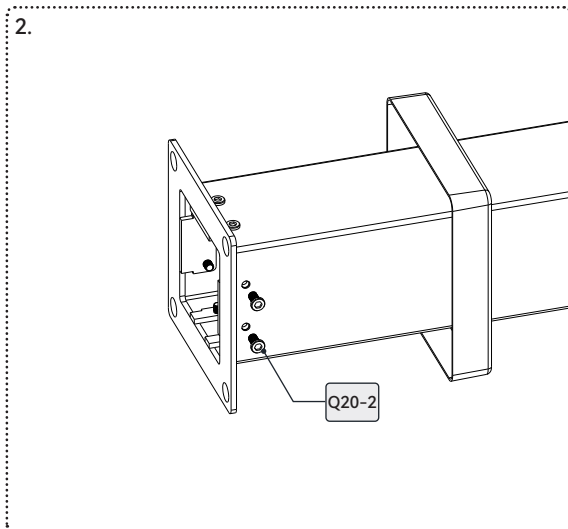
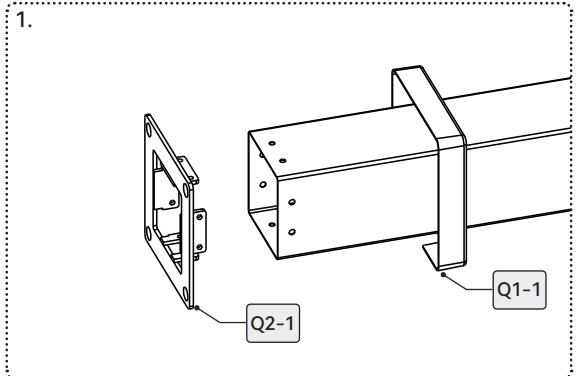
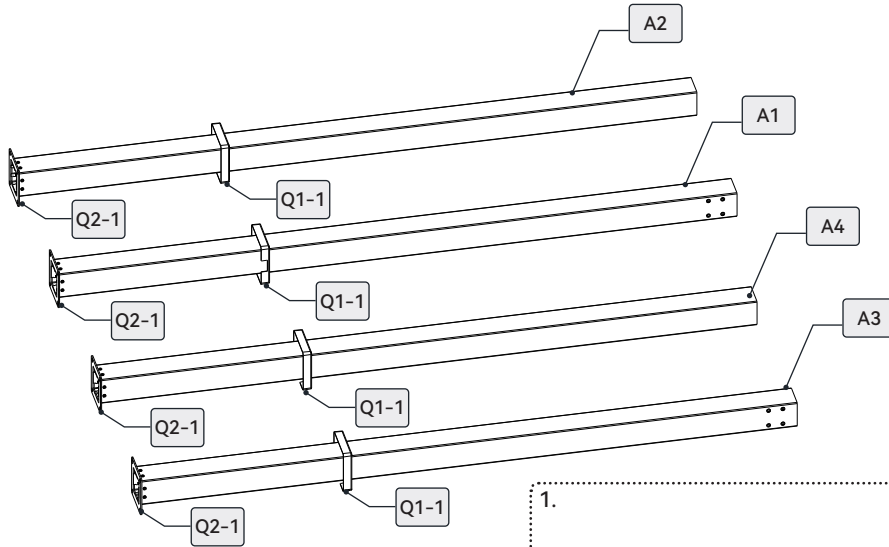

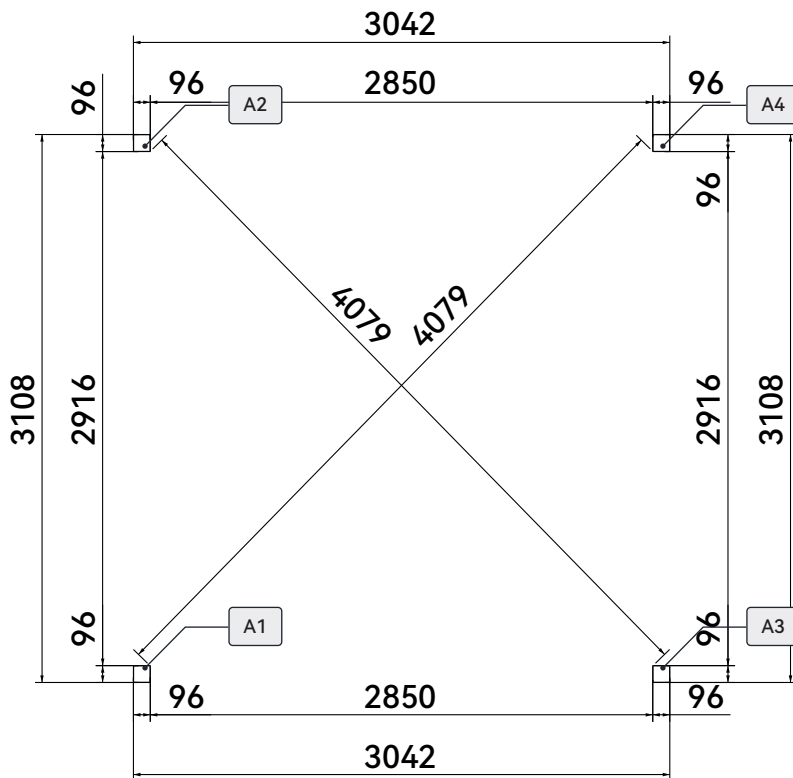
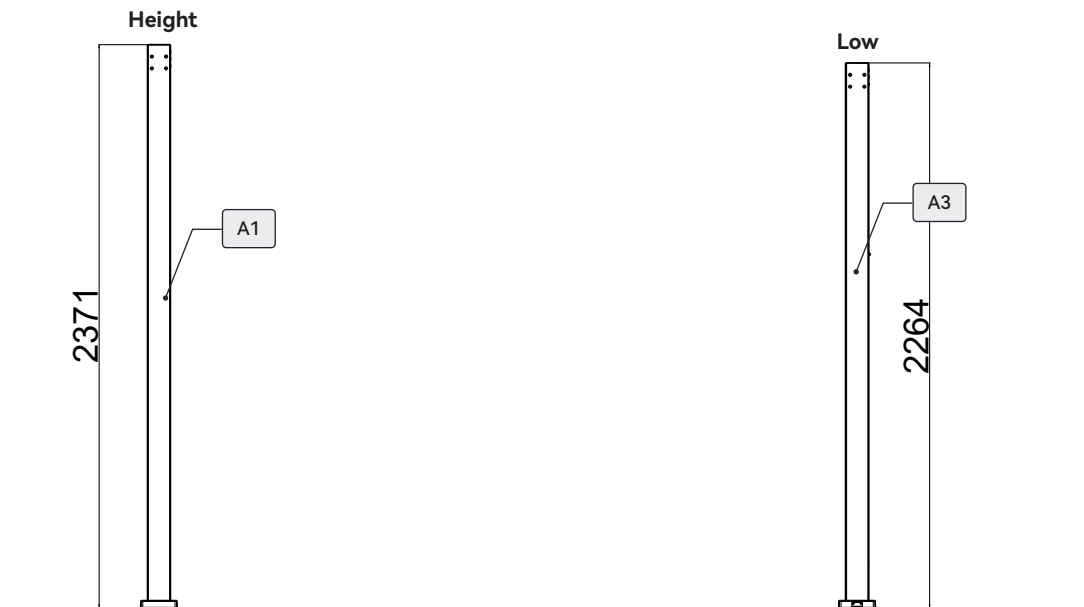

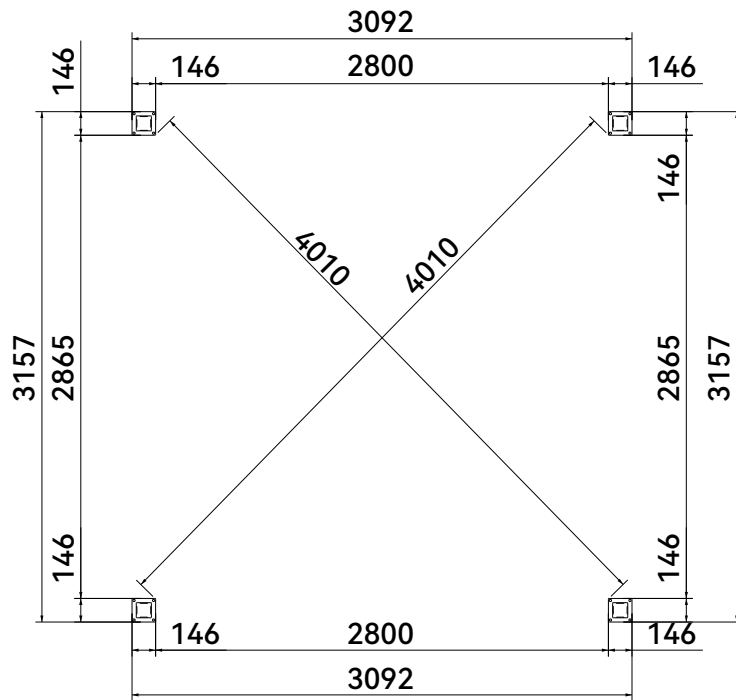

1.

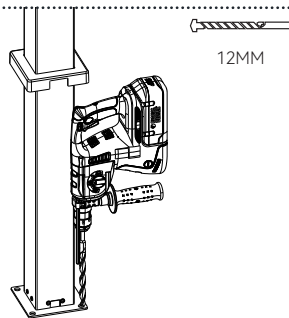

1. Use a 12 mm hammer drill to drill the holes.

2.

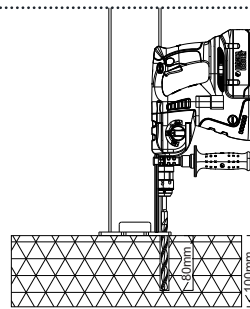

2. Extend downward by 100mm.

3.

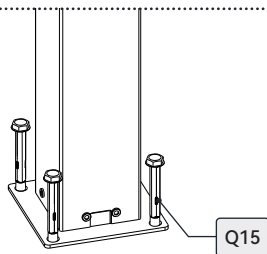





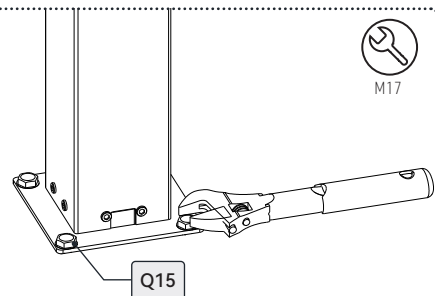

3. Drive the expansion screw in with a hammer.



4.



4. Insert the expansion bolts and tighten them with an M17 wrench.

C1		1
C2		1
C3		1
C4		1
C-1		2

Q20-2		6x16		4mm	24
-------	---	------	--	-----	----

Z3		4mm
Z4		4mm

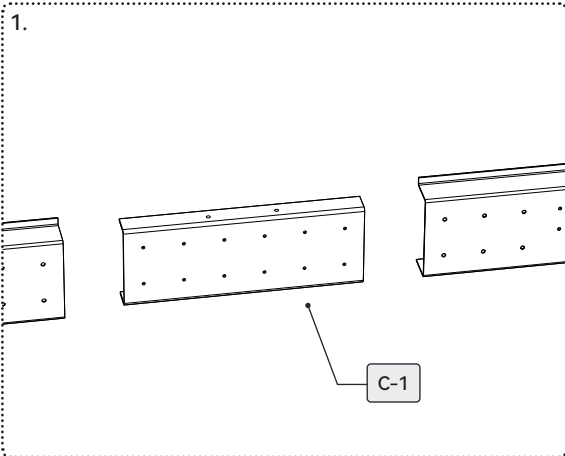
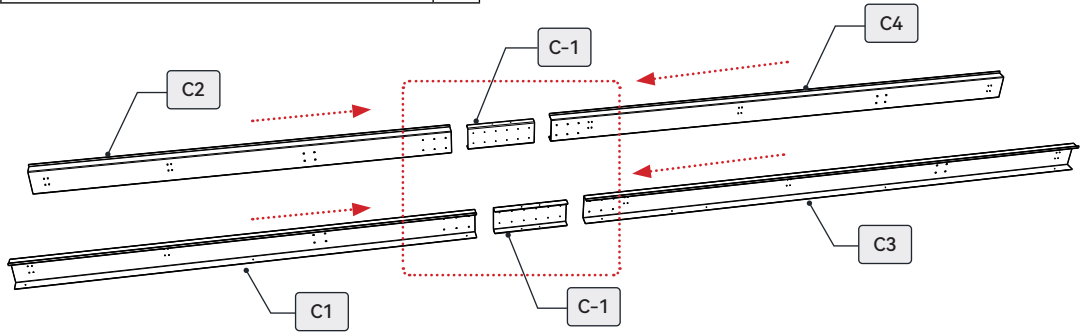

1. Use C-1 accessories to join the C2 and C4 beams, as well as the C1 and C3 beams. Note that the base plate of C-1 should be placed on the upper side of the beams.

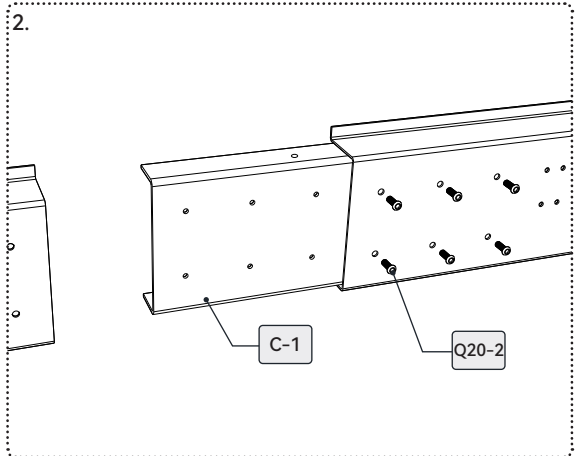

2. Drive Q20-2 screws to secure the accessory to the beam.

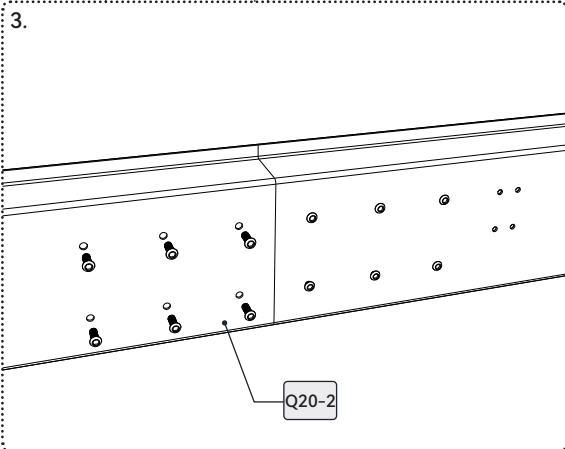

Similarly, use Q20-2 screws to secure the beam on the other side.

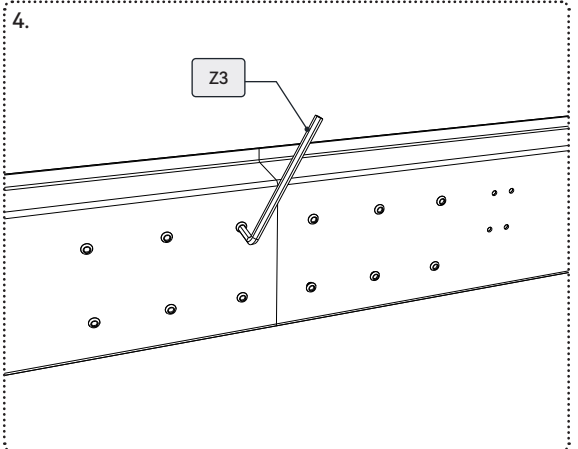

Use tool Z3 to tighten the screws.

6.

Installation Process

D1		2
----	---	---

Q20-2		6x16	4mm	20
-------	---	------	-----	----

Z3		4mm
----	---	-----

Z4		4mm
----	---	-----

Fasten beam D1 directly to the side of the column with the five pre-drilled holes.

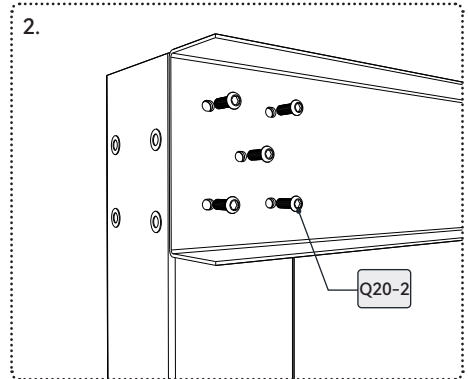
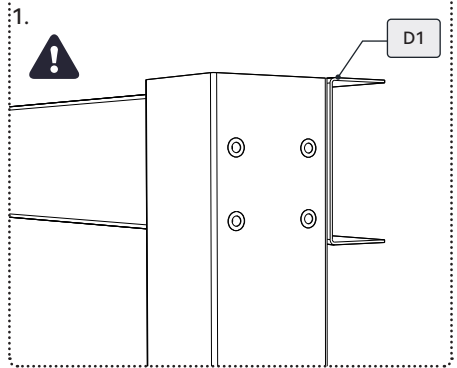
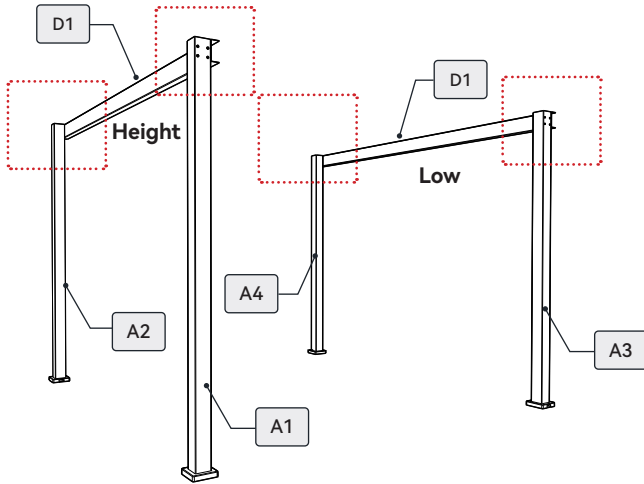

6.

Fasten beam D1 directly to the side of the column with the five pre-drilled holes.



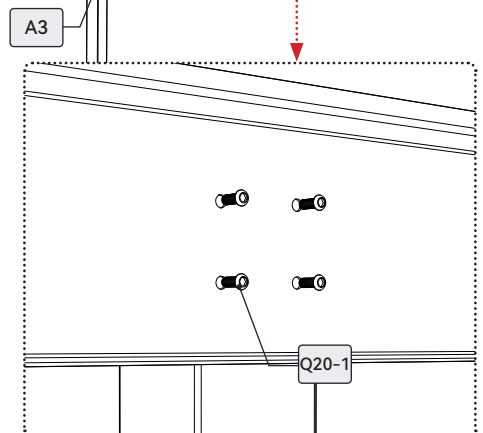
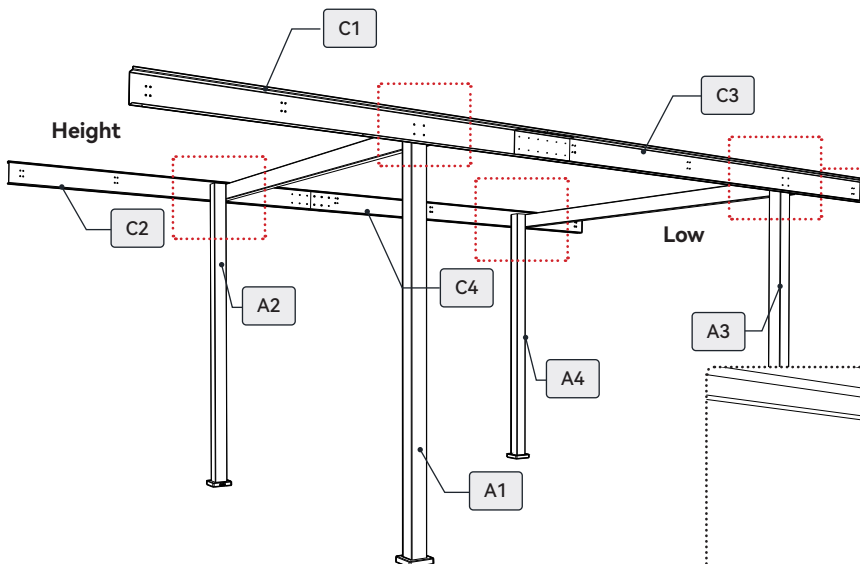

Q20-2		6x16	4mm	16
-------	---	------	-----	----

Z3		4mm
----	---	-----

Z4		4mm
----	---	-----



D2		3
----	---	---



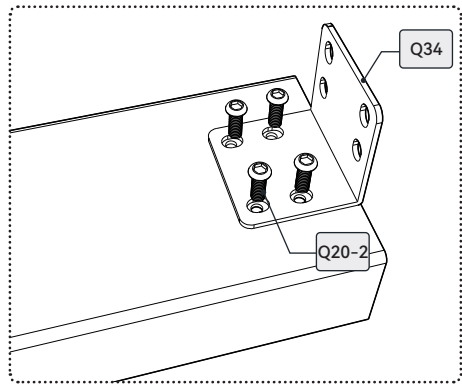
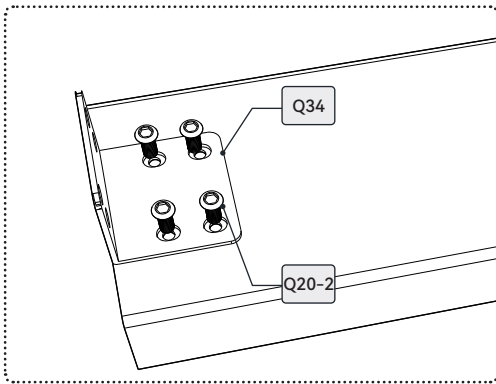
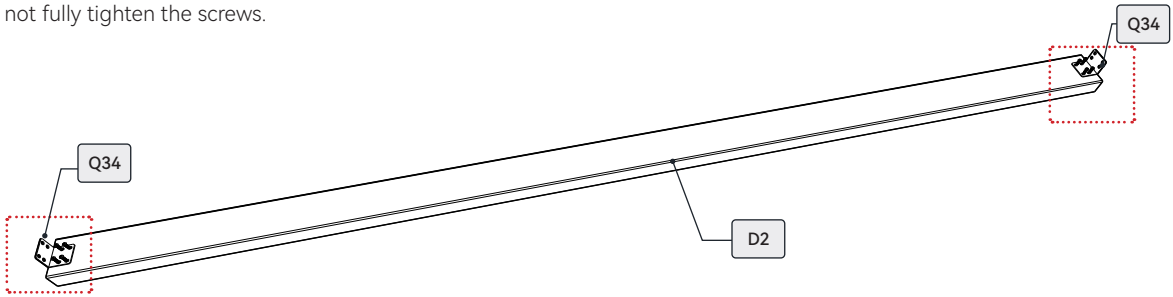

Q20-2			24	Z3		4mm
Q34			6	Z4		4mm

Attention:

Do not fully tighten the screws.



Mount the D2 sub-beam, with the Q34 beam accessory pre-installed, onto the main beam.

Q20-2			24	Z3		4mm
				Z4		4mm

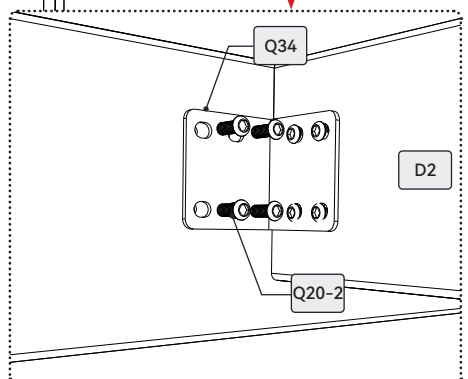
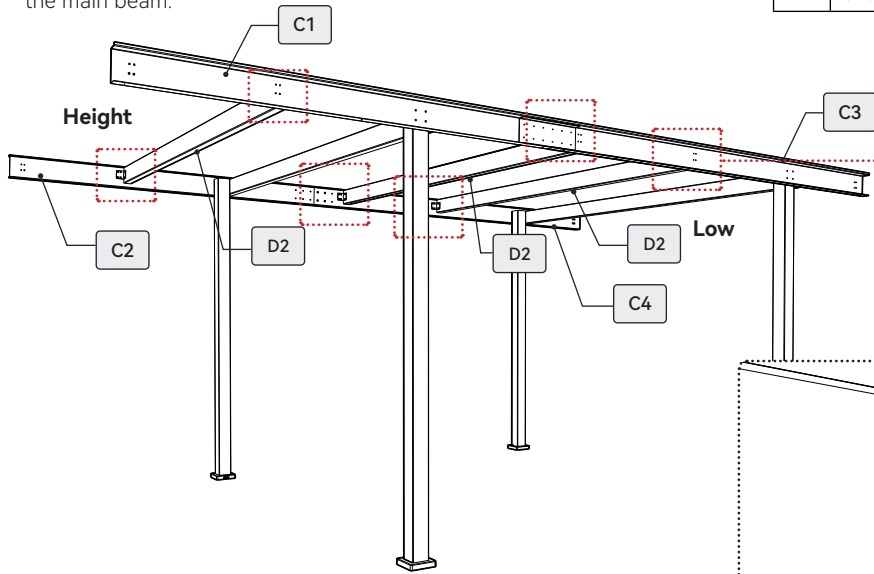

D3		1
----	---	---



Q20-2		6x16		4mm	8	Z3		4mm
Q34					2	Z4		4mm

Attention:

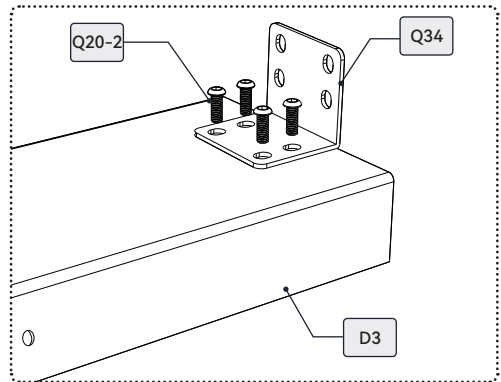
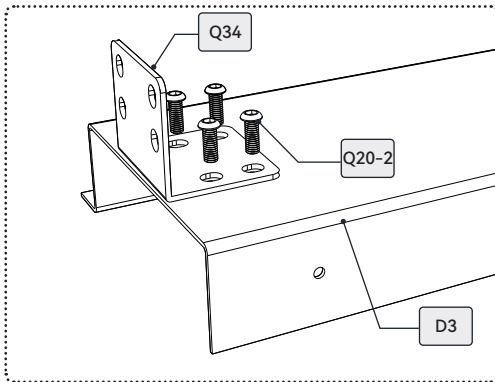
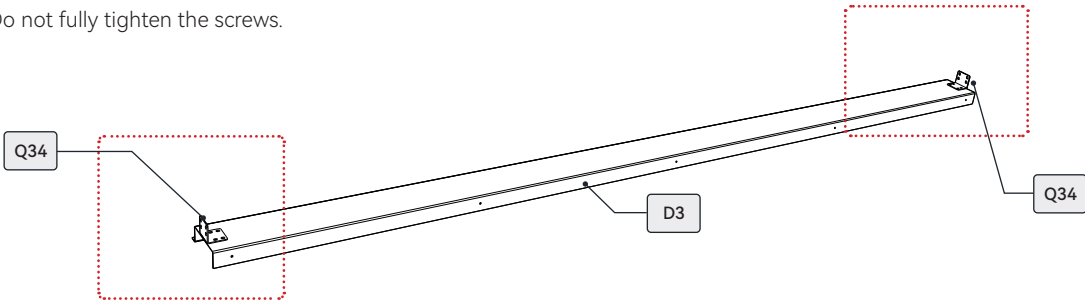
Do not fully tighten the screws.



Q20-2		6x16		4mm	8
-------	---	------	---	-----	---

Z3		4mm
Z4		4mm

Mount the D3 sub-beam, with the Q34 beam accessory pre-installed, onto the main beam.

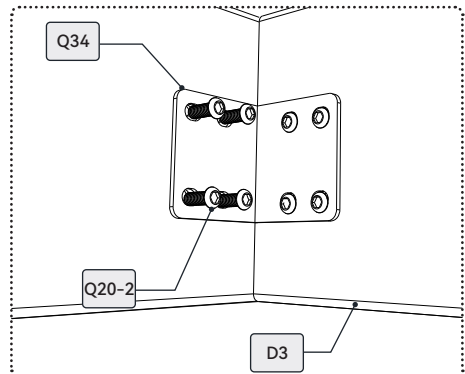
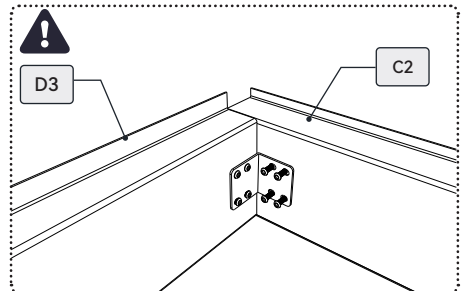
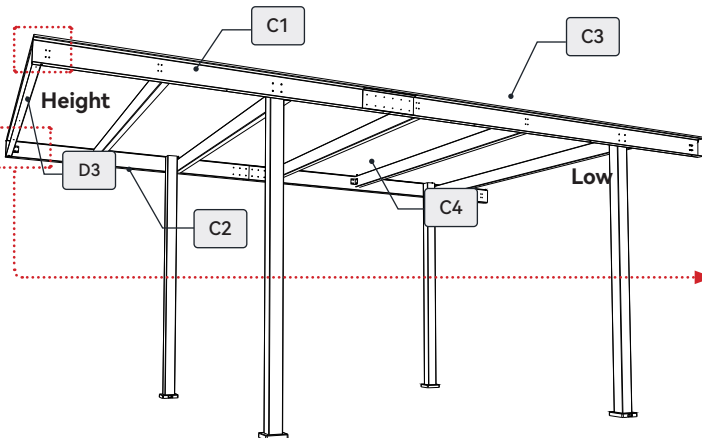





Installation Process

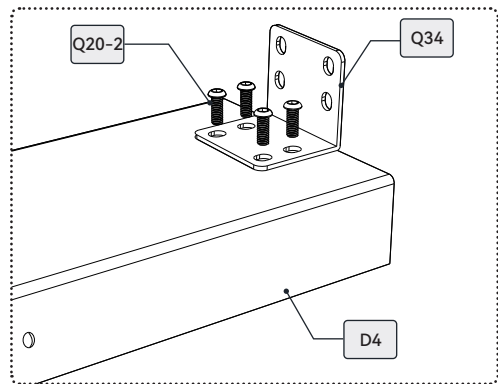
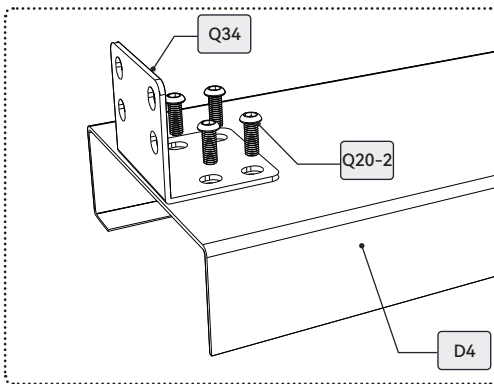
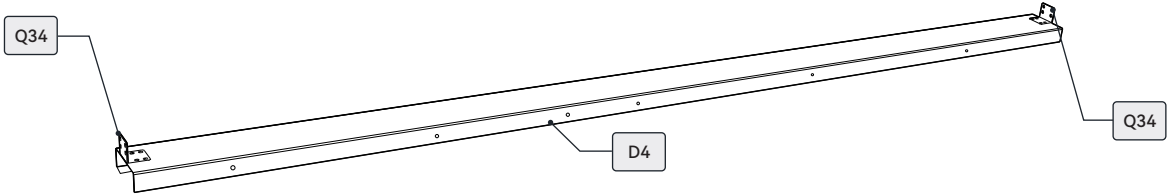



Q20-2			8	Z3		4mm
Q34			2	Z4		4mm



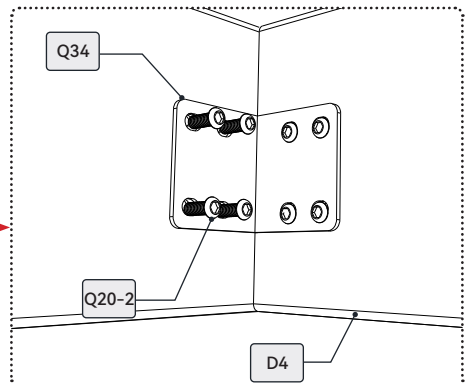
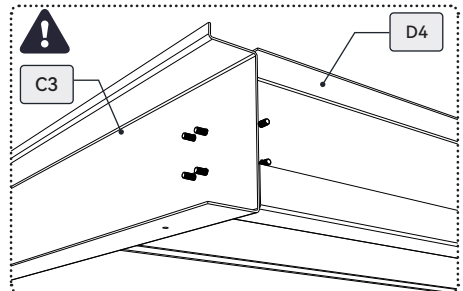
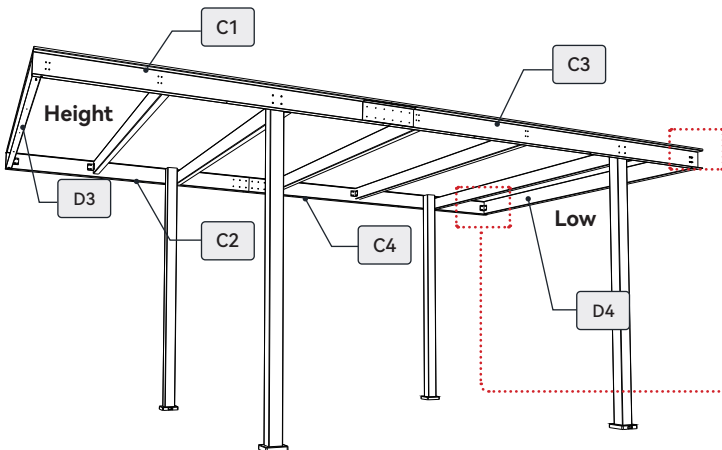

Q20-2			8	Z3		4mm
				Z4		4mm

Mount the D4 sub-beam, with the Q34 beam accessory pre-installed, onto the main beam.



F1		1
----	---	---

Q32-1		8
Q34		8

Z9		8mm
----	--	-----

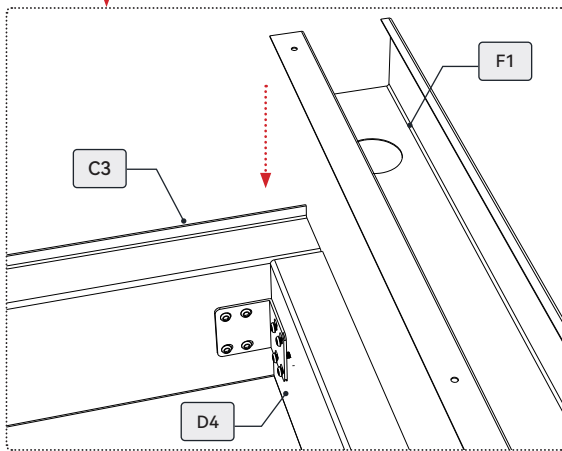
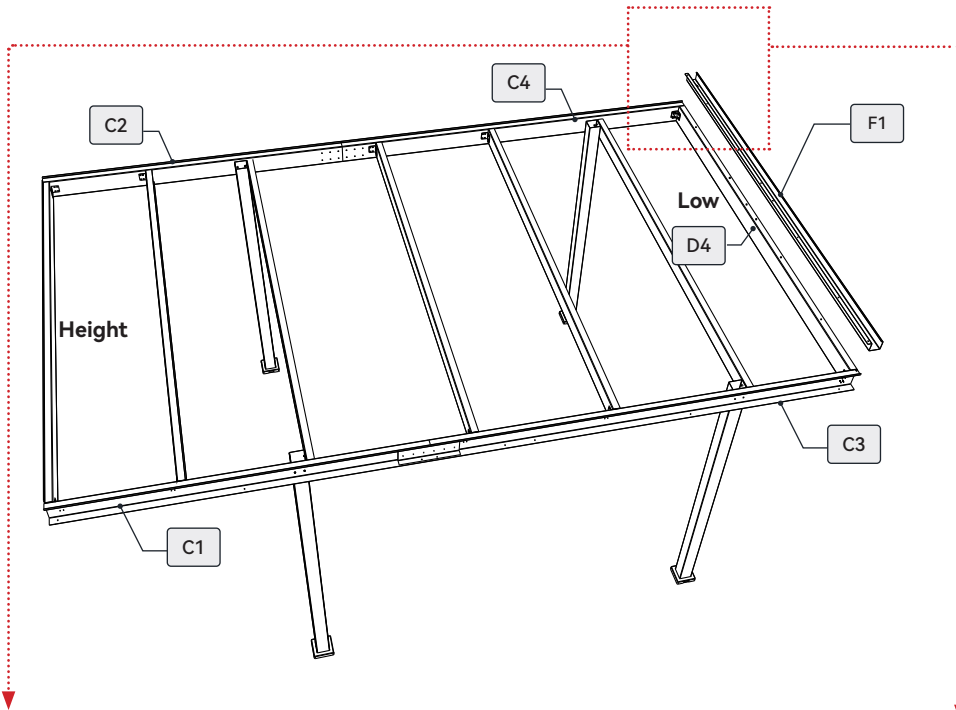

Mount the F1 gutter on the upper side of the D4 beam as shown in the illustration.

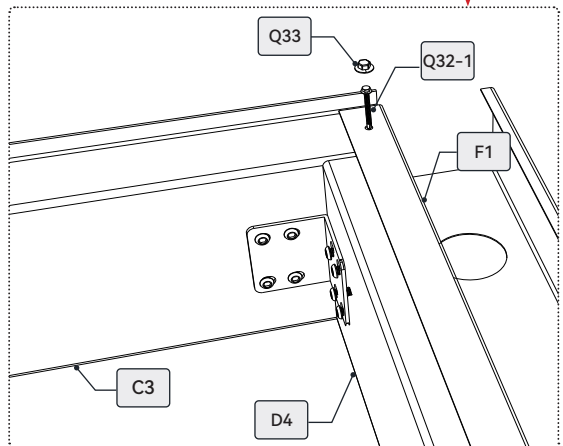

Drive Q32-1 screws into the pre-drilled holes on the gutter and cap them with Q33 covers.

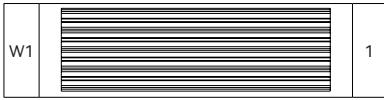

Q32	4.8x45 8mm	2
Q33		2

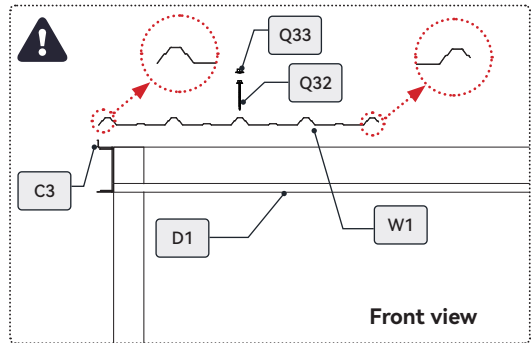
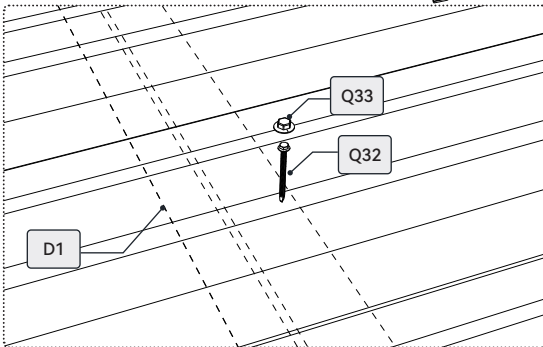
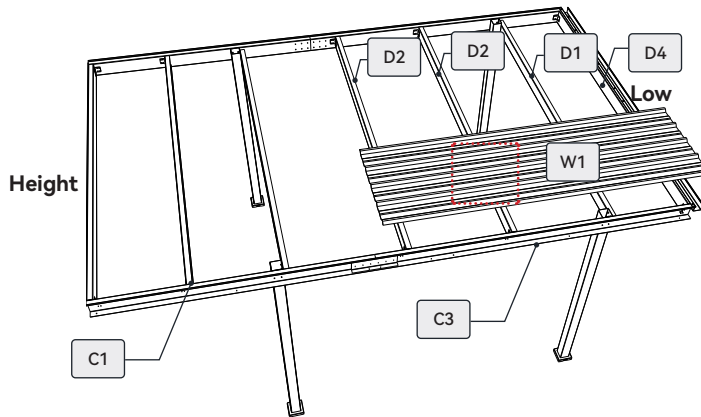
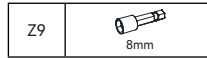

Cover the corrugated metal tile on top of D1, then drive Q32 screws into the marked position and cap them with Q33 covers.

Pay attention to the differences at the ends of the tiles. Place them on both sides in the orientation as shown in the illustration.

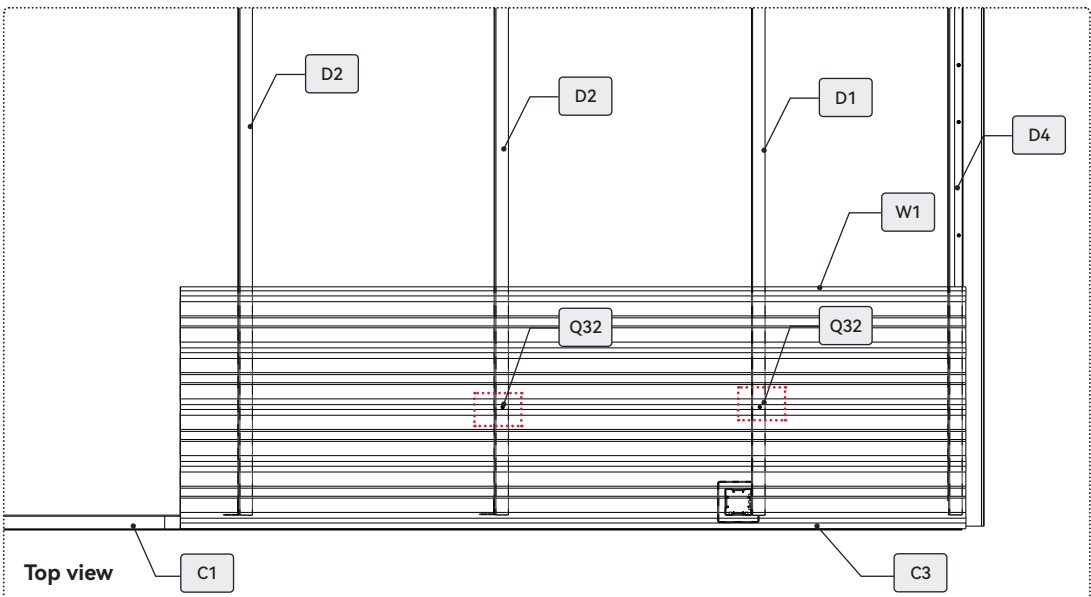

At the W1 tile position within the dotted-line frame shown in the diagram, drive Q32 screws to secure it above the crossbeams D1/D2. Note that no screws should be used at this step for the areas above D3 and C1/C3; these will be fixed with screws only after the frame B1/2/3/4/5 is installed in the final stage to secure the entire structure.

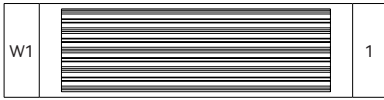

Q32		4
Q33		4

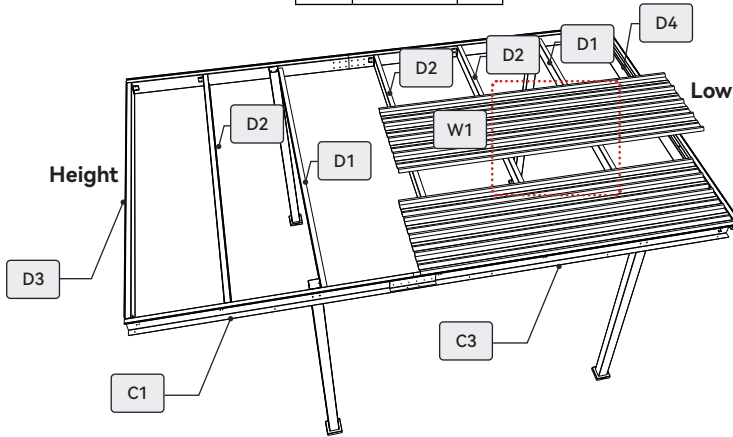
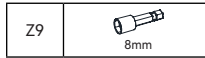

Attention: After installing each corrugated metal tile, immediately secure it with screws at the marked positions. Otherwise, it will be difficult to fix subsequent metal tiles in place.

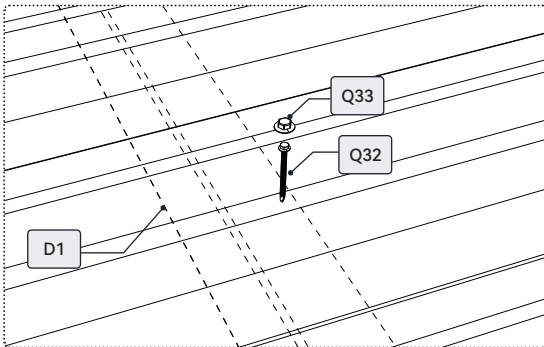

Cover the corrugated metal tile on top of D1, then drive Q32 screws into the marked position and cap them with Q33 covers.

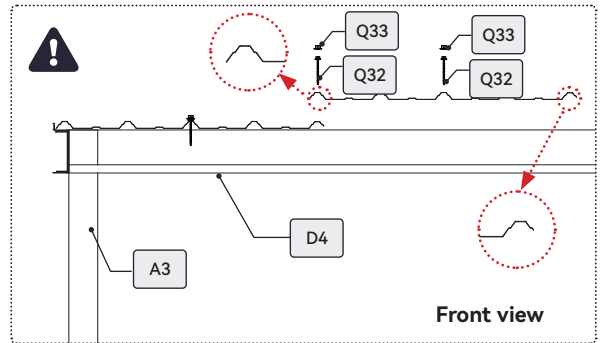

Pay attention to the differences at the ends of the tiles. Place them on both sides in the orientation as shown in the illustration.

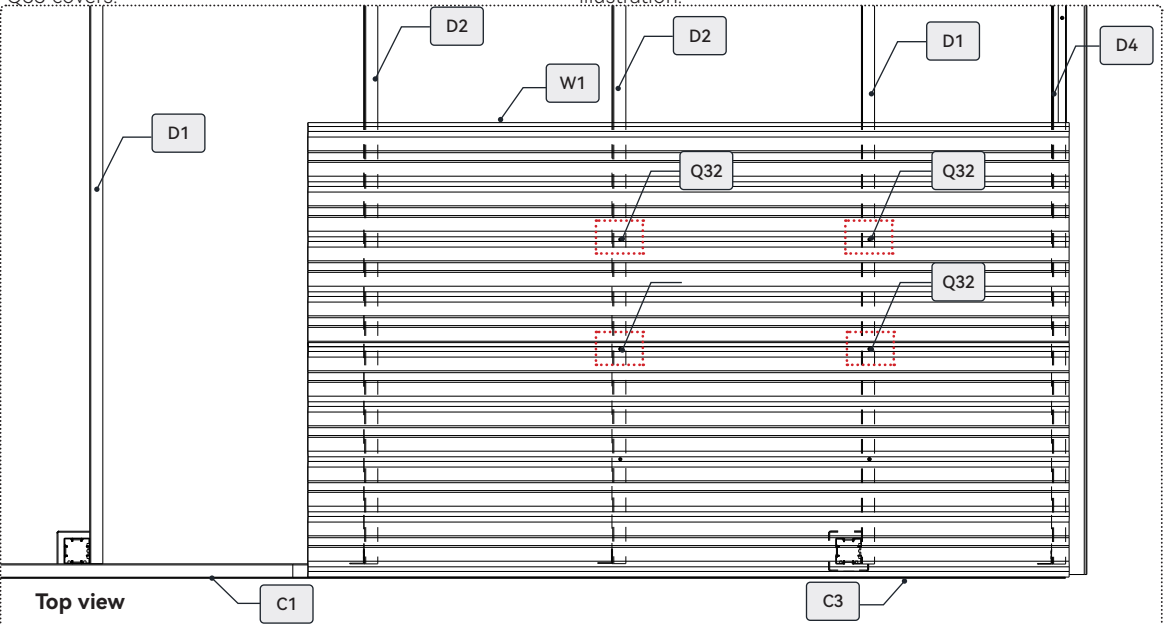

At the W1 tile position within the dotted-line frame shown in the diagram, drive Q32 screws to secure it above the crossbeams D1/D2. Note that no screws should be used at this step for the areas above D4 and C1/C3; these will be fixed with screws only after the frame B1/2/3/4/5 is installed in the final stage to secure the entire structure.

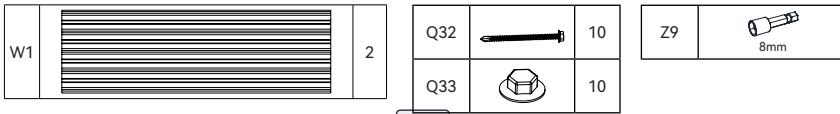

Attention: After installing each corrugated metal tile, immediately secure it with screws at the marked positions. Otherwise, it will be difficult to fix subsequent metal tiles in place.

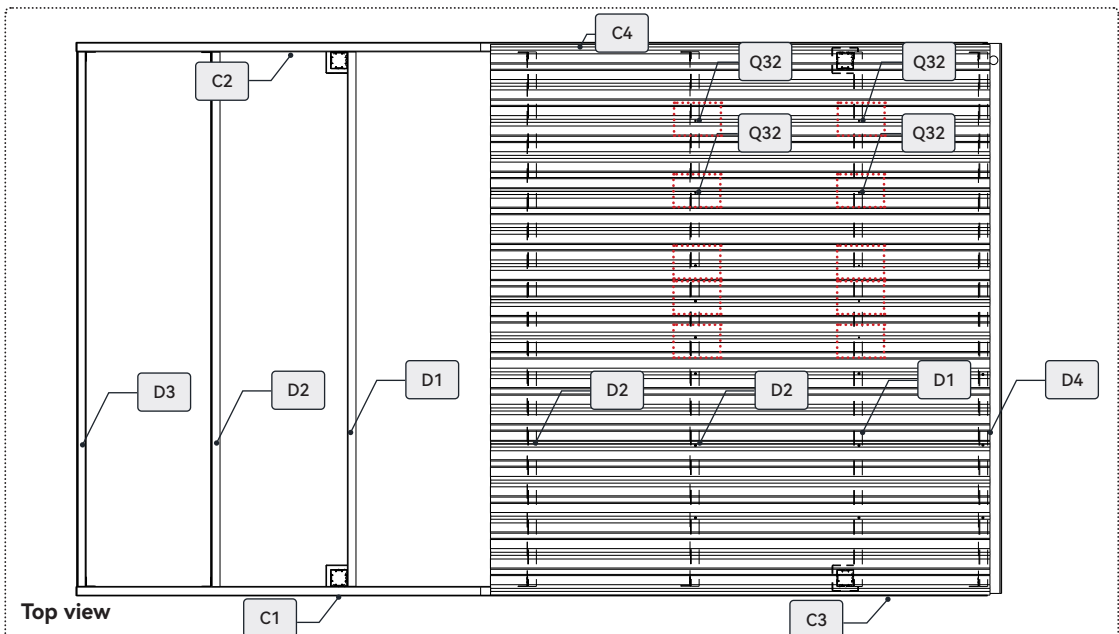
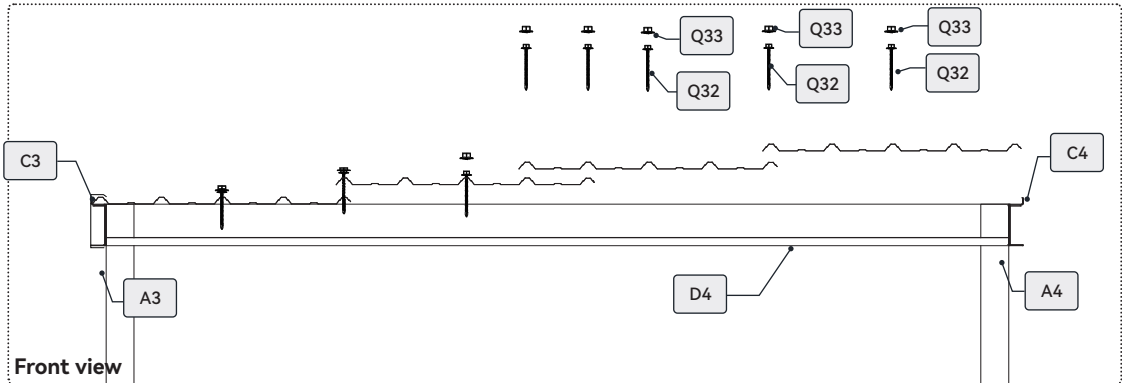
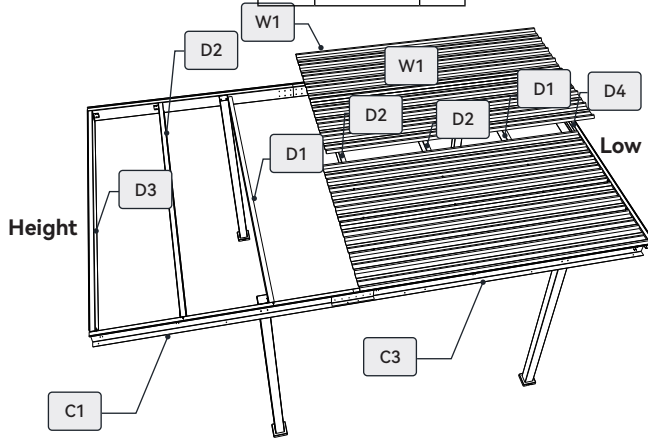

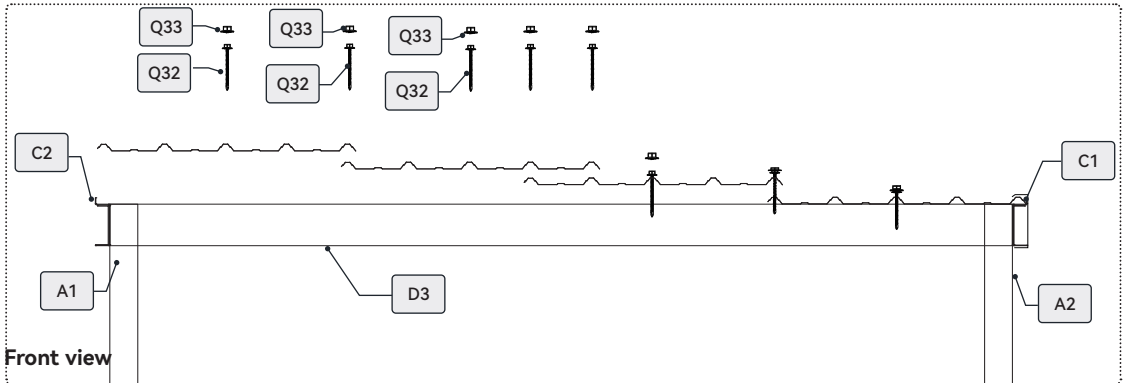
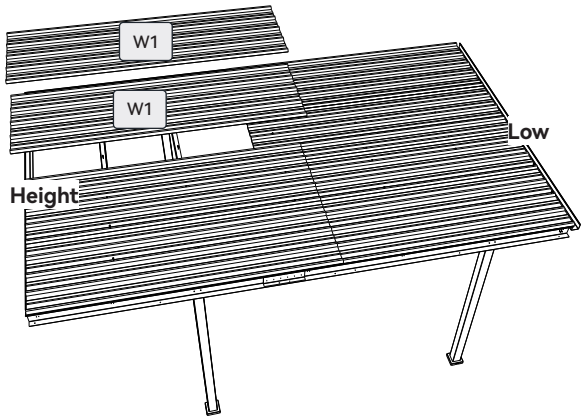
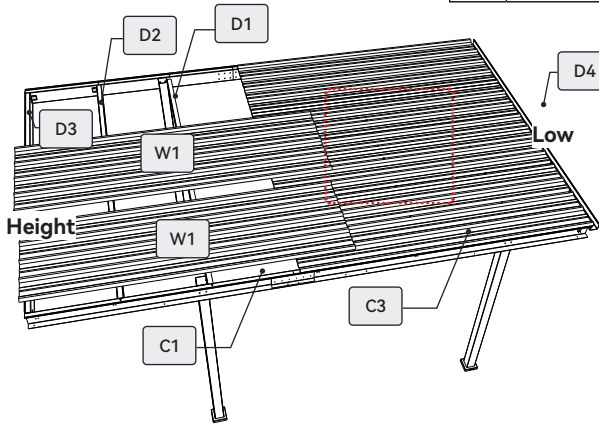
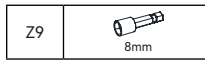
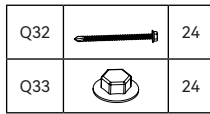

At the W1 tile position within the dotted-line frame shown in the diagram, drive Q32 screws to secure it above the crossbeams D1/D2. Note that no screws should be used at this step for the areas above D4 and C1/C3; these will be fixed with screws only after the frame B1/2/3/4/5 is installed in the final stage to secure the entire structure.



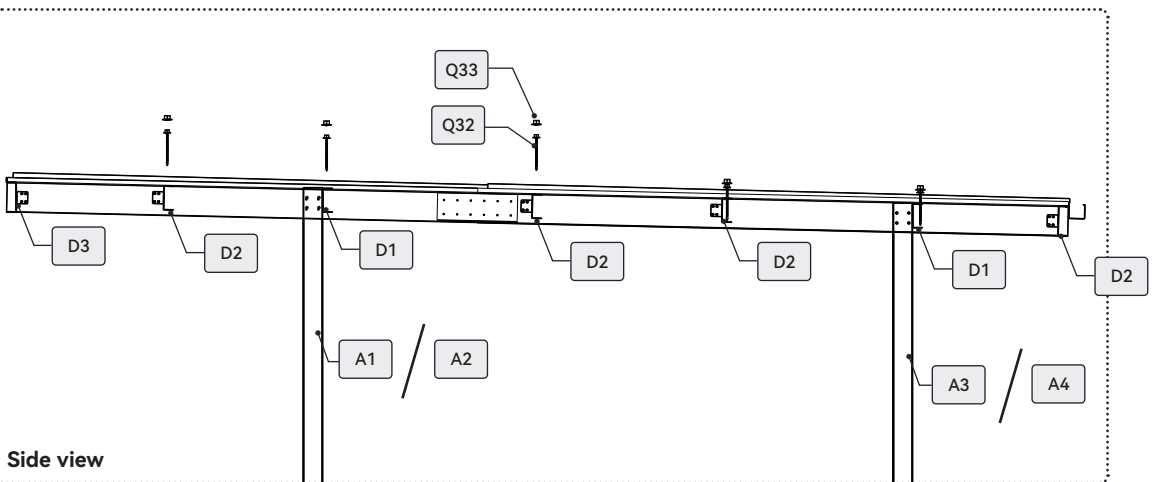

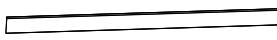

Attention: After installing each corrugated metal tile, immediately secure it with screws at the marked positions. Otherwise, it will be difficult to fix subsequent metal tiles in place.



At the W1 tile position within the dotted-line frame shown in the diagram, drive Q32 screws to secure it above the crossbeams D1/D2. Note that no screws should be used at this step for the areas above D4 and C1/C3; these will be fixed with screws only after the frame B1/2/3/4/5 is installed in the final stage to secure the entire structure.









B2		1
B4		1

Q20-2		6x16	4mm	7
Q32-1				6
Q33				6

Z3		4mm
Z4		4mm

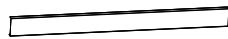
Z9		8mm
----	---	-----

Drive Q20-2 screws into the bottom of B2/B4 to secure the frame to the beam. Drive Q32-1 screws into the top of B2/B4, aligned with the Q32 screws along the same line

B3		1	Q20-2		6x16 4mm	7	Z3		4mm	Z9		8mm
B5		1	Q32-1			6	Z4		4mm			
			Q33			6						

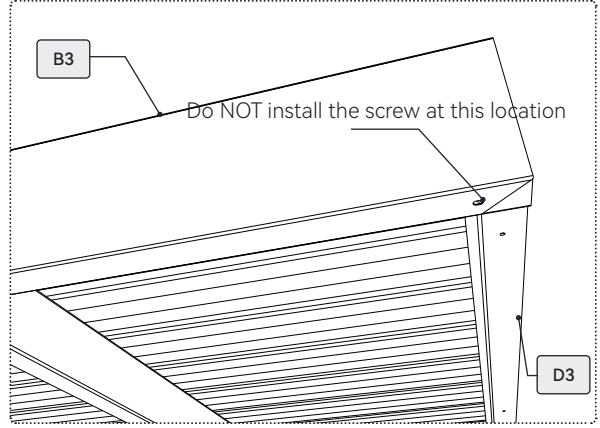
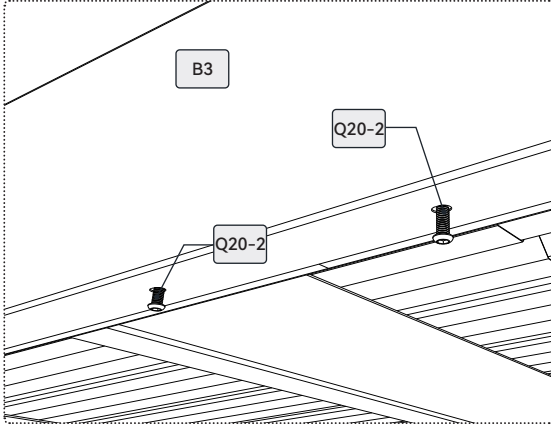
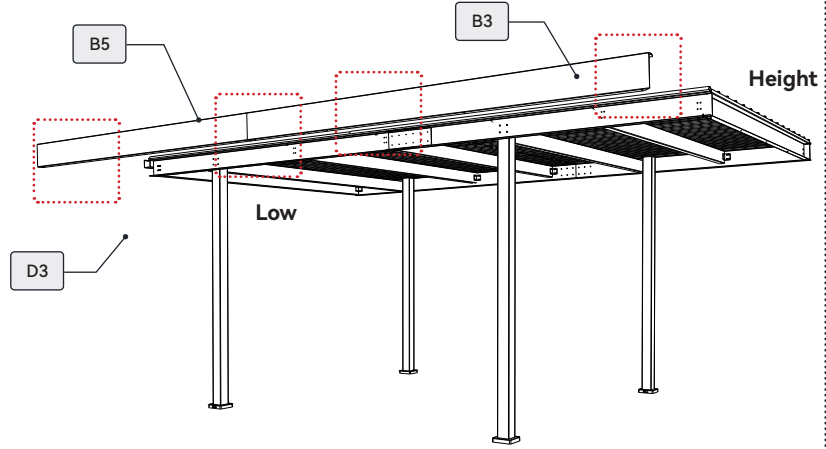
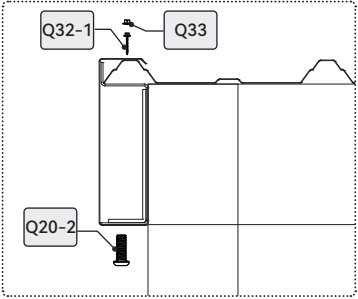
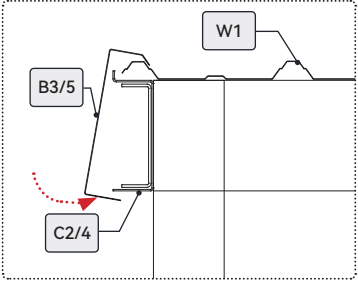

Drive Q20-2 screws into the bottom of B3/B5 to secure the frame to the beam. Drive Q32-1 screws into the top of B2/B4, aligned with the Q32 screws along the same line

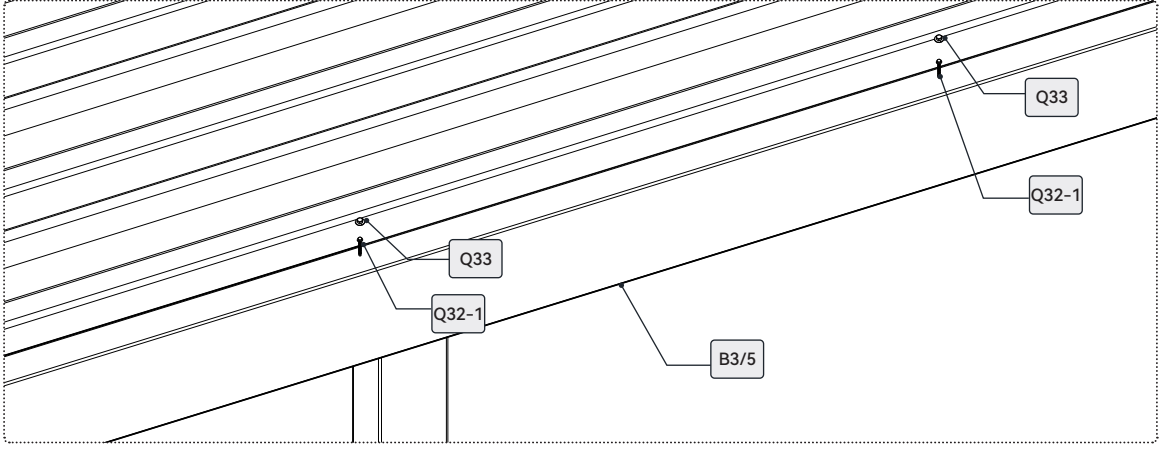

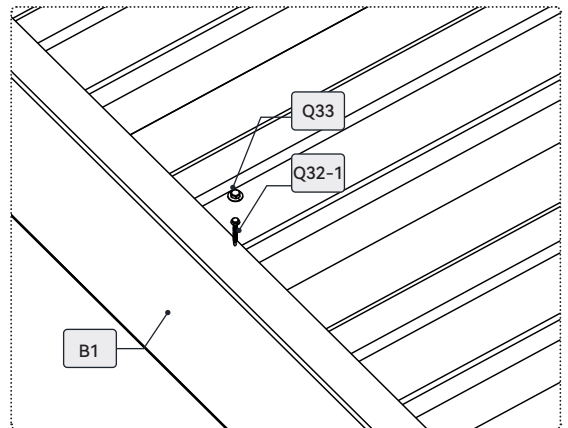
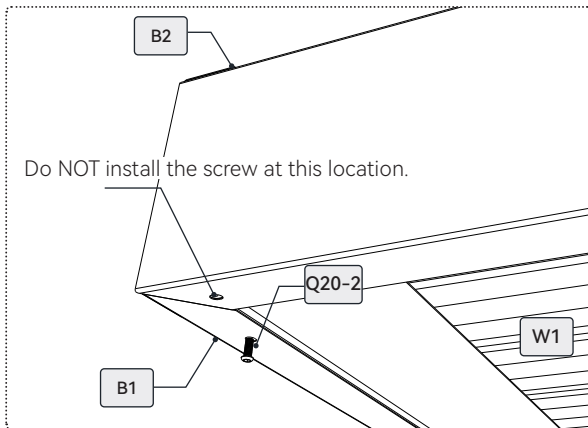
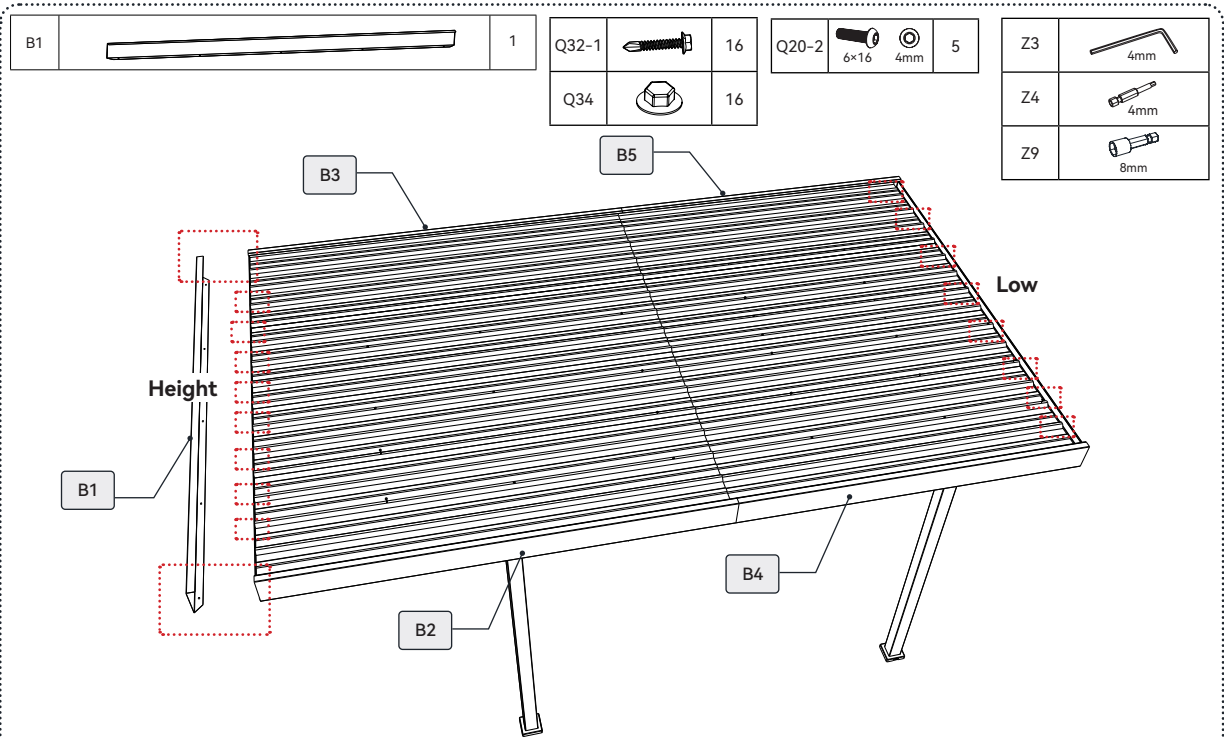

Drive Q32-1 screws into B1 at the positions shown in the diagram, and cap them with Q33 covers.

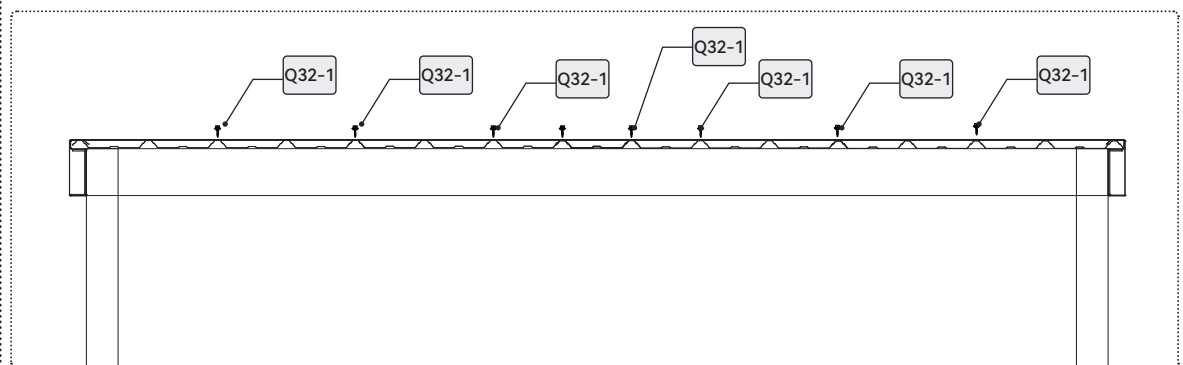

T1		1
----	--	---



T2		1
----	--	---



Q32-1		4
Q34		4

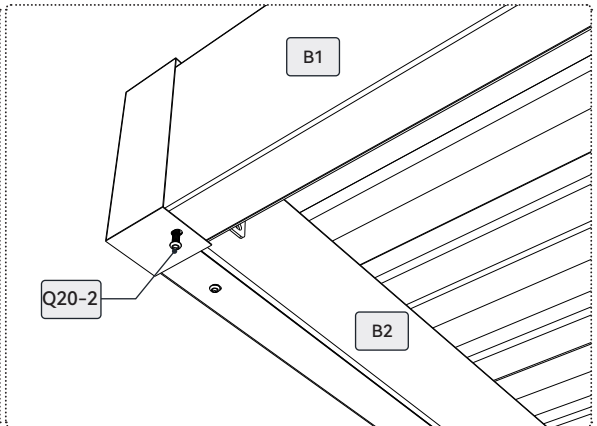
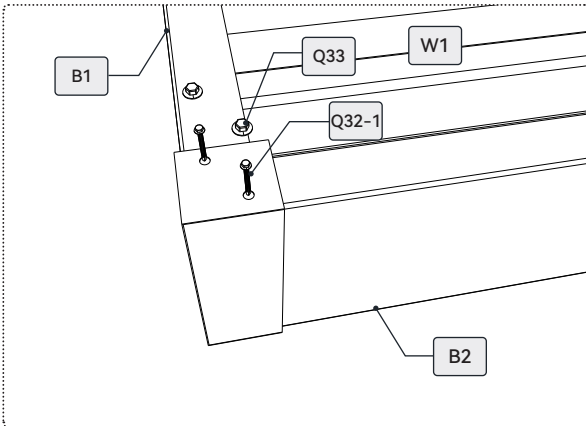
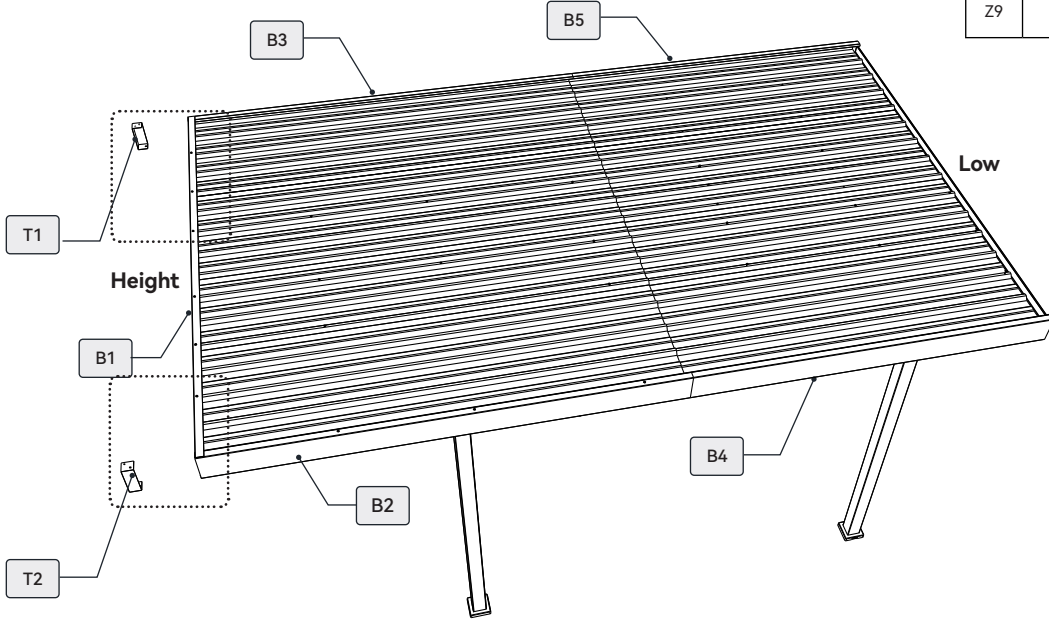

Q20-2		6x16	4mm	2
-------	--	------	-----	---

Z3		4mm
Z4		4mm
Z9		8mm



E1		1
E2		1
E3		1

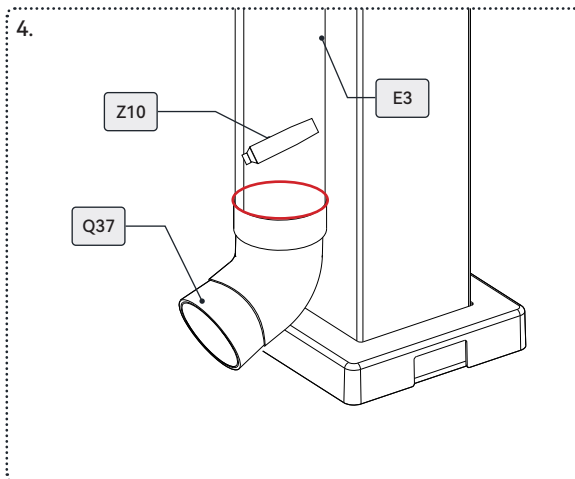
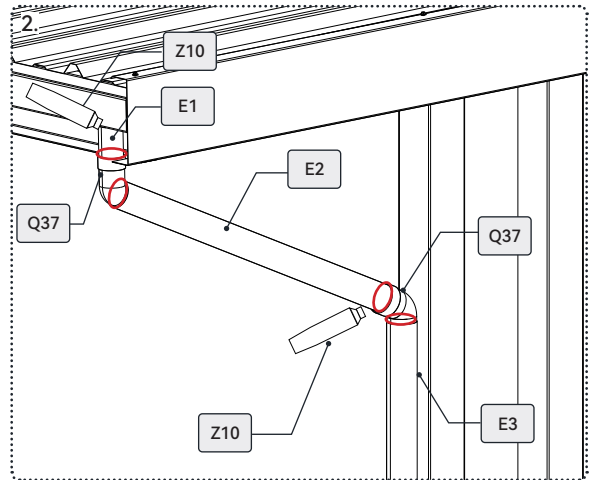
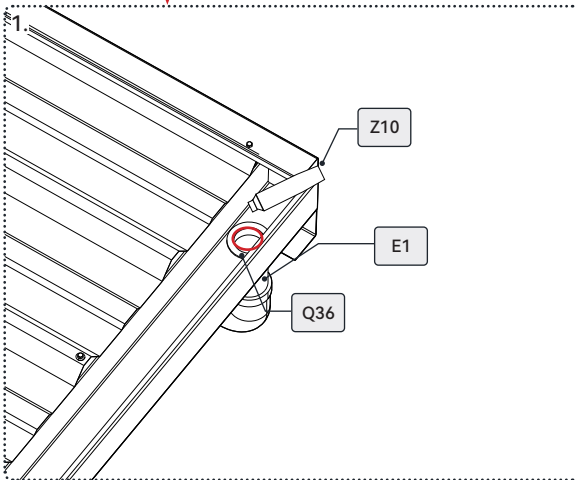
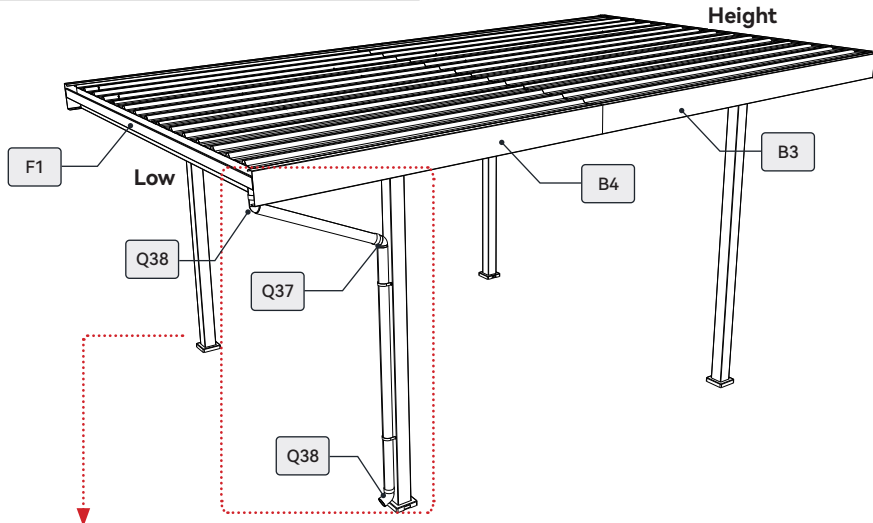

Q36		1
Q37		3

Z9		8mm
Z10		



Attention:

Waterproof sealant must be applied at the water pipe connections.

Q35		2
WO-1		4

Z9		8mm
----	--	-----

