



THERMOLAMINATED
DOORS, PANELS
AND PRODUCTS

DESIGNERFORM

AUSTRALIA **bonlex**

OVERHEAD DOORS,
DRAWERS AND PANELS
SEASPRAY 4095 10MM
Bonlex Classic White Satin

DESIGNER**FORM**

Designerform's THERMOLAMINATED doors and panels offer is inspired by the latest global trends to provide you with the designs, colours and finishes to enhance your individual character and style of your kitchen, the centrepiece of your home.

Our dedicated and highly trained tradespeople proudly produce Designerform THERMOLAMINATED doors and panels using only the best quality materials. All doors and panels are constructed using low emission E0 (E-Zero) Australian made environmentally accredited substrate board. Our stylish doors are profiled, edged and pressed using the highest quality Japanese (Bonlex) PVC foil, Australian made E0 substrate board with a programmed fabrication process utilising the latest German and Italian precision machinery in our state-of-the-art Campbellfield facility.

At Designerform, we provide total flexibility on your choice of THERMOLAMINATED doors and panels. With an extensive product range of colours, profiles and designs available, we can offer you the design solutions and outcomes to your commercial and domestic requirements. We invite you to visit our showroom or our website to view our full range of decors and customized service solutions. Our THERMOLAMINATED doors and panels provide you with peace of mind, offering highly resistant and durable surfaces able to withstand the rigors of the day to day impact that a busy family kitchen, pantry, laundry, wardrobe, entertainment, storage and study area demands.

Designerform designs and manufactures standard and customised profile THERMOLAMINATED doors and panels for internal joinery, motorhomes, commercial applications and specifications including kitchens, butler's pantry, laundry, wardrobes, study, storage and wall panel solutions.

If you have your own unique door style in mind, our in-house Designerform programmers would be happy to create one for you. All THERMOLAMINATED doors are available in routed, single sided, double sided and raw MDF finishes. Doors are produced with standard white backs, however, can be colour matched on both sides upon request. All Designerform THERMOLAMINATED manufactured doors and panels are backed by our 7-year limited manufacturer warranty.

Designerform is an established market leader due to our commitment to quality, service and on time delivery as an Australian made and family owned custom-made solutions provider of THERMOLAMINATED doors and panels.



DOORS

ANGLESEA 4199 6MM

Bonlex White Satin

STYLE **FOUR** // ALL PROFILES NOT AVAILABLE IN GLOSS



VENUS
4030



APOLLO
4060



TORQUAY
4080

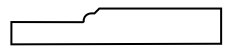

ANGLESEA
4099

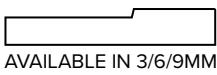

SORRENTO
4150

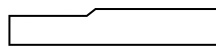

METUNG
4170

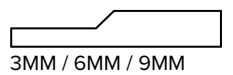

LONSDALE
4177

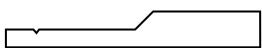

PORTSEA
4187

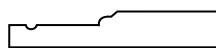

PAYNESVILLE
4196

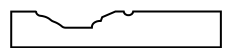



SEASPRAY
4095

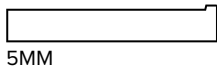

5MM



KALGOORLIE
1984

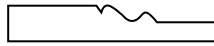

SEASPRAY
4095

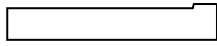

10MM



SEASPRAY
4095

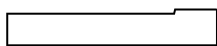

20MM



DOORS
COTTESLOE 1005
Bonlex Clamshell Satin

RAW DOORS



**YEPPON
2150**



**BANGALOW
3172**



**AIREYS
4100**



**ANGLESEA
4099**



JCURVE



**JCURVE
18MM | 21MM**

ONLY AVAILABLE IN
RAW, READY TO PAINT
OR PAINTED.

FLUTES



[1]

[2]

[3]



ROSETTE

ALL DOORS IN
THIS BROCHURE
ARE AVAILABLE IN
DOUBLED SIDED
WHITE FOR PAINT.

PAINT

All doors in this brochure are available in double-sided white supplied for paint or painted by Designerform.

The Dulux colour range is now available in 2 PAC at Designerform. Please inquire for more information. Visit the Dulux website to view the complete colour range.

Advantages of ordering Designerform

2 PAC Kitchen Doors and Panels:

- A single contact turnkey solution provider of finished 2 PAC doors and panels.
- Large selection of Designerform profiles available – <https://designerform.com.au/products/kitchen/door-styles/>
- Select from the full range of DULUX colours and finishes – <https://www.dulux.com.au/colours>.
- Efficient single point of contact with competitive supply timelines.

WHAT IS A 2 PAC KITCHEN?

- A 2 PAC Polyurethane door/ panel is the most common material used for kitchens, robes, vanities, custom joinery and commercial projects.
- With excellent durability there is no limit on colours and available gloss levels from 10% (matt), 25% (satin), 50% (semi-gloss) and 100% (full gloss).
- Low maintenance and easy-to-clean.

Contact your Designerform representative or our office for further assistance.

DOORS AND DRAWERS

ANGLESEA 4199 6MM

2 PAC Dulux Natural White Satin (doors) and Dulux Waltzing Satin (drawers)



COLOUR PALETTE

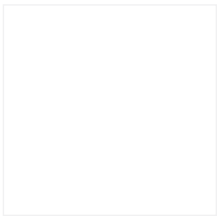

DESIGNER
WHITE BREEZE

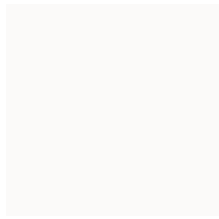

CLASSIC WHITE
BREEZE



SPADA BREEZE



MITILO BREEZE



INK BREEZE

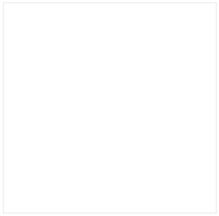

WHITE
SUPERMATT

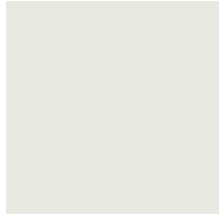

VONGOLE
SUPERMATT



CLAMSHELL
SUPERMATT



PELTRO
SUPERMATT



BAYLEAF
SUPERMATT

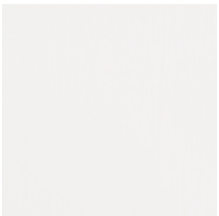

WHITE HUSK



SOOT HUSK



MACEDON OAK



A PROUD AUSTRALIAN
MANUFACTURER FOR OVER
30 YEARS, FAMILY-OWNED
AND OPERATED

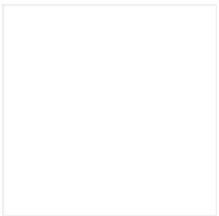

WHITE SATIN

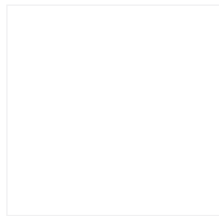

DESIGNER
WHITE SATIN

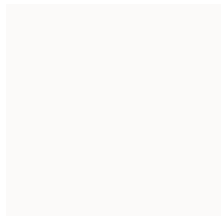

CLASSIC
WHITE SATIN

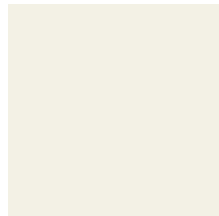

PARCHMENT
SATIN

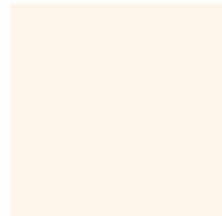

ANTIQUE SATIN

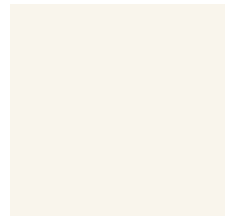

ALABASTER
SATIN



MALIBU SATIN



ROYAL OYSTER
SATIN

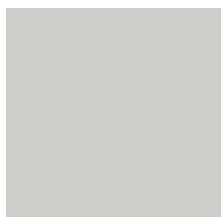

LUNA SATIN

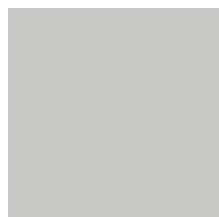

CLAMSHELL
SATIN



SPRUCE SATIN

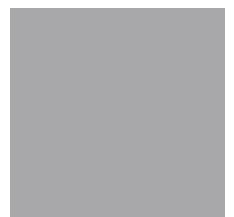

PELTRO SATIN

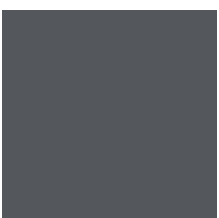

SPADA SATIN



MITILO SATIN

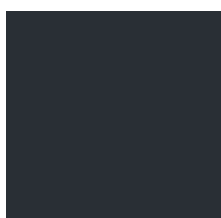

BATTALION
SATIN



INK SATIN



BLACK SATIN

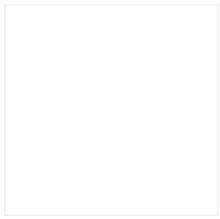

WHITE GLOSS

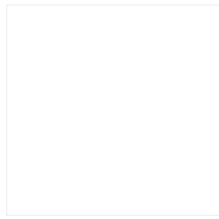

DESIGNER
WHITE GLOSS

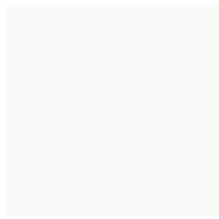

CLASSIC WHITE
GLOSS

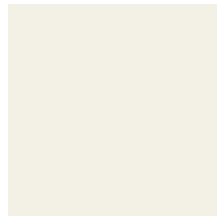

PARCHMENT
GLOSS

*Please note colours are indicative only. Although the utmost care is taken to ensure the colours and patterns shown in this brochure are accurate, variations do occur in print. Please check your chosen colour against a physical sample swatch.

*Black backs available for darker colours. Please note this on your order.

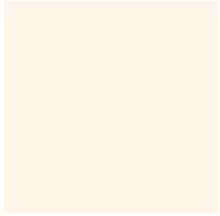

ANTIQUÉ
GLOSS

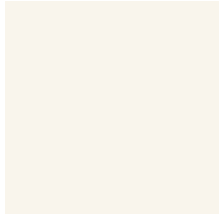

ALABASTER
GLOSS



ROYAL OYSTER
GLOSS

AUSTRALIA **bonlex**[®]

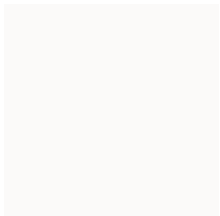

CLASSIC
WHITE LUXE

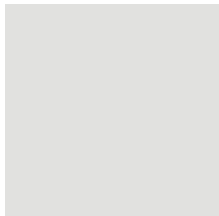

SALTBUSH
LUXE

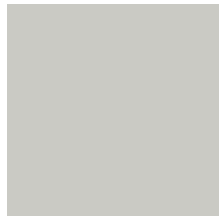

LEMONGRASS
LUXE

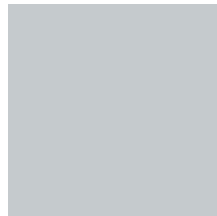

COLOMBO
LUXE



ARTICHOKE
LUXE



KARVOUNO
LUXE



DRAWERS

BONDÍ 3083

Bonlex Parchment Gloss

DOORS

ALBANY 1983 (CUSTOM SPACING)

Bonex Clamshell Supermatt



STYLE **THREE**



BYRON
3011



COOGEE
3012

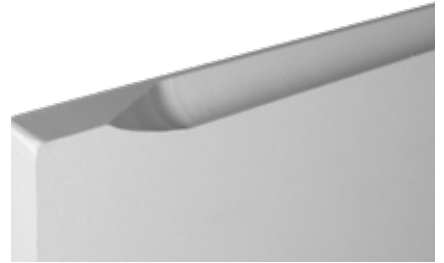
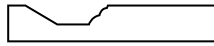

EDEN FINGERPULL
3013



WATSON
3014

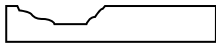

NEWCASTLE
3015

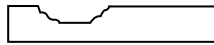

MACQUARIE
3019



BONDI
3083

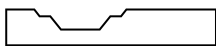

MOLLYMOOK
3116

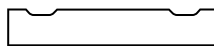

MANLY
3117



STYLE **THREE**



LENNOX
3141

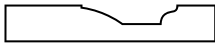

TWEED
3171

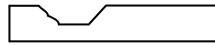

BANGALOW
3172

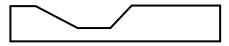

MANNING
3173

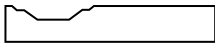

KINGSCLIFF
3174

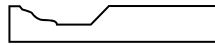

BRUNSWICK
3175

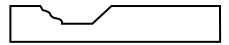

SUFFOLK
3177

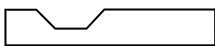

CABARITA
3179

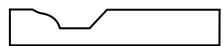



OVERHEAD DOORS
ANGLESEA 4099 6MM
Bonlex White Satin

DRAWERS AND ISLAND BENCH
ANGLESEA 4099 6MM
Bonlex Spruce Satin



DOORS

ALBANY 1983 (CUSTOM SPACING)

Bonlex Clamshell Supermatt

STYLE **THREE**



HASTINGS
3181

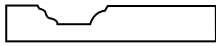

SUSSEX
3182



TERRIGAL
3184

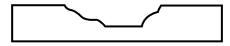

AVOCA
3185

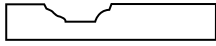

NELSON
3186

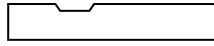

PAMBULA
3187

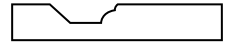

AVALON
3188

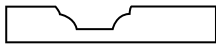

YAMBA
3189

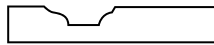



OVERHEAD DOORS

COTTESLOE 1005

Bonlex Classic White Satin

The Johnson – Art Series Hotel Brisbane



STYLE TWO



**EMERALD
2199**

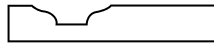

**ISA
2110**

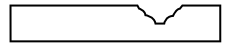

**ROMA
2111**



**TAMBO
2120**

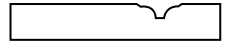

**LONGREACH
2130**

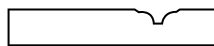

**CLONCURRY
2144**

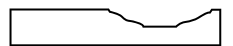

STYLE TWO



YEPPON
2150

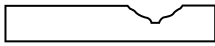

MACKAY
2155

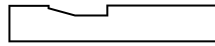

DALBY
2188



KINGAROY
2190

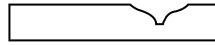

CHINCHILLA
2330



CLERMONT
2410





DOORS

ANGLESEA 4199 6MM

Bonlex Black Satin and White Satin

CUSTOMISED WALL PANELLING

Bonlex Royal Oyster Gloss

Crown Casino Perth – 21 Levels





STYLE TWO



EXMOUTH
1983



ALBANY
1983

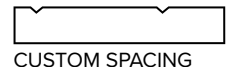

VASSE
1985

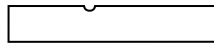

KUNUNURRA
1986

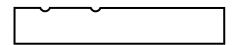

VISIT OUR SHOWROOM
FOR THE LATEST
COLOURS AND TRENDS



AUGUSTA
1990

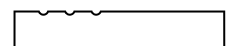

STYLE ONE

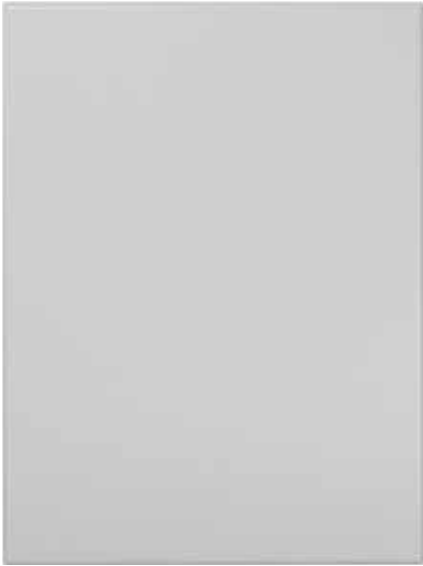

ESPERANCE
1001

EDGE 1 // 6MM



ROTTNEST
1002

EDGE 2



DENMARK
1003

EDGE 3



SUBIACO
1004

EDGE 4



COTTESLOE
1005

EDGE 5



GERALDTON
1009

EDGE 9

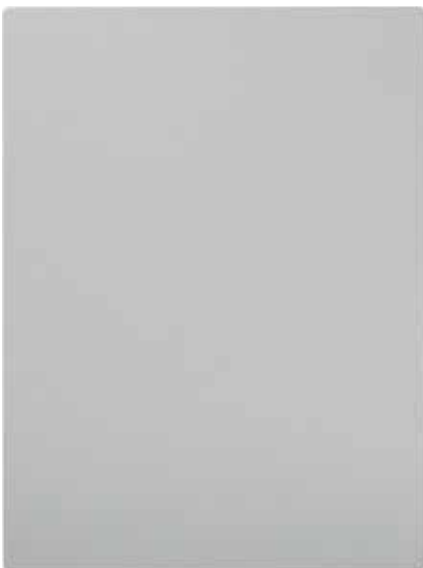

LEEWIN
1010

EDGE 10 // 3MM

AUSTRALIA **bonlex**TM

DESIGNERFORM EXCLUSIVE DISTRIBUTOR
BONLEX PVC FOIL | MADE IN JAPAN.



WALL PANELLING
Bonlex Clamshell Supermatt

DOORS
EXMOUTH 1983 (CUSTOM SPACING)
Bonlex Mitilo Breeze

DOORS

SEASPRAY 4095 20MM

Bonlex Bayleaf Supermatt





DOORS

EXMOUTH 1983 (CUSTOM SPACING)

Bonlex Macedon Oak



CARCASS / FLATPACKS

- DIY – Cabinetry is made to your exact measurements (no set sizing/modular cabinets)
- Range of finishes available
- Flatpack or Assembled
- Hardware supplied
- Soft-closing hardware is standard
- Range of products available include Melamine (Wilsonart, Polytec), Thermolaminated (Bonlex), Acrylic (StyleLite) and 2 PAC (Dulux)

KITCHEN APPLIANCES AND ACCESSORIES BY BLAUPUNKT

- Ovens
- Steam ovens
- Range hoods
- Handles
- Sinks
- Cooktops
- Dishwashers
- Warming drawers

THANK YOU TO ALL OF OUR
INCREDIBLE CLIENTS FOR
PROVIDING THESE BEAUTIFUL
PHOTOGRAPHS TO FEATURE
IN OUR BROCHURE.



A PROUD AUSTRALIAN
MANUFACTURER FOR OVER
30 YEARS, FAMILY-OWNED
AND OPERATED



DOORS AND DRAWERS
ANGLESEA 4099
Bonlex Bayleaf Supermatt





DOORS AND DRAWERS
ANGLESEA 4199 6MM
Bonlex Grigio Satin



ACCESSORIES

DOOR EDGE PROFILES



RANGEHOODS

HEAT DEFLECTORS, OVENS AND DISHWASHERS

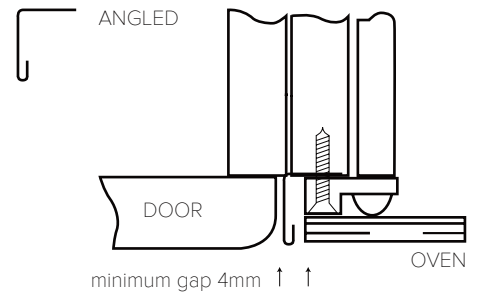
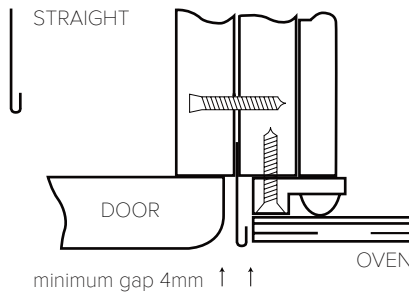

Exposure to high heat over long periods of time may cause damage to THERMOLAMINATED doors and panels.

When installing appliances we recommend that the appliance manufacturer's installation specifications and the Australian Standards AS/NZS 4386.1 are adhered to. Where possible the appliances should be of a ducted exhaust configuration. Concealed rangehoods with THERMOLAMINATED doors and panels will void warranty.

Stainless steel heat deflectors are available from Designerform and are essential for use where heat is likely to come in contact with THERMOLAMINATED doors and panels for example dishwashers, ovens and microwaves. Warranty will be void if heat deflectors are not used.

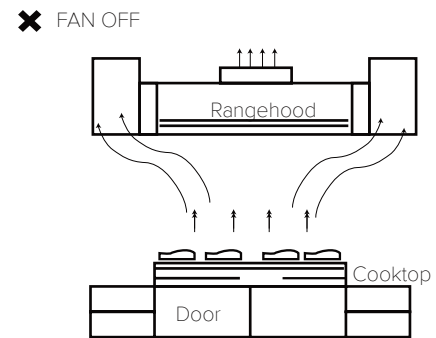
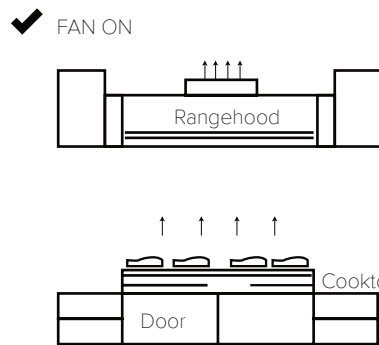

✓ OVEN WITH DUCTED EXHAUST

✗ OVEN WITH FRONT PANEL EXHAUST

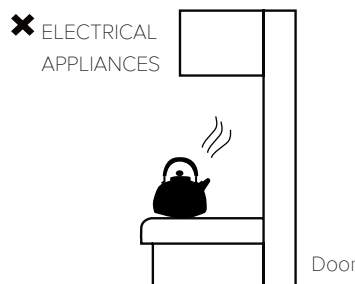
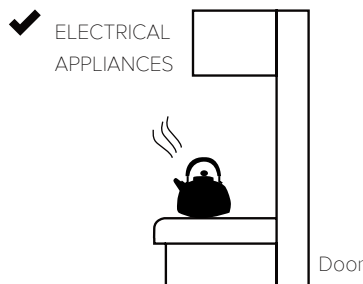
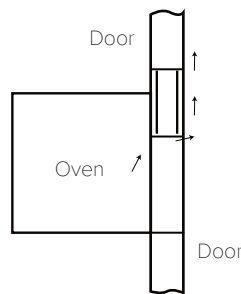
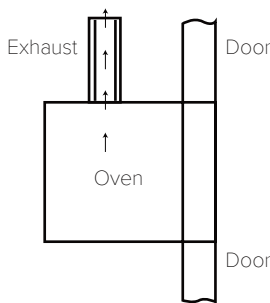

PLEASE NOTE

It is not recommended to use undermount or concealed rangehoods with thermolaminated doors and panels as this will void warranty.

OVERHEAD DOORS

SEASPRAY 4095 10MM

Bonlex Classic White Satin



ACCESSORIES

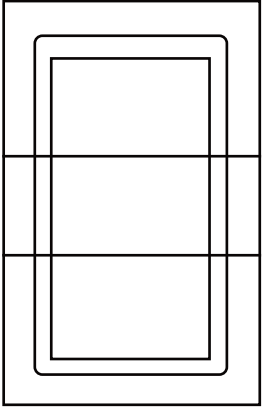

DRAW BANK

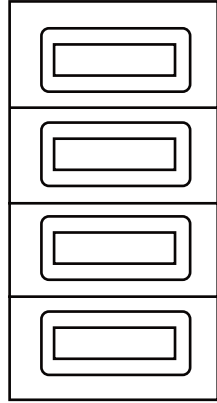

INDIVIDUAL DRAWERS
NOTE: MAY NOT BE SUITABLE FOR ALL PROFILES.

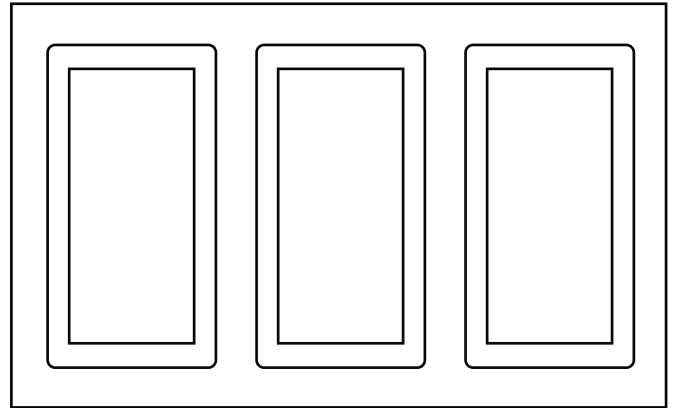

MULTI PANEL
NOTE: OVER 1200M WIDE IS NOT AVAIABLE IN VERTICAL WOOD GRAIN

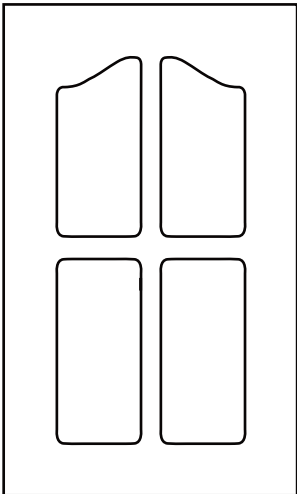

ARCHED COLONIAL FRAME

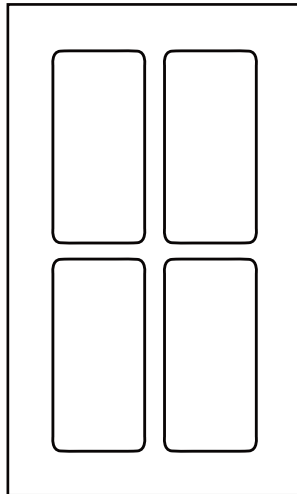

SQUARE COLONIAL FRAME

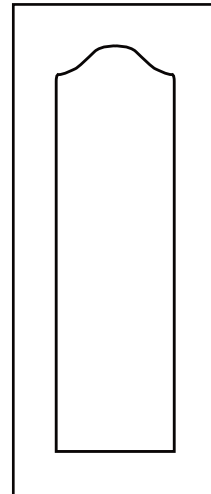

ARCHED FRAME

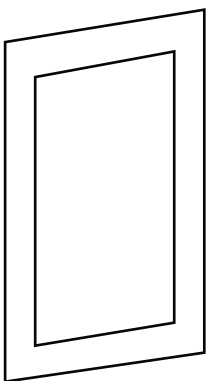

RAW MFD DOORS ARE AVAILABLE IN ALL DESIGNS.



CAPPING MOULDS
NOTE: AVAILABLE IN 3050mm LENGTHS

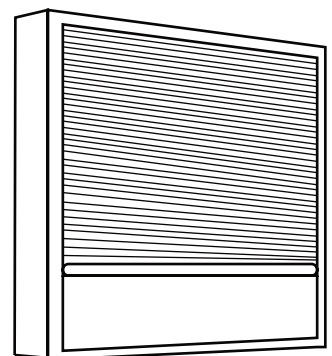

ROLLER SHUTTERS

ACCESSORIES

length

RETURN WRAP PANELS

(A) RP18mm 1 side

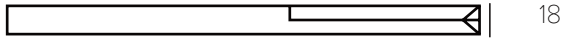

(B) RP18mm 2 sides

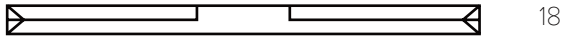

(C) RP36mm 1 sides

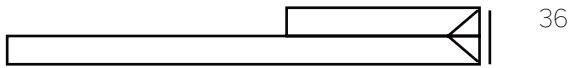

(D) RP36mm 2 sides

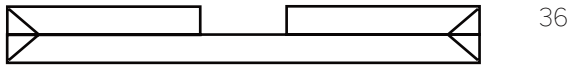

(E) RP36mm + RP18mm

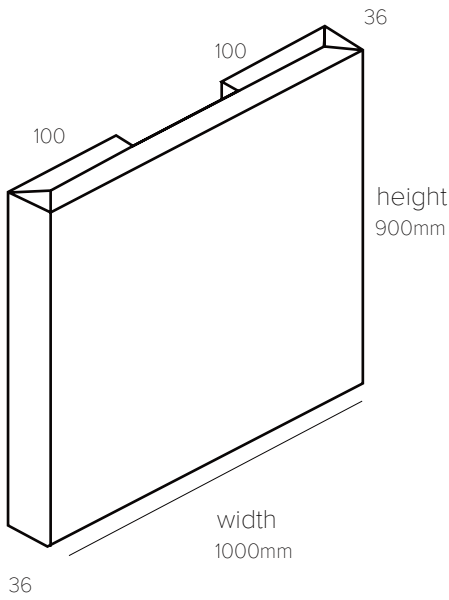
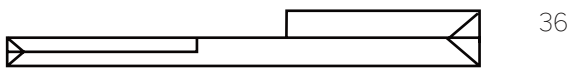

* Exceptions include Square Outer Edge only. (Door profile)

PANEL IS CHARGED AS 1272X900
+ 2X SURCHARGES.

RETURN WRAP SURCHARGE

RECESSED RAILS

L-Shaped Rail
60 x 18
Or
60 x 25

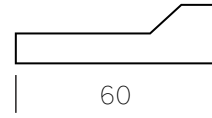

U-Shaped Rail
60 x 18
Or
60 x 25

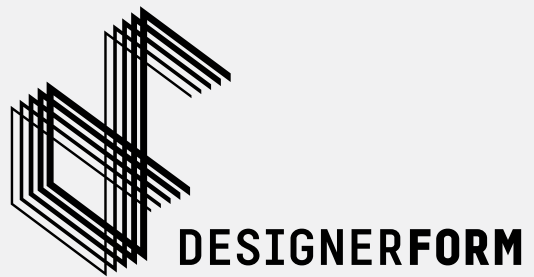
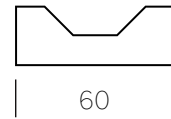

ACCESSORIES

ROLLER SHUTTERS

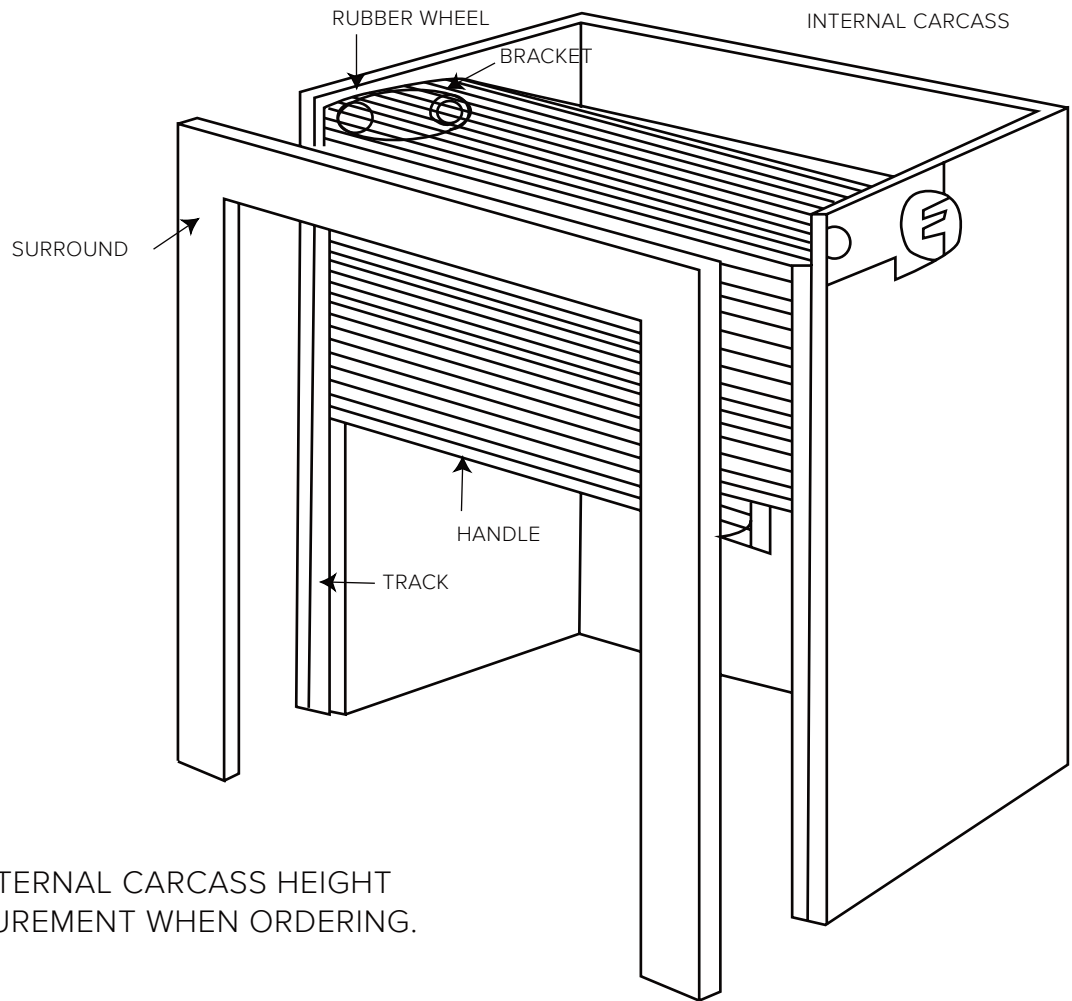

PLEASE SUPPLY INTERNAL CARCASS HEIGHT AND WIDTH MEASUREMENT WHEN ORDERING.

Cut Outs

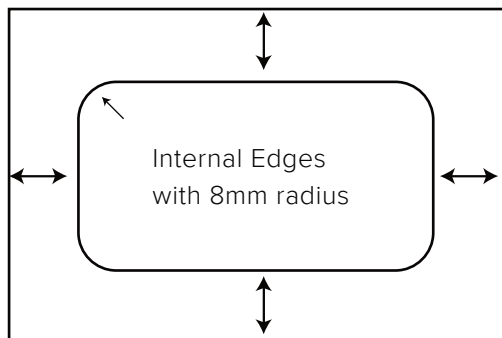

PLEASE SUPPLY BOARDER SIZES.
NOTE BORDERS NOT TO BE SMALLER THAN 20mm

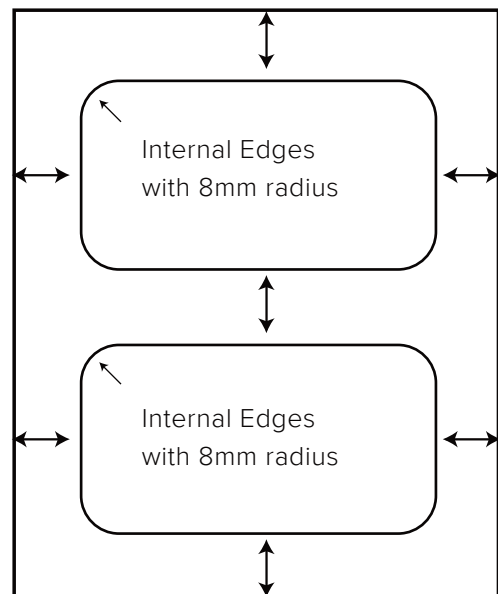



DRAWERS

ALBANY 1983 (CUSTOM SPACING)

Bonlex Clamshell Supermatt

DRAWERS

ALBANY 1983 (CUSTOM SPACING)

Bonlex Mitilo Satin



DESIGNERFORM

19 COOPER STREET, CAMPBELLFIELD
MELBOURNE VIC 3061, AUSTRALIA

PHONE – (03) 9303 7224

EMAIL – ENQUIRIES@DESIGNERFORM.COM.AU

ORDERS – DOORS@DESIGNERFORM.COM.AU

DESIGNERFORM.COM.AU



A PROUD AUSTRALIAN
MANUFACTURER FOR OVER
30 YEARS, FAMILY-OWNED
AND OPERATED

AUSTRALIA **bonlex**[®]