

Muscle Groups Focus

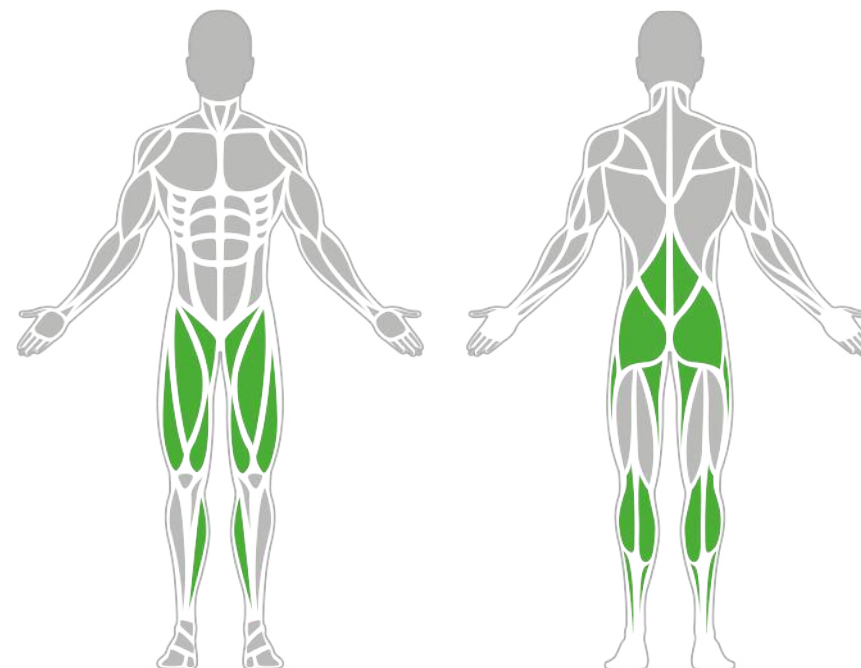

Weighted Squat Machine

The BESTRONG Weighted Squat Machine is an excellent choice for strengthening the lower body, particularly the thigh and gluteus muscles. With adjustable resistance ranging from 20 kg to 85 kg, users can find the right level of difficulty for their needs. The machine is simple, efficient, and safe to use, making it ideal for all fitness levels.

Attributes

Product code	1-1-323
Certificate	EN 16630
Age group	14 + years
Capacity	1 person
Max. weight load	130 kg
Type	Weighted
Difficulty level	Adjustable

Side View

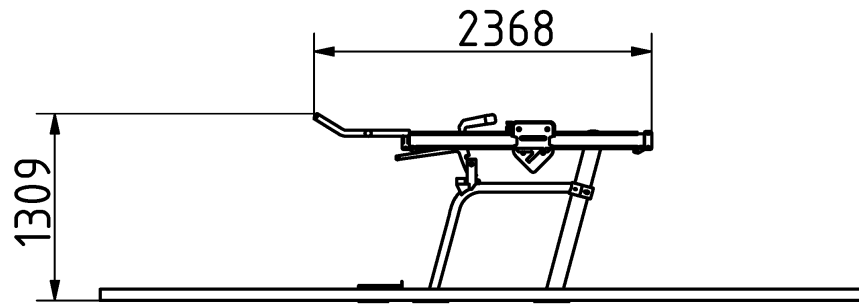

Plan View

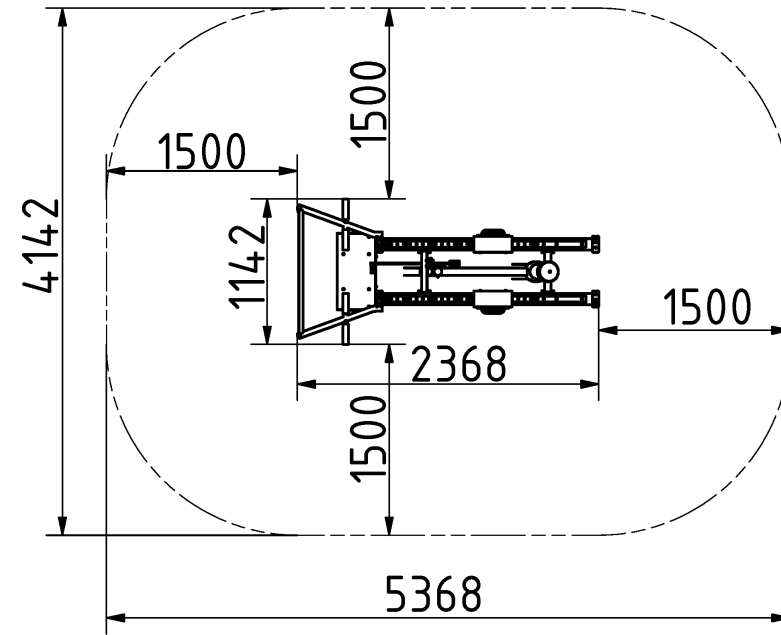

Installation information

Number of installers (concrete)	At least 2 people
Total installation time (concrete)	80-140 min.
Number of installers (equipment)	At least 2 people
Total installation time (equipment)	60 min.
Excavation volume	0.81 m ³
Concrete volume	0.6 m ³
Size of the base structure	1.5 x 0.5 x 0.8 m
Anchoring options	Surface mounted
In combined structures, the volume of concrete required varies.	

Technical specification

Safety surface area	Around 1,5 m radius
Net weight	215 kg
Material	S235,S355,KO33,HDPE
Critic fall height	-
Color options	● ● ● ● ● ●
For more color options, discuss with your sales representative.	

Warranty

Structure	25-15 years
Steel	5-10 years
Paint	2 years
Plastic	5-10 years
Rubber	1-3 years
Moving parts	2 years
Detailed information in the warranty document	

Material specification

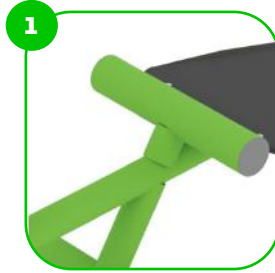
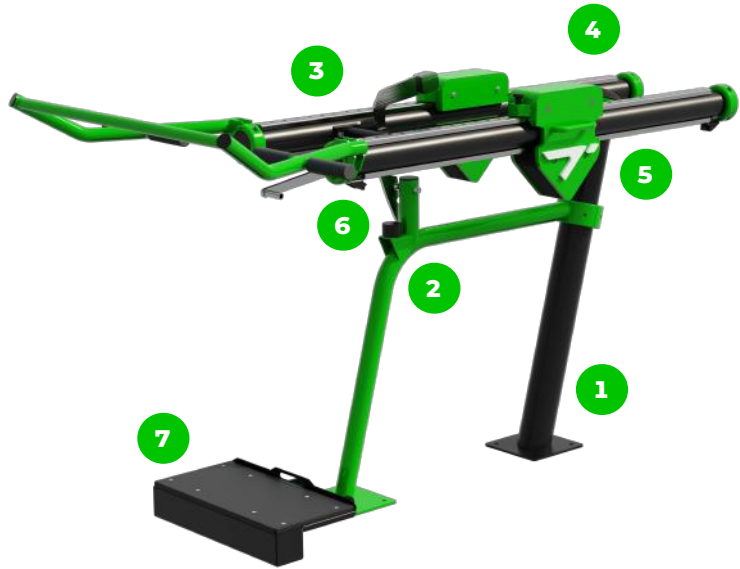

The element is made of high quality S235 steel, which has been cleaned via sandblasting. A corrosion resistant powder coating finish is then applied. Also available with galvanized surface for even greater protection and longevity!



The bumpers of the devices are made of durable rubber material.

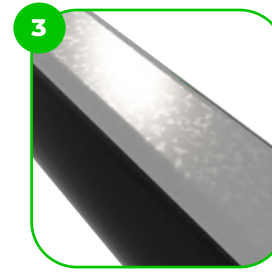

The sliding weight rail is made of high-quality stainless steel, which guarantees the product's long-term durability and resistance to weathering.

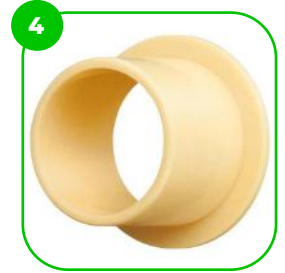

The device is fitted with composite bearings that are weather-resistant. The bearing does not require regular maintenance.



The device is equipped with two 50 kg weights, which allow you to perform workouts of varying intensity.



At the end of the arms, the handle is rubber-coated for a more comfortable and secure grip.



The top surface of the device is covered with the highest quality non-slip HDPE.

BESTRONG

[bestrongworld](#) [bestrongworld](#) [global.bestrong.com](#) [info@bestrong.com](#)

