

iHome

VAC SV2

CORDLESS MULTI-USE
RECHARGEABLE VACUUM



For support content and the latest digital copy of this manual, scan the QR code above or visit ihomeclean.com

Owner's Guide

Model iHSV2



For household use only.

READ ALL INSTRUCTIONS BEFORE USING THIS APPLIANCE. Failure to follow the warnings and instructions may result in electric shock, fire and/or serious injury.

WARNING - To reduce the risk of fire, electric shock, or injury:

- 1: For INDOOR use ONLY. Do not use the appliance in outdoor or industrial environments. Do not use the appliance on wet surfaces or surfaces with standing water.
- 2: Do not allow to be used as a toy. Close attention is necessary when used by or near children, pets or plants.
- 3: The appliance is not to be used by persons (including children) with reduced physical, sensory or mental capabilities, or lack of experience and knowledge, unless they have been given supervision or instruction.
- 4: Do not use with a damaged cord or plug. If appliance has been dropped, damaged, left outdoors or is not working as it should, contact customer service center.
- 5: Do not handle charger, including charger plug, and charger terminals with wet hands.
- 6: Do not block openings. Stop use if openings become blocked. Clean and remove any blocked objects according to the enclosed manual instructions.
- 7: Keep hair, loose clothing, fingers, and all parts of your body away from openings and moving parts.
- 8: Do not use to pick up flammable or combustible liquids, such as gasoline, or use in areas where they may be present.
- 9: Do not pick up anything that is burning or smoking, such as cigarettes, matches, or hot ashes.
- 10: Ensure the switch is in the off position before charging, picking up or carrying the appliance. Carrying the appliance with your finger on the switch or powering on the appliance with the switch on may cause accidents.
- 11: For the purposes of recharging the battery, only use the detachable power adapter provided with this appliance.
- 12: Under improper usage, liquid may be ejected from the battery; avoid contact. If contact accidentally occurs, flush with water. If liquid comes into eye contact, seek medical help. Liquid ejected from the battery may cause irritation or burns.
- 13: Do not use the appliance that is damaged or modified. Damaged or modified batteries may exhibit unpredictable behavior resulting in fire, explosion or risk of injury.
- 14: Do not expose the appliance to fire or excessive heat. Exposure to fire or temperatures above 250°F (121°C) may cause an explosion.
- 15: Only charge, store or use the appliance in a dry indoor area where the temperature is higher than 39.2°F (4°C) but lower than 104°F (40°C). The charger is for indoor use only. Charging improperly or at temperatures outside of the specified range may damage the battery and increase the risk of fire.
- 16: Do not use appliance unless all filters are in place.
- 17: Have servicing performed by a qualified repair person using only identical replacement parts provided by the manufacturer. This will ensure that the safety of the product is maintained.
- 18: Do not modify or attempt to repair the appliance or the battery pack except as indicated in the instructions for use and care.
- 19: Always turn off this appliance before connecting or disconnecting the motorized nozzles and attachments.

FCC Information

- 1: This device complies with Part 15 of the FCC Rules. Operation is subject to the following two conditions: (1) This device may not cause harmful interference, and (2) This device must accept any interference received, including interference that may cause undesired operation.
- 2: Changes or modifications not expressly approved by the party responsible for compliance could void the user's authority to operate the equipment.

NOTE: This equipment has been tested and found to comply with the limits for a Class B digital device, pursuant to Part 15 of the FCC Rules. These limits are designed to provide reasonable protection against harmful interference in a residential installation. This equipment generates uses and can radiate radio frequency energy and, if not installed and used in accordance with the instructions, may cause harmful interference to radio communications. However, there is no guarantee that interference will not occur in a particular installation. If this equipment does cause harmful interference to radio or television reception, which can be determined by turning the equipment off and on, the user is encouraged to try to correct the interference by one or more of the following measures: Reorient or relocate the receiving antenna. Increase the separation between the equipment and receiver.

Connect the equipment into an outlet on a circuit different from that to which the receiver is connected. Consult the dealer or an experienced radio/TV technician for help.

- 1: Rechargeable battery
- 2: Digital screen
- 3: HEPA filter assembly
- 4: Trigger lock
- 5: Trigger
- 6: Dust canister release
- 7: Dust canister
- 8: Dust canister cover latch
- 9: Tube release
- 10: Metal tube
- 11: Suction mode selector
- 12: Full-size power brush
- 13: Crevice tool
- 14: Nozzle (for crevice tool)
- 15: Brush (for crevice tool)
- 16: Charging wall mount (3 parts)
- 17: Mini power brush
- 18: Power adapter

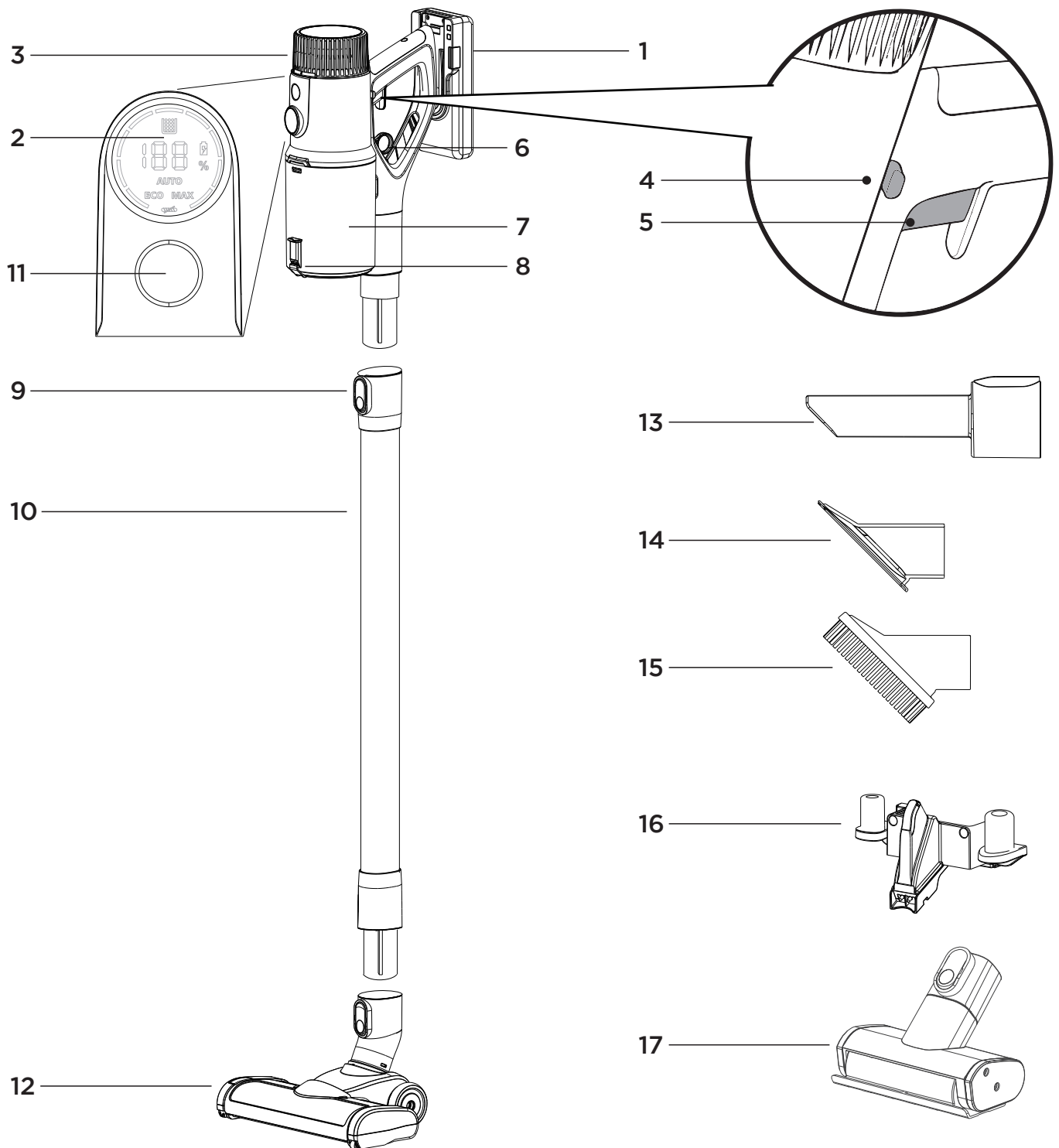

Vacuum assembly

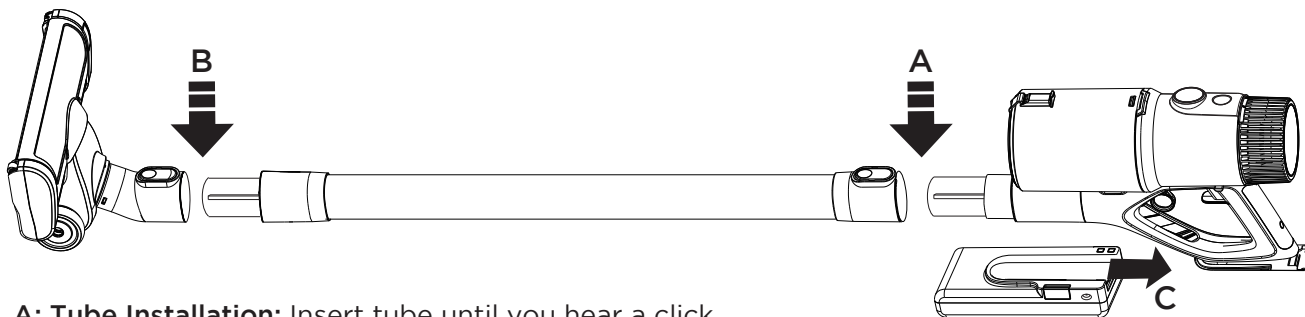

A: Tube Installation: Insert tube until you hear a click.

B: Brush Installation: Insert brush until you hear a click.

C: Battery Installation: Align the battery rails with the track on vacuum and slide in place until you hear a click.

Battery charging

- Plug the power adapter into a functioning wall outlet.
- Before first use the battery may require up to 4 hours to fully charge.
- While charging, vacuum enters standby mode. Remove from charging to operate.

Charging without Wall Mount

Connect the plug directly into the jack on the side of the battery.

Note: Charging percentage will show on digital display.

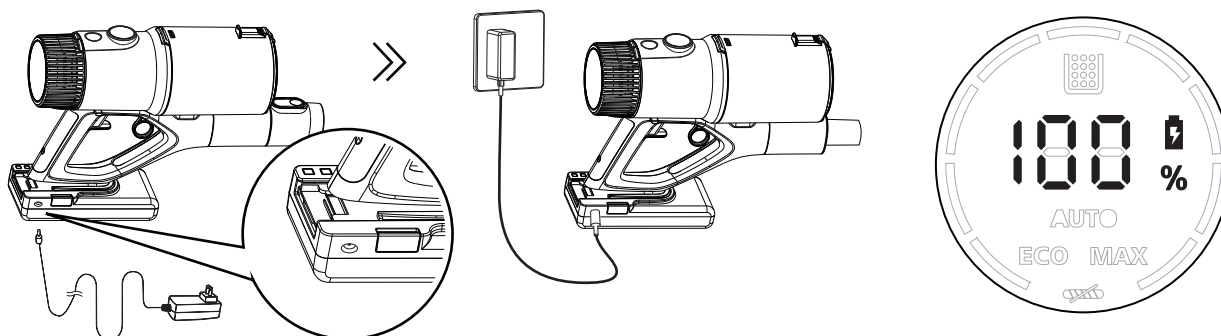

Charging with Wall Mount (For wall mount installation, see next page)

- Connect the plug directly into the bottom of the wall mount.
- Place the vacuum onto the charge mount as seen below.
- Display will turn on when the charge contacts are properly seated.

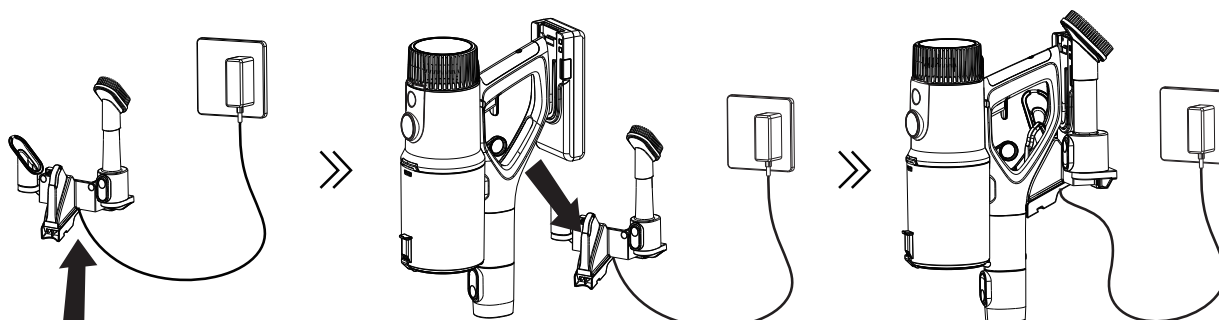

Installing the wall mount (optional)

- 1: Assemble the 2 parts of the wall mount as shown.
- 2: Determine the best wall location for mounting the dock. Be sure an outlet is nearby to connect the power cable.
- 3: We recommend mounting the dock at least 48" from the screw hole to the floor. The mounting height should ensure that the vacuum does not touch the floor while docked.
- 4: Install the wall-mounted dock to the wall with the screws/anchors provided.

Warnings

- We do not recommend mounting the dock if you are unsure of how to properly install the drywall anchors and screws. Consult a professional if you need support.
- Ensure the wall surrounding the mounting area is free of gas, water pipes, electrical cables, wires or other obstructions.

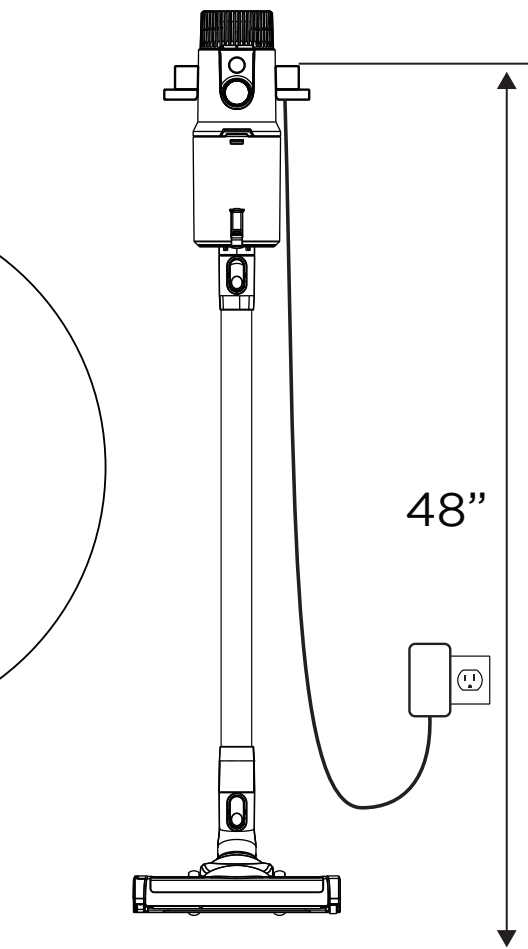
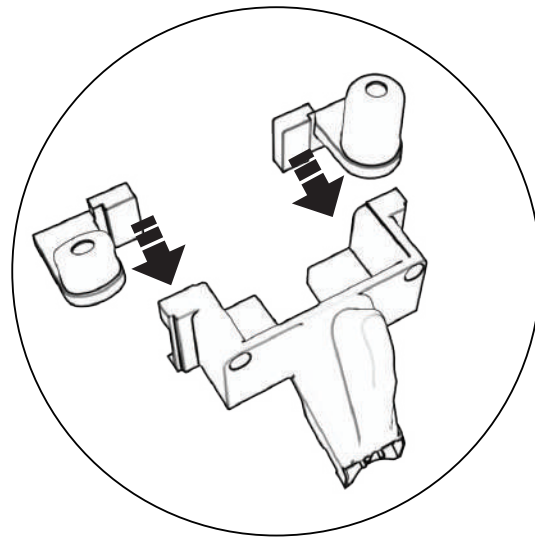

Operation

Note: Designed for indoor use. Do not vacuum liquids.

- Pull the trigger to turn on the vacuum.
- While holding the trigger, slide the optional trigger lock to keep vacuum on. Slide again to release.

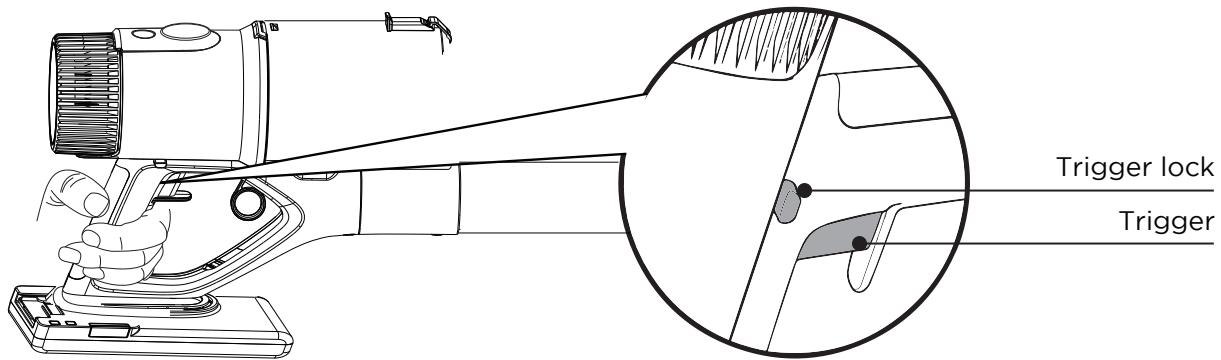

Suction modes

Vacuum will always default to Auto suction mode. When vacuum is in operation, tap the touch sensitive button to toggle between Max, Eco and Auto suction modes.

Your vacuum is equipped with a dust sensor. In Auto mode, the suction power will adjust automatically based on debris/dust sensing.

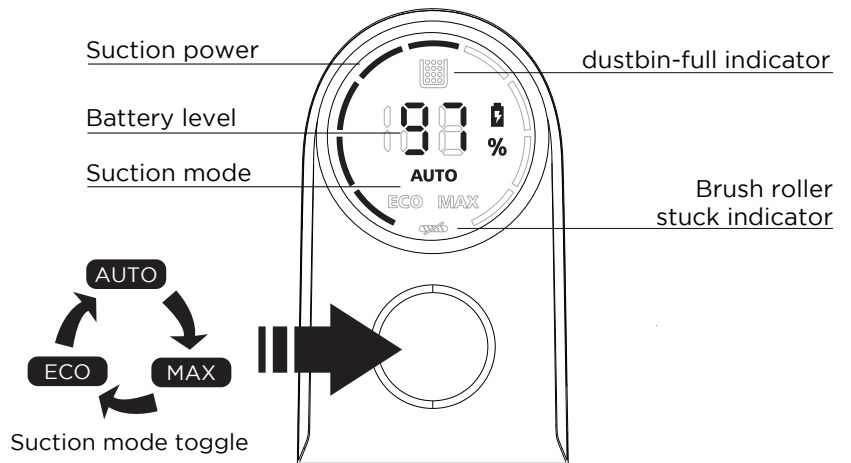

Note: Empty your dustbin & clean filters regularly to ensure optimal performance & longevity of your vacuum.

Emptying the dustbin

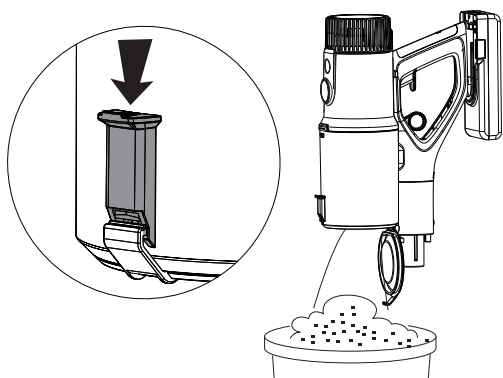

Note: Remove tube/brush attachments before emptying dustbin.

Hold your vacuum over a trash bin, and push down on the dustbin cover latch. Gently tap on the dustbin to ensure all debris is emptied.

Cleaning the filter system

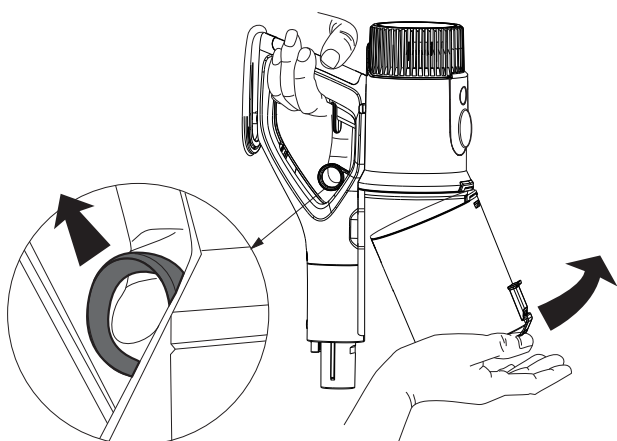

1: Keep one hand under the dustbin and use the other to pull the finger-loop release.

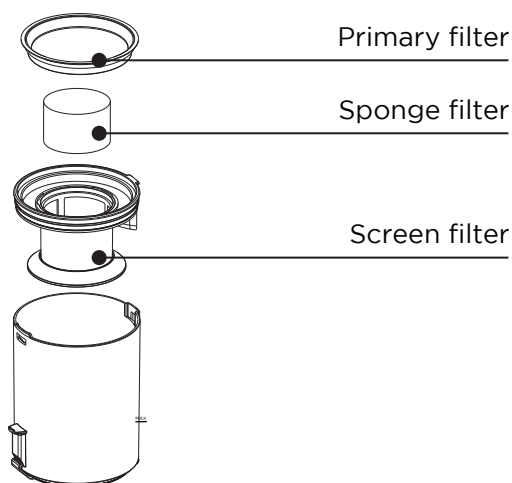

2: Remove and Identify the three filters.

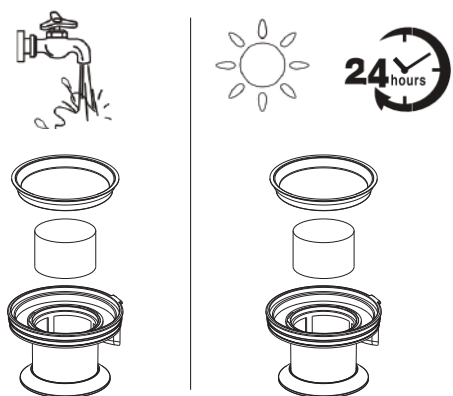

3: rinse under running water. Squeeze excess water from primary and sponge filter. Let dry completely before reassembling.

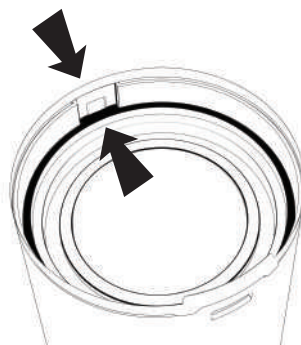

4: Assemble in reverse order. Insert filter assembly into dustbin properly by ensuring that the tabs are lined up.

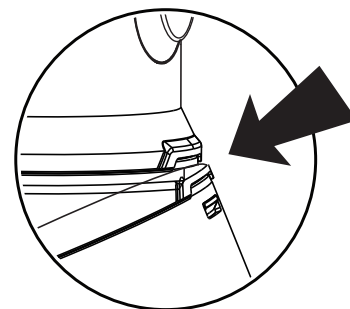

5: Snap Dustbin back onto vacuum by aligning the notches as shown.

Cleaning the floor brush

- 1: Remove the brush from the tube by pressing the release button and pulling apart.
- 2: Remove the clear cover by pulling back on the rounded portion.
- 3: Remove the brushroll by pushing upwards from the bottom left.
- 4: Remove debris/hair wrapped around the roller with a cleaning tool.
- 5: Wipe down the inside of the housing.
- 6: Ensure there is no debris lodged in the neck of the brush assembly or in the metal tube.
- 7: Reinstall the brush as shown.

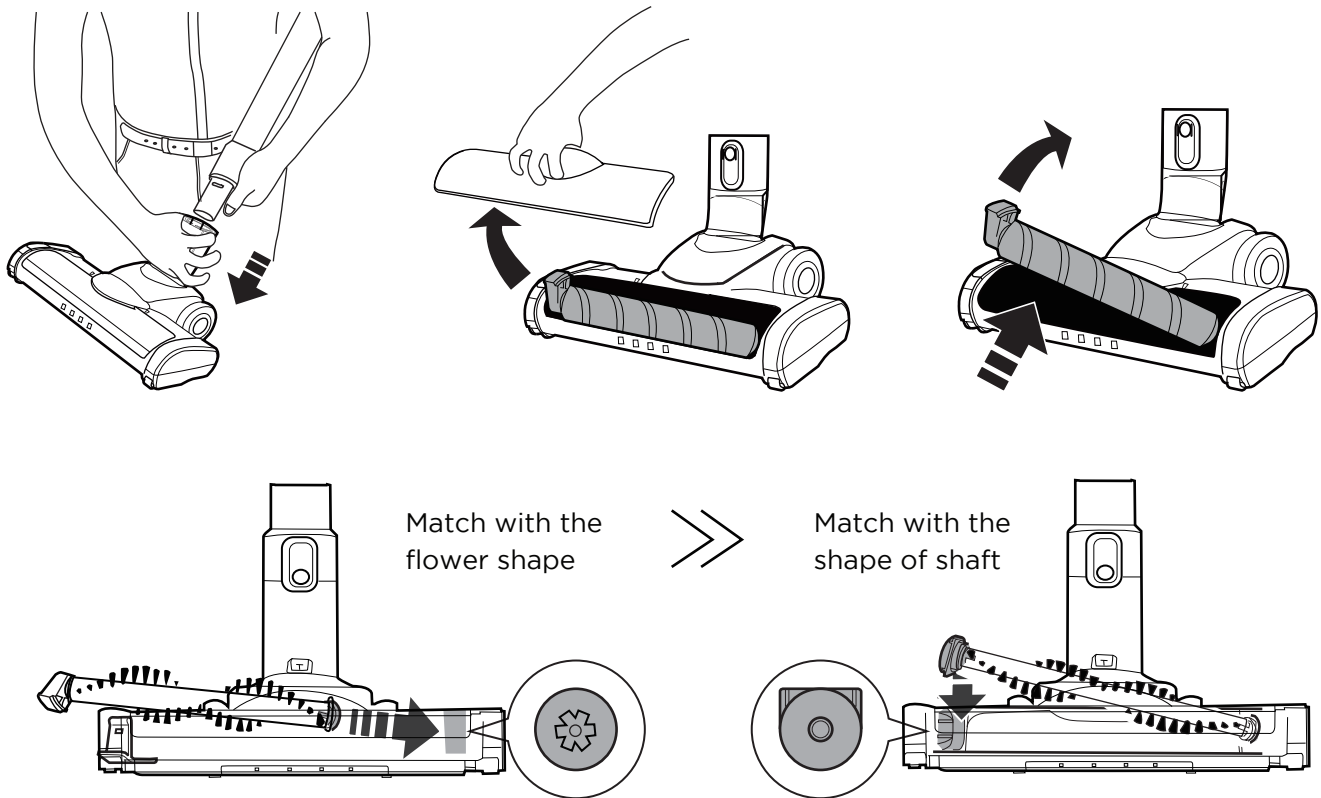

PROBLEM	CAUSE	SOLUTION
Vacuum does not power on	Battery is depleted.	Charge the battery.
	Battery no longer holds a charge.	Visit www.ihomeclean.com to purchase a new battery.
	Battery is still connected to the adapter or vacuum is on the charging mount (standby mode).	Disconnect the battery from the adapter or remove vacuum from the charging mount.
Weak suction power	Dust canister is full.	Empty the dust canister.
	Filters are clogged.	Remove the filters. Wash and dry before reinstalling.
	Brush roller is entangled with hair and debris.	Remove and clean the brush.
	Improper filter installation.	Inspect filters to confirm alignment and proper installation.
	Blocked tube or attachment.	Remove the metal tube and attachments. Clear blockages.
Abnormal motor noise or volume	A blockage may be overworking the motor.	Inspect the dust canister, filters, metal tube, brush roller, or attachments for blockages and remove found debris.
Battery will not charge	The adaptor is not inserted correctly.	Ensure that the adaptor is fully inserted into the battery jack and power source.
	Power source not providing electricity.	Plug another product into your power source to ensure electrical output.
	Adaptor is faulty.	Visit www.ihomeclean.com to purchase a new adaptor.
	Battery is faulty.	Visit www.ihomeclean.com to purchase a new battery.

Questions? Contact customer service

Web/Email: iHomeclean.com

Phone: 877-370-4580

The One (1) Year Limited Warranty applies to purchases made from authorized retailers of Silver Point Innovations LLC. Warranty coverage applies to the original owner and to the original product only and is not transferable. We recommend registering your product online at www.ihomeclean.com

SilverPoint warrants this product to be free from defects in workmanship and materials, under normal household use and conditions, one (1) year from the date of original purchase and maintained according to the requirements outlined in this User Manual. Should this product fail to function in a satisfactory manner, it is best to contact our customer service team at 877-370-4580 so that we may help resolve the matter. Should service be required by reason of any defect or malfunction during the warranty period, SilverPoint will repair or, at its discretion, replace the product.

The One (1) Year Limited Warranty is subject to the following conditions and exclusions:

The original unit and/or non-wearable parts deemed defective, in SilverPoint's sole discretion, will be repaired or replaced up to one (1) year from the original purchase date. In the event a replacement unit is issued the replacement product will be warranted for the remainder of the original warranty period or thirty (30) days from the date of shipment of the replacement product, whichever is longer. SilverPoint reserves the right to use new, refurbished or used parts in good working condition to repair or replace any product.

Exclusions:

(1) Normal wear and tear of wearable parts (such as batteries, brushes, HEPA filters, pads, etc.), which require regular maintenance and/or replacement to ensure the proper functioning of your unit, are not covered by this warranty. Replacement parts are available for purchase at ihomeclean.com. (2) Any unit that has been tampered with or used for commercial purposes. (3) Damage caused by misuse, abuse, negligent handling, failure to perform regular maintenance (i.e., not cleaning the filters), or damage due to mishandling in transit. (4) Consequential and incidental damages. (5) Defects caused by repair persons not authorized by SilverPoint. (6) Products purchased, used, or operated outside of North America.

Claiming Warranty Support:

You must call 877-370-4580 to initiate a warranty claim and have the product on hand during the call. You will need the original receipt as proof of purchase.

The One (1) Year Limited Warranty does not cover the cost of shipping this product to our service center or its return to the owner. Please call Customer Service at 877-370-4580 to obtain shipping instructions.

Disclaimer: This warranty is valid only in the United States of America and does not extend to owners of the product other than to the original purchaser. In no event will SilverPoint or any of its affiliates, contractors, resellers, their officers, directors, shareholders, members or agents be liable to you or any third party for any consequential or incidental damages, any lost profits, actual, exemplary or punitive damages. (Some states do not allow limitations on implied warranties or exclusion of consequential damages, so these restrictions may not apply to you.) This warranty gives you specific legal rights, and you may also have other rights which vary from state to state. Your acknowledgement and agreement to fully and completely abide by this disclaimer of warranty is contractually binding to you upon your transfer of currency (money order, cashier's check, or credit card) for purchase of your SilverPoint product.

