ABSOLUTE STONE

STONE
SOUL

FIVE
SIZES

5
COLORS

PORCELAIN STONEWARE

MADE IN ITALY



Design your life

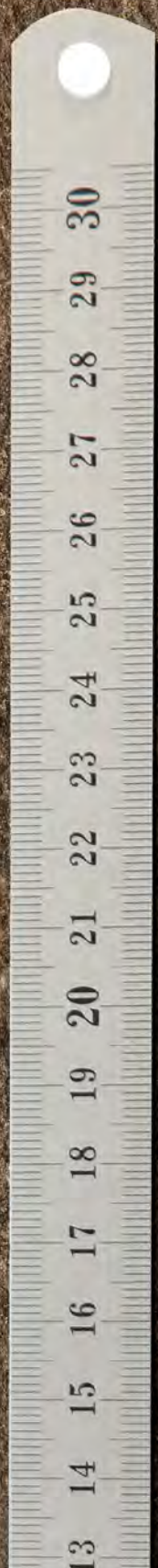

13

14

15

16

17

18

19

20

21

22

23

24

25

26

27

28

29

30

La sensazione autentica
della Pietra, con la durezza e
praticità del gres porcellanato //
Cinque colori di gran carattere,
cinque formati, due finiture
e due spessori //
Un corredo super-completo
per rivestire qualsiasi progetto //

The authentic feel of stone
paired with the hardness
and practicality of porcelain
stoneware // Five striking
colours, five sizes, two
finishes and two thicknesses //
A complete kit to clothe any
project //

Ganz wie ein Stein, mit der
Härte und Zweckmäßigkeit
von Feinsteinzeug // Fünf
großartige Farben, fünf
Formate, zwei Finishes
und zwei Stärken // Ein
ultrakomplettes Angebot für
die Verkleidung aller Arten
von Projekten //

La sensation authentique
de la pierre, avec la dureté
et la commodité du grès
cérame // Cinq couleurs de
caractère, cinq formats, deux
finitions et deux épaisseurs //
Un éventail de choix plus que
complet pour habiller tous
vos projets //

Неподдельный
шарм и очарование
натурального камня,
твердость и практичность
керамогранита //
Пять необычайно
выразительных цветов,
пять форматов, два типа
отделки и две толщины
// Более чем полный
набор для оформления
поверхностей в рамках
любого проекта //

INTO THE SOUL
ABSOLUTE STONE





Cercom trova la sintesi perfetta tra il carisma naturale della pietra, il design essenziale e la praticità di utilizzo oggi irrinunciabili per l'edilizia contemporanea //

Cercom finds the perfect blend of the natural charisma of stone, essential design and practicality of use, which are indispensable to contemporary construction //

Cercom offre un équilibre parfait entre charme naturel de la pierre, design épuré et fonctionnalité, des qualités aujourd'hui incontournables dans le secteur du bâtiment moderne //

Cercom findet die perfekte Synthese zwischen der natürlichen Ausstrahlung von Stein, dem essentiellen Design und der praktischen Anwendung, die für das Bauwesen von heute unerlässlich sind //

Cercom находит идеальный синтез обаяния природного камня, элегантности дизайна и практичности использования, незаменимых элементов для современного строительства //



CREATIVE
SURFACES

Le colorazioni sono ricercate e attuali, la finitura effetto pietra ne esalta la varietà di toni e sfumature // Gli originali decori moltiplicano le soluzioni di posa //

Exquisite and current colours, featuring a stone effect finish that enhances the variety of tones and shades // The original decorations multiply the installation layout options //

Les coloris sont recherchés et tendance, la finition effet pierre met en valeur la diversité des teintes et des nuances // Les décors originaux multiplient les solutions de pose //

Die Färbungen sind edel und hochaktuell, das Finish in Steinoptik hebt die Farbtöne und -nuancen hervor // Die originellen Dekorationen multiplizieren die Lösungen des Verlegens //

Разнообразие тонов и оттенков изысканной и актуальной цветовой палитры обретает особую выразительность благодаря имитации фактуры натурального камня // Оригинальные украшения умножают решения укладки //



RANGE
DETAILS

FIVE
SIZES

100x100
40"x40"

100x100 R11
40"x40"

80x80
32"x32"

60x120
24"x48"

60x120 R11
24"x48"

60x120
24"x48"
19MM

60x60
24"x24"

60x60 R11
24"x24"

30x60
12"x24"

30x60
12"x24"
R11

R10 . R11



RANGE
DETAILS

5
COLORS

MOON

GREY

BLACK

CLAY

GROUND



COMMERCIAL



RESIDENTIAL



8,5 mm
R10



100x100 40"x40"



8,5 mm
R11



100x100 40"x40"

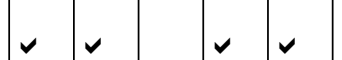

10 mm
R10



30x60 12"x24"



60x60 24"x24"



60x120 24"x48"



80x80 32"x32"



10 mm
R11



30x60 12"x24"

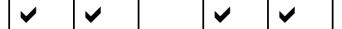

60x60 24"x24"



60x120 24"x48"



19 mm
R11



60x120 24"x48"



INTO THE
SOLUTIONS

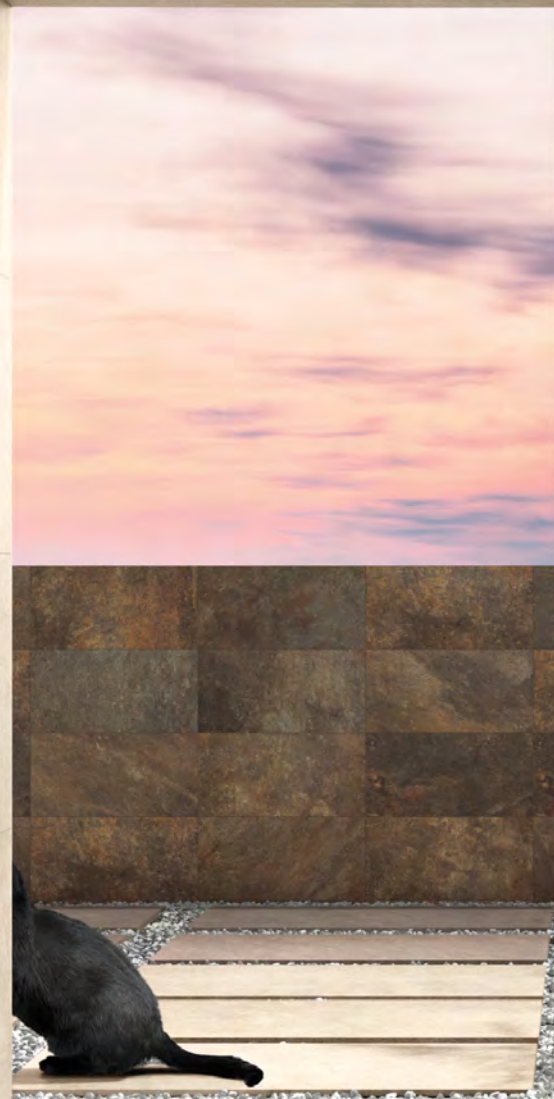

Superfici contemporanee,
formati moderni e prestigiosi
che uniscono design
e praticità //

Il feeling materico e sincero
della pietra naturale in una
interpretazione creativa,
dinamica e moderna //

Contemporary surfaces,
modern and prestigious sizes
that combine design and
practicality //

The material and authentic
feel of natural stone featuring
a creative, dynamic and
modern interpretation //

Des surfaces
contemporaines, des formats
modernes et prestigieux
alliant design et commodité //
L'authenticité et la texture
de la pierre naturelle dans
une interprétation créative,
dynamique et moderne //

Zeitgenössische
Oberflächen, moderne
und prestigeträchtige
Formate, die Design und
Zweckmäßigkeit vereinen //
Das wahre, materialbetonte
Feeling des Natursteins in
einer kreativen, dynamischen
und modernen Interpretation //

Современные
поверхности, актуальные и
востребованные форматы,
сочетающие дизайн и
практичность //
Очарование и самобытная
красота натурального
камня в творческой,
динамической
и современной
интерпретации //



APPLICATIONS GALLERIES

A // HOME GALLERY



20 MASSERIA
MOON



33 LIVING
CLAY



28 BEDROOM
GROUND+CLAY

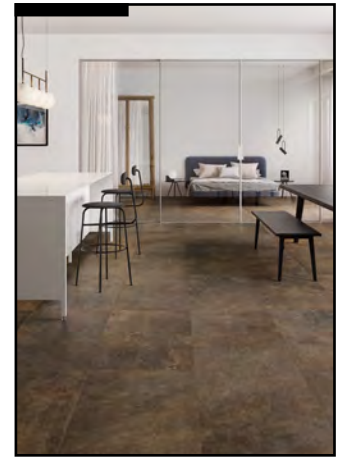

14 OPEN SPACE
GROUND



25 BATHROOM
BLACK

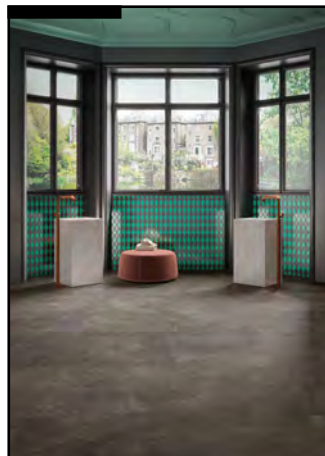

26 BATHROOM
BLACK

B // GARDEN GALLERY



34 RESORT
CLAY



44 PORTICO
GREY



60 SPA
CLAY



52 OFFICE
GREY+BLACK



40 VILLA
MOON



39 PATIO
CLAY



48 RESTAURANT
GREY

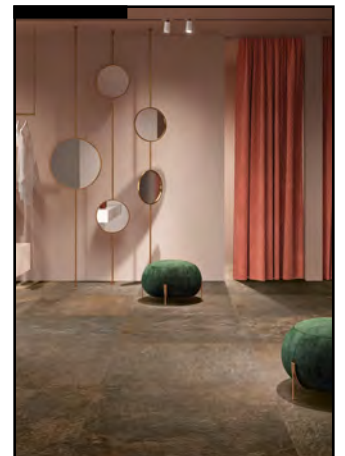

56 SHOP
GROUND

C // CONTRACT GALLERY

A // HOME OPEN SPACE GROUND

floor
GROUND 60x120 . 24"x48" RETT

wall
GROUND LOSANGA 30x30 . 12"x12" RETT







wall

GROUND LOSANGA 30x30 . 12"x12" RETT

L'originale mosaico a
losanga in tinta valorizza il
backsplash della zona cucina
mantenendo la continuità
cromatica con il pavimento //

The original matching
lozenge mosaic enhances
the kitchen backsplash
while maintaining chromatic
continuity with the floor //

L'étonnante mosaïque
assortie en forme de
losange met en valeur la
crédence de la cuisine tout
en maintenant la continuité
chromatique avec le sol //

Das originelle und einfarbige
Rautenmosaik hebt den
Backsplash der Küche
hervor und behält die
farbliche Einheit mit dem
Fußboden bei //

Оригинальная мозаика
в **форме** ромба в тон
придает особую красоту
кухонному фартуку,
сохраняя хроматическую
непрерывность с полом //

floor

GROUND 60x120 . 24"x48" RETT

#MULTIPLE
GRAPHICS

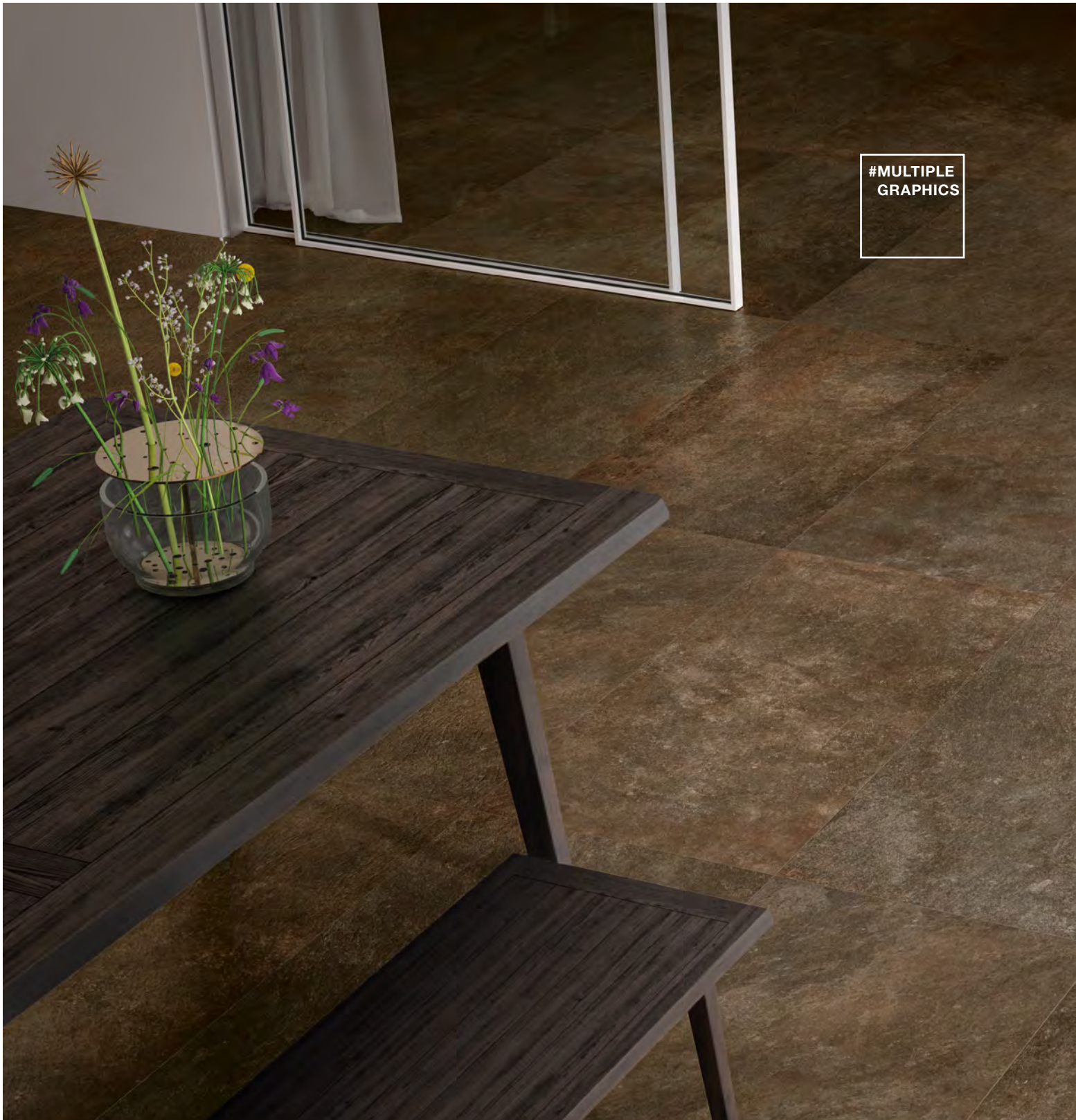



A // HOME MASSERIA MOON

floor

MOON 100x100 . 40"x40" RETT

Absolute Stone sorprende per la grande **versatilità** stilistica e applicativa: è perfetto anche per ristrutturazioni mediterranee, a cui aggiunge un tocco di **personalità ricercata e moderna //**

The great stylistic and functional **versatility** of Absolute Stone is truly astounding: it is also perfectly suited to Mediterranean renovations, bringing a touch of **exquisite and modern personality //**

Absolute Stone surprend par sa grande **versatilité** de style et d'application: il est également idéal pour les rénovations méditerranéennes, auxquelles il apporte une touche de **personnalité recherchée et moderne //**

Absolute Stone überrascht durch seine **vielseitigen** Stillösungen und Anwendungen: perfekt auch für mediterrane Umbauten, denen es einen Hauch von **edler und moderner Persönlichkeit hinzufügt //**

Absolute Stone поражает многообразием **своих стилистических** направлений и возможностей применения: он великолепен также для создания средиземноморского стиля при реконструкции, добавляя интерьерам **индивидуальную нотку изысканности и современности //**





floor

MOON 100x100 . 40"x40" RETT

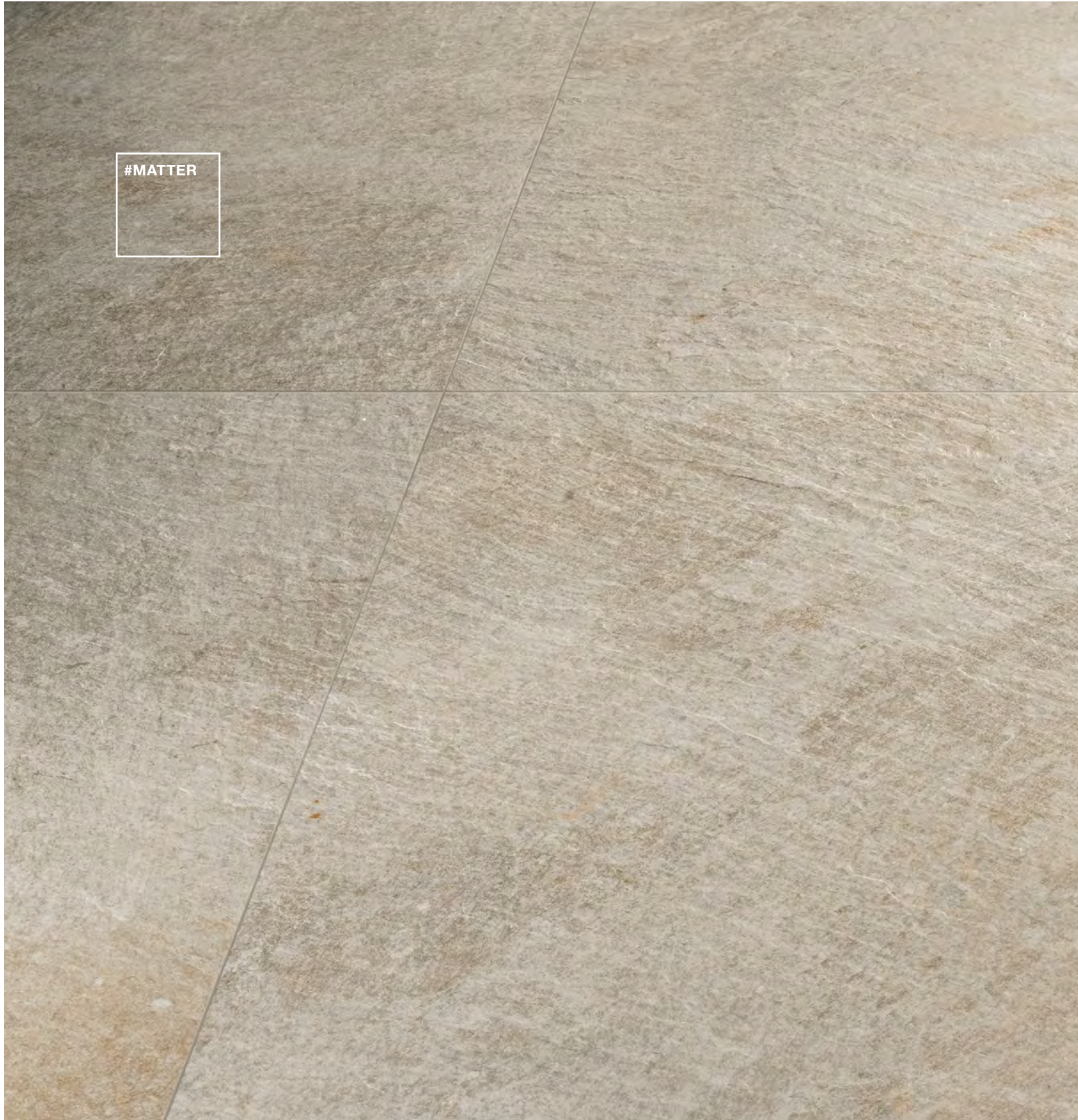



A // HOME BATHROOM BLACK

floor

BLACK 80x80 . 32"x32" RETT

wall

BLACK 60x120 . 24"x48" RETT

Tutti gli spazi interni ed esterni trovano nella finitura **antiscivolo R11** la pavimentazione ideale: non gela, non scolorisce, non si macchia // Disponibile in **tre spessori**, 8,5, 10 e 19mm //

The **R11 non-slip** finish is the ideal flooring for any outdoor space: it is frost resistant, stain proof and does not discolour. Available in **three thicknesses**, 8,5, 10 and 19mm //

Alle Außenräume finden im **rutschfesten Finish R11** ihren idealen Bodenbelag: Es gefriert nicht, es verfärbt sich nicht und es ist fleckenfest. In **drei Stärken**, 8,5, 10 und 19 mm, erhältlich //

Tous les espaces extérieurs trouvent dans la finition **antidérapante R11** le revêtement idéal: il ne craint ni le gel, ni la décoloration, ni les taches. Disponible en **trois épaisseurs**, 8,5, 10 et 19 mm //

Идеальным выбором для оформления всех наружных пространств является плитка с противоскользящим **покрытием R11** – она не замерзает, не теряет насыщенности цвета, не образует пятен. Предлагается в **трёх вариантах толщины** – 8,5, 10 и 19 мм //





floor
BLACK 80x80 . 32"x32" RETT

wall
CERASARDA
Tintùri Alpino 24,5x23 . 9⁵/₈"x9¹/₈"

E.lements
MOON Lavabo a Torre



A // HOME BEDROOM GROUND + CLAY

floor
GROUND 80x80 . 32"x32" RETT

wall
CLAY MOSAICO TESSERA 30x30 . 12"x12" RETT

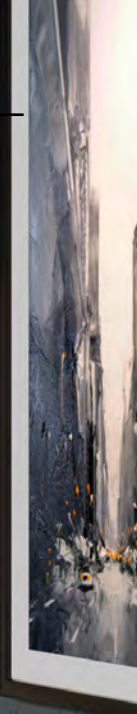



wall

CLAY MOSAICO TESSERA 30x30 . 12"x12" RETT

floor

GROUND 80x80 . 32"x32" RETT

La gamma Absolute Stone
si apre ad applicazioni
originali e creative,
reinventando la ceramica
come **elemento** decorativo
d'arredo //

The Absolute Stone range
is well suited to original
and creative applications,
reinventing ceramics into
a decorative **furnishing**
element //

La gamme Absolute Stone
s'ouvre à des applications
originales et créatives, en
repensant la céramique en
tant **qu'élément décoratif**
d'ameublement //

Das Sortiment Absolute
Stone geht eine Bindung
mit originellen und
kreativen Anwendungen
ein und **erfindet**
Keramik als dekoratives
Einrichtungselement neu //

Коллекция Absolute
Stone открывает
новые возможности
для оригинального и
творческого применения
керамики, **по-новому**
переосмысливая ее как
декоративный элемент
интерьера //

A // HOME LIVING
CLAY

floor
CLAY 100x100 . 40"x40" RETT





B // GARDEN RESORT CLAY

floor

CLAY R11 19MM 60x120 . 24"x48" RETT

CLAY GRADONE COSTA RETTA R11 19MM 35x60x5 . 13³/₄"x24"x2" RETT

CLAY GRIGLIA PER PISCINA R11 19MM 20x60 . 8"x24"RETT

#SPECIAL
PIECES



floor

CLAY R11 19MM 60x120 . 24"x48" RETT

GRADONE COSTA RETTA R11 19MM 35x60x5 . 13³/₄"x24"x2" RETT

GRIGLIA PER PISCINA R11 19MM 20x60 . 8"x24"RETT





floor

CLAY R11 19MM 60x120 . 24"x48" RETT

Le lastre a spessore **19mm** offrono **diverse** opzioni di **posa**: in semplice appoggio su ghiaia o erba, sopraelevata su supporti in plastica o incollata per pavimentazioni anche carrabili //

The **19mm** thick large size tiles offer **different** installation **layout** options: suitable for dry laying on gravel or grass, raised on plastic supports or glued for flooring, including vehicle accessible paving //

Les dalles d'une épaisseur de **19 mm** offrent **différentes** options de **pose**: en simple appui sur le gravier ou l'herbe, surélevées sur des supports en plastique ou collées pour les sols carrossables //

Die Platten der Stärke **19 mm** bieten **unterschiedliche** Lösungen: **Verlegung** direkt auf Kies oder Gras, als Systemboden auf Kunststoff-Stelzlagern oder als Klebeverlegung für auch befahrbare Böden //

Плиты толщиной **19 мм** могут **укладываться** разными **способами**: прямо на гравий или траву, в виде фальшполов на специальные пластиковые опоры или путем приклеивания на полы, в том числе проезжие //



#19MM
THICKNESS

B // GARDEN VILLA MOON

floor

MOON R11 100x100 . 40"x40" RETT

MOON SPECIAL PIECES CUSTOM

MOON R11 19MM 60x120 . 24"x48" RETT

Terrazze e giardini sono **spazi preziosi**, da vivere ogni giorno appena possibile // Absolute Stone offre finiture di superficie specifiche per interni ed esterni, garantendo la perfetta **continuità** estetica in totale sicurezza //

Terraces and gardens are **precious spaces**, to be enjoyed every day as soon as possible // Absolute Stone offers specific surface finishes for interiors and exteriors, guaranteeing perfect aesthetic **continuity** in complete safety //

Terrasses et jardins sont des **espaces précieux** à vivre quotidiennement, dès que le temps le permet // Absolute Stone offre des finitions de surface spécifiques pour l'intérieur et l'extérieur, en garantissant une **continuité** esthétique parfaite, en toute sécurité //

Terrassen und Gärten sind **kostbare Räume**, die es jeden Tag sobald wie möglich zu genießen gilt // Absolute Stone bietet spezielle Oberflächenfinishes für Innen- und Außenräume und garantiert dabei die optische **Kontinuität** in absoluter Sicherheit //

Террасы и сады – это высоко ценимые **открытые пространства**, где мы хотели бы каждый день проводить каждую свободную минуту // Absolute Stone предлагает плиточные поверхности с особой отделкой для интерьеров и экстерьеров, создавая эстетический эффект непрерывности и **обеспечивая** полную безопасность //





floor indoor

MOON 100x100 . 40"x40" RETT

floor outdoor

MOON R11 100x100 . 40"x40" RETT



#IN&OUT
COORDINATED



B // GARDEN PORTICO GREY

floor

GREY 100x100 . 40"x40" RETT

GREY R11 100x100 . 40"x40" RETT

GREY R11 19MM 60x120 . 24"x48" RETT

wall

MOSAICO ABSOLUTE MIX S/2

28,7x29,9 . 11^{5/16}"x12" RETT

#DECOR
IDEAS

floor

GREY 100x100 . 40"x40" RETT

wall

MOSAICO ABSOLUTE MIX S/2 28,7x29,9 . 11⁵/₁₆"x12" RETT

L'estetica e le sfumature di colore sono sapientemente diversificate tra i vari pezzi, **riproducendo** in modo equilibrato e gradevole la variabilità e il feeling delle autentiche pietre naturali //

The aesthetics and shades of colour are expertly diversified among the various pieces, harmoniously and pleasantly **rendering** the diversity and feel of authentic natural stones //

L'esthétique et les nuances de teinte sont savamment variées entre les différentes pièces, **reproduisant** ainsi de façon agréable et équilibrée le caractère fluctuant et authentique de la pierre naturelle //

Die optische Beschaffenheit und die Farbnuancen sind bei diesen Stücken geschickt diversifiziert, **so dass die Vielfalt** und Haptik der echten Natursteine in ausgewogener und ansprechender Weise nachgeahmt werden //

Рисунок и цветовые оттенки искусно варьируются на отдельных плитках, **уравновешенно** и гармонично воспроизводя разнообразие и шарм фактуры натурального камня //





C // CONTRACT RESTAURANT MOON + GREY

floor
GREY 60x120 . 24"x48" RETT

wall
DECORO FERNS BLACK Comp. 2 pz 120x120 . 48"x48" RETT





floor
GREY 60x120 . 24"x48" RETT

wall
DECORO FERNS BLACK Comp. 2 pz 120x120 . 48"x48" RETT





**C // CONTRACT OFFICE
GREY + BLACK**

floor
GREY 80x80 . 32"x32" RETT

wall
BLACK 60x120 . 24"x48" RETT

Creativity is contagious. Pass it on.

A. Einstein







#MATTER

La superficie è caratterizzata da una **leggera struttura**, che riproduce i rilievi naturali e l'effetto estetico della pietra, ma resta sempre estremamente facile da pulire e resistente alle macchie //

The surface is characterized by a **light structure**, which mimics the natural texture and the aesthetic effect of the stone, but is extremely easy to clean and stain proof //

La surface est caractérisée par une **légère structure**, qui reproduit les reliefs naturels et l'effet esthétique de la pierre, mais reste toutefois extrêmement facile à nettoyer et résistante aux taches //

Die leichte Oberflächenstruktur ahmt das natürliche Relief und die optische Wirkung von Stein nach, bleibt aber fleckenfest und ist mühelos leicht zu reinigen //

Поверхность отличается **легкой шероховатостью**, которая воспроизводит естественную рельефность и эстетический эффект натурального камня, но при этом сохраняет чрезвычайную простоту в уходе и устойчивость к образованию пятен //



floor
BLACK 60x120 . 24"x48" RETT

floor
GREY 80x80 . 32"x32" RETT

C // CONTRACT SHOP GROUND

floor

GROUND 100x100 . 40"x40" RETT

La resistenza all'usura e al calpestio fanno di Absolute Stone una pavimentazione **ideale** anche per spazi **commerciali** //

Resistance to wear and footfall make Absolute Stone an **ideal** flooring also for **commercial** spaces //

La résistance à l'usure et au piétinement fait d'Absolute Stone un revêtement **idéal** pour les espaces **commerciaux** //

Durch die abrieb- und trittfeste Eigenschaft verwandelt sich Absolute Stone in einen **idealen** Bodenbelag auch für **Geschäftsräume** //

Устойчивость к износу, в том числе в условиях интенсивного пешеходного движения, делает Absolute Stone идеальным **напольным** покрытием также и для коммерческих **пространств** //

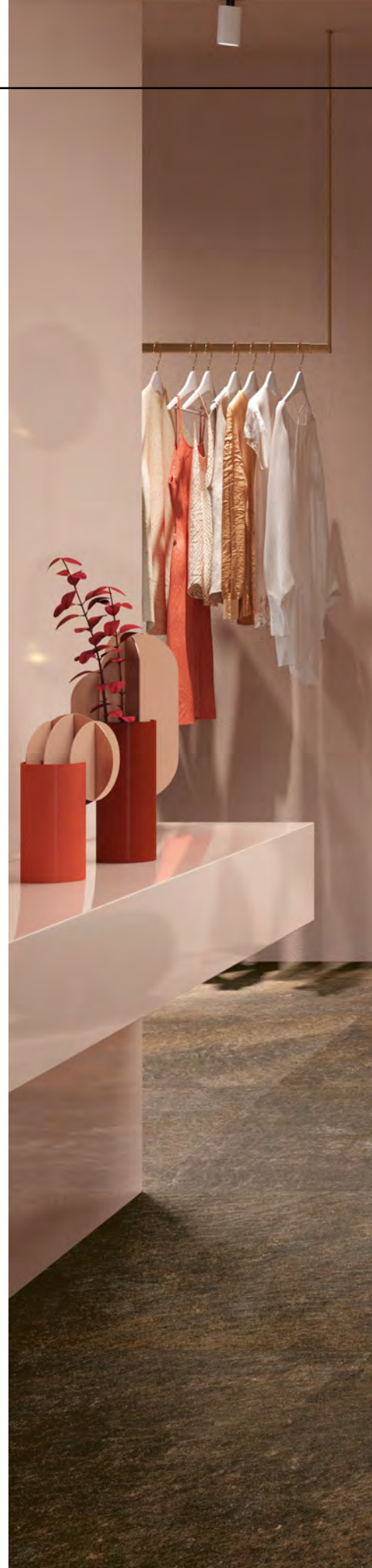



floor
GROUND 100x100 . 40"x40" RETT





C // CONTRACT SPA CLAY

floor indoor

CLAY R11 60x120 . 24"x48" RETT

floor outdoor

CLAY R11 60x60 . 24"x24" RETT

wall

GREY MOSAICO TESSERA 30x30 . 12"x12" RETT

Progettisti di aree wellness trovano nell'assortimento Absolute Stone un **completo set di superfici** coordinate con pavimenti, rivestimenti, mosaici e superfici R11 A+B non scivolose anche a piedi nudi //

The Absolute Stone assortment is the perfect solution for Wellness area designers: a **complete set of colour-coordinated surfaces** with floor, wall and mosaic tiles as well as R11 A+B surfaces that are non-slippery even with bare feet //

Les concepteurs d'espaces bien-être trouvent dans la collection Absolute Stone un **ensemble complet de surfaces** assorties avec des sols, des revêtements, des mosaïques et des surfaces R11 A+B antidérapantes, y compris pieds nus //

Planer von Wellnessbereichen finden im Sortiment von Absolute Stone **ein komplettes Angebot an aufeinander abgestimmten Oberflächen** wie Bodenbelägen, Wandverkleidungen, Mosaiken und - auch barfuß - rutschfesten Oberflächen R11 A+B //

Проектировщики велнес-зон найдут в ассортименте Absolute Stone **полный набор скоординированных поверхностей** для пола и стен, мозаику и противоскользящую плитку R11 A + B, которая не скользит даже при хождении босиком //







#R11
SURFACE

floor indoor
CLAY R11 60x120 . 24"x48" RETT
floor outdoor
CLAY R11 60x60 . 24"x24" RETT

wall
GREY MOSAICO TESSERA 30x30 . 12"x12" RETT



MOON

R10
RETT

R11
RETT

A+B+C
19 MM



V3

8,5 MM
5/16"

10 MM
3/8"

19 MM
13/16"

GRES PORCELLANATO SMALTATO COLORATO IN MASSA . GLAZED PORCELAIN STONEWARE WITH COLOURED BODY . GRÈS CÉRAME ÉMAILLÉ COLORÉ DANS LA MASSE
GLASIERTES FEINSTEINZEUG IN DER MASSE GEFÄRBT . ГЛАЗУРОВАННЫЙ КЕРАМОГРАНИТ, ОКРАШЕННЫЙ ПО ВСЕЙ ТООЛЩИНЕ



NAT
R10 RETT



R11
R11 RETT

Sizes

	NAT	R11
8,5 MM 5/16"		
 100x100 . 40"x40" RETT	□	□
10 MM 3/8"		
 80x80 . 32"x32" RETT	□	
 60x120 . 24"x48" RETT	□	□
 60x60 . 24"x24" RETT	□	□
 30x60 . 12"x24" RETT	□	□
19 MM 13/16"		
 60x120 . 24"x48" RETT		□

Mosaics

	NAT
10 MM 3/8"	
 Mosaico Tessera 5x5 . 2"x2" 30x30 . 12"x12" RETT	□
 Mosaico Losanga 30x30 . 12"x12" RETT	□
 Mosaico Esagona Absolute Mix 28,7x29,9 . 11 ⁵ / ₁₆ "x12" RETT	□

Pezzi speciali . Special pieces . Pièces spéciales
Formteile . Специальные элементы: Pag. 70

GREY



GRES PORCELLANATO SMALTATO COLORATO IN MASSA . GLAZED PORCELAIN STONEWARE WITH COLOURED BODY . GRÈS CÉRAME ÉMAILLÉ COLORÉ DANS LA MASSE
 GLASIERTES FEINSTEINZEUG IN DER MASSE GEFÄRBT . ГЛАЗУРОВАННЫЙ КЕРАМОГРАНИТ, ОКРАШЕННЫЙ ПО ВСЕЙ ТООЛЩИНЕ



NAT
R10 RETT



R11
R11 RETT

Sizes

	NAT	R11
8,5 MM 5/16"		
 100x100 . 40"x40" RETT	<input type="checkbox"/>	<input type="checkbox"/>
10 MM 3/8"		
 80x80 . 32"x32" RETT	<input type="checkbox"/>	
 60x120 . 24"x48" RETT	<input type="checkbox"/>	<input type="checkbox"/>
 60x60 . 24"x24" RETT	<input type="checkbox"/>	<input type="checkbox"/>
 30x60 . 12"x24" RETT	<input type="checkbox"/>	<input type="checkbox"/>
19 MM 13/16"		
 60x120 . 24"x48" RETT		<input type="checkbox"/>

Mosaics

	NAT
10 MM 3/8"	
 Mosaico Tessera 5x5 . 2"x2" 30x30 . 12"x12" RETT	<input type="checkbox"/>
 Mosaico Losanga 30x30 . 12"x12" RETT	<input type="checkbox"/>
 Mosaico Esagona Absolute Mix 28,7x29,9 . 115/16"x12" RETT	<input type="checkbox"/>

Pezzi speciali . Special pieces . Pièces spéciales
 Formteile . Специальные элементы: Pag. 70

BLACK

R10
RETT

R11
R11

A+B+C
19 MM



V3

8,5 MM
5/16"

10 MM
3/8"

19 MM
13/16"

GRES PORCELLANATO SMALTATO COLORATO IN MASSA . GLAZED PORCELAIN STONEWARE WITH COLOURED BODY . GRÈS CÉRAME ÉMAILLÉ COLORÉ DANS LA MASSE
GLASIERTES FEINSTEINZEUG IN DER MASSE GEFÄRBT . ГЛАЗУРОВАННЫЙ КЕРАМОГРАНИТ, ОКРАШЕННЫЙ ПО ВСЕЙ ТООЛЩИНЕ



NAT
R10 RETT

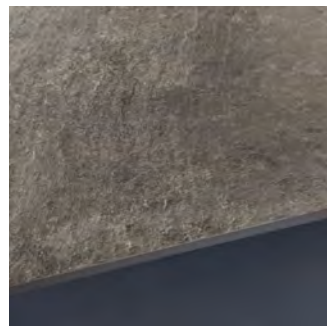

R11
R11 RETT

Sizes

	NAT	R11
8,5 MM 5/16"		
 100x100 . 40"x40" RETT	□	
10 MM 3/8"		
 80x80 . 32"x32" RETT	□	
 60x120 . 24"x48" RETT	□	
 60x60 . 24"x24" RETT	□	
 30x60 . 12"x24" RETT	□	
19 MM 13/16"		
 60x120 . 24"x48" RETT		

Mosaics

	NAT
10 MM 3/8"	
 Mosaico Tessera 5x5 . 2"x2" 30x30 . 12"x12" RETT	□
 Mosaico Losanga 30x30 . 12"x12" RETT	□
 Mosaico Esagona Absolute Mix 28,7x29,9 . 11 ⁵ / ₁₆ "x12" RETT	□

Pezzi speciali . Special pieces . Pièces spéciales
Formteile . Специальные элементы: Pag. 70

CLAY



GRES PORCELLANATO SMALTATO COLORATO IN MASSA . GLAZED PORCELAIN STONEWARE WITH COLOURED BODY . GRÈS CÉRAME ÉMAILLÉ COLORÉ DANS LA MASSE
 GLASIERTES FEINSTEINZEUG IN DER MASSE GEFÄRBT . ГЛАЗУРОВАННЫЙ КЕРАМОГРАНИТ, ОКРАШЕННЫЙ ПО ВСЕЙ ТООЛЩИНЕ



NAT
R10 RETT

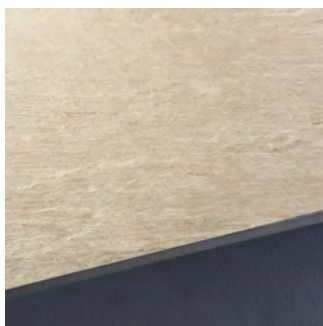

R11
R11 RETT

Sizes

	NAT	R11
8,5 MM 5/16"		
 100x100 . 40"x40" RETT	<input type="checkbox"/>	<input type="checkbox"/>
10 MM 3/8"		
 80x80 . 32"x32" RETT	<input type="checkbox"/>	
 60x120 . 24"x48" RETT	<input type="checkbox"/>	<input type="checkbox"/>
 60x60 . 24"x24" RETT	<input type="checkbox"/>	<input type="checkbox"/>
 30x60 . 12"x24" RETT	<input type="checkbox"/>	<input type="checkbox"/>
19 MM 13/16"		
 60x120 . 24"x48" RETT		<input type="checkbox"/>

Mosaics

	NAT
10 MM 3/8"	
 Mosaico Tessera 5x5 . 2"x2" 30x30 . 12"x12" RETT	<input type="checkbox"/>
 Mosaico Losanga 30x30 . 12"x12" RETT	<input type="checkbox"/>
 Mosaico Esagona Absolute Mix 28,7x29,9 . 115/16"x12" RETT	<input type="checkbox"/>

Pezzi speciali . Special pieces . Pièces spéciales
 Formteile . Специальные элементы: Pag. 70

GROUND

R10
RETT

R11
R11

A+B+C
19 MM



V3

8,5 MM
5/16"

10 MM
3/8"

19 MM
13/16"

GRES PORCELLANATO SMALTATO COLORATO IN MASSA . GLAZED PORCELAIN STONEWARE WITH COLOURED BODY . GRÈS CÉRAME ÉMAILLÉ COLORÉ DANS LA MASSE
GLASIERTES FEINSTEINZEUG IN DER MASSE GEFÄRBT . ГЛАЗУРОВАННЫЙ КЕРАМОГРАНИТ, ОКРАШЕННЫЙ ПО ВСЕЙ ТООЛЩИНЕ



NAT
R10 RETT

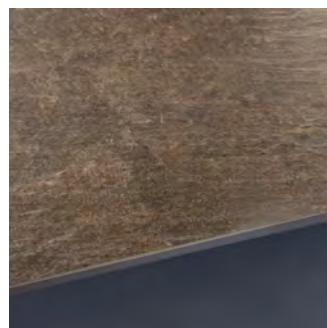

R11
R11 RETT

Sizes

	NAT	R11
8,5 MM 5/16"		
 100x100 . 40"x40" RETT	□	□
10 MM 3/8"		
 80x80 . 32"x32" RETT	□	
 60x120 . 24"x48" RETT	□	□
 60x60 . 24"x24" RETT	□	□
 30x60 . 12"x24" RETT	□	□
19 MM 13/16"		
 60x120 . 24"x48" RETT		□

Mosaics

	NAT
10 MM 3/8"	
 Mosaico Tessera 5x5 . 2"x2" 30x30 . 12"x12" RETT	□
 Mosaico Losanga 30x30 . 12"x12" RETT	□
 Mosaico Esagona Absolute Mix 28,7x29,9 . 11 ⁵ / ₁₆ "x12" RETT	□

Pezzi speciali . Special pieces . Pièces spéciales
Formteile . Специальные элементы: Pag. 70

MOSAICI

MOSAICS . MOSAÏQUES . MOSAIKEN . МОЗАИКА

MOSAICO TESSERA

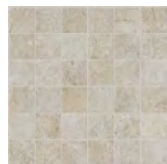

MOON
30x30 . 12"x12" RETT
tessera 5x5 . 2"x2"

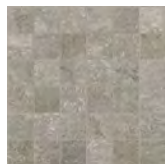

GREY
30x30 . 12"x12" RETT
tessera 5x5 . 2"x2"

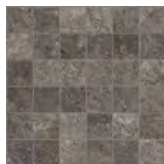

BLACK
30x30 . 12"x12" RETT
tessera 5x5 . 2"x2"

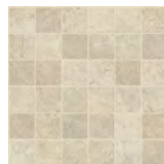

CLAY
30x30 . 12"x12" RETT
tessera 5x5 . 2"x2"

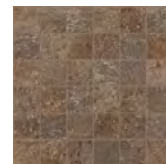

GROUND
30x30 . 12"x12" RETT
tessera 5x5 . 2"x2"

MOSAICO LOSANGA



MOON
30x30 . 12"x12" RETT



GREY
30x30 . 12"x12" RETT



BLACK
30x30 . 12"x12" RETT



CLAY
30x30 . 12"x12" RETT



GROUND
30x30 . 12"x12" RETT

MOSAICO ABSOLUTE MIX

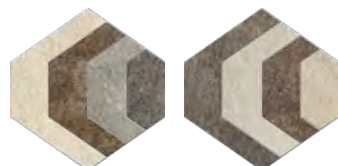

ESAGONA MIX S/2
28,7x29,9 . 11⁵/₁₆"x12" RETT

DECORI

DECORS . DÉCORS . DEKORE . ДЕКОРЫ



DECORO FERNS BLACK
Comp. 2 pz 120x120 . 48"x48" RETT



DECORO FERNS GROUND
Comp. 2 pz 120x120 . 48"x48" RETT

Fasce di prezzo
Price ranges . Grupes des prix
Preisgruppen

10 MM ³/₈"



Mosaico Tessera
30x30 . 12"x12" RETT



● B13



Mosaico Losanga
30x30 . 12"x12" RETT



● B25



Mosaico Esagona
Absolute Mix
28,7x29,9 . 11⁵/₁₆"x12"
RETT



● B17

Fasce di prezzo
Price ranges . Grupes des prix
Preisgruppen

10 MM ³/₈"



Decoro Ferns
Comp. 2 pz
120x120 . 48"x48" RETT

● B66

PEZZI SPECIALI

TRIMS . PIÈCES SPÉCIALES . FORMSTÜCKE . СПЕЦИАЛЬНЫЕ ИЗДЕЛИЯ



Battiscopa
6,5x100 . 2 9/16"x40" RETT



► C7



Battiscopa
7,5x80 . 3"x32" RETT



► C7

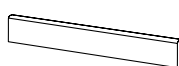

Battiscopa
6,5x60 . 2 9/16"x24" RETT



► C5

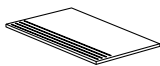

Step molato
30x60 . 12"x24" RETT



● B24

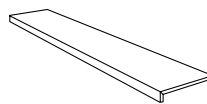

Gradone costa retta
30x120x3,3 . 12"x48"x1 5/16" RETT



● B51

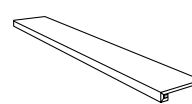

Gradone square assembled
30x120x3,3 . 12"x48"x1 5/16" RETT



● B62



Coppia Angolo Griglia (2 pz) R11
20x60 . 8"x24" rett



comp. ● B63B

Griglia per Piscina R11
20x60 . 8"x24" rett



● B56

Step Molato R11
30x60 . 12"x48" rett



● B53

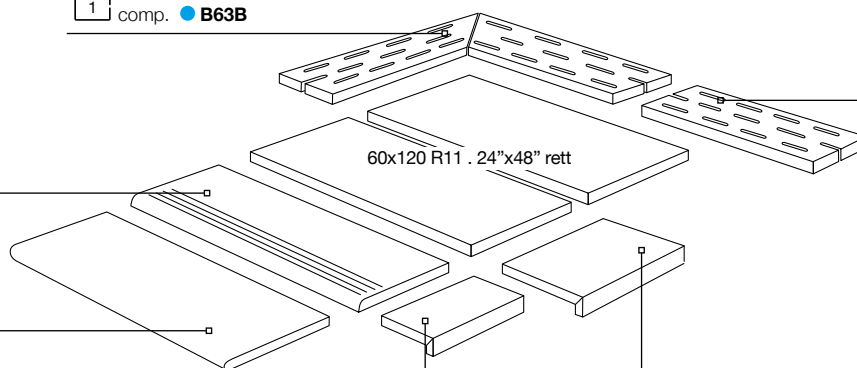

60x120 R11 . 24"x48" rett

Step Torato R11
30x120 . 12"x48" rett



● B55

Gradone Costa Retta R11
35x60x5 . 13 3/4" x24"x2" rett



● B52

Elemento ad "L" assembled R11
15x60x5 . 6"x24"x2" rett



● B43

PACKING

	Fasce di prezzo Price ranges Grupes des prix Preisgruppen	PCS // BOX	SQM // BOX	KGS // BOX	BOXES // PALLET	SQM // PALLET	KGS // PALLET
8,5 MM 5/16"							
100x100 . 40"x40" RETT	■ A32	1	1,00	20,65	42	42,00	900
100x100 . 40"x40" RETT R11	■ A34	1	1,00	20,65	42	42,00	900
10 MM 3/8"							
80x80 . 32"x32" RETT	■ A27	2	1,28	28,50	44	56,32	1274
60x120 . 24"x48" RETT	■ A31	2	1,44	32,00	36	51,84	1168
60x60 . 24"x24" RETT	■ A15	3	1,08	24,00	40	43,20	976
30x60 . 12"x24" RETT	■ A10	6	1,08	23,80	40	43,20	970
10 MM 3/8"							
60x120 . 24"x48" RETT R11	■ A33	2	1,44	32,00	36	51,84	1168
60x60 . 24"x24" RETT R11	■ A17	3	1,08	24,00	40	43,20	976
30x60 . 12"x24" RETT R11	■ A12	6	1,08	23,80	40	43,20	970
19 MM 13/16"							
60x120 . 24"x48" RETT R11	■ A46	1	0,72	30,60	36	25,92	1118

LISTINO PREZZI

PRICE LIST - TARIF - PREISLISTE - ПРАЙС-ЛИСТ

Fasce di prezzo Price ranges Grupes des prix Preisgruppen	1° Scelta Mq 1st Choice Sqm 1 Choix Mc 1 Wahl Qm	1° Scelta Mq Paletta Frazionata
A10	€ 52,00	€ 57,00
A12	€ 54,00	€ 59,00
A15	€ 57,00	€ 63,00
A17	€ 59,00	€ 65,00
A27	€ 70,00	€ 77,00
A31	€ 74,00	€ 81,00
A32	€ 75,00	€ 82,00
A33	€ 76,00	€ 83,00
A34	€ 77,00	€ 84,00
A46	€ 94,00	€ 101,00

*

IL PREZZO DELLA SCELTA COMMERCIALE, SE DISPONIBILE, È DEL -50% DAL PREZZO DELLA 1° SCELTA PALETTE COMPLETE

FOR COMMERCIAL GRADE TILES, IF AVAILABLE, A DISCOUNT OF 50% ON THE PRICE OF THE 1ST CHOICE TILES IN WHOLE PALLET IS APPLIED

LE PRIX DU CHOIX COMMERCIAL, SI DISPONIBILE, EST DE -50 % PAR RAPPORT AU PRIX DU 1ER CHOIX PALETTE COMPLETE

DER PREIS FÜR DIE HANDELSORTIERUNG BETRÄGT, WENN VERFÜGBAR, 50 % WENIGER ALS DER PREIS FÜR DIE 1. WAHL.

Fasce di prezzo Price ranges Grupes des prix Preisgruppen	1° Scelta Pz 1st Choice Piece 1 Choix Unite 1 Wahl Stück
B13	€ 15,00
B17	€ 19,00
B24	€ 26,00
B25	€ 27,00
B43	€ 74,00
B51	€ 94,00
B52	€ 96,00
B53	€ 103,00
B55	€ 107,00
B56	€ 120,00
B62	€ 150,00
B63B	€ 220,00
B66	€ 340,00

Fasce di prezzo Price ranges Grupes des prix Preisgruppen	1° Scelta ml 1st choice linear metre 1er choix ml 1. Wahl Lfm.
C5	€ 16,00
C7	€ 18,00

■ **Prezzo al m²**
Price x sqm . Prix / m²
Preis x qm . Цена за квадратный метр

● **Prezzo al pezzo**
Price per piece . Prix a l' unite
Preis pro Stück . Цена за штуку











▶ **Prezzo al m lineare**
Price per linear metre . Prix au m linéaire
Wahl Lfm. . Цена за погонный м

TUTTI I DECORI E I BATTISCOPA SONO VENDUTI A SCATOLE INTERE.
ALL DECORS AND BASEBOARDS ARE SOLD IN FULL BOXES.
TOUS LES DECORS ET LES PLINTHES SONT VENDUS PAR BOÎTES COMPLÈTES.
FORMTEILVERKAUF NUR KARTONSWEISE MÖGLICH.

IVA E TRASPORTO ESCLUSI, PALLET FAO € 8,00, MINI PALLET FAO € 4,70
VAT AND TRANSPORT NOT INCLUDED, PALLET FAO € 8,00, MINI PALLET FAO € 4,70
TVA ET TRANSPORT NON INCLUS, PALLET FAO € 8,00, MINI PALLET FAO € 4,70
MWST UND TRANSPORT NICHT INBEGRIFFEN, PALLET FAO € 8,00, MINI PALLET FAO € 4,70

CARATTERISTICHE TECNICHE

TECHNICAL FEATURES . CARACTÉRISTIQUES TECHNIQUES . TECHNISCHE EIGENSCHAFTEN . ТЕХНИЧЕСКИЕ ХАРАКТЕРИСТИКИ

GRES PORCELLANATO SMALTATO COLORATO IN MASSA - ISO 13006 Bla GL GLAZED PORCELAIN STONEWARE WITH COLOURED BODY . GRÈS CÉRAME ÉMAILLÉ COLORÉ DANS LA MASSE GLASIERTES FEINSTEINZEUG IN DER MASSE GEFÄRBT . ГЛАЗУРОВАННЫЙ КЕРАМОГРАНИТ, ОКРАШЕННЫЙ ПО ВСЕЙ ТОЛЩИНЕ			
	Aspetto superficiale Surface appearance Aspect superficiel Oberflächenbeschaffenheit Вид поверхности	≥ 95%	Conforme Compliant Conforme Konform Соответствует
 UNI EN ISO 10545-2	Lunghezza e larghezza Length and width Longueur et largeur Länge und Breite Длина и ширина	Deviazione valore medio % rispetto a dimensione di fabbricazione. Deviation of the average size for each tile from the work size (%). Écart dimensionnel moyen en % par rapport aux dimensions de fabrication. Abweichung des Durchschnittswertes in % hinsichtlich der Produktionsgröße. Отклонение средн. значения, % от производственных размеров > 410 cm2 +/- 0,6% - ≤ 410 cm2 +/- 0,75%	± 0,5% ± 1,5 mm
		Deviazione valore medio % rispetto a dimensione di fabbricazione. Deviation of the average size from the average size to the 10 test specimens (%). Écart de valeur moyenne unitaire % en rapport à la valeur moyenne de 10 échantillons mesurés. Abweichung des Durchschnittswertes der einzelnen Fliesen in % hinsichtlich des Durchschnitts von 10 getesteten Mustern. Отклонение средн. значения, отдельной плитки относительно средн. значения 10 измеренных образцов +/- 0,5%	± 0,5% ± 1,5 mm
	Rettilineità degli spigoli Straightness of sides Rectitude des arêtes Kantengeradheit Прямолинейность кромок	+/- 0,5%	± 0,3% ± 1,5 mm
	Spessore / Thickness / Épaisseur/Stärke / Толщина	+/- 5%	± 5% ± 0,5 mm
	Ortogonalità Rectangularity Orthogonalité Rechtwinkigkeit Ортогональность	+/- 0,5%	± 0,3% ± 1,5 mm
 UNI EN ISO 10545-3	Assorbimento d'acqua Water absorption Absorption d'eau Wasseraufnahme Водопоглощение	≤ 0,5% GRUPPO Bla GL	E ≤ 0,1%
	Resistenza della superficie (scala MOHS) Scratch hardness (MOHS scale) Dureté de la surface (échelle MOHS) Oberflächenhärte (MOHS skala) Поверхностная прочность по (шкале Мооса)	EN 101	> 6
 UNI EN ISO 10545-4	Resistenza a flessione e forza di rottura Modulus of rupture and breaking strength résistance à la flexion et force de rupture Biegefestigkeit und Bruchlast Прочность на изгиб Модуль жесткости	S ≥ 1300 N	S ≥ 1300 N
		R ≥ 35 N/mm2	R ≥ 35 N/mm2
 UNI EN ISO 10545-7	Resistenza alla abrasione della superficie di piastrelle smaltate Resistance to surface abrasion of glazed tiles Résistance à l'abrasion de la surface des carreaux émaillés Widerstand gegen Abrieb der Oberfläche der glasierten Fliesen Стойкость глазурованной плитки к поверхностному истиранию	Come dichiarato dal produttore See manufacturer's declaration Selon déclaration du producteur Entsprechend der Herstellerangaben Как указано изготовителем	Classe 3-4 Class 3-4 Classe 3-4 Gruppe 3-4 Класс 3-4
 UNI EN ISO 10545-8	Coefficiente di dilatazione termica lineare Linear thermal expansion coefficient Dilatation thermique linéaire Lineare Wärmeausdehnung Кoeffициент линейного теплового расширения	Come dichiarato dal produttore See manufacturer's declaration Selon déclaration du producteur Entsprechend der Herstellerangaben Как указано изготовителем	Metodo disponibile Method available Méthode disponible Verfügbares verfahren Определяется производителем
 UNI EN ISO 10545-9	Resistenza allo shock termico Thermal shock resistance Résistance au choc thermique Temperaturwechselbeständigkeit Стойкость к тепловым перепадам	Nessun campione deve presentare alterazioni No sample must show visible alteration Aucun carreau ne doit présenter d'altération Kein Muster darf sichtbare Veränderungen zeigen Никакой образец не должен показывать изменений	Resistente Resistant Résistant Widerstandsfähig Устойчивый
 UNI EN ISO 10545-12	Resistenza al gelo Frost resistance Résistance au gel Frostbeständigkeit Морозостойкость	Non devono presentare difetti visibili No sample must show visible defect Aucun carreau ne doit présenter de défaut Muster dürfen keine sichtbaren Schäden zeigen Не должны обнаруживать видимые дефекты	Ingelivo Frost proof Ingeif Frostsicher Морозостойкость
 UNI EN ISO 10545-13	Resistenza all'attacco chimico (tranne acido fluoridrico) Resistance to chemical attack (except hydrofluoric acid) Résistance à l'attaque chimique (sauf acide fluoridrique) Säure- und Laugenbeständigkeit (außer Flußsäure) Стойкость к бытовым химикатам	Nessun campione deve presentare alterazioni No sample must show visible alteration Aucun carreau ne doit présenter d'altération Muster dürfen keine sichtbaren Veränderungen zeigen Никакой образец не должен показывать изменений	Classe A-HA-LA Class A-HA-LA Classe A-HA-LA Gruppe A-HA-LA Класс A-HA-LA
 UNI EN ISO 10545-14	Resistenza alle macchie di piastrelle smaltate Resistance to stains of glazed tiles Résistance aux taches des carreaux émaillés Widerstand gegen Fleckenbildner der glasierten Fliesen Стойкость глазурованной плитки к образованию пятен	Nessun campione deve presentare alterazioni No sample must show visible alteration Aucun carreau ne doit présenter d'altération Muster dürfen keine sichtbaren Veränderungen zeigen Никакой образец не должен показывать изменений	Classe 5 Class 5 Classe 5 Gruppe 5 Класс 5
 B.C.R.A. REP. CEC. 6/81 DIN 51130 DIN 51097	Resistenza alla scivolosità. Coefficiente di attrito medio Skid resistance. Average coefficient of friction Résistance au glissement. Coefficient de frottement moyen Rutschfestigkeit. Mittlerer Reibungswert Сопротивление скольжению. Средний коэффициент трения	B.C.R.A. REP. CEC. 6/81 (NO SATIN-RETT - NO LUX - NO SATIN)	0,40 ≤ f ^h ≤ 0,74
		DIN 51130 ≥ R 9 (NO SATIN-RETT - NO LUX - NO SATIN)	R10 R11
		DIN 51097 (NO SATIN-RETT - NO LUX - NO SATIN)	Classe B Classe C Class B Class C Classe B Classe C Gruppe B Gruppe C Класс B Класс C
	DCOF		f ^h ≥ 0,42



Design your life

Via A. Volta 23/25 - 42013 Casalgrande (Re) Italy
Tel. +39-0522-998911/411
Fax Italy +39-0522-998910
Fax Export +39-0522-998930/996218



CE
GRUPPO ROMANI S.P.A. INDUSTRIE CERAMICHE VIA A. VOLTA 9, 23/25 42013 CASALGRANDE (RE)
05 001CPR2013-07-01
EN 14411:2012
Piastrelle di ceramica pressate a secco, con assorbimento di acqua E _s ≤ 0,5%, per pavimentazioni interne ed esterne.
Dry pressed ceramic tile with water absorption E _s ≤ 0,5%, for internal and external floorings.

© Copyright 2021 Gruppo Romani S.p.A.

Gruppo Romani S.p.A. Industrie Ceramiche
www.grupporomanispa.com



ABSOLUTE STONE

#SIZE

100x100
40"x40"

80x80
32"x32"

60x120
24"x48"

60x60
24"x24"

30x60
12"x24"

#COLORS

MOON

GREY

BLACK

CLAY

GROUND

#SURFACES

NAT

R11

Cercom is a brand of