

PRESTIGE-ELEKTRISCH PERGOLA 3.6×4M

Montageanleitung - DE

Diese Instruktionen müssen im gesamten Verlauf des Produktlebenszyklus aufbewahrt werden. Wir raten Ihnen, diese sehr sorgfältig zu lesen, bevor Sie mit dem Aufbau beginnen. Der Verbraucher ist für jegliche Schäden oder Verletzungen, die durch inkorrekte oder unsachgemäße Installation verursacht wurden, verantwortlich.

TIPPS UND SICHERHEITSHINWEISE

Je nach Standort und Fläche kann eine Baugenehmigung für die Konstruktion nötig sein. Stellen Sie sicher, dass Sie sich vor der Montage bei Ihren örtlichen Behörden erkundigt haben, um die erforderlichen Informationen zu erhalten.

Montage des Produkts:

- Mindestens 2-3 Personen erforderlich
- Schutzfolie entfernen (dauert ca. 1 Stunde)
- Kinder nicht in die Nähe des Montagebereichs lassen
- Vorsicht vor Einklemmgefahr
- Schrauben erst festziehen, wenn das gesamte Produkt montiert ist
- Alle Montageschritte müssen sorgfältig befolgt werden
- Die Nivellierung der Struktur auf allen Seiten prüfen
- Pergola erst verankern, wenn das gesamte Produkt montiert ist

Am Produkt dürfen keine Änderungen vorgenommen werden. Vom Benutzer manipulierte Produkte sind nicht von der Garantie abgedeckt und erlöschen. Der Standort sollte sorgfältig ausgewählt werden. Es wird empfohlen, die Pergola nicht an einem regnerischen Tag, bei Wind, oder unter einem überhängenden Baum zu montieren.

Die Pergola muss auf einem ebenen Fundament montiert werden. Es wird empfohlen, sie auf einer Zementplatte oder an jedem Pfosten auf ca. 25 x 25 cm großen Betonplatten zu installieren. Bitte verankern Sie die Pergola ordnungsgemäß mit Spreizschrauben im Boden.

Wenn Sie Ihre Pergola in der Nähe Ihres Hauses oder eines Gebäudes montieren möchten, prüfen Sie bitte, ob Dachrinnen zur Wasserableitung vorhanden sind. Sollten diese Anweisungen nicht oder nur teilweise befolgt werden, erlischt die Garantie durch den Verkäufer.

WARTUNG

Regelmäßige Wartung ist notwendig, um die Langlebigkeit und das ästhetische Erscheinungsbild zu gewährleisten.

Wir empfehlen:

- Reinigen Sie Ihre Pergola ein- oder zweimal im Jahr mit frischem Wasser und einem Schwamm oder Tuch.
- Verwenden Sie keine Reinigungsmittel oder Scheuermittel.
- Überprüfen Sie regelmäßig (mindestens einmal im Jahr) den festen Sitz der Schrauben.
- Ölen Sie die Befestigung regelmäßig (mindestens einmal im Jahr).
- Stellen Sie sicher, dass nichts den Wasserfluss in den Dachrinnen behindert (Blätter, Zweige...).

GARANTIE

Dieses Produkt sollte nicht bei extremem Wetter verwendet werden: Stürme, starke Winde, Hagel und Schnee. Wir garantieren die Widerstandsfähigkeit der Pergola bei Winden bis zu 88 km/h und einem maximalen Schneelastgewicht von 70 kg/m².

Im Falle von starkem Wind oder Schnee empfehlen wir dringend, die Lamellen offen zu lassen. Um die guten Arbeitsbedingungen Ihrer Lamellen zu erhalten, räumen Sie bitte den Schnee von ihnen ab.

Unsere Pergola kann starkem Regen standhalten, aber wir können aufgrund einiger extremer Wetterbedingungen nicht garantieren, dass sie zu 100% wasserdicht ist.

Außergewöhnliche klimatische Ereignisse können die perfekte Abdichtung des Produkts beeinträchtigen. Um Schäden und Verletzungen zu vermeiden, empfehlen wir nicht, auf das Dach oder die Struktur der Pergola zu klettern.

GARANTIE

Diese Garantie deckt nicht ab:

- Normale Abnutzung und Verschleiß der Produkte.
- Verlust oder Bruch von Teilen während des Auspackens oder der Installation.
- Mangelnde Sorgfalt, Vernachlässigung, Vandalismus, Aufprall auf Fremdkörper, Gewalt, Kontakt mit abrasivem Material, Produktästhetik, Demontage, Wiederaufbau oder Standortwechsel.
- Höhere Gewalt: Hagel, starker Wind, Sturm, Schnee, Überschwemmung, Blitzeinschlag usw.
- Manipulationen am Produkt durch den Benutzer.

Die Garantie umfasst nur den Ersatz von Ersatzteilen oder des gelieferten Produkts, eine Rückerstattung erfolgt nicht.

Alle Garantieansprüche müssen bei der Verkaufsstelle (Geschäft oder Website) geltend gemacht werden, bei der das Produkt gekauft wurde.

LISTE DER TEILE (PRO KARTON)

Bevor Sie mit der Montage Ihrer Lamellen Pergola fortfahren, müssen Sie überprüfen, ob alle aufgeführten Teile enthalten und unbeschädigt sind. Fehlende Teile müssen innerhalb von 10 Tagen nach der Lieferung gemeldet werden.

Sie können entweder über Ihren örtlichen Outlet-Store gehen oder die Anfrage direkt auf unserer Website stellen.

Werfen Sie die Verpackung nicht weg, ohne sicherzustellen, dass das Produkt ordnungsgemäß funktioniert.

Notwendiges Werkzeug und Sicherheitsausrüstung (nicht beiliegend)

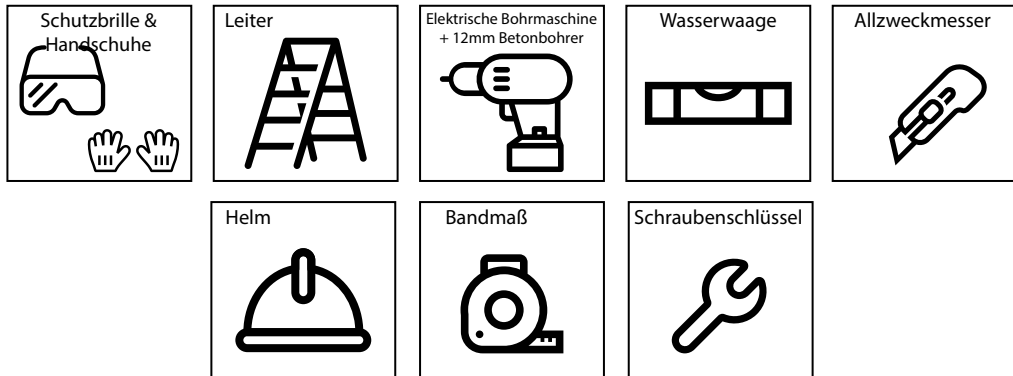

2D Fundamentmessung (Dimensionen in mm)

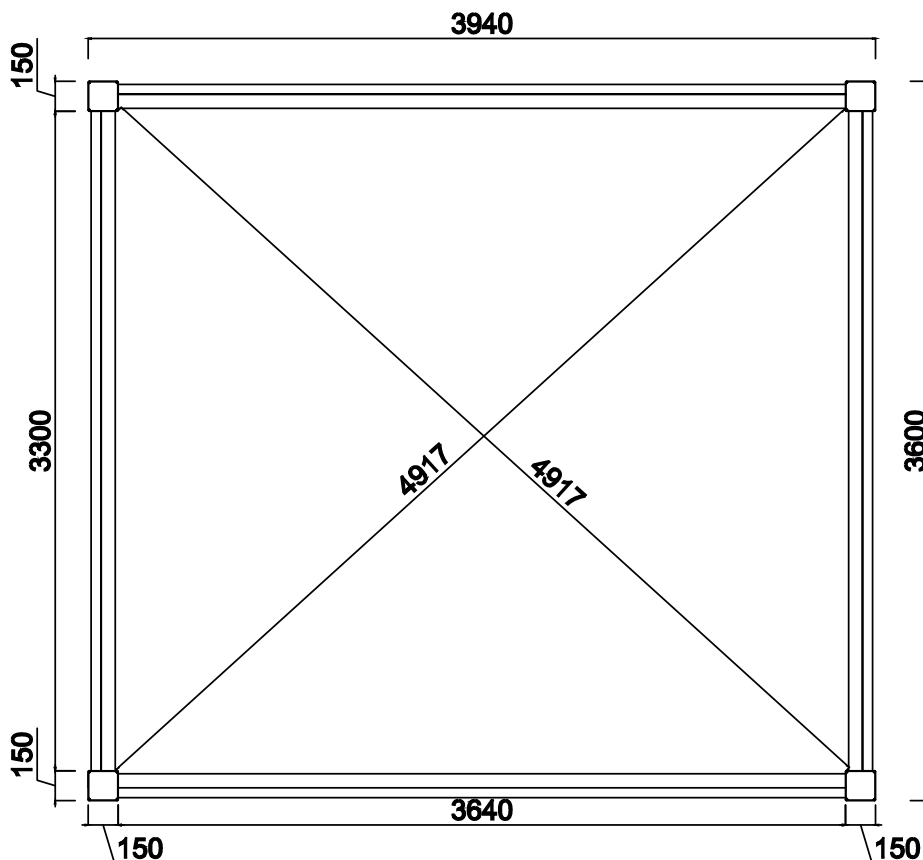

2D Fundamentmessung (Dimensionen in mm)

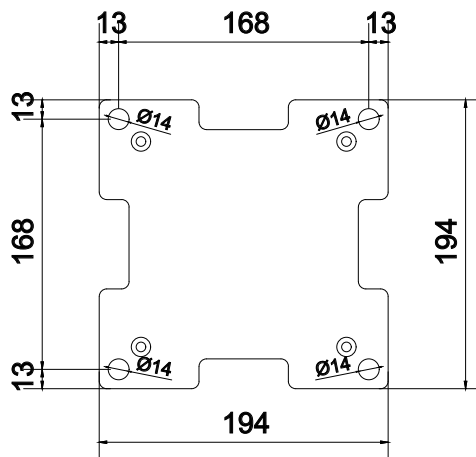
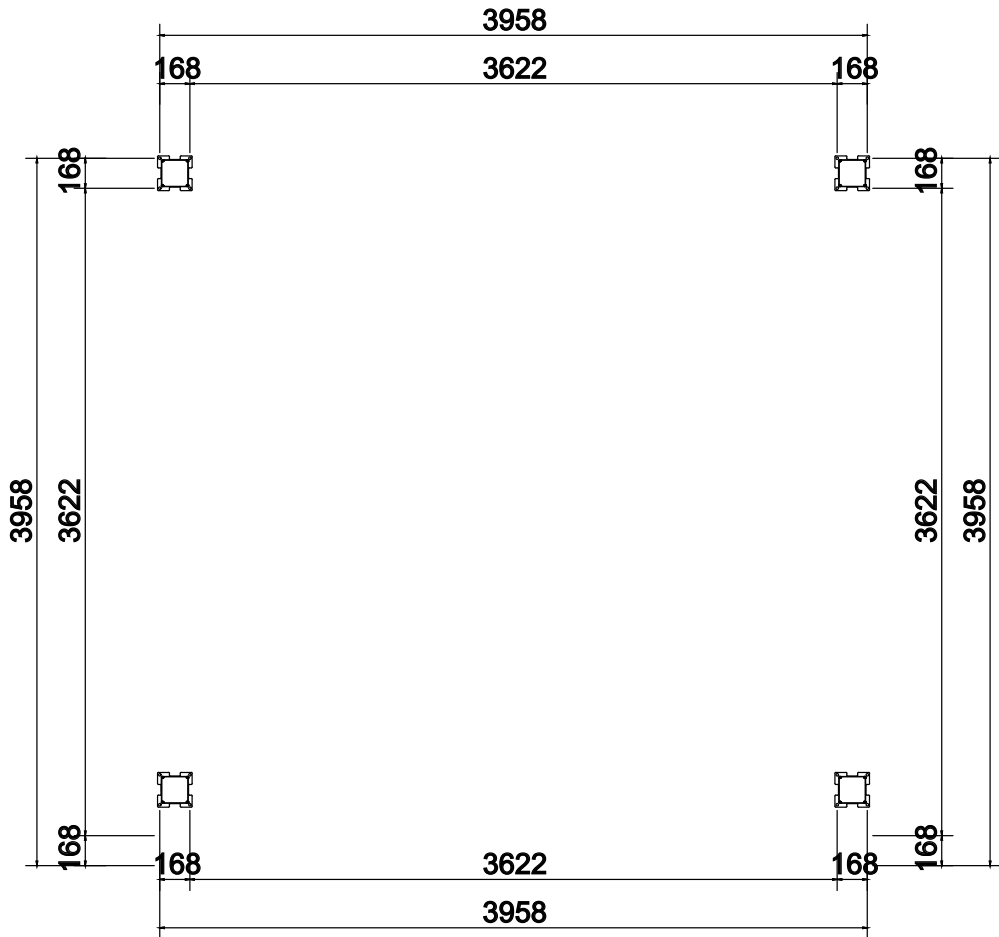



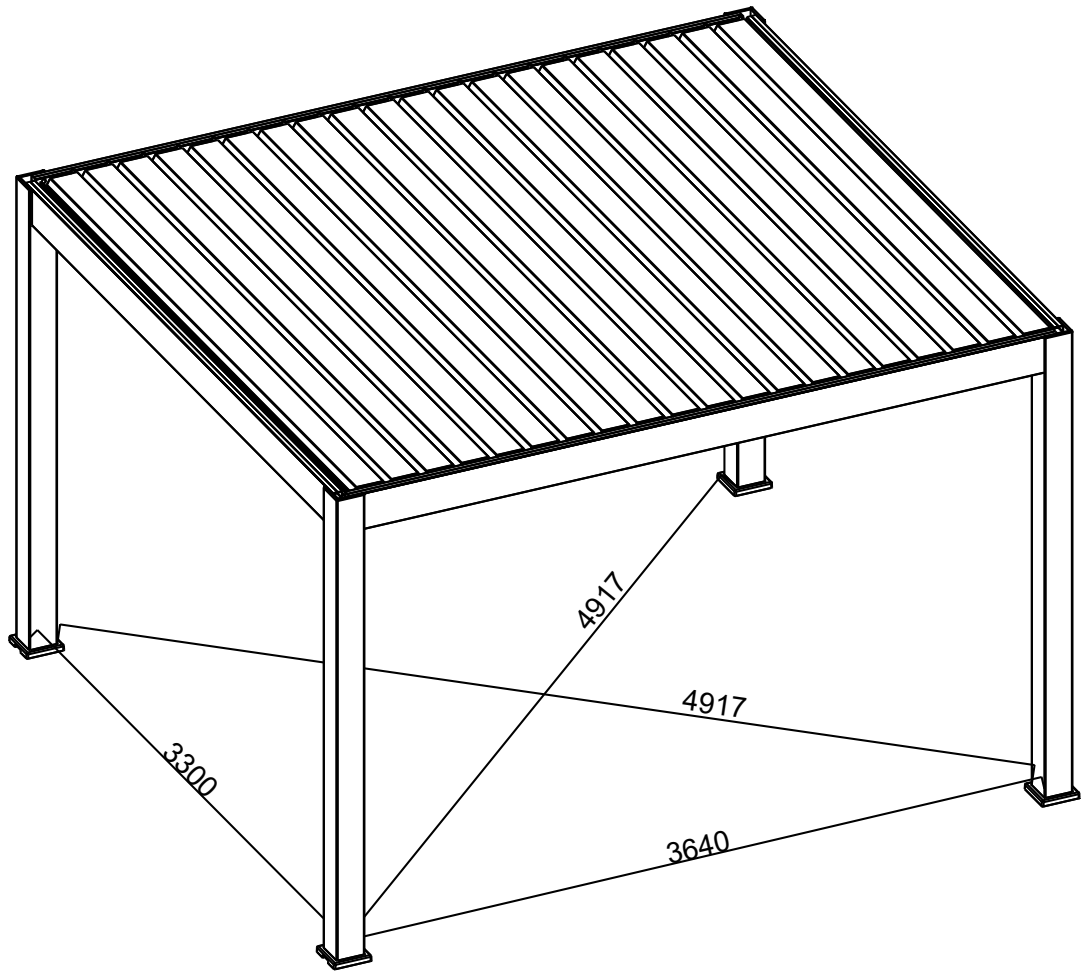









3D Fundamentmessung (Dimensionen in mm)

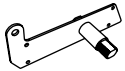

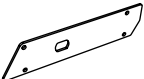











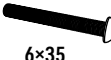

LISTE DER TEILE (PRO KARTON)

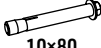

KARTON 1/5 (PFOSTEN UND LOSE TEILE)

REF	BILD	MENGE
A		4

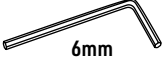
REF	BILD	MENGE
N1		4
N2		4
N3	  6mm	16
N4		16
N5		1
N6		19
N7		20
N8		39
N9		40
N10		40
N11		39
N12		39
N13	 Kontermutter	20

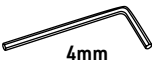





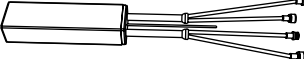
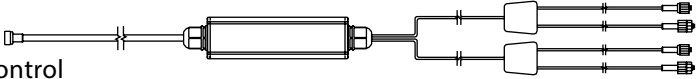

REF	BILD	MENGE
N14	 Kunststoffmutter	20
N15		40
N16	  6x20 4mm	20
N18	  6x35 4mm	16
N19	  5x60 PH2	32
N20	 10x80	16
N21		4
N22	  4x16 PH2	160

REF	BILD	MENGE
Z1	 6mm	1
Z2	 6mm	1
Z3	 4mm	1

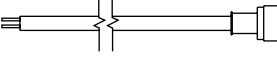



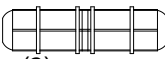

REF	BILD	MENGE
Z4	 4mm	1
Z5	 10mm	1
Z6	 PH2	1

KARTON 1/5 (PFOSTEN UND LOSE TEILE)

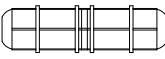
Elektrische Produkte

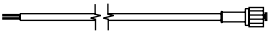

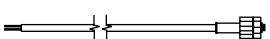
REF	BILD	MENGE
E-C	Controller 	1
E-L	LED control 	1
E-R	Fernbedienung 	1
E-P	Stromkabel (M15)  	1
E-W2	Wasserdichte Verbindung (2)  	1
E-W3	Wasserdichte Verbindung (3)  	1

LED-Kabel

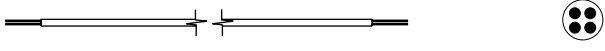
REF	BILD	MENGE
E-W4	Wasserdichte Verbindung (4)  	5
L-C1	 	4
L-C2	 	4

REF	BILD	MENGE
L-CL		1

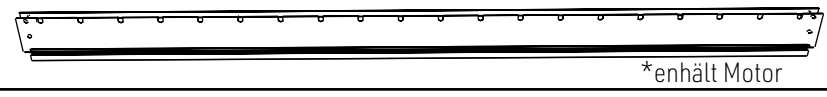
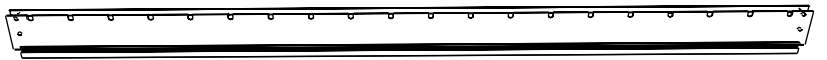
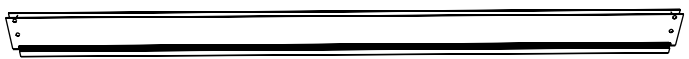
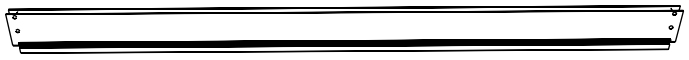
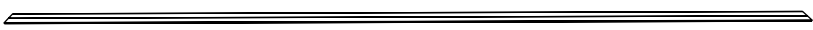
KARTON 2/5 (PFOSTEN UND LOSE TEILE)

REF	BILD	MENGE
B-1	 *enthält Motor	1
B-2		1
B-3		1
B-4		1
D-1		2
D-2		2
F-1		1



VORSICHT!

Verbindungsstange (FO) und Bürste innen!

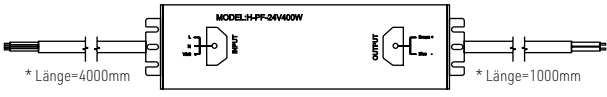

REF	BILD	MENGE
E-T	 <p style="text-align: center;">Transformator</p>	1



KARTON 3/5 & 4/5(PFOSTEN UND LOSE TEILE)

REF	BILD	MENGE
G1		7

KARTON 5/5 (PFOSTEN UND LOSE TEILE)

REF	BILD	MENGE
G1		3
G2		3

Schritt 1

REF	BILD	MENGE
N1		4
N2		4

REF	BILD	MENGE
A		4

Electrisch

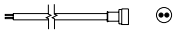
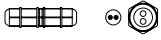
REF	BILD	MENGE
E-P		1
E-W2		1

REF	BILD	MENGE
E-T		1

1.1
Bitte verbinden Sie das Ausgangskabel (E-T) mit dem Stromkabel (E-P) des Transformators unter Verwendung der wasserdichten Verbindungen (E-W2).

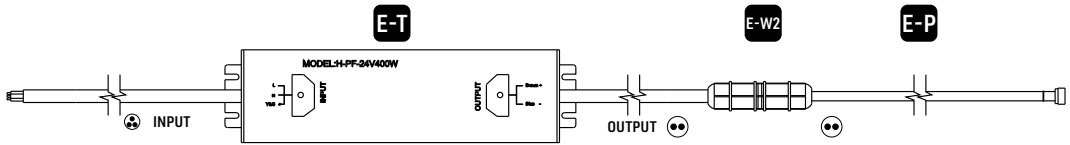

1.2
Bitte setzen Sie die Eingangsleitung des Transformators in die Vertiefung des Pfostens ein. Ziehen Sie die Eingangsleitung durch die Entwässerungsöffnung des Pfostens. Installieren Sie die Platte und die Abdeckkappe des Pfostens nach dem Herausziehen der Eingangsleitung.

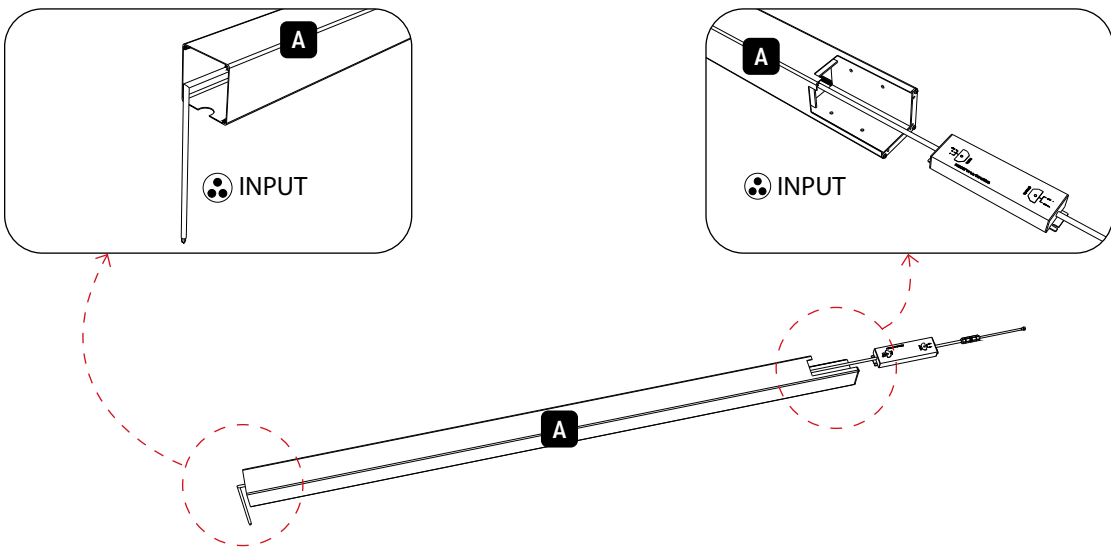

Schritt 1

1.3

Setzen Sie die Abdeckkappe (N1) auf den Pfosten (A). Bitte beachten Sie, dass die Kerbe an der Abdeckkappe und die Entwässerungsöffnung des Pfostens gemäß dem untenstehenden Diagramm ausgerichtet sein sollten.

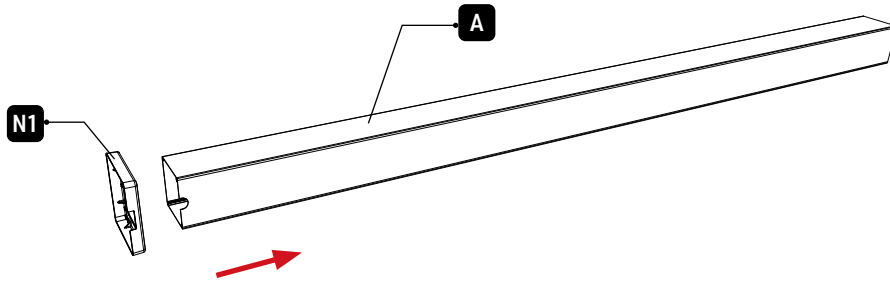

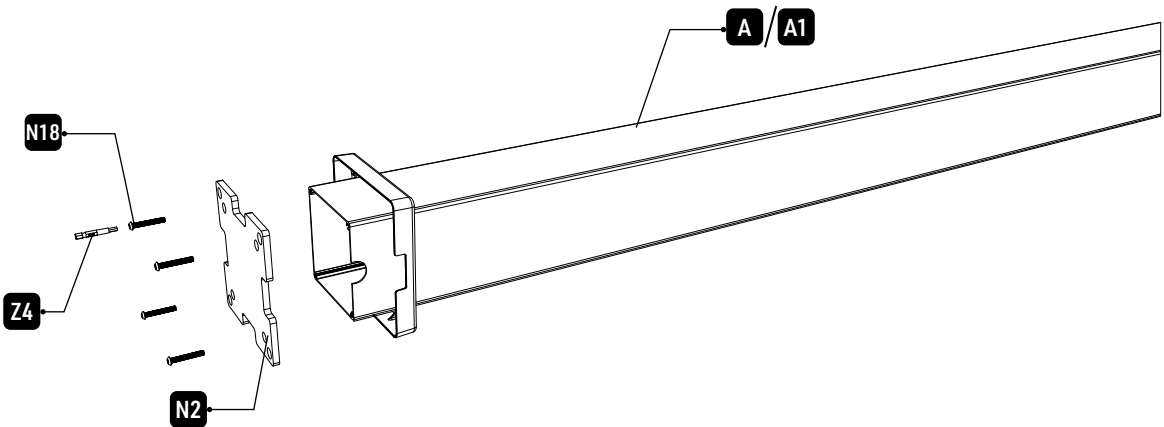

Installieren Sie die Platte.

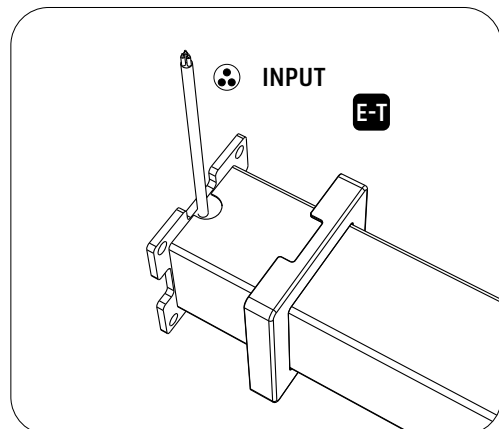
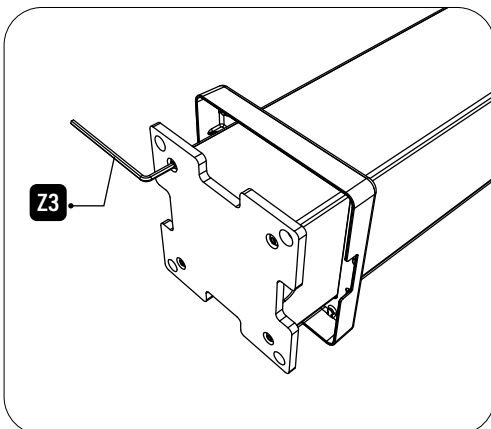

Verwenden Sie den Pistolendrill, um Schrauben auf der Platte zu befestigen, und ziehen Sie dann die Schrauben mit dem Schraubenschlüssel fest.



Schritt 2

REF	BILD	MENGE
N3	  6mm	8

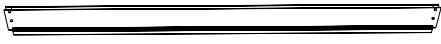
REF	BILD	MENGE
B-3		1
B-4		1

2.1

Setzen Sie den Transformator in die Vertiefung von B-3 ein und achten Sie darauf, genügend Länge des Stromkabels (E-P) zu reservieren.

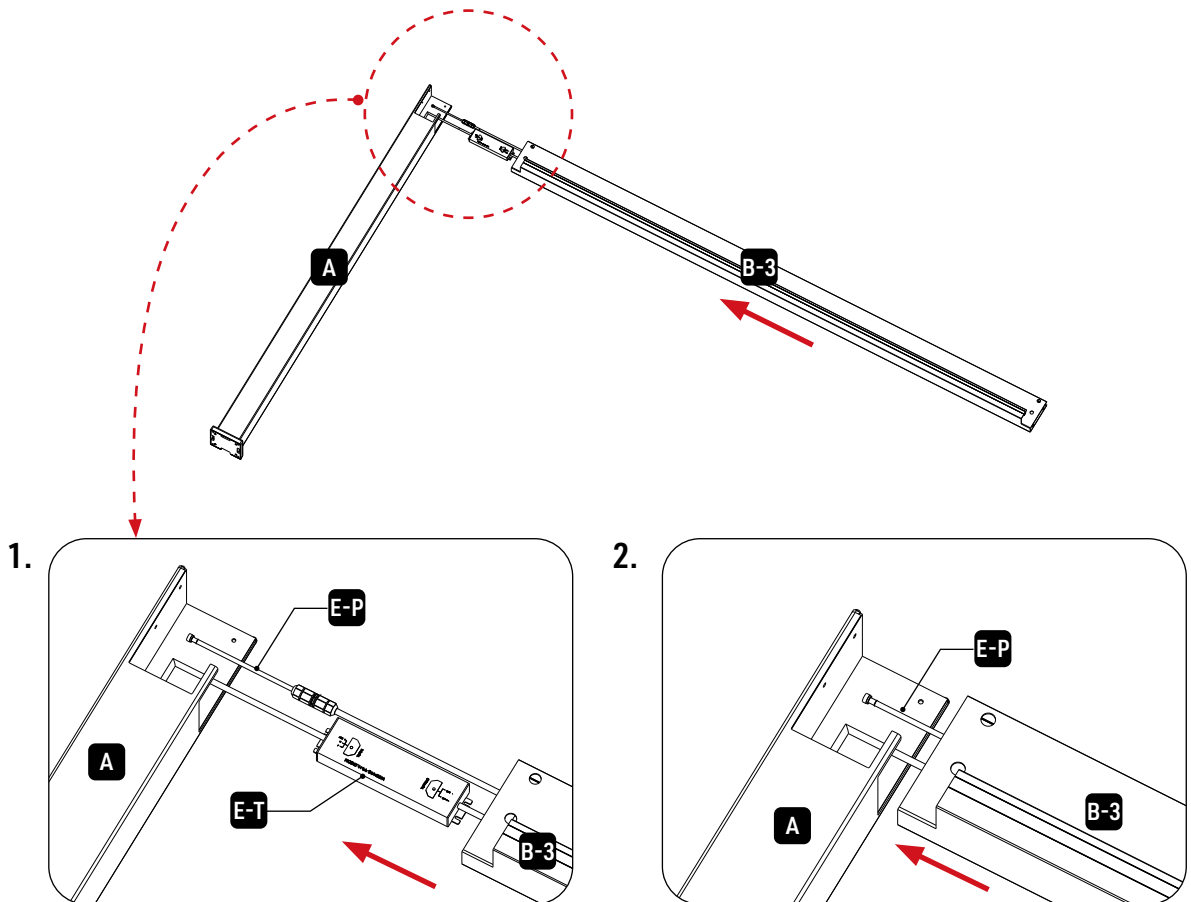

Schritt 2

2.2

Verbinden Sie den Träger (B-3) mit dem Pfosten (A) gemäß dem untenstehenden Diagramm. Bitte denken Sie daran, das Stromkabel (E-P) außerhalb des Trägers zu halten.

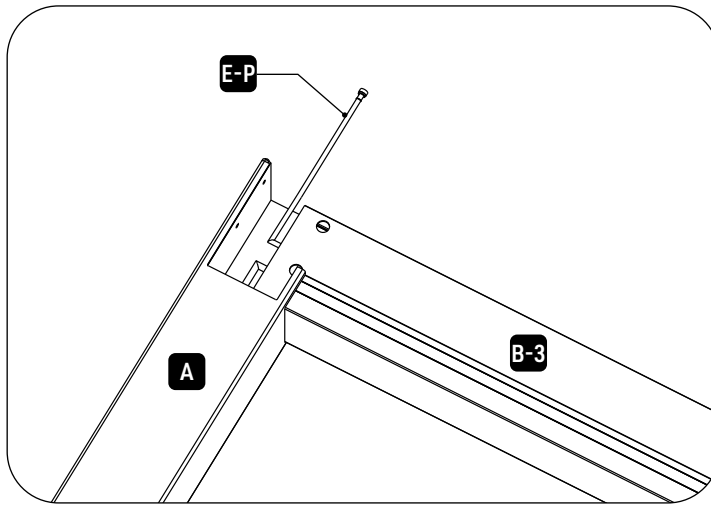

2.3

Verwenden Sie den Pistolendrill, um Schrauben am Pfosten zu befestigen, und ziehen Sie dann die Schrauben mit dem Schraubenschlüssel fest.

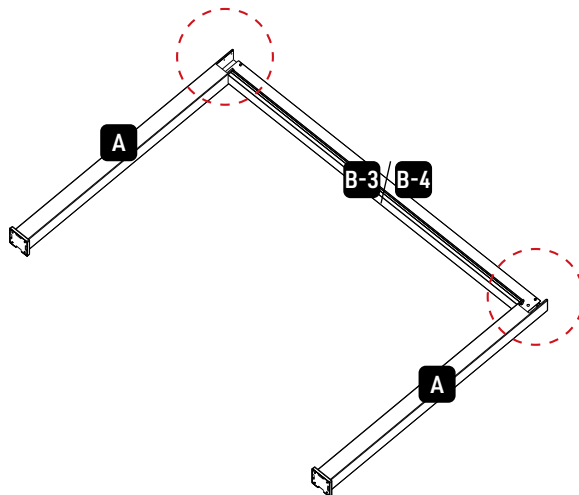



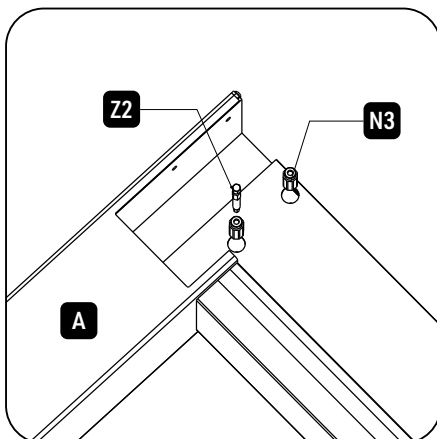

1.

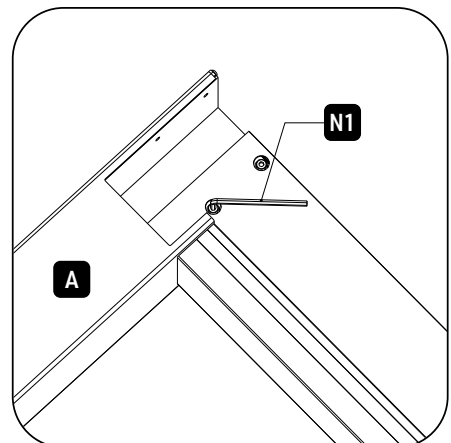

2.



Schritt 3







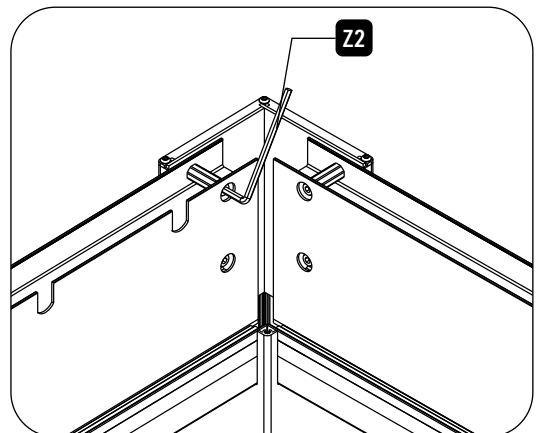
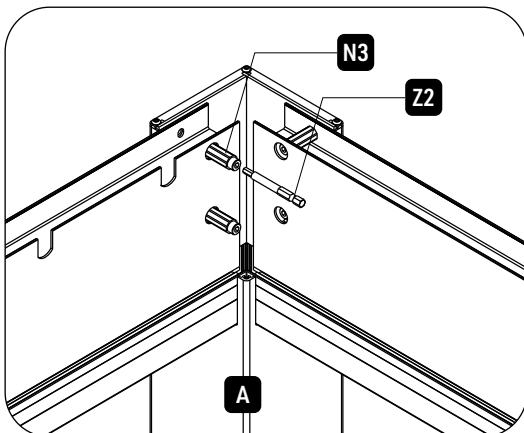
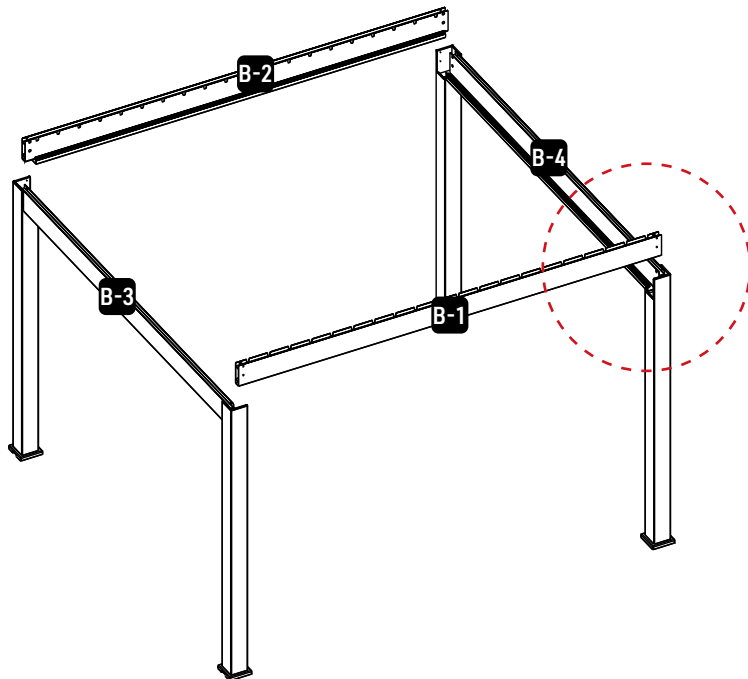

REF	BILD	MENGE	REF	BILD	MENGE
N3		24	B-1	 *Motor inside	1
			B-2		1
			B-3		1
			B-4		1

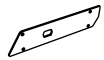

3.1

Verbinden Sie die Balken mit den Pfosten



Schritt 4

REF	BILD	MENGE
N5		1
N6		19
N7		20
N8		39
N9		40
N10		39
N11		39
N12		39

REF	BILD	MENGE
G1		17
G2		3

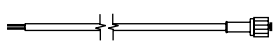
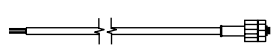
REF	BILD	MENGE
L-L1		3
L-L2		3

4.1

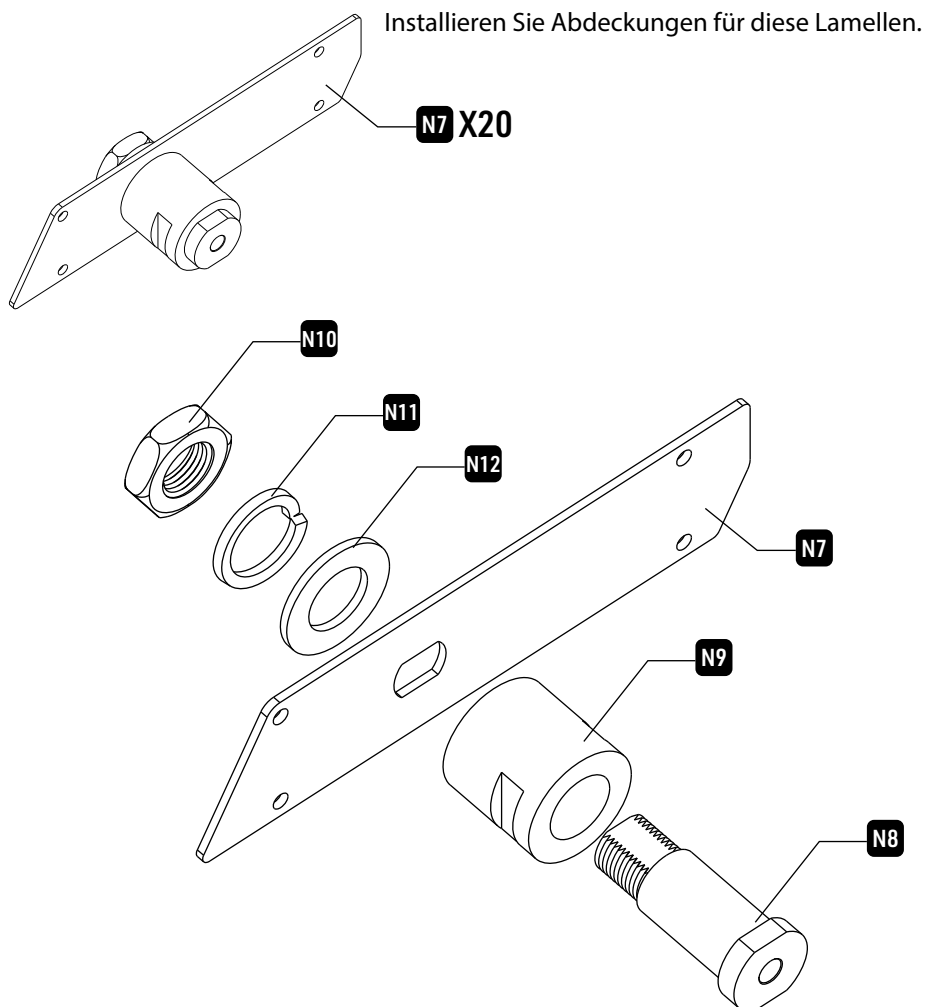

Schritt 4

4.1

Installieren Sie die Abdeckung für die Lamellen gemäß dem untenstehenden Diagramm.

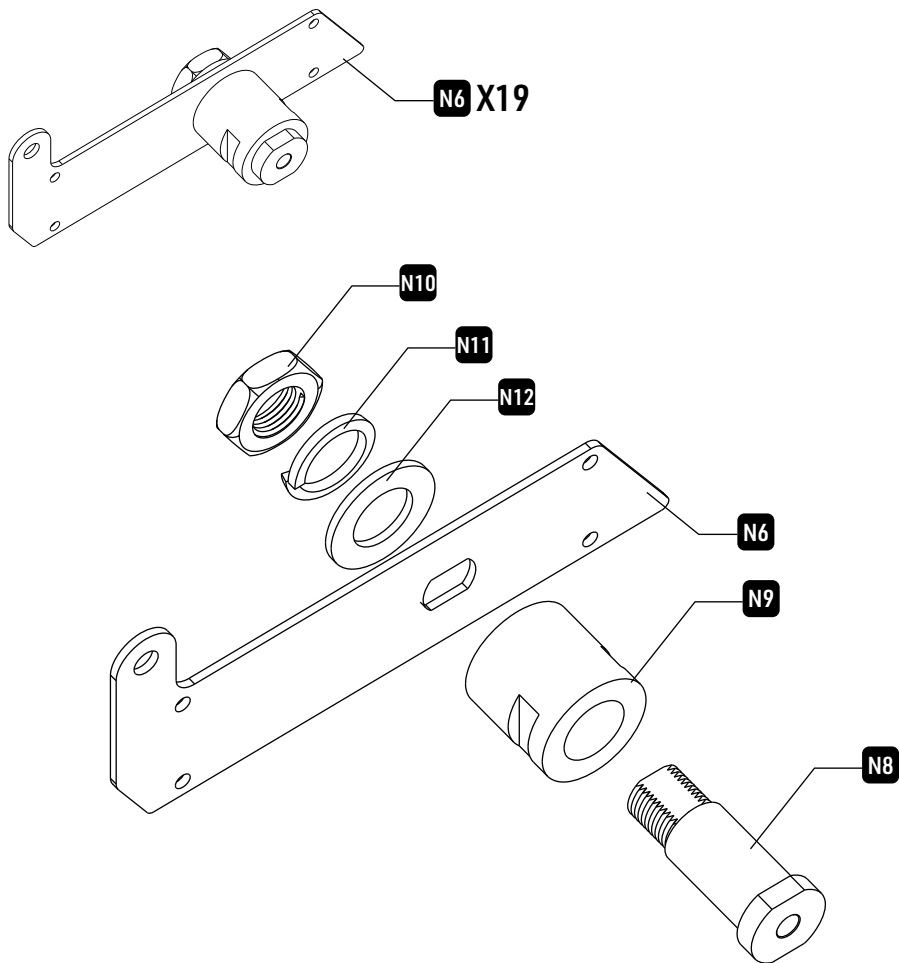

Bitte achten Sie darauf, die Abdeckung für die Hauptlamelle zu unterscheiden und die Mutter gemäß dem untenstehenden Diagramm zu installieren.

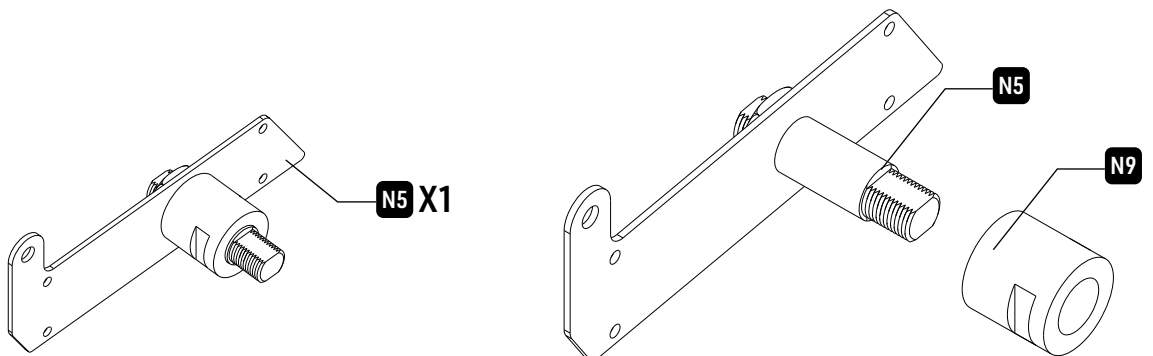

Schritt 4

4.2

Installieren Sie die Abdeckung für die Hauptlamelle.

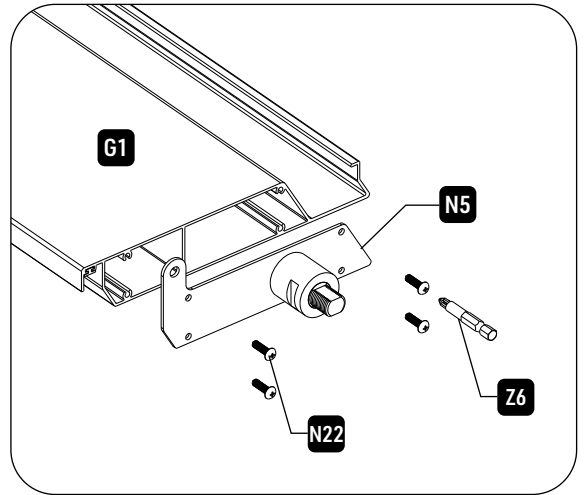
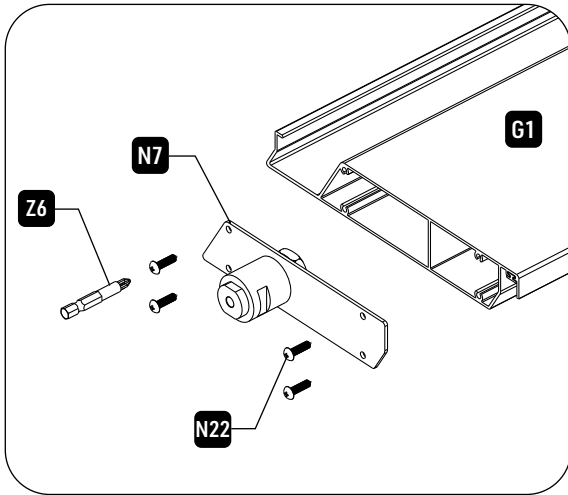
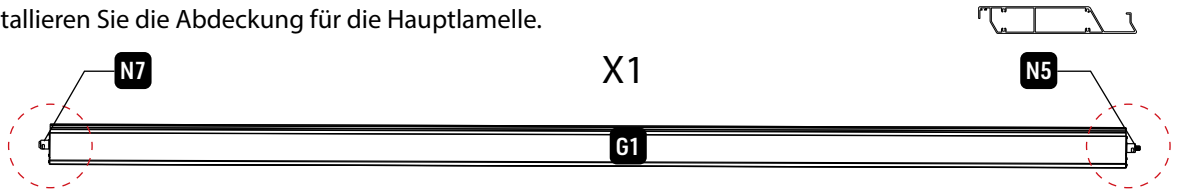

Installieren Sie die Abdeckung für die anderen Lamellen.

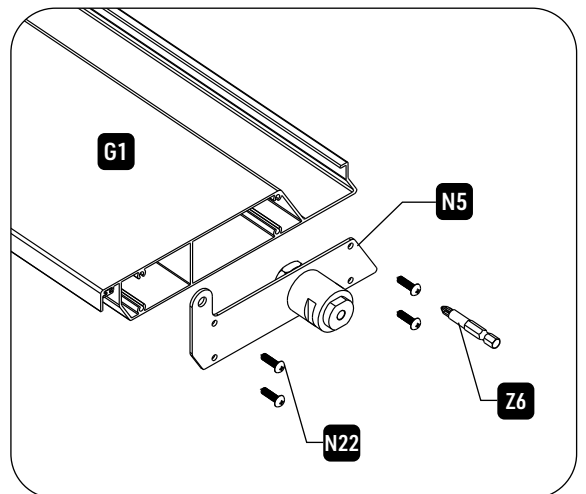
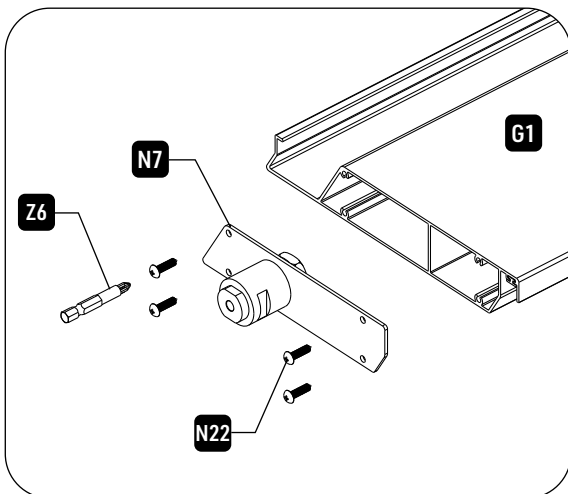
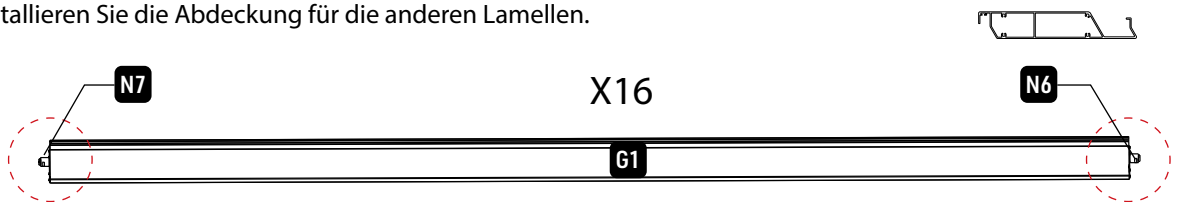

Schritt 4

4.3

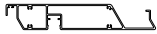





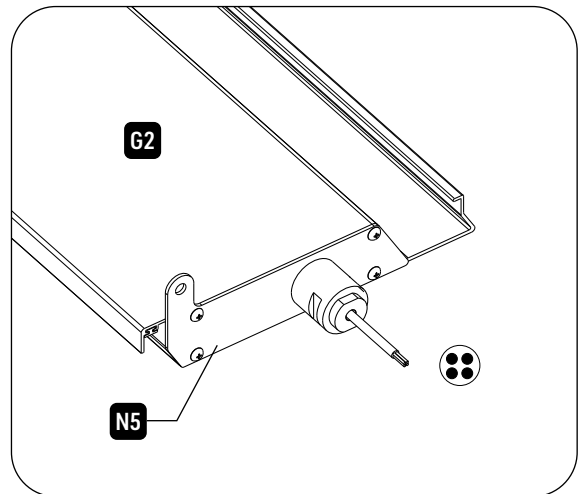
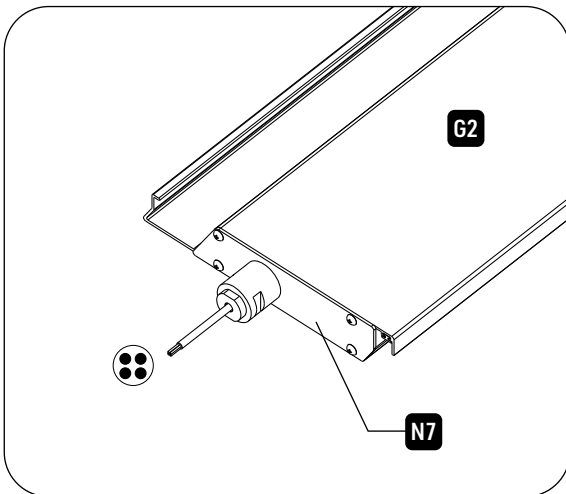
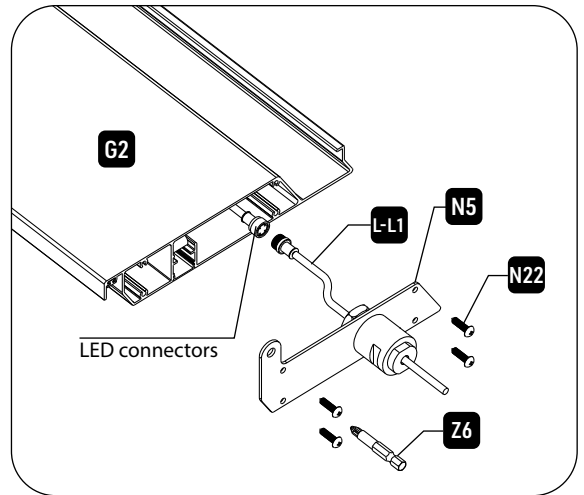
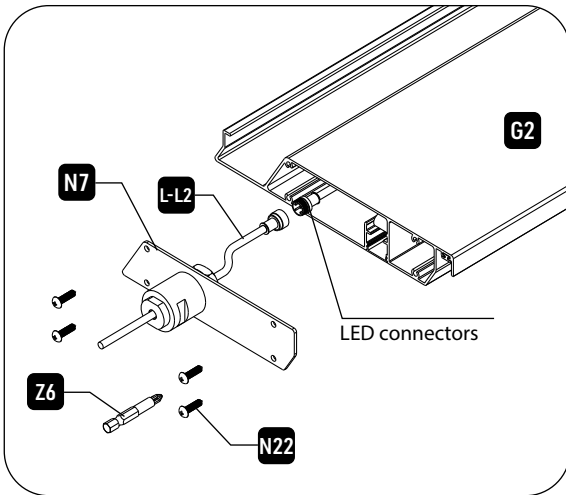
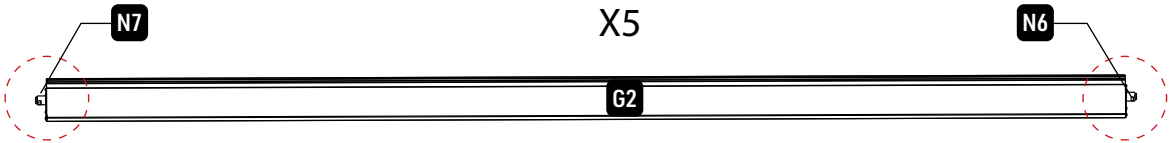

Installieren Sie das Lamellen mit LED-Connectors.

- Bitte finden Sie zuerst die Lamellen mit dem LED-Band.
- Verbinden Sie L-L1 auf der Lamellenabdeckung mit den LED-Connectors an einem Ende der Lamelle und verbinden Sie dann L-L2 mit den LED-Connectors am anderen Ende.
- Beachten Sie bitte, dass das Ende von L-L1 & L-L2 durch die Mutter der Lamellenabdeckung geführt werden sollte und die Enden außen bleiben sollten, wie im untenstehenden Diagramm gezeigt.

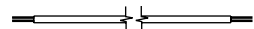

Schritt 5

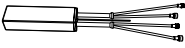
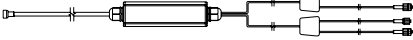
REF	BILD	MENGE
L-L1		1
L-L2		1
L-CL		1
E-W4	 	2

REF	BILD	MENGE
E-C		1
L-C2		1
E-R		1

5.1

Platzieren Sie die Hauptlamelle (G1) gemäß dem untenstehenden Diagramm und verbinden Sie dann die Hauptspindel (N5) mit dem Schwenkarm des Motors und befestigen Sie sie mit der Mutter (N10).

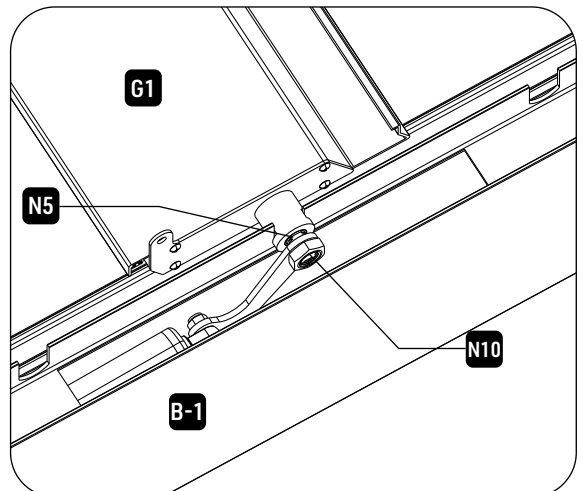
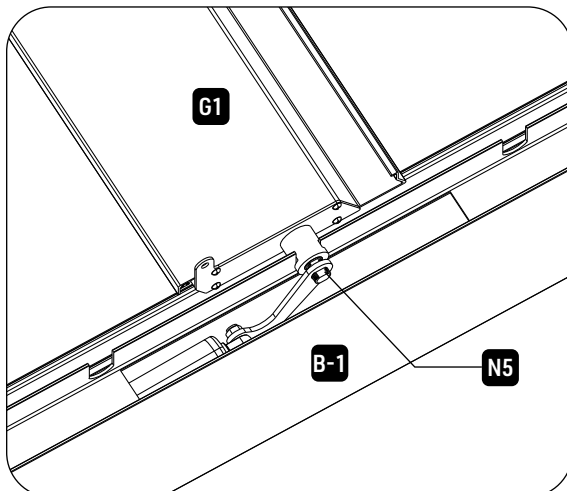
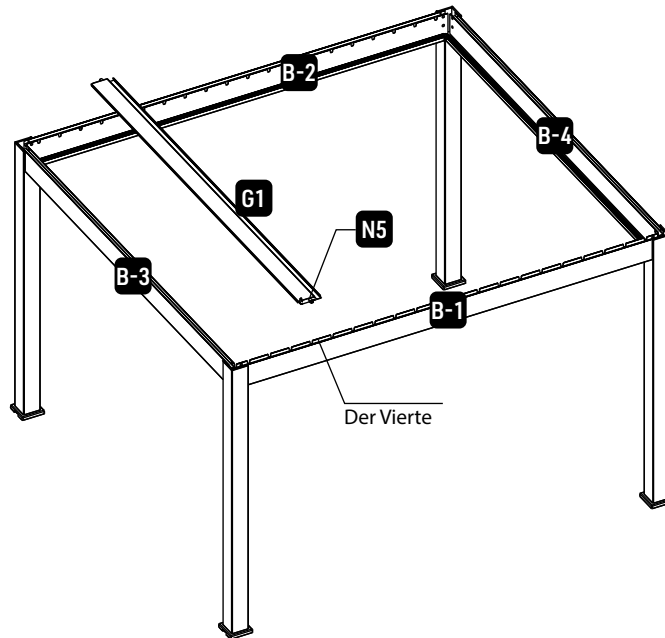

Schritt 5

5.2

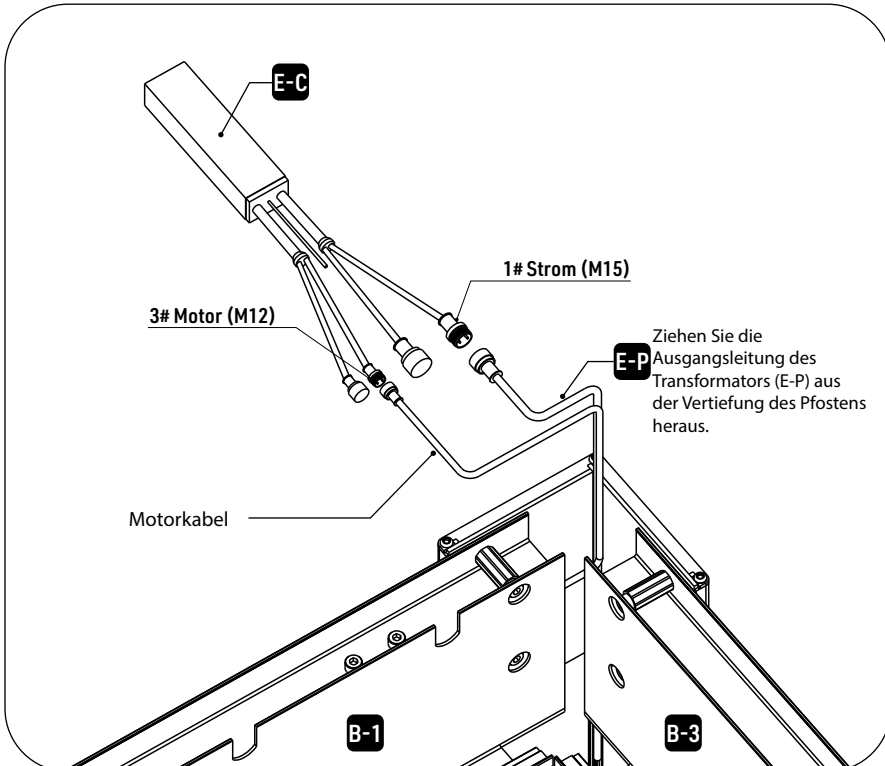
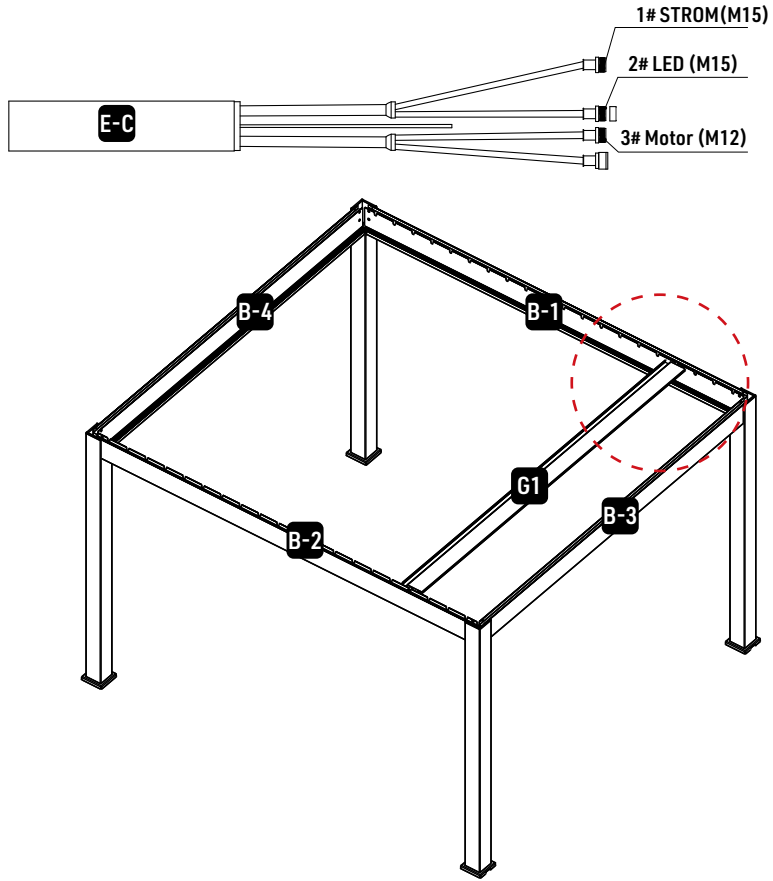

Schritt 5

5.3

Verbinden Sie das Eingangskabel des Transformators mit dem Verlängerungskabel (nicht im Lieferumfang enthalten) und stecken Sie dann den Stecker in die Steckdose.

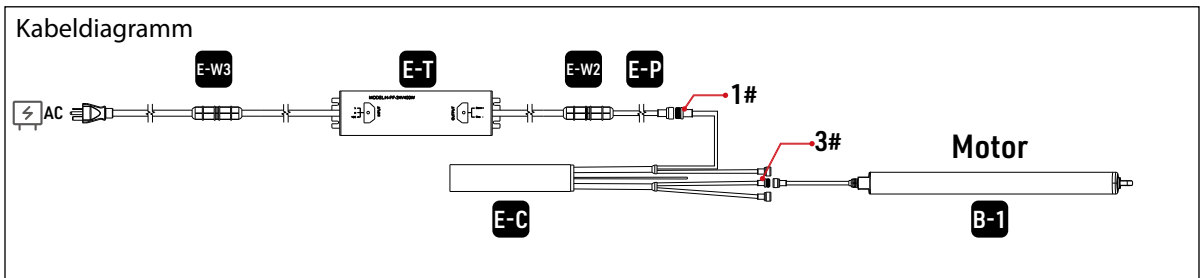
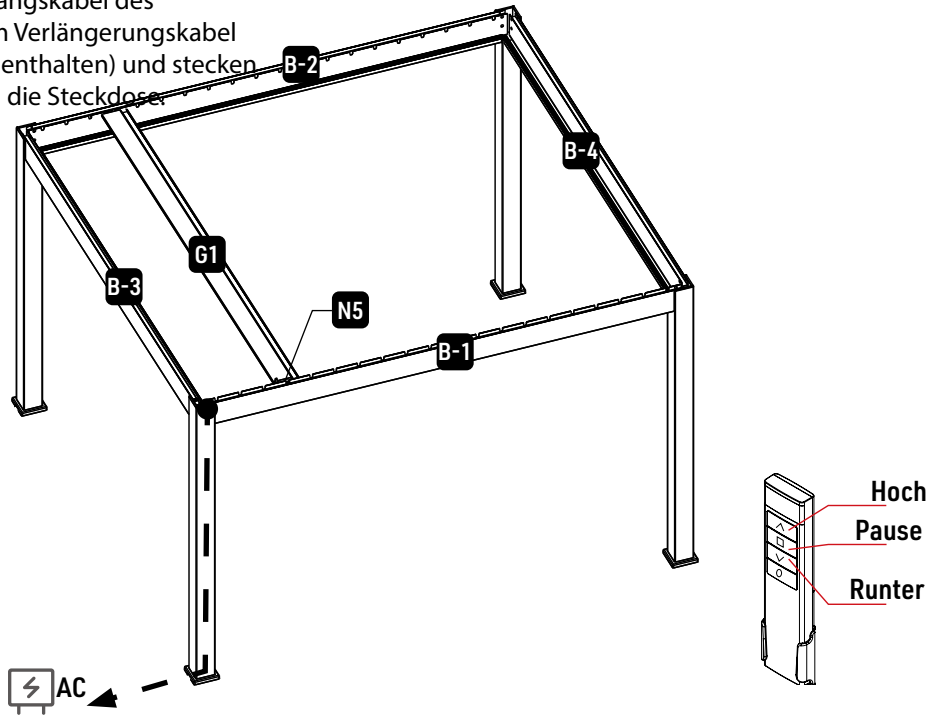

Bitte koppeln Sie den Controller gemäß dem untenstehenden Diagramm und den folgenden Schritten mit der Fernbedienung:

- 1. Drücken Sie die HOCH-Taste auf der Fernbedienung und halten Sie diese Taste 3-5 Sekunden lang gedrückt, bis die Anzeige durchgehend leuchtet.
- 2. Schließen Sie die Stromversorgung an, während Sie die AUF-Taste gedrückt halten. Wenn eine leichte Vibration am Hauptlamellen erscheint, bedeutet dies, dass die Fernbedienung und der Motor gekoppelt sind.

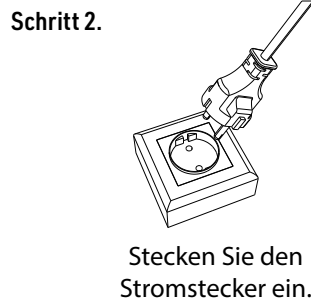
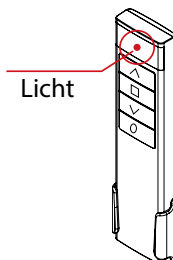

Schritt 5

5.4

Nach Abschluss des Pairings verwenden Sie bitte die Fernbedienung, um die Drehung der Lamelle zu testen, und drehen Sie dann die Lamelle in die horizontale Position.

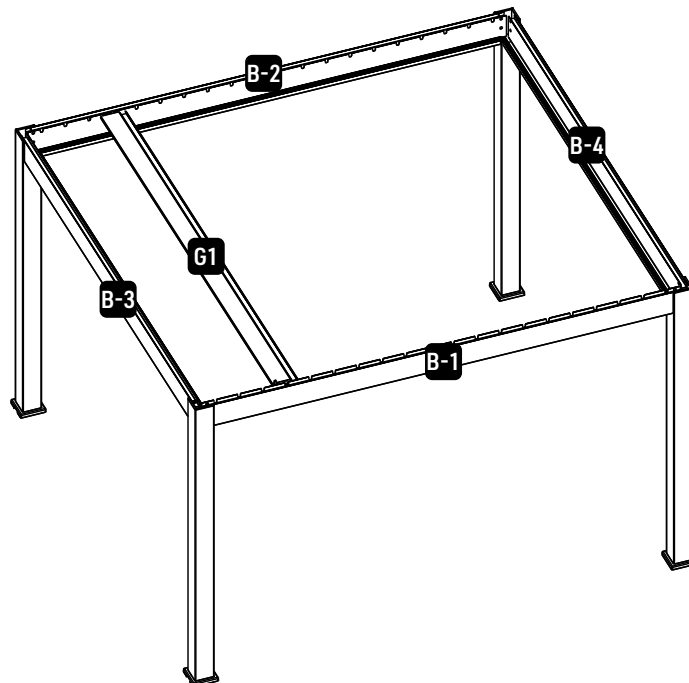
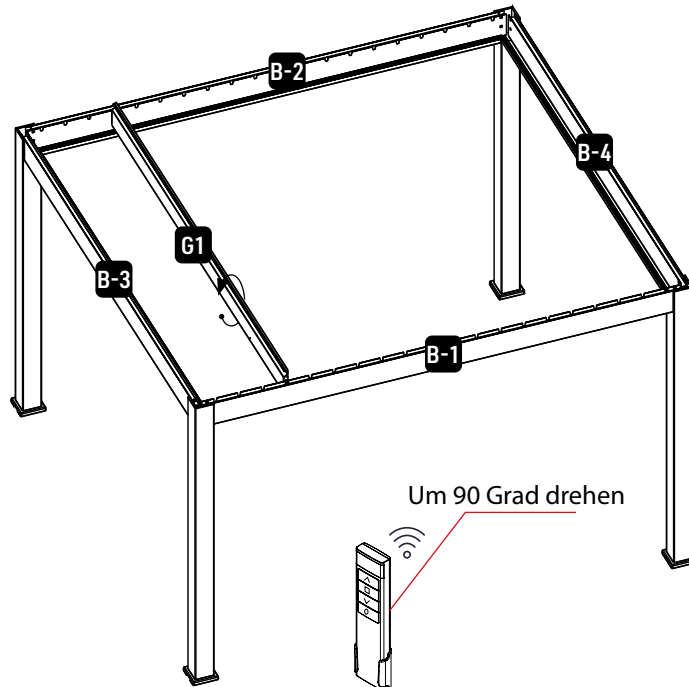

Schritt 5

5.5

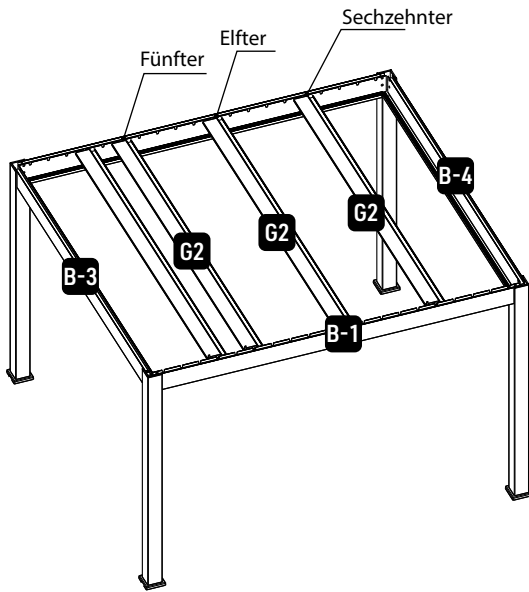

Platzieren Sie diese LED-Lamellen entsprechend der unten dargestellten Position.

Bitte beziehen Sie sich auf das untenstehende Diagramm, um das Kabelende außerhalb der Lamellenabdeckung mit dem wasserdichten Anschluss (EW-4) zu verbinden.

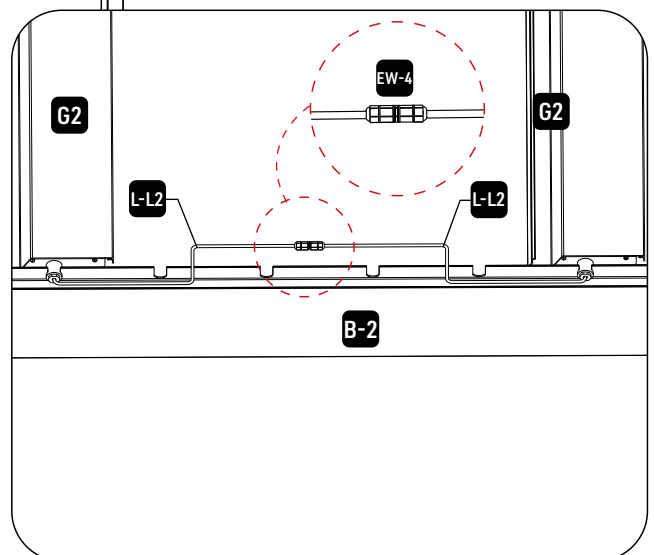
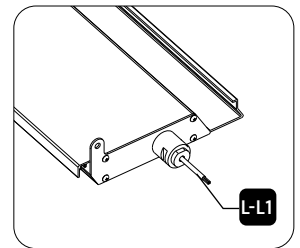
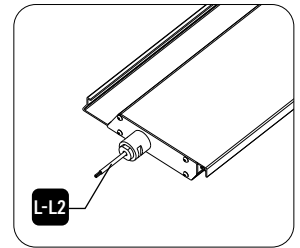
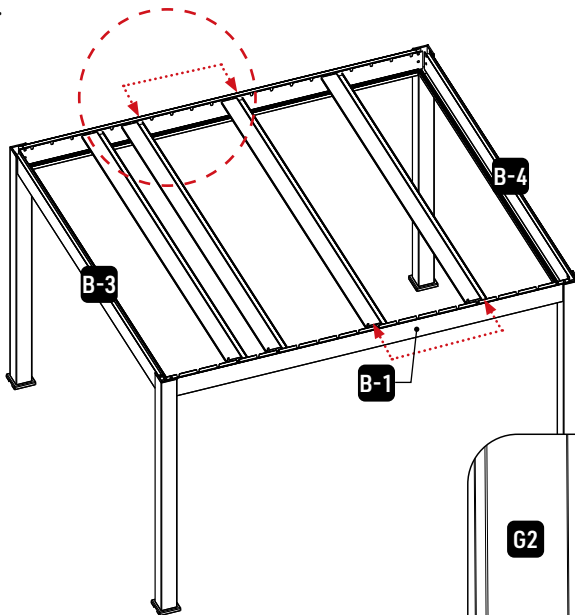

Schritt 5

5.6

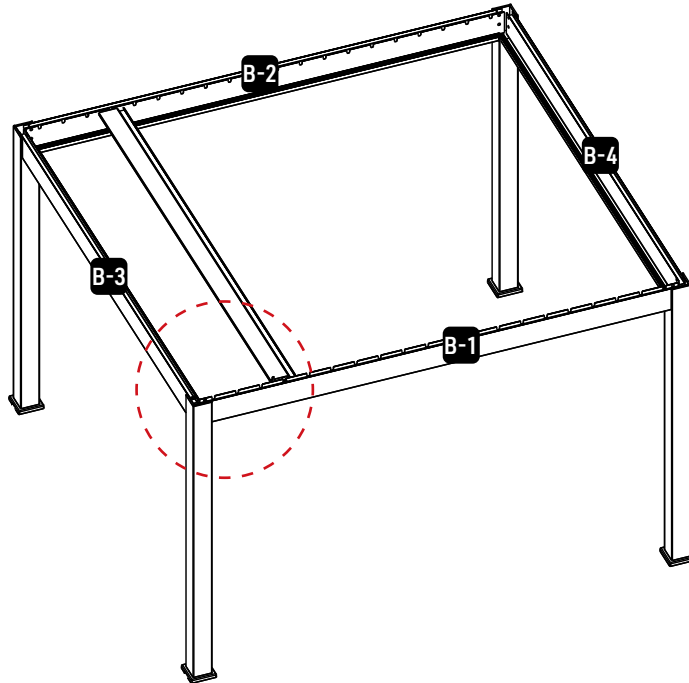
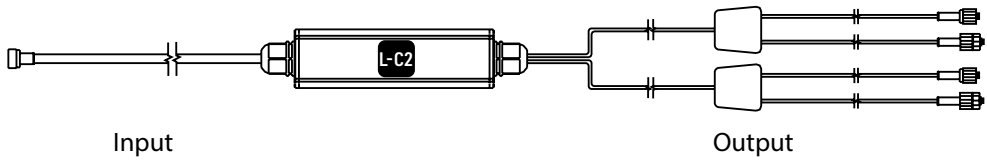

Platzieren Sie den LED-Controller gemäß dem untenstehenden Diagramm in die Vertiefung des Pfostens.

Verbinden Sie das Eingangsende von L-C2 mit der Nummer 2# des Controllers (E-C).

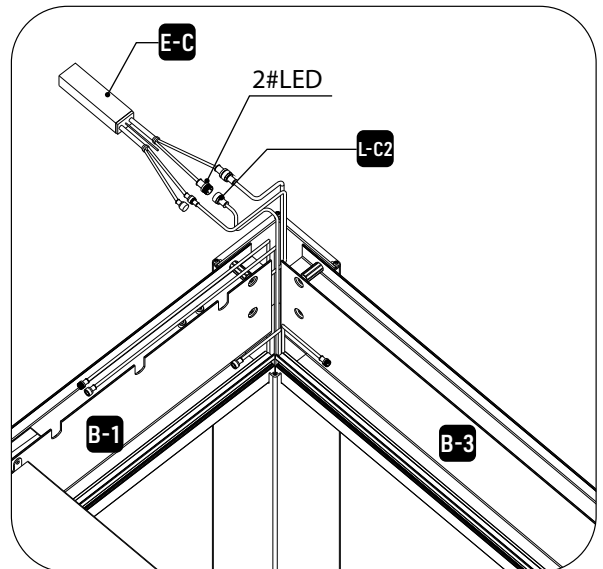
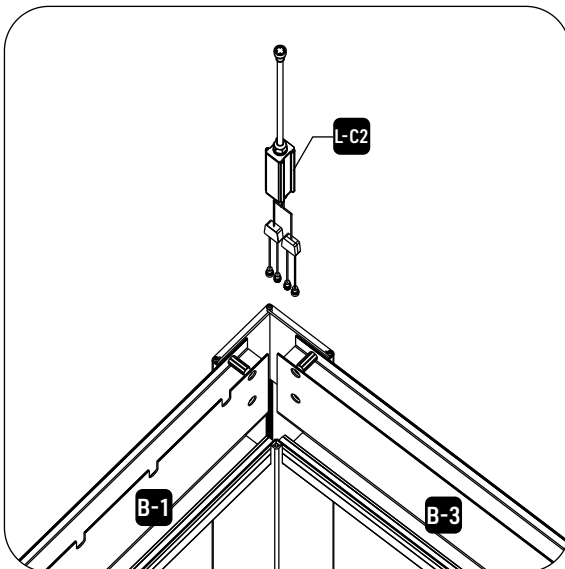

Schritt 5

5.6

Für das Ausgangsende des LED-Controllers legen Sie ein Kabel auf den Balken und ziehen Sie das andere Kabel aus der Kerbe des Balkens heraus.

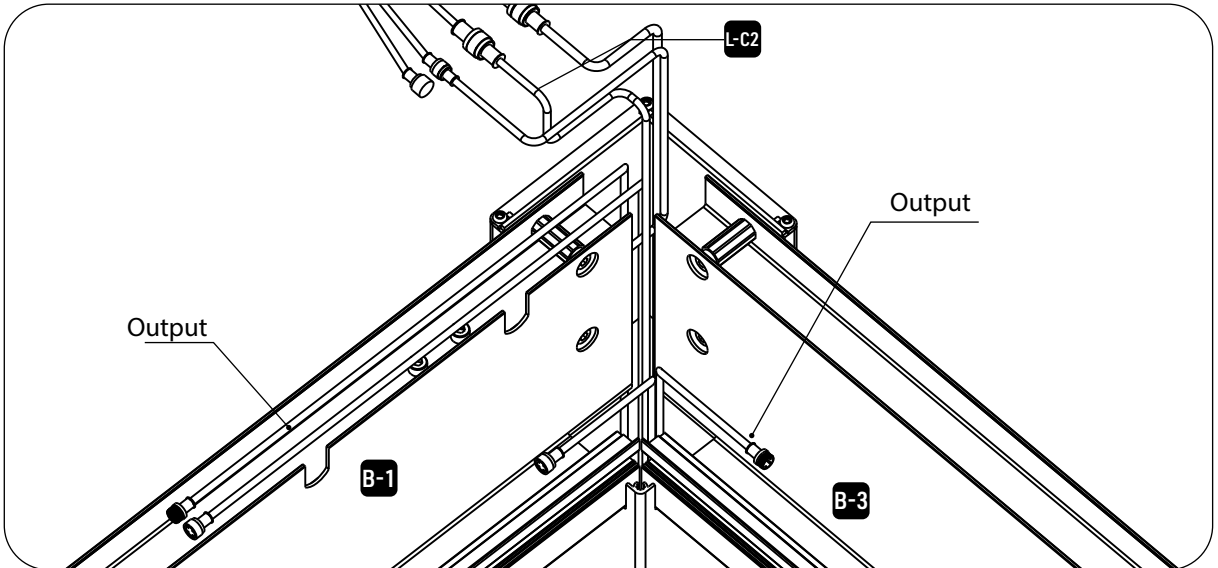

- Bitte verbinden Sie ein Ende des L-L2 (auf der Abdeckung der 16. Lamelle) mit der Verlängerungsleitung des L-CL unter Verwendung des EW-4. Führen Sie dann dieselbe Verbindung für das andere Ende des L-L2 wie im Diagramm gezeigt durch.
- Die 5. Lamelle sollte nahe am Balken von B-1 sein; verbinden Sie dann das Kabel außerhalb der Lamellenabdeckung mit dem L-L1.

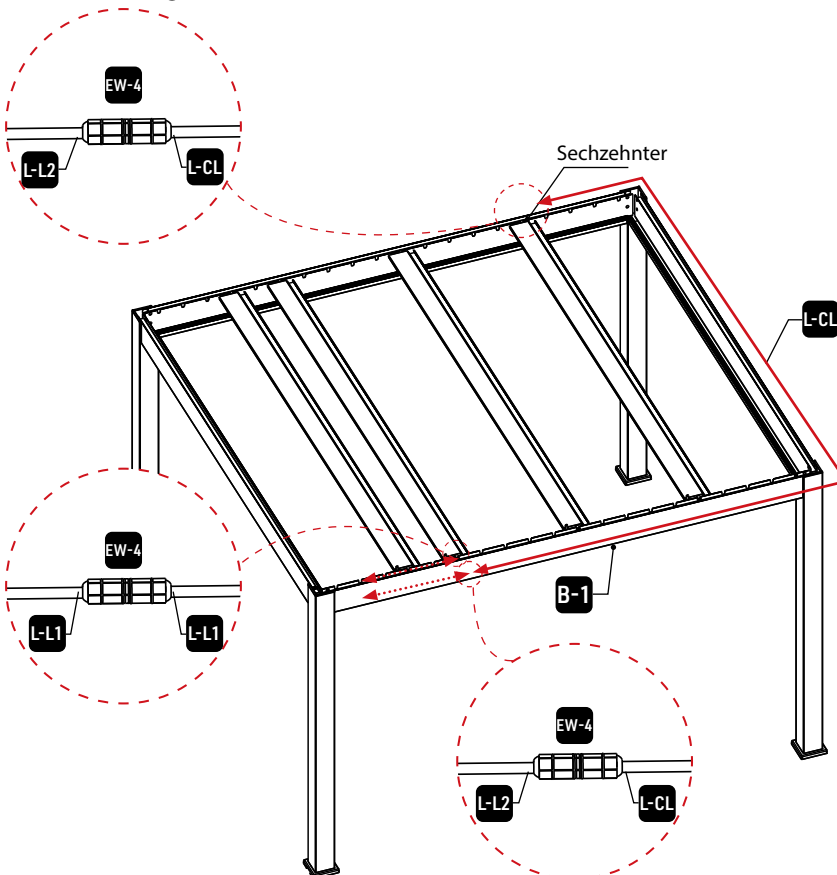

Schritt 5

5.7

Verbinden Sie das Ausgangsende des LED-Controllers mit dem Band.

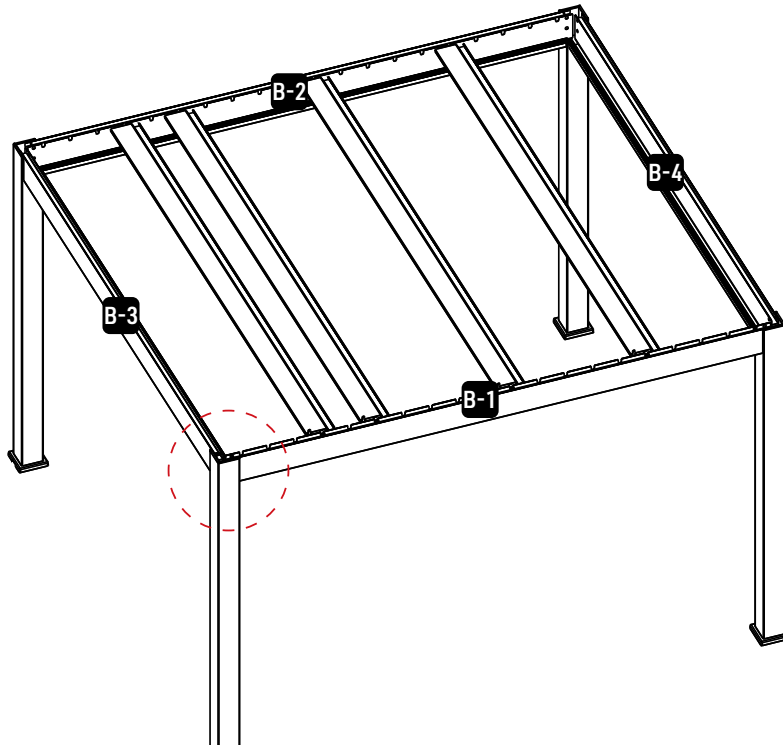

Bitte beziehen Sie sich auf das untenstehende Diagramm, um die Verbindung vorzunehmen.

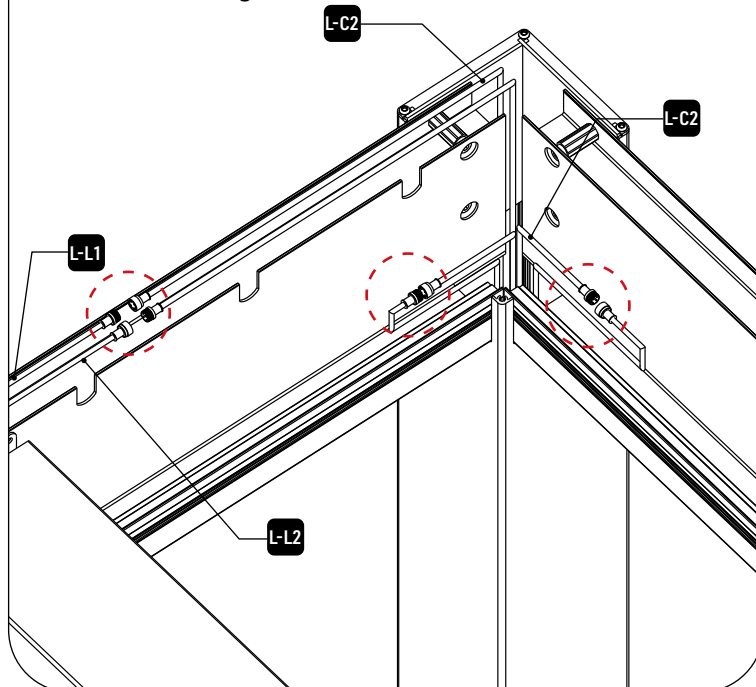

Schritt 5

5.8

Verbinden Sie das Band der Balken.

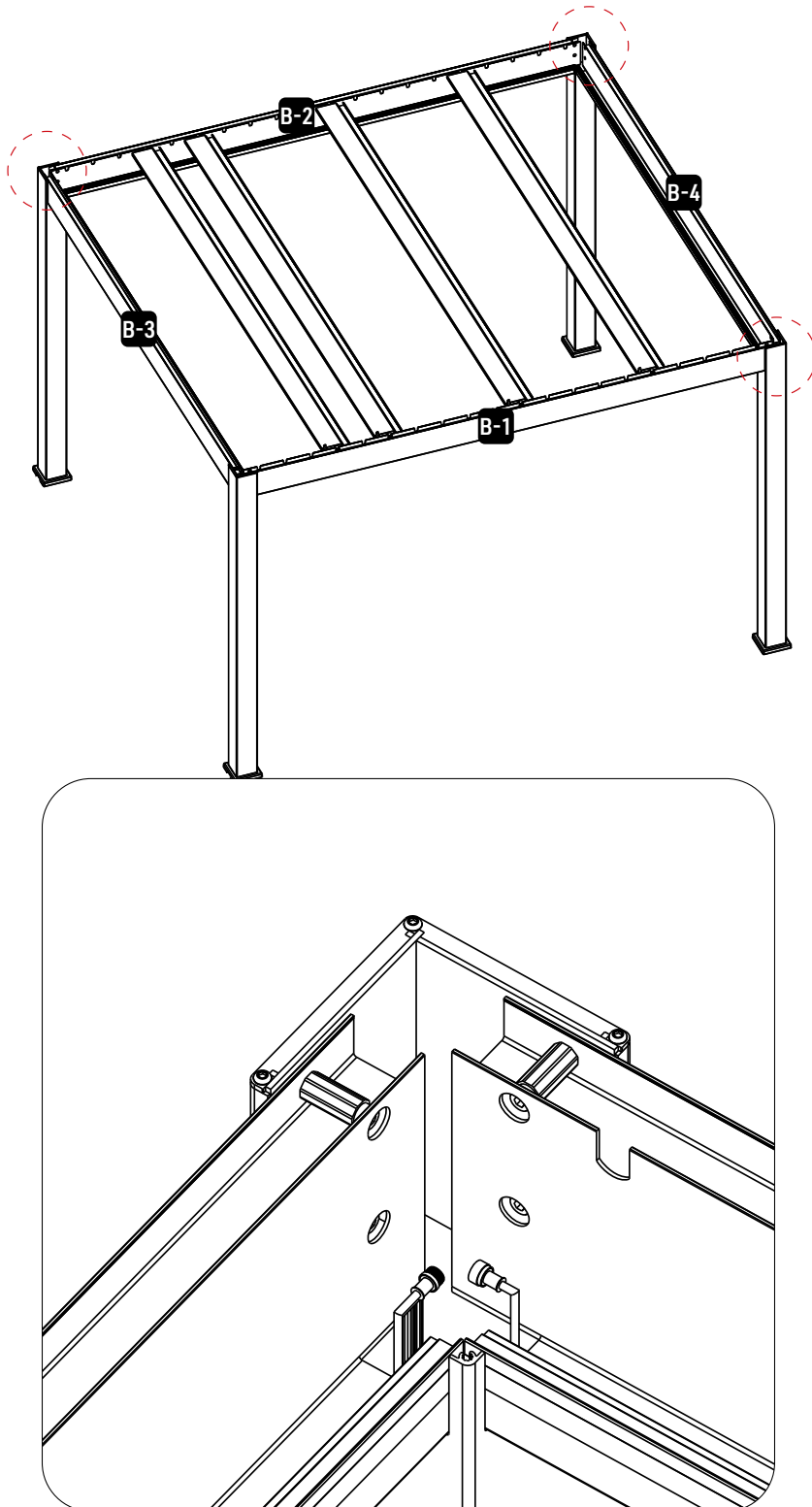

Schritt 5

5.9

Die Fernbedienung (E-C) hat die folgenden Funktionen:
- Steuerung des An- und Ausschaltens der LED
- Steuerung der Drehung der Lamellen

Wenn Sie die LED-Farbe steuern möchten, laden Sie bitte unten abgebildete die App unten herunter.

Die LED-Farbsteuerung ist nur verfügbar, wenn Sie Zugriff auf WLAN haben



Tuya Smart

Tuya APP Netzwerk-Verbindung

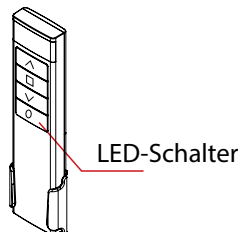

Wenn die LED beim Einschalten nicht verbunden werden kann, setzen Sie bitte den Controller der LED zurück.

Schalten Sie die LED 5 Mal hintereinander ein und aus.
Löschen Sie auch die vorherige Netzwerkverbindung. Wechseln Sie in den Smart Cong-Modus, die Ausgangs-LED blinkt dann 10 Mal.

Schritt 5

5.10

Nachdem Sie alle Kabel angeschlossen und die LED-Leiste sowie die Lamellenrotation eingestellt haben, legen Sie den Controller (E-C) in den Hohlraum des Balkens (B1), wie in der Abbildung unten gezeigt.

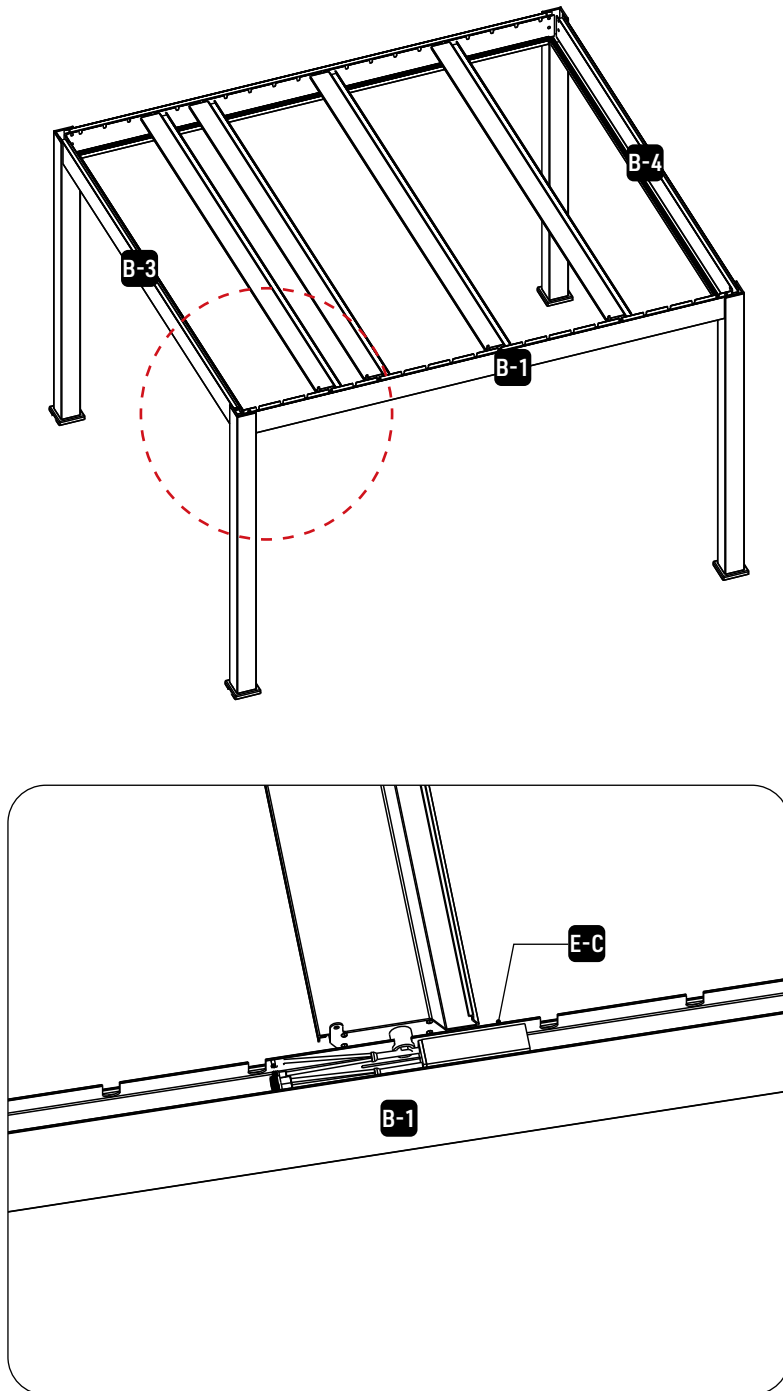







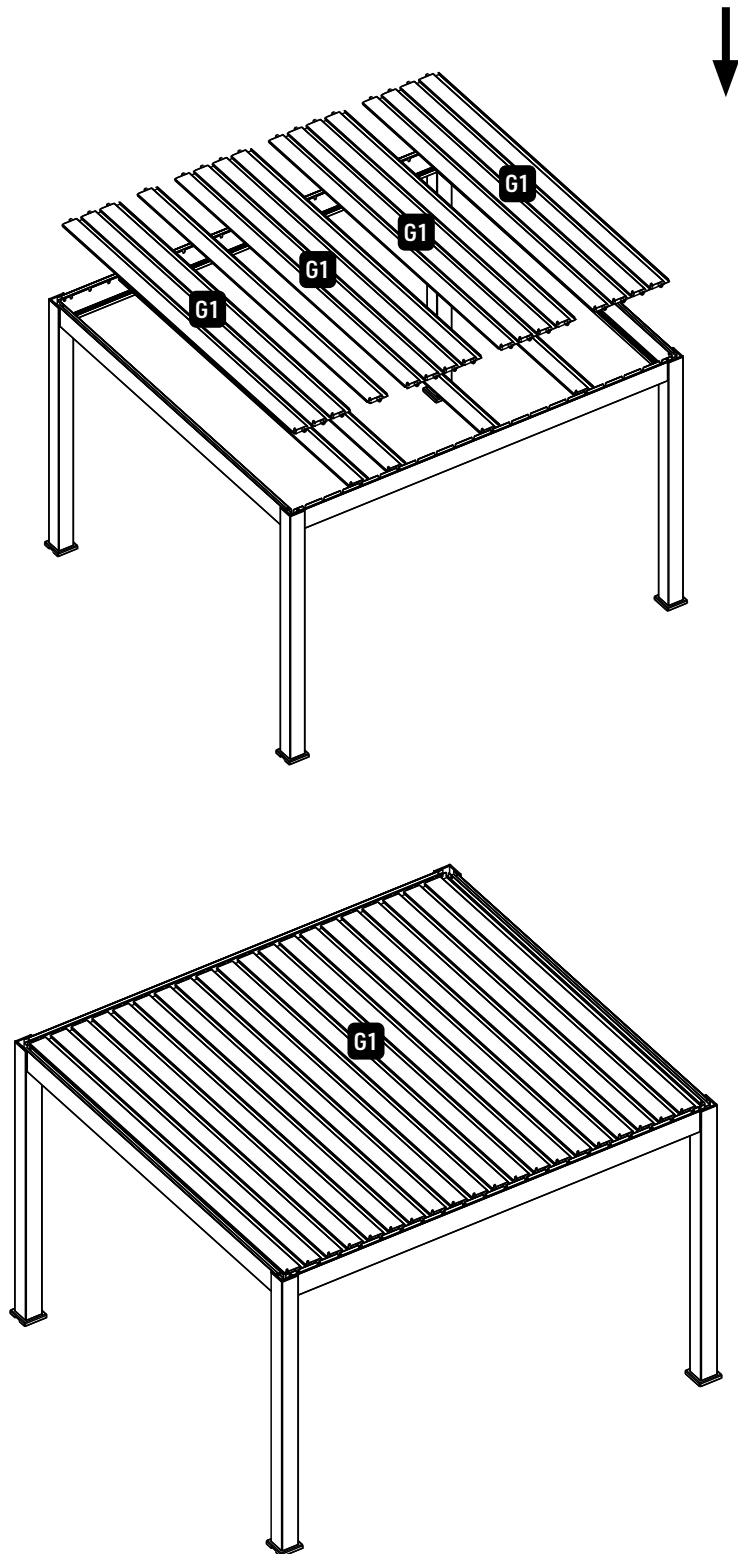

Schritt 6



6.1

Platzieren Sie die restlichen Lamellen.



Schritt 6

REF	BILD	MENGE
N13	 Kontermutter	20
N14	 Kunststoffmutter	20
N15		40
N16	 6x20  4mm	20
N19	 5x60  PH2	32
N20	 10x80	16
N21		4

REF	BILD	MENGE
F-1		1
D-1		2
D-2		2

6.2

Installieren Sie den Verbindungsbalen

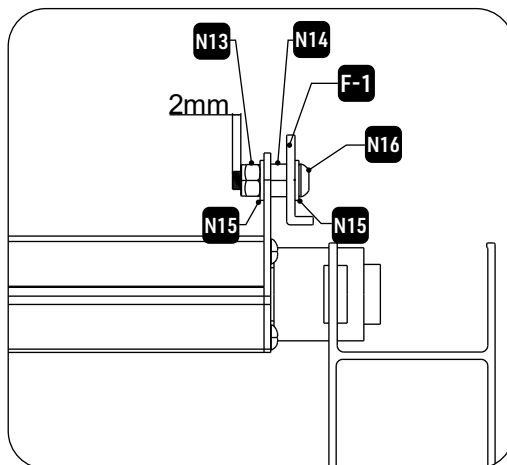
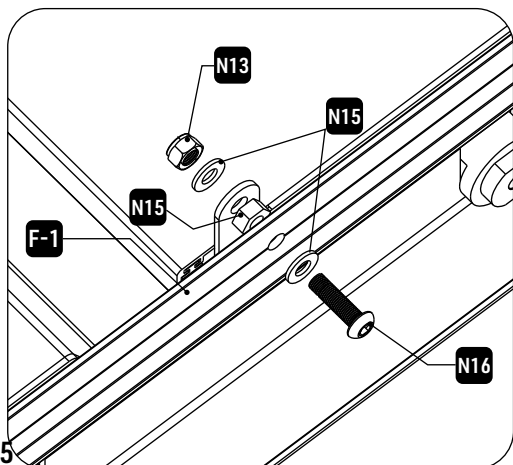
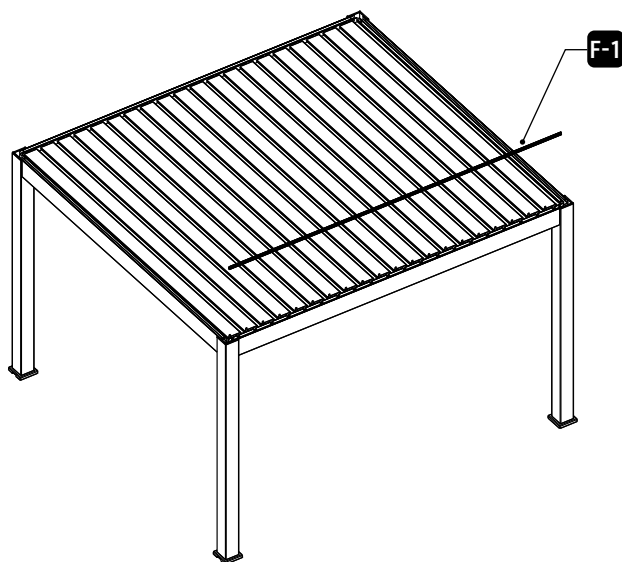

Schritt 6

6.4

Installieren Sie die Abdeckung auf den Balken.

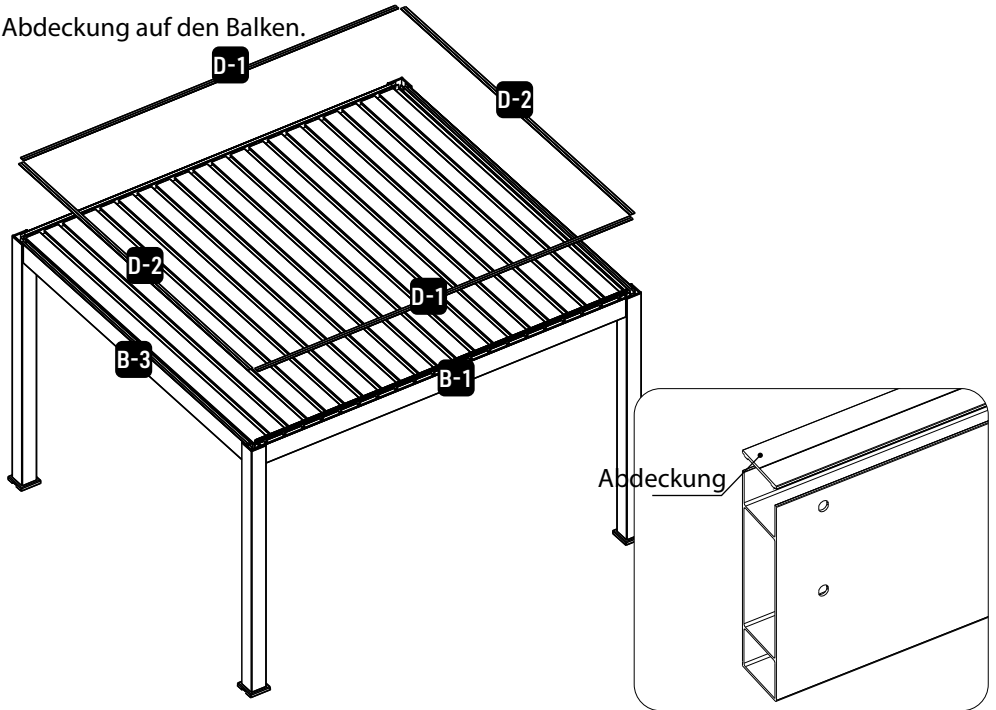

Verwenden Sie Schrauben, um die Abdeckung am Balken zu befestigen.

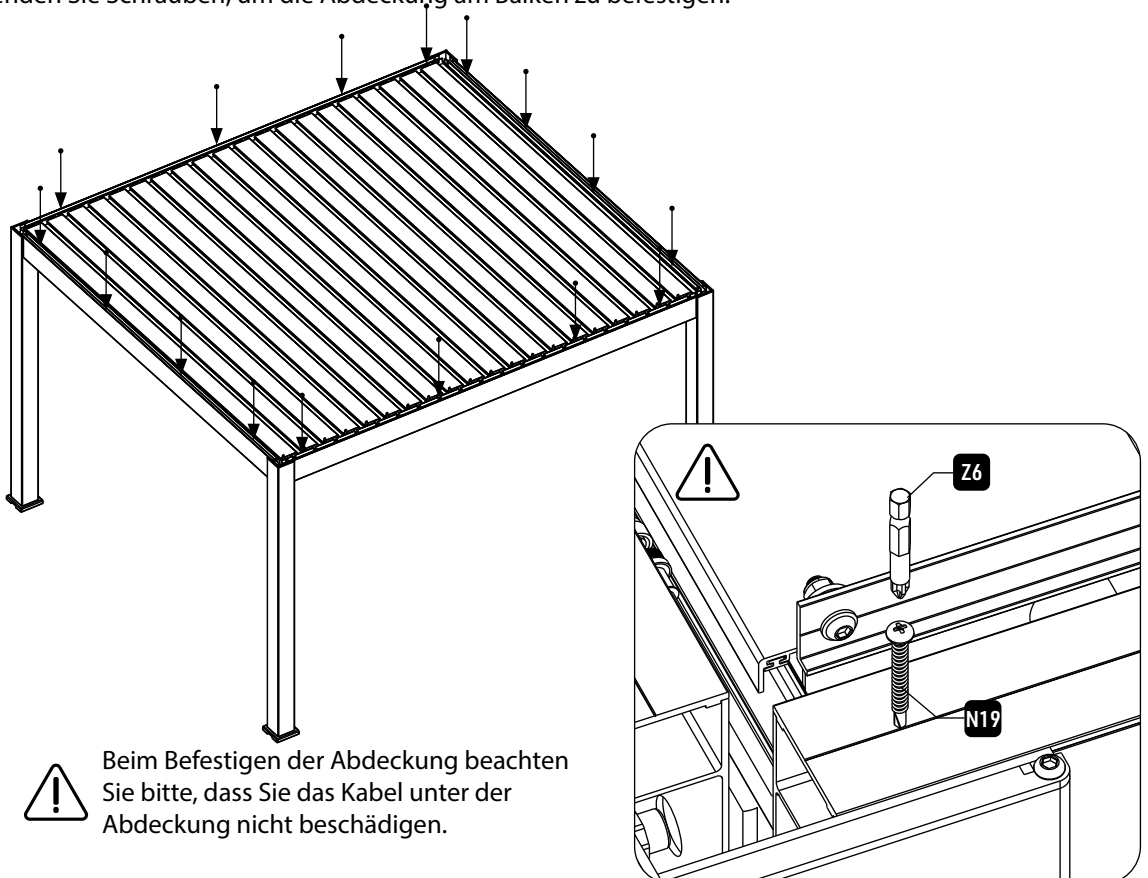

Beim Befestigen der Abdeckung beachten Sie bitte, dass Sie das Kabel unter der Abdeckung nicht beschädigen.

Schritt 6

6.5

Installieren Sie die Abdeckung des Pfostens.

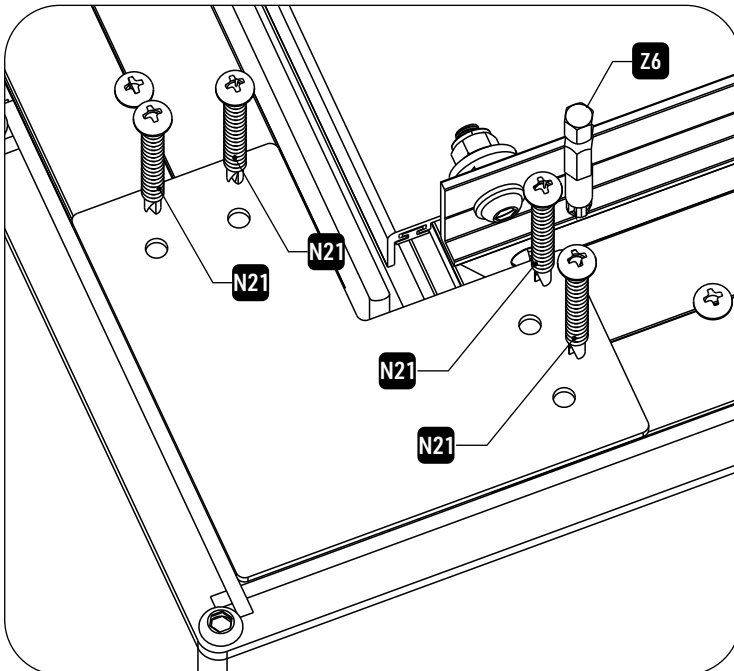
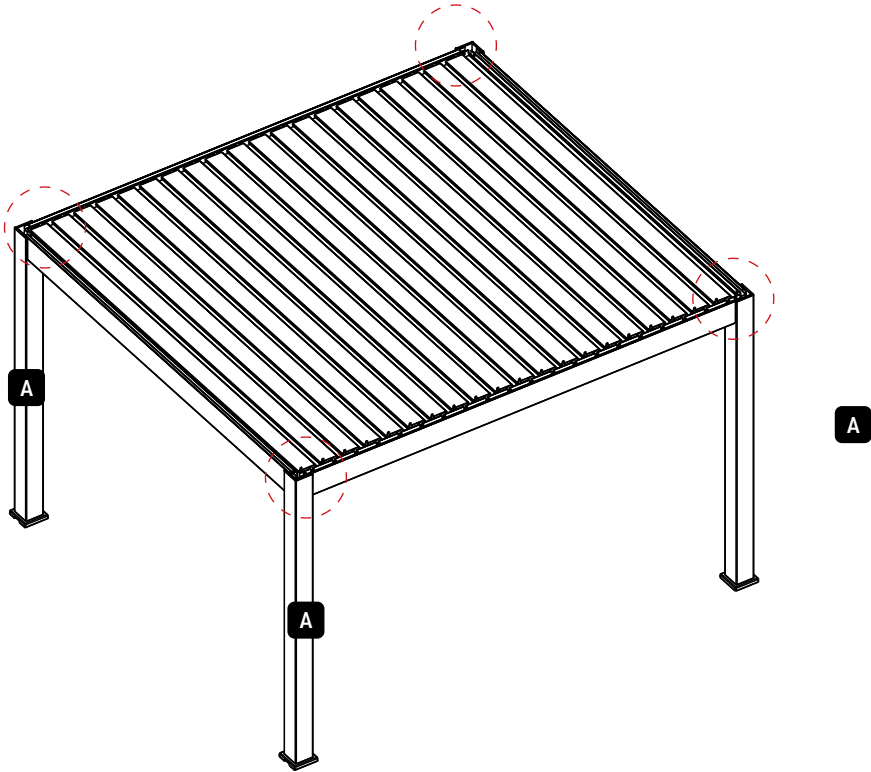

Schritt 6

6.6

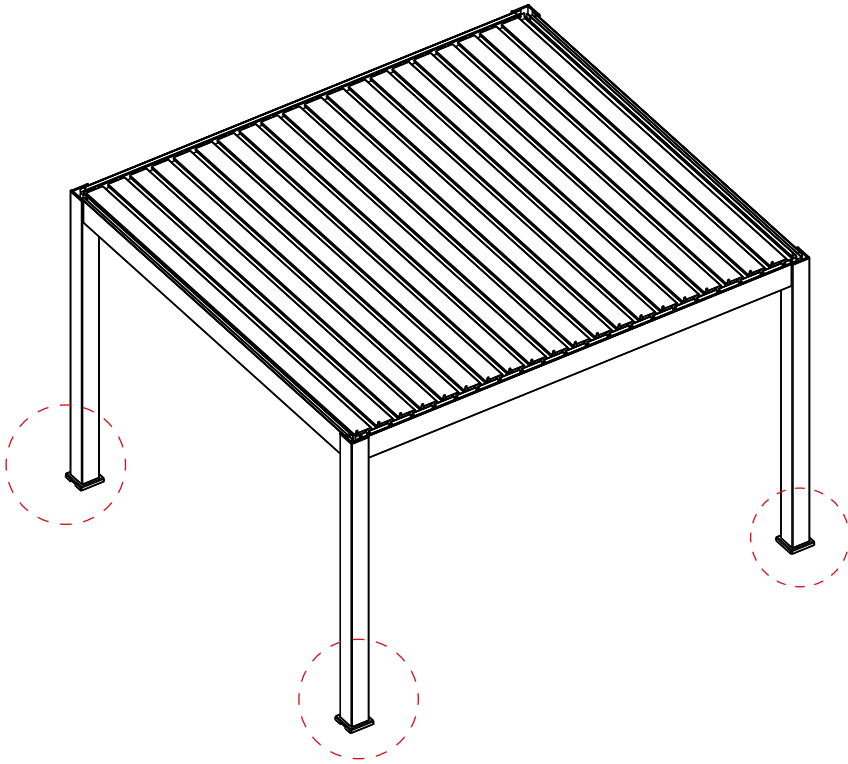

 Bitte überprüfen Sie, ob alle Fundamentmaße korrekt sind, und befestigen Sie dann alle Grundplatten.

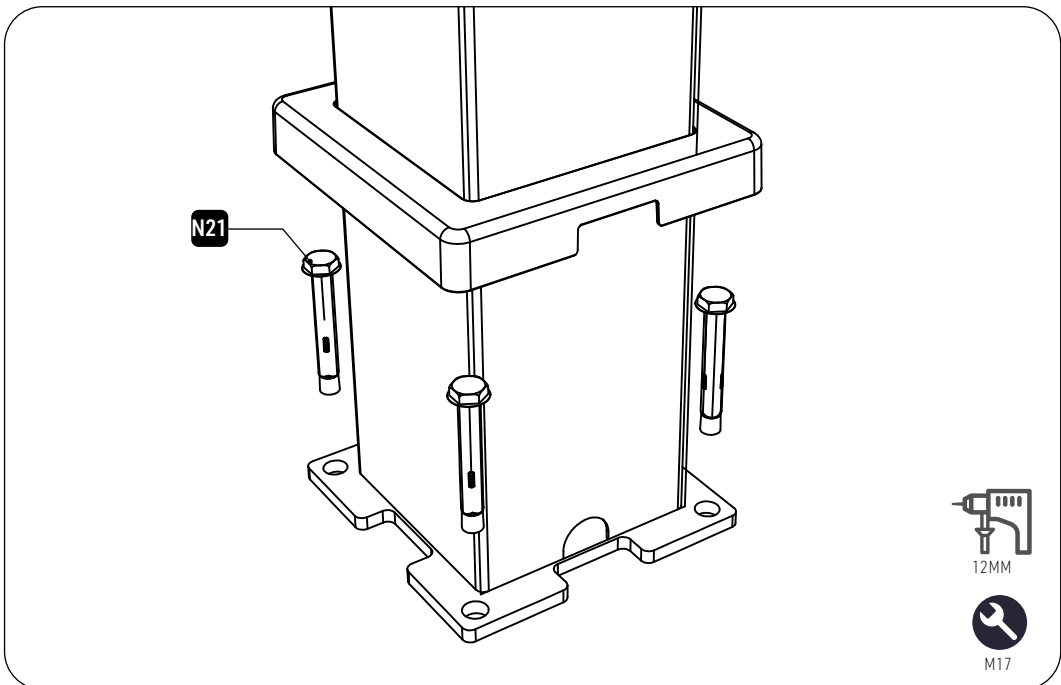

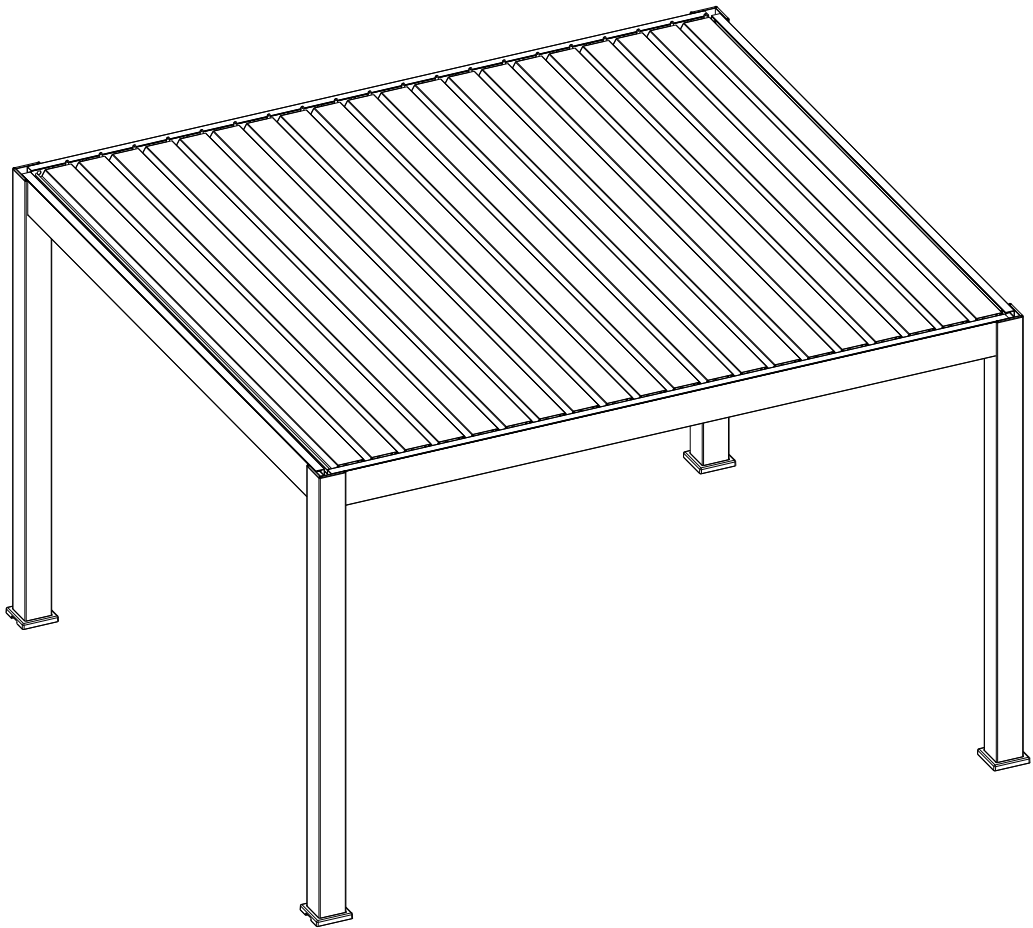

PRESTIGE-ELECTRIC PERGOLA 3.6×4M

Assembly Instructions - EN

These instructions have to be saved during the whole product life cycle. We advise you to read these very carefully before proceeding to the assembly. The user will be reliable for any damages or injuries caused due to incorrect or improper installation.

TIPS AND SAFETY INSTRUCTIONS

Depending on the location and surface area, construction may be subject to building permits. Make sure you have checked with your local authorities to obtain the needed information before the assembly.

Product assembly :

- At least 2/3 people required
- Remove protective film (around 1 hour needed)
- Do not keep children near the assembly area
- Beware of the risk of pinching
- Do not tighten the screws before assembling the whole product
- All assembly steps must be carefully followed
- Check the level of the structure on all sides
- Do not anchor the pergola before assembling the whole product

No changes can be made to the product. Products tampered with by the user are not covered by the warranty, thus being declared as void.

The location should be chosen carefully. It is recommended to avoid mounting your pergola on a rainy day, facing the prevailing winds, and under an overhanging tree.

The pergola must be mounted on a flat-level foundation. It is recommended to install it on a concrete slab or 25x25 cm concrete pads at each post. Please, anchor the pergola properly to the ground using expansion screw.

If you would like to mount your pergola near your house or a building, please check the presence of gutters for water drainage.

Should these instructions not be followed or only partially, the warranty will be voided by the seller.

MAINTENANCE

Regular maintenance is necessary to ensure its longevity and aesthetic appearance.

We recommend to :

- Clean your pergola once or twice a year with fresh water using a sponge or cloth.
- Do not use detergent or an abrasive material.
- Check the tightness of the screws regularly (at least once a year).
- Oil fastening regularly (at least once a year).
- Make sure that nothing hinders the water flow in the gutters (leaves, branches...).
- Remove any water that might stagnate around the legs of the pergola (lift the posts skirts).

PRECAUTION OF USE

This product should not be used in extreme weather: storms, violent winds, hail, and snow. We guarantee the resistance of the pergola for winds up to 88 km/h and a maximum snow weight of 70kg/m².

As in the case of strong winds or snow, we highly recommend leaving the louvers open. To maintain good working conditions of your louvers, please clear any snow on them.

Our pergola can withstand heavy rain, but we cannot guarantee it will be 100% waterproof due to some extreme weather conditions.

Exceptional climatic events may compromise the perfect sealing of the product.

To avoid any damages and injuries, we do not recommend climbing on the roof or the structure of the pergola.

MAINTENANCE

This warranty does not cover :

- Normal wear and tear inherent from the products.
- Loss or breakage of any part during unpacking or installation.
- Lack of care, neglect, vandalism, impact with foreign body, force, contact with a abrasive material, product aesthetics, disassembly, rebuilding or relocation.
- Force majeure: hail, high winds, storms, snow, floods, lightning etc...
- Product tampered with by the user.

The warranty only takes in account the replacement of spare parts or the provided product, no refund will be issued.

All warranty claims must be made at the sales outlet (store or website) where the product has been purchased.

PARTS LISTS (PER CARTON)

Before proceeding with the assembly of your louvered pergola, it is necessary to check that all parts listed are supplied and not damaged.

Any missing part must be reported within 10 days of delivery.

You can either go through your local outlet store or make the request directly on our website.

Do not discard the packaging without ensuring that the product is functioning properly.

NECESSARY TOOLS AND SAFETY GEAR (NOT SUPPLIED)

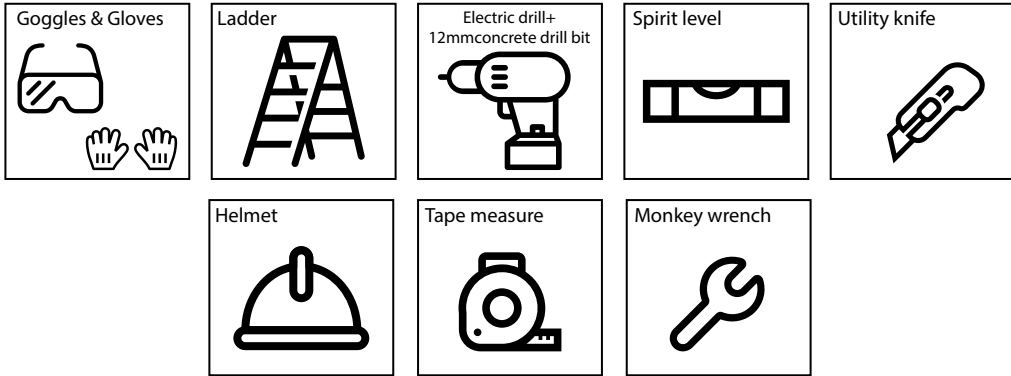

FOOTING MEASUREMENT (2D dimensions in mm)

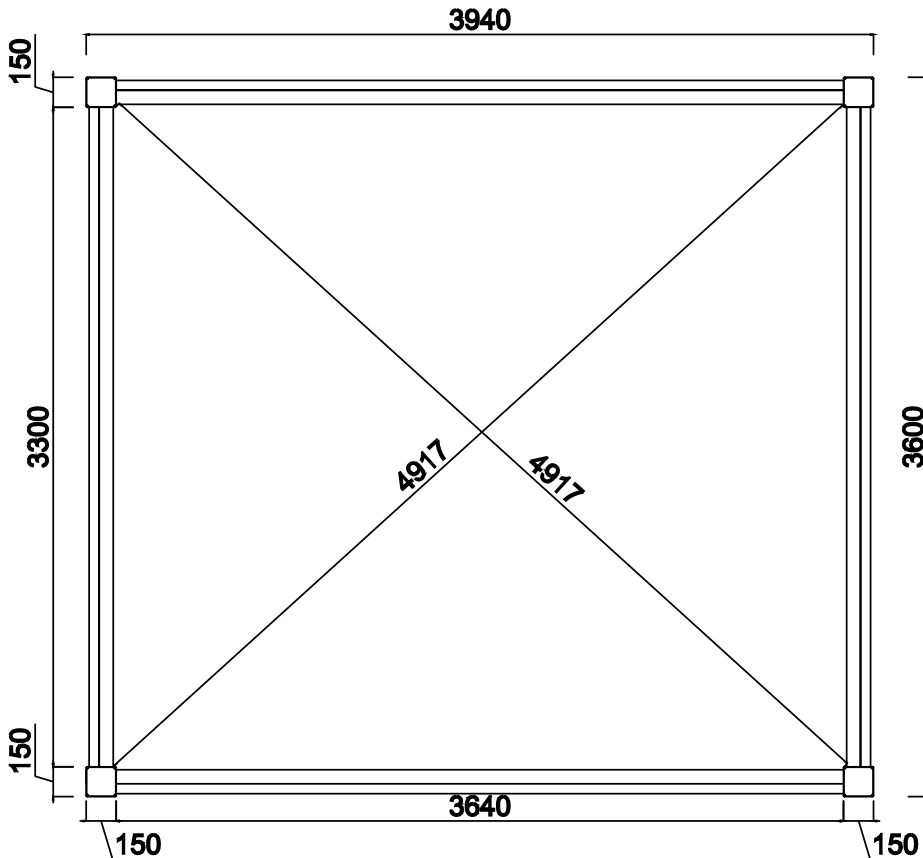

FOOTING MEASUREMENT (2D dimensions in mm)

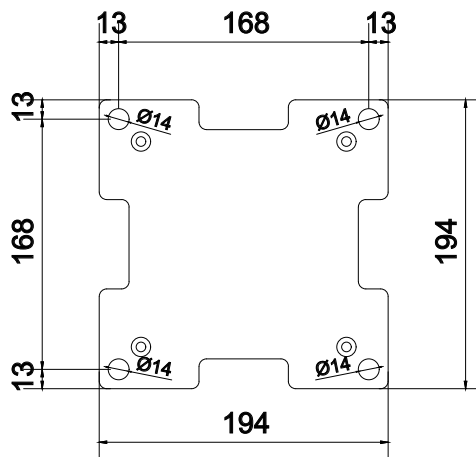
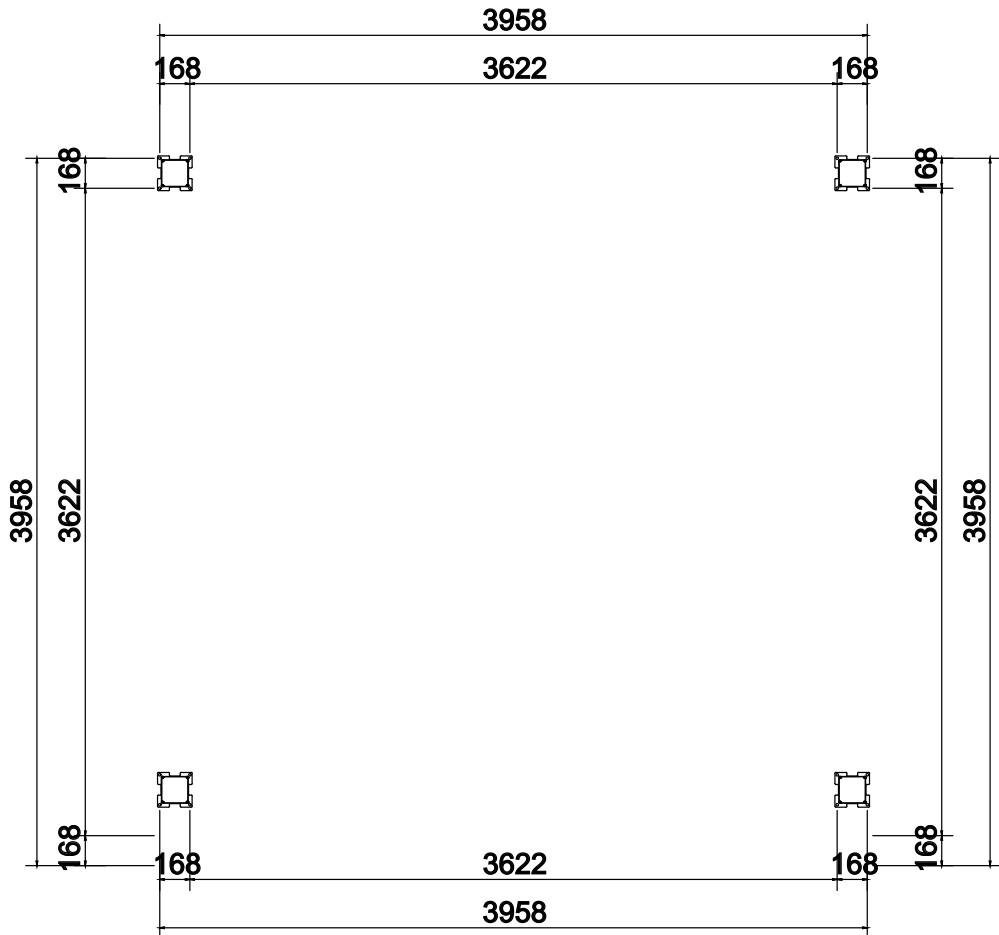



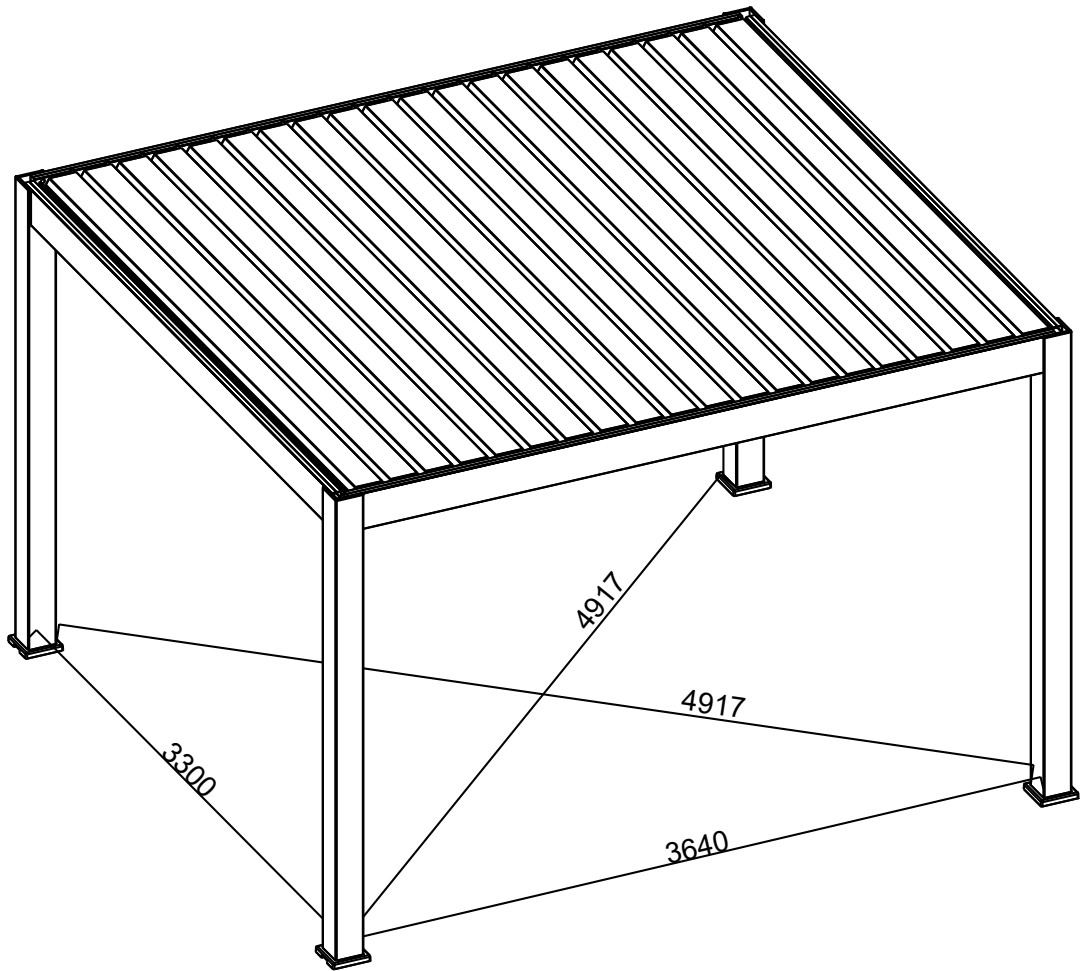





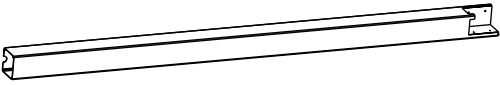

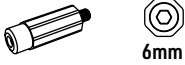

FOOTING MEASUREMENT (3D dimensions in mm)

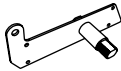

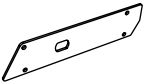







PARTS LISTS (PER CARTON)

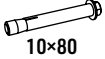

CARTON 1/5(POSTS AND LOOSE PARTS)

REF	PICTURE	QTY
A		4

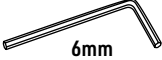
REF	PICTURE	QTY
N1		4
N2		4
N3		16
N4		16
N5		1
N6		19
N7		20
N8		39
N9		40
N10		40
N11		39
N12		39
N13	 lock nut	20

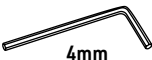





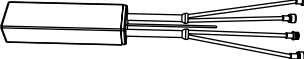
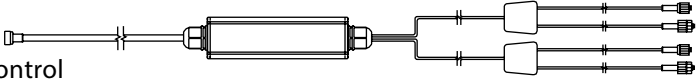

REF	PICTURE	QTY
N14	 plastic nut	20
N15		40
N16		20
N18		16
N19		32
N20		16
N21		4
N22		160

REF	PICTURE	QTY
Z1	 6mm	1
Z2	 6mm	1
Z3	 4mm	1

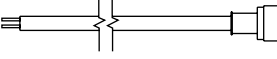



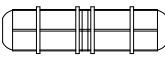

REF	PICTURE	QTY
Z4	 4mm	1
Z5	 10mm	1
Z6	 PH2	1

CARTON 1/5(POSTS)

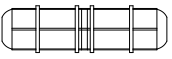
Electrical products

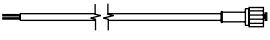

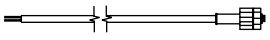
REF	PICTURE	QTY
E-C	Controller 	1
E-L	LED control 	1
E-R	Remote control 	1
E-P	Power cable(M15)  	1
E-W2	Waterproof joint(2)  	1
E-W3	Waterproof joint(3)  	1

LED cable

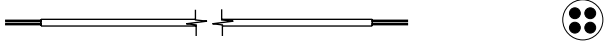
REF	PICTURE	QTY
E-W4	Waterproof joint(4)  	5
L-C1	 	4
L-C2	 	4

REF	PICTURE	QTY
L-CL		1

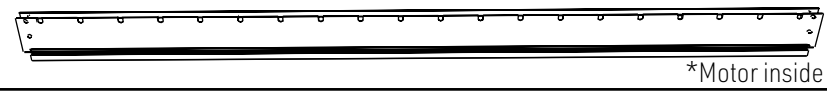
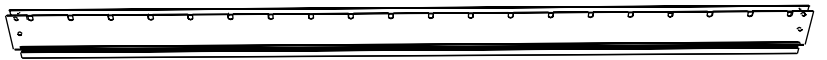
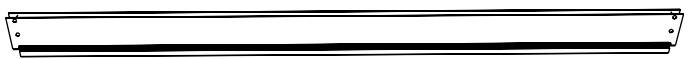
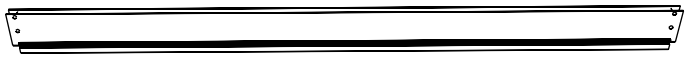
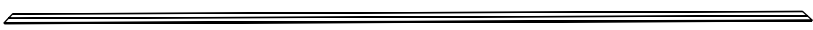
CARTON 2/5(POSTS AND LOOSE PARTS)

REF	PICTURE	QTY
B-1		1
B-2		1
B-3		1
B-4		1
D-1		2
D-2		2
F-1		1



ATTENTION!

Connecting Bar(F-1) & Brush Inside!

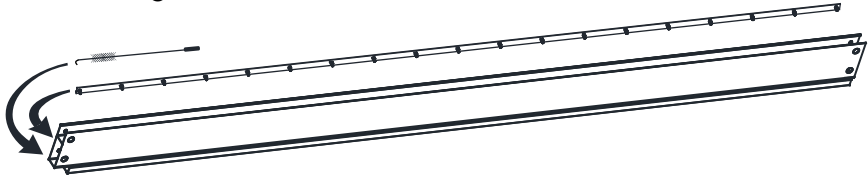

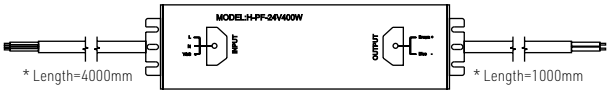

REF	PICTURE	QTY
E-T		1
Transformer		



CARTON 3/5&4/5(POSTS AND LOOSE PARTS)

REF	PICTURE	QTY
G1		7

CARTON 5/5(POSTS AND LOOSE PARTS)

REF	PICTURE	QTY
G1		3
G2		3

Step 1

REF	PICTURE	QTY
N1		4
N2		4

REF	PICTURE	QTY
A		4

Electrical

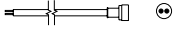
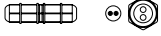
REF	PICTURE	QTY
E-P		1
E-W2		1

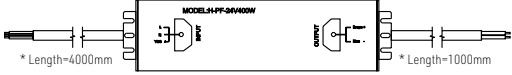
REF	PICTURE	QTY
E-T		1

1.1

Please connect the output line(E-T) with power cable(E-P) of the transformer by using the waterproof points(E-W2).

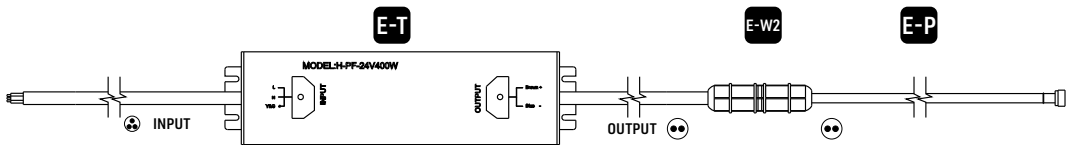

1.2

- Please insert the input line of the transformer into the cavity of the post.
- Pull the input line from the drainage outlet of the post.
- Install the plate and skirt of the post after pulling out the input line.

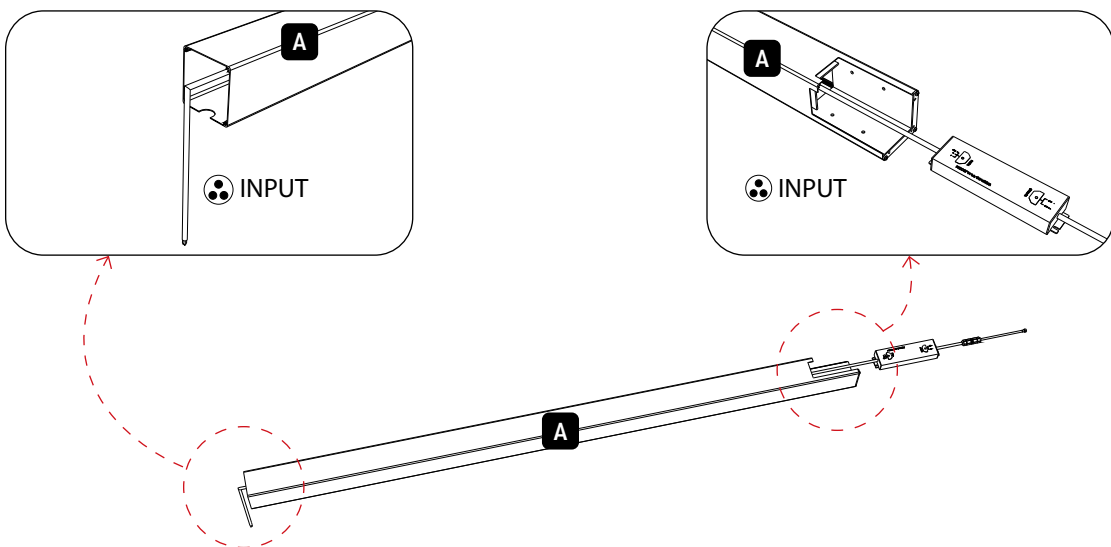

Step 1

1.3

Put the skirt(N1) on the post(A), please note that notch on the skirt and the drainage outlet of the post should be align as the diagram shows below.

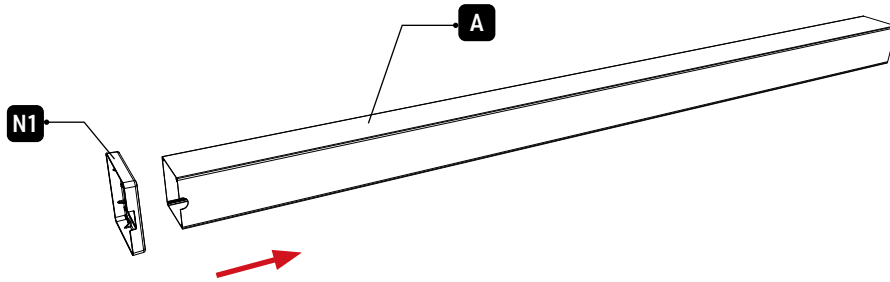

Install the plate

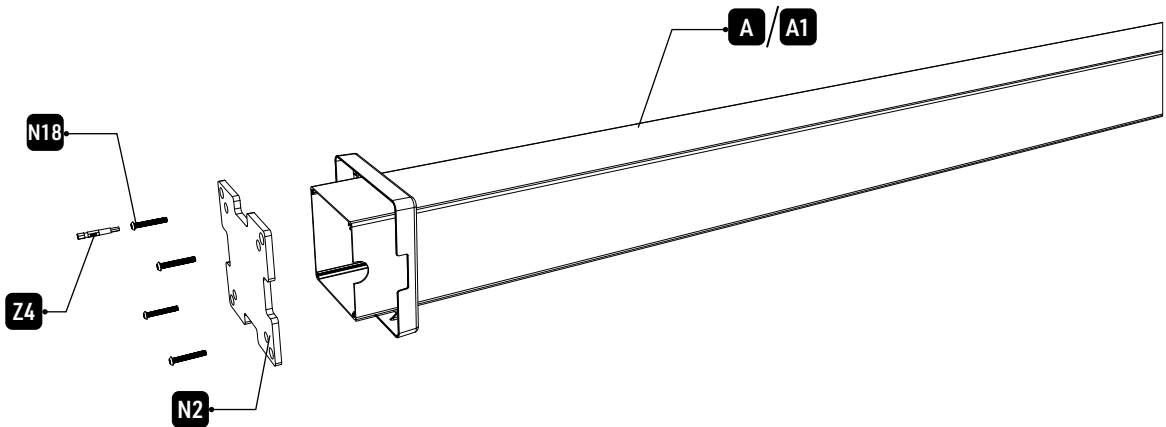

Using the pistol drill to fix screws on the plate, please tighten screws with the spanner.

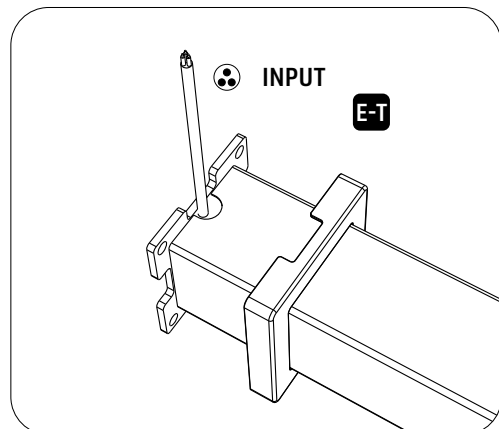
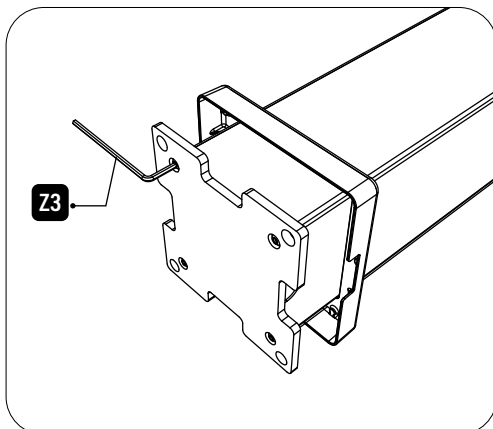

Step 2

REF	PICTURE	QTY
N3		8

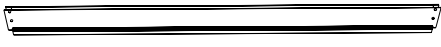
REF	PICTURE	QTY
B-3		1
B-4		1

2.1

Insert the transformer into the cavity of B-3, please note to reserve enough length of the power cable(E-P).

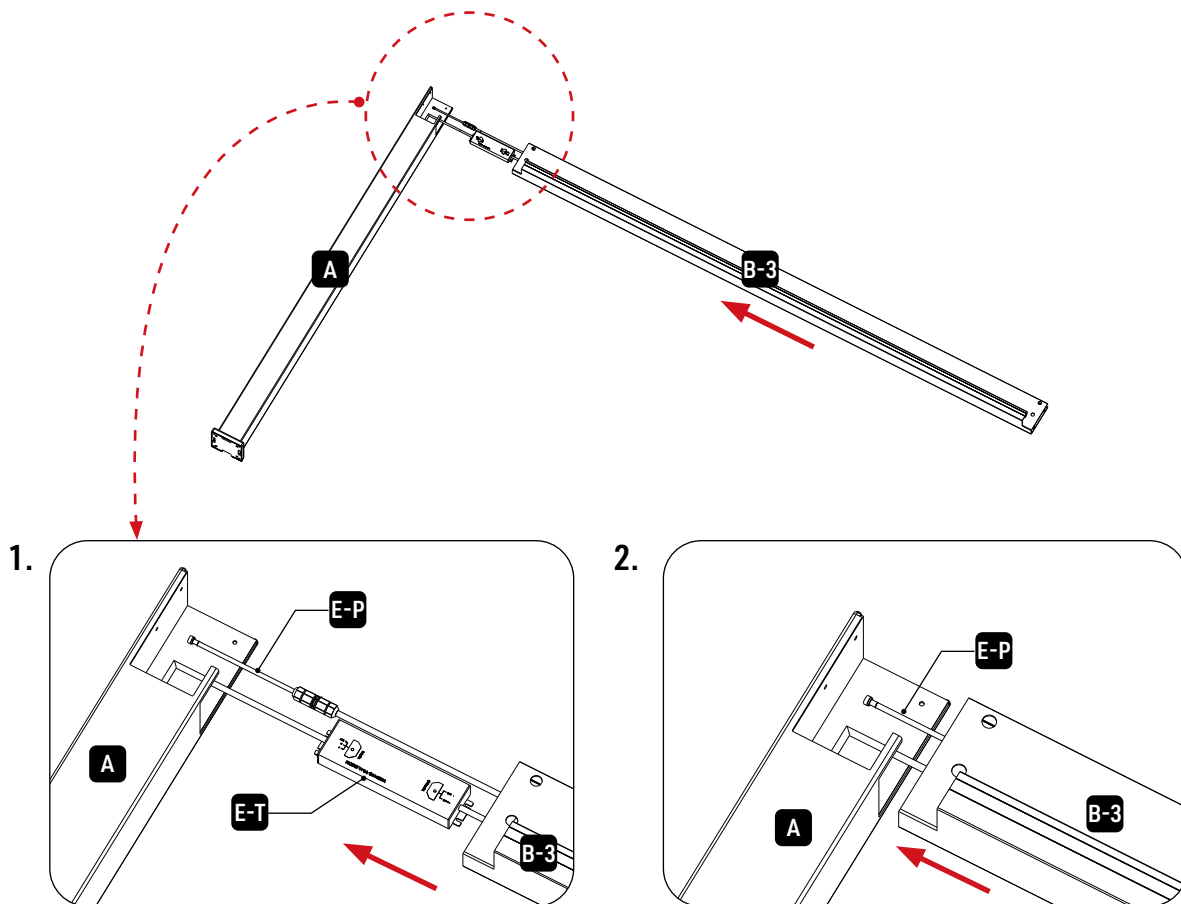

Step 2

2.2

- Connect the beam(B-3) with the post(A) as the diagram shown below.
- Please remember to keep the power cable(E-P) outside of beam.

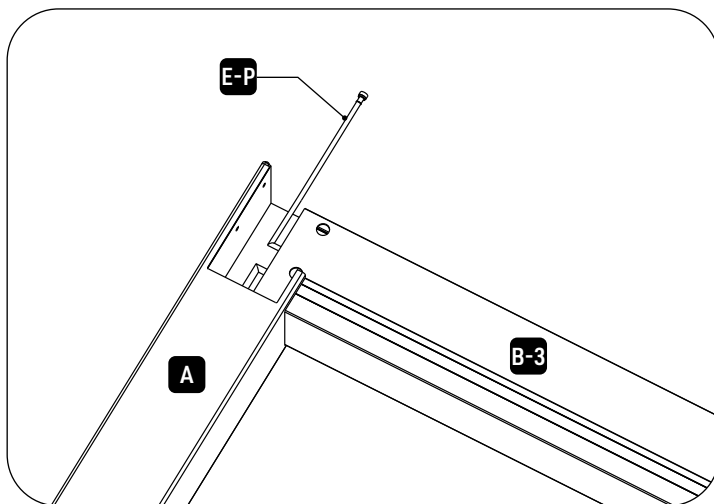

2.3

Using the pistol drill to fix screws on the post, then tighten screws with the spanner.

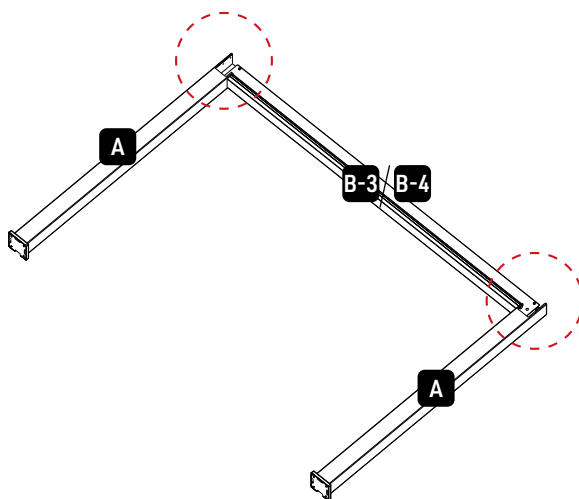



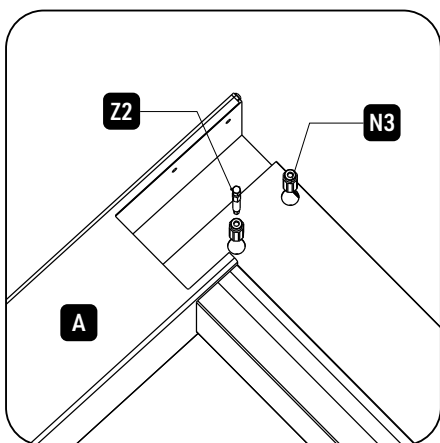

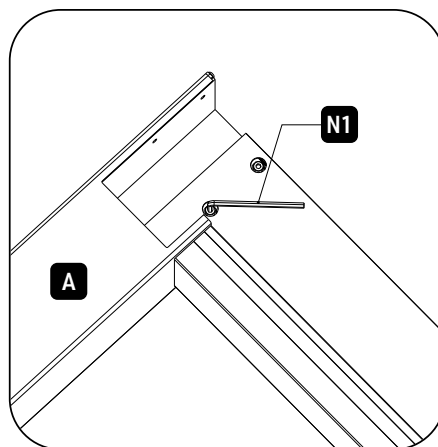

1.



2.

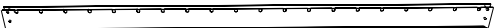

Step 3







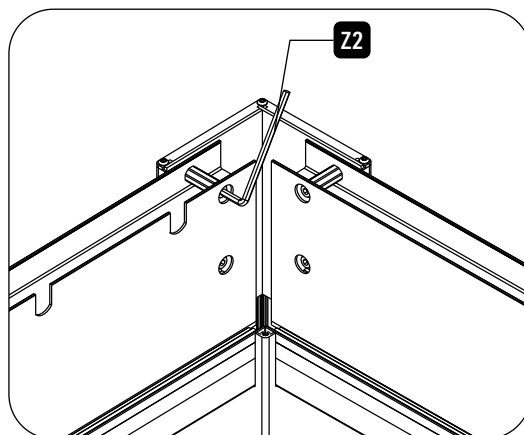
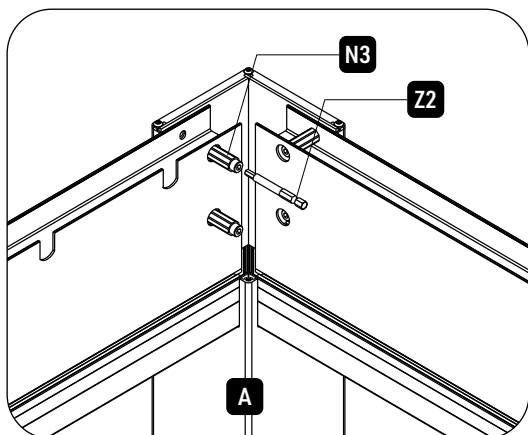
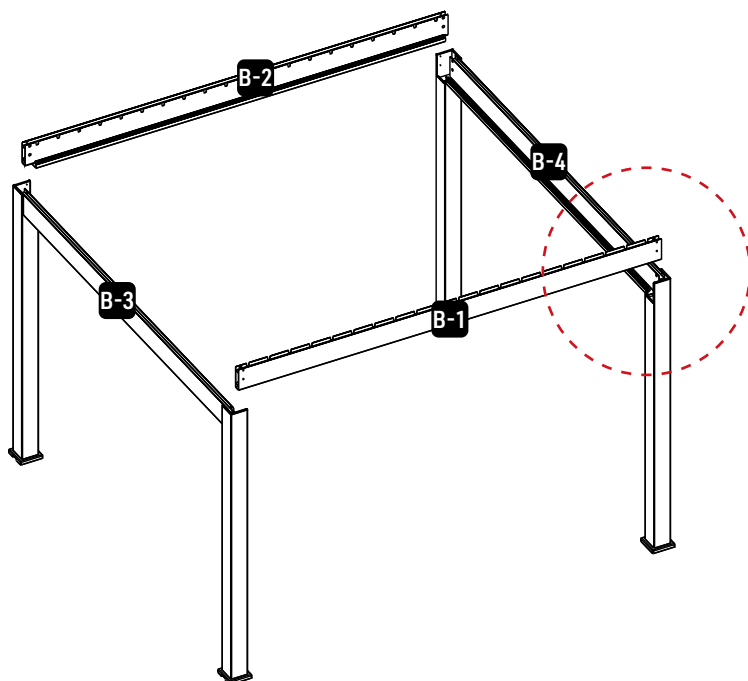

REF	PICTURE	QTY	REF	PICTURE	QTY
N3	  6mm	24	B-1	 <small>*Motor inside</small>	1
			B-2		1
			B-3		1
			B-4		1

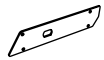

3.1

Connect beams to posts.



Step 4

REF	PICTURE	QTY
N5		1
N6		19
N7		20
N8		39
N9		40
N10		39
N11		39
N12		39

REF	PICTURE	QTY
G1		17
G2		3

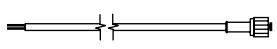
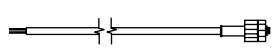
REF	PICTURE	QTY
L-L1		3
L-L2		3

4.1

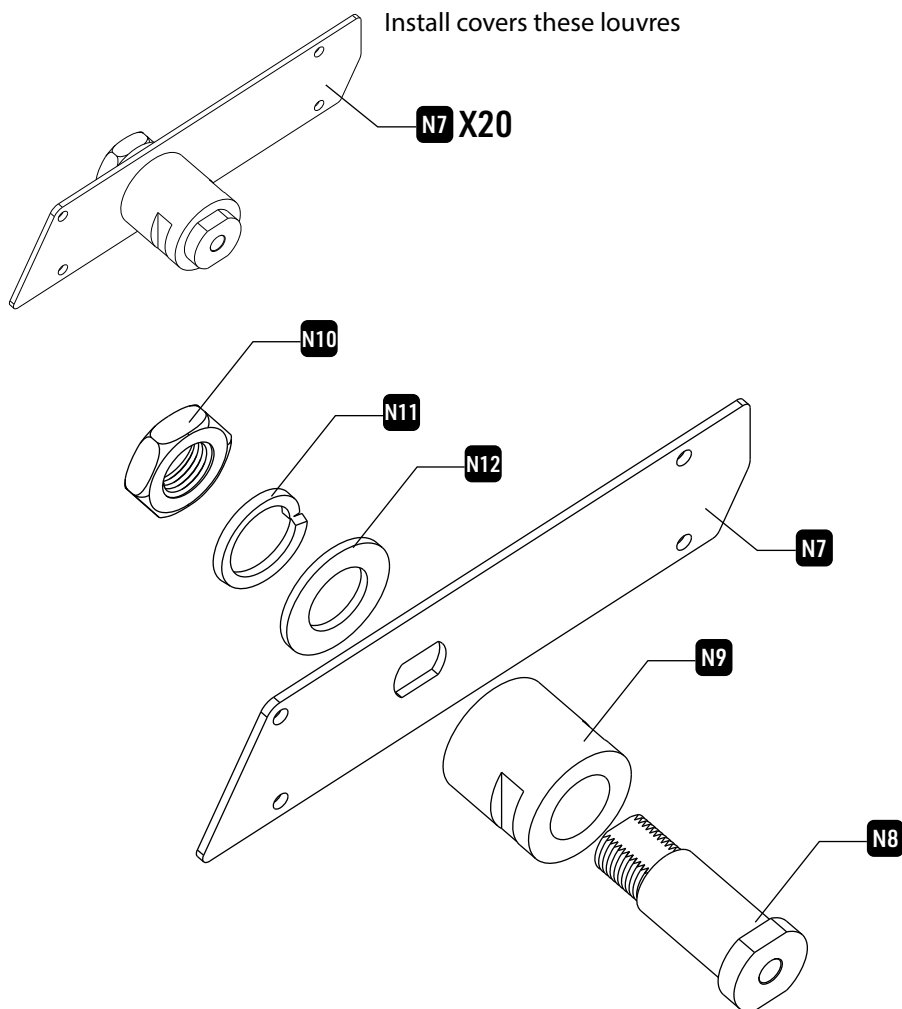

Step 4

4.1

Install the cover for louvre as the diagram shows below.

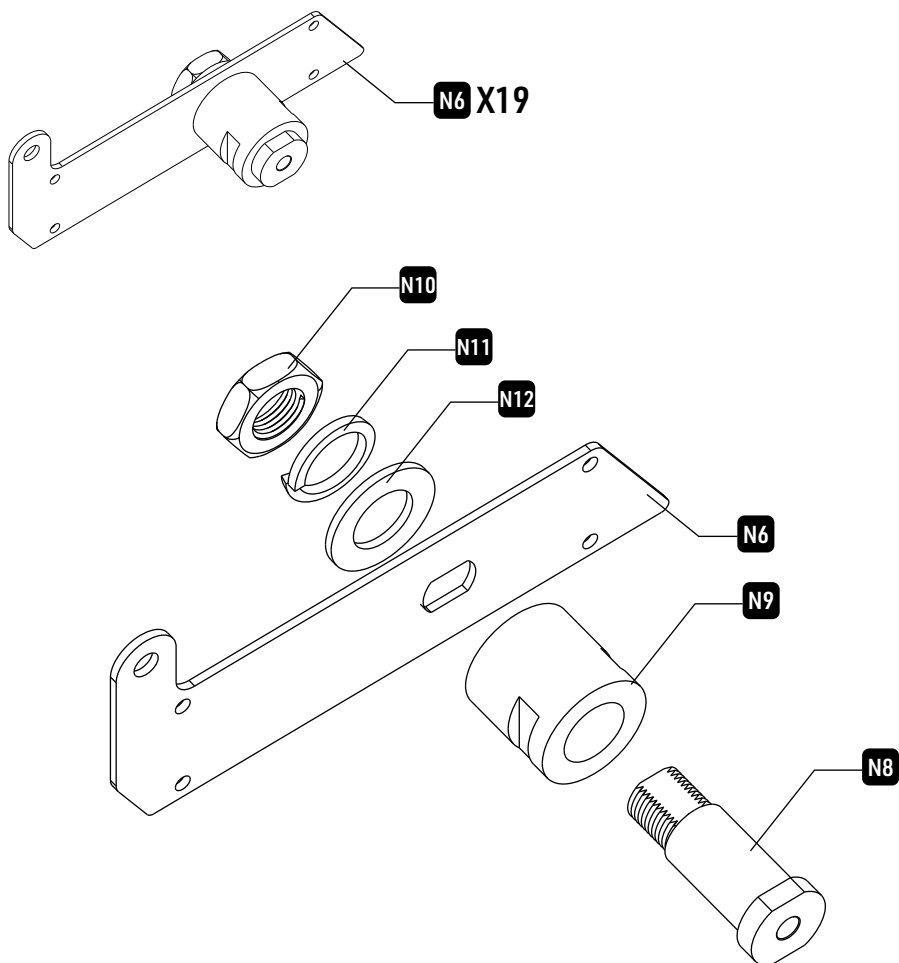

Please note to differ the main louvre's cover and install the nut as the diagram shown below.

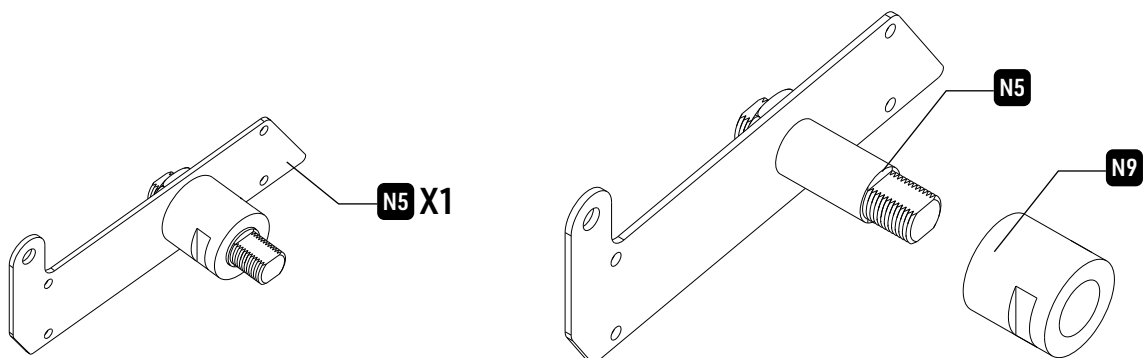

Step 4

4.2

Install the cover for the main louvre.

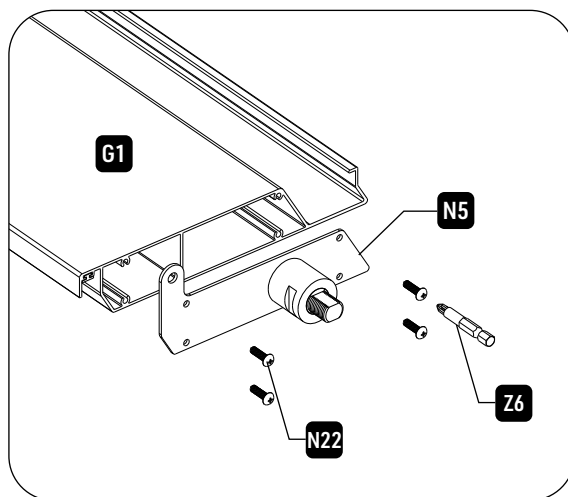
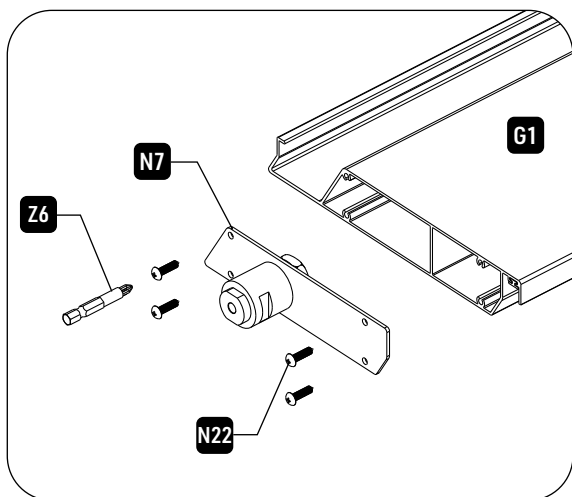
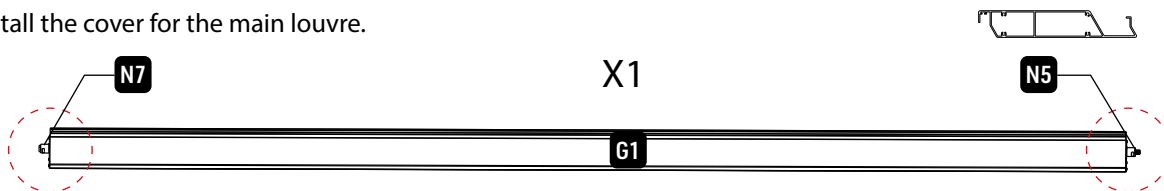

Install the cover for other louvres.

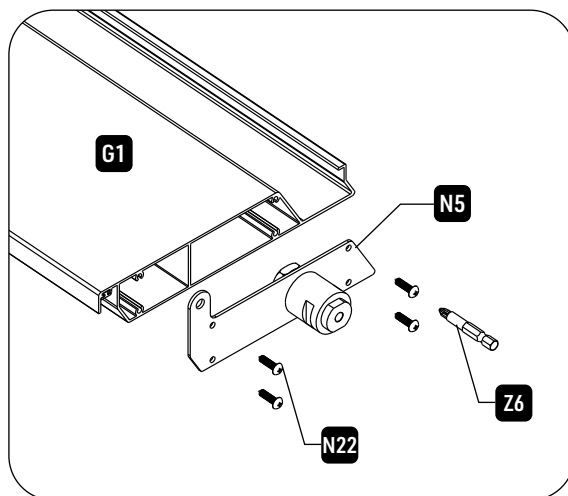
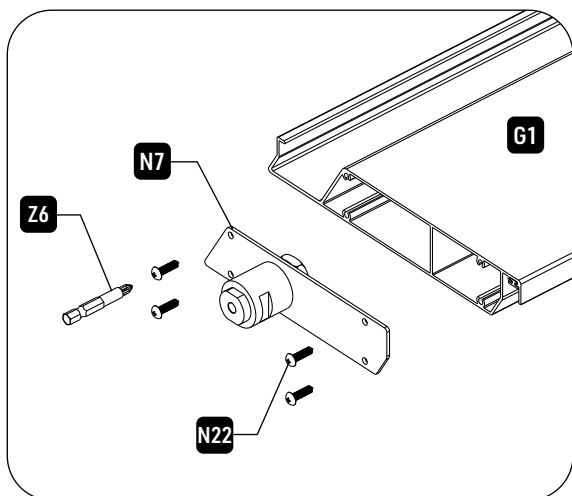
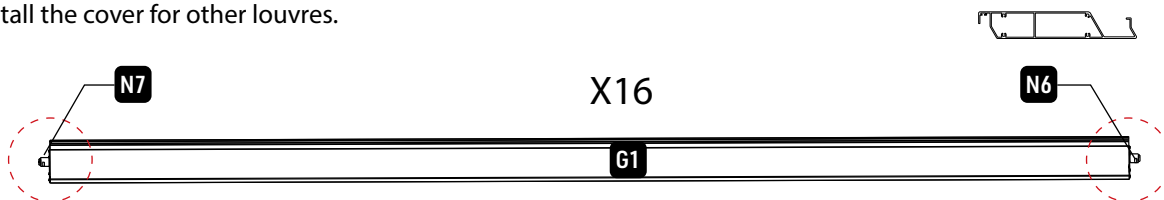

Step 4



4.3

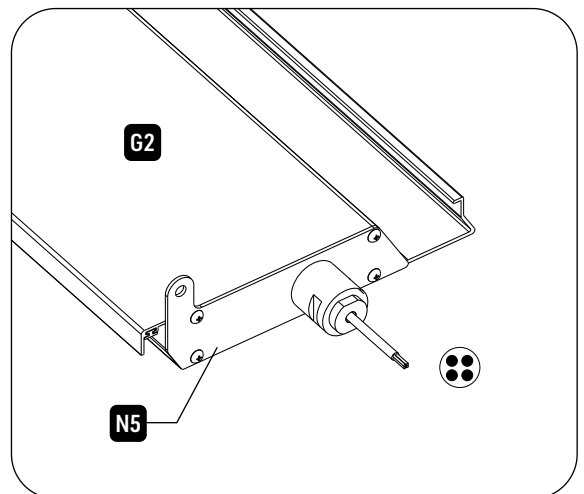
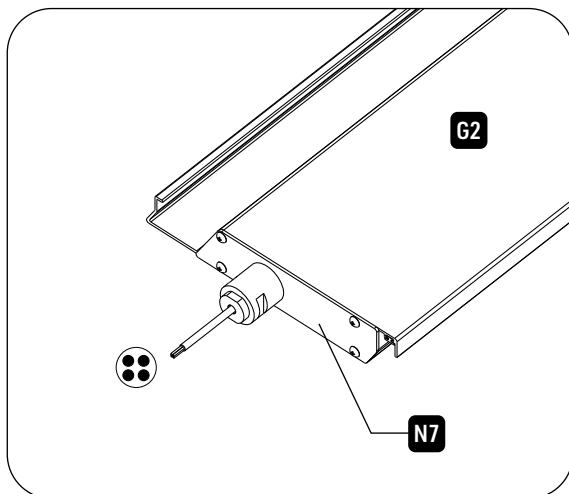
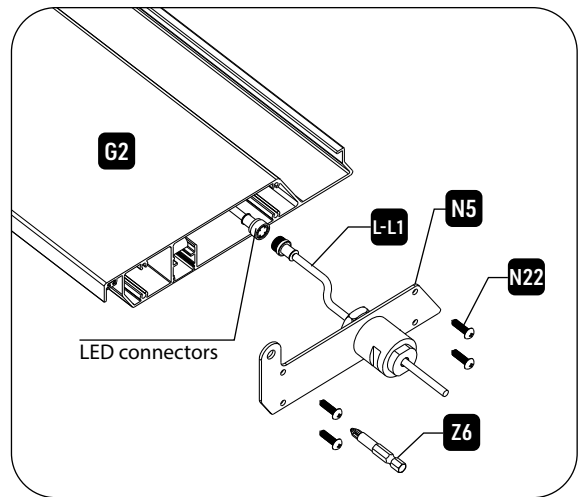
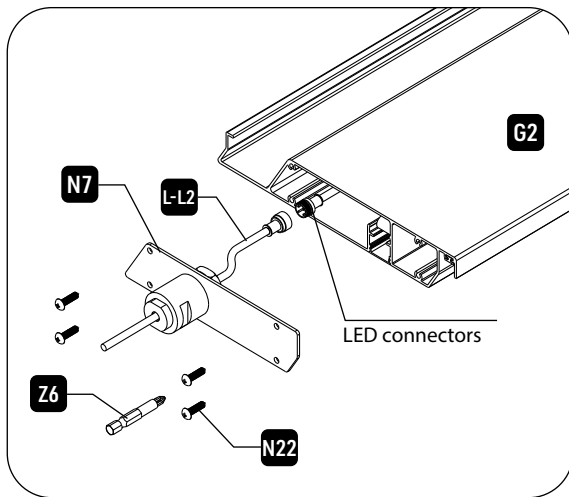
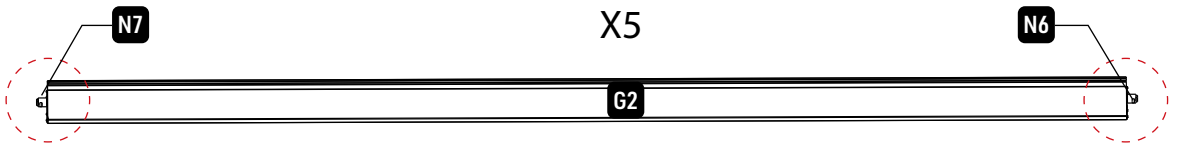

Install the Louvre with LED Connectors.

- Please find the louvres with the LED belt first
- Connect the L-L1 on the louvre cover with LED connectors on one end of the louvre, then connect L-L2 with LED connectors on the other end
- Please note that the end of L-L1 & L-L2 should go through the nut of the louvre cover and leave the ends on the outside as the diagram shows below

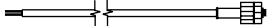
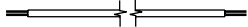

Step 5

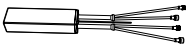
REF	PICTURE	QTY
L-L1		1
L-L2		1
L-CL		1
E-W4		2

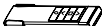
REF	PICTURE	QTY
E-C		1
L-C2		1
E-R		1

5.1

Place the main louvre (G1) as the diagram shows below, then connect the main spindle (N5) with the swing arm of the motor, and fasten it with the nut (N10).

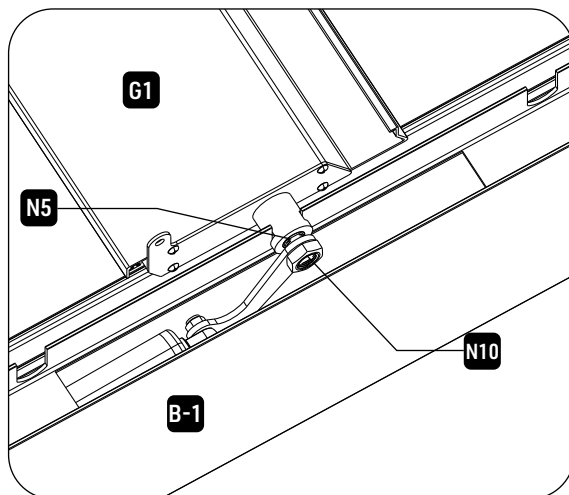
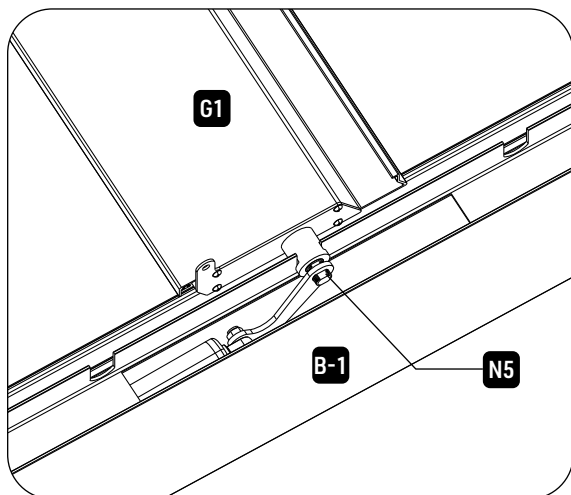
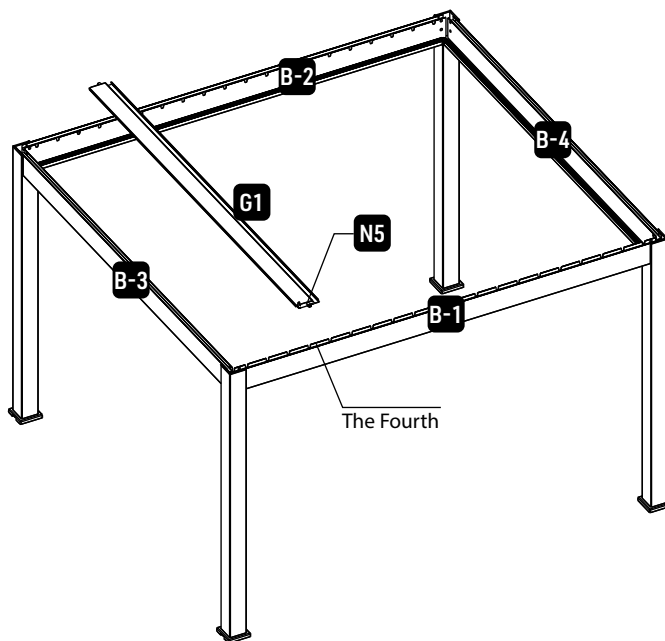

Step 5

5.2

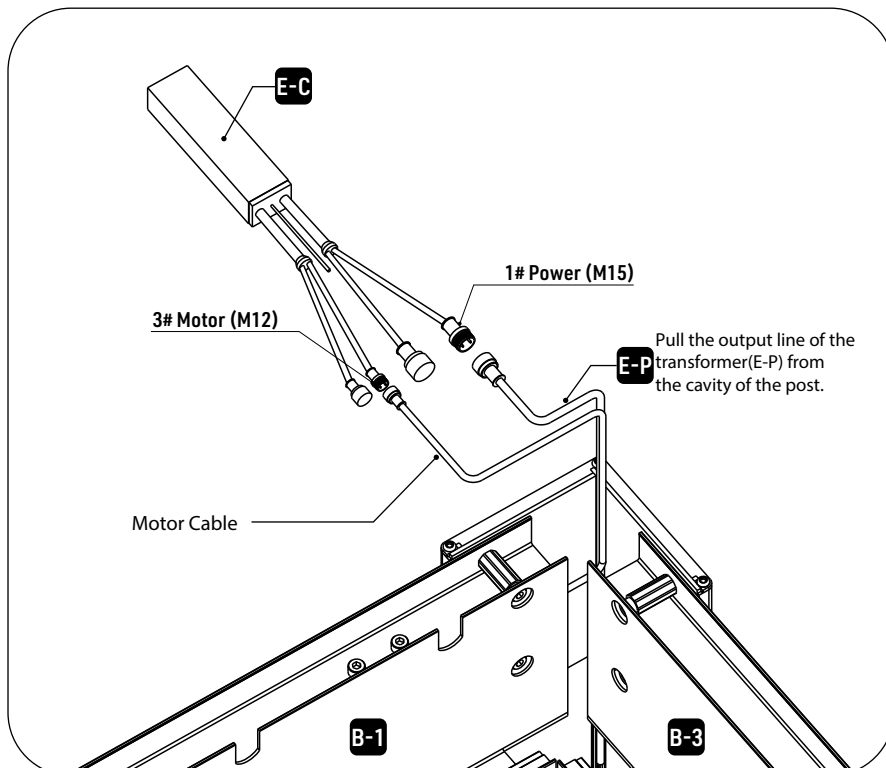
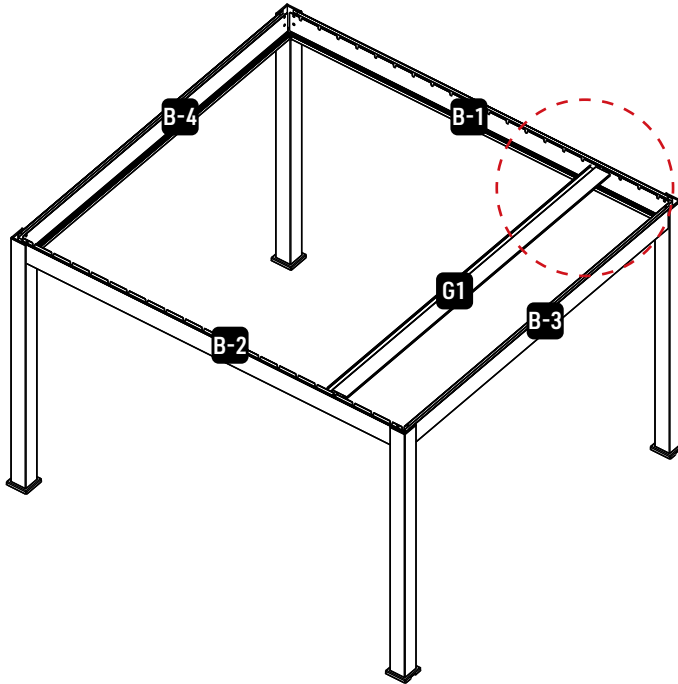
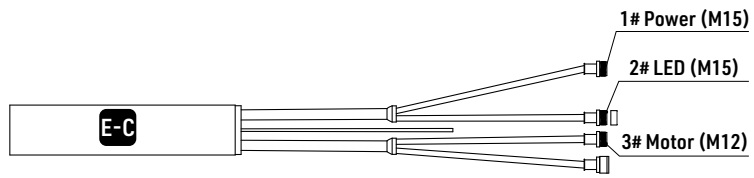

Step 5

5.3

Connect the input cable of the transformer with the extension cable(not supplied), then plug in the power.

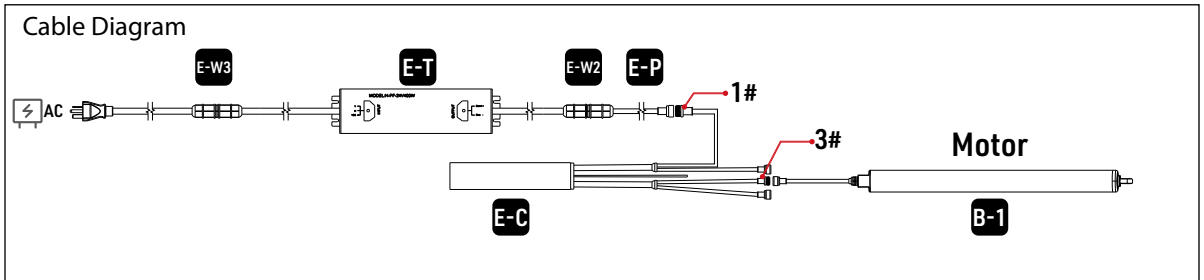
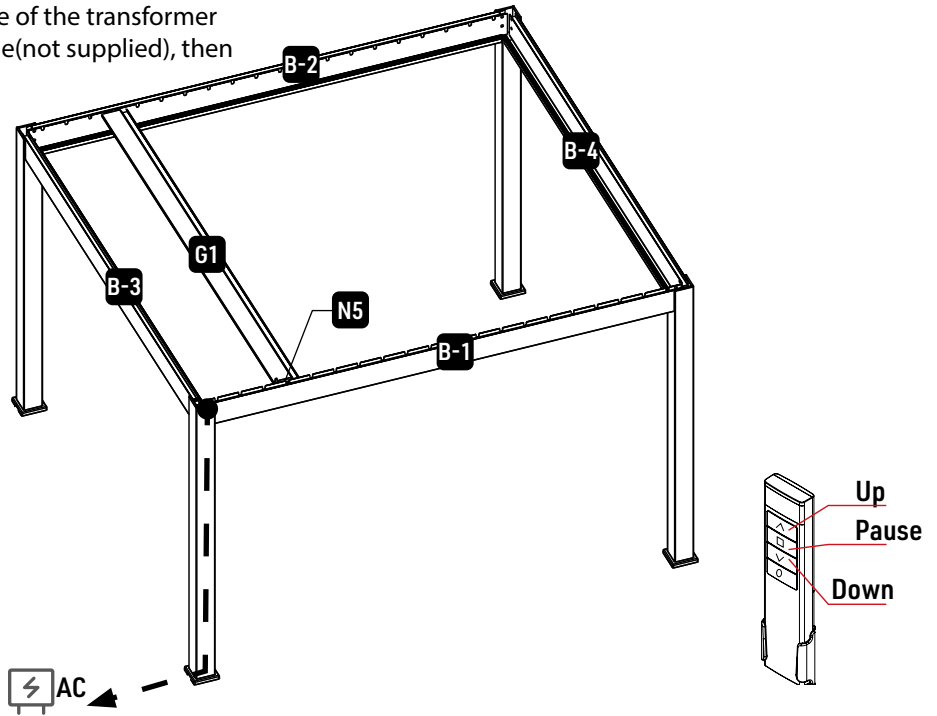

Please pair the controller with the remote in accordance with the diagram and steps below.

- 1. Press the UP Button on the remote, hold this button for 3-5 seconds until the indicator becomes solid.
- 2. Plug in the power while press the UP button, when a slight vibration appears on the main louver, it means the remote and motor are paired.

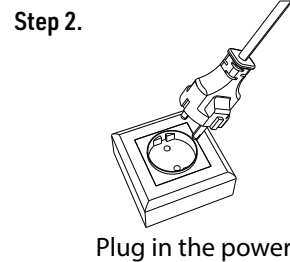
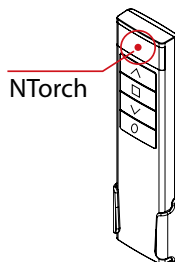
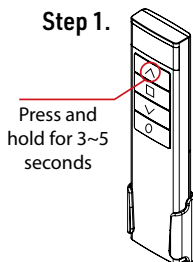

Step 5

5.4

After the completion of pairing, please use the remote to test the rotation of the louvre, then rotate the louvre into the horizontal position.

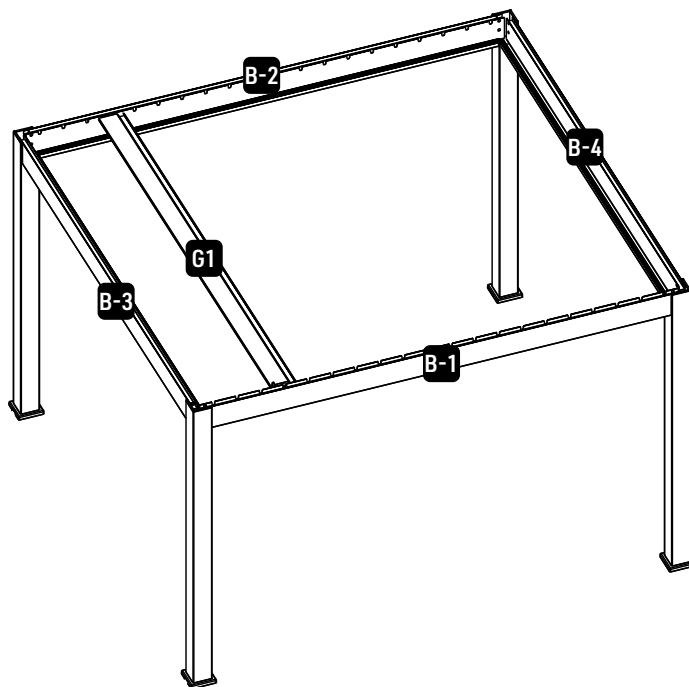
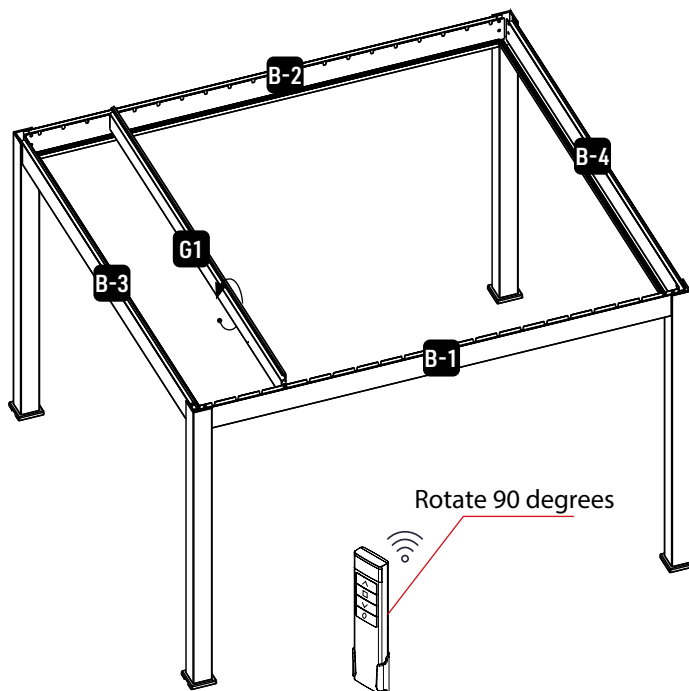

Step 5

5.5

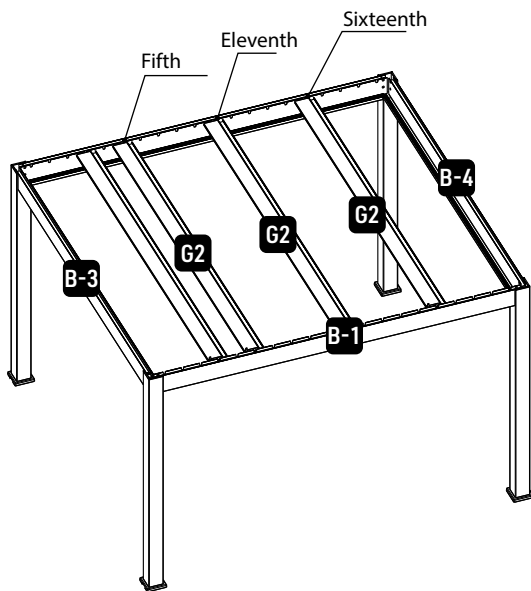

Place these LED louvres according to the position shows below.

Please refer to the below diagram to connect the cable end on the outside of louvre cover with the water-proof connector(EW-4) .

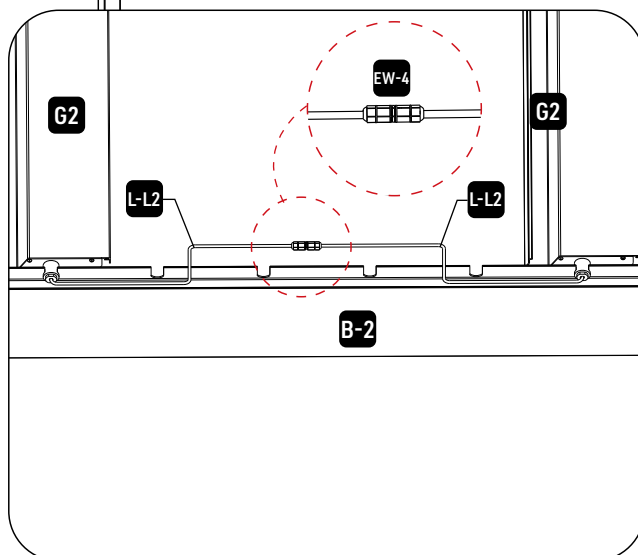
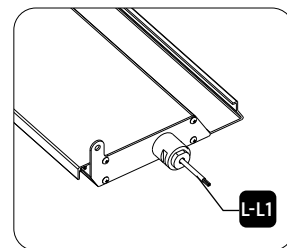
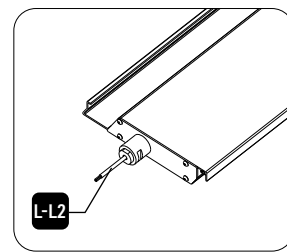
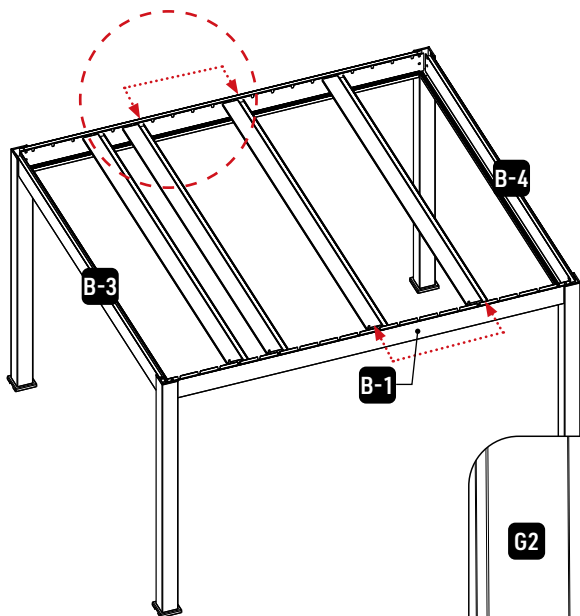

Step 5

5.6

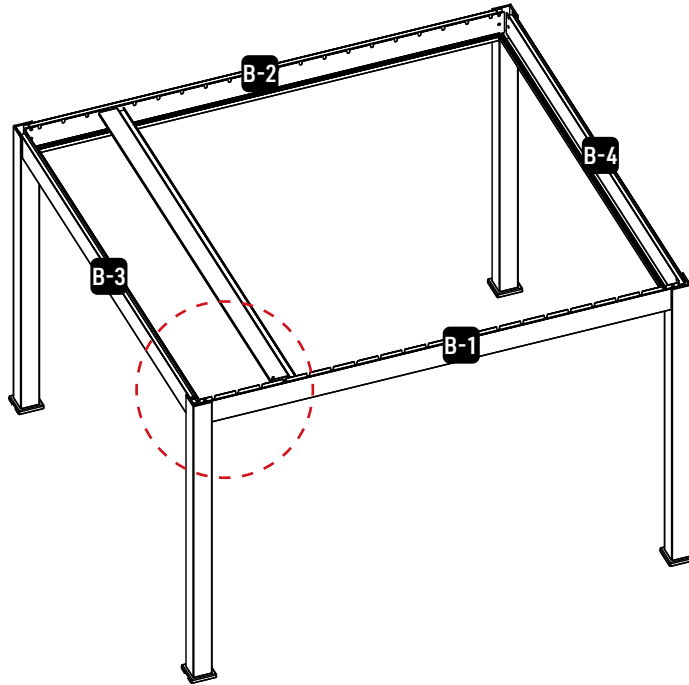
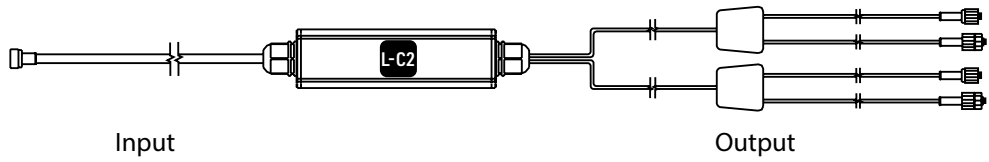

Place the LED controller into the cavity of the post as the diagram shows below.

Connect the input end of L-C2 with the 2# of the controller(E-C) .

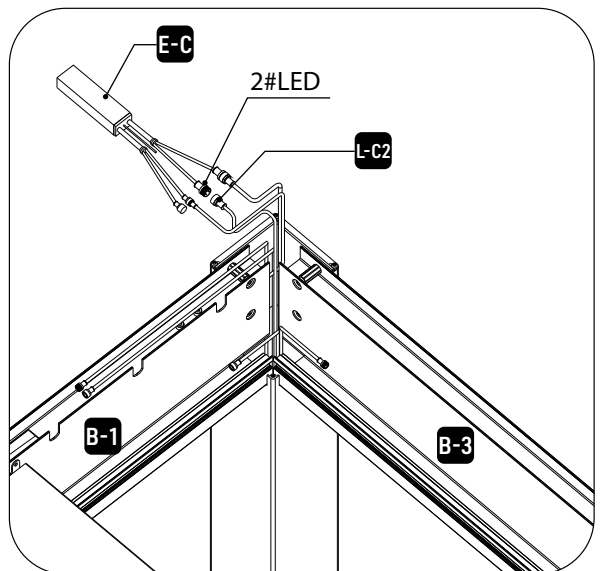
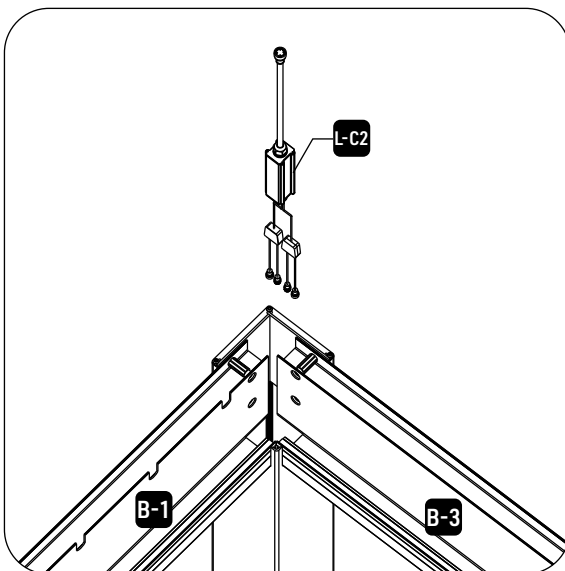

Step 5

5.6

For the output end of the LED controller, place one cable on the beam and pull the other cable from the notch of the beam.

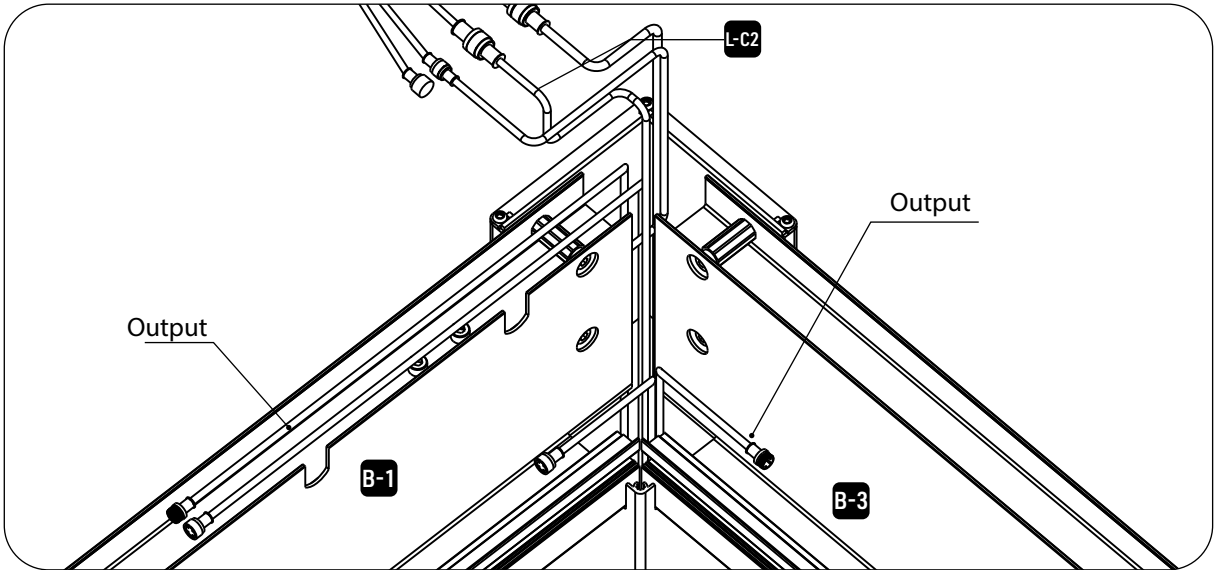

- Please connect one end of the L-L2 (on the 16st louvre's cover) with the extension line of the L-CL by using the EW-4;

Then do the same connection for the other end of the L-L2 as the diagram shows below.

- The 5th louvre should be close to the beam of B-1;
then connect the cable outside the louvre cover with the L-L1.

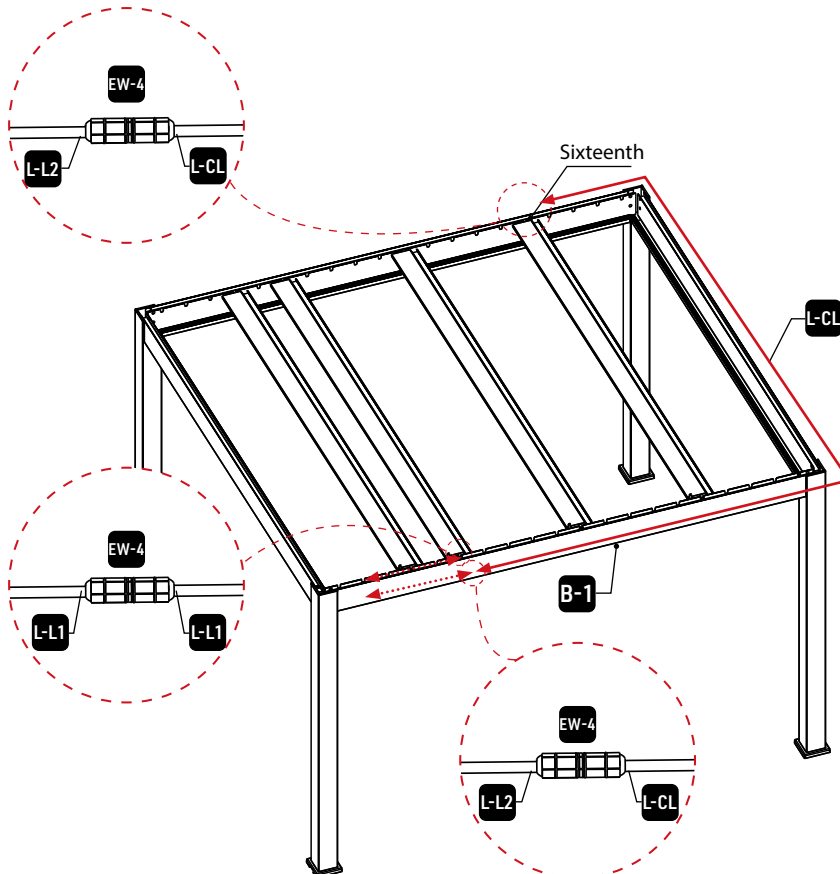

Step 5

5.7

Connect the output end of the LED controller with the belt.

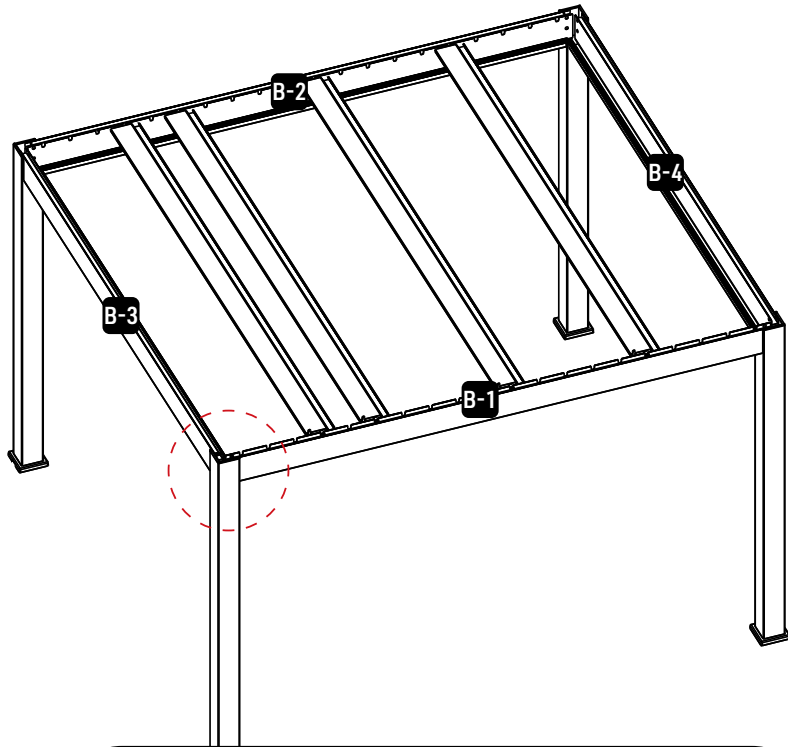

Please refer to the diagram below to do the connection.

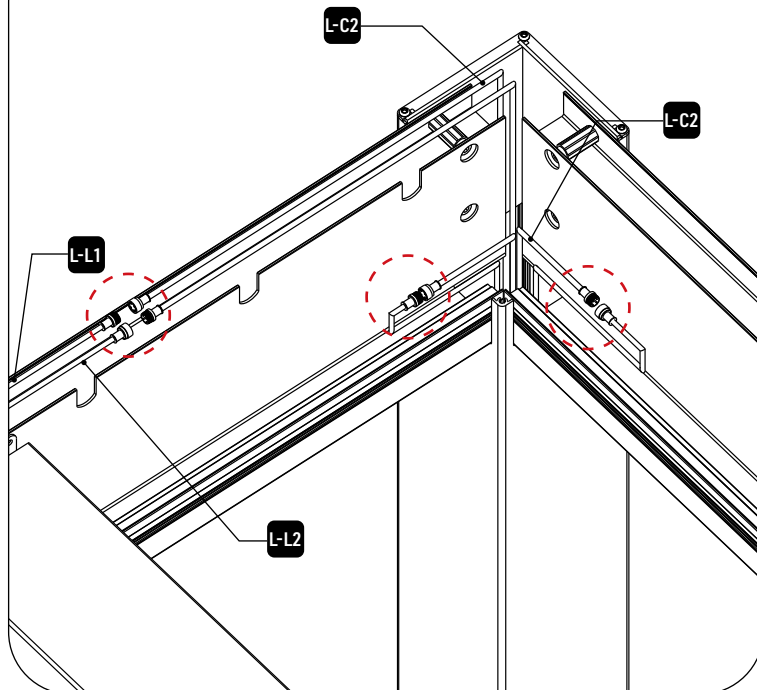

Step 5

5.8

Connect the belt of the beams.

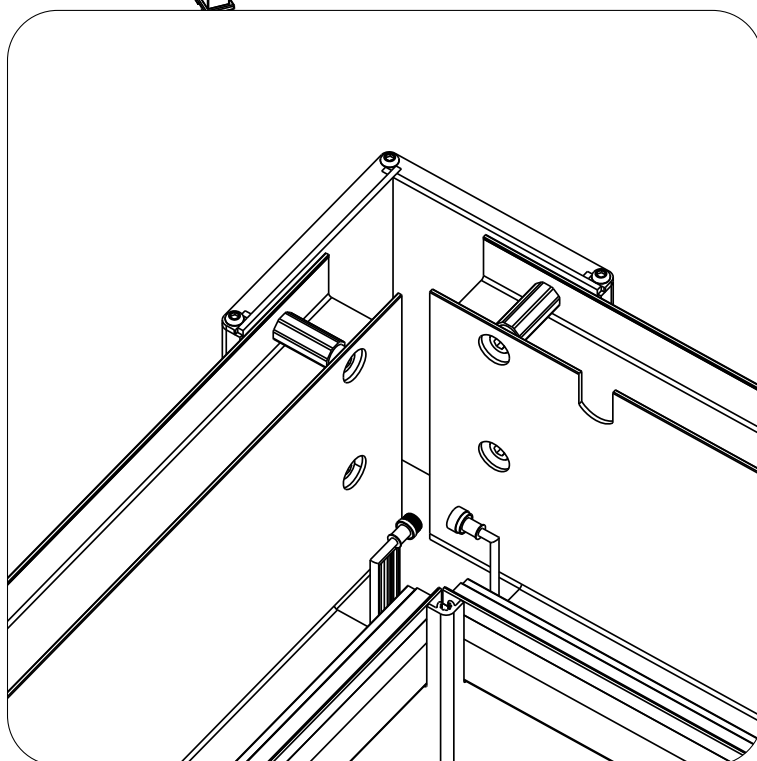
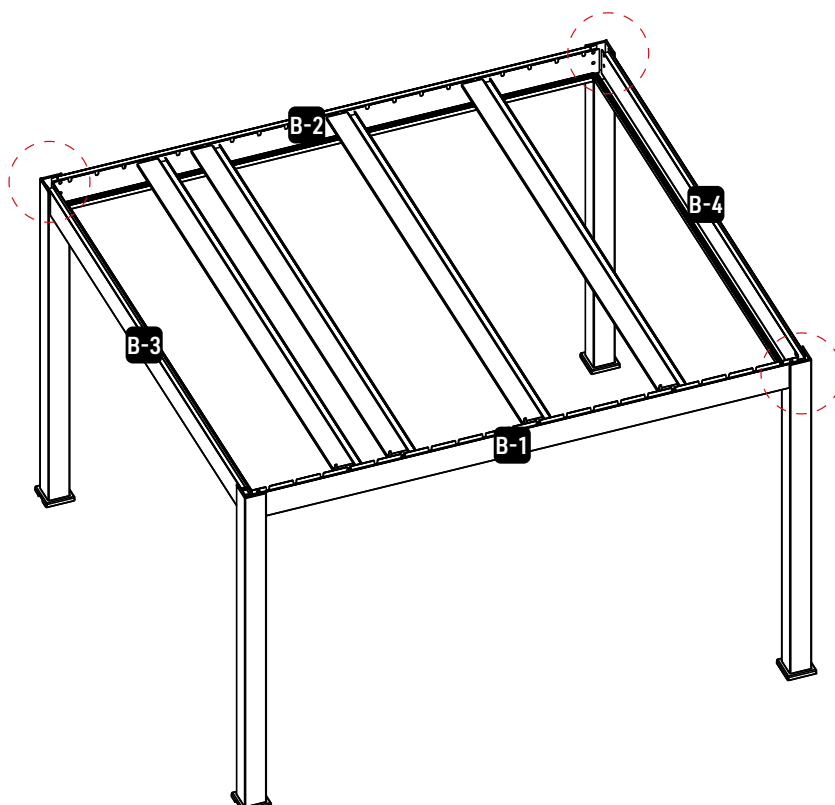

Step 5

5.9

The remote controller(E-C) has the functions below:

- Control the ON and OFF of the LED
- Control the rotation of the louvre

If you need to control the LED color, please download the APP below.

LED color control can only be available when you have access to WIFI



Tuya Smart

Tuya APP network connection

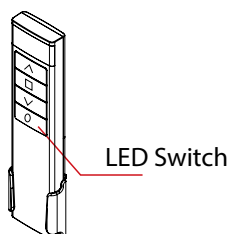

If the LED cannot be connected when powered on, please reset the controller of the LED.

Repeat power on and off for 5 consecutive times, also clear previous network connection, enter Smart cong mode, the output LED will ash 10 times.

Step 5

5.10

After connecting all cables and adjusting of LED strip, louver rotation, please put the Controller(E-C) into the cavity of the beam(B-1) as the diagram shows below.

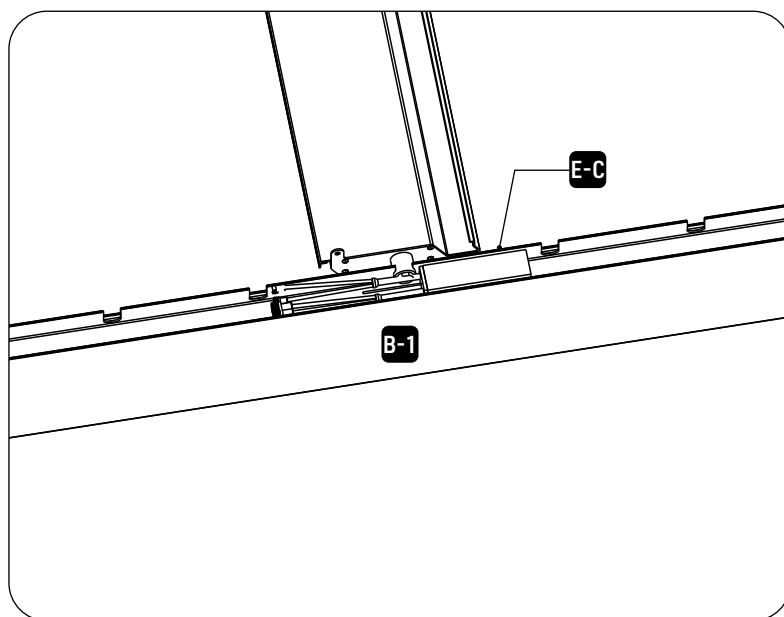
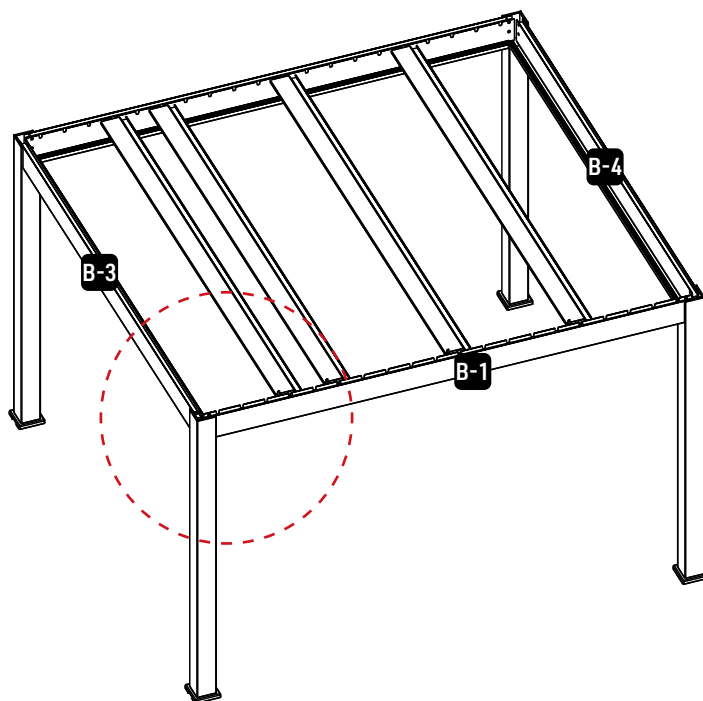







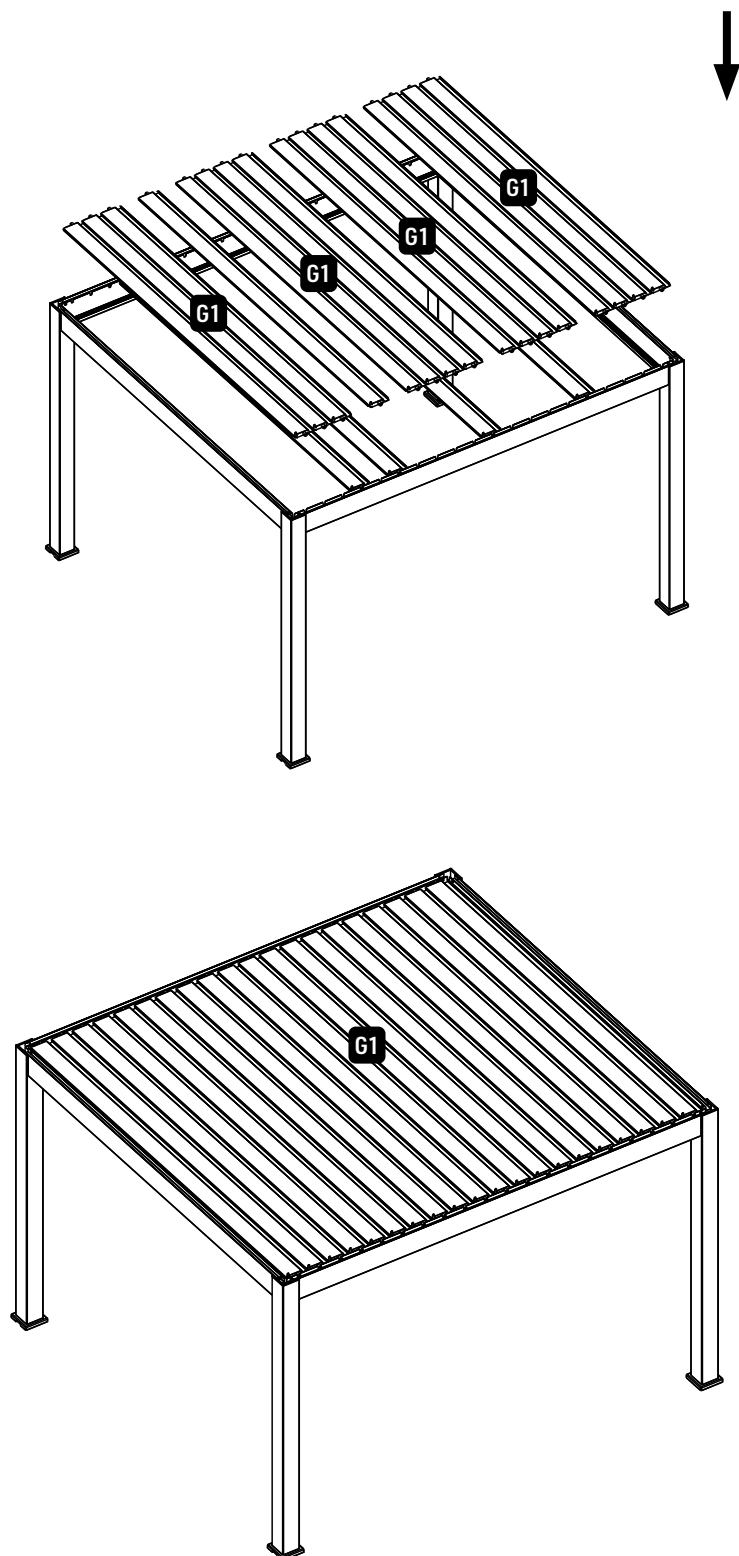

Step 6



6.1

Place the rest louvres.



Step 6

REF	PICTURE	QTY
N13	 lock nut	20
N14	 plastic nut	20
N15		40
N16	 6x20  4mm	20
N19	 5x60  PH2	32
N20	 10x80	16
N21		4

REF	PICTURE	QTY
F-1		1
D-1		2
D-2		2

6.2

Install the connecting bar.

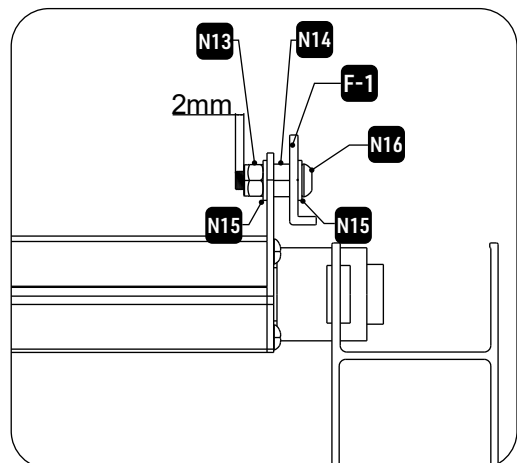
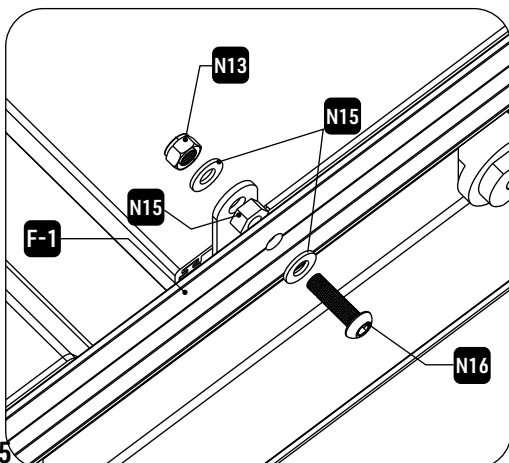
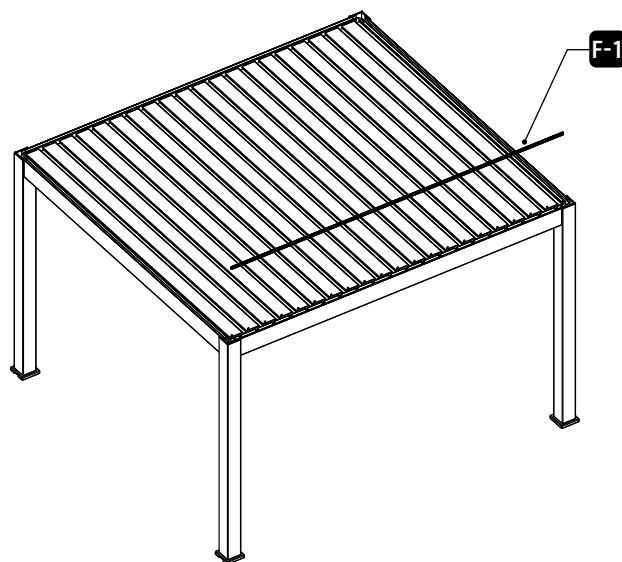

Step 6

6.4

Install the cover onto the beam.

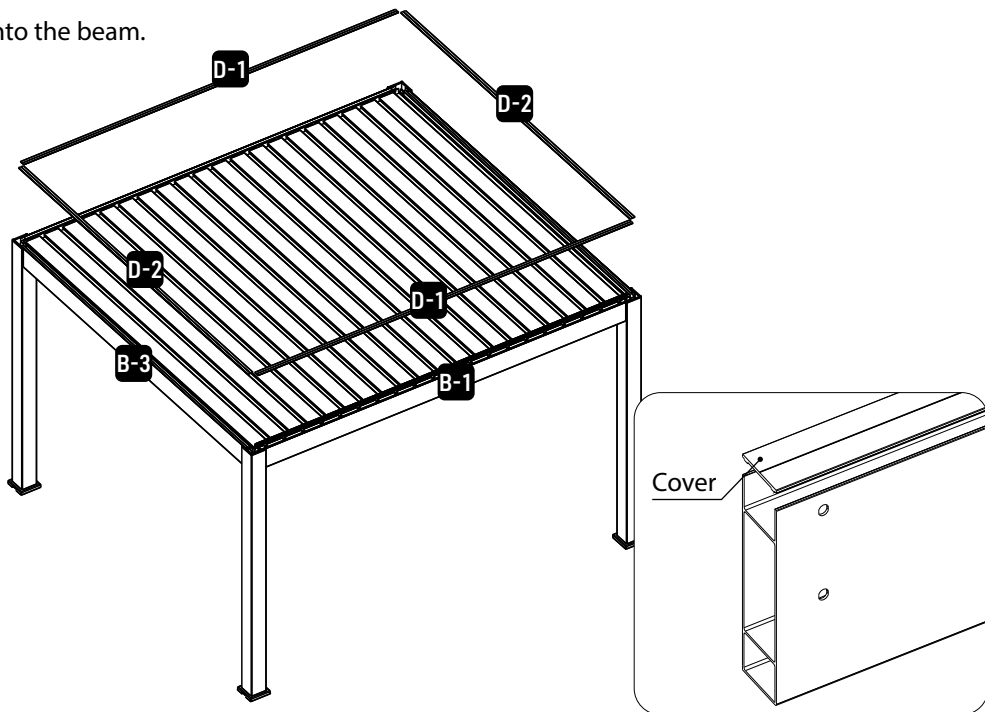

Use screws to fix the cover onto the beam.

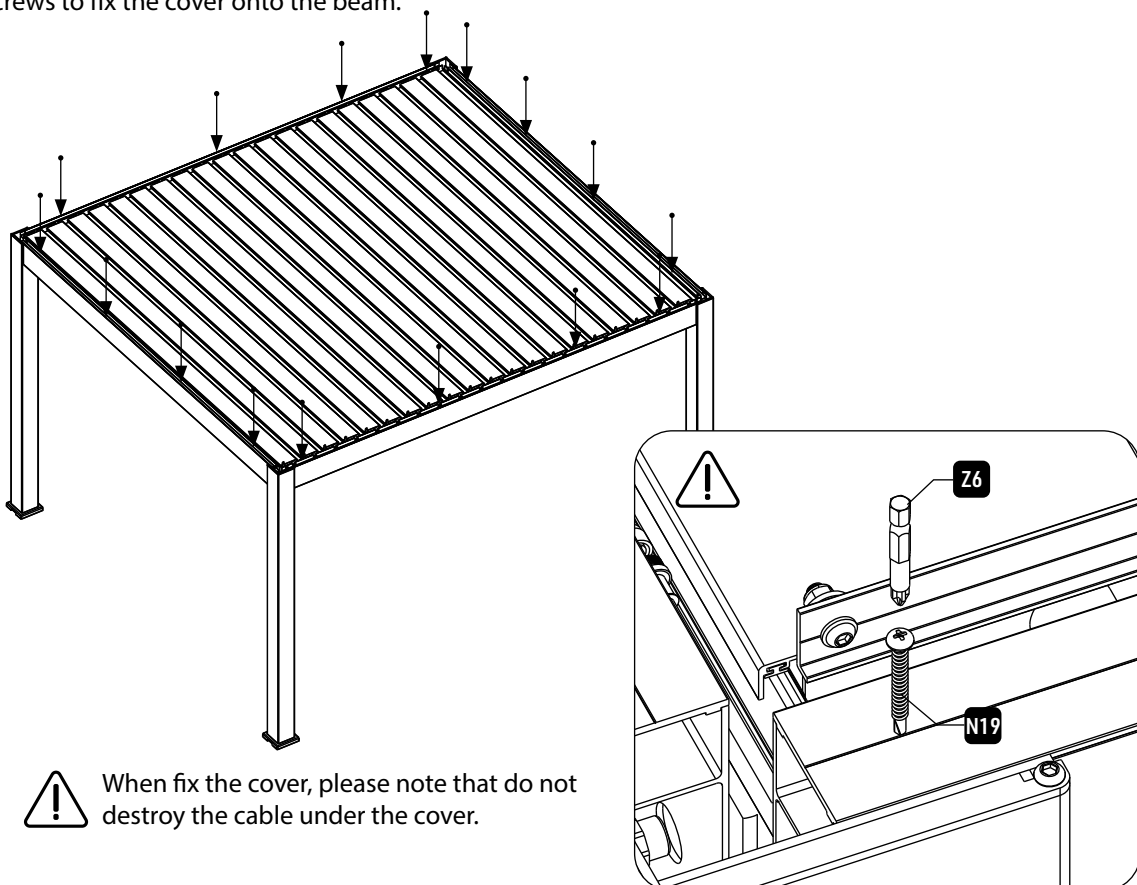

 When fix the cover, please note that do not destroy the cable under the cover.

Step 6

6.5

Install the cover of the post.

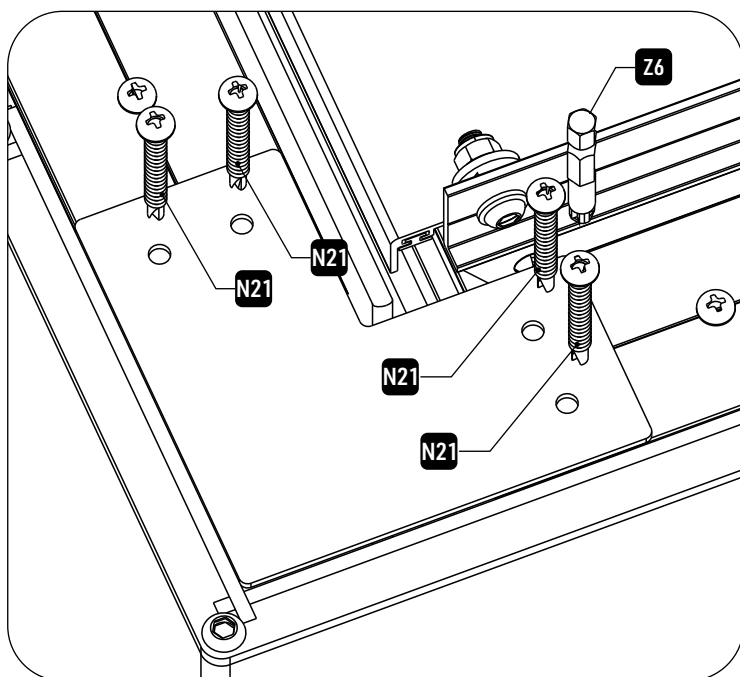
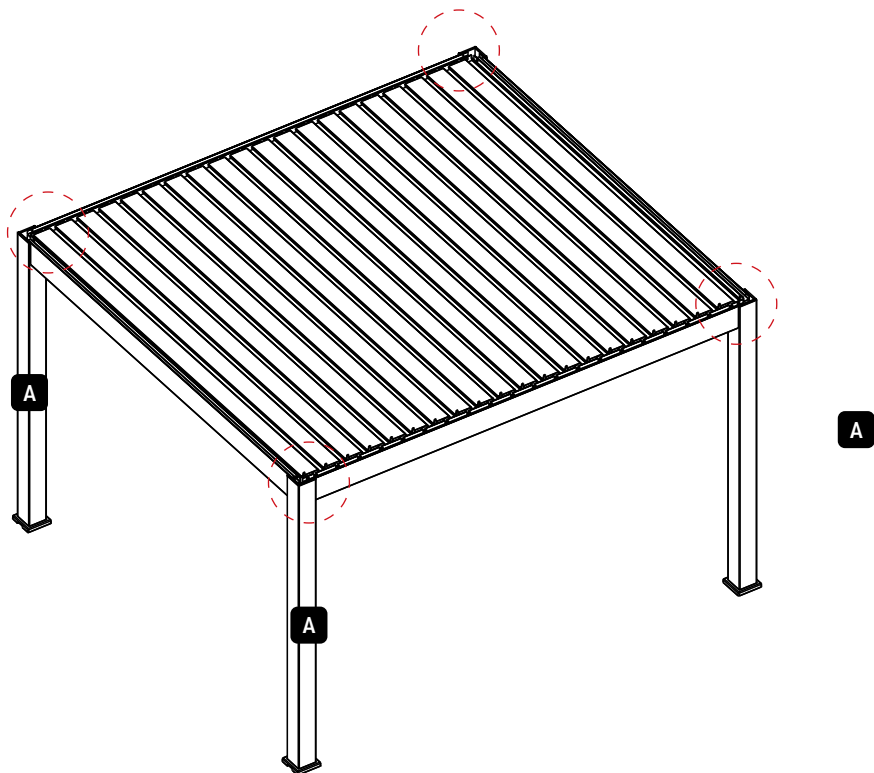

Step 6

6.6

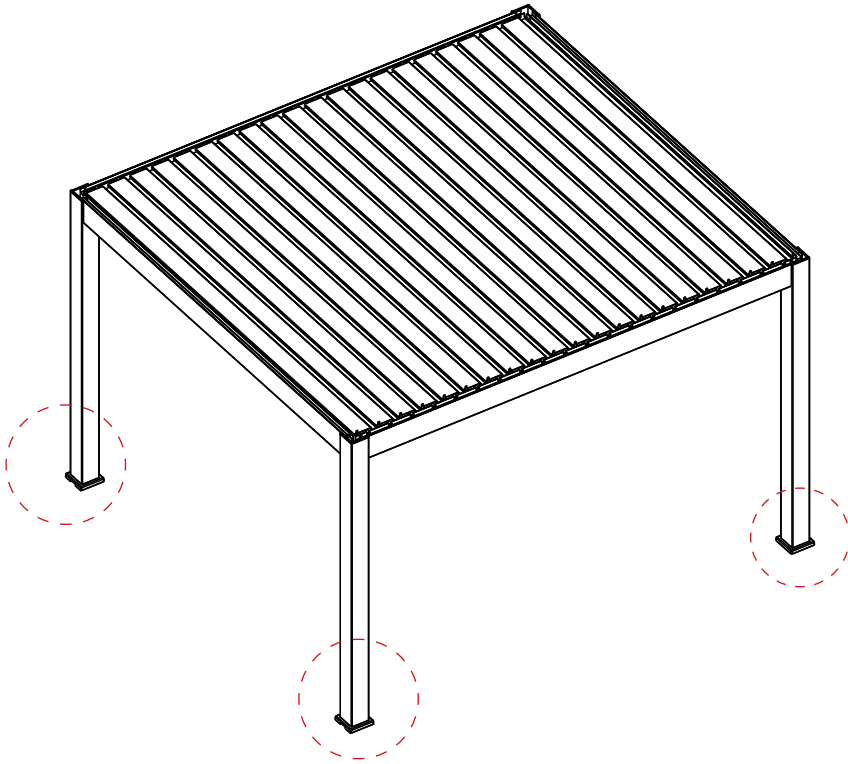

Please check all footing dimension are correct, then fix all base plates.

