

1230ES

MAST LIFT

JLG
reachingout™

Performance

Platform Height – Elevated	12 ft	3.66 m
Platform Capacity	500 lb	227 kg
Lift Time*	12 sec.	
Lower Time*	12 sec.	
Maximum Drive Height	Full Height	
Weight	1,765 lb	800.6 kg
Drive Speed		
Lowered	3 mph	4.8 kmph
Elevated	0.5 mph	0.8 kmph
Gradeability	25%	
Turning Radius		
Inside	5 in.	13 cm
Outside	4 ft 10 in.	1.46 m

*Lift and lower times shown are approximate.

Standard Specifications

Power Source

Charger	20 Amp Automatic (120V/240V – 50/60 HZ)
Batteries	4 x 6V 220 amp-hr
Drive	24V Electric, 8 hp (6kW)

Tires

- Standard 318 x 100 Non-Marking Solid

Brakes

- Electric, Friction (On Drive Wheels)

Hydraulic System

- Capacity 1.88 gal. (71 L)

Standard Features

- Industry leading duty cycles
- Controls and electrical system common with ES Series scissor lift
- Joystick with fully proportional lift and drive
- All-steel platform deck and rails
- Saloon-style entry gate
- Standard 110 V AC wiring to platform
- Corner tool tray
- Automatic traction control
- Steel swing-out battery doors with heavy duty hinges
- Mechanical Pothole Protection System
- All motion alarm
- Tilt alarm and light
- Battery condition indicator
- Horn
- Hourmeter
- Powder paint coating
- Lanyard attachment points
- Integrated lifting and tie-down points
- Machine can be lifted by forks from either side
- Pressure check port



Accessories & Options

- Flashing amber beacon
- 900W – AC Inverter/charge

1230ES

MAST LIFT



Dimensions

All dimensions are approximate.

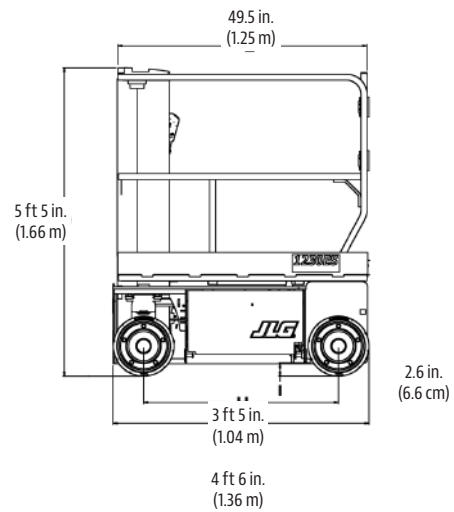
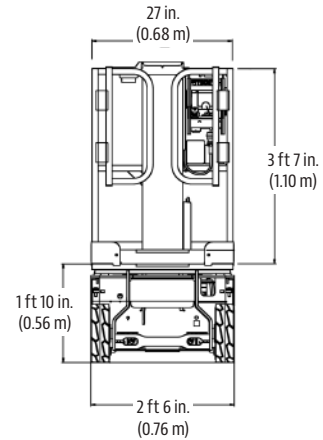
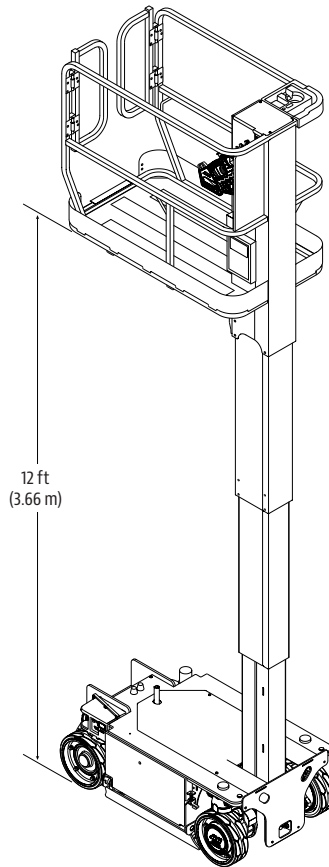

The JLG "1 & 5" Warranty

We provide coverage for one (1) full year, and cover all specified major structural components for five (5) years. Due to continuous product improvements, we reserve the right to make specification and/or equipment changes without prior notification. This machine meets or exceeds applicable ANSI and CSA requirements based on machine configuration as originally manufactured for intended applications. Please reference the serial number plate on the machine for additional information.

Part No.: 3131309
R1219_A92.20
Printed in USA



JLG Industries, Inc.
1 JLG Drive
McConnellsburg, PA 17233-9533
Telephone 717-485-5161
Toll-free in US 877-JLG-LIFT
Fax 717-485-6417
www.jlg.com

An Oshkosh Corporation Company