

# ES SERIES

ELECTRIC SCISSOR LIFTS



## Performance

Platform Height–Elevated		
2632ES	25 ft 6 in.	7.77 m
2646ES	26 ft	7.92 m
3246ES	31 ft 9 in.	9.68 m
Platform Capacity		
2632ES (Indoor Only)	800/500 lb <sup>1</sup>	363/227 kg
2646ES (Indoor & Outdoor)	1,000/500 lb <sup>2</sup>	454/227 kg
3246ES (Indoor & Outdoor)	1,000/700 lb <sup>3</sup>	454/318 kg
Capacity on Platform Extension	250 lb	113 kg
Number of Occupants		
2632ES	2 - Indoor	0 - Outdoor
2646ES	2 - Indoor	2 - Outdoor
3246ES	2 - Indoor	1 - Outdoor
Lift/Lower Time		
2632ES	33/37 seconds	
2646ES	45/50 seconds	
3246ES	55/62 seconds	
Maximum Drive Height	Fully Elevated	
Weight*		
2632ES	4,635 lb	2,103 kg
2646ES/ 3246ES	4,975 lb	2,257 kg
Ground Bearing Pressure		
2632ES	90 psi	6.32 kg/cm <sup>2</sup>
2646ES/ 3246ES	87 psi	6.11 kg/cm <sup>2</sup>
Drive Speed–Elevated	0.5 mph	0.8 km/h
Drive Speed–Lowered		
2632ES	2.75 mph	4.43 km/h
2646ES/ 3246ES	2.50 mph	4.00 km/h
Gradeability	25%	
Tilt Rating - Side to Side		
2632ES	1.5 degrees - Indoor	N/A - Outdoor
2646ES	1.5 degrees - Indoor	2.0 degrees - Outdoor
3246ES	2.0 degrees - Indoor	2.0 degrees - Outdoor
Fore and Aft	3.0 degrees	
Turning Radius (Inside)	Zero	
Turning Radius (Outside)		
2632ES	81 in.	2.06 m
2646ES/3246ES	95 in.	2.41 m

\* Certain options or country standards will increase weight.

<sup>1</sup> 2632ES - 800 lb restricted to 20' (indoor); 500 lb unrestricted (indoor)

<sup>2</sup> 2646ES - 1000 lb unrestricted (indoor); 500 lb unrestricted (outdoor)

<sup>3</sup> 3246ES - 1000 lb restricted to 26' (indoor); 700 lb unrestricted (indoor/outdoor)

## Standard Specifications

### Power Source

Batteries	4x6V, 220 amp-hr	
Charger	20 Amp Automatic	
Drive	24V Electric	8hp

### Hydraulic Reservoir

• Capacity		
2632ES	1.25 gal.	4.73 L
2646ES/3246ES	1.7 gal.	6.4 L
• Pump		
	Fixed Displacement Gear	

### Tires

• Tire Size/Type	16 x 5 in. Non-Marking Solid
------------------	------------------------------



### Brakes

- Electric/Friction

## Standard Features

- Proportional Controls
- Industry Leading Duty Cycles
- Self Closing Gate
- Battery Condition Indicator
- Fold-Down Guard Rails
- 110V-AC Receptacle in Platform
- Slide-Out Battery Trays
- Automatic Traction Control (ATC)
- All Motion Alarm
- 20 Amp Automatic SCR Charger
- Horn
- Hourmeter
- Manual Descent Pull Cable
- Tilt Alarm and Light
- Lanyard Attach Points
- Movable, Removable Platform Control
- Powder-Coated
- Console with Rail Mounting Bracket
- Nickel Plated Pins
- Lubrication Free Scissor Arm Bushings
- Scissor Maintenance Prop
- Mechanized Pothole Protection
- Machine Tie Downs
- Fork Lift Pockets
- 36 in. (91 cm) Roll-Out Deck Extension<sup>3</sup>
- 50 in. (1.27 m) Roll-Out Deck Extension<sup>4</sup>
- Four 6V, 220 Amp-Hour Deep Cycle Batteries
- Load Sensing System

3. 2632ES. 4. 2646ES and 3246ES.

## Accessories & Options

- Flashing Amber Beacon
- 245 Amp-Hour Batteries
- 900W Inverter
- Lifting Lugs
- UL® EE Rating<sup>5</sup>
- Platform Padding
- Platform Padding with Proximity Switches
- 220 Amp-Hour AGM Batteries<sup>6</sup>
- Special Hydraulic Oils
- SkySense™
- Accessory Packages:
  - Electrician's Package
  - Plumber's Package
  - JLG® Workstation
  - Panel Carrier Accessory
  - Pipe Rack Accessory
  - Plant Maintenance Package

5. Not available with AGM Batteries. 6. Not available on EE rated units.

Additional options and accessories available via JLG Aftermarket.

# ES SERIES

ELECTRIC SCISSOR LIFTS



## Dimensions

All dimensions are approximate.

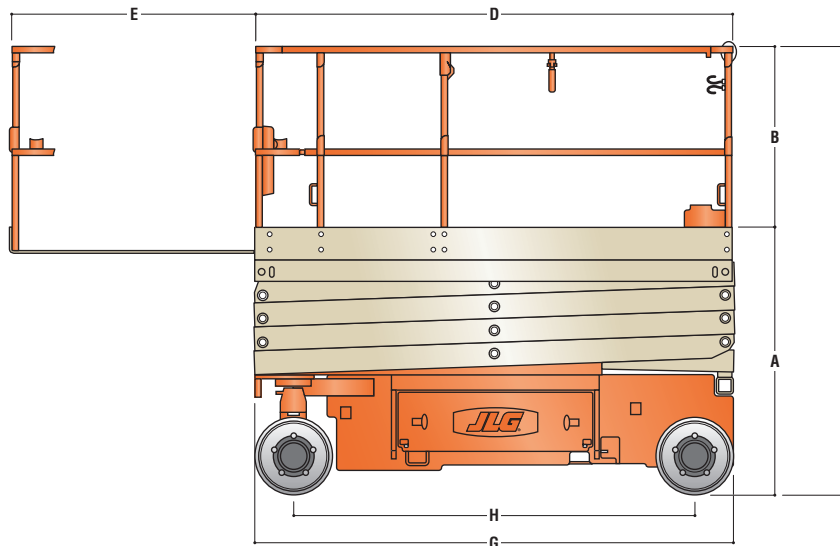
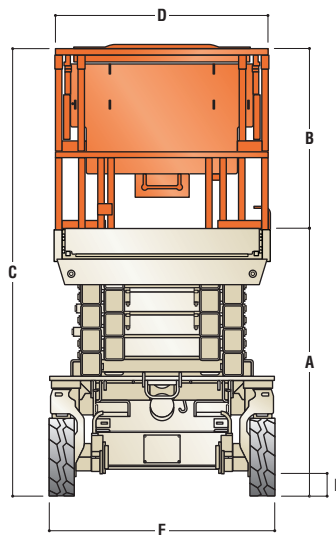

### A. Platform Height—Lowered

2632ES	48.5 in.	1.23 m
2646ES	49.5 in.	1.26 m
3246ES	49.5 in.	1.26 m

### B. Platform Railing Height

ES Series	43.3 in.	1.10 m
-----------	----------	--------

### C. Overall Height—Rails Lowered

2632ES	6 ft 4.5 in.	1.94 m
2646ES/3246ES	6 ft 5.5 in.	1.97 m

### D. Platform Size

2632ES	30 x 90.5 in.	0.76 x 2.3 m
2646ES/3246ES	44 x 98.5 in.	1.12 x 2.5 m

### E. Platform Extension

2632ES	35.5 in.	0.9 m
2646ES/3246ES	50 in.	1.27 m

### F. Overall Width

2632ES	32 in.	81 cm
2646ES/3246ES	46 in.	1.17 m

### G. Overall Length

2632ES	7 ft 6.5 in.	2.3 m
2646ES/3246ES	8 ft 2.5 in.	2.5 m

### H. Wheelbase

2632ES	6 ft 2 in.	1.88 m
2646ES/3246ES	6 ft 10 in.	2.09 m

### I. Ground Clearance

2632ES	3.5 in.	8.8 cm
2646ES/3246ES	5 in.	12.7 cm

## The JLG "1 & 5" Warranty

We provide coverage for one (1) full year, and cover all specified major structural components for five (5) years. Due to continuous product improvements, we reserve the right to make specification and/or equipment changes without prior notification. This machine meets or exceeds applicable ANSI and CSA requirements based on machine configuration as originally manufactured for intended applications. Please reference the serial number plate on the machine for additional information.

Part No.: 3131580  
R1219\_A92.20  
Printed in USA



JLG Industries, Inc.  
1 JLG Drive  
McConnellsburg, PA 17233-9533  
Telephone 717-485-5161  
Toll-free in US 877-JLG-LIFT  
Fax 717-485-6417  
[www.jlg.com](http://www.jlg.com)

An Oshkosh Corporation Company