

INDEX	PAGE(S)
<b>Under the work surface</b>	<b>138 - 139</b>
Preconfigured Models . . .	140 - 143
Componentes . . . . .	144 - 152
Accessories . . . . .	153
<b>Over the work surface</b>	<b>154</b>
Preconfigured Models . . .	155 - 159
Componentes . . . . .	160 - 164
Accessories . . . . .	165 - 181

## WS / EW WORKBENCH

Whether you need a basic workbench consisting of two legs and a top, or a more specialized, bench either stationary or mobile, you will find a solution for every application. You will love the versatility of our workbenches and their ability to evolve along with your business needs by simply adding one of the many easy-to-install accessories available. You also have a choice of multiple work surface dimensions for each of the surfaces offered, which includes painted steel, stainless steel, laminated wood, Acrylic/PVC laminate, and dissipative tops. Rousseau is your one-stop solution for an easier life!

**CUSTOMIZE YOUR WS / EW WORKBENCH WITH THE MYMODEL-R ONLINE CONFIGURATOR**

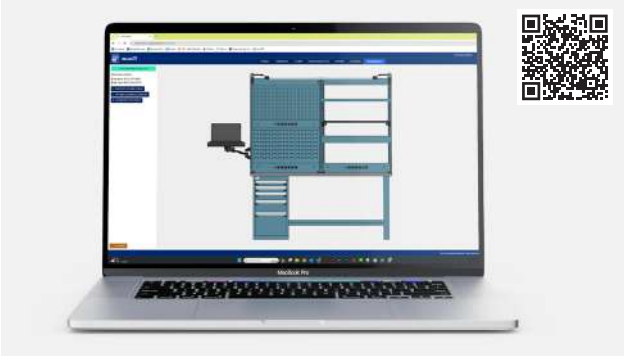

## DISTINCTIVE FEATURES

**WORK SURFACES**  
Choose from our different work surfaces for specific applications

**LEGS**  
"Inverted hat" shaped top part provides excellent rigidity  
Optional power supply available

**MOBILE WORKSTATIONS**  
Many of our workbenches can be made mobile to better meet your needs

**DRAWERS**  
Drawers fitted with a precision ball-bearing slide system  
Multiple drawer and unit heights available

**DOORS**  
Doors close and secure the underside of the work surface in the solid and polycarbonate versions

LG3101C

## GENERAL DIMENSIONS

### HEIGHTS AVAILABLE



NOTES: The total height shown includes a 1 3/4"-thick top, [see page 144](#). Extensions are available for additional heights, [see page 149](#).

### WIDTHS AND DEPTHS AVAILABLE

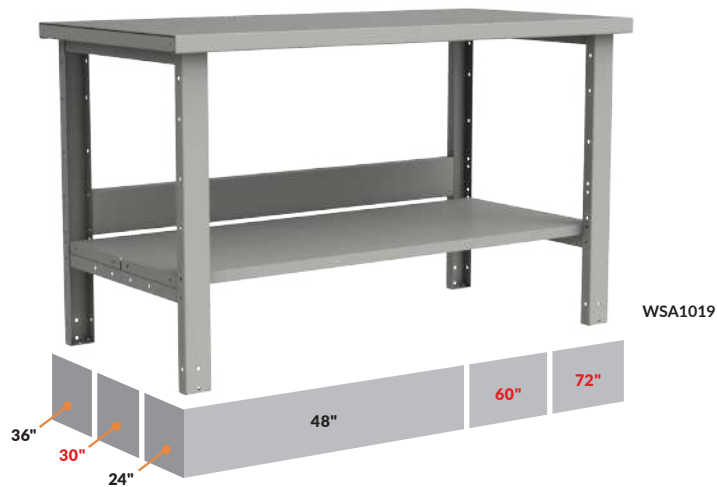

NOTE: Popular dimensions are shown in red.

# PRECONFIGURED MODELS

## BASIC WORKBENCHES

### BASIC WORKBENCH WITH STRINGER



WSA2031

- 1 top of your choice
- 2 legs, 27"D x 32"H
- 1 stringer

- The mobile model (35"H total) includes the following additional accessories:
  - 2 pairs of caster adapters for legs
  - 1 pair of 4" rigid casters
  - 1 pair of 4" swivel casters with total-lock brake
  - 1 footrest

NOTE: The legs on mobile models are 28"H

DIMENSIONS				TYPE OF TOP		
W	D	H	PAINTED STEEL	LAMINATED HARDWOOD	PLASTIC LAMINATE*	ACRYLIC/PVC
60"	30"	34"	WS_1031	WS_2031	WS_3031*	WS_9031
72"	30"	34"	WS_1035	WS_2035	WS_3035*	WS_9035
72"	36"	34"	WS_1039	WS_2039	WS_3039*	WS_9039

To order: Complete the product number as follows:

A for a stationary workbench, W for a mobile workbench, e.g., WSA2031.

NOTE: \* The plastic laminate top is white by default. See page 144 for another option.

### WORKBENCH WITH SHELVES



WSA2019

- 1 top of your choice
- 2 legs, 27"D x 32"H
- 2 shelves, 12"D
- 1 stringer

- The mobile model (35"H total) includes the following additional accessories:
  - 2 pairs of caster adapters for legs
  - 1 pair of 4" rigid casters
  - 1 pair of 4" swivel casters with total-lock brake

NOTE: The legs on mobile models are 28"H

DIMENSIONS				TYPE OF TOP		
W	D	H	PAINTED STEEL	LAMINATED HARDWOOD	PLASTIC LAMINATE*	ACRYLIC/PVC
60"	30"	34"	WS_1019	WS_2019	WS_3019*	WS_9019
72"	30"	34"	WS_1023	WS_2023	WS_3023*	WS_9023
72"	36"	34"	WS_1027	WS_2027	WS_3027*	WS_9027

To order: Complete the product number as follows:

A for a stationary workbench, W for a mobile workbench, e.g., WSA2019

NOTE: \* The plastic laminate top is white by default. See page 144 for another option.

### CLOSED WORKBENCH



WSA2070

- 1 top of your choice
- 2 legs, 27"D x 32"H
- 1 sliding door with L3 lock
- 2 side panels and 1 back panel
- 3 shelves, 12"D
- 2 leg crossbars

- The mobile model (35"H total) includes the following additional accessories:
  - 2 pairs of caster adapters for legs
  - 1 pair of 4" rigid casters
  - 1 pair of 4" swivel casters with total-lock brake

NOTE: The legs on mobile models are 28"H

DIMENSIONS				TYPE OF TOP		
W	D	H	PAINTED STEEL	LAMINATED HARDWOOD	PLASTIC LAMINATE*	ACRYLIC/PVC
60"	30"	34"	WS_1070	WS_2070	WS_3070*	WS_9070
72"	30"	34"	WS_1071	WS_2071	WS_3071*	WS_9071
72"	36"	34"	WS_1072	WS_2072	WS_3072*	WS_9072

To order: Complete the product number as follows:

A for a stationary workbench, W for a mobile workbench, e.g., WSA2070

NOTE: \* The plastic laminate top is white by default. See page 144 for another option.



## ADJUSTABLE WORKBENCH



WSN2KH001E

- 1 top of your choice
- 2 open legs for lift mechanism, 27"D x 28"H
- 1 lift mechanism
- Anti-slip leveling glides
- Height adjustable from 30" to 42"
- 1 stringer, 17"H
- Compatible with riser shelves
- Load capacity: 825lb.

DIMENSIONS			TYPE	TYPE OF TOP			
W	D	H		PAINTED STEEL	LAMINATED HARDWOOD	PLASTIC LAMINATE*†	DISSIPATIVE**†
48"	30"	30" to 42"	Electric	WSN1HH001E	WSN2HH001E	WSN3HH001E*†	WSN4HH001E**†
			Crank	WSN1HH001M	WSN2HH001M	WSN3HH001M*†	WSN4HH001M**†
60"	30"	30" to 42"	Electric	WSN1KH001E	WSN2KH001E	WSN3KH001E*†	WSN4KH001E**†
			Crank	WSN1KH001M	WSN2KH001M	WSN3KH001M*†	WSN4KH001M**†
72"	30"	30" to 42"	Electric	WSN1LH001E	WSN2LH001E	WSN3LH001E*†	WSN4LH001E**†
			Crank	WSN1LH001M	WSN2LH001M	WSN3LH001M*†	WSN4LH001M**†



An EW Bench Frame can only be installed on the electric version.

To use a bench frame with a crank lifting system, refer to the ElevaTek section on page 182.

NOTES: These models cannot be made mobile.

\* Load capacity: 725lb.

† The plastic laminate top is white by default. See page 144 for another option.

\*\* Models with dissipative tops include an ESD protection kit for workstations, see page 181.

## DESK WITH CLOSED LEGS



WSA2043

- 1 top of your choice
- 1 back panel
- 2 closed legs, 27"D x 28"H
- 1 shelf, 12"D

DIMENSIONS				TYPE OF TOP		
W	D	H		PAINTED STEEL	LAMINATED HARDWOOD	PLASTIC LAMINATE*
60"	30"	30"	WSA1043	WSA2043	WSA3043*	WSA9043
72"	30"	30"	WSA1044	WSA2044	WSA3044*	WSA9044

NOTES: These models cannot be made mobile.

\* The plastic laminate top is white by default. See page 144 for another option.

## CLOSED DESK WITH CLOSED LEGS



WSA2170

- 1 top of your choice
- 1 back panel
- 2 closed legs, 27"D x 32"H
- 3 shelves, 12"D
- 2 leg crossbars
- 1 front finishing panel
- 1 back finishing panel
- 1 sliding door with L3 lock

DIMENSIONS				TYPE OF TOP		
W	D	H		PAINTED STEEL	LAMINATED HARDWOOD	PLASTIC LAMINATE*
60"	30"	34"	WSA1170	WSA2170	WSA3170*	WSA9170
72"	30"	34"	WSA1171	WSA2171	WSA3171*	WSA9171
72"	36"	34"	WSA1172	WSA2172	WSA3172*	WSA9172

NOTES: These models cannot be made mobile.

\* The plastic laminate top is white by default. See page 144 for another option.

## OPEN DOUBLE WORKBENCH



WSA2904

- 2 tops of your choice
- 3 legs, 27"D x 32"H
- 2 stringers
- 4 steel shelves, 12"D
- 1 shelf adapter for common leg
- 1 stringer extension for common leg

DIMENSIONS				TYPE OF TOP		
W	D	H		PAINTED STEEL	LAMINATED HARDWOOD	PLASTIC LAMINATE*
8'(2 x 48")	30"	34"	WSA1902	WSA2902	WSA3902*	WSA9902
10'(2 x 60")	30"	34"	WSA1904	WSA2904	WSA3904*	WSA9904
12'(2 x 72")	30"	34"	WSA1906	WSA2906	WSA3906*	WSA9906

NOTES: These models cannot be made mobile.

\* The plastic laminate top is white by default. See page 144 for another option.

# PRECONFIGURED MODELS

## CLOSED DOUBLE WORKBENCH



WSA2973

- 2 tops of your choice
- 3 legs, 27"D×32"H
- 2 side panels and 2 back panels
- 4 steel shelves, 12"D
- 1 shelf adapter for common leg
- 2 sliding doors with L3 locks
- 2 side extensions for common leg

DIMENSIONS			TYPE OF TOP			
W	D	H	PAINTED STEEL	LAMINATED HARDWOOD	PLASTIC LAMINATE*	ACRYLIC/PVC
8' (2×48")	30"	34"	WSA1971	WSA2971	WSA3971*	WSA9971
10' (2×60")	30"	34"	WSA1973	WSA2973	WSA3973*	WSA9973
12' (2×72")	30"	34"	WSA1975	WSA2975	WSA3975*	WSA9975

NOTES: These models cannot be made mobile.

\* The plastic laminate top is white by default. See page 144 for another option.

## WORKBENCH WITH COMPACT CABINET



LG2101C

- 1 top of your choice
- 1 leg, 27"D×32"H
- 1 L Compact Cabinet with 4" base
- The mobile model (35"H total) includes the following additional accessories:
  - 1 pair of 4" rigid casters
  - 1 pair of 4" swivel casters with total-lock brake
  - 1 footrest
- 1 integrated lock-in mechanism for drawers
- 1 base for casters for compact cabinet
- 1 pair of caster adapters for legs

NOTES: The legs on mobile models are 28"H.

Cabinet base not included with mobile model.

DIMENSIONS			TYPE OF TOP			
W	D	H	PAINTED STEEL	LAMINATED HARDWOOD	PLASTIC LAMINATE*	ACRYLIC/PVC
60"	30"	34"	L__1101C	L__2101C	L__3101C*	L__9101C
72"	30"	34"	L__1102C	L__2102C	L__3102C*	L__9102C
72"	36"	34"	LH1103C	LH2103C	LH3103C*	LH9103C

To order: Complete the product number as follows:

**G** for a stationary workbench with 21"D cabinet (for 30"D workbenches only)

**H** for a stationary workbench with 27"D cabinet (for 30"D and 36"D workbenches only)

**J** for a mobile workbench

NOTE: \* The plastic laminate top is white by default. See page 144 for another option.

## WORKBENCH WITH TWO COMPACT CABINETS



LG2201C

- 1 top of your choice
- 2 L Compact Cabinets with 4" base

DIMENSIONS			TYPE OF TOP			
W	D	H	PAINTED STEEL	LAMINATED HARDWOOD	PLASTIC LAMINATE*	ACRYLIC/PVC
60"	30"	34"	L__1201C	L__2201C	L__3201C*	L__9201C
72"	30"	34"	L__1202C	L__2202C	L__3202C**	L__9202C
72"	36"	34"	LH1203C	LH2203C	LH3203C*	LH9203C

To order: Complete the product number as follows:

**G** for a stationary workbench with 21"D cabinet (for 30"D workbenches only)

**H** for a stationary workbench with 27"D cabinet (for 30"D and 36"D workbenches only)

NOTES: These models cannot be made mobile.

\* The plastic laminate top is white by default. See page 144 for another option.



27" cabinets are recommended for mobile workbenches or workbenches with an EW bench frame.



27" cabinets are recommended for mobile workbenches or workbenches with an EW bench frame.

## WORKBENCH WITH SUSPENDED COMPACT CABINET



LG2001

- 1 top of your choice
- 2 legs, 27"D×32"H
- 1 stringer
- 1 L Compact Cabinet, 21"D
- 1 pair of cabinet attachment bars

DIMENSIONS			TYPE OF TOP			
W	D	H	PAINTED STEEL	LAMINATED HARDWOOD	PLASTIC LAMINATE*	ACRYLIC/PVC
60"	30"	34"	LG1001	LG2001	LG3001*	LG9001
72"	30"	34"	LG1002	LG2002	LG3002*	LG9002
72"	36"	34"	LG1003	LG2003	LG3003*	LG9003

NOTES: These models cannot be made mobile.  
 Load capacity is limited to 50lb. per drawer in a suspended cabinet with RA70 attachment bars.  
 \* The plastic laminate top is white by default. See page 144 for another option.

## DESK WITH COMPACT CABINET



LG2107

- 1 top of your choice
- 1 closed leg, 27"D×28"H
- 1 L Compact Cabinet, 21"D

DIMENSIONS			TYPE OF TOP		
W	D	H	PAINTED STEEL	LAMINATED HARDWOOD	PLASTIC LAMINATE*
60"	30"	30"	LG1107	LG2107	LG3107*
72"	30"	30"	LG1108	LG2108	LG3108*
72"	36"	30"	LH1109	LH2109	LH3109*

NOTE: These models cannot be made mobile.  
 \* The plastic laminate top is white by default. See page 144 for another option.



27" cabinets are recommended for mobile workbenches or workbenches with an EW bench frame.

## WORKBENCH WITH HEAVY-DUTY DRAWERS



R5XDG-3004

- 1 laminated hardwood top
- 2 legs, 27"D×32"H
- 1 drawer unit
- 2 steel shelves
- 1 stringer

DIMENSIONS			TYPE OF TOP
W	D	H	LAMINATED HARDWOOD
48"	30"	34"	R5XDG-3004

NOTE: These models cannot be made mobile.



R5WH5-2007

- 1 laminated hardwood top
- 1 leg, 27"D×32"H
- 1 heavy-duty cabinet (with drawer compartments)

DIMENSIONS			TYPE OF TOP
W	D	H	LAMINATED HARDWOOD
60"	30"	34"	R5WH5-2007

NOTE: These models cannot be made mobile.

# COMPONENTS

## WORK SURFACES

### RESISTANT ACRYLIC / PVC LAMINATE TOP



WS08



- Ideal for assembly stations and for applications using solvents, oils or other chemical products
- Thickness: 1½"
- Featuring softened edges, with ⅛" PVC edge banding around the entire perimeter for a clean and durable finish
- Color: gray
- Excellent chemical resistance (can be in prolonged contact with a substance)
- Superior impact resistance compared with standard laminate tops
- Attractive appearance

### STAINLESS STEEL TOP

WS12



- Top for industrial, maintenance, repair and assembly applications, or for when solvents, oils and other chemical products are used
- Thickness: 1¾". 12ga steel
- #4 brushed finish, attractive appearance
- 2 steel crossbars for attaching legs
- 3 wood crossbars (2" × 4") for attaching cabinets and other accessories
- Can be reinforced and soundproofed with a WS75 wood filler
- Excellent corrosion resistance
- Excellent chemical resistance (can be in prolonged contact with a substance)

NOTE: RC35 tops are also compatible with stationary workstations (not recommended for mobile applications), [see pages 12-13](#).

### PAINTED STEEL TOP

WS10



- Top for industrial, maintenance, repair and assembly applications
- Thickness: 1¾"
- 2 steel crossbars for attaching legs
- 3 wood crossbars (2" × 4") for attaching cabinets and other accessories
- Can be reinforced and soundproofed with a WS75 wood filler
- Excellent impact resistance
- Powder painted steel

NOTE: RC37 tops are also compatible with stationary workstations (not recommended for mobile applications), [see pages 12-13](#).

### LAMINATED HARDWOOD TOP

WS14



- Top for general industrial applications
- Thickness: 1¾"
- Made from varnished hardwood slats
- 90° radius front edge for extra comfort
- High impact resistance
- Attractive appearance

### PLASTIC LAMINATED TOP



WS16



- Top for general use. Ideal for assembly stations, quality control and packaging
- Thickness: 1½"
- Featuring softened edges, with ⅛" PVC edge banding around the entire perimeter for a clean and durable finish
- Colors: Default is white. For another color, add -BA for black or -GB for gray to the end of the product number, e.g., WS16-6024A-BA for a black top
- Attractive appearance
- Easy to clean



### DISSIPATIVE TOP



WS17



- Top for electronics tasks. Ideal for electronics inspection and assembly stations
- Thickness: 1½"
- Featuring softened edges, with ⅛" PVC edge banding around the entire perimeter for a clean and durable finish
- Color: white
- Attractive appearance
- Easy to clean
- Dissipates electrical charges that can damage electronic components
- The resistance point to point and point to ground is between 10<sup>6</sup>Ω and 10<sup>9</sup>Ω
- Complies with the ESD-S4.1-1997 standard

NOTE: Grounding accessories are sold separately, [see page 181](#).

DIMENSIONS		TYPE OF TOPS					
W	D	ACRYLIC/PVC LAMINATE	PAINTED STEEL	STAINLESS STEEL	LAMINATED HARDWOOD	PLASTIC LAMINATE	DISSIPATIVE
36"	24"				WS14-3624A	WS16-3624-__	
	30"				WS14-3630A	WS16-3630-__	
48"	24"	WS08-4824	WS10-4824	WS12-4824	WS14-4824A	WS16-4824-__	WS17-4824
	30"	WS08-4830	WS10-4830	WS12-4830	WS14-4830A	WS16-4830-__	WS17-4830
	36"	WS08-4836	WS10-4836	WS12-4836	WS14-4836A	WS16-4836-__	WS17-4836
60"	24"	WS08-6024	WS10-6024	WS12-6024	WS14-6024A	WS16-6024-__	WS17-6024
	30"	WS08-6030	WS10-6030	WS12-6030	WS14-6030A	WS16-6030-__	WS17-6030
	36"	WS08-6036	WS10-6036	WS12-6036	WS14-6036A	WS16-6036-__	WS17-6036
72"	24"	WS08-7224	WS10-7224	WS12-7224	WS14-7224A	WS16-7224-__	WS17-7224
	30"	WS08-7230	WS10-7230	WS12-7230	WS14-7230A	WS16-7230-__	WS17-7230
	36"	WS08-7236	WS10-7236	WS12-7236	WS14-7236A	WS16-7236-__	WS17-7236

NOTES: Please refer to technical guide W54 for load capacities based on the configuration. 21"D cabinets are compatible with 24"D WS10 / 12 tops.  
 21"D cabinets are not compatible with 30"D and 36"D WS10 / 12 tops.  
 27"D cabinets are compatible with 30"D and 36"D WS10 / 12 tops.

### STEEL TOP CROSSBAR

### WS11



- Painted steel
- Installs in the center of a steel top (WS10 or WS12) for extra reinforcement
  - To add an extra leg
  - To add another cabinet
  - Will reduce deflexion (will not increase capacity)

PRODUCT NO.	W x D
WS11-24	6" x 24"
WS11-30	6" x 30"
WS11-36	6" x 36"

### WOOD FILLER FOR STEEL TOP

### WS75



- Made from wooden crossbars
- Inserts into WS10 and WS12 steel tops for soundproofing
- Increases sturdiness of steel tops
- Enables accessories to be installed under the work surface
- Depths available: 24", 30" and 36"
- To order: Specify the depth required

PRODUCT NO.	WIDTH
WS75-48-__	48"
WS75-60-__	60"
WS75-72-__	72"

### SIDE BRACKETS FOR TOP

### RA73



- Load capacity: 500lb. per pair, 1,000lb. for four
- Compatible with all cabinet depths
- Compatible with all types of top
- Galvanized steel

PRODUCT NO.	
RA73-02	One pair
RA73-04	Two pairs

### BACK OR SIDE STOPS

### WS18 / WS98



- Painted steel: WS18
- Stainless steel: WS98
- Can be installed on back or sides depending on top dimensions
- Compatible with all WS tops
- Height: 5" Extends above top by approx. 3/4"
- To order: Specify the type of steel required, e.g., WS18-2405

PRODUCT NO.	LENGTH
WS__-2405	24"
WS__-3005	30"
WS__-3605	36"
WS__-4805	48"
WS__-6005	60"
WS__-7205	72"

NOTE: Not compatible with E uprights.

# COMPONENTS

## STRUCTURAL COMPONENTS

### OPEN LEG

### WS20

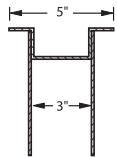

- Three basic heights available: 28", 32" and 34"
- WS21 extensions can be added if required
- "Inverted hat" shaped top part provides excellent rigidity
- A second WS24 leg crossbar can be added for installation of WS50 / WS56 shelves
- Can be closed with a WS62 side panel
- To add a power strip with two 15A outlets, add -20 to the product number
- To add a power strip with one 15A outlet and two USB ports (1 A, 1 C), add -22 to the product number

PRODUCT NO.	D×H	WORK SURFACE DEPTH
WS20-2128-__	21"×28"	24" and 30"
WS20-2132-__	21"×32"	24" and 30"
WS20-2134-__	21"×34"	24" and 30"
WS20-2728-__	27"×28"	30" and 36"
WS20-2732-__	27"×32"	30" and 36"
WS20-2734-__	27"×34"	30" and 36"

### CLOSED LEG

### WS25

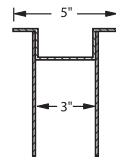

- Fulfills aesthetic requirements of certain work environments
- Three basic heights available: 28", 32" and 34"
- "Inverted hat" shaped top part provides excellent rigidity
- One closed side. There are no holes on the front or exterior side
- There are fixing zones for accessories on the interior side
- A second WS24 leg crossbar can be added for installation of WS50 / WS56 shelves
- To add a power strip with two 15A outlets, add L-20 to the product number for the left leg and R-20 for the right leg
- To add a power strip with one 15A outlet and two USB ports (1 A, 1 C), add L-22 to the product number for the left leg and R-22 for the right leg

PRODUCT NO.	D×H	WORK SURFACE DEPTH
WS25-2128-__	21"×28"	24" and 30"
WS25-2132-__	21"×32"	24" and 30"
WS25-2134-__	21"×34"	24" and 30"
WS25-2728-__	27"×28"	30" and 36"
WS25-2732-__	27"×32"	30" and 36"
WS25-2734-__	27"×34"	30" and 36"

NOTES: Compatible with WS26 leveling glides, [see page 149](#).  
Not compatible with WS21 leg extensions, [see page 149](#).

### STRINGER

### WS22



- Attaches between the two legs at the rear to strengthen the structure
- Available in standard widths that correspond to work surface widths
- Can act as a back for shelves under the work surface

PRODUCT NO.	WIDTH	WORK SURFACE WIDTH
WS22-4805	39"	48"
WS22-6005	51"	60"
WS22-7205	63"	72"

### LEG CROSSBAR

### WS24



- Provides space for a second row of shelves under the work surface
- Can be mounted to a WS20 open leg or WS25 closed leg
- To add a power strip with two 15A outlets, add -20 to the product number
- To add a power strip with one 15A outlet and two USB ports (1 A, 1 C), add -22 to the product number

PRODUCT NO.	LEG DEPTH
WS24-21-__	21"
WS24-27-__	27"

### FLOOR ANCHORING HARDWARE KIT

### WS80



- For anchoring legs to the ground
- Includes four bolts for concrete floors

PRODUCT NO.  
WS80

## WALL-MOUNTED OPEN LEG

WS95



- Load capacity: 500lb. per leg, 1,000lb. per pair (if wall and wall anchoring are of sufficient strength)
- Anchoring hardware not provided by Rousseau
- Intended for 24"D, 30"D and 36"D tops
- Compatible with RC32, RC35, RC37, WS08, WS10, WS12, WS14, WS16 and WS17 tops
- Compatible with WS18 back stops and EW uprights
- WS96 crossbars and a 12"D WS50/WS56 shelves (optional add-on) can be installed on this product

PRODUCT NO.	D×H
WS95-2428	22 <sup>5</sup> / <sub>8</sub> " × 29 <sup>7</sup> / <sub>8</sub> "

NOTE: For more information on our wall-mounted solutions: [see page 265](#).

## CORNER GUSSETS FOR LEG

WS28



- Sold in pairs
- Installs on a leg and under the work surface to reinforce the structure
- Recommended for mobile workstations with a particle board or plastic laminate top

PRODUCT NO.
WS28-01

NOTE: For load capacities for mobile workstations with gussets, please refer to technical guide W54 or contact your Customer Service representative. Not compatible with WS10 and WS12 steel tops.

## CROSSBAR FOR WALL-MOUNTED LEG

WS96



- For installation of a 12"D WS50/WS56 shelves between two WS95 wall-mounted legs

PRODUCT NO.	DEPTH
WS96-24	13 <sup>3</sup> / <sub>4</sub> "

## ADJUSTABLE FOOTREST

WS23



- Adjustable width; adjusted by sliding the inner part in or out
- Required for all mobile workstations
- Attaches to the leg crossbars or the cabinet sides to strengthen the structure

PRODUCT NO.	WIDTH ADJUSTMENT
WS23-1624	16" to 24"
WS23-2440	24" to 40"
WS23-4072	40" to 72"

FOOTRESTS AVAILABLE BASED ON CONFIGURATION	WORK SURFACE WIDTH		
	48"	60"	72"
2 legs	WS23-2440	WS23-4072	WS23-4072
1 leg and 1 L Compact Cabinet	WS23-2440	WS23-2440	WS23-4072
2 L Compact Cabinets	-	WS23-1624	WS23-2440
1 leg and 1 RA30-2427 cabinet	-	WS23-2440	WS23-4072
1 leg and 1 RA30-3027 cabinet	-	WS23-2440	WS23-2440
1 leg and 1 RA30-3624 cabinet	-	WS23-1624	WS23-2440

## STEEL SHELF

WS50 / WS56

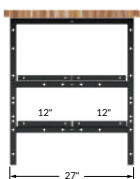
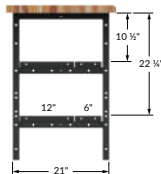

- Painted steel: WS50
- Stainless steel: WS56
- Thickness: 1<sup>1</sup>/<sub>4</sub>"
- Installs on WS24 leg crossbars or on WS96 shelf supports, [see pages 147 and 164](#)
- Shelf combinations:
  - 21"D legs: One 6"D shelf + one 12"D shelf
  - 27"D legs: Two 12"D shelves
- To order: Specify the type of steel required

PRODUCT NO.	W×D	WORK SURFACE WIDTH
WS_-4806	45" × 6"	48"
WS_-4812	45" × 12"	48"
WS_-6006	57" × 6"	60"
WS_-6012	57" × 12"	60"
WS_-7206	69" × 6"	72"
WS_-7212	69" × 12"	72"

## ADAPTER FOR STEEL SHELF

RC15



- For installation of a WS50/WS56 shelves between two RA30 or two LA30 cabinets
- For installation of a WS50 shelf between an RA30 cabinet and a WS20 leg or between an LA30 cabinet and a WS20 leg
- Installs in holes on the side of the cabinet (knockouts provided)

PRODUCT NO.	DEPTH
RC15-12	12" (one 12" or two 6" shelves)
RC15-18	18" (12" + 6" or three 6" shelves)
RC15-24	24" (two 12" or four 6" shelves)

# COMPONENTS

## SIDE PANEL

### WS62



- Installs on open legs
- Compatible with 28"H, 32"H and 34"H legs

PRODUCT NO.	D×H	LEG DEPTH
WS62-2128	20"×25"	21"
WS62-2728	26"×25"	27"

## BACK PANEL

### WS63



- Installs behind WS20 open or WS25 closed legs
- Widths available:
  - 48" (one part)
  - 60" and 72" (two parts each)
- Compatible with 28"H, 32"H and 34"H legs

PRODUCT NO.	W×H	SURFACE WIDTH
WS63-4828	39"×24"	48"
WS63-6028	51"×24"	60"
WS63-7228	63"×24"	72"

## FINISHING PANEL

### WS65 / WS66



- Front finishing panel: [WS65](#)
- Rear finishing panel: [WS66](#)
- Closes the space under a set of sliding doors on both the front and back of the workstation
- Three basic heights available: 4", 8" and 10"
- Compatible with workstations with 28"H, 32"H and 34"H closed legs
- To order: Specify the finishing panel and height required, e.g., [WS65-4808](#) for a front finishing panel 48"W×8"H

PRODUCT NO.	W×H	CLOSED LEG HEIGHT
WS__-4804	48"×4"	28"
WS__-4808	48"×8"	32"
WS__-4810	48"×10"	34"
WS__-6004	60"×4"	28"
WS__-6008	60"×8"	32"
WS__-6010	60"×10"	34"
WS__-7204	72"×4"	28"
WS__-7208	72"×8"	32"
WS__-7210	72"×10"	34"

## SLIDING DOORS

### WS60 / WS61



- Sliding doors: [WS60](#)
- Sliding polycarbonate doors: [WS61](#)
- Closes and secures the area under the work surface (standard L3 lock included)
- Compatible with workstations with 28"H, 32"H and 34"H legs
- To order: Specify the type of door required, e.g., [WS61-4828L3](#) for 39"W×24"H sliding polycarbonate doors



PRODUCT NO.	W×H	WORK SURFACE WIDTH
WS__-4828L3	39"×24"	48"
WS__-6028L3	51"×24"	60"
WS__-7228L3	63"×24"	72"



## SIDE EXTENSION FOR COMMON LEG

WS64

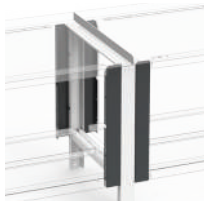

- Includes one extension at the front and one at the back
- Required for mounting WS60 sliding doors or WS63 back panels to a common leg

PRODUCT NO.	HEIGHT
WS64-0325	25"

## SHELF ADAPTER FOR COMMON LEG

WS78

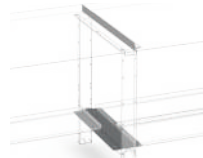

- Must be ordered to install WS50/WS56 shelves on a common leg

PRODUCT NO.	LEG DEPTH
WS78-0321	21"
WS78-0327	27"

NOTE: Not compatible with WS62 side panels.

## STRINGER EXTENSION FOR COMMON LEG

WS79



- Must be ordered to install a WS22 stringer on a common leg

PRODUCT NO.
WS79-0305

## POWER OUTLET MODULE

WS7B



- Mounts directly under a WS14 laminated hardwood or WS08 and WS16 laminate work surface
- Includes 15' power cord
- Two models available: two 15A outlets, or one 15A outlet and two USB ports (1 A, 1 C),

PRODUCT NO.	OPTIONS
WS7B-20	2 power outlets
WS7B-22	1 power outlet + 2 USB ports (1 A, 1 C),

## LEVELING GLIDES

WS26



For leg WS20/25



With leg extensions WS21

- Sold in pairs
- Adjusts the height of legs on uneven surfaces
- For use with an L Compact Cabinet, see LA74 Leveling Glide Kit, [see page 35](#)

PRODUCT NO.
WS26

## LEG EXTENSIONS / CASTER ADAPTERS

WS21



- Compatible with WS20 open legs only
- Sold in pairs
- Three basic heights available: 3", 6" and 9"
- Leg height can be adjusted with the 6"H and 9"H models
- Casters can be installed on the 3"H and 6"H models;
- Casters cannot be used with the 9"H model

PRODUCT NO.	HEIGHT	ADJUSTMENT POSSIBLE	CASTER TYPE
WS21-0306	3"	—	4" or 6"
WS21-0606	6"	Up to 3"	4" or 6"
WS21-0904	9"	Up to 6"	Not compatible

## CASTERS



\_B81-03



\_B84-03



RB8E-02

- Sold in pairs
- Three types of casters available: rigid, swivel and swivel with total-lock brake (on wheel and swivel)
- Dark gray, non-marking polyurethane tread
- Superior industrial quality
- To order: Specify the type of cabinet required (L or R), e.g., RB81-01

PRODUCT NO.	CASTER TYPE	LOAD CAPACITY	HEIGHT	
			WHEEL HEIGHT	TOTAL
_B81-01	Rigid	440 lb	4"	5½"
_B81-02	Swivel	440 lb	4"	5½"
_B81-03	Swivel with total-lock brake	440 lb	4"	5½"
_B84-01	Rigid	1100 lb	6"	7½"
_B84-02	Swivel	1100 lb	6"	7½"
_B84-03	Swivel with total-lock brake	1100 lb	6"	7½"
RB8E-02	Swivel caster directional locking kit for swivel casters (x2)			

NOTES: Not compatible with 18"W R cabinets.  
The casters install directly under an R cabinet (without base).  
An LB93 cart or LB96 base for casters is required for use with an L compact cabinet, [see page 65](#)

# COMPONENTS

## QUIET CASTERS



- Sold in pairs
- Smooth and quieter rolling
- Two types of casters available: rigid and swivel with total-lock brake (on wheel and swivel)
- Blue, hard-wearing polyurethane tread for quiet and easy maneuvering
- Superior industrial quality
- To order: Specify the type of cabinet required (L or R), e.g., RB8C-01
- Order the L version for use with WS21 caster adapters

PRODUCT NO.	CASTER TYPE	LOAD CAPACITY	HEIGHT	
			WHEEL HEIGHT	TOTAL
_B8C-01	Quiet, rigid	660 lb	4"	5 $\frac{1}{8}$ "
_B8C-03	Quiet, swivel with total-lock brake	660 lb	4"	5 $\frac{1}{8}$ "
_B8D-01	Quiet, rigid	1100 lb	6"	7 $\frac{1}{2}$ "
_B8D-03	Quiet, swivel with total-lock brake	1100 lb	6"	7 $\frac{1}{2}$ "

NOTES: Not compatible with 18"W R cabinets.  
The casters install directly under an R cabinet (without base).  
An LB93 cart or LB96 base for casters is required for use with an L compact cabinet, [see page 65](#).



**PRECONFIGURED CABINETS**

HERE ARE SOME OF OUR MOST POPULAR PRECONFIGURED CABINET MODELS FOR WORKSTATIONS

**L Compact Cabinets:**

- 27"D cabinets are required for 36"D workstations and recommended for workstations with EW bench frames and for 30"D mobile workstations
- Order LG31 hanging file bars to hang letter size (8½" × 11") or legal size (8½" × 14") files in a 12"H drawer, [see page 32](#)
- To order a key lock, add **L3** to the product number
- To add a safety hasp LP, an L50 electronic lock or an L100 smart lock to a door or to your L cabinet, [see page 31](#)



**R Heavy-Duty Cabinets:**

- The preconfigured models in this section include a 2" recessed base and a key lock on the cabinet housing
- 12"H drawers are designed to hold hanging file bars. Order RG30 or RG31 hanging file bars, [see page 298](#)
- To add a safety hasp LP, an L50 electronic lock or an L100 smart lock to a door or to your R cabinet, [see page 11](#)

**IMPORTANT**

Drawer compartments are included in all models.

To order drawers without compartments, replace the last two digits of the model number with the next even number up.

e.g., L3ABD-2851 with L3ABD-2852 without





**NUMBER OF COMPARTMENTS (LAYOUT CODE)**

DRAWER DIMENSIONS (W×D)	9"H AND HIGHER		
	3"H TO 5"H	6"H TO 8"H	
18" × 21"	9 (0206)	6 (0104)	4 (0102)
18" × 27"	9 (0206)	6 (0104)	4 (0102)
24" × 21"	12 (0308)	9 (0206)	4 (0102)
24" × 27"	20 (0316)	12 (0209)	6 (0104)
30" × 21"	24 (0518)	12 (0308)	6 (0203)
30" × 27"	25 (0420)	12 (0308)	9 (0206)





**28" H L COMPACT CABINETS - WITHOUT BASE**

				
5 DRAWERS L3ABD-2861__ 18" × 21" × 28" L3ABG-2861__ 18" × 27" × 28"	4 DRAWERS L3ABD-2871__ 18" × 21" × 28" L3ABG-2871__ 18" × 27" × 28"	3 DRAWERS L3ABD-2873__ 18" × 21" × 28" L3ABG-2873__ 18" × 27" × 28"	6 DRAWERS L3ABD-2867__ 18" × 21" × 28" L3ABG-2867__ 18" × 27" × 28"	4 DRAWERS L3ABD-2869__ 18" × 21" × 28" L3ABG-2869__ 18" × 27" × 28"

**32" H L COMPACT CABINETS - WITH 4" H BASE**

				
4 DRAWERS L3ABD-2851__C 18" × 21" × 32" L3ABG-2851__C 18" × 27" × 32"	1 DOOR / 1 AJUSTABLE SHELF L3ABD-2854__C 18" × 21" × 32" L3ABG-2854__C 18" × 27" × 32"	3 DRAWERS L3ABD-2855__C 18" × 21" × 32" L3ABG-2855__C 18" × 27" × 32"	2 DRAWERS L3ABD-2857__C 18" × 21" × 32" L3ABG-2857__C 18" × 27" × 32"	4 DRAWERS L3ABD-2859__C 18" × 21" × 32" L3ABG-2859__C 18" × 27" × 32"

**R HEAVY-DUTY CABINETS - WITH 2" H BASE**

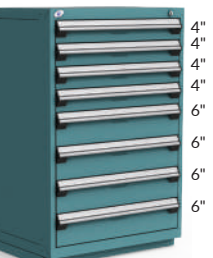
				
4 DRAWERS R5ACD-3013 24" × 21" × 32" R5ACG-3013 24" × 27" × 32"	6 DRAWERS R5ACD-3017 24" × 21" × 32" R5ACG-3017 24" × 27" × 32"	4 DRAWERS R5ADD-3015 30" × 21" × 32" R5ADG-3015 30" × 27" × 32"	4 DRAWERS R5ADD-3017 30" × 21" × 32" R5ADG-3017 30" × 27" × 32"	8 DRAWERS R5ADD-4409 30" × 21" × 46" R5ADG-4409 30" × 27" × 46"

# COMPONENTS

## STANDARD DRAWER UNITS

To order a drawer lock with the drawer unit, add **L3** to the drawer product number.

A lock-in mechanism B is recommended for mobile applications. To order a lock-in mechanism, add **B** to the product number.



100lb. maximum load capacity for each drawer in a unit to avoid destabilizing the workstation when drawers are opened.

### 6"H AND 7"H DRAWER UNIT



1 DRAWER

LD77-3201__	18" x 21" x 6"
LD77-4201__	18" x 27" x 6"

1 DRAWER

LD77-3202__	18" x 21" x 7"
LD77-4202__	18" x 27" x 7"

NOTE: LD77 units are not stackable and not compatible with LD76 covers.

### 12"H DRAWER UNIT



2 DRAWERS

LD75-3203__	18" x 21" x 12"
LD75-4203__	18" x 27" x 12"

2 DRAWERS

LD75-3204__	18" x 21" x 12"
LD75-4204__	18" x 27" x 12"

### 9"H DRAWER UNIT



1 DRAWER

LD75-3201__	18" x 21" x 9"
LD75-4201__	18" x 27" x 9"

2 DRAWERS

LD75-3202__	18" x 21" x 9"
LD75-4202__	18" x 27" x 9"

### 15"H DRAWER UNIT



2 DRAWERS

LD75-3206__	18" x 21" x 15"
LD75-4206__	18" x 27" x 15"

1 DRAWER

LD75-3207__	18" x 21" x 15"
LD75-4207__	18" x 27" x 15"

## HEAVY-DUTY DRAWER UNITS

To order a drawer lock with the drawer unit, add **L3** to the drawer product number.

A lock-in mechanism B is recommended for mobile applications. To order a lock-in mechanism, add **B** to the product number.



200lb. maximum load capacity per unit to avoid destabilizing the workstation when drawers are opened.

### 24"W DRAWER UNIT

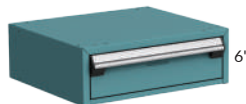

1 DRAWER

RD77-24210801__	24" x 21" x 8"
RD77-24270801__	24" x 27" x 8"

2 DRAWERS

RD77-24210802__	24" x 21" x 8"
RD77-24270802__	24" x 27" x 8"

### 30"W DRAWER UNIT

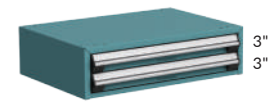

1 DRAWER

RD77-30210801__	30" x 21" x 8"
RD77-30270801__	30" x 27" x 8"

2 DRAWERS

RD77-30210802__	30" x 21" x 8"
RD77-30270802__	30" x 27" x 8"

### 36"W DRAWER UNIT



1 DRAWER

RD77-36240801__	36" x 24" x 8"
RD77-36270801__	36" x 27" x 8"

2 DRAWERS

RD77-36240802__	36" x 24" x 8"
RD77-36270802__	36" x 27" x 8"

### 48"W DRAWER UNIT

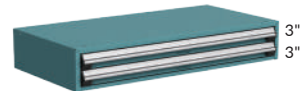

1 DRAWER

RD77-48240801__	48" x 24" x 8"
RD77-48270801__	48" x 27" x 8"

2 DRAWERS

RD77-48240802__	48" x 24" x 8"
RD77-48270802__	48" x 27" x 8"

## PAPER AND CARDBOARD SPOOL HOLDER WS86



- Installs under the work surface on WS24 leg crossbars (sold separately)
- Includes two end brackets and one rod
- Rod diameter: 1"
- Spool is inserted by pivoting one end of the rod, only one person needed
- 75lb. load capacity

PRODUCT NO.	WIDTH	COLOR
WS86-48	48"	Black
WS86-60	60"	Black
WS86-72	72"	Black

NOTE: Up to two can be installed on a WS24-21 crossbar and up to three on a WS24-27.

## POWER OUTLET STRIP EA88



- 15A power outlet strip with circuit breaker
- Mounts horizontally under a work surface or riser shelf
- Mounting hardware included

PRODUCT NO.	LENGTH	CABLE	NO. OF OUTLETS
EA88-01	12"	15'	6, with on/off switch

## PACKAGING SHEAR CUTTER WM87



- For cutting paper, corrugated cardboard, plastic, packing foam, bubble wrap, etc. For materials up to 36" wide
- Cuts in both directions

PRODUCT NO.	MATERIAL CUTTING WIDTH	OVERALL WIDTH
WM87-01	36"	48"

## UNDER THE WORK SURFACE WS ACCESSORIES



- To view all types of WS informatic/computers accessories under the work surface accessories, [see page 314](#).



# WS / EW WORKBENCH

## DISTINCTIVE FEATURES

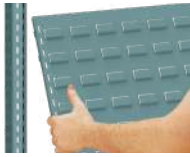

**ACCESSORIES**  
Easy and mostly tool-free reconfiguration means that your workstation can evolve in line with your needs.

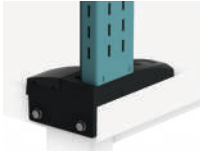

**RETROFIT**  
Our EW frames can be installed on most industrial workbenches available on the market.

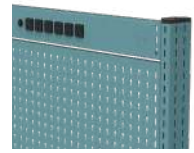

**FINISH**  
Accessories seamlessly integrate with no visible screws or gaps, offering a uniform overall appearance.  
  
The base of the EW post aligns perfectly with the edges of the work surface, ensuring an immaculate finish and a streamlined modular design.

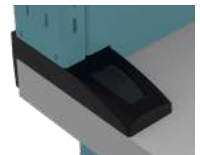

## GENERAL DIMENSIONS

WIDTH × HEIGHT ABOVE

RISER SHELVES



EW BENCH FRAMES

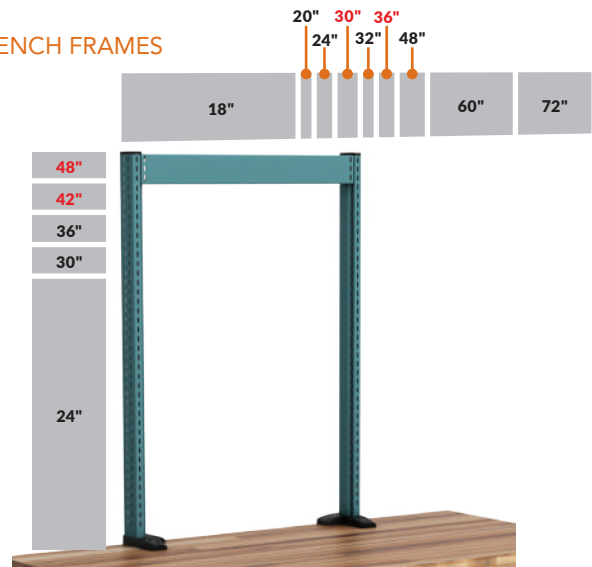

NOTE: Popular dimensions are shown in red.

## DIMENSIONAL LOGIC

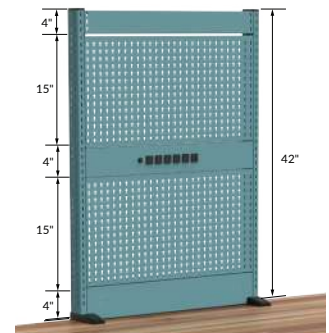
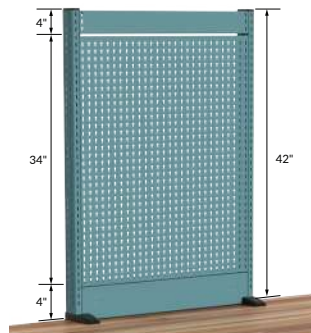
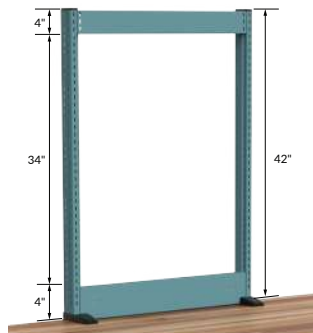

## WORKSTATIONS WITH EW BENCH FRAMES

### ELECTRONIC WORKBENCH



EC3002C

- 1 double EW bench frame
- 1 pair of cantilever overhead supports
- 1 overhead LED workstation light
- 1 storage cabinet with door
- 1 tiltable shelf
- 4 partial dividers
- 1 plastic bin panel
- 5 plastic bins
- 1 tiltable pan
- 1 LED work lamp with magnifier
- 1 laptop arm
- 1 front backplash with 6 power outlets (15A)
- 1 front backplash
- 1 dissipative top
- 1 leg, 27"D × 32"H
- 1 L Compact Cabinet with 4" base
- 1 ESD protection kit for workstations
- 1 grounding cord

DIMENSIONS			TYPE OF TOP
W	D	H	DISSIPATIVE
60"	30"	82"	EC3002C

### BASIC WORKSTATION



WEC0133

- 1 single EW bench frame
- 2 tiltable shelves
- 6 partial dividers
- 1 plastic bin panel
- 3 plastic bins
- 1 front backplash with 6 power outlets (15A)
- 1 painted steel top
- 2 legs, 27"D × 32"H
- 1 stringer

DIMENSIONS			TYPE OF TOP
W	D	H	PAINTED STEEL
60"	30"	82"	WEC0133

### PACKAGING STATION



WEM0006

- 1 single EW bench frame
- 2 steel shelves
- 6 sliding dividers
- 1 document holder
- 1 front backplash with 6 power outlets (15A)
- 1 laminated hardwood top
- 2 legs, 27"D × 32"H
- 2 leg crossbars
- 1 stringer
- 1 paper and cardboard spool holder

DIMENSIONS			TYPE OF TOP
W	D	H	LAMINATED HARDWOOD
60"	30"	82"	WEM0006



**SOLD SEPARATELY**

WM87-01 Packaging Shear Cutter

See page 153, for product details.

# PRECONFIGURED MODELS

## END-OF-AISLE WORKSTATION



WEC2001

- 1 single EW bench frame
- 1 tiltable shelf
- 3 partial dividers
- 1 utility panel
- 1 pack of 10 hooks
- 1 document holder
- 1 front backsplash with 6 power outlets (15A)
- 1 laminated hardwood top
- 1 sliding keyboard tray WS90-01 or adjustable keyboard tray WS90-02 (except on model without keyboard tray WEC2003)
- 2 closed legs, 27"D x 32"H

DIMENSIONS			KEYBOARD TRAY		
W	D	H	WS90-01 SLIDING	WS90-02 ADJUSTABLE	WITHOUT KEYBOARD TRAY
36"	30"	82"	WEC2002	WEC2001	WEC2003

## QUALITY CONTROL WORKSTATION



EC3127C

- 1 single EW bench frame
- 1 pair of cantilever overhead supports
- 1 overhead LED workstation light
- 1 utility panel
- 1 pack of 10 hooks
- 1 tiltable shelf
- 3 partial dividers
- 1 monitor and keyboard arm
- 1 front backsplash with 6 power outlets (15A)
- 1 white plastic laminate top
- 1 leg, 27"D x 32"H
- 1 L Compact Cabinet with 4" base

DIMENSIONS			TYPE OF TOP
W	D	H	PLASTIC LAM.
60"	30"	82"	EC3127C

## ASSEMBLY WORKSTATION



EC3013

- 1 double EW bench frame
- 1 pair of cantilever overhead supports
- 1 tool rail
- 1 balancer trolley
- 1 tool balancer
- 1 overhead LED workstation light
- 2 utility panels
- 2 packs of 10 hooks
- 1 document holder
- 2 plastic bin rails
- 5 plastic bins
- 1 front backsplash with 6 power outlets (15A)
- 1 front backsplash
- 1 white plastic laminate top
- 1 drawer unit
- 2 legs, 27"D x 32"H
- 1 stringer

DIMENSIONS			TYPE OF TOP
W	D	H	PLASTIC LAM.
60"	30"	82"	EC3013

## REPAIR AND MAINTENANCE WORKSTATION



EC2106L3C

- 1 double EW bench frame
- 1 storage cabinet with door
- 1 tiltable shelf
- 2 partial dividers
- 2 utility panels
- 1 pack of 10 hooks
- 1 screwdriver holder
- 1 pliers holder
- 1 plastic bin panel
- 3 plastic bins
- 1 front backsplash
- 1 front backsplash with 6 power outlets (15A)
- 1 laminated hardwood top
- 1 leg, 27"D × 32"H
- 1 L Compact Cabinet with 4" base

DIMENSIONS			TYPE OF TOP
W	D	H	LAMINATED HARDWOOD
60"	30"	82"	EC2106L3C

## LABELING WORKSTATION



EC2115L3C

- 1 double EW bench frame
- 1 pair of cantilever overhead supports
- 1 overhead LED workstation light
- 2 wire spool holders
- 1 tiltable shelf
- 2 partial dividers
- 1 utility panel
- 1 pack of 10 hooks
- 1 plastic bin panel
- 6 plastic bins
- 1 front backsplash with 6 power outlets (15A)
- 1 laminated hardwood top
- 1 leg, 27"D × 32"H
- 1 L Compact Cabinet with 4" base

DIMENSIONS			TYPE OF TOP
W	D	H	LAMINATED HARDWOOD
60"	30"	82"	EC2115L3C

## DOUBLE WORKSTATION

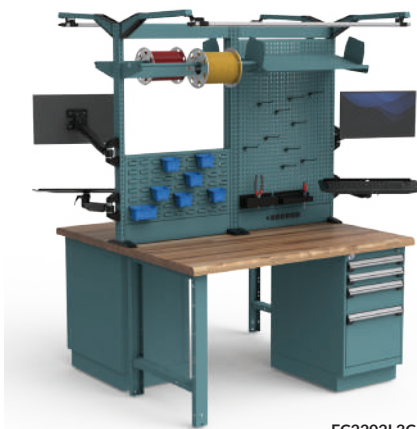

EC2202L3C

- 2 pairs of EW double sided uprights
- 2 front crossmembers
- 2 rear crossmembers
- 2 pairs of cantilever overhead supports
- 2 overhead LED workstation lights
- 2 wire spool holders
- 2 tiltable shelves
- 4 partial dividers
- 2 plastic bin panels
- 16 plastic bins
- 2 utility panels
- 2 screwdriver holders
- 2 pliers holders
- 2 monitor, keyboard and mouse arm kits
- 1 backsplash cover
- 2 front backsplashes
- 1 front backsplash with 6 power outlets (15A)
- 1 backsplash with grommet
- 2 laminated hardwood tops
- 1 pair of junction plates for work surfaces
- 2 legs, 27"D × 32"H
- 2 L Compact Cabinets with 4" base

DIMENSIONS			TYPE OF TOP
W	D	H	LAMINATED HARDWOOD
60"	60"	82"	EC2202L3C

# PRECONFIGURED MODELS

## BASIC WORKSTATION WITH R HEAVY-DUTY CABINET



R5EH5-2005

- 1 double EW bench frame
- 2 storage cabinets with double integrated doors
- 1 laminated hardwood top
- 1 leg, 27"D × 32"H
- 1 heavy-duty cabinet (subdivided drawers)

DIMENSIONS			TYPE OF TOP
W	D	H	LAMINATED HARDWOOD
60"	30"	82"	R5EH5-2005

## ASSEMBLY WORKSTATION WITH R HEAVY-DUTY CABINET



R5EH5-2003

- 1 double EW bench frame
- 1 steel shelf
- 1 plastic bin panel
- 1 privacy panel
- 7 plastic bins
- 1 tiltable shelf
- 2 partial dividers
- 1 front backsplash
- 1 front backsplash with 6 power outlets (15A)
- 1 laminated hardwood top
- 1 leg, 27"D × 32"H
- 1 heavy-duty cabinet (subdivided drawers)

DIMENSIONS			TYPE OF TOP
W	D	H	LAMINATED HARDWOOD
60"	30"	82"	R5EH5-2003

## MAINTENANCE WORKSTATION WITH R HEAVY-DUTY CABINETS



R5EL5-2003

- 1 double EW bench frame
- 1 pair of cantilever overhead supports
- 1 overhead LED workstation light
- 1 tool rail
- 1 balancer trolley
- 1 tool balancer
- 2 storage cabinets with door
- 1 plastic bin rail
- 4 plastic bins
- 1 utility panel
- 1 tiltable shelf
- 2 partial dividers
- 1 tiltable pan
- 2 tool holders
- 1 monitor and keyboard arm
- 1 document holder
- 1 front backsplash
- 1 front backsplash with 6 power outlets (15A)
- 1 laminated hardwood top
- 2 heavy-duty cabinets (subdivided drawers)
- 1 steel shelf

DIMENSIONS			TYPE OF TOP
W	D	H	LAMINATED HARDWOOD
72"	30"	82"	R5EL5-2003

## WORKBENCHES WITH RISER SHELVES

### BASIC ELECTRONIC WORKBENCH



WSA4073

- 1 top of your choice
- 2 legs, 27"D × 32"H
- 1 backstop
- 1 stringer
- 1 pair of risers with power outlets on each riser
- 1 shelf, 12"D, same material as the top
- 1 shelf backsplash

DIMENSIONS			TYPE OF TOP		
W	D	H	LAMINATED HARDWOOD	PLASTIC LAM.*	DISSIPATIVE
60"	30"	34"	WSA2073	WSA3073*	WSA4073
72"	30"	34"	WSA2074	WSA3074*	WSA4074
72"	36"	34"	WSA2075	WSA3075*	WSA4075

NOTES: \* The plastic laminate top is white by default. See page 144 for another option.  
Models with dissipative tops include an ESD protection kit for workstations. See page 181.

### ELECTRONICS WORKBENCH WITH COMPACT CABINET



LG4104C

- 1 top of your choice
- 1 leg, 27"D × 32"H
- 1 L Compact Cabinet with 4" base
- 1 backstop
- 1 pair of risers with power outlets on each riser
- 1 shelf, 12"D, same material as the top
- 1 shelf backsplash

DIMENSIONS			TYPE OF TOP		
W	D	H	LAMINATED HARDWOOD	PLASTIC LAM.*	DISSIPATIVE
60"	30"	34"	LG2104C	LG3104C*	LG4104C
72"	30"	34"	LG2105C	LG3105C*	LG4105C
72"	36"	34"	LH2106C	LH3106C*	LH4106C

NOTES: \* The plastic laminate top is white by default. See page 144 for another option.  
Models with dissipative tops include an ESD protection kit for workstations. See page 181.



# COMPONENTS

## RISER SHELVES

### PAINTED STEEL SHELF

WS50



- Thickness: 1¼"
- Compatible with all riser shelf supports
- Actual width = nominal width - 3¼"

### LAMINATED HARDWOOD SHELF

WS51



- Made from varnished hardwood slats
- Thickness: 1¼"
- Compatible with WS54, WS55 and WS59
- Attractive appearance

### PLASTIC LAMINATE SHELF

WS52



- Colors: Default is white. Add -BA for black or -GB for gray to the end of the product number
- Thickness: 1¼"
- Sides protected with ⅛"-thick durable PVC
- Compatible with WS54, WS55 and WS59
- Attractive appearance



### DISSIPATIVE SHELF

WS53



- Dissipates electrical charges that can damage electronic components
- The resistance point to point and point to ground is between 10<sup>6</sup>Ω and 10<sup>9</sup>Ω
- Color: white
- Thickness: 1¼"
- Sides protected with ⅛"-thick durable PVC
- Compatible with WS54, WS55 and WS59

### STAINLESS STEEL SHELF

WS56



- Thickness: 1¼"
- #4 brushed finish
- Compatible with all riser shelf supports
- Actual width = nominal width - 3¼"

### RESISTANT ACRYLIC / PVC LAMINATE SHELF

WS57



- Color: gray
- Thickness: 1¼"
- Sides protected with ⅛"-thick durable PVC
- Compatible with WS54, WS55 and WS59

NOTE: Grounding accessories are sold separately, [see page 181](#).

#### DIMENSIONS

#### TYPE OF SHELF

W	D	PAINTED STEEL	LAMINATED HARDWOOD	PLASTIC LAMINATE	DISSIPATIVE	STAINLESS STEEL	ACRYLIC / PVC LAMINATE
48"	12"	WS50-4812	WS51-4812	WS52-4812-__	WS53-4812	WS56-4812	WS57-4812
60"	12"	WS50-6012	WS51-6012	WS52-6012-__	WS53-6012	WS56-6012	WS57-6012
72"	12"	WS50-7212	WS51-7212	WS52-7212-__	WS53-7212	WS56-7212	WS57-7212

### RISER SHELF SUPPORTS

WS54



- Sold in pairs
- Compatible with WS50 (12"D), WS51, WS52, WS53, WS56 and WS57 shelves
- Height: 16"
- Attractive appearance

PRODUCT NO.	W × D × H
WS54-1602	3½" × 10¼" × 16"

### RISER SHELF SUPPORTS WITH POWER OUTLETS ON BOTH SIDES

WS55



- Sold in pairs
- Each support includes either three 15A outlets for 15A circuit or three 15A outlets for 15A circuit with two USB ports (1 A, 1 C)
- Compatible with WS50 (12"D), WS51, WS52, WS53, WS56 and WS57 shelves
- Dimensions: 3½"W × 10 ¼"D × 16"H
- Attractive appearance

PRODUCT NO.	OPTIONS
WS55-161002	3 power outlets (15A)
WS55-161202	3 power outlets (15A), 2 USB ports (1 A, 1 C)

## RISER SHELF SUPPORTS WITH POWER OUTLETS ON ONE SIDE

WS59



- Sold in pairs
- One support includes either three 15A outlets for 15A circuit or three 15A outlets for 15A circuit with two USB ports (1 A, 1 C)
- Compatible with WS50 (12"D), WS51, WS52, WS53, WS56 and WS57 shelves
- Dimensions: 3 1/2"W x 10 1/4"D x 16"H
- Attractive appearance

PRODUCT NO.	OPTIONS
WS59-161002	3 power outlets (15A)
WS59-161202	3 power outlets (15A), 2 USB ports (1 A, 1 C)

## ECONO RISER SHELF SUPPORTS

WS82



- Sold in pairs
- Can support one or two 12"D shelves
- Compatible with WS50 and WS56 shelves only
- Total height: 16"
- Mid-height shelf: 8"
- Easy to assemble

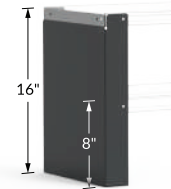

PRODUCT NO.	HEIGHT
WS82-1601	16"

## SHELF BACK OR FRONT STOP

WS58 / WS99



- Painted steel: WS58
- Stainless steel: WS99
- Compatible with WS50, WS51, WS52, WS53, WS56 and WS57 shelves
- Prevents objects from falling from riser shelves
- Extends above shelf by 1"
- To order: Specify the type of steel required: WS58 for painted steel and WS99 for stainless steel
- To order a WS99 in stainless steel, add 01 to the product number for installation at the back of the shelf and 02 for installation at the front

PRODUCT NO.	W x H	FOR SHELF
WS__-48__	45"W x 2 1/4"H	48" W
WS__-60__	57"W x 2 1/4"H	60" W
WS__-72__	69"W x 2 1/4"H	72" W

## BACK PANEL FOR RISER SHELF

WS83 / WS93



- Painted steel: WS83
- Stainless steel: WS93
- Installs behind the work surface and riser shelf
- Compatible with all types of top and shelf
- Includes holes for running cables through
- Height: 20"
- Extends above the riser shelf to prevent objects from falling
- To order: Specify the type of steel required, e.g., WS83-4616 for painted steel

PRODUCT NO.	WIDTH
WS__-4816	48"
WS__-6016	60"
WS__-7216	72"

## LED LIGHT FOR RISER SHELF

WS7A



- Brightens shaded areas under riser shelves
- Emits a brighter light than fluorescent tubes and is more energy efficient
- Color temperature: 5000-6000K (daylight white)
- Includes a 10' power cord
- Installs under the riser shelf
- Two different galvanized steel adapters available
  - Adapter 01 for WS51, WS52, WS53 and WS57 shelves
  - Adapter 02 for WS50 and WS56 shelves
- For a motion sensor (3 switch positions available), complete the product number with MS

WIDTH	REAL LIGHT WIDTH	FOR SHELF
18", 24", 30"	15", 21", 27"	36" and more
36"	33"	48" and more
48"	45"	60" and more
60"	57"	72"

NOTE: The motion detector is not available for a width of 18".

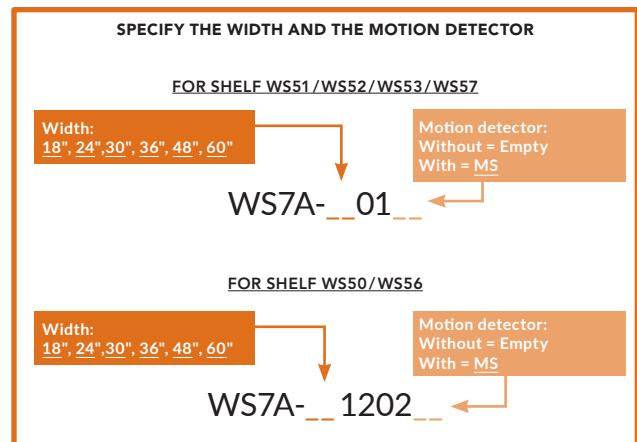

# COMPONENTS

## EW BENCH FRAMES

### EW BENCH FRAME



EW11 / EW12 / EW13

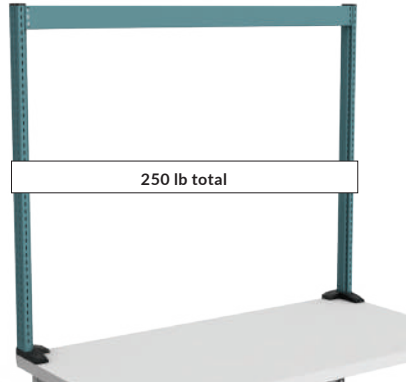

Single frame (EW11)

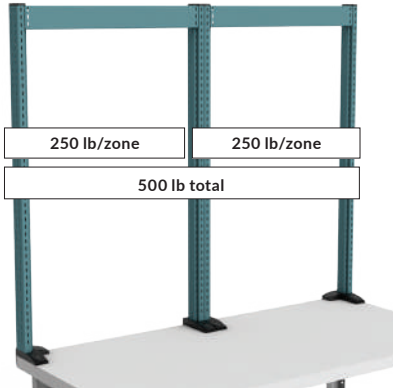

Double frame (EW12)

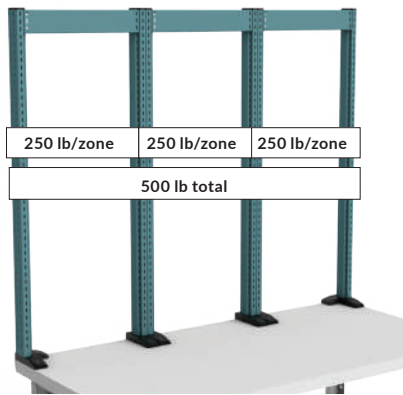

Triple frame (EW13)

- Compatible with most workbench tops available on the market. Requires a good quality top at least 1½" thick
- Includes up to five mounting zones to minimize interference between components
- Perforated on the front and back faces in 1" increments c/c for optimal placement of accessories ① ② ③ ④ ⑤
- Includes an inner mounting zone for panels, crossmembers, and backslashes at the front and rear ① ② ; a mounting zone for accessories at the front and rear ③ ④ ; and a mounting zone on the side ⑤
- Load capacity: 250lb. per zone, 500lb. total per workstation
- Available widths for double structures (EW12): 36", 48", 60" and 72"
- Available widths for triple structures (EW13): 60" and 72"
- To order: Complete the product number with number of zones:
  - EW11 for a single frame
  - EW12 for a double frame
  - EW13 for a triple frame
- Options available based on the crossmember:
  - 10: No perforations
  - 20: Pneumatic connection
  - 31: 6 power outlets (15A) for 15A circuits
  - 41: 5 power outlets (15A) for 15A circuits and 2 USB ports (1 A, 1 C)
  - 51: Perforation for installing a phone jack or network port (finishing plate included)

NOTE: See page 165 for details about the crossmember.

#### ZONE AND CROSSMEMBER OPTIONS FOR EW BENCH FRAMES

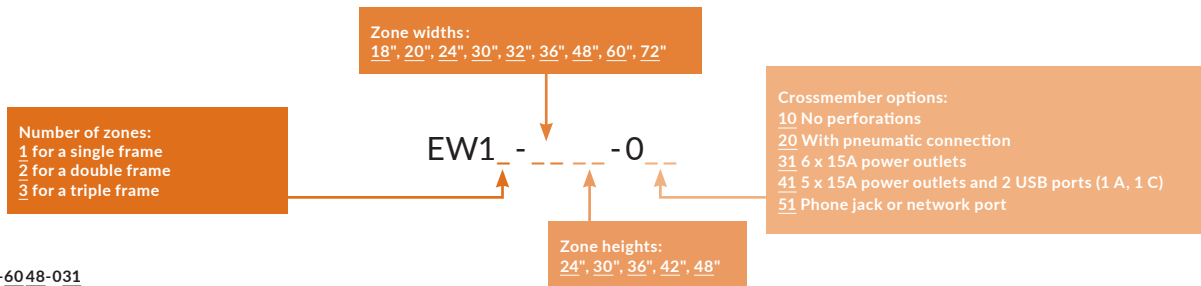

e.g., EW11-6048-031

For a single bench frame 60"W x 48"H and crossmember option with 6 x 15A power outlets.

NOTES: One zone (EW11) includes an EW10 end upright kit and an EP30 crossmember.

Two zones (EW12) includes an EW10 end upright kit, an EW20 common upright kit, and two identical EP30 crossmembers.

Three zones (EW13) includes an EW10 end upright kit, two EW20 common upright kits, and three identical EP30 crossmembers.

## END UPRIGHTS

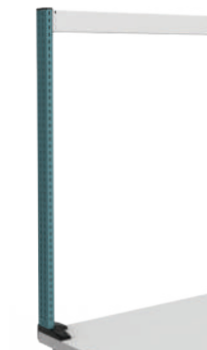

- For building an EW11 single frame
- Sold in pairs
- A pair of EW20 common uprights must be added for an EW12 double frame
- Two pairs of EW20 common uprights must be added for an EW13 triple frame
- The bases of the uprights include plastic screw covers for an immaculate finish
- Dimensions of each base: 2"W x 6"D
- The upper part of the uprights includes an endcap with a sliding button that prevents the crossmembers and cantilever arm from coming loose
- Up to five mounting zones available:
  - 1 FRONT INNER mounting zone for panels, crossmembers and backsplashes
  - 2 REAR INNER mounting zone for panels, crossmembers and backsplashes
  - 3 FRONT mounting zones for installing accessories such as shelves, cantilever arms, spool holders, etc.
  - 4 REAR mounting zones for installing accessories such as shelves, cantilever arms, spool holders, etc.
  - 5 SIDE mounting zone

PRODUCT NO.	HEIGHT
EW10-24	24"
EW10-30	30"
EW10-36	36"
EW10-42	42"
EW10-48	48"

NOTE: Not compatible with EW50 front/back backslash.

## COMMON UPRIGHT

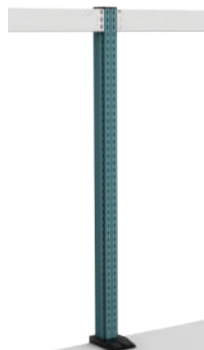

- For building an EW12 double or EW13 triple frame
- Must be combined with EW10 end uprights
- Sold in pair
- The bases of the upright include plastic screw covers for an immaculate finish
- Dimension of each base: 4"W x 6"D
- The upper part of the uprights includes an endcap with a sliding button that prevents the crossmembers and cantilever arm from coming loose
- Up to four mounting zones available:
  - 1 FRONT INNER mounting zone for panels, crossmembers and backsplashes
  - 2 REAR INNER mounting zone for panels, crossmembers and backsplashes
  - 3 FRONT mounting zones for installing accessories such as shelves, cantilever arms, spool holders, computer arms, etc.
  - 4 REAR mounting zones for installing accessories such as shelves, cantilever arms, spool holders, computer arms, etc.

PRODUCT NO.	HEIGHT
EW20-24	24"
EW20-30	30"
EW20-36	36"
EW20-42	42"
EW20-48	48"

NOTE: Not compatible with EW50 front/back backslash.

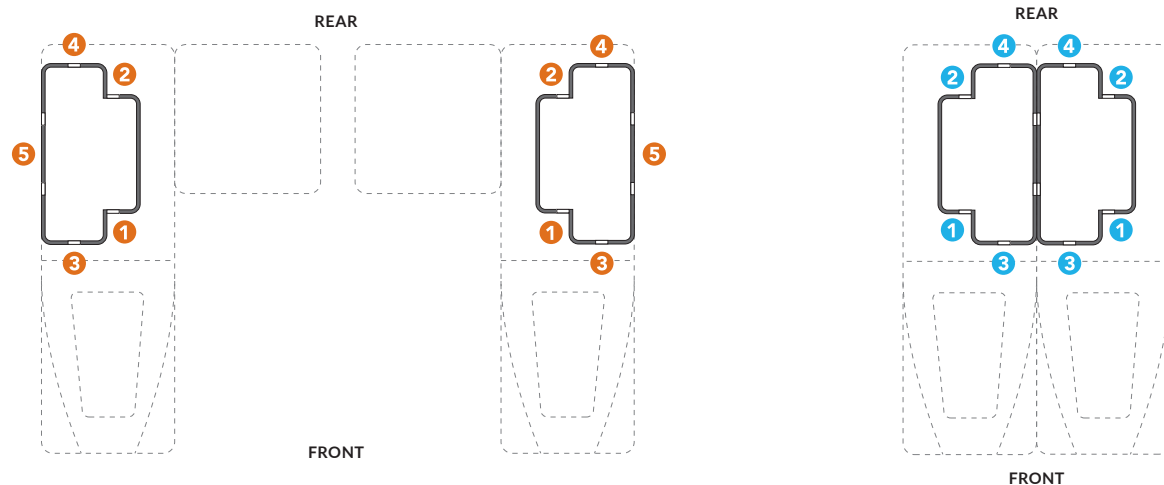

Zones 4 allow for accessories to be mounted on the rear. To prevent tipping, it's recommended to anchor the workstation to the ground. See pages 35 and 146.

# COMPONENTS

## DOUBLE-SIDED UPRIGHTS

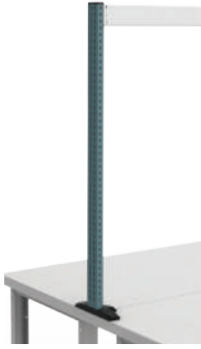

- Allow an EW structure to be positioned anywhere on a work surface
- Allow the structure to be shared between two users, one at the front and one at the rear
- Compatible with two back-to-back work surfaces
- Sold in pairs
- Uprights can be installed on the left or right or reversed to create a common upright
- Dimensions of each base:
  - End uprights: 4"W x 9¾"D
  - Common uprights: 8"W x 9¾"D
- The upper part of the uprights includes an endcap with a sliding button that prevents the crossmembers and cantilever arm from coming loose

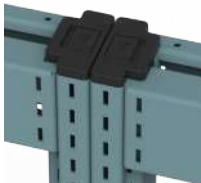

- Up to nine mounting zones available:
  - 1 FRONT INNER mounting zone for panels, crossmembers and backslashes
  - 2 REAR INNER mounting zone for panels, crossmembers and backslashes
  - 3 FRONT mounting zones for installing accessories such as shelves, cantilever arms, spool holders, etc.
  - 4 REAR mounting zones for installing accessories such as shelves, cantilever arms, spool holders, etc.
  - 5 SIDE mounting zone

- 1 FRONT INNER mounting zone for panels, crossmembers and backslashes
- 2 REAR INNER mounting zone for panels, crossmembers and backslashes
- 3 FRONT mounting zones for installing accessories such as shelves, cantilever arms, spool holders, computer arms, etc.
- 4 REAR mounting zones for installing accessories such as shelves, cantilever arms, spool holders, computer arms, etc.

PRODUCT NO.	HEIGHT
EW30-24	24"
EW30-30	30"
EW30-36	36"
EW30-42	42"
EW30-48	48"



NOTES: Not compatible in mobile version.

EW34 junction plates for work surfaces are required to connect the two surfaces and ensure installation stability.

## JUNCTION PLATES FOR WORK SURFACES



- Sold in pairs
- Enable two work surfaces to be joined WS10, WS12, WS14, WS16, WS17, WS08, RC35 or RC37
- Required when installing EW30 uprights on two separate work surfaces in a back-to-back configuration

PRODUCT NO.	W×H×D
EW34-01	3"×5/8"×6"

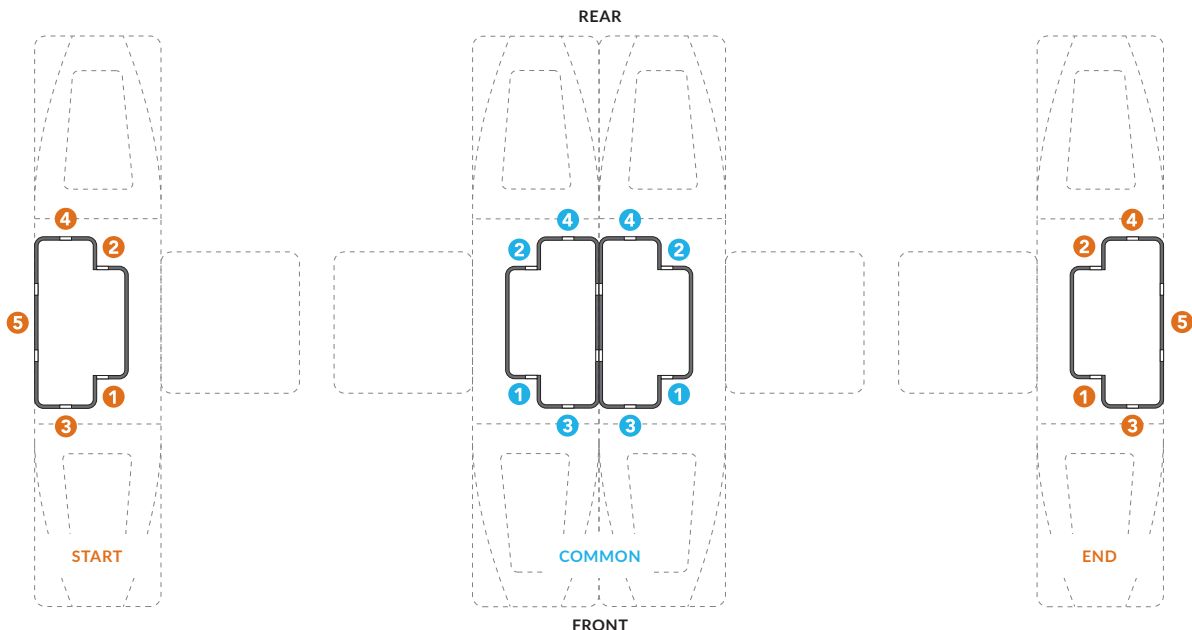

## CROSSMEMBERS

### FRONT CROSSMEMBER

EP30

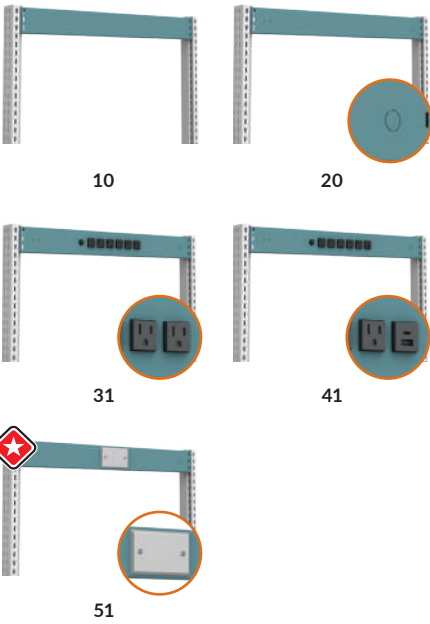

- Installs on the inner side of EW uprights ① ①
- Must be installed between two uprights to ensure rigidity of the frame
- Height: 4"
- To order: Specify the option required:
  - 10: No perforations
  - 20: Pneumatic connection
  - 31: 6 power outlets (15A) for 15A circuits
  - 41: 5 power outlets (15A) for 15A circuits and 2 USB ports (1 A, 1 C)
  - 51: Perforation for installing a phone jack or network port (finishing plate included)

PRODUCT NO.	W x H
EP30-1804-0__	18" x 4"
EP30-2004-0__	20" x 4"
EP30-2404-0__	24" x 4"
EP30-3004-0__	30" x 4"
EP30-3204-0__	32" x 4"
EP30-3604-0__	36" x 4"
EP30-4804-0__	48" x 4"
EP30-6004-0__	60" x 4"
EP30-7204-0__	72" x 4"

NOTE: Two EP30 crossmembers cannot be placed back to back.

### REAR CROSSMEMBER

EP32

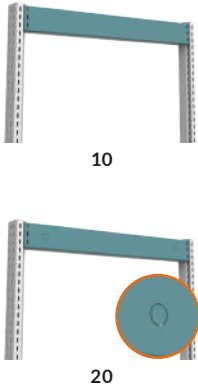

- Installs on the rear of an EP30 crossmember, between two uprights to close the back of a workstation ② ②
- The space between the EP30 crossmember and EP32 rear crossmember can be used for cable management
- Height: 4"
- To order: Specify the option required:
  - 10: No perforations
  - 20: Pneumatic connection

PRODUCT NO.	W x H
EP32-1804-0__	18" x 4"
EP32-2004-0__	20" x 4"
EP32-2404-0__	24" x 4"
EP32-3004-0__	30" x 4"
EP32-3204-0__	32" x 4"
EP32-3604-0__	36" x 4"
EP32-4804-0__	48" x 4"
EP32-6004-0__	60" x 4"
EP32-7204-0__	72" x 4"

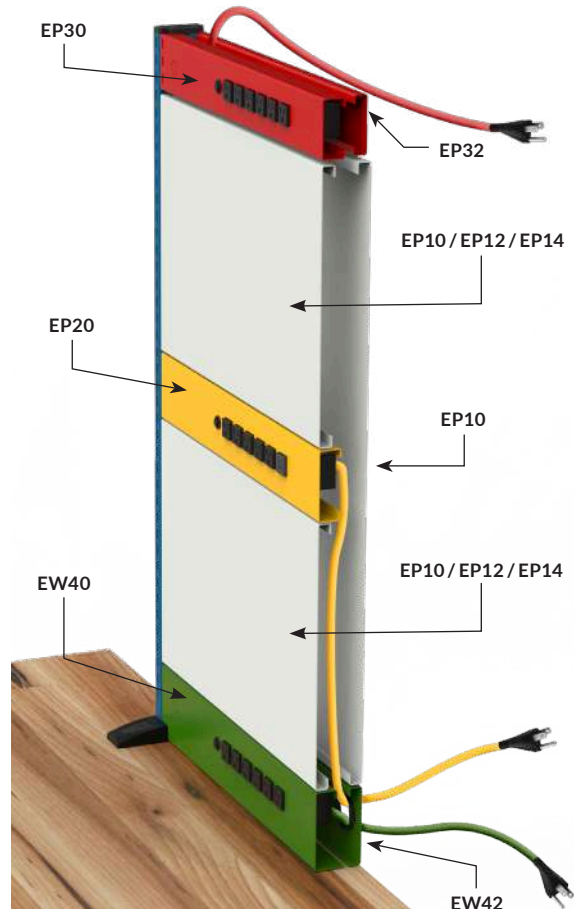

NOTES: The color scheme is used for demonstration purposes only.  
For a configuration as illustrated, with the back fully closed, a rear backslash EW42-WW04-080 is required to allow wire routing at the back of the structure.

# ACCESSORIES

## BACKSPLASHES

### FRONT BACKSPLASH

EW40

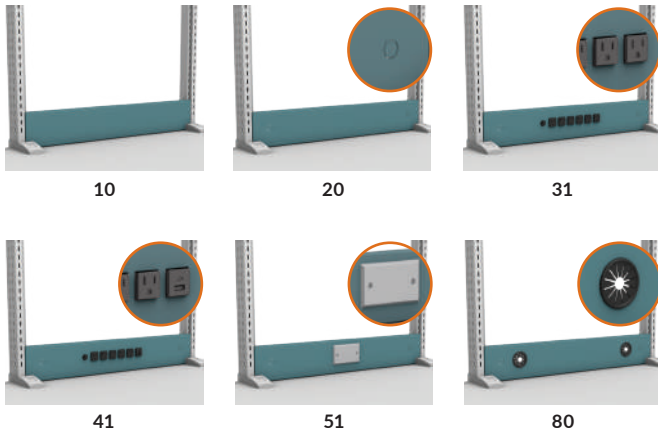

- Installs on the inner side of EW uprights ① ① (except EW30)
- Closes the bottom of an EW frame
- Height: 4"
- To order: Specify the option required:
  - 10: No perforations
  - 20: Pneumatic connection
  - 31: 6 power outlets (15A) for 15A circuits
  - 41: 5 power outlets (15A) for 15A circuits and 2 USB ports (1 A, 1 C)
  - 51: Perforation for installing a phone jack or network port (finishing plate included)
  - 80: Grommet

PRODUCT NO.	W × H
EW40-1804-0__	18" × 4"
EW40-2004-0__	20" × 4"
EW40-2404-0__	24" × 4"
EW40-3004-0__	30" × 4"
EW40-3204-0__	32" × 4"
EW40-3604-0__	36" × 4"
EW40-4804-0__	48" × 4"
EW40-6004-0__	60" × 4"
EW40-7204-0__	72" × 4"

NOTES: Two EW40 backsplashes cannot be placed back to back.  
For compatibility with EW30 uprights, see front/rear backsplash for EW30 (EW50). [See page 167.](#)

### REAR BACKSPLASH

EW42

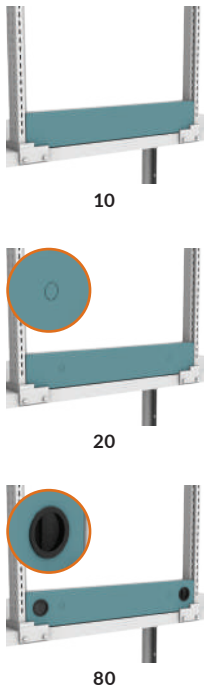

- Installs on the rear of an EW40 backsplash between two uprights to close the back of the workstation ② ② (except EW30)
- Attractive appearance
- Height: 4"
- To order: Specify the option required:
  - 10: No perforations
  - 20: Pneumatic connection
  - 80: Grommet

PRODUCT NO.	W × H
EW42-1804-0__	18" × 4"
EW42-2004-0__	20" × 4"
EW42-2404-0__	24" × 4"
EW42-3004-0__	30" × 4"
EW42-3204-0__	32" × 4"
EW42-3604-0__	36" × 4"
EW42-4804-0__	48" × 4"
EW42-6004-0__	60" × 4"
EW42-7204-0__	72" × 4"

NOTE: For compatibility with EW30 uprights, see front/rear backsplash for EW30 (EW50). [See page 167.](#)

### BACKSPLASH COVER

EA71



- Fills the opening between the backsplash, originally intended for cable management, between two front and rear backsplashes EW40, EW42 and EW50
- Improves the aesthetics of the workstation
- Removable as needed

PRODUCT NO.	WIDTH
EA71-18	18"
EA71-20	20"
EA71-24	24"
EA71-30	30"
EA71-32	32"
EA71-36	36"
EA71-48	48"
EA71-60	60"
EA71-72	72"



## FRONT/BACK BACKSPLASH FOR EW30

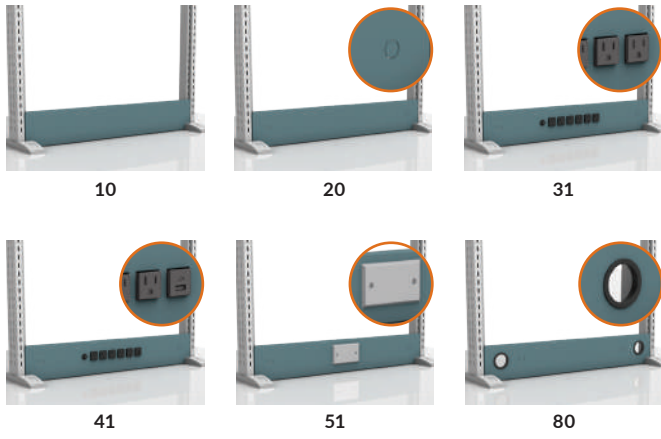

- Installs on the inner side of EW30 uprights ① ① ② ②
- Closes the bottom of an EW frame
- Height: 4"
- To order: Specify the option required:
  - 10: No perforations
  - 20: Pneumatic connection
  - 31: 6 power outlets (15A) for 15A circuits
  - 41: 5 power outlets (15A) for 15A circuits and 2 USB ports (1 A, 1 C)
  - 51: Perforation for installing a phone jack or network port (finishing plate included)
  - 80: Grommet

PRODUCT NO.	W x H
EW50-1804-0__	18" x 4"
EW50-2004-0__	20" x 4"
EW50-2404-0__	24" x 4"
EW50-3004-0__	30" x 4"
EW50-3204-0__	32" x 4"
EW50-3604-0__	36" x 4"
EW50-4804-0__	48" x 4"
EW50-6004-0__	60" x 4"
EW50-7204-0__	72" x 4"

NOTES: Two backsplashes cannot be placed back to back with options 31, 41 or 51. To completely close the backsplash with options 31, 41 or 51, you can use options 10, 20 or 80. e.g., An EW50 front backsplash with option 31 and an EW50 rear backsplash with option 80.  
Refer to the E34 assembly guide for wire management.

## ELECTRICAL APPLICATIONS

### POWER OUTLET CHANNEL

EP20

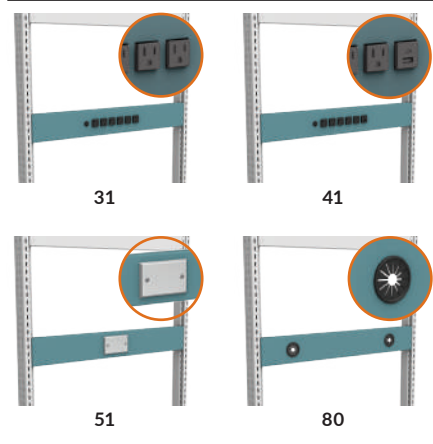

- Installs at any height between EW uprights (excluding the space needed for the crossmember and backsplash) ① ① ② ②
- Height: 4"
- To order: Specify the option required:
  - 31: 6 power outlets (15A) for 15A circuits
  - 41: 5 power outlets (15A) for 15A circuits and 2 USB ports (1 A, 1 C)
  - 51: Perforation for installing a phone jack or network port (finishing plate included)
  - 80: Grommet

PRODUCT NO.	W x H
EP20-1804-0__	18" x 4"
EP20-2004-0__	20" x 4"
EP20-2404-0__	24" x 4"
EP20-3004-0__	30" x 4"
EP20-3204-0__	32" x 4"
EP20-3604-0__	36" x 4"
EP20-4804-0__	48" x 4"
EP20-6004-0__	60" x 4"
EP20-7204-0__	72" x 4"

NOTE: Two power outlet channel cannot be placed back to back with options 31, 41 or 51. To completely close the power outlet channel with options 31, 41 or 51, you can use option 80. e.g., A power outlet channel with option 31 and an power outlet channel with option 80.



## PANELS

### PRIVACY PANEL

EP10

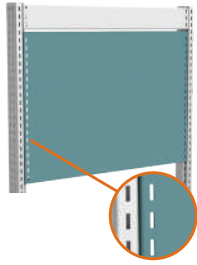

- Painted steel
- Installs on the inner side of EW uprights **1 1 2 2**
- Closes off the back of a workstation or can be used as a magnetic bulletin board
- Equipped with a row of rectangular perforations positioned at the left and right ends, which combined with the rectangular perforations of the upright create a front-mounted hanging area

- Compatible with heavy-duty articulating arms EA60, [see pages 308-309](#), and height-adjustable articulating arms EA61, [see pages 310-311](#)
- Compatible with the LED work light with magnifier EA58, the document holder EA56, and the power outlet bar EA89, [see page 174](#)
- To order: Complete the product number with the height required: 04", 08", 10", 12", 14", 15", 16", 17", 20", 24", 28", 30", 34" or 40"

PRODUCT NO.	WIDTH
EP10-18__	18"
EP10-20__	20"
EP10-24__	24"
EP10-30__	30"
EP10-32__	32"
EP10-36__	36"

### PLASTIC BIN PANEL

**5S** EP14

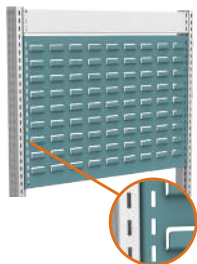

- Painted steel
- Installs on the inner side of EW uprights **1 1 2 2**
- Holds RG20 plastic bins, [see page 297](#)
- Load capacity: 50lb. per square foot or 250lb. maximum per panel
- Compatible with most brands of plastic bins (with hanging lip) on the market
- Equipped with a row of rectangular perforations positioned at the left and right ends, which combined with the rectangular perforations of the upright create a front-mounted hanging area

- Compatible with heavy-duty articulating arms EA60, [see pages 308-309](#), and height-adjustable articulating arms EA61, [see pages 310-311](#)
- Compatible with the LED work light with magnifier EA58, the document holder EA56, and the power outlet bar EA89, [see page 174](#)
- To order: Complete the product number with the height required: 08", 10", 12", 14", 15", 16", 17", 20", 24", 28", 30", 34" or 40"

PRODUCT NO.	WIDTH
EP14-18__	18"
EP14-20__	20"
EP14-24__	24"
EP14-30__	30"
EP14-32__	32"
EP14-36__	36"

### UTILITY PANEL

**5S** EP12

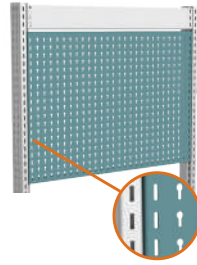

- Painted steel
- Installs on the inner side of EW uprights **1 1 2 2**
- Includes perforations spaced 1" apart c/c for hanging a range of hooks
- Load capacity: 50lb. per square foot or 250lb. maximum per panel
- Compatible with: WM9F, WM9G, WM9H, WM9J and WM9L light-duty hooks; WM9A and WM9B heavy-duty hooks, [see page 262](#)
- Compatible with: WM9C rails; WM9D, WM9M, WM9N, WM9Q, WM9P, WM9R and WM9S holders; EA50 mounts; EA52 holders; EA28 and WM21 shelves, [see pages 262-263](#)

- Equipped with a row of rectangular perforations positioned at the left and right ends, which combined with the rectangular perforations of the upright create a front-mounted hanging area
  - Compatible with heavy-duty articulating arms EA60, [see pages 308-309](#), and height-adjustable articulating arms EA61, [see pages 310-311](#)
  - Compatible with the LED work light with magnifier EA58, the document holder EA56, and the power outlet bar EA89, [see page 174](#)
- To order: Complete the product number with the height required: 04", 08", 10", 12", 14", 15", 16", 17", 20", 24", 28", 30", 34" or 40"

PRODUCT NO.	WIDTH	NO. OF HOLES
EP12-18__	18"	14
EP12-20__	20"	16
EP12-24__	24"	20
EP12-30__	30"	26
EP12-32__	32"	28
EP12-36__	36"	32



NOTE: The color scheme is used for demonstration purposes only.

NOTES: The panel width must be the same width as the zone, e.g., a 30"W panel must be installed on a 30"W zone.  
Actual Width: Nominal - 2 3/16". Actual Height: Nominal - 5/16".

## SHELVES

### TILTABLE SHELF EA20

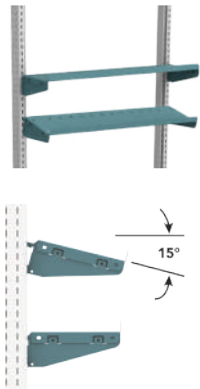

- Hooks onto the front (or rear) of EW uprights ③ ③ ④ ④
- Includes slots spaced 2" apart c/c for installing SH52 dividers, [see page 173](#)
- Includes two side brackets which can be placed at right angles or at a 15° angle
- Shelf is reversible and the edge can be used as a backsplash or support for plastic bins or for ring binders with a 12" deep shelf
- Capacity: 100lb. (evenly distributed)

PRODUCT NO.	W × D
EA20-1806	18" × 6"
EA20-1808	18" × 8"
EA20-1812	18" × 12"
EA20-2006	20" × 6"
EA20-2008	20" × 8"
EA20-2012	20" × 12"
EA20-2406	24" × 6"
EA20-2408	24" × 8"
EA20-2412	24" × 12"
EA20-3006	30" × 6"
EA20-3008	30" × 8"
EA20-3012	30" × 12"
EA20-3206	32" × 6"
EA20-3208	32" × 8"
EA20-3212	32" × 12"
EA20-3606	36" × 6"
EA20-3608	36" × 8"
EA20-3612	36" × 12"



Zones ④ ④ allow for accessories to be mounted on the rear. To prevent tipping, it's recommended to anchor the workstation to the ground. [See pages 35 and 146.](#)

### LED LIGHT FOR SHELF WS7A



- Brightens shaded areas under shelves
- Emits a brighter light than fluorescent tubes and is more energy efficient
- Color temperature: 5000-6000K (daylight white)
- Includes a 10' power cord
- Installs under the shelf
- Two different galvanized steel adapters available
  - Adapter 01 for EA08, EA14, EA16 and EA17 shelves
  - Adapter 02 for EA10, EA11 and EA12 shelves
- For a motion sensor (3 switch positions available), complete the product number with MS

WIDTH	REAL LIGHT WIDTH	FOR SHELF
18", 24", 30"	15", 21", 27"	36" and more
36"	33"	48" and more
48"	45"	60" and more
60"	57"	72"

### TILTABLE PAN EA22



- Hooks onto the inner side of EW uprights ① ① ② ②
- Three positions available: front, center or back
- Tilts from 0 to 30° with five easily adjustable positions
- Includes a full-size rubber mat
- Capacity: 200lb.

PRODUCT NO.	W × D	USABLE SURFACE AREA
EA22-1820	18" × 20"	13" × 18½"
EA22-2020	20" × 20"	15" × 18½"
EA22-2420	24" × 20"	19" × 18½"
EA22-3020	30" × 20"	25" × 18½"
EA22-3220	32" × 20"	27" × 18½"
EA22-3620	36" × 20"	31" × 18½"

### SHELF BACKSTOP EA07 / EA09



- EA07: Painted steel
- EA09: Stainless steel
- Attaches to EA08, EA10, EA11, EA12, EA14, EA16 and EA17 shelves
- Prevents objects from falling from shelves
- Extends above shelf by 1"
- Attaches to the front or back of the shelf

PRODUCT NO.	WIDTH
EA__-18	18"
EA__-20	20"
EA__-24	24"
EA__-30	30"
EA__-32	32"
EA__-36	36"
EA__-48	48"
EA__-60	60"
EA__-72	72"

NOTE: Not compatible with EA15 mesh shelves.

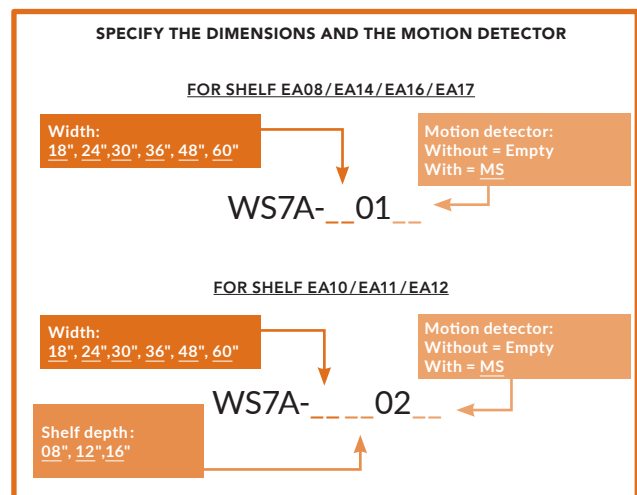

NOTES: The motion detector is not available for a width of 18".  
Not compatible with EA15 mesh shelves.

# ACCESSORIES

## RESISTANT ACRYLIC/PVC LAMINATE SHELF

EA08



- Hooks onto the front (or rear) of EW uprights 3 3 4 4
- Includes two side brackets which can be placed at right angles or at a 15° angle
- Sides protected with 1/8" thick durable PVC
- Compatible with EA07 / EA09 shelf backstop
- Thickness: 1 5/16"
- Color: gray

W	D	LOAD CAPACITY*
48" and under	8" / 12" / 16"	200 lb.
	8"	140 lb.
	12"	200 lb.
60"	16"	200 lb.
	8"	80 lb.
	12"	120 lb.
72"	16"	160 lb.

NOTE: \* Weight evenly distributed

## STAINLESS STEEL SHELF

EA12



- Hooks onto the front (or rear) of EW uprights 3 3 4 4
- Includes two side brackets which can be placed at right angles or at a 15° angle
- Compatible with EA07 / EA09 shelf backstop
- Thickness: 1 5/16"
- Capacity: 200lb. (evenly distributed)

## MESH SHELF



EA15



- Hooks onto the front (or rear) of EW uprights 3 3 4 4
- Includes two side brackets which can be placed at right angles or at a 15° angle
- Ideal for allowing light to pass through or preventing dust buildup
- Thickness: 1 1/2"
- Color: chrome-plated steel
- Capacity: 150lb. (evenly distributed)

## PAINTED STEEL SHELF

EA10 / EA11



- EA10: Solid version
- EA11: Perforated version
- Hooks onto the front (or rear) of EW uprights 3 3 4 4
- Includes two side brackets which can be placed at right angles or at a 15° angle
- Perforated version includes slots spaced 2" apart c/c for installing SH52 dividers, see page 173
- Compatible with EA07 / EA09 shelf backstop
- Thickness: 1 5/16"
- Capacity: 200lb. (evenly distributed)
- To order: Specify the type of shelf required



## LAMINATED WOOD SHELF

EA14



- Hooks onto the front (or rear) of EW uprights 3 3 4 4
- Includes two side brackets which can be placed at right angles or at a 15° angle
- Compatible with EA07 / EA09 shelf backstop
- Thickness: 1 5/16"
- Made from varnished hardwood slats
- Attractive appearance
- Capacity: 200lb. (evenly distributed)

## PLASTIC LAMINATE SHELF

EA16



- Hooks onto the front (or rear) of EW uprights 3 3 4 4
- Includes two side brackets which can be placed at right angles or at a 15° angle
- Sides protected with 1/8" thick durable PVC
- Compatible with EA07 / EA09 shelf backstop
- Thickness: 1 5/16"
- Attractive appearance
- To order: Add the color code to the product number, e.g., EA16-1808-BA for a black shelf



W	D	LOAD CAPACITY*
48" and under	8" / 12" / 16"	200 lb.
	8"	140 lb.
	12"	200 lb.
60"	16"	200 lb.
	8"	80 lb.
	12"	120 lb.
72"	16"	160 lb.

NOTE: \* Weight evenly distributed

## DISSIPATIVE SHELF

EA17



- Hooks onto the front (or rear) of EW uprights 3 3 4 4
- Includes two side brackets which can be placed at right angles or at a 15° angle
- Sides protected with 1/8" thick durable PVC
- Compatible with EA07/ EA09 shelf backstop
- Thickness: 1 5/16"
- Dissipates electrical charges that can damage electronic components
- The resistance point to point and point to ground is between 10<sup>6</sup>Ω and 10<sup>9</sup>Ω
- Complies with the ESD-S4.1-1997 standard
- Color: white

W	D	LOAD CAPACITY*
48" and under	8" / 12" / 16"	200 lb.
60"	8"	140 lb.
	12"	200 lb.
	16"	200 lb.
72"	8"	80 lb.
	12"	120 lb.
	16"	160 lb.

NOTES: \* Weight evenly distributed  
Grounding accessories are sold separately, see page 181.



EC2113C

DIMENSIONS		TYPE OF SHELF						
W	D	ACRYLIC/PVC LAMINATE	PAINTED STEEL	STAINLESS STEEL	LAMINATED HARDWOOD	MESH	PLASTIC LAM.	DISSIPATIVE
18"	8"	EA08-1808-GI	EA1_-1808	EA12-1808	EA14-1808	-	EA16-1808-__	EA17-1808-WB
	12"	EA08-1812-GI	EA1_-1812	EA12-1812	EA14-1812	-	EA16-1812-__	EA17-1812-WB
	16"	EA08-1816-GI	EA1_-1816	EA12-1816	EA14-1816	-	EA16-1816-__	EA17-1816-WB
20"	8"	EA08-2008-GI	EA1_-2008	EA12-2008	EA14-2008	-	EA16-2008-__	EA17-2008-WB
	12"	EA08-2012-GI	EA1_-2012	EA12-2012	EA14-2012	-	EA16-2012-__	EA17-2012-WB
	16"	EA08-2016-GI	EA1_-2016	EA12-2016	EA14-2016	-	EA16-2016-__	EA17-2016-WB
24"	8"	EA08-2408-GI	EA1_-2408	EA12-2408	EA14-2408	-	EA16-2408-__	EA17-2408-WB
	12"	EA08-2412-GI	EA1_-2412	EA12-2412	EA14-2412	-	EA16-2412-__	EA17-2412-WB
	14"	-	-	-	-	EA15-2414	-	-
30"	16"	EA08-2416-GI	EA1_-2416	EA12-2416	EA14-2416	-	EA16-2416-__	EA17-2416-WB
	8"	EA08-3008-GI	EA1_-3008	EA12-3008	EA14-3008	-	EA16-3008-__	EA17-3008-WB
	12"	EA08-3012-GI	EA1_-3012	EA12-3012	EA14-3012	-	EA16-3012-__	EA17-3012-WB
32"	14"	-	-	-	-	EA15-3014	-	-
	16"	EA08-3016-GI	EA1_-3016	EA12-3016	EA14-3016	-	EA16-3016-__	EA17-3016-WB
	8"	EA08-3208-GI	EA1_-3208	EA12-3208	EA14-3208	-	EA16-3208-__	EA17-3208-WB
36"	12"	EA08-3212-GI	EA1_-3212	EA12-3212	EA14-3212	-	EA16-3212-__	EA17-3212-WB
	16"	EA08-3216-GI	EA1_-3216	EA12-3216	EA14-3216	-	EA16-3216-__	EA17-3216-WB
	8"	EA08-3608-GI	EA1_-3608	EA12-3608	EA14-3608	-	EA16-3608-__	EA17-3608-WB
48"	12"	EA08-3612-GI	EA1_-3612	EA12-3612	EA14-3612	-	EA16-3612-__	EA17-3612-WB
	14"	-	-	-	-	EA15-3614	-	-
	16"	EA08-3616-GI	EA1_-3616	EA12-3616	EA14-3616	-	EA16-3616-__	EA17-3616-WB
60"	8"	EA08-4808-GI	EA1_-4808	EA12-4808	EA14-4808	-	EA16-4808-__	EA17-4808-WB
	12"	EA08-4812-GI	EA1_-4812	EA12-4812	EA14-4812	-	EA16-4812-__	EA17-4812-WB
	14"	-	-	-	-	EA15-4814	-	-
72"	16"	EA08-4816-GI	EA1_-4816	EA12-4816	EA14-4816	-	EA16-4816-__	EA17-4816-WB
	8"	EA08-6008-GI	EA1_-6008	EA12-6008	EA14-6008	-	EA16-6008-__	EA17-6008-WB
	12"	EA08-6012-GI	EA1_-6012	EA12-6012	EA14-6012	-	EA16-6012-__	EA17-6012-WB
72"	14"	-	-	-	-	EA15-6014	-	-
	16"	EA08-6016-GI	EA1_-6016	EA12-6016	EA14-6016	-	EA16-6016-__	EA17-6016-WB
	8"	EA08-7208-GI	EA1_-7208	EA12-7208	EA14-7208	-	EA16-7208-__	EA17-7208-WB
72"	12"	EA08-7212-GI	EA1_-7212	EA12-7212	EA14-7212	-	EA16-7212-__	EA17-7212-WB
	14"	-	-	-	-	EA15-7214	-	-
	16"	EA08-7216-GI	EA1_-7216	EA12-7216	EA14-7216	-	EA16-7216-__	EA17-7216-WB



Zones 4 4 allow for accessories to be mounted on the rear. To prevent tipping, it's recommended to anchor the workstation to the ground. See pages 35 and 146.

NOTE: The shelves are installed on two uprights and can be placed above a common upright.

# ACCESSORIES

## OTHER ACCESSORIES

### OVERHEAD SUPPORTS



EA40

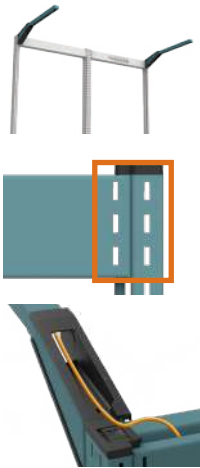

- Sold in pairs
- Supports an EA43 light and EA47 tool rail
- Hooks onto the front of EW uprights **3** **3** and on the top crossmember. The crossmember is required for installation
- Locks into place via the lockable endcap on EW uprights
- Load capacity: 60lb. per pair
- Adds 3" to the height of the frame
- Includes channels for cable management
- Includes a foam cable cover

PRODUCT NO.	DEPTH
EA40-26-02	26"

### OVERHEAD LED WORKSTATION LIGHT

EA43



- Installs on EA40 overhead supports (sold separately)
- Includes mounting brackets. The light rotates 300° in the brackets to set the direction of the light
- Installs on frames with two or three uprights
- Emits a bright light while being energy efficient
- Color temperature: 5000-6000K (daylight white)
- Color rendering index (CRI): 90+
- Includes a 10' power cord
- Each light is independent and controlled by its own switch
- Optional 12" LED connecting cable available (EQ10-12)
- Up to 7 lights can be connected in series
- For a motion sensor (3 switch positions available), complete the product number with MS, e.g., EA43-36MS for a 36"W overhead LED workstation light with motion sensor.

PRODUCT NO.	REAL LIGHT WIDTH	COMPATIBLE ZONE WIDTH
EA43-18_	15"	18 and 20
EA43-24_	21"	18, 20 and 24
EA43-30_	27"	18, 20, 24, 30 and 32
EA43-36_	33"	18, 20, 24, 30, 32 and 36
EA43-48_	45"	18, 20, 24, 30, 32, 36 and 48
EA43-60_	57"	18, 20, 24, 30, 32, 36, 48 and 60
EA43-72_	57"	72

NOTES: The motion sensor is not available for a width of 18".  
Refer to the E56 technical sheet for compatibility, dimensions and positioning.

### TOOL RAIL

EA47



- Holds one or more WM48 balancer trolleys
- Installs on EA40 cantilever overhead supports (sold separately)
- Easily adjustable depth
- Color: black
- Capacity: 25lb.

PRODUCT NO.	WIDTH
EA47-30	30"
EA47-32	32"
EA47-36	36"
EA47-48	48"
EA47-60	60"
EA47-72	72"

### JOINER FOR TOOL RAIL

WM89



- Connects two EA47 tool rails on two adjacent workstations

PRODUCT NO.
WM89-01



### BALANCER TROLLEY

WM48



- Inserts into EA47 tool rail
- Color: black
- Holds a pneumatic connection

PRODUCT NO.
WM48-01

### TOOL BALANCER

WM49



- For hanging tools over the work surface
- 6' metal cable with tension adjustment
- Color: black
- Capacity: 3lb. max.

PRODUCT NO.
WM49-01



## ADJUSTABLE DIVIDER

EA06



- Attaches to EA08, EA10, EA11, EA12, EA14, EA16 and EA17 shelves
- Slides into the desired position
- Not compatible with EA07 / EA09 shelf backstop

PRODUCT NO.	D×H	FOR SHELF
EA06-0806	8"×6"	8"D
EA06-0810	8"×10"	8"D
EA06-1206	12"×6"	12"D
EA06-1210	12"×10"	12"D
EA06-1606	16"×6"	16"D
EA06-1610	16"×10"	16"D

NOTE: Not compatible with EA15 mesh shelves.

## PARTIAL DIVIDER

SH52



- Compatible with EA20 and EA11 shelves
- Adjustable in 2" increments c/c
- Inserts into the shelf slots forwards or backwards

PRODUCT NO.	D×H	FOR SHELF
SH52-1206	7½"×5½"	8"D and 12"D
SH52-1806	13½"×5½"	16"D

## PLASTIC BIN HOLDER

EA32

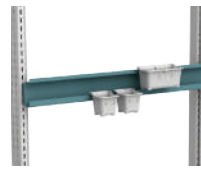

- Hooks onto the front (or rear) of EW uprights ③ ③ ④ ④
- Adjustable in 1" increments c/c
- Can be installed at a right angle or angled 15°
- Compatible with most brands of plastic bins (with hanging lip) on the market
- Compatible with all RG20 plastic bin sizes, [see page 297](#)
- Capacity: 75lb. (evenly distributed)

PRODUCT NO.	WIDTH
EA32-18	18"
EA32-20	20"
EA32-24	24"
EA32-30	30"
EA32-32	32"
EA32-36	36"
EA32-48	48"
EA32-60	60"
EA32-72	72"

NOTE: The plastic bin holder 36"W and over cannot pass over a common upright.



Zones ④ ④ allow for accessories to be mounted on the rear. To prevent tipping, it's recommended to anchor the workstation to the ground. [See pages 35 and 146.](#)

## DISPLAY AND WRITING PANEL



EA01



- Reversible dual-function panel:
  - Cork surface for note display
  - White dry-erase writing board for use with erasable markers
- The panel support is equipped with hooks for installation
- 24"W zone: Installs on EW uprights ③ ③ ④ ④
- 30", 32", and 36"W zones: Installs on an EP12 utility panel, [see page 168](#)
- The writing board is magnetic

PRODUCT NO.	W×H
EA01-2424	24"×24"

NOTE: If installed on EP12, the EP12 hanging panel must be at least 26" high.

## MAGNETIC WHITEBOARD



EA02

15"×18"



- White writing flexible board for use with erasable markers
- Magnetic backing allows attachment to any steel surface

PRODUCT NO.	W×H
EA02-1518	15"×18"
EA02-2718	18"×27"

18"×27"





Zones **4** **4** allow for accessories to be mounted on the rear. To prevent tipping, it's recommended to anchor the workstation to the ground. See pages 35 and 146.

## POWER OUTLET STRIP

EA89



- Hooks onto the side **5**, front (or rear) of EW uprights **3** **4**
- 15A power outlet strip with circuit breaker

PRODUCT NO.	LENGTH.	CABLE	NO. OF OUTLETS
EA89-01	12"	15'	6, with on/off switch

## DOCUMENT HOLDER



EA56



- Hooks onto the side **5**, front (or rear) of EW uprights **3** **4**
- The document holder (14" × 13½") includes a document clip and an edge to support binders
- Color: black
- Capacity: 20lb.

PRODUCT NO.	ARM
EA56-01	6"
EA56-02	12"

## LED WORK LAMP WITH MAGNIFIER



EA58



- Version 01 and 02 hooks onto the side **5**, front (or rear) of EW uprights **3** **4**
- Version 03 Installs directly on the work surface
- Diopter: 5 (2.25x magnification)
- Color: black

PRODUCT NO.	INSTALLATION
EA58-01	Includes a bracket for EW uprights
EA58-02	Includes a bracket for EW uprights and an arm to extend the reach by 12"
EA58-03	Installs directly on the work surface



## TV MOUNT



EA51



- Hooks onto the front (or rear) of EW uprights **3** **3** **4** **4**
- Allows a TV to be installed
- The TV can be moved horizontally on the mount
- Compatible with TVs with VESA 200 × 200, 300 × 300, 400 × 300 and 400 × 400 hole patterns
- To order: Specify the width required: e.g., EA51-36 for a television mount installed on a 36"W zone
- Color: black
- Capacity: 50lb.

PRODUCT NO.	ZONE WIDTH
EA51-18	18"
EA51-20	20"
EA51-24	24"
EA51-30	30"
EA51-32	32"
EA51-36	36"
EA51-48	48"
EA51-60	60"
EA51-72	72"

## COMPACT COMPUTER HOLDER



EA52



- Hooks onto the side **5**, front (or rear) of EW uprights **3** **4**
- Compatible with EP12 utility panel, see page 263
- For installation of compact computers (Thin Clients)
- Allows a front-mounted monitor installation
- Compatible with most monitors on the market
- Complies with VESA 50, 75 and 100 monitor mounting standards
- Computer dimensions: 1¾"W to 2"W
- Color: black
- Capacity: 10lb.

PRODUCT NO.
EA52-01

NOTES: Widths of 36" and greater are not compatible with EP14 plastic bin panels. They are installed on two uprights and can pass over a common upright.  
18" width is not compatible with VESA 400 TVs.



Zones **3** **4** allow for accessories to be mounted on the rear. To prevent tipping, it's recommended to anchor the workstation to the ground. See pages 35 and 146.

## WIRE SPOOL HOLDER

EA31



01



02

- **01**: Single version
- **02**: Double version
- Hooks onto the front (or rear) of EW uprights **3** **3** **4** **4**
- Includes two side brackets and one or two tubes
- Tube diameter: ¾"
- Maximum spool diameter:  
01 = 14½" 02 = 4½"
- Capacity: 50lb.
- To order: Specify the tube number required

PRODUCT NO.	WIDTH
EA31-18__	18"
EA31-20__	20"
EA31-24__	24"
EA31-30__	30"
EA31-32__	32"
EA31-36__	36"



## PAPER AND CARDBOARD SPOOL HOLDER

EA33



- Hooks onto the front and rear of EW uprights **3** **3** **4** **4**
- Includes two end brackets and one tube
- Tube diameter: 1"
- Spool is inserted by pivoting one end of the tube, only one person needed
- Color: black
- Capacity: 75lb.

PRODUCT NO.	USABLE WIDTH
EA33-18	12"
EA33-20	14"
EA33-24	18"
EA33-30	24"
EA33-32	28"
EA33-36	30"
EA33-48	42"
EA33-60	54"
EA33-72	66"

NOTE: Not compatible with an EP10, EP12, EP14 panel and EP20 power outlet channel.

## OFFSET SPOOL HOLDER



EA34



- Hooks onto the front and rear of EW uprights **3** **3** **4** **4**
- 3 possible positions from the front of the post using the same product: 7", 9", and 11"
- Allows installation of 22"-diameter rolls from the front of the upright
- Includes two end brackets and one tube
- Tube diameter: 1"
- Spool is inserted by pivoting one end of the tube, only one person needed
- Color: black
- Capacity: 75lb.

PRODUCT NO.	USABLE WIDTH
EA34-18	12"
EA34-20	14"
EA34-24	18"
EA34-30	24"
EA34-32	28"
EA34-36	30"
EA34-48	42"
EA34-60	54"
EA34-72	66"

NOTE: Not compatible with an EP10, EP12, EP14 panel and EP20 power outlet channel.

# ACCESSORIES



## DIMENSIONAL LOGIC

**Uprights height - 8" = recommended height for a hinged panel.**

eg.: A 48"H frame - 8" = a 40"H hinged panel.

### HINGED UTILITY PANEL ER12

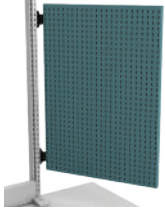

- Hooks onto the side of EW uprights **5**
- Painted steel
- Includes perforations spaced 1" apart c/c for hanging a range of hooks
- Allows the creation of work zones within ergonomic reach areas
- Easy adjustment of the panels at an angle from 0° to 90° toward the user
- Installs on the left or right side of a zone consisting of two uprights and a crossmember
- Adjustable hinge resistance
- Compatible with: WM9F, WM9G, WM9H, WM9J and WM9L light-duty hooks; WM9A and WM9B heavy-duty hooks, **see page 262**
- Compatible with: WM9C rails; WM9D, WM9M, WM9N, WM9Q, WM9P, WM9R and WM9S holders; EA50 mounts; EA52 holders; EA28 and WM21 shelves, **see pages 262-263**
- Capacity: 50lb. (evenly distributed)
- To order: Complete the product number with the height required 22", 28", 34" or 40"

PRODUCT NO.	WIDTH	NO. OF HOLES
ER12-18__	18"	18
ER12-24__	24"	24
ER12-30__	30"	30

**NOTE:** For the use of two back-to-back hinged panels on EW30 double-sided posts, use ER16 add-on hinged panels (utility panel) or ER18 (plastic bin panel) in addition to the ER12, ER14 hinged panels.

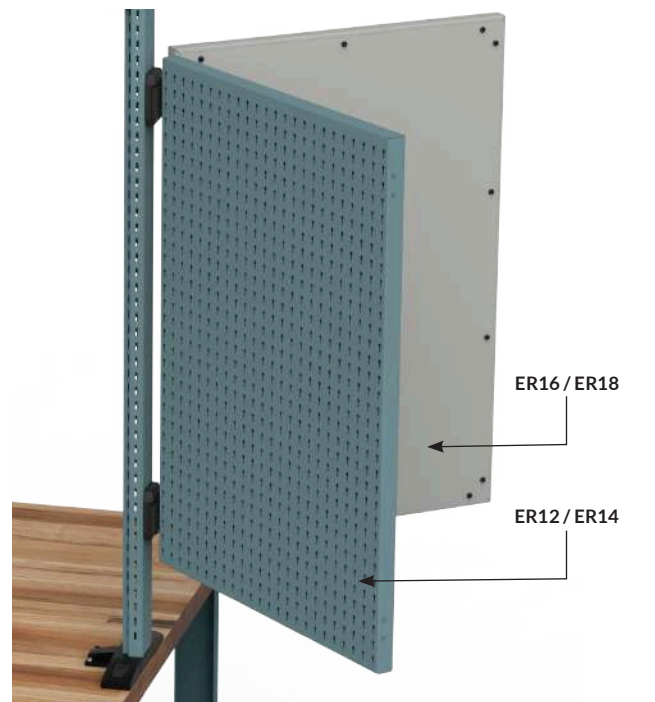

**NOTE:** The color scheme is used for demonstration purposes only.

### PLASTIC BIN HINGED PANEL ER14



- Hooks onto the side of EW uprights **5**
- Painted steel
- Holds RG20 plastic bins, **see page 297**
- Compatible with most brands of plastic bins (with hanging lip) on the market
- Allows the creation of work zones within ergonomic reach areas
- Easy adjustment of the panels at an angle from 0° to 90° toward the user
- Installs on the left or right side of a zone consisting of two uprights and a crossmember
- Adjustable hinge resistance
- Capacity: 50lb. (evenly distributed)
- To order: Complete the product number with the height required 22", 28", 34" or 40"

PRODUCT NO.	WIDTH
ER14-18__	18"
ER14-24__	24"
ER14-30__	30"



EC2102C

## COMPUTER ARTICULATED ARMS

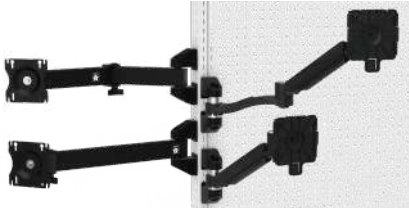

- Hook onto the side **5**, front (or rear) **3 4**
- To learn about all the heavy-duty articulated arm options, [see pages 308-309](#)
- To learn about all the height-adjustable articulated arm options, [see pages 310-311](#)



## SUPPORTS, HOOKS AND 5S ACCESSORIES



- Install by hanging on EP12 utility panels.
- To learn about all available supports, hooks, and 5S accessories options, [see pages 262-264](#)

## UPPER STORAGE CABINETS



Zones **4 4** allow for accessories to be mounted on the rear. To prevent tipping, it's recommended to anchor the workstation to the ground. [See pages 35 and 146.](#)

### STORAGE CABINET WITHOUT DOOR



00

- Hooks onto the front (or rear) of EW uprights **3 3 4 4**
- Includes one bottom shelf
- Compatible with RD05 shelves, adjustable in 1" increments c/c
- Depth: 14"
- Capacity: 200lb.

#### SPECIFY THE WIDTH AND HEIGHT

Width:  
18", 20", 24", 30", 32", 36", 48", 60"

Height:  
18", 21", 24"

ED75- 14 00

### STORAGE CABINET WITH SINGLE INTEGRATED DOOR



01



02

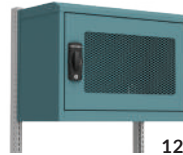

12

- Hooks onto the front (or rear) of EW uprights **3 3 4 4**
- Includes one bottom shelf
- Compatible with RD05 shelves, adjustable in 1" increments c/c
- Single integrated doors (01) have a closed back finish to increase rigidity and enhance aesthetics
- Single integrated polycarbonate doors (02) have excellent impact resistance
- Single integrated mesh doors (12) promotes airflow and provides visibility of the interior without opening
- Opens 180° for full access to items stored inside
- Depth: 14"
- Capacity: 200lb.

NOTE: The 18" height is only available for solid doors.

#### SPECIFY THE WIDTH, HEIGHT, TYPE OF DOOR AND LOCK

Width:  
18", 20", 24", 30", 32", 36"

Height:  
18", 21", 24"

Lock:  
No lock = Empty  
Key = L3  
Digital code (L50) = DL  
Smart (L100) = SL

Door type:  
Solid = 01  
Polycarbonate = 02  
Mesh = 12

ED75- 14

NOTE: The storage cabinets are installed on two uprights and can pass over a common upright.  
Ex: A 30"W cabinet is installed on a 30"W zone. A 60"W cabinet can be installed on a 60"W zone or two 30"W zones.

# ACCESSORIES



Zones 4 allow for accessories to be mounted on the rear. To prevent tipping, it's recommended to anchor the workstation to the ground. See pages 35 and 146.

## STORAGE CABINET WITH DOUBLE INTEGRATED DOORS

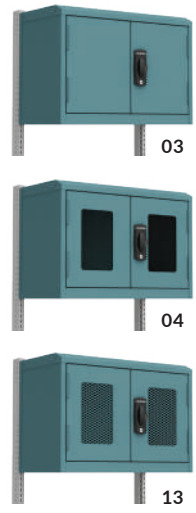

- Hooks onto the front (or rear) of EW uprights 3 3 4 4
- Includes one bottom shelf
- Compatible with RD05 shelves, adjustable in 1" increments c/c
- Opens 180° for full access to items stored inside
- Double integrated doors (03) have a closed back finish to increase rigidity and enhance aesthetics
- Double integrated polycarbonate doors (04) have excellent impact resistance
- Double integrated mesh doors (13) promotes airflow and provides visibility of the interior without opening
- Depth: 14"
- Capacity: 200lb

## STORAGE CABINET WITH SLIDING DOOR



- Hooks onto the front (or rear) of EW uprights 3 3 4 4
- Includes one bottom shelf
- Compatible with RD05 shelves, adjustable in 1" increments c/c
- Integrated sliding doors (07) have a closed back finish to increase rigidity and enhance aesthetics
- Polycarbonate integrated sliding doors (08) have excellent impact resistance
- Integrated sliding mesh doors (14) promotes airflow and provides visibility of the interior without opening
- Depth: 14"
- Capacity: 200lb.

NOTE: The 18" height is only available for solid doors.

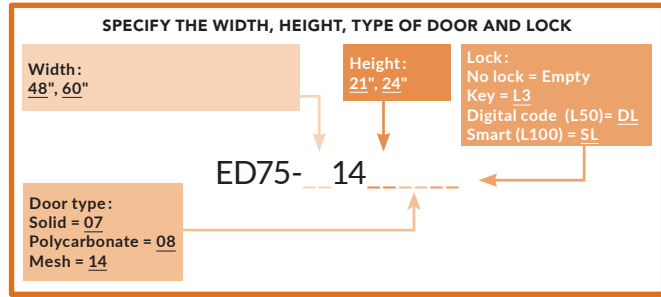
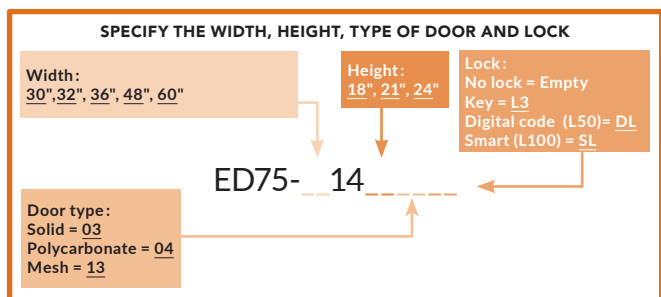

### L3 KEY LOCK



### L50 DIGITAL LOCK AND L100 SMART LOCK



NOTE: The storage cabinets are installed on two uprights and can pass over an common upright.  
Ex: A 30"W cabinet is installed on a 30"W zone. A 60"W cabinet can be installed on a 60"W zone or two 30"W zones.



Zones 3, 4 allow for accessories to be mounted on the rear. To prevent tipping, it's recommended to anchor the workstation to the ground. See pages 35 and 146.

## STORAGE CABINET WITH FLIPPER DOOR

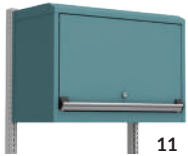

11

- Hooks onto the front (or rear) of EW uprights 3, 3, 4, 4
- Includes one bottom shelf
- Compatible with RD05 shelves, adjustable in 1" increments c/c
- Provides maximum clearance for handling items stored in the cabinet
- Depth: 14"
- Capacity: 200lb.

### SPECIFY THE WIDTH, HEIGHT AND LOCK

Width:  
18", 20", 24", 30", 32", 36", 48", 60"

Height:  
18", 21", 24"

Lock:  
No lock = Empty  
Key = L3  
Digital code (L50) = DL  
Smart (L100) = SL

ED75- 14 11

## SHELF

RD05



- Includes a backstop to prevent objects from falling to the bottom of the cabinet
- Adjustable in 1" increments c/c
- Load capacity: up to 100lb. evenly distributed
- Compatible with SH52 dividers, see page 173

PRODUCT NO.	W×D
RD05-1812	18"×12"
RD05-2012	20"×12"
RD05-2412	24"×12"
RD05-3012	30"×12"
RD05-3212	32"×12"
RD05-3612	36"×12"
RD05-4812	48"×12"
RD05-6012	60"×12"

## COMPUTER CABINET



50

- Hooks onto the front (or rear) of EW uprights 3, 3, 4, 4
- The fan with filtration screen creates positive pressure inside the cabinet
- The monitor mount creates room for a computer and monitor in the same space
- Includes a power bar with six 15A outlets (for 15A circuit)
- Height: 21"
- Depth: 14"
- Capacity: 200lb.

### SPECIFY THE WIDTH

Width:  
24", 30", 32", 36"

ED76- 142150

## COMPUTER CABINET WITH KEYBOARD AND MOUSE TRAY



52

- Hooks onto the front (or rear) of EW uprights 3, 3, 4, 4
- The fan with filtration screen creates positive pressure inside the cabinet
- The monitor mount creates room for a computer and monitor in the same space
- Includes a power bar with six 15A outlets (for 15A circuit)
- The keyboard and mouse tray can be tucked away under the cabinet when not in use
- Height: 21"
- Depth: 14"
- Capacity: 200lb.

### SPECIFY THE WIDTH

Width:  
24", 30", 32", 36"

ED76- 142152

NOTE: The storage cabinets are installed on two uprights and can pass over an common upright.  
Ex: A 30"W cabinet is installed on a 30"W zone. A 60"W cabinet can be installed on a 60"W zone or two 30"W zones.

# ACCESSORIES



Zones 4 allow for accessories to be mounted on the rear. To prevent tipping, it's recommended to anchor the workstation to the ground. See pages 35 and 146.

## COMPUTER CABINET WITH POLYCARBONATE DOOR



51

- Hooks onto the front (or rear) of EW uprights 3 3 4 4
- The fan with filtration screen creates positive pressure inside the cabinet
- The monitor mount creates room for a computer and monitor in the same space
- Includes a power bar with six 15A outlets (for 15A circuit)
- Polycarbonate door provides excellent impact resistance
- Height: 21"
- Depth: 14"
- Capacity: 200lb.

## COMPUTER CABINET WITH POLYCARBONATE DOOR AND KEYBOARD AND MOUSE TRAY



53

- Hooks onto the front (or rear) of EW uprights 3 3 4 4
- The fan with filtration screen creates positive pressure inside the cabinet
- The monitor mount creates room for a computer and monitor in the same space
- Includes a power bar with six 15A outlets (for 15A circuit)
- The keyboard and mouse tray can be tucked away under the cabinet when not in use
- Polycarbonate door provides excellent impact resistance
- Height: 21"
- Depth: 14"
- Capacity: 200lb.

### SPECIFY THE WIDTH

Width:  
24", 30"

ED76-\_\_142151L3

### SPECIFY THE WIDTH

Width:  
24", 30"

ED76-\_\_142153L3

## LED LIGHT FOR CABINET

RD45



- For installation underneath an ED75 or ED76\* cabinet
- Emits a brighter light than fluorescent tubes and is more energy efficient
- Color temperature:
- 5000-6000K (daylight white)
- For a motion sensor (3 switch positions available), complete the product number with MS, e.g., RD45-2414MS for an LED light for cabinet with motion sensor

PRODUCT NO.	HOUSING WIDTH	REAL LIGHT WIDTH
RD45-1814__	18" and 20"	15"
RD45-2414__	24"	21"
RD45-3014__	30"	27"
RD45-3614__	36"	33"
RD45-4814__	48"	45"
RD45-6014__	60"	57"

NOTES: The motion sensor is not available for 18" widths.

\*Not compatible with computer cabinets with keyboard and mouse tray.

## ESD PROTECTION

### ESD PROTECTION KIT FOR WORKSTATIONS

EA90-01



Grounding wrist strap  
EA96-01



Wrist strap double socket  
EA97-01

- Basic kit for grounding the operator and work surface
- Includes an EA96 wrist strap, EA97 wrist strap socket, EA95 grounding cord, and EA99 grounding plug
- Grounding wrist strap includes a 6' cord with 1MΩ resistance
- Grounding cord includes #10 screw eyelet and necessary hardware

PRODUCT NO.  
EA90-01



Grounding plug  
EA99-01



Grounding cord  
EA95-01

### GROUNDING CORD 6'

EA94-01

### DISSIPATIVE PAINT



- Connects all components on the workstation to a common grounding point
- Includes eyelets on both ends for #10 screws
- Includes one #10-32 x 2" screw, one 10-32 nut, one #10 x 5/8" tapping screw, and two #10 serrated washers
- Dissipates electrical charges that can damage electronic components
- 6' long

PRODUCT NO.  
EA94-01



- Special paint dissipates electric charges (Black 090)

NOTE: Contact Customer Service for ESD paint prices.

### CONDUCTIVE PLASTIC BINS



297

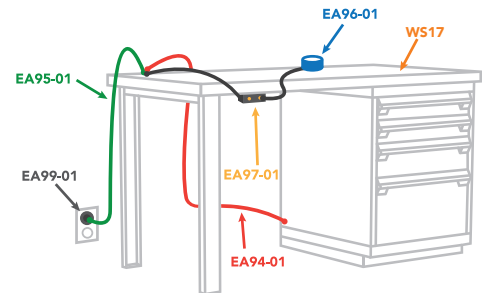
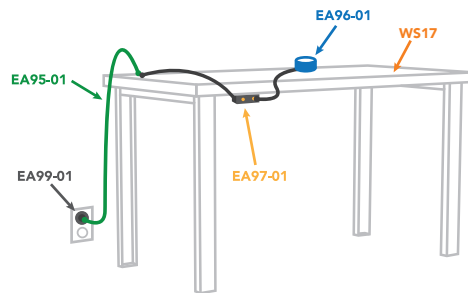

### DISSIPATIVE TOP



144

