



SOLUZIONI PER L'EDILIZIA
SOLUTIONS FOR BUILDING



BUTTI

PENSATO PER DURARE



BUTTI

PENSATO PER DURARE

SOLLEVAMENTO | LIFTING

08



SOLLEVAMENTO E MOVIMENTAZIONE DI CALCESTRUZZO E INERTI LIFTING AND HANDLING OF CONCRETE AND AGGREGATES

23



MOVIMENTAZIONE E STOCCAGGIO | HANDLING AND STORAGE

31



ACCESSORI PER L'EDILIZIA E LA PULIZIA BUILDING AND CLEANING ACCESSORIES

45



- 08 FORCHE | CRANE FORKS
- 12 COPPIA DI TRAVERSE PER SOLLEVAMENTO | PAIR OF CROSSBEAMS FOR LIFTING
- 13 DISPOSITIVI DI PRESA POSITIVI SECONDARI: RETE E SICURPAK | SECONDARY POSITIVE SOCKET DEVICES: NET AND SICURPAK
- 14 GANCI DI CARICO E BILANCINO | LIFTING HOOKS AND LIFTING BEAM
- 15 SERVIPAK | SERVIPAK
- 15 PALLETS PER BOMBOLE | PALLETS FOR GAS CYLINDER
- 16 PINZE | GRABS
- 18 IMBRAGHI A CATENA | HARNESS CHAINS & ONE LEG SLING
- 19 BRACHE IN POLIESTERE | POLYESTER FLAT WEBBING SLINGS
- 20 CESTONI SOLLEVABILI | LIFTING MAN BASKETS
- 22 CONTENITORE PER MANUTENZIONE AEREA | BASKET FOR AERIAL MAINTENANCE

- 23 BENNE CONICHE A SCARICO CENTRALE | CONICAL BUCKETS WITH CENTRAL UNLOADING
- 24 BENNE CLI CONICHE A SCARICO CENTRALE E LATERALE | CLI CONICAL BUCKETS WITH CENTRAL & SIDE UNLOADING
- 25 BENNE SUPER RIBASSATE A SCARICO CENTRALE | SUPERLOWERED CONICAL BUCKETS WITH CENTRAL UNLOADING
- 25 PORTA MALTA | MORTAR HOLDER
- 26 BENNE EUROPA CONICHE CON TUBO DI SCARICO | EUROPA CONICAL BUCKETS WITH RUBBER HOSE UNLOADING
- 26 BENNE CULLA CON TUBO DI SCARICO | LAYDOWN BUCKET WITH RUBBER HOSE UNLOADING
- 27 BENNE ELICOTTERO | CONICAL BUCKETS FOR HELICOPTER
- 28 BENNE AUTOSCARICANTI | SELF DUMPING BIN
- 29 BENNE ELEVATORE | TIPPING BIN
- 29 BENNA SABBIA CON RIBALTAMENTO AUTOMATICO | SAND BUCKET WITH AUTOMATIC ROLL OVER
- 30 BENNE QUADRA CON SEDI FORCHE | SQUARED BUCKETS WITH FORKLIFT SEATS
- 30 BENNA BICICLETTA | BARROW WHEEL

- 31 CONTAINER MULTIBENNA | MULTIBENNA CONTAINER
- 32 PORTA ATTREZZI | TOOL HOLDERS
- 35 CONTENITORI IN METALLO, IN POLIETILENE E IN RETE | METAL, POLYETHYLENE AND MESH CONTAINERS
- 38 CONTENITORI A FONDO APRIBILE "COMPACT" | CONTAINERS WITH OPENABLE BOTTOM "COMPACT"
- 40 CONTENITORI RIBALTABILI "PERTUTTO" | TIPPING CONTAINERS "PERTUTTO"
- 41 TRAMOGGIA E CONTENITORI PORTA "BIG-BAG" | "BIG-BAG" HOPPER AND CONTAINERS
- 42 SCAFFALATURE INDUSTRIALI | INDUSTRIAL SHELVINGS
- 43 SCOPE INDUSTRIALI | INDUSTRIAL BROOMS
- 44 VASCHE, DEPOSITI E ACCESSORI PER CISTERNE | SPILL CONTAINMENT PALLETS, CONTAINER AND ACCESSORIES FOR TANKS

- 45 POMPE A PRESSIONE | PRESSION SPRAYERS
- 46 PORTA SECCHI | BUCKETS HOLDER
- 47 CAVALLETTI | TRESTLES
- 47 BARELLE D60 | STACKING STILLAGE D60
- 48 TRANSPALLET | TRANSPALLET
- 48 ASSORBENTI | ABSORBENTS
- 48 ACCESSORI DI SICUREZZA PER IL LAVORATORE | ACCESSORIES FOR WORKER SAFETY
- 49 TETTOIA PER PROTEZIONE BETONIERA | CANOPY FOR CONCRETE MIXER COVERING
- 49 MATITA PROFESSIONALE E MATITA "SEMPRE PRONTA" | PROFESSIONAL PENCIL AND "SEMPRE PRONTA" PENCIL
- 49 DOPPIO METRO | FOLDING RULER
- 50 SPAZZANEVE, SPARGISALE, FRESANEVE | SNOWPLOUGH, SALT SPREADER, SNOW BLOWER

BUTTI

PROGETTIAMO CON ESPERIENZA, COSTRUIAMO CON PROFESSIONALITÀ

Progettiamo e realizziamo attrezzature per movimentare e contenere ogni tipo di materiale, rendendo più veloce e sicuro il lavoro in vari settori.

Possiamo proporre le soluzioni innovative che ci differenziano perché non ci siamo mai accontentati di limitarci a "produrre", ma abbiamo sempre dato grande importanza alla fase di progetto.

Il nostro catalogo non offre solo i prodotti che il mercato richiede, ma punta soprattutto a proporre soluzioni ad esigenze che ancora non hanno una risposta: la nostra forza è la continua innovazione, la costante ricerca di qualità, la grande flessibilità tecnica e commerciale che ci pone come interlocutore privilegiato per le aziende che cercano soluzioni efficaci ed immediate.



WE DESIGN WITH EXPERIENCE, WE BUILD WITH PROFESSIONALISM

We design and manufacture equipment to handle and contain all types of materials, making work faster and safer in various sectors.

We can propose innovative solutions that differentiate us because we have never contented ourselves with merely "producing", but we have always given great importance to the project phase.

Our catalogue does not only offer the products that the market requires, but aims above all to offer solutions to needs that do not have an answer yet: our strength is the continuous innovation, the constant research for quality, the great technical and commercial flexibility that makes us a privileged interlocutor for companies looking for effective and immediate solutions.

I NOSTRI CONTATTI | OUR CONTACTS:

Via Mayer 13 - 24034 Cisano Bergamasco (BG) - Italy | Tel. +39 035 787300 - +39 035 787005 - Fax +39 035 787322 | butti@butti.it - www.butti.it



30 ANNI DI ESPERIENZA

MODERNO STABILIMENTO SU UN'AREA DI 10.000 METRI QUADRI

REPARTO INTERNO RICERCA E SVILUPPO

MAGAZZINO CON PRODOTTI IN PRONTA CONSEGNA

REPARTO INTERNO LAVORAZIONE E REALIZZAZIONE PRODOTTI FINITI

REPARTO INTERNO MARKETING E COMUNICAZIONE

NORMATIVE DI RIFERIMENTO: D.LGS 81/2008 - EN 14502-1 - EN13155

NB: Le immagini dei prodotti sono puramente indicative e potrebbero pertanto non essere perfettamente rappresentative delle caratteristiche del prodotto.
La BUTTI si riserva la facoltà di modificare in qualsiasi momento e senza alcun preavviso l'esecuzione e le dimensioni dei prodotti illustrati.



DOVE SIAMO | OUR LOCATION:

Ci trovate tra Lecco e Bergamo, facilmente raggiungibili da Monza e Milano | You can find us between Lecco and Bergamo, easily reachable from Monza and Milan

**IL NOSTRO LAVORO
MIGLIORA IL VOSTRO LAVORO**

Le tre linee di prodotto che proponiamo affrontano settori diversi – edilizia, industria, recycling – ma hanno in comune la necessità di strutture solide ed affidabili. La nostra trentennale esperienza ci consente di impostare le linee di produzione assicurando un costante controllo, dal progetto alla finitura. Per questo motivo i nostri prodotti non sono un costo per l’azienda, ma un investimento per migliorare sicurezza e produttività.

**OUR WORK
IMPROVES YOUR WORK**

The three product lines we offer address different sectors - construction, industry, recycling - but they have in common the need of solid and reliable structures. Our thirty years of experience allow us to set up production lines ensuring constant control, from design to finishing. For this reason, our products are not a cost for the company, but an investment to improve safety and productivity.



30 YEARS OF EXPERIENCE

A MODERN PLANT ON AN AREA OF 10,000 SQUARE METERS

INTERNAL RESEARCH AND DEVELOPMENT DEPARTMENT

WAREHOUSE WITH PRODUCTS READY ON STOCK

INTERNAL DEPARTMENT FOR PROCESSING AND CONSTRUCTION OF FINISHED PRODUCTS

INTERNAL MARKETING AND COMMUNICATION DEPARTMENT

REFERENCE REGULATIONS: D.LGS 81/2008 - EN 14502-1 – EN13155



NB: The product pictures are purely indicative and may not exactly represent the product features. BUTTI reserves the right to modify, at any time and without notice, the execution and the sizes of the products shown.

ITALIA - AUTOBILANCIATE
ITALIA - SELF BALANCING

MODELLO MODEL	DIMENSIONI DIMENSIONS mm					TARA TARE kg	PORTATA LOAD CAPACITY kg	PESO PIENO CARICO TOTAL FULL LOAD WEIGHT kg
	L	P	H1	H2	G			
6811152	1200	1190	2100	1250	1000	155	1500	1655
6811202	1200	1200	2100	1250	1000	187	2000	2187

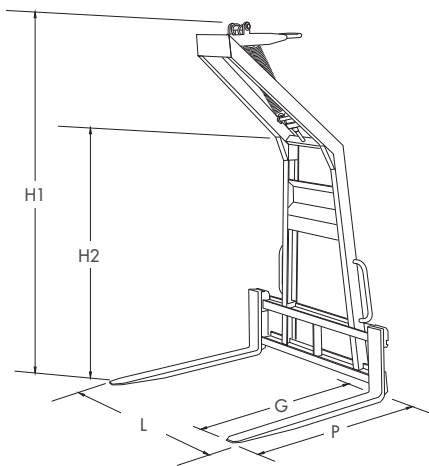

YOUTUBE VIDEO

• Forche forgiate
Forged steel forks



• Carter di sicurezza
Safety carter

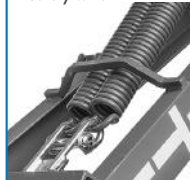

• Sistema di chiusura e raccogliatore catena
Closing system & load binder chain



• Rapido sistema di chiusura brevettato
Patented quick fastening system



• Ganci per rete di sicurezza
Net hooks for safety net



ITALIA - AUTOBILANCIATE CON GANCI PER RETE DI SICUREZZA
ITALIA - SELF BALANCING WITH HOOKS FOR SAFETY NET

MODELLO MODEL	DIMENSIONI DIMENSIONS mm					TARA TARE kg	PORTATA LOAD CAPACITY kg	PESO PIENO CARICO TOTAL FULL LOAD WEIGHT kg
	L	P	H1	H2	G			
6811152D	1200	1190	2100	1250	1000	160	1500	1660
6811202D	1200	1200	2100	1250	1000	192	2000	2192

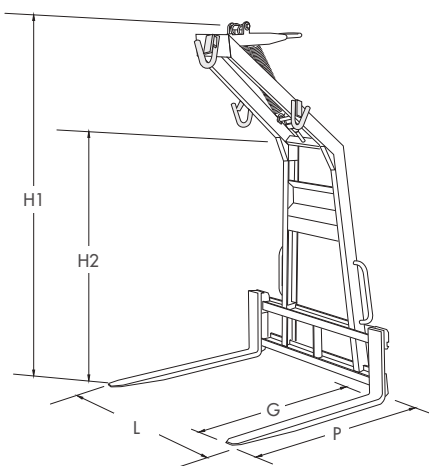

ACCESSORI | ACCESSORIES



99C165
RETE DI SICUREZZA PER FORCHE CON GANCI CON FONDO RINFORZATO (3,80x3,80 m)
ISTRUZIONI D'USO PAG. 13
SAFETY NET FOR CRANE FORKS WITH HOOKS AND REINFORCED BOTTOM (3,80x3,80 m)
INSTRUCTIONS FOR USE PG. 13



YOUTUBE VIDEO

UNIVERSAL - AUTOBILANCIATE E CON FORCHE AUTOLIVELLANTI
UNIVERSAL - SELF BALANCING AND WITH SELF-LEVELING FORKS

MODELLO MODEL	DIMENSIONI DIMENSIONS mm					TARA TARE kg	PORTATA LOAD CAPACITY kg	PESO PIENO CARICO TOTAL FULL LOAD WEIGHT kg
	L	P	H1	H2	G			
681U152	330/1350	1150	1990	1350	1000	133	1500	1633
681U202	330/1350	1150	1990	1350	1000	147	2000	2147
681U252	330/1350	1150	1990	1350	1000	159	2500	2659



- Forche forgiate
Forged steel forks



- Forche forgiate autolivellanti
Forged steel self-leveling forks



- Apertura veloce e chiusura a compasso
Fast compass opening & closing

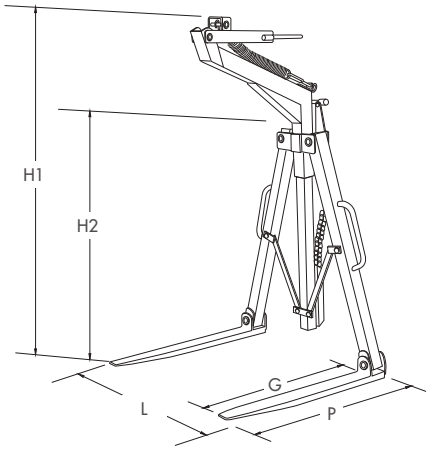

UNIVERSAL - AUTOBILANCIATE, CON FORCHE AUTOLIVELLANTI E GANCI PER RETE DI SICUREZZA
UNIVERSAL - SELF BALANCING, WITH SELF-LEVELING FORKS AND HOOKS FOR SAFETY NET

MODELLO MODEL	DIMENSIONI DIMENSIONS mm					TARA TARE kg	PORTATA LOAD CAPACITY kg	PESO PIENO CARICO TOTAL FULL LOAD WEIGHT kg
	L	P	H1	H2	G			
681U152D	330/1350	1150	1990	1350	1000	142	1500	1642
681U202D	330/1350	1150	1990	1350	1000	157	2000	2157
681U252D	330/1350	1150	1990	1350	1000	171	2500	2671



- Ganci per rete di sicurezza
Net hooks for safety net

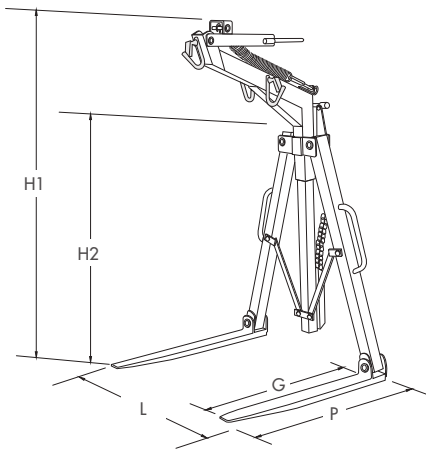

ACCESSORI | ACCESSORIES



99C165
RETE DI SICUREZZA PER FORCHE CON GANCI CON FONDO RINFORZATO (3,80x3,80 m)
ISTRUZIONI D'USO PAG. 13
SAFETY NET FOR CRANE FORKS WITH HOOKS AND REINFORCED BOTTOM (3,80x3,80 m)
INSTRUCTIONS FOR USE PG. 13



99C064
TERZO DENTE CENTRALE NON PORTANTE DISPONIBILE A RICHIESTA
A NON LOAD BEARING CENTRAL 3° FORK AVAILABLE ON REQUEST

GRUCAR
GRUCAR

MODELLO MODEL	DIMENSIONI DIMENSIONS mm					TARA TARE kg	PORTATA LOAD CAPACITY kg	PESO PIENO CARICO TOTAL FULL LOAD WEIGHT kg
	L	P	H1	H2	G			
681F202	515/1000	1170	1630/2180	1050/1600	1000	148	2000	2148
681F252	515/1000	1170	1630/2180	1050/1600	1000	155	2500	2655
681F302	570/1000	1210	1730/2290	1085/1645	1000	225	3000	3225

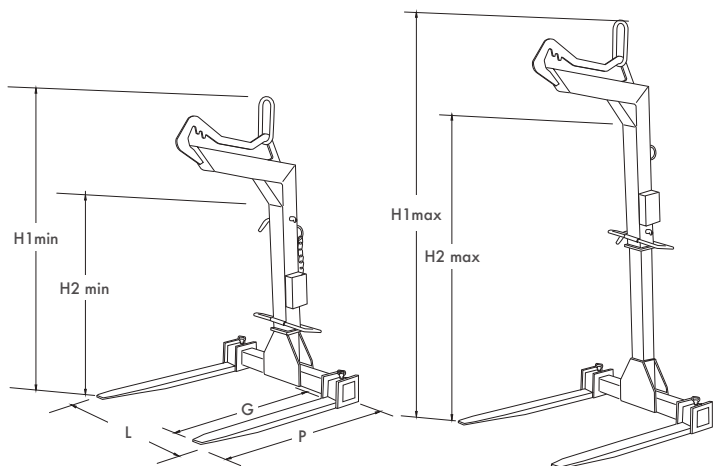

YOUTUBE VIDEO

- Forche forgiate
Forged steel forks



- Sistema di chiusura e raccogliatore catena
Closing system & load binder chain



- Le forche Grucar sono dotate di sedi forche per la movimentazione e lo stoccaggio della sola forca (senza carico)
The Grucar forks are equipped with forks for the handling and storage only of the fork (without load)



GRUCAR - CON GANCI PER RETE DI SICUREZZA
GRUCAR - WITH HOOKS FOR SAFETY NET

MODELLO MODEL	DIMENSIONI DIMENSIONS mm					TARA TARE kg	PORTATA LOAD CAPACITY kg	PESO PIENO CARICO TOTAL FULL LOAD WEIGHT kg
	L	P	H1	H2	G			
681F202D	515/1000	1170	1630/2180	1050/1600	1000	159	2000	2159
681F252D	515/1000	1170	1630/2180	1050/1600	1000	166	2500	2666
681F302D	570/1000	1210	1730/2290	1085/1645	1000	235	3000	3235

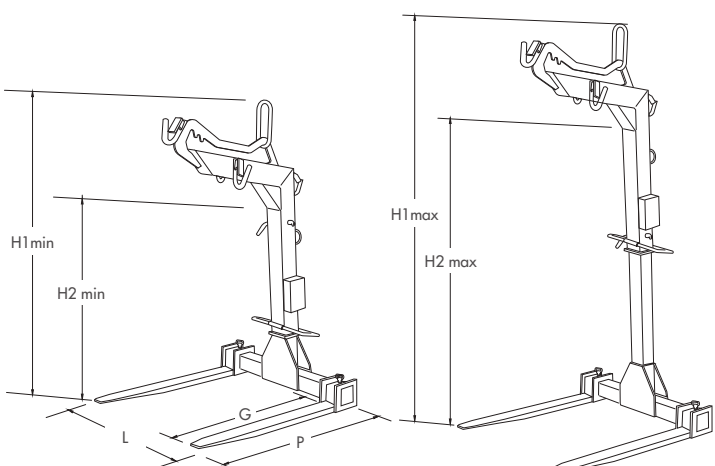

- Ganci per rete di sicurezza
Net hooks for safety net



ACCESSORI | ACCESSORIES



99C165
RETE DI SICUREZZA PER FORCHE CON GANCI CON FONDO RINFORZATO (3,80x3,80 m)
ISTRUZIONI D'USO PAG. 13
SAFETY NET FOR CRANE FORKS WITH HOOKS AND REINFORCED BOTTOM (3,80x3,80 m)
INSTRUCTIONS FOR USE PG. 13

GRUCAR PER GRU AUTOCARRI PER IL SOLLEVAMENTO DI DUE COLLI SOVRAPPosti
 GRUCAR FOR CRANE TRUCKS FOR THE RAISING OF TWO OVERLAPPING PACKAGES

MODELLO MODEL	DIMENSIONI DIMENSIONS mm					TARA TARE kg	PORTATA LOAD CAPACITY kg	PESO PIENO CARICO TOTAL FULL LOAD WEIGHT kg
	L	P	H1	H2	G			
681F182	515/1000	1170	2090/3150	1550/2610	1000	172	1800	1972

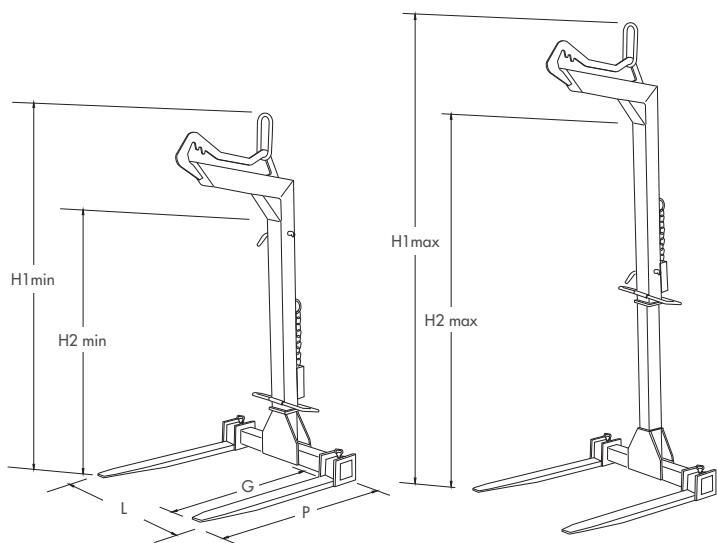

- Forche forgiate
Forged steel forks

- Esempio di utilizzo con pallets
Example of use with pallets



- Le forche Grucar sono dotate di sedi forche per la movimentazione e lo stoccaggio della sola forca (senza carico)
The Grucar forks are equipped with forks for the handling and storage only of the fork (without load)



GRUCAR MOD. AMERICA - AUTOBILANCIATE
 GRUCAR FORKS MOD. AMERICA - SELF-BALANCING

MODELLO MODEL	DIMENSIONI DIMENSIONS mm					TARA TARE kg	PORTATA LOAD CAPACITY kg	PESO PIENO CARICO TOTAL FULL LOAD WEIGHT kg
	L	P	H1	H2	G			
681F252U	565/1000	1375	2085/2920	1375/2210	1200	250	2500	2750

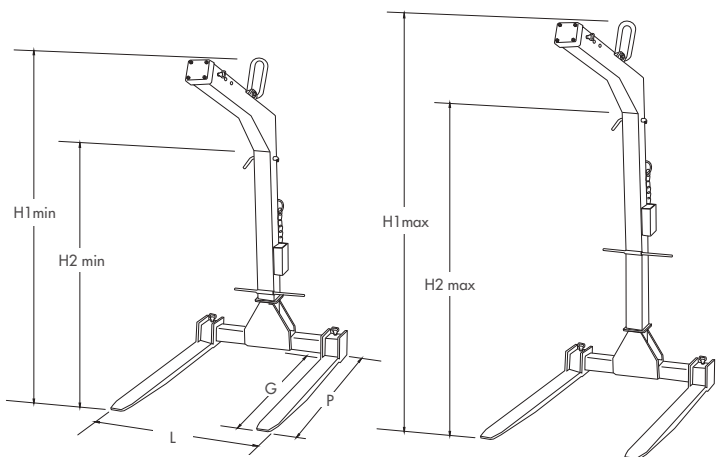

- Sistema di autobilanciamento mod. America
Self-balancing system mod. America



ACCESSORI | ACCESSORIES



MODELLO MODEL	CATENA CHAIN Ø	LUNGHEZZA LENGHT m	PORTATA LOAD CAPACITY kg
591D1	10	1	3150
591F1	13	1	5300

SPECIAL - ULTRA LEGGERE
SPECIAL - EXTRA LIGHT

MODELLO MODEL	DIMENSIONI DIMENSIONS mm					TARA TARE kg	PORTATA LOAD CAPACITY kg	PESO PIENO CARICO TOTAL FULL LOAD WEIGHT kg
	L	P	H1	H2	G			
681S062	630	1030	1390	1050	950	35	600	635
681S082	630	1030	1590	1250	950	48	800	848

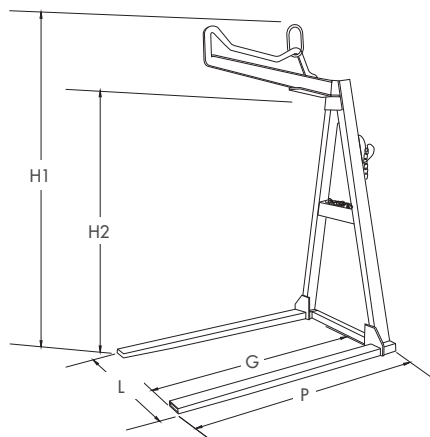

• PESA SOLO 35 KG
WEIGHT ONLY
35 KG

• Raccoglitore catena di
chiusura
Load binder chain



COPPIA DI TRAVERSE PER SOLLEVAMENTO
PAIR OF CROSSBEAMS FOR LIFTING

MODELLO MODEL	DIMENSIONI DIMENSIONS mm			PORTATA COPPIA CHARGE IN PAIRS kg
	L	P	H	
849AS10	1280	80	50	2000



• Gancio di presa
orientabile
Swivel grip hooks



ACCESSORI | ACCESSORIES



CATENA 4 RAMI
PER TRAVERSE
4 LEGS CHAIN
FOR CROSSBEAMS

MODELLO MODEL	CATENA CHAIN Ø	LUNGHEZZA LENGHT m	PORTATA LOAD CAPACITY kg
594A4	6	4	3000



Le forche di sollevamento, nel caso in cui debbano sollevare materiale sfuso detto **carico NON unitario** (ad esempio mattoni), per movimentare il carico devono avvalersi di un dispositivo di presa positivo secondario, come una rete di sicurezza o una cesta.

I dispositivi in questione servono quindi ad impedire che il carico non unitario sollevato tramite la forca venga rilasciato in tutto o in parte durante la movimentazione.

Più precisamente, si definiscono:

- 1) **carico unitario**: il carico composto da elementi tenuti insieme con uno o più mezzi (es. reggette o involucri) è formato e attrezzato per la movimentazione, il trasporto l'accatastamento e lo stoccaggio in una sola unità - secondo UNI EN ISO 445:2013;
- 2) **carico non unitario**: carico che non ha i requisiti per essere definito unitario come carichi non pallettizzati, carichi pallettizzati mancanti di involucro termoretraibile e/o di reggetta, carichi pallettizzati con involucro e/o reggetta danneggiati o fuori vita utile e i carichi posti su pallet a perdere;
- 3) **involucro termoretraibile**: involucro in plastica per carico unitario, usato nella sua vita utile (generalmente 6 mesi), che, riscaldato, si ritira per garantire una migliore stabilità e sicurezza del carico - secondo UNI EN ISO 445:2013;
- 4) **pallet riutilizzabile**: "appositamente costruito dal produttore sulla base dei requisiti minimi e che può essere riutilizzato purché non superi il suo carico nominale (R) originario per la destinazione d'uso prevista" - definizione dalla UNI EN ISO 445:2013;
- 5) **pallet a perdere**: "pallet destinato ad essere scartato dopo un solo ciclo di utilizzo, questo pallet non può essere utilizzato per la movimentazione in quota dei carichi" - definizione dalla UNI EN ISO 445:2001 punto 9.1.

È responsabilità dell'azienda che esegue l'operazione di sollevamento di accertarsi della natura del carico da sollevare prima di effettuare qualsiasi operazione di sollevamento, in modo da utilizzare i dispositivi idonei al sollevamento del carico. In caso di dubbi bisogna richiedere al fornitore dei materiali da sollevare le caratteristiche tecniche dell'involucro e/o della reggetta per valutarne l'idoneità.

Butti, mettendo sempre al primo posto la sicurezza degli operatori e tenendo sempre presente la normativa di riferimento, ha sviluppato i seguenti due dispositivi di presa positivi secondari: rete di sicurezza e Sicurpak.

The lifting forks, in the case in which they have to lift loose material called **NOT unitary load** (for example bricks), to move the load must be used a secondary positive gripping device, such as a safety net or a basket. These devices serve to prevent the non-unitary load lifted by the fork of being released partially or entirely during handling.

More precisely, they define:

- 1) **unit load**: the load composed of elements held together with one or more means (eg straps or casings) is formed and equipped for handling, transporting, stacking and storage in one unit - according to UNI EN ISO 445:2013;
- 2) **non-unitary load**: load that does not have the requisites to be defined unitary such as non-palletized loads, palletized loads missing wrapping and/or strap, palletized loads with casing and/or strapping damaged or out of service life and loads placed on disposable pallets;
- 3) **shrink wrapping**: plastic casing for unitary load, used in its useful life (generally 6 months), which, when heated, withdraws to ensure better stability and safety of the load - according to UNI EN ISO 445:2013;
- 4) **reusable pallet**: "appropriately constructed by the manufacturer on the basis of minimum requirements and which can be re-used provided it does not exceed its original nominal load (R) for the intended use" - definition from UNI EN ISO 445:2013;
- 5) **disposable pallets**: "pallet destined to be discarded after only one cycle of use, this pallet can not be used for handling loads" - definition from UNI EN ISO 445:2001 point 9.1.

It is the responsibility of the company performing the lifting operation to ascertain the nature of the load to be lifted before carrying out any lifting operation, in order to use the devices suitable for lifting the load. In case of doubt, ask the supplier of the materials to be lifted the technical characteristics of the casing and / or the strap to assess its suitability.

Butti company, always putting the safety of the operators in the first place and always keeping in mind the reference legislation, has developed the following two positive secondary gripping devices: safety net and Sicurpak.

RETE DI SICUREZZA IN NYLON CON FONDO RINFORZATO
SAFETY NYLON NET WITH REINFORCED BOTTOM

MODELLO MODEL	DIMENSIONI DIMENSIONS m
99C165	3,80x3,80



SEQUENZA DI SOLLEVAMENTO PER CARICO NON UNITARIO
LIFT SEQUENCE FOR NON-UNITARY LOAD

1



Stendere accuratamente la rete
Carefully spread the net

2



Posizionare il carico sopra la rete senza appoggiarlo
Place the load on the net without leaning it against

3



Inserire gli occhielli negli appositi ganci di sicurezza
Insert the eyelets in the appropriate safety hooks

4



Sollevare in sicurezza
Lift safely

CESTA SICURPAK PER IL SOLLEVAMENTO DEI BANCALI IN SICUREZZA, CON QUALSIASI FORCA REGOLABILE
SICURPAK BASKET FOR SAFELY PALLET UPLIFTING, WITH ADJUSTABLE FORKS

MODELLO MODEL	DIMENSIONI DIMENSIONS mm			TARA TARE kg	PORTATA LOAD CAPACITY kg	PESO PIENO CARICO TOTAL FULL LOAD WEIGHT kg
	L	P	H			
386	1400	1500	1400	130	2000	2130



SEQUENZA DI SOLLEVAMENTO PER CARICO NON UNITARIO
LIFT SEQUENCE FOR NON-UNITARY LOAD

1



Posizionare la forca con il carico all'interno della gabbia
Place the crane fork with the load inside the cage

2



Chiudere i due maniglia laterali
Close the two side handles

3



Utilizzare i sistemi di sicurezza in dotazione e chiudere lo sportello
Use the supplied security systems and close the door

4



Sollevare sempre agganciandosi alla forca
Always raise by hooking the crane fork

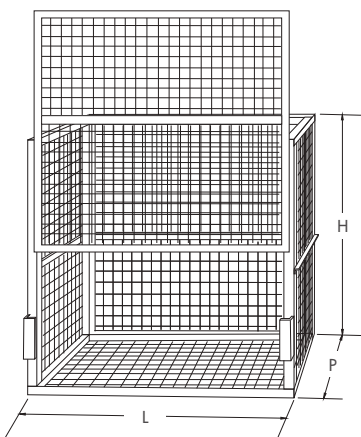

esempio di utilizzo, forca non compresa
example of use, crane fork not included

// GANCIO DI CARICO
LIFTING HOOK

MODELLO MODEL	DIMENSIONI DIMENSIONS mm			PORTATA LOAD CAPACITY kg
	L	P	H	
921	630	250	250	2000

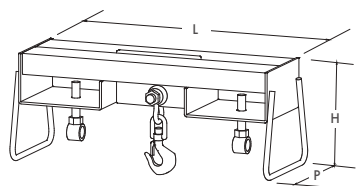

// QUOTE SEDI FORCHE INTERNE | INTERNAL FORK SEATS DIMENSIONS

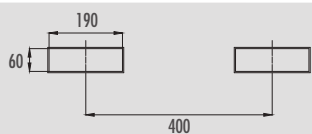

// GANCIO DI CARICO
LIFTING HOOK

MODELLO MODEL	DIMENSIONI DIMENSIONS mm			PORTATA LOAD CAPACITY kg
	L	P	H	
921Q40	1025	320	400	4000

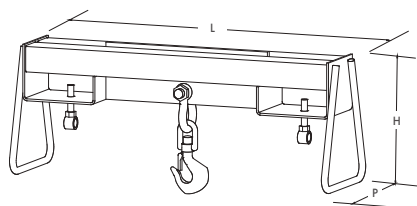

// QUOTE SEDI FORCHE INTERNE | INTERNAL FORK SEATS DIMENSIONS

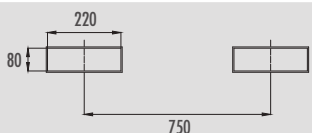

// BILANCINO PORTA "BIG-BAG" CON SEDI FORCHE
"BIG-BAG" LIFTING BEAM WITH FORK SEATS

MODELLO MODEL	DIMENSIONI ESTERNE EXTERNAL DIMENSIONS mm			PORTATA LOAD CAPACITY kg
	L	P	H	
564SBX	1070	1160	350	2000

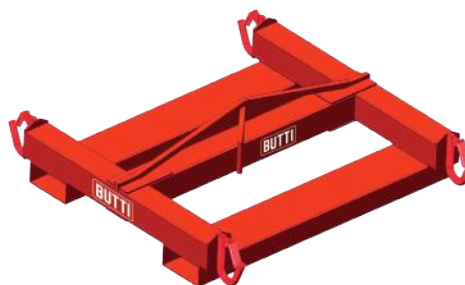
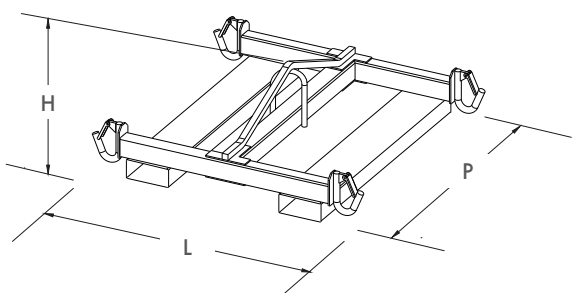

// QUOTE SEDI FORCHE INTERNE | INTERNAL FORK SEATS DIMENSIONS

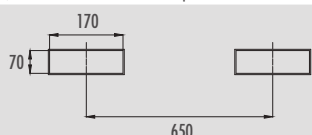

////// CESTA SERVIPAK CON SPORTELLO SFILABILE
SERVIPAK BASKET WITH SLIP OFF DOOR

MODELLO MODEL	DIMENSIONI DIMENSIONS mm			TARA TARE kg	PORTATA LOAD CAPACITY kg	PESO PIENO CARICO TOTAL FULL LOAD WEIGHT kg
	L	P	H			
392	1500	1350	1470	240	2000	2240

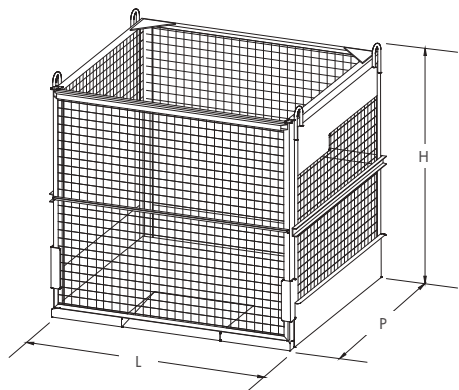

• Ideato per il sollevamento dei materiali in sicurezza
Designed for safely lifting of material



• Con sportello sfilabile
With slip off door



• Punti di presa per i ganci di sollevamento
Grip points for the lifting hooks

• Scivolo per carico e scarico con transpallet
Chute for loading and unloading with transpallet

////// PALLET PER BOMBOLE
PALLET FOR GAS CYLINDER

MODELLO MODEL	DIMENSIONI DIMENSIONS mm			PORTATA CAPACITY
	L	P	H	
8870I1121X	1030	860	960	12 bombole 12 cylinders

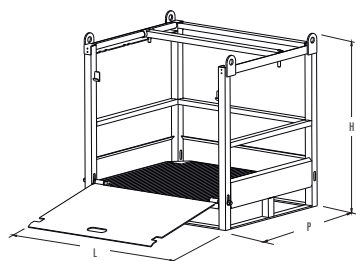

• Zincato a caldo
Hot-dip galvanized

• Con ganci di sollevamento
With lifting hooks and

• Con sedi forche
With fork seats

• Scivolo incluso
Slide included

////// PALLET PER BOMBOLE
PALLET FOR GAS CYLINDER

MODELLO MODEL	DIMENSIONI DIMENSIONS mm			PORTATA CAPACITY
	L	P	H	
8870I0811	860	650	1240	4 bombole 4 cylinders

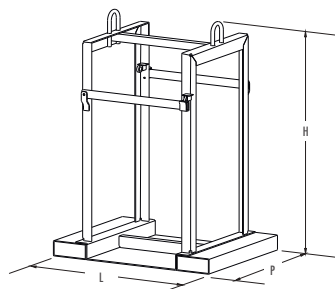

• Zincato a caldo
Hot-dip galvanized

• Con ganci di sollevamento
With lifting hooks and

• Con sedi forche
With fork seats

QUOTE SEDI FORCHE INTERNE | INTERNAL FORK SEATS DIMENSIONS

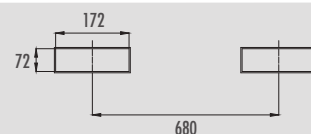

ACCESSORI | ACCESSORIES



99C444
RICAMBIO PER CINGHIA DI TRATTENUTA CARICO PER PALLET PORTA BOMBOLE
REPLACEMENT FOR LOAD HOLDING STRAP FOR PALLET FOR GAS CYLINDERS



CE
CRICCHETTO CON GANCIO A DOPPIO UNCINO PER CINGHIA PROFESSIONALE
PROFESSIONAL RATCHET STRAP DOUBLE HOOK



CE
CATENA 4 RAMI
4 LEGS CHAIN

MODELLO MODEL	CATENA CHAIN Ø	LUNGHEZZA LENGHT m	PORTATA LOAD CAPACITY kg
594B3	8	3	4250
594B4	8	4	4250

// PINZA A MANIGLIONE PER POSA CORDOLI
LARGE HANDLE FOR KERB LAYING

MODELLO MODEL	APERTURA OPENING mm	TARA TARE kg	PORTATA CAPACITY MAX kg	PESO PIENO CARICO TOTAL FULL LOAD WEIGHT kg
501	70-200	14	150	164
503	70-200	18	500	518



• Posa cordolo
Kerb laying



// PINZA A MANUBRIO PER POSA CORDOLI E CANALI
KERB GRIPPER FOR KERB AND CURBSTONE LAYING

MODELLO MODEL	APERTURA OPENING mm	TARA TARE kg	PORTATA CAPACITY MAX kg	PESO PIENO CARICO TOTAL FULL LOAD WEIGHT kg
508	510-1010	13	180	193



• Posa cordoli e canali
Kerb and curbstone
laying



// PINZA A GANCIO
RING GRAB

MODELLO MODEL	APERTURA OPENING mm	TARA TARE kg	PORTATA SINGOLA SINGLE CAPACITY kg	PORTATA COPPIA CHARGE IN PAIRS kg	PESO PIENO CARICO TOTAL FULL LOAD WEIGHT kg
515B	0-50	2	120	240	122
516B	0-90	7	600	1200	608
517B	90-150	13	1200	2400	1213
518B	140-220	17	2000	4000	2017



• Per pozzetti
For concrete shafts



// NEW JERSEY - AUTOMATICA
NEW JERSEY - AUTOMATIC

MODELLO MODEL	APERTURA OPENING mm	LUNGHEZZA DI PRESA GRIP LENGHT mm	TARA TARE kg	PORTATA CAPACITY MAX kg	PESO PIENO CARICO TOTAL FULL LOAD WEIGHT kg
528NJ5	0-850	720	245	5000	5245
528NJ6	0-850	720	261	6000	6261



// ACCESSORI | ACCESSORIES



//////
CATENA 2 RAMI
2 LEGS CHAIN



MODELLO MODEL	CATENA CHAIN Ø	LUNGHEZZA LENGHT m	PORTATA LOAD CAPACITY kg
592B2	8	2	2800
592B2	8	4	2800



//////
CATENA 3 RAMI
3 LEGS CHAIN



MODELLO MODEL	CATENA CHAIN Ø	LUNGHEZZA LENGHT m	PORTATA LOAD CAPACITY kg
593B25	8	2,5	4250
593B4	8	4	4250

////// MINI MAX - SEMIAUTOMATICA
MINI MAX - SEMIAUTOMATIC

MODELLO MODEL	APERTURA OPENING mm	ALTEZZA DI PRESA GRIP HEIGHT mm	LUNGHEZZA DI PRESA GRIP LENGHT mm	TARA TARE kg	PORTATA LOAD CAPACITY kg	PESO PIENO CARICO TOTAL FULL LOAD WEIGHT kg
525	50-260 260-510 510-750	300	150-290	30	1000	1030

CE



////// MINI MAX - AUTOMATICA
MINI MAX - AUTOMATIC

MODELLO MODEL	APERTURA OPENING mm	ALTEZZA DI PRESA GRIP HEIGHT mm	LUNGHEZZA DI PRESA GRIP LENGHT mm	TARA TARE kg	PORTATA LOAD CAPACITY kg	PESO PIENO CARICO TOTAL FULL LOAD WEIGHT kg
526	50-600	185	350	31	600	631

CE



////// BIG MAX - AUTOMATICA
BIG MAX - AUTOMATIC

MODELLO MODEL	APERTURA OPENING mm	TARA TARE kg	PORTATA CAPACITY MAX kg	PESO PIENO CARICO TOTAL FULL LOAD WEIGHT kg
526K25	200-1200	135	2500	2635

CE



• Per manufatti in cemento
For concrete products

////// FORCA A "C" - NON AUTOBILANCIATA (SENZA MOLLA)
"C" FORK - NOT SELF BALANCED (WITHOUT SPRING)

MODELLO MODEL	LUNGHEZZA MAX TUBO MAX PIPE LENGHT mm	TARA TARE kg	PORTATA CAPACITY MAX kg	PESO PIENO CARICO TOTAL FULL LOAD WEIGHT kg
541	2000	92	1000	1092
543	2000	122	2000	2122

CE



• Per tubi in cemento
For concrete pipes

////// FORCA A "C" - AUTOBILANCIATA
"C" FORK - SELF BALANCED

MODELLO MODEL	LUNGHEZZA MAX TUBO MAX PIPE LENGHT mm	TARA TARE kg	PORTATA CAPACITY MAX kg	PESO PIENO CARICO TOTAL FULL LOAD WEIGHT kg
543MR	2500	202	2000	2202
547MR	2500	381	4000	4381
551MR	2500	513	6000	6513

CE



// SOTTO GANCI CON GANCI SELF LOCKING
ONE LEG SLINGS WITH SELF LOCKING HOOKS

MODELLO MODEL	CATENA CHAIN Ø	LUNGHEZZA LENGTH m	TARA TARE kg	PORTATA LOAD CAPACITY kg
591D1	10	1	4,8	3150
591F1	13	1	7,3	5300



• GRADO 80
GRADE 80



• Targhetta identificativa
Identification plate



• Gancio Self Locking
Self Locking hook

// IMBRAGHI A CATENA CON GANCI SELF LOCKING, REGOLABILI CON GANCI ACCORCIATORI
HARNESS CHAINS WITH SELF LOCKING HOOKS, ADJUSTABLE THROUGH SHORTENING HOOKS

MODELLO MODEL	RAMI LEGS nr	CATENA CHAIN Ø	LUNGHEZZA LENGTH m	TARA TARE kg	PORTATA LOAD CAPACITY kg
592B2	2	8	2	9,2	2800
592B25	2	8	2,5	10	2800
592B3	2	8	3	11	2800
592B4	2	8	4	15,2	2800
592B6	2	8	6	20	2800



MODELLO MODEL	RAMI LEGS nr	CATENA CHAIN Ø	LUNGHEZZA LENGTH m	TARA TARE kg	PORTATA LOAD CAPACITY kg
593B2	3	8	2	14,9	4250
593B25	3	8	2,5	17,8	4250
593B4	3	8	4	24,3	4250



MODELLO MODEL	RAMI LEGS nr	CATENA CHAIN Ø	LUNGHEZZA LENGTH m	TARA TARE kg	PORTATA LOAD CAPACITY kg
594B2	4	8	2	19,2	4250
594B3	4	8	3	25	4250
594B4	4	8	4	32	4250



// IMBRAGHI A CATENA PER CESTONI SOLLEVABILI SENZA GANCI ACCORCIATORI
HARNESS CHAINS FOR LIFTING MAN BASKET WITHOUT SHORTENING HOOKS

MODELLO MODEL	RAMI LEGS nr	CATENA CHAIN Ø	LUNGHEZZA LENGTH m	PORTATA LOAD CAPACITY kg
594D3	4	10	3	6700
594D4	4	10	4	6700
594G3	4	13	3	11200
594G4	4	13	4	11200



// IMBRAGHI A CATENA PER BENNE ELICOTTERO SENZA GANCI ACCORCIATORI
HARNESS CHAINS FOR HELICOPTER BUCKET WITHOUT SHORTENING HOOKS

MODELLO MODEL	RAMI LEGS nr	CATENA CHAIN Ø	LUNGHEZZA LENGTH m	PORTATA LOAD CAPACITY kg
593A08	3	6	0,8	3000



• GRADO 100
GRADE 100

Gli imbraghi a catena sono accessori di sollevamento che vengono interposti tra l'organo mobile di carico (gancio) dell'apparecchio di sollevamento e la massa da movimentare allo scopo di consentirne la presa, il sollevamento e lo spostamento nello spazio. Gli imbraghi a catena, tramite l'azione dell'apparecchio di sollevamento (gru o paranco) su cui sono installate, possono sollevare la massa da movimentare verticalmente e liberamente nello spazio (senza guide). Gli imbraghi a catena sono progettati e prodotti in considerazione ed in modo da soddisfare tutte le esigenze imposte dai "Requisiti Essenziali di Sicurezza" della Direttiva Comunitaria 2006/42/CE, denominata Direttiva Macchine.

Il D.Lgs n.17 del 27 gennaio 2010 integra la direttiva 2006/42/CE ed indica che gli accessori di sollevamento, le catene, le funi e le cinghie, sono dispositivi amovibili di trasmissione meccanica e quindi rientrano nel "Campo di applicabilità" della Direttiva medesima.

Le funi e le catene debbono inoltre essere sottoposte a controlli trimestrali, anche in mancanza di specifica indicazione da parte del fabbricante, ai sensi del D.Lgs. 81/08, all. 6, punto 3.1.2. Informazioni, marcature e controlli sono quindi prescrizioni di legge imprescindibili anche per gli accessori sottogancio.

The harness chains are lifting accessories that are interposed between the mobile load device (hook) of the lifting appliance and the mass to be moved in order to allow it to be gripped, lifted and moved in space. The chain slings, through the action of the lifting device (crane or hoist) on which they are installed, can lift the mass to be moved vertically and freely in space (without guides).

The chain harnesses are designed and produced in consideration and in order to meet all the requirements imposed by the "Essential Safety Requirements" of the Community Directive 2006/42/EC, called Machinery Directive.

Legislative Decree no. 17 of 27 January 2010 of integrates Directive 2006/42/EC and indicates that lifting accessories, chains, ropes and straps are removable mechanical transmission devices and therefore are part of the "Field of applicability" of the Directive. The ropes and chains must also be subjected to quarterly checks, even in the absence of specific indication by the manufacturer, pursuant to Legislative Decree 81/08, Annex. 6, point 3.1.2. Therefore, information, markings and controls are mandatory prescriptions for under-hook accessories.



BRACHE IN POLIESTERE
POLYESTER FLAT WEBBING SLINGS



• COEFFICIENTE DI
SICUREZZA 7:1
SAFETY FACTOR 7:1

MODELLO MODEL	LUNGHEZZA LENGTH m	H NASTRO RIBBON mm	PORTATA LOAD CAPACITY kg
597A1	1	50	1000
597A2	2	50	1000
597A3	3	50	1000
597A4	4	50	1000
597A5	5	50	1000
597A6	6	50	1000
597A7	7	50	1000
597A8	8	50	1000

MODELLO MODEL	LUNGHEZZA LENGTH m	H NASTRO RIBBON mm	PORTATA LOAD CAPACITY kg
597B1	1	60	2000
597B2	2	60	2000
597B3	3	60	2000
597B4	4	60	2000
597B5	5	60	2000
597B6	6	60	2000
597B7	7	60	2000
597B8	8	60	2000

MODELLO MODEL	LUNGHEZZA LENGTH m	H NASTRO RIBBON mm	PORTATA LOAD CAPACITY kg
597C1	1	90	3000
597C2	2	90	3000
597C3	3	90	3000
597C4	4	90	3000
597C5	5	90	3000
597C6	6	90	3000
597C7	7	90	3000
597C8	8	90	3000

MODELLO MODEL	LUNGHEZZA LENGTH m	H NASTRO RIBBON mm	PORTATA LOAD CAPACITY kg
597D1	1	120	4000
597D2	2	120	4000
597D3	3	120	4000
597D4	4	120	4000
597D5	5	120	4000
597D6	6	120	4000
597D7	7	120	4000
597D8	8	120	4000



CONSIGLI PER L'UTILIZZO IN SICUREZZA
SAFETY ADVICE



Controllare il peso del carico
Check the weight of the load

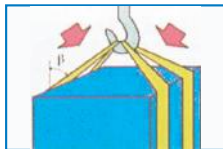

Tener conto del modo di imbragaggio
e dell'angolo di inclinazione
Consider the type of use and the
rake angle

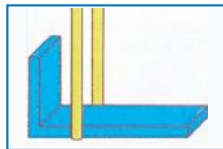

Tenere in considerazione il centro
di gravità del carico
Consider the gravity of inclination
center of the load

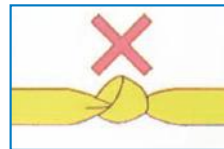

Non torcere o annodare
Don't twist or knot

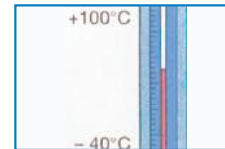

Utilizzare a temperature
comprese tra -40°C e +100°C
Temperature range of use
-40°C to +100°C

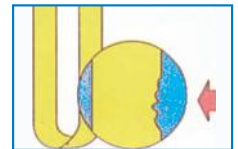

Controllare l'integrità delle fasce
prima di ogni utilizzo
Before any use check that the
slings are not damaged

LIMITAZIONI DELLA PORTATA DI UNA SINGOLA FASCIA DOVUTE A DIVERSI TIPI DI IMPIEGHI
WORKING LOAD LIMIT WITH 1 WEBBING SLING

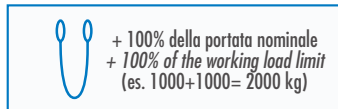

I cestoni sollevabili con gru sono progettati e prodotti in considerazione ed in modo da soddisfare tutte le esigenze imposte dai "Requisiti Essenziali di Sicurezza". Sono conformi ai requisiti imposti da:

- NORMA UNI EN 14502-1:2010: APPARECCHI DI SOLLEVAMENTO - ATTREZZATURE PER IL SOLLEVAMENTO DI PERSONE
 - D.Lgs 09/04/2008 NR. 81, allegato VI punto 3.1.4
 - Il D.Lgs. n. 81/2008 proibisce, come regola generale, l'uso di una macchina per una funzione per la quale non è stata progettata. Tale uso è, però, ammesso "a titolo eccezionale" nei casi previsti a condizione che vengano prese adeguate misure di sicurezza conformemente a disposizioni di buona tecnica. Al riguardo, il Ministero del Lavoro e delle Politiche Sociali, considerato che la disposizione in esame è stata introdotta per garantire in concreto valide condizioni di sicurezza ai lavoratori nelle operazioni di sollevamento svolte con attrezzature non previste a tal fine, ritiene che la stessa possa trovare applicazione nei seguenti casi:
 - quando si tratti di operare in situazioni di emergenza;
 - per attività la cui esecuzione immediata è necessaria per prevenire situazioni di pericolo, incidenti imminenti o per organizzare misure di salvataggio;
 - quando per l'effettuazione di determinate operazioni rese necessarie dalla specificità del sito o del contesto lavorativo le attrezzature disponibili o ragionevolmente reperibili sul mercato non garantiscono maggiori condizioni di sicurezza.
- Le seguenti operazioni di sollevamento persone con attrezzature non specificamente previste, unicamente nei casi indicati, vanno effettuate secondo specifiche procedure di sicurezza che comprendano a valle una analisi dei rischi, i criteri per la scelta più appropriata delle attrezzature da impiegare, i requisiti delle apparecchiature accessorie da abbinare ad essi, le modalità operative per le varie fasi di lavoro in cui i sistemi così realizzati sono utilizzati nonché quelle per la sorveglianza ed il controllo delle une e delle altre.



The lifting man basket are designed and produced taking satisfying all the requirements imposed by the "Essential Safety Requirements".

- Complies with the requirements imposed from:
- STANDARD UNI EN 14502-1:2010: LIFTING EQUIPMENT - EQUIPMENT FOR LIFTING PEOPLE
 - Leg. Dec. 09/04/2008 NR. 81, attachment VI, point 3.1.4
- Legislative Decree no. 81/2008 prohibits, as a general rule, the use of a machine for a function for which it has not been designed. Such use is, however, admitted "in exceptional cases" provided that appropriate security measures are taken in accordance with good technical provisions. In this regard, the Ministry of Labor and Social Policies, given that this provision was introduced in order to guarantee valid safety conditions for workers in lifting operations carried out with equipment not provided for this purpose, the Ministry of Labor and Social Policies believes that it can be applied in the following cases:
- when dealing with emergency situations;
 - for activities whose immediate execution is necessary to prevent dangerous situations, imminent incidents or to arrange rescue measures;
 - whenever the performance of any operations required by the specifics of the site or of the workplace context, the equipment available or reasonably available on the market does not guarantee greater security conditions. Lifting people with equipment not specifically provided, only in the cases indicated, should be carried out in accordance with specific safety procedures which include a risk analysis, criteria for the most appropriate choice of equipment to be used, requirements for ancillary equipment to combine with, the operating modes for the various work phases in which the systems thus realized are used as well as those for the surveillance and control of one another and of the others.

/// CESTONE SOLLEVABILE PER 1 PERSONA, ZINCATO
LIFTING MAN BASKET FOR 1 PERSON, ZINC COATED

MODELLO MODEL	DIMENSIONI DIMENSIONS mm			N° PERSONE A BORDO No. OF PEOPLE ON BOARD	TARA TARE kg	PESO PIENO CARICO TOTAL FULL LOAD WEIGHT kg	PORTATA LOAD CAPACITY kg
	H1	H2	Ø				
367AR	2400	1150	660	1	80	230	150

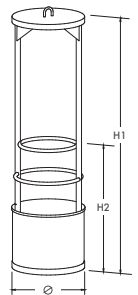

/// CESTONE SOLLEVABILE PER 2 PERSONE, ZINCATO
LIFTING MAN BASKET FOR 2 PEOPLE, ZINC COATED

MODELLO MODEL	DIMENSIONI DIMENSIONS mm			N° PERSONE A BORDO No. OF PEOPLE ON BOARD	TARA TARE kg	PESO PIENO CARICO TOTAL FULL LOAD WEIGHT kg	PORTATA LOAD CAPACITY kg
	H1	H2	Ø				
367BR	2400	1150	950	2	138	438	300

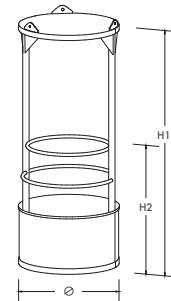

/// CESTONE SOLLEVABILE PER 4 PERSONE
LIFTING MAN BASKET FOR 4 PEOPLE

MODELLO MODEL	DIMENSIONI DIMENSIONS mm				N° PERSONE A BORDO No. OF PEOPLE ON BOARD	TARA TARE kg	PESO PIENO CARICO TOTAL FULL LOAD WEIGHT kg	PORTATA LOAD CAPACITY kg
	L	P	H1	H2				
367	1400	1000	2400	1280	4	312	812	500

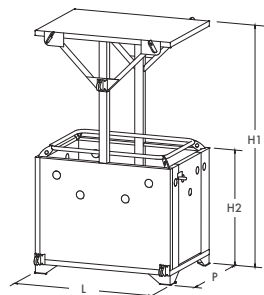

/// ACCESSORI | ACCESSORIES



99C201
KIT
IMBRAGATURA
DA LAVORO
HARNES KIT



99C376
CASCHETTO
DI SICUREZZA
SECURITY
HELMET



SOTTO GANCIO
PER 367AR
ONE LEG SLING
FOR 367AR



MODELLO MODEL	CATENA CHAIN Ø	LUNGHEZZA LENGHT m	PORTATA LOAD CAPACITY kg
591D1	10	1	3150
591F1	13	1	5300



CATENA 3 RAMI
PER 367BR
3 LEGS CHAIN
FOR 367BR



MODELLO MODEL	CATENA CHAIN Ø	LUNGHEZZA LENGHT m	PORTATA LOAD CAPACITY kg
593B25	8	2,5	4250
593B4	8	4	4250

////// CESTONE SOLLEVABILE CON TETTO SFILABILE PER 4 PERSONE
LIFTING MAN BASKET WITH REMOVABLE ROOF FOR 4 PEOPLE

MODELLO MODEL	DIMENSIONI DIMENSIONS mm				N° PERSONE A BORDO No. OF PEOPLE ON BOARD	TARA TARE kg	PESO PIENO CARICO TOTAL FULL LOAD WEIGHT kg	PORTATA LOAD CAPACITY kg
	L	P	H1	H2				
367TS	1400	1000	2400	1280	4	345	845	500

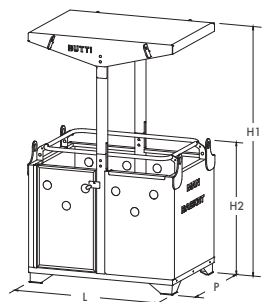

////// CESTONE SOLLEVABILE STANDARD PER 5 PERSONE
LIFTING MAN BASKET FOR 5 PEOPLE

MODELLO MODEL	DIMENSIONI DIMENSIONS mm				N° PERSONE A BORDO No. OF PEOPLE ON BOARD	TARA TARE kg	PESO PIENO CARICO TOTAL FULL LOAD WEIGHT kg	PORTATA LOAD CAPACITY kg
	L	P	H1	H2				
367L	2500	1400	2400	1280	5	555	1155	600

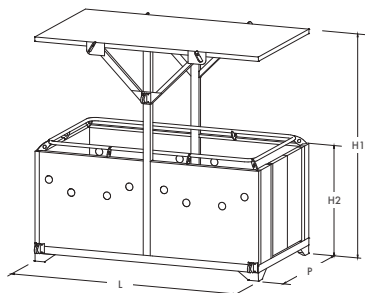

////// CESTONE SOLLEVABILE PER PRONTO INTERVENTO
FIRST AID LIFTING MAN BASKET



MODELLO MODEL	DIMENSIONI DIMENSIONS mm				N° PERSONE A BORDO No. OF PEOPLE ON BOARD	TARA TARE kg	PESO PIENO CARICO TOTAL FULL LOAD WEIGHT kg	PORTATA LOAD CAPACITY kg
	L	P	H1	H2				
367F	2500	1400	2400	1280	4+1	555	1155	600

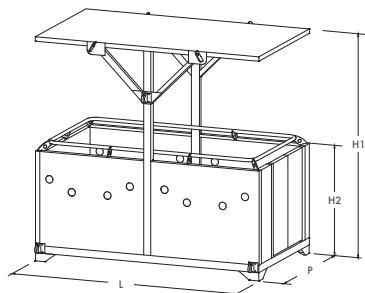

ACCESSORI | ACCESSORIES //



//////
CATENA 4 RAMI
PER 367, 367TS
4 LEGS CHAIN
FOR 367, 367TS



MODELLO MODEL	CATENA CHAIN Ø	LUNGHEZZA LENGHT m	PORTATA LOAD CAPACITY kg
594D3	10	3	6700
594D4	10	4	6700



//////
CATENA 4 RAMI
PER 367L, 367F
4 LEGS CHAIN
FOR 367L, 367F



MODELLO MODEL	CATENA CHAIN Ø	LUNGHEZZA LENGHT m	PORTATA LOAD CAPACITY kg
594G3	13	3	11200
594G4	13	4	11200



//////
99C334
BARELLA TOBOGA CON
CINTURE E POGGIPIEDI
PER 367F
TOBOGA STRETCHER WITH
SAFETY BELT AND FOOTREST
FOR 367F

CONTENITORE PER MANUTENZIONE AEREA PER 1 PERSONA
BASKET FOR AERIAL MAINTENANCE FOR 1 PERSON

MODELLO MODEL	DIMENSIONI DIMENSIONS mm				PORTATA LOAD CAPACITY kg
	L	P	H	H1	
975	1000	1000	2000	1200	300



QUOTE SEDI FORCHE INTERNE | INTERNAL FORK SEATS DIMENSIONS

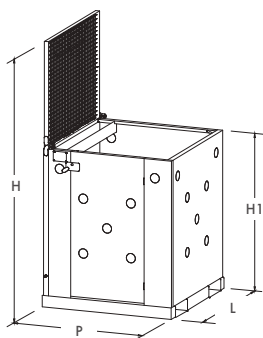
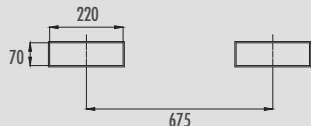

CONTENITORE PER MANUTENZIONE AEREA PER 2 PERSONE
BASKET FOR AERIAL MAINTENANCE FOR 2 PEOPLE

MODELLO MODEL	DIMENSIONI DIMENSIONS mm				PORTATA LOAD CAPACITY kg
	L	P	H	H1	
975P2	1500	1000	2000	1200	300



QUOTE SEDI FORCHE INTERNE | INTERNAL FORK SEATS DIMENSIONS

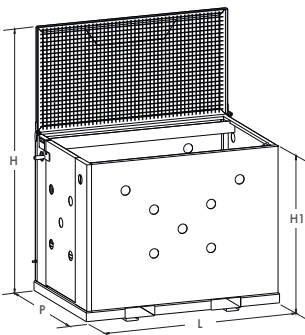
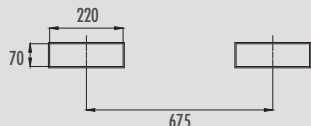

La sicurezza del lavoratore nelle operazioni di sollevamento in quota è assicurata grazie ai contenitori per manutenzione aerea. Conformi a tutte le normative vigenti, assicurano la stabilità necessaria a lasciare libero il lavoratore nei movimenti ed eliminando i rischi di caduta. Il contenitore per manutenzione aerea è corredato di manuale d'uso e relative istruzioni di utilizzo in osservanza a quanto richiesto dal D.Lgs. 9 aprile 2008 n. 81, punto 3.1.4 allegato VI.

Worker's safety during lifting operations is guaranteed by using the baskets for aerial maintenance. They comply with all current regulations and ensure the necessary balance the worker needs to be free to move without any risk of fall. The basket for aerial maintenance is accompanied by user manual and related instructions for use in compliance with the provisions of Legislative Decree 9 April 2008, no. 81, point 3.1.4 annex VI.



ACCESSORI | ACCESSORIES

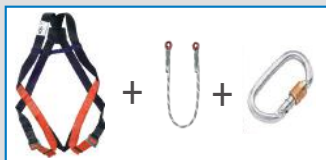

99C201
KIT IMBRAGATURA DA LAVORO:
IMBRAGATURA PER IL CORPO + CORDINO DI TRATTENIMENTO
+ MOSCHETTONE
HARNESS KIT:
BODY HARNESS + RETENTION ROPE + CARABINER



99C376
CASCHETTO ALTA SICUREZZA
SECURITY HELMET
HIGH SAFETY



RUOTE CON FRENO Ø
125 mm GIREVOLI
SWIVEL WHEELS Ø 125
mm WITH BRAKE

////// CONICHE A SCARICO CENTRALE
CONICAL WITH CENTRAL UNLOADING

MODELLO MODEL	DIMENSIONI DIMENSIONS mm				TARA TARE kg	CAPACITÀ CAPACITY l	PORTATA LOAD CAPACITY kg	PESO PIENO CARICO TOTAL FULL LOAD WEIGHT kg
	D1	D2	H1	H2				
199	725	535	710	580	34	100	220	254
200	725	535	835	700	38	150	330	368

MODELLO MODEL	DIMENSIONI DIMENSIONS mm				TARA TARE kg	CAPACITÀ CAPACITY l	PORTATA LOAD CAPACITY kg	PESO PIENO CARICO TOTAL FULL LOAD WEIGHT kg
	D1	D2	H1	H2				
205	1150	720	1180	1050	90	500	1100	1190
206	1150	720	1260	1125	95	600	1320	1415

MODELLO MODEL	DIMENSIONI DIMENSIONS mm				TARA TARE kg	CAPACITÀ CAPACITY l	PORTATA LOAD CAPACITY kg	PESO PIENO CARICO TOTAL FULL LOAD WEIGHT kg
	D1	D2	H1	H2				
207	1150	720	1485	1305	128	800	1760	1888
208	1150	720	1660	1480	140	1000	2200	2340

MODELLO MODEL	DIMENSIONI DIMENSIONS mm				TARA TARE kg	CAPACITÀ CAPACITY l	PORTATA LOAD CAPACITY kg	PESO PIENO CARICO TOTAL FULL LOAD WEIGHT kg
	D1	D2	H1	H2				
209	1675	980	1600	1400	300	1500	3300	3600
210	1675	980	1850	1650	330	2000	4400	4730
210V	1675	980	1850	1650	380	2000 vol	4400	4780
210B	1675	1100	2375	2150	430	3000	6600	7030

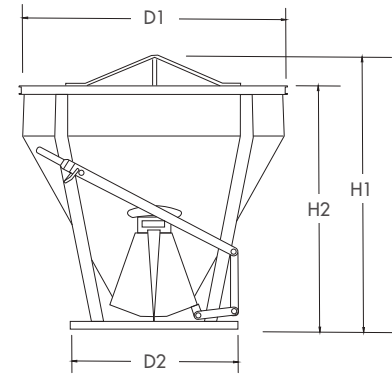

////// CE

MODELLO MODEL	CATENA CHAIN Ø	LUNGHEZZA LENGHT m	PORTATA LOAD CAPACITY kg
591D1	10	1	3150
591F1	13	1	5300

CLI CONICHE A SCARICO CENTRALE E LATERALE
CLI CONICAL BUCKETS WITH CENTRAL & SIDE UNLOADING



MODELLO MODEL	DIMENSIONI DIMENSIONS mm				TARA TARE kg	CAPACITÀ CAPACITY l	PORTATA LOAD CAPACITY kg	PESO PIENO CARICO TOTAL FULL LOAD WEIGHT kg
	D1	D2	H1	H2				
212	900	720	930	780	74	250	550	624
213	900	720	1010	850	78	300	660	738
213Z	900	720	1095	940	85	350	770	855

MODELLO MODEL	DIMENSIONI DIMENSIONS mm				TARA TARE kg	CAPACITÀ CAPACITY l	PORTATA LOAD CAPACITY kg	PESO PIENO CARICO TOTAL FULL LOAD WEIGHT kg
	D1	D2	H1	H2				
214	1150	720	1090	955	100	400	880	980
215	1150	720	1180	1050	107	500	1100	1207
216	1150	720	1260	1125	112	600	1320	1432

MODELLO MODEL	DIMENSIONI DIMENSIONS mm				TARA TARE kg	CAPACITÀ CAPACITY l	PORTATA LOAD CAPACITY kg	PESO PIENO CARICO TOTAL FULL LOAD WEIGHT kg
	D1	D2	H1	H2				
217	1150	720	1475	1035	152	800	1760	1912
218	1150	720	1650	1480	162	1000	2200	2362

MODELLO MODEL	DIMENSIONI DIMENSIONS mm				TARA TARE kg	CAPACITÀ CAPACITY l	PORTATA LOAD CAPACITY kg	PESO PIENO CARICO TOTAL FULL LOAD WEIGHT kg
	D1	D2	H1	H2				
218U	1350	980	1550	1380	234	1000	2200	2434
219U	1675	980	1600	1400	325	1500	3300	3625
219X20U	1675	980	1850	1650	352	2000	4400	4752

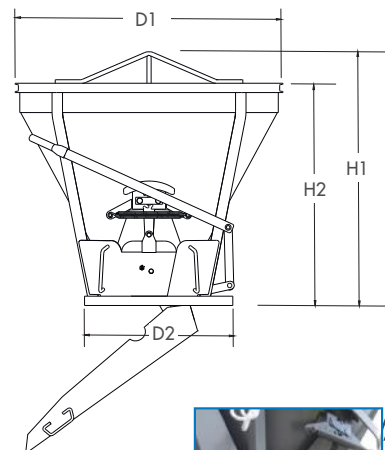

• Pratiche maniglie di presa
Practical gripping handles



• Coperchio con chiusura
automatica
Lid with automatic
closing



• Scivolo con apertura e
chiusura servo assistita
Slide with servo-
assisted opening and
closing

ACCESSORI | ACCESSORIES



MODELLO MODEL	CATENA CHAIN Ø	LUNGHEZZA LENGHT m	PORTATA LOAD CAPACITY kg
591D1	10	1	3150
591F1	13	1	5300

////// SUPER RIBASSATE A SCARICO CENTRALE
SUPER LOWERED CONICAL WITH CENTRAL UNLOADING

MODELLO MODEL	DIMENSIONI DIMENSIONS mm				TARA TARE kg	CAPACITÀ CAPACITY l	PORTATA LOAD CAPACITY kg	PESO PIENO CARICO TOTAL FULL LOAD WEIGHT kg
	D1	D2	H1	H2				
201S	1130	720	700	580	58	200	440	498
202S	1100	720	750	620	63	250	550	613
203S	1100	720	800	670	69	300	660	729

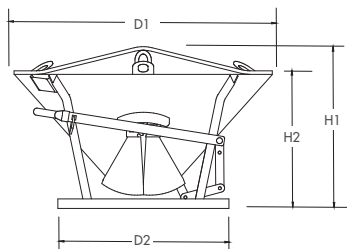

• Uso con betoniera senza bisogno di fare buche
Use with concrete mixer without having to make holes

////// SUPER RIBASSATE A SCARICO CENTRALE CON SEDI FORCHE
SUPER LOWERED CONICAL WITH CENTRAL UNLOADING AND FORK SEATS

MODELLO MODEL	DIMENSIONI DIMENSIONS mm				TARA TARE kg	CAPACITÀ CAPACITY l	PORTATA LOAD CAPACITY kg	PESO PIENO CARICO TOTAL FULL LOAD WEIGHT kg
	D1	D2	H1	H2				
201SF	1130	720	700	580	69	200	440	509
202SF	1100	720	750	620	74	250	550	624
203SF	1100	720	800	670	80	300	660	740

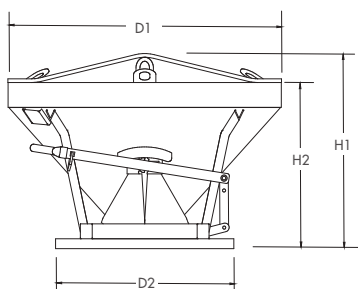

• Inforcamento Forking

////// QUOTE SEDI FORCHE INTERNE | INTERNAL FORK SEATS DIMENSIONS

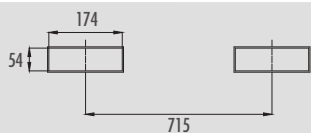

////// PORTA MALTA
MORTAR HOLDER

MODELLO MODEL	DIMENSIONI DIMENSIONS mm			TARA TARE kg	CAPACITÀ CAPACITY l	PORTATA LOAD CAPACITY kg	PESO PIENO CARICO TOTAL FULL LOAD WEIGHT kg
	L	P	H				
141	1480	910	330	48	300	660	708
142	1480	910	430	54	400	880	934
143	1530	950	540	69	500	1100	1169

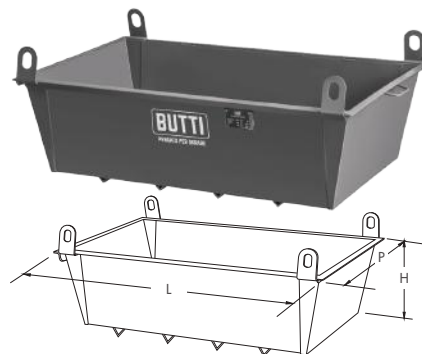

////// PORTA MALTA CON SEDI FORCHE
MORTAR HOLDER WITH FORK SEATS

MODELLO MODEL	DIMENSIONI DIMENSIONS mm			TARA TARE kg	CAPACITÀ CAPACITY l	PORTATA LOAD CAPACITY kg	PESO PIENO CARICO TOTAL FULL LOAD WEIGHT kg
	L	P	H				
141SF	1480	910	390	67	300	660	727
142SF	1480	910	490	73	400	880	953
143SF	1530	950	600	88	500	1100	1188

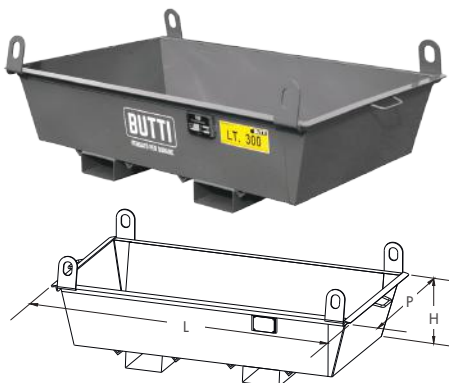

////// QUOTE SEDI FORCHE INTERNE | INTERNAL FORK SEATS DIMENSIONS

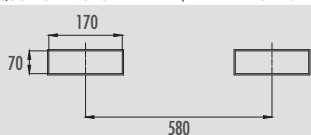

ACCESSORI | ACCESSORIES

////// CE			
MODELLO MODEL	CATENA CHAIN Ø	LUNGHEZZA LENGHT m	PORTATA LOAD CAPACITY kg
591D1	10	1	3150
591F1	13	1	5300

EUROPA CONICHE CON TUBO DI SCARICO
EUROPA CONICAL WITH RUBBER HOSE UNLOADING

MODELLO MODEL	DIMENSIONI DIMENSIONS mm					TARA TARE kg	CAPACITÀ CAPACITY l	PORTATA LOAD CAPACITY kg	PESO PIENO CARICO TOTAL FULL LOAD WEIGHT kg
	D1	D2	H1	H2	TUBO HOSE Ø				
303	1300	770	1250	1115	200	110	400	880	990
304	1300	770	1335	1205	200	125	500	1100	1225
305	1300	770	1430	1285	200	132	600	1320	1452

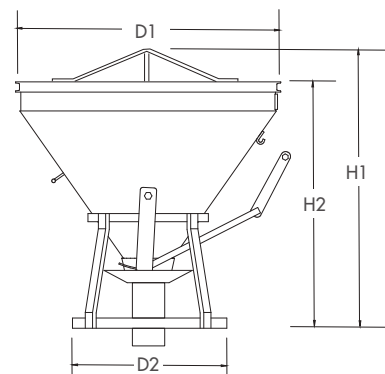

MODELLO MODEL	DIMENSIONI DIMENSIONS mm					TARA TARE kg	CAPACITÀ CAPACITY l	PORTATA LOAD CAPACITY kg	PESO PIENO CARICO TOTAL FULL LOAD WEIGHT kg
	D1	D2	H1	H2	TUBO HOSE Ø				
306	1300	780	1625	1450	200	160	800	1760	1920
307	1300	780	1775	1610	200	180	1000	2200	2380
308	1450	950	1930	1775	200	280	1500	3300	3580
309	1450	950	2225	2070	200	290	2000	4400	4690
309BX	1700	1100	2715	2490	250	440	3000	6600	7040



• Sistema di apertura bocca di scarico
Exhaust opening system

CULLA CON TUBO DI SCARICO
LAYDOWN BUCKET WITH RUBBER HOSE UNLOADING

MODELLO MODEL	DIMENSIONI DIMENSIONS mm				TARA TARE kg	CAPACITÀ CAPACITY l	PORTATA LOAD CAPACITY kg	PESO PIENO CARICO TOTAL FULL LOAD WEIGHT kg
	L	H	D	TUBO HOSE Ø				
307CSVU	2600	900	1305	200	330	1000	2200	2530
308CSVU	2910	1080	1490	200	450	1500	3300	3850
309CSVU	3210	1180	1490	200	510	2000	4400	4910
309BCSVU	3500	1280	1490	200	660	3000	6600	7260

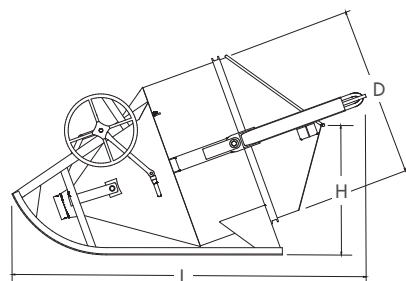

• Volantino di apertura e chiusura della bocca di scarico
Wheel to open and close the discharge opening

ACCESSORI | ACCESSORIES



MODELLO MODEL	CATENA CHAIN Ø	LUNGHEZZA LENGHT m	PORTATA LOAD CAPACITY kg
591D1	10	1	3150
591F1	13	1	5300

ELICOTTERO CON CATENA
HELICOPTER WITH CHAIN

MODELLO MODEL	DIMENSIONI DIMENSIONS mm				TARA TARE kg	CAPACITÀ CAPACITY l	PORTATA LOAD CAPACITY kg	PESO PIENO CARICO TOTAL FULL LOAD WEIGHT kg
	D1	D2	H1	H2				
203ZTEC	1000	900	1020	960	69	370	814	883
204ZTEC	1000	900	1160	1100	73	470	1034	1107

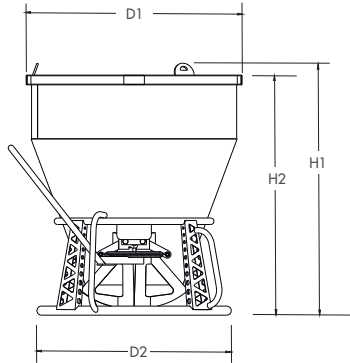

• MASSIMA
LEGGEREZZA
MAXIMUM
LIGHTNESS



• CATENA Ø 6 mm
ULTRA LEGGERA
CHAIN Ø 6 mm
ULTRA LIGHT



• Leva di bloccaggio in posizione aperta della bocca di scarico: la bocca di scarico aperta permette il passaggio dell'aria per una migliore aerodinamica in fase di volo, agevolando il trasporto
Lever for locking in open position to discharge: the open discharge mouth allows the passage of air for better aerodynamics during flight, facilitating transport

ELICOTTERO MANICO FISSO
HELICOPTER WITH FIXED HANDLE

MODELLO MODEL	DIMENSIONI DIMENSIONS mm				TARA TARE kg	CAPACITÀ CAPACITY l	PORTATA LOAD CAPACITY kg	PESO PIENO CARICO TOTAL FULL LOAD WEIGHT kg
	D1	D2	H1	H2				
203ZTEM	1000	900	1100	960	72	370	814	886
204ZTEM	1000	900	1240	1100	76	470	1034	1110

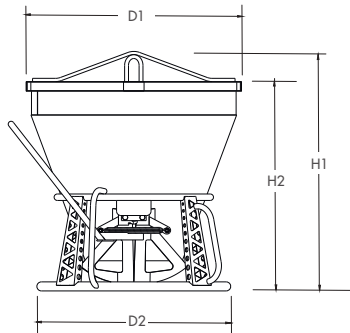

FASCIA AGGIUNTIVA IN ACCIAIO PER CARICO SABBIA
ADDITIONAL STEEL BAND FOR SAND LOAD

MODELLO MODEL	TARA TARE kg	CAPACITÀ CAPACITY l	PORTATA LOAD CAPACITY kg
99C344	13	180	297



• Applicabile ai modelli di benna elicottero con capacità 370 litri. La capacità totale della benna con la fascia è di 550 litri ed è utilizzabile solo con sabbia con peso specifico 1,65 kg/dm³
Suitable for helicopter bucket models with 370 liters capacity. The total capacity of the bucket with the steel band is 550 liters and can only be used with sand with a specific weight of 1.65 kg/dm³

ACCESSORI | ACCESSORIES



CATENA 3 RAMI
PER BENNE ELICOTTERO
3 LEGS CHAIN
FOR HELICOPTER BUCKET

MODELLO MODEL	CATENA CHAIN Ø	LUNGHEZZA LENGTH m	PORTATA LOAD CAPACITY kg
593A08	6	0,8	3000



AUTOSCARICANTE - AUTOMATICA
SELF DUMPING BIN - AUTOMATIC

MODELLO MODEL	DIMENSIONI DIMENSIONS mm				TARA TARE kg	CAPACITÀ CAPACITY l	PORTATA LOAD CAPACITY kg	PESO PIENO CARICO TOTAL FULL LOAD WEIGHT kg
	L	P	H1	H2				
231	710	620	760	360	23	100	165	188
234	1020	960	1120	505	65	300	495	560
235	1125	1090	1175	505	90	400	660	750
236	1225	1090	1225	575	98	500	825	923
236B	1225	1090	1300	680	110	600	990	1100
237	1525	1330	1500	650	174	800	1320	1494
238	1530	1330	1565	755	199	1000	1650	1849

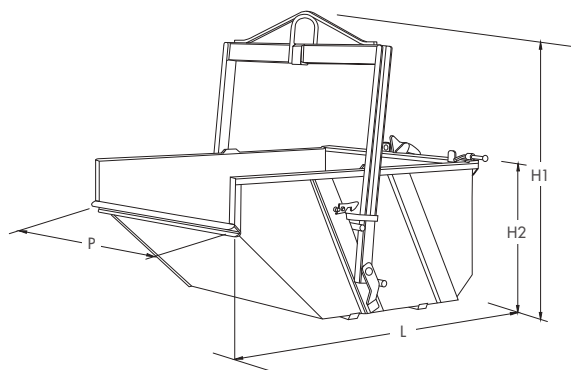

• Meccanismo di sicurezza antiribaltamento del manico per modelli da 100 a 1000 litri
Safety roll over handle hook for models from 100 to 1000 liters

MODELLO MODEL	DIMENSIONI DIMENSIONS mm				TARA TARE kg	CAPACITÀ CAPACITY l	PORTATA LOAD CAPACITY kg	PESO PIENO CARICO TOTAL FULL LOAD WEIGHT kg
	L	P	H1	H2				
239U	1855	1380	1390	840	278	1500	2475	2753
239AU	1990	1720	1540	840	410	2000	3300	3710
239BU	2230	2030	1720	960	660	3000	4950	5610
239CU	2290	2250	1870	1120	830	4000	6600	7430
239D	2650	2330	2255	1265	1300	5000	8250	9550
239G	3800	2170	2850	1600	2950	8000	13200	16150
239I	4020	2170	3170	1850	3850	10000	16500	20350

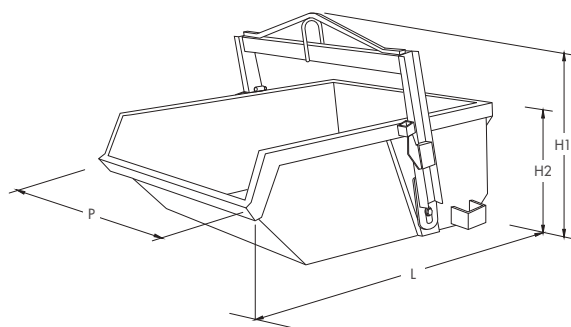

• Sistema di aggancio del manico per modelli da 1500 a 10000 litri
Handle attachment system for models from 1500 to 10000 liters

ACCESSORI | ACCESSORIES



MODELLO MODEL	CATENA CHAIN Ø	LUNGHEZZA LENGHT m	PORTATA LOAD CAPACITY kg
591D1	10	1	3150
591F1	13	1	5300

ELEVATORE
TIPPING BIN

MODELLO MODEL	DIMENSIONI DIMENSIONS mm				TARA TARE kg	CAPACITÀ CAPACITY l	PORTATA LOAD CAPACITY kg	PESO PIENO CARICO TOTAL FULL LOAD WEIGHT kg
	L	P	H1	H2				
240	640	520	620	360	17	60	132	149
241	710	600	700	400	20	100	220	240
242	750	705	830	440	27	150	330	357
244	930	1010	890	520	46	300	660	706

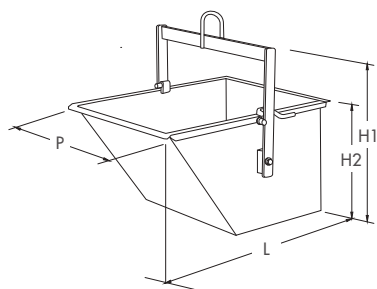

BENNA SABBIA CON RIBALTAMENTO AUTOMATICO
SAND BUCKET WITH AUTOMATIC ROLL OVER

MODELLO MODEL	DIMENSIONI DIMENSIONS mm				TARA TARE kg	PESO PIENO CARICO TOTAL FULL LOAD WEIGHT kg	PORTATA LOAD CAPACITY kg	VOLUME l
	L	P1	P2	H				
310	1200	1450	950	700	170	1070	900	500

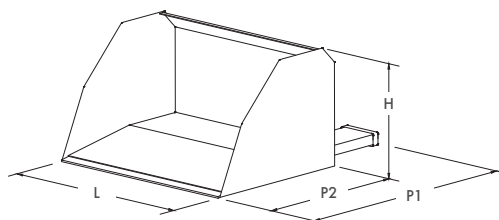

- A richiesta:
SISTEMA DI
RIBALTAMENTO
IDRAULICO
On demand:
HYDRAULIC TIPPING
SYSTEM

QUOTE SEDI FORCHE INTERNE | INTERNAL FORK SEATS DIMENSIONS

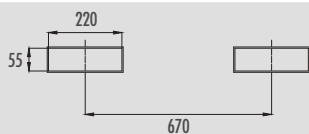

ACCESSORI | ACCESSORIES

MODELLO MODEL	CATENA CHAIN Ø	LUNGHEZZA LENGHT m	PORTATA LOAD CAPACITY kg
591F1	13	1	5300

QUADRA CON SEDI FORCHE
SQUARED WITH FORKLIFT SEATS

MODELLO MODEL	DIMENSIONI DIMENSIONS mm				TARA TARE kg	CAPACITÀ CAPACITY l	PORTATA LOAD CAPACITY kg	PESO PIENO CARICO TOTAL FULL LOAD WEIGHT kg
	L	P	H1	H2				
321	1180	1130	2020	1420	193	600	1320	1513
3211 idraulica hydraulic	1180	1130	2020	1420	201	600	1320	1521

QUOTE SEDI FORCHE INTERNE | INTERNAL FORK SEATS DIMENSIONS

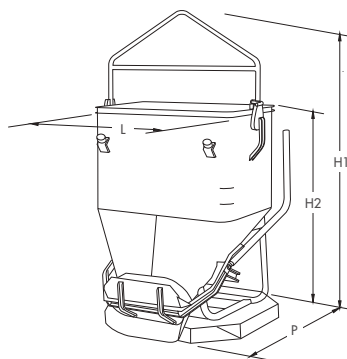
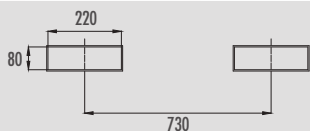

• Ampia bocca di scarico
Ampia bocca di scarico



• Sistema idraulico a richiesta
Hydraulic system on demand



• 4 inserimenti per carrello
4 seats forklift

MODELLO MODEL	DIMENSIONI DIMENSIONS mm				TARA TARE kg	CAPACITÀ CAPACITY l	PORTATA LOAD CAPACITY kg	PESO PIENO CARICO TOTAL FULL LOAD WEIGHT kg
	L	P	H1	H2				
322	1560	1285	2305	1440	340	800	1760	2100
323	1560	1285	2505	1640	360	1000	2200	2560

QUOTE SEDI FORCHE INTERNE | INTERNAL FORK SEATS DIMENSIONS

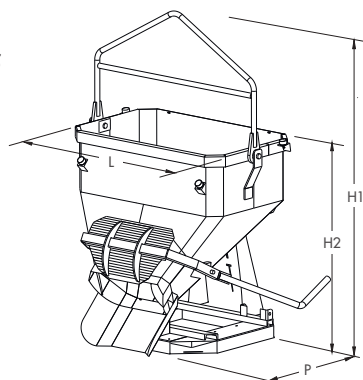
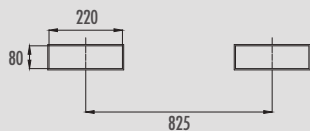

• Ampia bocca di scarico
Ampia bocca di scarico

BICICLETTA CON RUOTE ALTE
BARROW WITH HIGH WHEELS

MODELLO MODEL	DIMENSIONI DIMENSIONS mm								TARA TARE kg	CAPACITÀ CAPACITY l	PORTATA LOAD CAPACITY kg	PESO PIENO CARICO TOTAL FULL LOAD WEIGHT kg
	L1	L2	P1	P2	H1	H2	H3	H4				
271	1410	950	850	545	1320	1030	860	665	51	160	350	401

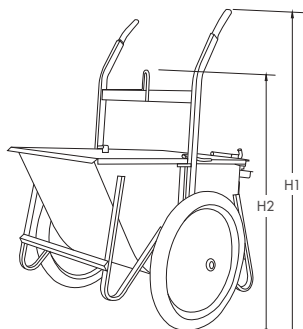
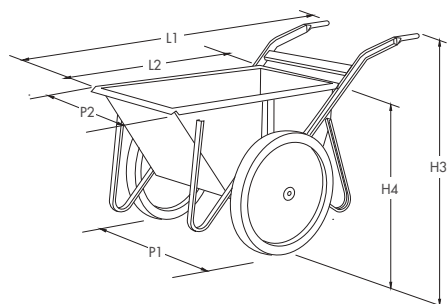

• Benna bicidetta sollevata
tramite gancio
Barrow bucket raised
by hook

////// MULTIBENNA MINI
MULTIBENNA MINI

MODELLO MODEL	DIMENSIONI DIMENSIONS mm						PORTATA LOAD CAPACITY kg	VOLUME lt
	P1	L1	L2	L3	H1	H2		
641MC2 MINI	1100	2300	1200	1250	1210	825	3300	2000

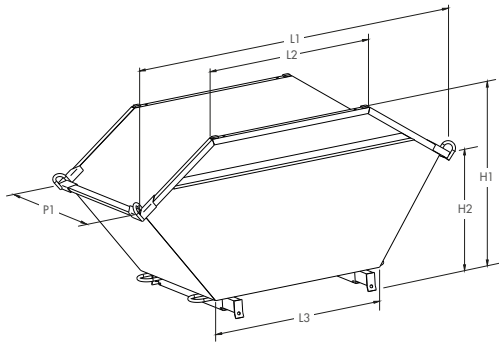

////// MULTIBENNA MAXI E SUPER MAXI
MULTIBENNA MAXI AND SUPER MAXI

MODELLO MODEL	DIMENSIONI DIMENSIONS mm						VOLUME m ³
	P1	P2	P3	L1	H1	H2	
640MC5 MAXI	2000	1800	750	3100	1300	800	5,5

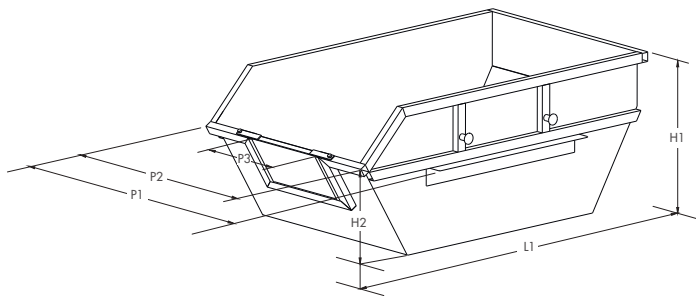

- LA MULTIBENNA 640MC5 PRESENTA UNA SPONDA FRONTALE AMOVIBILE PER IL CARICO CON CARRIOLA
THE 640MC5 MULTIBENNA HAS A REMOVABLE FRONT PANEL FOR LOADING WITH WHEELBARROW



MODELLO MODEL	DIMENSIONI DIMENSIONS mm					VOLUME m ³
	P1	P2	L1	H1	H2	
640MC7 MAXI	2000	1800	3600	1500	1000	7
640MC10 SUPER MAXI	2000	1830	3850	1800	1300	10

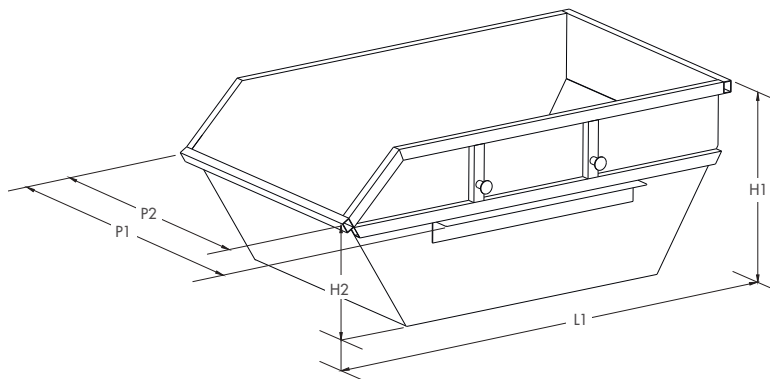

// 24H - VALIGETTA PORTA ATTREZZI
24H - TOOL CASE

MODELLO MODEL	DIMENSIONI DIMENSIONS mm			TARA TARE kg
	L	P	H	
343V48	480	290	180	4



// BAULI PORTA ATTREZZI
TOOLS CHESTS

MODELLO MODEL	DIMENSIONI DIMENSIONS mm			TARA TARE kg
	L	P	H	
344B65	650	360	300	9
344B75	750	410	350	11

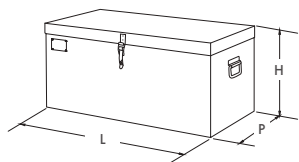

// PORTA UTENSILI
TOOLS HOLDER

MODELLO MODEL	DIMENSIONI DIMENSIONS mm			VOLUME lt	TARA TARE kg
	L	P	H		
345	850	500	435	170	27

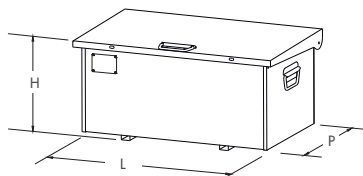

- Con coperchio zincato
With zinc coated lid
- Lucchetti CISA di serie
CISA padlock included



// PORTA ATTREZZI
TOOLS HOLDER

MODELLO MODEL	DIMENSIONI DIMENSIONS mm			TARA TARE kg	PESO PIENO CARICO TOTAL FULL LOAD WEIGHT kg	VOLUME lt	PORTATA LOAD CAPACITY kg
	L	P	H				
350	1000	500	750	50	350	350	300
350Z zincato zinc coated	1000	500	750	53	353	350	300

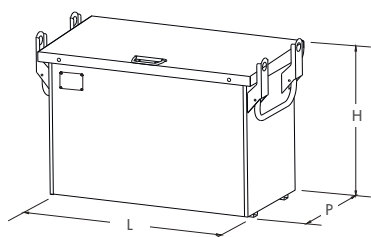

- Con coperchio zincato
With zinc coated lid
- Lucchetti CISA di serie
CISA padlock included



PORTA ATTREZZI
TOOLS HOLDER

MODELLO MODEL	DIMENSIONI DIMENSIONS mm			TARA TARE kg	PESO PIENO CARICO TOTAL FULL LOAD WEIGHT kg	VOLUME lt	PORTATA LOAD CAPACITY kg
	L	P	H				
351	1000	1000	790	77	577	700	500
351Z zincato zinc coated	1000	1000	790	83	589	700	500

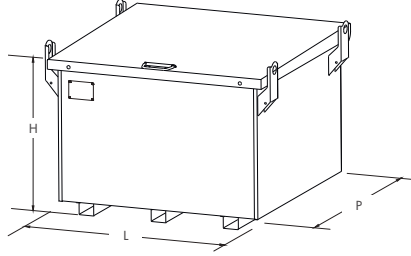

- Con coperchio zincato
With zinc coated lid
- Lucchetti CISA di serie
CISA padlock included



PORTA ATTREZZI
TOOLS HOLDER

MODELLO MODEL	DIMENSIONI DIMENSIONS mm			TARA TARE kg	PESO PIENO CARICO TOTAL FULL LOAD WEIGHT kg	VOLUME lt	PORTATA LOAD CAPACITY kg
	L	P	H				
352	1780	550	660	84	434	550	350
352Z zincato zinc coated	1780	550	660	88	438	550	350

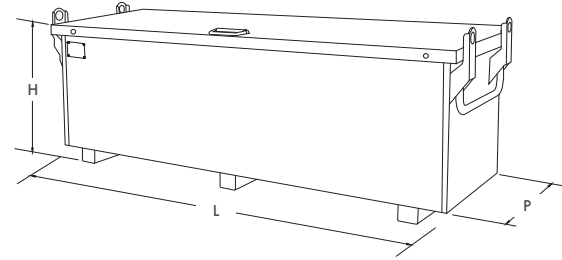

- Con coperchio zincato
With zinc coated lid
- 2 lucchetti CISA di serie
2 CISA padlock included



PORTA ATTREZZI PER NISSAN - MODELLO COMPATTO
TOOLS HOLDER FOR NISSAN - COMPACT MODEL

MODELLO MODEL	DIMENSIONI DIMENSIONS mm			TARA TARE kg	PESO PIENO CARICO TOTAL FULL LOAD WEIGHT kg	VOLUME lt	PORTATA LOAD CAPACITY kg
	L	P	H				
354N	1650	550	660	76	426	510	350
354NZ zincato zinc coated	1650	550	660	80	430	510	350

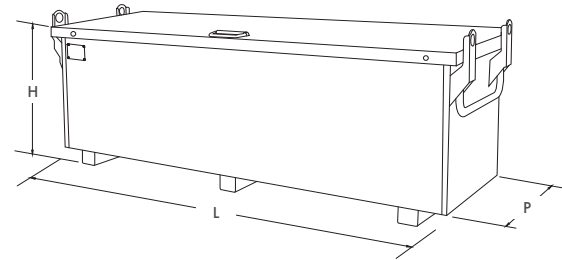

- Con coperchio zincato
With zinc coated lid
- 2 lucchetti CISA di serie
2 CISA padlock included



ACCESSORI | ACCESSORIES



99C256 - 99C187
BARRA ANTISCASSO CON LUCCHETTO
CISA ANTIFURTO PER PORTA ATTREZZI
351/351Z/352/352Z/354N/354NZ
BURGLAR BAR WITH PADLOCK
CISA THEFT PROTECTION
FOR TOOLS HOLDER
351/351Z/352/352Z/354N/354NZ



354N - 354NZ
Per venire incontro ad ogni esigenza di trasporto, abbiamo creato un porta
attrezzi specifico per furgone NISSAN: ha le stesse caratteristiche di quello
standard, ma risulta più compatto e quindi adatto per questo veicolo.
In order to meet every need of transport, we have created a specific
tool holder for NISSAN cargo van: it has the same characteristics as the
standard one, but is more compact and therefore suitable for this type
of vehicle.

PORTA ATTREZZI CON UNO SPORTELLO LATERALE
TOOLS HOLDER WITH DOOR ON ONE SIDE

MODELLO MODEL	DIMENSIONI DIMENSIONS mm			TARA TARE kg	PESO PIENO CARICO TOTAL FULL LOAD WEIGHT kg	VOLUME lt	PORTATA LOAD CAPACITY kg
	L	P	H				
353C	1900	1000	670	134	484	1070	350

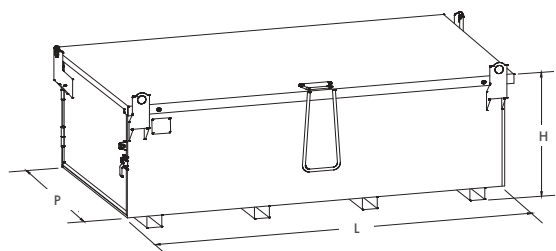

- Con coperchio zincato
With zinc coated lid
- 2 lucchetti CISA di serie
2 CISA padlock included



ARMADIO SICURBOX
SICURBOX CABINET

MODELLO MODEL	DIMENSIONI DIMENSIONS mm			TARA TARE kg	PESO PIENO CARICO TOTAL FULL LOAD WEIGHT kg	RIPIANI SHELVES	PORTATA LOAD CAPACITY kg
	L	P	H				
355	1000	700	1500	114	414	2	300

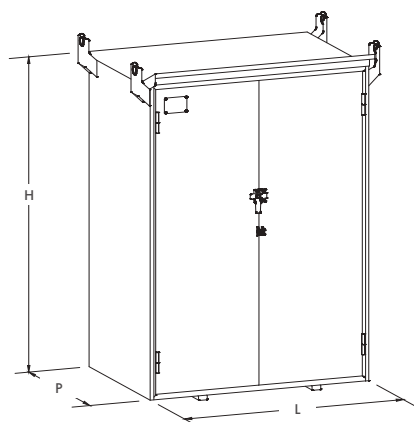

- Su richiesta con 4 ruote
On demand with 4 wheels

- Lucchetti CISA di serie
CISA padlock included



- Con due ripiani interni
With two internal shelves

ACCESSORI | ACCESSORIES



99C256 - 99C187
BARRA ANTISCASSO CON LUCCHETTO CISA ANTIFURTO
PER PORTA ATTREZZI 353C
BURGLAR BAR WITH PADLOCK CISA THEFT PROTECTION
FOR TOOLS HOLDER 353C

CONTENITORE IN METALLO
METAL CONTAINER

MODELLO MODEL	DIMENSIONI		DIMENSIONS mm			TARA TARE kg	PESO PIENO CARICO TOTAL FULL LOAD WEIGHT kg	PORTATA LOAD CAPACITY kg
	L	P	H1	H2	H3			
621	700	650	450	150	60	30	630	600

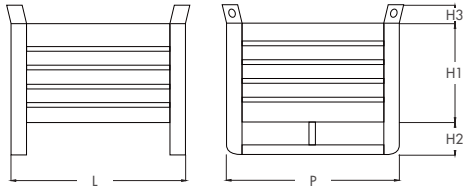

• Sovrapposizione statica
3 su 1 a pieno carico
Static overlap of 3 to 1
at full load

CONTENITORE IN METALLO A BOCCA DI LUPO
METAL CONTAINER WITH FRONTAL OPENING

MODELLO MODEL	DIMENSIONI		DIMENSIONS mm			TARA TARE kg	PESO PIENO CARICO TOTAL FULL LOAD WEIGHT kg	PORTATA LOAD CAPACITY kg
	L	P	H1	H2	H3			
622L	800	600	400	120	60	35	635	600

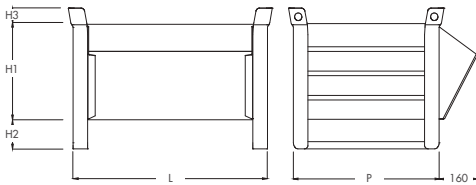

• Sovrapposizione statica
3 su 1 a pieno carico
Static overlap of 3 to 1
at full load

CONTENITORE IN METALLO
METAL CONTAINER

MODELLO MODEL	DIMENSIONI		DIMENSIONS mm			TARA TARE kg	PESO PIENO CARICO TOTAL FULL LOAD WEIGHT kg	PORTATA LOAD CAPACITY kg
	L	P	H1	H2	H3			
625	1000	800	650	150	100	92	2092	2000

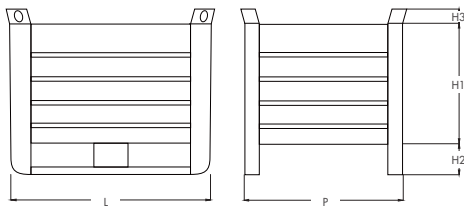

• Sovrapposizione statica
3 su 1 a pieno carico
Static overlap of 3 to 1
at full load

CONTENITORE IN METALLO CON SPORTELLO
METAL CONTAINER WITH DOOR

MODELLO MODEL	DIMENSIONI		DIMENSIONS mm			TARA TARE kg	PESO PIENO CARICO TOTAL FULL LOAD WEIGHT kg	PORTATA LOAD CAPACITY kg
	L	P	H1	H2	H3			
625S	1000	800	650	150	100	99	2099	2000

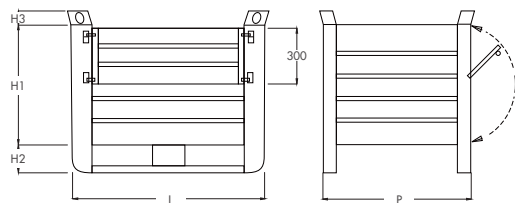

• Sovrapposizione statica
3 su 1 a pieno carico
Static overlap of 3 to 1
at full load

CONTENITORE IN METALLO
METAL CONTAINER

MODELLO MODEL	DIMENSIONI		DIMENSIONS mm			TARA TARE kg	PESO PIENO CARICO TOTAL FULL LOAD WEIGHT kg	PORTATA LOAD CAPACITY kg
	L	P	H1	H2	H3			
626	1200	800	650	150	60	64	1064	1000

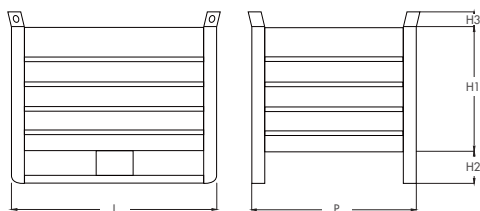

• Sovrapposizione statica
3 su 1 a pieno carico
Static overlap of 3 to 1
at full load

CONTENITORE IN METALLO CON SPORTELLO
METAL CONTAINER WITH DOOR

MODELLO MODEL	DIMENSIONI		DIMENSIONS mm			TARA TARE kg	PESO PIENO CARICO TOTAL FULL LOAD WEIGHT kg	PORTATA LOAD CAPACITY kg
	L	P	H1	H2	H3			
626S	1200	800	650	150	60	69	1069	1000

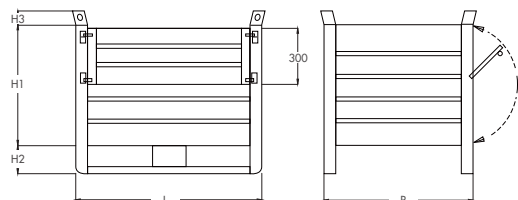

• Sovrapposizione statica
3 su 1 a pieno carico
Static overlap of 3 to 1
at full load

CONTENITORE IN METALLO PESANTE CON FONDO E BORDO INFERIORE RINFORZATO
HEAVY METAL CONTAINER WITH REINFORCED BOTTOM AND LOWER EDGE

MODELLO MODEL	DIMENSIONI		DIMENSIONS mm			TARA TARE kg	PESO PIENO CARICO TOTAL FULL LOAD WEIGHT kg	PORTATA LOAD CAPACITY kg
	L	P	H1	H2	H3			
628115XP	1500	800	750	150	100	145	1645	1500

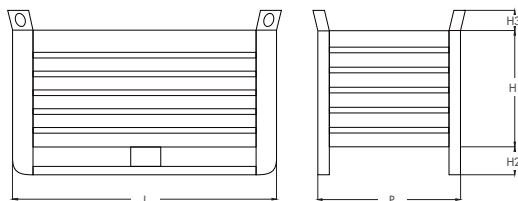

• Sovrapposizione statica
3 su 1 a pieno carico
Static overlap of 3 to 1
at full load

CONTENITORE IN METALLO
METAL CONTAINER

MODELLO MODEL	DIMENSIONI		DIMENSIONS mm			TARA TARE kg	PESO PIENO CARICO TOTAL FULL LOAD WEIGHT kg	PORTATA LOAD CAPACITY kg
	L	P	H1	H2	H3			
629	1700	800	450	150	100	85	585	500

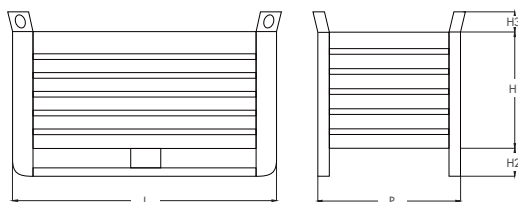

• Sovrapposizione statica
3 su 1 a pieno carico
Static overlap of 3 to 1
at full load

CONTENITORE IN RETE
MESH CONTAINER

MODELLO MODEL	DIMENSIONI DIMENSIONS mm					TARA TARE kg	PESO PIENO CARICO TOTAL FULL LOAD WEIGHT kg	PORTATA LOAD CAPACITY kg
	L	P	H1	H2	H3			
624R	1000	800	650	150	60	50	1050	1000
626R	1200	800	650	150	60	51	1051	1000

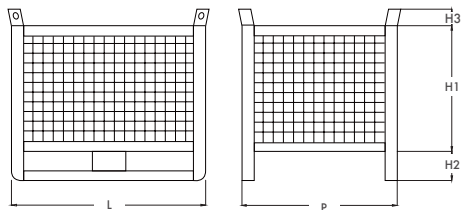

• Sovrapponibilità statica
3 su 1 a pieno carico
Static overlap of 3 to 1
at full load

CONTENITORE IN RETE CON SPORTELLO
MESH CONTAINER WITH DOOR

MODELLO MODEL	DIMENSIONI DIMENSIONS mm					TARA TARE kg	PESO PIENO CARICO TOTAL FULL LOAD WEIGHT kg	PORTATA LOAD CAPACITY kg
	L	P	H1	H2	H3			
626RS	1200	800	650	150	60	60	1060	1000

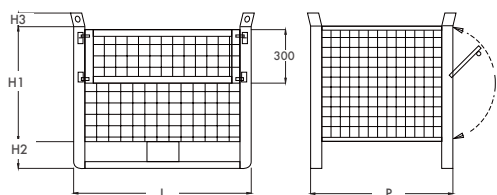

• Sovrapponibilità statica
3 su 1 a pieno carico
Static overlap of 3 to 1
at full load

CONTENITORE RIPIEGHEVOLE E SOVRAPPONIBILE IN RETE
MESH COLLAPSIBLE OVERLAPPING CONTAINER

MODELLO MODEL	DIMENSIONI DIMENSIONS mm			PORTATA LOAD CAPACITY kg
	L	P	H	
881B1ORSZ esterne external	1200	800	980	1000
881B1ORSZ interne internal	1120	730	810	1000
881B1ORSZ ripiegato collapsed	1200	800	330	-

A richiesta con 4 ruote, 2 fisse e 2 girevoli
On demand with 4 wheels, 2 fixed and 2 swiveling



• Sovrapponibilità statica
3 su 1 a pieno carico
con sportello chiuso
Static overlap of 3 to 1
at full load with closed
door



CONTENITORE IN POLIETILENE
POLYETHYLENE CONTAINER

MODELLO MODEL	DIMENSIONI DIMENSIONS mm			PORTATA LOAD CAPACITY kg
	L	P	H	
626POL	1200	800	800	500



ACCESSORI | ACCESSORIES



99C380
COPERCHIO PER CONTENITORE IN
POLIETILENE DISPONIBILE SU RICHIESTA
LID FOR POLYETHYLENE CONTAINER
AVAILABLE ON REQUEST

- Pareti dritte
Straight sides
- Con ruote
With wheels
- Impilabili
Stackable

- Impilabili a vuoto
Stackable empty



CONTENITORI A FONDO APRIBILE "COMPACT" ECO CON RUOTE
CONTAINERS WITH OPENABLE BOTTOM "COMPACT" ECO WITH WHEELS

MODELLO MODEL	DIMENSIONI DIMENSIONS mm			TARA TARE kg	PORTATA LOAD CAPACITY kg	PESO PIENO CARICO TOTAL FULL LOAD WEIGHT kg	VOLUME lt
	L	P	H				
637L05C	1195	900	815	85	500	585	500
637L10C	1195	900	1265	105	600	705	1000

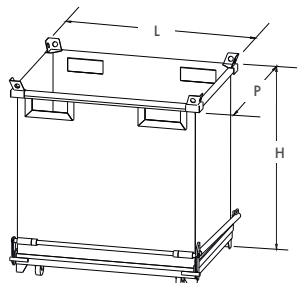

QUOTE SEDI FORCHE INTERNE | INTERNAL FORK SEATS DIMENSIONS

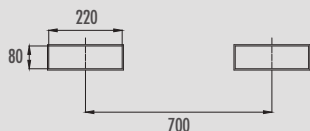

CONTENITORI A FONDO APRIBILE "COMPACT" 1000
CONTAINERS WITH OPENABLE BOTTOM "COMPACT" 1000

MODELLO MODEL	DIMENSIONI DIMENSIONS mm			TARA TARE kg	PORTATA LOAD CAPACITY kg	PESO PIENO CARICO TOTAL FULL LOAD WEIGHT kg	VOLUME lt
	L	P	H				
637	1335	1035	1205	178	1700	1878	1000
637R <i>con ruote with wheels</i>	1335	1035	1445	190	1700	1890	1000

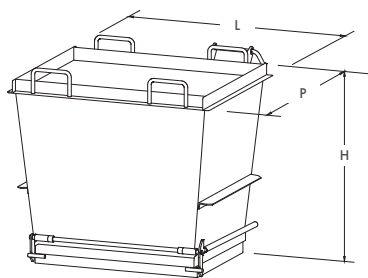

QUOTE SEDI FORCHE INTERNE | INTERNAL FORK SEATS DIMENSIONS

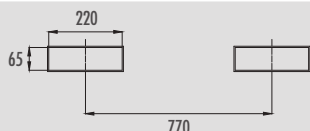

ACCESSORI | ACCESSORIES



CATENA 4 RAMI
4 LEGS CHAIN



MODELLO MODEL	CATENA CHAIN Ø	LUNGHEZZA LENGTH m	PORTATA LOAD CAPACITY kg
594B3	8	3	4250
594B4	8	4	4250

CONTENITORI A FONDO APRIBILE "COMPACT" 3000
CONTAINERS WITH OPENABLE BOTTOM "COMPACT" 3000

MODELLO MODEL	DIMENSIONI DIMENSIONS mm			TARA TARE kg	PORTATA LOAD CAPACITY kg	PESO PIENO CARICO TOTAL FULL LOAD WEIGHT kg	VOLUME lt
	L	P	H				
638	2110	1535	1330	635	5100	5735	3000

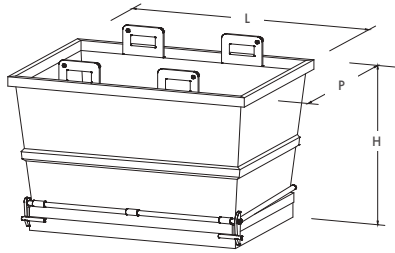

QUOTE SEDI FORCHE INTERNE | INTERNAL FORK SEATS DIMENSIONS

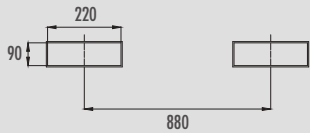

CONTENITORI A FONDO APRIBILE "COMPACT" 4000
CONTAINERS WITH OPENABLE BOTTOM "COMPACT" 4000

MODELLO MODEL	DIMENSIONI DIMENSIONS mm			TARA TARE kg	PORTATA LOAD CAPACITY kg	PESO PIENO CARICO TOTAL FULL LOAD WEIGHT kg	VOLUME lt
	L	P	H				
638L40	2250	1535	1700	712	6800	7512	4000

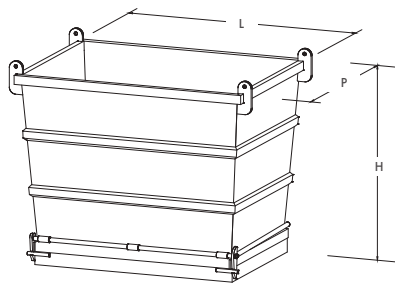

ACCESSORI | ACCESSORIES //



CATENA 4 RAMI
4 LEGS CHAIN
CE

MODELLO MODEL	CATENA CHAIN Ø	LUNGHEZZA LENGHT m	PORTATA LOAD CAPACITY kg
594B3	8	3	4250
594B4	8	4	4250



YOUTUBE VIDEO

/// CONTENITORE RIBALTABILE "PERTUTTO"
TIPPING CONTAINERS "PERTUTTO"

MODELLO MODEL	DIMENSIONI DIMENSIONS mm						PORTATA LOAD CAPACITY kg	VOLUME lit
	P1	P2	L	H1	H2	H3		
748R	930	720	750	695	850	740	580	280
750R	1250	1000	870	510	665	530	600	300
751R	1490	1130	975	655	875	715	1000	500
752R	1575	1290	1070	745	965	770	1350	750
753R	1680	1400	1070	900	1140	940	1500	1000
756R	1780	1600	1785	1115	1490	1245	2000	2300

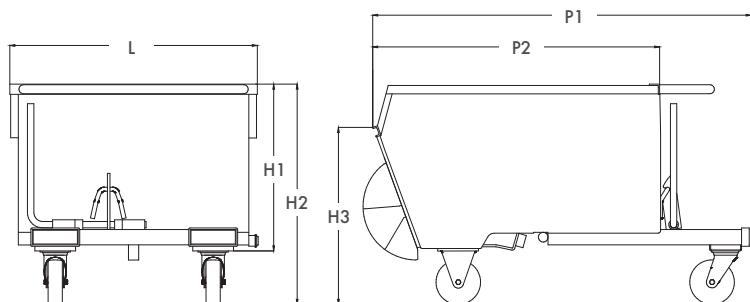

/// QUOTE SEDI FORCHE INTERNE | INTERNAL FORK SEATS DIMENSIONS

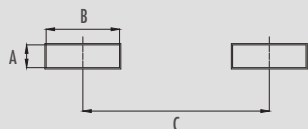

MODELLO MODEL	DIMENSIONI DIMENSIONS mm		
	A	B	C
748R	54	174	480
750R	54	174	480
751R	54	174	620
752R	54	174	620
753R	54	174	620
756R	81	212	710



/// CILINDRO IDRAULICO "SECURE SYSTEM"
HYDRAULIC CYLINDER "SECURE SYSTEM"



Dalla continua ricerca per la sicurezza negli ambienti di lavoro la Butti ha ideato il nuovo sistema "SECURE SYSTEM": cilindro idraulico, applicato a richiesta sui contenitori ribaltabili "Pertutto" per una maggiore sicurezza. Garantisce lunga vita ai cuscinetti dei montanti del carrello elevatore ed ai contenitori stessi, permettendo un ribaltamento graduale e progressivo senza violenti contraccolpi o cadute accidentali. Il cilindro "Secure System" è montato nella parte sottostante del contenitore; la sua installazione non comporta ingombro nelle dimensioni.

From the ongoing search of safety in workplaces, Butti has devised the new system "SECURE SYSTEM": hydraulic cylinder, which can be applied on request to the tipping containers "Pertutto" to have more safety. It guarantees long lifespan both for forklifts and containers themselves by allowing a gradual and progressive tipping without violent backlashes and accidental falls. The "Secure System" cylinder is placed at the bottom of the container; its installation doesn't change container dimensions.



//////
CILINDRO IDRAULICO
HYDRAULIC CYLINDER
SECURE SYSTEM



//////
COPERCHIO
COVER



YOUTUBE VIDEO

TRAMOGGIA PORTA "BIG-BAG" SMONTABILE
REMOVABLE "BIG-BAG" HOPPER

MODELLO MODEL	DIMENSIONI DIMENSIONS mm							TARA TARE kg	PORTATA LOAD CAPACITY kg
	L1xP1	L2xP2	L3xP3 utile useful	H1	H2	H3	H4		
873TB16	1600x1400	1675x1675	1440x1240	2330	2930	1530	2130	335	2000

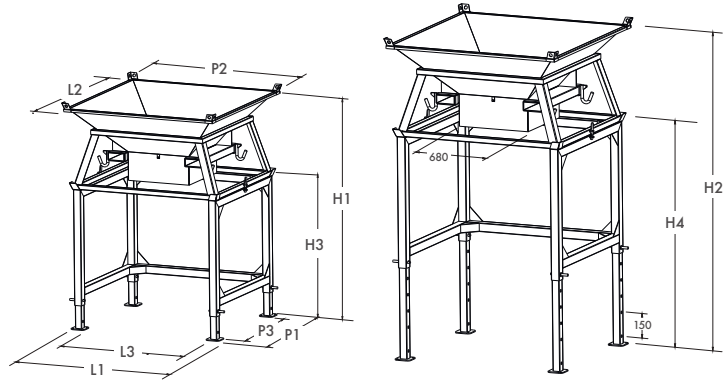

- MOVIMENTAZIONE DEL SACCO FACILITATA
EASY BAG HANDLING
- AMPIA BOCCA DI CARICO
WIDE INSERTION FUNNEL
- ALTEZZA REGOLABILE CON PASSI DA 150 mm
ADJUSTABLE HEIGHT WITH 150 mm STEPS
- ROBUSTA STRUTTURA IN ACCIAIO
STURDY STEEL STRUCTURE
- GANCI SALDATI PER FISSARE IL "BIG-BAG"
WELDED HOOKS TO FIX EASILY THE "BIG-BAG"
- 4 ATTACCHI SUPERIORI SUL BORDO DELL'IMBUTO PER SOLLEVAMENTO CON GRU A VUOTO
4 HOOKS FOR BIG-BAG PLACED DEEPER ON THE FUNNEL FOR LIFTING HIGH
- DIMENSIONI BOCCA DI SCARICO 680x680 mm
DISCHARGE DIMENSIONS 680x680 mm

QUOTE SEDI PER FORCHE INTERNE | INTERNAL FORK SEATS DIMENSIONS

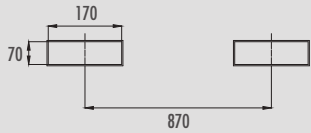

CONTENITORE PORTA "BIG-BAG" VERNICIATO
VARNISHED "BIG-BAG" CONTAINER

MODELLO MODEL	DIMENSIONI DIMENSIONS mm			PORTATA LOAD CAPACITY kg
	L	P	H	
873PB15	1070	1070	1350	1000

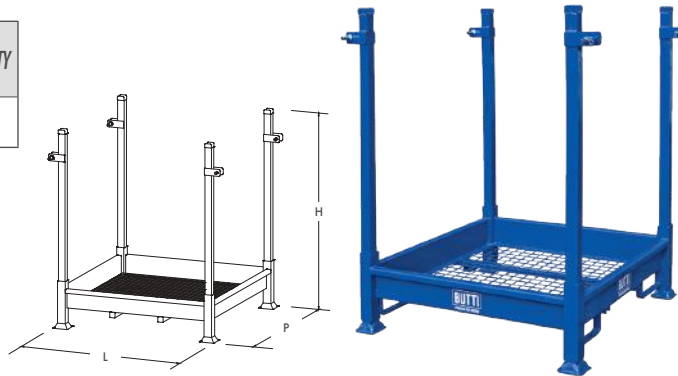

- Con piantane smontabili dotate di agganci
With removable planks with hooks

CONTENITORE PORTA "BIG-BAG" CON VASCA
"BIG-BAG" SUPPORT WITH TANK

MODELLO MODEL	DIMENSIONI DIMENSIONS mm			PORTATA LOAD CAPACITY kg
	L	P	H	
873VB15	1060	1060	1930	1000



- Grigliato zincato
Galvanized grid
- Con telaio e piantane smontabili
With removable frame and planks

SACCO "BIG-BAG" OMOLOGATO
"BIG-BAG" APPROVED

MODELLO MODEL	DIMENSIONI DIMENSIONS mm			PORTATA LOAD CAPACITY kg
	L	P	H	
99C30-	900	900	1000 / 1200 / 1700	1000 / 1200 / 1500 / 2000



SCAFFALATURE INDUSTRIALI PROFESSIONALI
PROFESSIONAL INDUSTRIAL SHELVINGS

MODELLO MODEL	DIMENSIONI DIMENSIONS mm			PORTATA PER OGNI RIPIANO LOAD CAPACITY FOR EACH SHELF kg	RIPIANI SHELVES n.
	L	P	H		
809K12P015R3	1200	500	1500	160 distribuiti/distributed	3
809K12P015R4	1200	500	2000	160 distribuiti/distributed	4
809KM12P015	1200	500	2500	160 distribuiti/distributed	5
809K12P015R6	1200	500	3000	160 distribuiti/distributed	6

- DOTATE DI SISTEMA IMBULLONATO PENSATO PER GARANTIRE LA MASSIMA SICUREZZA
EQUIPPED WITH A BOLTED SYSTEM DESIGNED TO GUARANTEE MAXIMUM SAFETY
- STRUTTURA ROBUSTA E RESISTENTE
STRONG AND RESISTANT STRUCTURE
- IL MIGLIOR RAPPORTO QUALITÀ/PREZZO SUL MERCATO
THE BEST QUALITY/PRICE RATIO ON THE MARKET

• RIPIANI AGGIUNTIVI ACQUISTABILI
SU RICHIESTA
ADDITIONAL SHELVES CAN BE
PURCHASED ON DEMAND

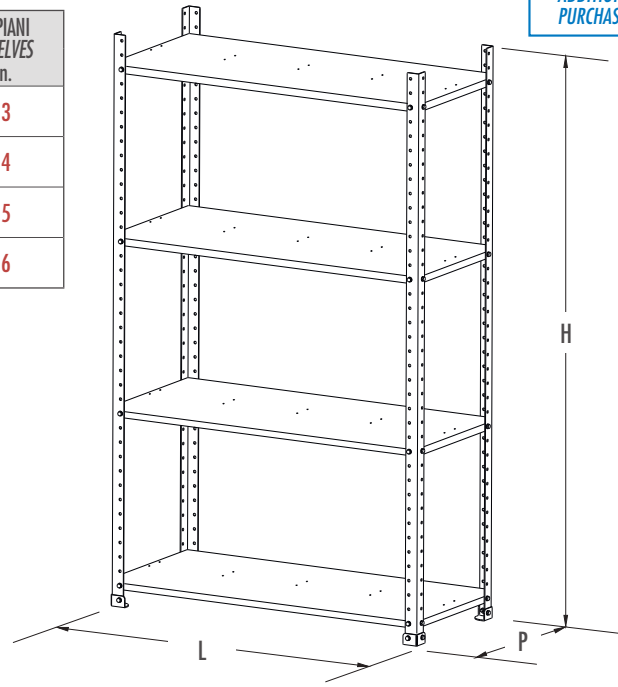

//// SCOPA INDUSTRIALE UNIVERSAL
INDUSTRIAL BROOM UNIVERSAL



YOUTUBE VIDEO

MODELLO MODEL	DIMENSIONI DIMENSIONS mm			N° DI FILI No. OF WIRES	FILE ROW	TARA TARE kg	SPAZZOLE BRUSHES
	L	P	H				
863UC20 Compact	2000	500	370	16800	3	161	Acciaio alta qualità High quality steel
865UC20 Classic	2000	800	380	28000	5	268	Acciaio alta qualità High quality steel
865UC25 Large	2500	800	380	35000	5	318	Acciaio alta qualità High quality steel



//// SCOPA INDUSTRIALE ECO UNIVERSAL
INDUSTRIAL BROOM UNIVERSAL

MODELLO MODEL	DIMENSIONI DIMENSIONS mm			N° DI FILI No. OF WIRES	FILE ROW	TARA TARE kg	SPAZZOLE BRUSHES
	L	P	H				
866N0520 Compact	2000	500	370	14400	3	106	Polipropilene alta qualità High quality polypropylene
866N1020 Classic	2000	800	380	24000	5	176	Polipropilene alta qualità High quality polypropylene
866N1025 Large	2500	800	380 </td <td>30000</td> <td>5</td> <td>213</td> <td>Polipropilene alta qualità High quality polypropylene</td>	30000	5	213	Polipropilene alta qualità High quality polypropylene



//// QUOTE SEDI FORCHE INTERNE | INTERNAL FORK SEATS DIMENSIONS

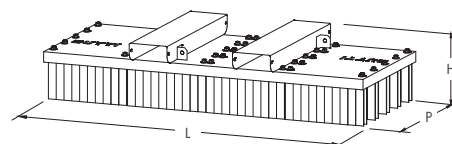
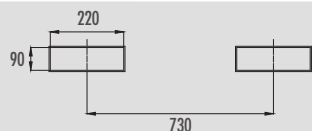

ACCESSORI | ACCESSORIES



//////
KIT DI RICAMBIO SPAZZOLE IN ACCIAIO O POLIPROPILENE DI ALTA QUALITÀ
HIGH QUALITY STEEL OR POLYPROPYLENE BRUSH REPLACEMENT KIT

// DEPOSITO PER 1 CISTERNETTA
OUTDOOR CONTAINER FOR 1 TANK

MODELLO MODEL	DIMENSIONI DIMENSIONS mm			VOLUME lt
	L	P	H	
8080D1C18	1350	1660	1810	1100

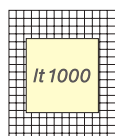

// VASCA DI CONTENIMENTO PER 2 CISTERNETTE
SPILL CONTAINMENT PALLET FOR 2 TANKS

MODELLO MODEL	DIMENSIONI DIMENSIONS mm			CAPACITÀ DI STOCCAGGIO STORAGE CAPACITY	VOLUME lt
	L	P	H		
8070V2C	2720	1650	350	2 cisterne da 1000 l su grigliato 1x2000 lt tanks on grid	1000

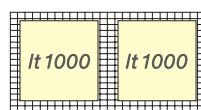

• Grigliato zincato a caldo
Hot-dip galvanized grid

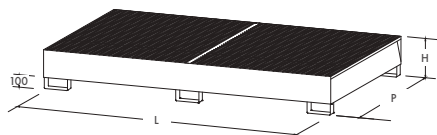

// CISTERNA MULTIUSO PER STOCCAGGIO ACQUA POTABILE O LIQUIDI VARI CON SUPPORTO
MULTI-PURPOSE TANK FOR STORAGE OF DRINKABLE WATER OR VARIOUS LIQUIDS WITH SUPPORT

MODELLO MODEL	DIMENSIONI DIMENSIONS mm			TARA TARE kg	PESO PIENO CARICO TOTAL FULL LOAD WEIGHT kg	VOLUME lt
	L	P	H			
614 cisterna tank	1000	1200	1165	56	1221	1000
614S supporto support	1150	955	700	30	-	-
614RI rigenerata regenerated	1000	1200	1165	56	1221	1000

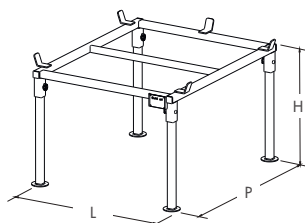

• Possibilità di acquisto di modelli rigenerati
Possibility of purchasing regenerated models

**RIGENERATA
REGENERATED**

// ACCESSORI | ACCESSORIES



915
POMPA
PORTATA 40 LT
PUMP
FLOW RATE 40 LT



99C072
RIDUZIONE IN ALLUMINIO
CON RUBINETTO DA 1"
ALLUMINIUM REDUCTION
WITH 1" DISCHARGE VALVE

////// POMPA IN ACCIAIO PROFESSIONALE
PROFESSIONAL STEEL SPRAYER

MODELLO MODEL	VOLUME lt
618	5
619	10



Pompa in acciaio professionale studiata per facilitare tutte le operazioni di distribuzione di oli disarmanti in edilizia e di irrorazione, diserbo e disinfestazione nel giardinaggio
Professional steel sprayer designed to simplify all the operations of distributing disarming oils in construction and spraying, weeding and disinfestation in gardening



• PISTOLA CON ATTACCO GIREVOLE E GRUPPO FINALE IN OTTONE PROFESSIONALI
PROFESSIONAL BRASS DISCHARGE VALVE WITH SWIVEL ATTACHMENT AND COMPLETE SPRAYLANCE

////// ACCESSORI POMPA IN ACCIAIO PROFESSIONALE
ACCESSORIES FOR PROFESSIONAL STEEL SPRAYER

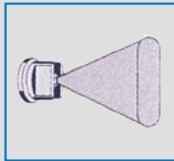

99C138
UGELLO FINALE IN OTTONE
BRASS NOZZLE FLAT SPRAY



99C147
POMPA DI COMPRESSIONE
IN OTTONE
BRASS AIR PUMP



99C141
LANCIA IN ALLUMINIO
ALUMINIUM LANCE
50 CM



99C143
PROLUNGA IN OTTONE
BRASS EXTENSIONS
50 CM

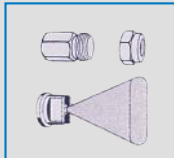

99C140
UGELLO COMPLETO
IN OTTONE
COMPLETE BRASS
NOZZLE FLAT SPRAY



99C148
VALVOLA DI SICUREZZA 6 BAR
SAFETY VALVE 6 BAR



99C144
PISTOLA PER POMPA
DISCHARGE VALVE



99C149
MANOMETRO 6 BAR
PRESSURE GAUGE 6 BAR



99C398 | 99C399
LANCIA SUPER LEGGERA IN ALLUMINIO
SUPER LIGHT ALUMINIUM LANCE
130 CM | 100 CM



99C428
LANCIA ESTENSIBILE
EXTENSIBLE LANCE
75X150 CM



99C146
SERIE DI GUARNIZIONI
SERVICE KIT



99C157
TUBO POMPA CON RACCORDO
SPRAYER HOSE WITH FITTING



99C222
COPERTICCHIO AD IMBUTO
PER POMPA
FUNNEL LID FOR PUMP



99C248
GUARNIZIONE
PER COPERTICCHIO
GASKET FOR FUNNEL LID

////// ELEKTRO-12 POMPA PROFESSIONALE CON BATTERIA AL LITIO IDEALE PER LA SANIFICAZIONE
ELEKTRO-12 LITHIUM BATTERY POWERED PROFESSIONAL SPRAYER FOR SANITIZING

MODELLO MODEL	VOLUME lt
619EL12	12



Pompa a spalla elettrica con batteria ricaricabile al litio, idonea per irrorazione, diserbo, disinfestazione, trattamenti in serra, uso di insetticidi, fungicidi, protezione ambienti, ospedali, scuole, capannoni agricoli e industriali
Electric sprayer wearable on shoulders with rechargeable lithium battery, suitable for spraying, weeding, disinfestation, treatments in glasshouses, use of insecticides and fungicides, protection of any setting, hospitals, schools, agricultural and industrial sheds



• PISTOLA CON ATTACCO GIREVOLE E GRUPPO FINALE IN OTTONE PROFESSIONALI
PROFESSIONAL BRASS DISCHARGE VALVE WITH SWIVEL ATTACHMENT AND COMPLETE SPRAYLANCE

////// POMPA ECOPUMP
ECOPUMP SPRAYER

MODELLO MODEL	VOLUME lt
619EP10	10



Pompa studiata per facilitare tutte le operazioni di irrorazione, diserbo e disinfestazione in campo edile e nel giardinaggio
Sprayer designed to simplify all spraying, weeding and pest control operations in the construction field and in gardening





// PORTA SECCHI "LIGURIA"
"LIGURIA" BUCKET HOLDER

MODELLO MODEL	TIPO TYPE	DIMENSIONI DIMENSIONS mm		TARA TARE kg	PESO PIENO CARICO TOTAL FULL LOAD WEIGHT kg	PORTATA LOAD CAPACITY kg
		L	H			
601	1 secchio piece	500	722	8	108	100



// PORTA SECCHI "FOX" CON RUOTE
"FOX" BUCKET HOLDER WITH WHEELS

MODELLO MODEL	TIPO TYPE	DIMENSIONI DIMENSIONS mm		TARA TARE kg	PESO PIENO CARICO TOTAL FULL LOAD WEIGHT kg	PORTATA LOAD CAPACITY kg
		L	H			
601R	1 secchio piece	600	960	20	120	100



• AUTORIBALTANTE
SELF DUMPING

SEQUENZA DI RIBALTAMENTO PORTA SECCHI "FOX"
"FOX" BUCKET HOLDER DUMPING SEQUENCE

1



2



3



// PORTA SECCHI "MILAN"
"MILAN" BUCKET HOLDER

MODELLO MODEL	TIPO TYPE	DIMENSIONI DIMENSIONS mm		TARA TARE kg	PESO PIENO CARICO TOTAL FULL LOAD WEIGHT kg	PORTATA LOAD CAPACITY kg
		L	H			
601Q	1 secchio piece	440	700	8	108	100



// PORTA SECCHI
BUCKET HOLDER

MODELLO MODEL	TIPO TYPE	DIMENSIONI DIMENSIONS mm		TARA TARE kg	PESO PIENO CARICO TOTAL FULL LOAD WEIGHT kg	PORTATA LOAD CAPACITY kg
		L	H			
602	2 secchi pieces	820	438	5	80	75
603	3 secchi pieces	760	438	7	119	112
604	4 secchi pieces	820	438	8	158	150



// ACCESSORI | ACCESSORIES



99C184
MASTELLO NERO PER "FOX"
BLACK BUCKET FOR "FOX"



99C337
MASTELLO QUADRATO PER "MILAN"
BLACK BUCKET FOR "MILAN"

CAVALLETTO "PRATIKO" ULTRALEGGERO E CERTIFICATO PER L'UTILIZZO
"PRATIKO" TRESTLES ULTRALIGHT AND CERTIFIED FOR USE

MODELLO MODEL	DIMENSIONI DIMENSIONS mm				TARA TARE kg	PESO PIENO CARICO TOTAL FULL LOAD WEIGHT kg	PORTATA MAX. MAX CAPACITY kg
	L	P1	P2	H			
157	900	760	220	900	8	158	150

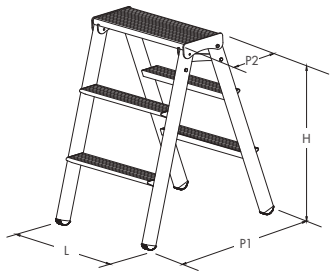

• PESA SOLO 8 KG
WEIGHT ONLY 8 KG



PERICOLO!
DANGER!



• Pieghevole
Folding

CAVALLETTO "PICASSO" ULTRALEGGERO E CERTIFICATO PER L'UTILIZZO
"PICASSO" TRESTLES ULTRALIGHT AND CERTIFIED FOR USE

MODELLO MODEL	DIMENSIONI DIMENSIONS mm				TARA TARE kg	PESO PIENO CARICO TOTAL FULL LOAD WEIGHT kg	PORTATA MAX. MAX CAPACITY kg
	L	P1	P2	H			
157P	600	760	220	900	7	157	150



BARELLE D60 - LA PIÙ ROBUSTA
STACKING STILLAGE D60 - THE MOST ROBUST

MODELLO MODEL	DIMENSIONI DIMENSIONS mm				TARA TARE kg	PORTATA LOAD CAPACITY kg	PESO PIENO CARICO TOTAL FULL LOAD WEIGHT kg
	L int	P int	H1	H2			
170N piccola small	1440	715	880	720	34	500	534
171N grande big	1440	1040	880	720	37	1000	1037

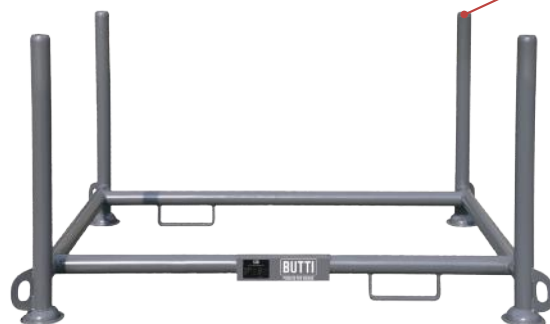
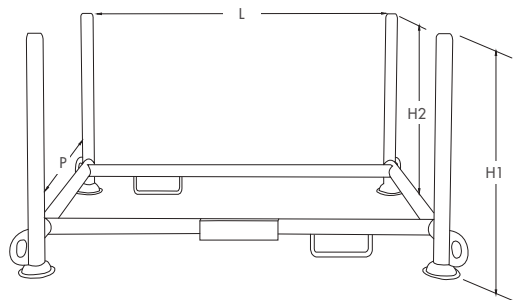

• Tubo da Ø 60 mm
rastremato
Ø 60 mm tapered tube



• Robuste sedi per
l'inforcamento che
permettono alla barella
di non scivolare durante
gli spostamenti
Robust seats for
forklifting that allow
the stacking stillage not
to slip during travel

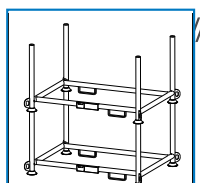

• Sovrapponibili
Stackable

- Progettate per resistere e dare sicurezza in cantiere
Designed to withstand and provide security on site
- Costruite in acciaio di alta qualità
Built in high quality steel
- Tubo da Ø 60 mm - spessore 3 mm
Ø 60 mm tube - 3 mm thick
- 4 robuste asole per il sollevamento con gru
4 sturdy eyelets for lifting with a crane
- Sedi saldate antisivolo per l'inforcamento
Non-slip welded seats for forklifting

TRANSPALLET BIRULLO
DUAL ROLLER TRANSPALLET

MODELLO MODEL	DIMENSIONI DIMENSIONS mm				PORTATA LOAD CAPACITY kg
	L	P	H max	H min	
700	1150	525	200	85	2500

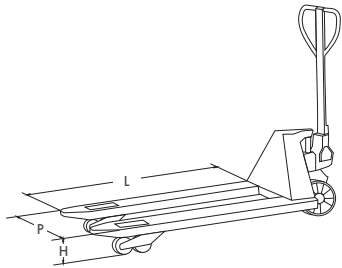

ASSORBENTE GRANULARE PER PRODOTTI LIQUIDI E OLEOSI
GRANULAR ABSORBENT FOR LIQUID AND OILY PRODUCTS

MODELLO MODEL	CARATTERISTICHE FEATURES
909G0512	Granulare fine 12 Kg (secchio) Fine granular 12 Kg (bucket)



YOUTUBE VIDEO



ACCESSORI PER LA SICUREZZA DEL LAVORATORE
ACCESSORIES FOR WORKER SAFETY

MODELLO MODEL	CARATTERISTICHE FEATURES
99C201	KIT IMBRAGATURA DA LAVORO: Imbragatura per il corpo + Cordino di trattenimento + Moschettone HARNESS KIT: Body harness + Retention rope + Carabiner
99C376	Caschetto alta sicurezza, a richiesta con occhiali High safety security helmet, on request with glasses

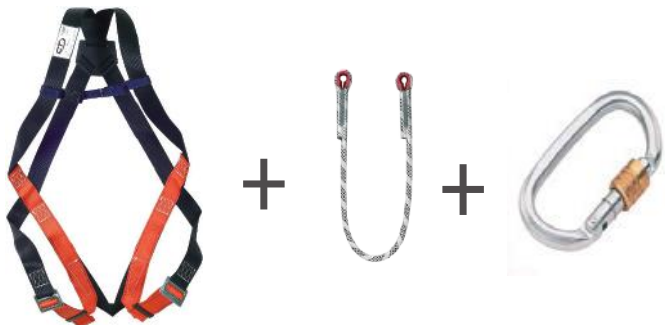

• Occhiali a richiesta
Glasses on request

////// TETTOIA PER PROTEZIONE BETONIERA
CANOPY FOR CONCRETE MIXER COVERING

MODELLO MODEL	DIMENSIONI DIMENSIONS mm			TARA TARE kg
	L	P	H	
482 aperta opened	2480	2370	3000	180
482 chiusa closed	2370	1530	300	180

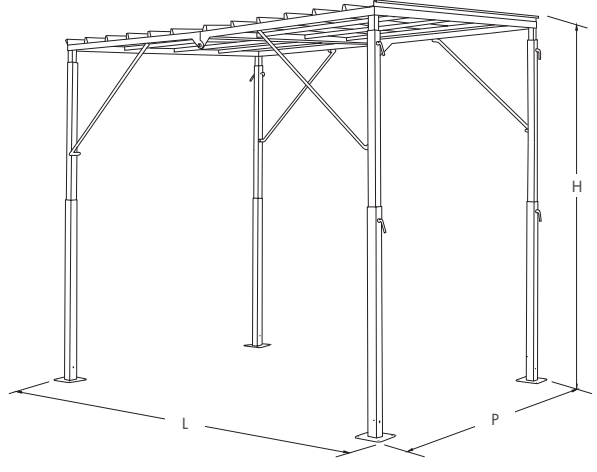

////// MATTA PROFESSIONALE
PROFESSIONAL PENCIL

MODELLO MODEL
665



- A pulsante, con temperino e mina inclusa da Ø 5,6 mm
With pushbutton, pencil sharpener and lead Ø 5,6 mm included



- Non si spezza
It doesn't break

- Non ha bisogno di temperino e disegna linee spesse o sottili
Doesn't need a pencil sharpener and it draws both thin and thick lines

////// MATTA "SEMPRE PRONTA"
"SEMPRE PRONTA" PENCIL

MODELLO MODEL
663



////// DOPPIO METRO BUTTI | STABILA
FOLDING RULER BUTTI/STABILA

MODELLO MODEL
617S





YOUTUBE VIDEO

SPAZZANEVE FISSO CON RASCIANTE IN ACCIAIO NON INTERCAMBIABILE
FIXED SNOWPLOUGH WITH STEEL SCRAPER NOT INTERCHANGEABLE

MODELLO MODEL	DIMENSIONI DIMENSIONS mm			AMMORTIZZATORI SHOCK ABSORBERS	POSIZIONE RASCIANTE SCRAPER POSITION	RASCIANTE SCRAPER
	L	P	H			
87814	1415	1330	700	1	20° verso destra 20° on the right	Acciaio Steel

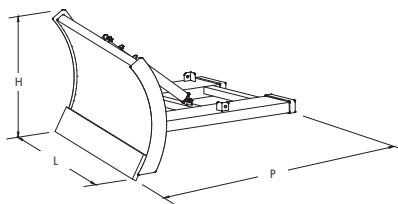

//// QUOTE SEDI FORCHE INTERNE | INTERNAL FORK SEATS DIMENSIONS

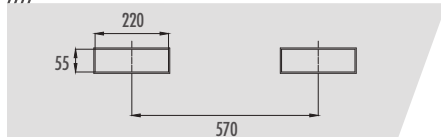

SPAZZANEVE ORIENTABILE CON RASCIANTE IN POLIURETANO INTERCAMBIABILE
ADJUSTABLE SNOWPLOUGH WITH INTERCHANGEABLE POLYURETHANE SCRAPER

MODELLO MODEL	DIMENSIONI DIMENSIONS mm			AMMORTIZZATORI SHOCK ABSORBERS	POSIZIONE RASCIANTE SCRAPER POSITION	RASCIANTE SCRAPER
	L	P	H			
87815ORG	1515	1360	740	1	0°-15°-30° verso destra o sinistra on the right or left	Poliuretano Polyurethane
87823ORG	2265	1800	740	2	0°-15°-30° verso destra o sinistra on the right or left	Poliuretano Polyurethane



//// QUOTE SEDI FORCHE INTERNE | INTERNAL FORK SEATS DIMENSIONS



//// QUOTE SEDI FORCHE INTERNE | INTERNAL FORK SEATS DIMENSIONS

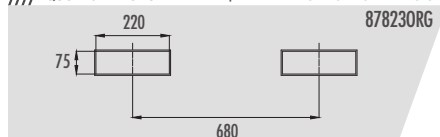

SPARGISALE PROFESSIONALE A MANO
PROFESSIONAL MANUAL SALT SPREADER

MODELLO MODEL	VELOCITÀ DI LAVORO WORKING SPEED km/h	PORTATA LOAD CAPACITY kg
876K25	1/4	25
876K50	1/4	50



CARRELLO SPARGISALE PROFESSIONALE A TRAINO
PROFESSIONAL TOWING SALT SPREADER

MODELLO MODEL	VELOCITÀ DI LAVORO WORKING SPEED km/h	PORTATA LOAD CAPACITY kg
877K150	10/15	150



YOUTUBE VIDEO

PANTHER FRESANEVE
PANTHER SNOW BLOWER

MODELLO MODEL	DIMENSIONI DIMENSIONS mm			MOTORE ENGINE	VELOCITÀ MOTORE ENGINE SPEED min	POTENZA MOTORE ENGINE POWER cv hp
	L	P	H			
879PFD2 Panther	800	700	1240	Motore a scoppio monocilindrico raffreddato ad aria Briggs & Stratton Briggs & Stratton air cooled single cylinder engine	3000	6,5



MODELLO MODEL	DIMENSIONI DIMENSIONS mm			RAGGIO DI AZIONE ACTION RANGE mm
	L	P	H	
879SF70 Turbo fresa Snow blower	740	750	880	700







SOLUZIONI PER L'EDILIZIA
SOLUTIONS FOR BUILDING

