

the electronic music magazine

# Synapse



EVE KESSLER

## Roger Powell & Todd Rundgren

Audio Video Synthesis  
Steve Hillage and Friends  
Synthesizers on the Eco-Front



# SOUND~A~ROUND

QUAD PANNER MODEL **QP~1**

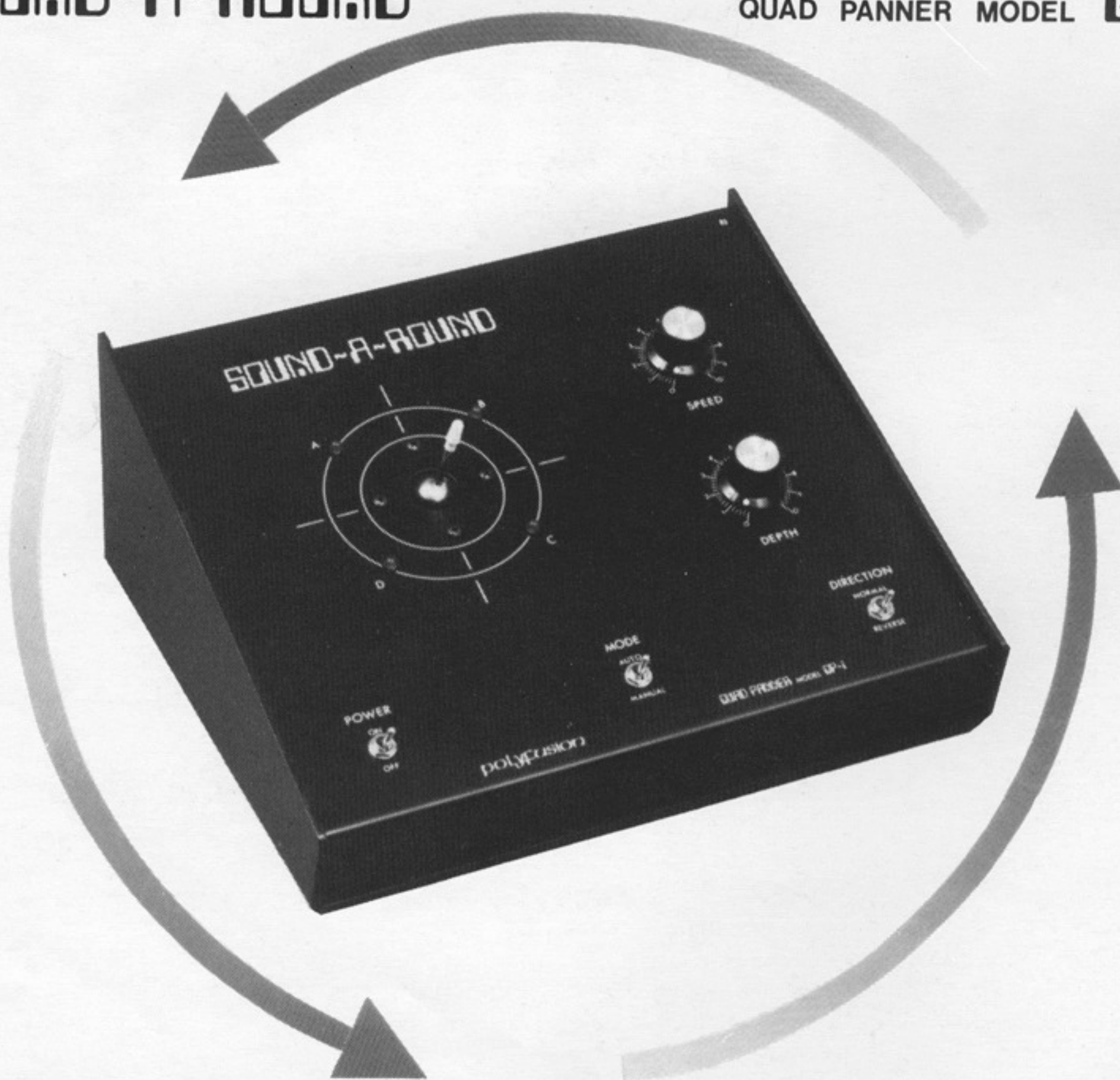

The SOUND-A-ROUND can turn your quad system into a dynamic, moving sound environment.

From a sublimely slow shift of sound from channel to channel to a neck wrenching spin, you can precisely control the speed of revolution with either the panel control or optional foot pedal.

From barely perceptible changes in loudness to a blatant jumping effect from channel to channel, the depth can be controlled with either the panel control or optional foot pedal.

The direction of revolution can be instantly reversed with a switch.

Four LEDs let you know what the SOUND-A-ROUND is doing for you—indicating speed, direction, and channel levels.

A joystick control allows you to precisely maneuver the sound by hand if you prefer.

The SOUND-A-ROUND is available in the standard one input to four output configuration and also in two and four input versions.

All this unique and stunning capability for only \$299.95. Ask your dealer for more information or write to:

# polyfusion

160 Sugg Road, Buffalo, New York 14225 (716) 631-3790



Editors  
Angela Schill, Douglas Lynner

Art Director  
Chris August

Photography  
Bill Matthias

Correspondents  
Northern California: Phil Loarie  
Connecticut: Chuck Scribner  
Maryland: Paul Medlock  
New York: Carter Thomas  
San Diego: Steve Roach

Contributing Writers  
Craig Anderton  
Arpad Benares  
Alex Cima  
Tom Davey  
Peter Hillen  
Jerry Hunt  
Will Jackson  
Danny Sofer  
Phil Terr  
Carter Thomas  
Richard Waldholm

Contributing Artist  
Sue Denim

Contributing Photographers  
Eve Kessler  
Rex Weyler  
Michael Glascoe  
Douglas Taylor  
Fred Leak

SYNAPSE MAGAZINE is published bi-monthly by Synapse Publishing Co., 2829 Hyans Street, Los Angeles, California 90026. (213) 383-7933. No part of this magazine may be reproduced, either mechanically or by other means, without the written permission of the publisher. Copyright 1977 by Synapse Publishing Co. Printed in the United States of America.

MANUSCRIPTS: We cannot be responsible for the return of any unsolicited manuscripts, photographs, artwork or scores. All contributions are welcome and should be addressed to: SYNAPSE MAGAZINE, 2829 Hyans Street, Los Angeles, California 90026.

RETAIL SALES: Synapse is available at bulk rates for retail sales. Interested dealers should contact Synapse (213) 383-7933.

SUBSCRIPTIONS: U.S. and Canada \$6.00 for six issues, foreign subscriptions \$7.50 for six issues. All subscriptions must be in U.S. funds. Single copy newsstand price is \$1.25.

CHANGE OF ADDRESS: Notify SYNAPSE MAGAZINE/SUBSCRIPTION DEPARTMENT, 2829 Hyans Street, Los Angeles, California 90026. Please send both the old and new addresses, and if possible, the mailing label from a copy of SYNAPSE.



page 12



page 16



page 20

## FEATURES

<b>Buying Your First Synthesizer</b>	
Alex Cima .....	8
<b>New York Public Access Synthesizer Studio</b>	
Phil Terr .....	8
<b>Los Angeles Center for Electronic Music</b>	
Phil Terr .....	10
<b>Steve Hillage &amp; Friends</b>	
Doug Lynner .....	12
<b>Synthesizers on the Eco-Front</b>	
Will Jackson .....	16
<b>Todd Rundgren &amp; Roger Powell</b>	
Carter Thomas .....	20
<b>The Left Hand &amp; the Synthesizer</b>	
Craig Anderton .....	24
<b>Audio-Video Synthesis</b>	
Jerry Hunt .....	26
<b>Constructing a Programmer</b>	
Arpad Benares .....	30

## DEPARTMENTS

no. 6 .....	2	Performance .....	33
Letters .....	2	Synthesis .....	34
What's Happening .....	4	Equipment Review .....	36
Discola .....	6	Listings .....	40
Computers .....	32	Classified Ads .....	40



# no.6

Those of you who prefer reading magazines from the middle first will find an interview with Todd Rundgren and Roger Powell, who together with Kasim Sulton and John Wilcox form the group Utopia. Powell uses a specially designed portable keyboard that triggers a polyphonic synthesizer. After many months of preparation, Utopia is launching a multi-media tour. Their tour begins March 2nd and after 70 days on the road they will break to record their next album. Then it's back on the road for the second 60 city leg of their tour.

It was with the assistance of Todd Rundgren and Roger Powell that Steve Hillage (formerly of Gong) recorded his solo album "L". Inside is a look at Steve and three other members of his band—Miquette Giraudy, Basil Brooks, and Phil Hodge, interviewed by Synapse while awaiting the continuation of their American tour.

Synthesist Danny Sofer discusses the beginning elements of synthesis in his new column, "Synthesis", (what else could it be called?). Between writing and reviewing for Synapse, Danny keeps himself busy performing with LEM and also has a tune on the program of Laserium II.

Synapse is enlarging its distribution through musical instrument retail stores and you could help. Let the retailers in your area know that you would like to be able to buy Synapse in their store and be sure to give them our address.

# LETTERS

## Mushroom

It's good to see that someone finally got off their ass and decided to put out a magazine devoted to electronic music.

Your magazine is very interesting and informative. And I can't tell you how exciting it is to get up to date information on the west coast electronic music scene. Things are much the same over here, with public access facilities opening at a nominal charge to the public down in Soho, concertizing all over New York and synthesis specialists moving into recording studios. As Bob Walter of Sound Arts put it, there are "some almost disquieting indications that things may suddenly mushroom". I hope in the months ahead you will be able to inform your readers about some of the goings on here and abroad.

The interest in electronic music is so intense here that I'm sure your magazine would be a smash success if more people knew about it. May I suggest you contact Manny's Music and Sam Ash Music to see if they would carry Synapse? I know you can obtain other music journals there and it strikes me Synapse would look quite at home in Sam Ash's synthesizer room.

I wish you people the best of luck. We desperately need this type of communication to in some way coordinate the artistic and technological explosion we find ourselves in. Thanks.

Richard Einhorn  
New York, New York  
P.S. Recently I was appointed Composer in Residence at Soundmixers Studios, a brand new recording complex (four twenty four track recording studios with sync equipment for film music as well as abstract) and am writing music for some off-off Broadway plays and films.

## Lacking

I read your magazine from cover to cover, found the articles well written but lacking in technical explanation of ideas, presented by Gleeson for example. That interview might have contained some valuable historical data, in light of Tomita's simultaneous realization, concerning techniques and equipment used.

Jon Dattorro  
Boston, Massachusetts

## The Future?

I would like to know if you envision any type of electronic music convention in the future. I don't understand why we can't get it together like the computer groups and have a local meeting periodically.

Barry Klein  
Anaheim, California

*We think it's an excellent idea and will assist in any way we can.*—Ed.

## Lost in Space

Fellow Spacers,

I'm Magic Moe, here we go. I live in Fullerton and have a rock band called "French Lick" playing land-

scapes and other shapes. I have a disc called "Glider". I studied for two years in Paris and would like to return to traveling. My equipment is whatever I get my hands on. I just finished a movie soundtrack. I'm 24 earth years singing bossa-nova, blue bodies, and purple nipples.

Love to you, many modulations.

Magic Moe

Fullerton, California

*Thanks, Moe. It's good to know there are people like you out there.*—Ed.

## Eager Beaver

You've got a very interesting and informative magazine with just the right mix of art and technology. I'm a relative beginner in electronic music and am eager to use all of the ideas and information I can get my hands on in order to develop my own musical style.

Tim Best

El Cajon, California

## Matrix Keyboard

I would first like to say, I enjoy your magazine very much. Just recently, I purchased an EML 200/300 Synthesizer with a "Matrix Keyboard" (e.g., the keys are arranged in a matrix fashion. An example would be 4 by 4 matrix which equals 16 keys. Each key has a tuning spread.) The matrix keyboard layout enables a composer to fashion his/her own keyboard tunings. I have developed my own tunings for my specific keyboard, however, I would be interested in any informa-



tion other composers would have to offer, who have had experience with matrix keyboards. Any information would be most appreciated.

Thank You,  
Tim Conrardy  
19316 Falmouth Ct.  
Saratoga, Cal. 95070  
(408) 255-5610

#### Up Your Alley

Saw your magazine while in the University of Oregon Moog lab. It was a copy of No. 4, great issue. Bob Easton, TONTO, etc., blew me away to find a mag right up my alley.

I am a drummer with plans to utilize electronics onstage with both percussion synthesization and abstract mood setting sounds. SYNAPSE energizes my enthusiasm!

Rick McMillan  
Springfield, Oregon

#### Monophonic/Polyphonic

My electronic music instructor introduced me to your magazine, and as an ex-electrical engineer I can greatly appreciate the technical challenges in the course of my study. Your magazine would greatly aid me in my quest for new and different methods for sound synthesis. I presently own an EML 500 keyboard synthesizer, and would like some information concerning polyphonic conversion for it.

James M. Mann  
Knoxville, Tennessee

*Dale Blake of EML says that the EML Poly-Box is the only available method at this time.*—Ed.

#### Help

I am just getting into electronic music and electronics and am trying to

figure out the best and cheapest way to obtain equipment. So what I am trying to do is find out what all is involved in putting the equipment together from scratch. If I can get P.C. layouts, it seems that it can be done with little problems and at a fraction of the cost. The problem though, is getting the P.C. layouts or even schematics for well designed equipment. So I would appreciate it very much if you would help me to find out more about this situation. Thank you.

Dana Harden  
54-083 Hauula MNSTD  
Hauula, Hawaii 96717

*Our listings column is a good source for the information you request and we have included your address so that readers with information can contact you.*  
—Ed.

#### More

Your magazine was just what I was looking for. Information I found particularly useful were the statements by Wright and Gleeson concerning specific equipment used.

I would also like to see more short articles featuring various signal processing equipment (besides VCO, VCF, Envelope Generators etc.) for special effects, the possibilities of combining outputs; more on digital memory keyboards, sequencers. In short, keep up the good work!

Larry Julien  
Alameda, California  
P.S. Don't forget recording techniques for multi-trackers. You will be interested in the digital sequencer reviews in the next issue of Synapse.  
—Ed.

# IT'S HERE

## and it's time for keyboard players to move over!



THE SLAVEDRIVER turns guitar players into synthesizer players! It's the missing link, and goes between your guitar and a synthesizer. Makes almost any synthesizer follow a guitar player's technique—copies pitch, dynamics, and even triggers synthesizer filter sweeps. And it'll enslave just about any synthesizer made in America! But best of all, it works with your own guitar. The SLAVEDRIVER runs synthesizers the way a guitar player would want it to—follows bends, slides, and right hand technique with

super-fast response. Hear your guitar performance with all the sounds your synthesizer can give you, and more you'll never hear—unless you use a guitar to do 'em! Ask your dealer to get you a SLAVEDRIVER to try out. Or contact Bob Easton at 360 SYSTEMS for all the facts.

360  
SYSTEMS

2825 HYANS STREET • LOS ANGELES,  
CALIFORNIA 90026 • (213) 384-8447



# WHAT'S HAPPENING

Congratulations to Greg Leslie of Ponca City, Oklahoma, the winner of the Synapse/Star Instruments Inc. Giveaway of the Synare Percussion Synthesizer. Greg, a Radio, T.V. and Film major at Oklahoma State University, Stillwater, is an announcer for KVRO, the college FM station and recently completed a design for a digital trumpet controller. Greg, five years experienced in electronic music, composes using a PAIA synthesizer as well as modules of his own design. . .

From Strider Systems, Inc. comes the DCS-1, a computer controlled portable polyphonic synthesizer. Included in the system are 12 audio frequency oscillators, a 48 channel envelope generator, 3 state-variable filters, a 49 key polyphonic keyboard with programmable split, a 16-key digital keyboard with

l.e.d. display, a 16-key programmable effects keyboard, 10 patch digital memory, 4 independent 256 note sequences, and a tape cassette for bulk storage of patches, sequences and computer programs. . . . .

The Los Angeles Center for Electronic Music is now offering a "first" in electronic music education: a polyphonic guitar synthesizer class featuring Bob Easton of 360 Systems and Jazz guitarist Lee Ritenour. The class will be held during the March and June term along with a forty hour comprehensive and a fifteen hour advanced synthesizer course. Write or call them for more details. . . . .

EML has recently released the Poly-Box as a means of adding polyphonic capabilities to any existing synthesizer. The Poly-Box features pitch fol-

lowing that will track your oscillator throughout the audio range in addition to copying vibrato, pitch bend and portamento. The Poly-Box offers 26 simultaneously available pitches at semitone intervals as well as a one octave keyboard and memory . .

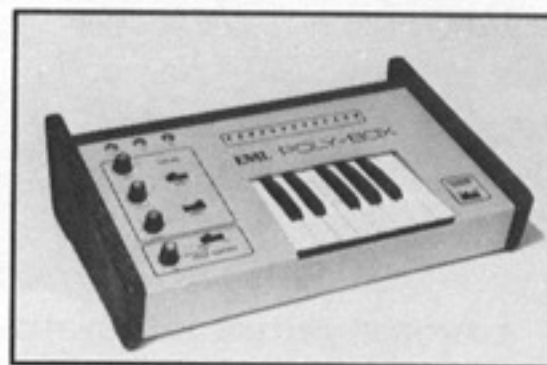

EML's Poly-Box creates 26 simultaneously available pitches from a synthesizer input.

Also from EML is *Electronmusic: A Manual For Composers*, by Robert A. Devoe. The manual is profusely illustrated by the author and covers a range of topics from acoustics to scoring electronic music. . . . .

A new magazine from the People's Computer Company called the *Computer Music Journal* will be available soon. The Journal will cover all areas of computer synthesis and computer controlled analog synthesis. Subscriptions to the *Computer Music Journal* may be obtained for \$14 a year at 1010 Doyle St., Box E, Menlo Park, California 94025. . . . .

E-mu announces the release of the 460 Microprocessor Keyboard. A five octave keyboard programs the sixteen voice polyphonic system. Programmable parameters

include pitch, duration and keyboard glide. The entire system is controlled by a calculator type keyboard. . .

Microprocessor technology is now available for all instruments with the *Compu-Sound Digital Filtering Device* by Frogg. It is capable of producing 99 different filter configurations at the touch of a button. All functions can be monitored on a large l.e.d. display. . . . .

Tangerine Dream will be touring the U.S. starting March 29. Laser Images Inc., the originators of *Laserium*, will be performing their laser images in conjunction with Tangerine Dream. The laserist will be Richard Vansenbrockworth.

The tour, organized by Virgin Records, will feature Tangerine Dream performing previously unreleased music and laser images performed live and projected on a rear projection screen suspended behind the group. While Laser Images' one watt krypton gas laser is used, the room will be darkened to achieve the effect of imagery floating in mid air. . . . .

Polyfusion has released *Sound-A-Round*, a joy stick or VCO controlled quad panner with one to four audio inputs. Included are four LED's to indicate placement, speed and direction. *Sound-A-Round* can be used with stereo and quad P.A. and playback systems and will drive any power amplifier directly. . . . .



The computer controlled, polyphonic DCS-1 from Strider Systems.



New from EMS is the EMS Vocoder. It accepts a speech input which is analyzed by a

bank of 22 band pass filters and sent to a patchboard that feeds into 22 synthesizing fil-

ters. Featured is an "Excitation" input which will accept any audio input which will in turn adapt the characteristics of the speech input. Also included in the Vocoder are 2 VCO's, a noise source, a pitch extractor, a voiced/unvoiced detector, a frequency shifter and a sequencer input. Demo tapes are available from EMS, London, England and EMSA, Amherst, Massachusetts. . . .

(Energy Bow) will sustain any steel string indefinitely with total control over attack, sustain and decay without any distortion, allowing further possibilities for guitar and synthesizer interface. The E BOW is available from Heet Sound Products. . . . .



The Vocoder from EMS London.

Utopia in Tokyo. Todd Rundgren and Roger Powell of Utopia, while in Japan touring to support the release of "RA," were invited by Isao Tomita to visit his studio in recognition of Utopia's involvement in electronic music. . . . .

New for progressive guitarists is a hand held string sustainer that works on an electromagnetic principle. The E BOW



The E Bow string sustaining device.

Please refer to the listings on page forty for any address not found above. . . . .

**FULLY MODULAR STUDIO SYNTHESIZERS**

*Available as complete systems, in custom configurations, or as individual modules.*

*Available in kit form with complete documentation and instructions, or as factory assembled and tested units.*

*Compatible with most other synthesizers available today.*

*Write or call today for a copy of our free catalog.*

**ARIES MUSIC inc.**  
**po box 3065**  
**salem, ma. 01970**

**(617)-744-2400**







David Bowie: Low  
RCA CPL1-2030

Always known for the sensational, Mr. Bowie's latest has evoked much negative reaction from music critics and fans as well. "Low" is a move in the musical direction of the "English Art Rockers", such as the Soft Machine, Gong, Michael Oldfield, and most notably, Brian Eno with whom Bowie collaborates on this album.

Side One is comprised of seven songs with titles like, "Always Crashing in the Same Car" and "Be My Wife"; there are a few interesting moments here and there, but the side is mostly boring as seems intended by the lyrical and musical posturing. These pieces are incomplete thoughts, overtaken by a lack of interest on the part of the creator. Sonically, most of this side sounds like Eno's "Another Green World", and occasionally like old Mothers. The drums played by Dennis Davis, sound rather surrealistic because of the noise gates they were recorded with. The result of these noise gates is that the ambience of the drums, distorted to begin with disappears shortly after each beat; very jagged formations.

Actually, I believe that this record makes more sense from a conceptual point of view after watching Bowie's film debut, "The Man Who Fell to Earth" in which he plays an alien who gets caught up in the boredom and decadence of American society. The promotional photo of Bowie for the film is also the cover of "Low".

Side Two is another story. The opener, "Warszawa" (War's over?) contains elements of Gregorian Chant and that Moody Blues/King Crimson "death of the universe" sound created by playing slow passages in a minor key on a Mellotron (actually a Chamberlin in this case but the

two devices are very similar). There are no drums on side two. The ambience instead is that of Fripp and Eno's collaborations or quiet sections of Synergy or Vangelis; very "low". The titles of the other pieces on the side might give one an associative impression of the mood here: "Art Decade" (-ent?), "Weeping Wall", "Subterraneans". "Subterraneans" consists of a slow ascending minor bass figure, ARP String Ensemble, a guitar with a lot of slow tremolo, wailing voices, and sax; all playing meandering melodic lines. It's very moving; it reminds me of Beaver & Krause's "In a Wild Sanctuary" from their first album of the same name.

Bowie has been hinting about this direction for some time. If one can accept this record as another part of a complex personality, there is much to be appreciated here; even if ya can't dance to it!

—Danny Sofer

"Dream Weaver". Whereas Wright played all the keyboards on that disc himself, "Light of Smiles" finds him assisted by members of his touring band, which may account for the added fullness of sound. Although he fudges a bit on his "all keyboard" number by employing real strings on a couple of tracks, in the main it is synthesizers, especially the Oberheim Polyphonic, that serve to play the parts that would be taken by string and brass sections on any other pop album. Wright himself plays the solos and engineers the effects on both Moog and Oberheim instruments.

The progressive stance of the instrumentation and production of "Light of Smiles" is beyond question. The stance of the songs themselves are another matter. While his unique approach has garnered some FM airplay for "Light of Smiles", it is apparent that, as with "Dream Weaver",



Joan La Barbara:  
Voice is the Original Instrument  
Wizard RVW 2266

Joan La Barbara makes great sounds on this live recording and all she uses is her voice, a phase shifter, pitch modulator, and an echo unit. Modulated timbres, several notes at once, subharmonics, filtering with various amounts of resonance are all done with her voice.

There are three pieces on this disc, all recorded at Berkeley's University Art Museum a year ago. The first, "Circular Song" is based on the technique of circular breathing, resulting in more or less continual sound, rising and falling, panting faster and faster, until climaxing in some modulated groans, then slowing back to the beginning.

"One-Note Internal Resonance Investigation" consists of one pitch sung repeatedly in different timbres, using the resonances of the head as a low pass filter, and the rest of the body as a subharmonic generator. (And you thought Captain Beefheart had an unusual voice?).

"Vocal Extensions" uses all of the above effects, plus more percussive and explosive sounds in conjunction with the echo unit and other electronics. Ms. La Barbara is very good at accompanying herself with echo and manipulating the controls of the Roland Space Echo as well as her voice to change the texture rapidly from one moment to the next. Her squeals and echo clicks are particularly effective to me as well as when she changes the echo speed, causing a momentary speeding up or slowing down of pitch. (I can't wait to hear her through an Eventide Harmonizer!).

Musically, some of the material is haunting, some evoking feelings of loneliness, some erotic, some cold and mechanical. But for me this record's appeal is

# DISC LA



Gary Wright  
Light of Smiles  
Warner Bros BS 291

Like his previous disc, the double platinum "Dream Weaver", Gary Wright's latest album "Light of Smiles" features an all keyboard approach that emphasizes synthesizers and synthesized arrangements. However, in most other respects "Light of Smiles" is gratifyingly superior to its predecessor. The production, for one, is more assured. Extensive overdubbing and a greater variety of instruments give "Light of Smiles" a more svelte texture than the clanky

this disc is targeted for the Top 40 market. In common with almost all AM tunes, the lyrics on "Light of Smiles" are frankly stupid, displaying little more literacy than those of KC and the Sunshine Band. Take for example the chorus to "Empty Inside":

I was so empty inside  
I was so empty inside  
I was so empty inside  
Till you came into my life  
(copyright High Wave Music)

Often the music is little better, as on the crude and insincere rocker "Silent Fury". However, a few excellent tunes show that Wright may be merely succumbing to commercial temptation and is capable of a better product. "Who Am I", the short but bizarre "I Am the Sky" (which sounds like Weather Report, of all people), and in particular the outstanding final cut "Child of Light" excite hopes of greater things from Gary Wright on subsequent albums. These songs at least dispense with the banality that is undeniably present on so much of "Light of Smiles".

—Tom Davey



not so much for the music contained here, but more for the implications of the music and Ms. La Barbara's vocal techniques.

Available for \$5.00 from Wizard Records, 127 Greene St., New York, NY 10012.

—Danny Sofer



Animals, Pink Floyd  
Columbia X798

Those of you who read the back pages of Rolling Stone know that the 40 foot pig floating through the smoke stacks on the front cover got loose while waiting for its photo session, disrupting traffic at Heathrow Airport till one of its hoofs

exploded over Kent. (shucks, I wouldn't josh you).

Those of you who saw the 1975 "Wish You Were Here" tour know that most of the album consists of rewritten outtakes from the series. "Dogs" (originally titled "Gotta Be Crazy") and "Sheep" (originally "Raving and Drooling") were dropped from "Wish You Were Here"—partly because of the success of an English bootleg recorded at Wembley Stadium and partly because the shifting musical concept of "Wish . . ." made them incompatible with the rest of the album.

The original "Gotta Be Crazy" was a beautifully convoluted, breezy, jazzy rush of words about the "you got to appear to be easy to see through" British bourgeoisie. "Dogs" is in the same vein, but adapted to the concept of the album. The studio work shows through here. "Gotta Be Crazy" was sparse and manic while "Dogs" is more lilting—a little more fully realized. "Raving and Drooling" was another Floydian epic to insanity in the same league as "One of These Days" and "Care-

ful With That Ax Eugene." As "Sheep", its the high point of the album, a crazy roller-coaster boogie with clean, razor-sharp guitar and a relentless beat. Despite Roger Water's recent dip into Kinksian provincialism, he still write a horror story with the lurid precision of a brain surgeon.

"Sheep" is about the uprising of the meek and lowly against those they perceive as their enemies, in this case the Dogs. At the end of the album, the Dogs are dead. The Pigs, the ones who are behind the Dogs, are still in control, allowing the Sheep as much freedom as is convenient.

"Animals" suffers occasionally from a lack of dramatic distance. I like Water's social commentary. He's a mean man with a metaphor, but on this album, its hard to tell whether he's writing high political satire or low polemic. This problem is most glaring on "Pigs", where he slips off into a blathering Marxist tirade against "well-heeled big wheels". In an album that focusses so heavily on literary allusion and illusion, "Pigs" is

graceless and heavy handed. It's saved from disaster by a catchy-funky tune or two and the album's uniformly neat production, but beyond its values as a neat little rocker, it adds nothing to the album concept.

Viewed as an electronic pop album, this is probably the best thing they've done since "Meddle". The tape effects that were so cameo-like and gimmicky on "Dark Side of the Moon" and "Wish You Were Here" are subdued here, more integrated into the music. The dentist drill whine that envelopes Water's vocals on "Sheep" is the scariest thing they've tried since "Umma Gumma". The grating electric purr of the 23rd Psalm in the middle is hard to make out without the lyrics on the record jacket, but then Pink Floyd at their best always toss over the literal for the over all effect.

Pink Floyd may never be as subtle or just plain bizarre as they were in the good old days of Hyde Park and LSD, but they've regained their intellectual tension. And they're still the slyest fuckers who ever read George Orwell.

—Richard Wadholm

## Get Serious...with Contemporary Keyboard!

Serious keyboard players are reaching out. Combining electronic and acoustic instrument sounds. Augmenting traditional keyboards with new electronic gear.

And they're reading *Contemporary Keyboard*. To keep in touch with the artists exploring new musical forms. And the engineers who make the new music possible.

*Contemporary Keyboard* is the one magazine that covers all keyboard instruments. All keyboard playing. It's as broad, as varied as the keyboard field today. And as serious about music as today's serious keyboard players.



Each issue contains in-depth interviews with the top keyboard artists. Classical virtuosi like Vladimir Horowitz, Alexis Weissenberg, Charles Rosen, Anthony Newman. Jazz greats like Herbie Hancock, McCoy Tyner, Marian McPartland, Keith Jarrett. Rock stars like Edgar Winter, Rick Wakeman, Gregg Allman. As well as country and western, ragtime, dixieland and ethnic stylists of distinction.

Columnists include: David Burge, on contemporary piano . . . Leonard

your subscription, if at any time you decide you no longer want to receive CK.) Just complete the form below. And mail it today with your payment.

Feather, on jazz . . . Bob Moog, on synthesizer technology, Roger Powell, on synthesizer technique . . . Chick Corea, on electronic keyboards . . . Misha Dichter, on 18th and 19th Century piano . . . Bill Irwin, on pop organ . . . and more.

Enter an introductory subscription now. \$12 for 12 issues. (You're guaranteed a refund for the unfilled portion of



CONTEMPORARY  
KEYBOARD

Box 907-KO, Saratoga, CA 95070

YES! Enter a fully guaranteed, introductory subscription to  
CONTEMPORARY KEYBOARD in my name for:

1 year @ \$12  2 years @ \$24

NAME \_\_\_\_\_

ADDRESS \_\_\_\_\_

CITY \_\_\_\_\_ STATE \_\_\_\_\_ ZIP \_\_\_\_\_

(Prices good in U.S. Foreign rates on request. Payment must accompany order.)





is:

**Synthesizers:** EMSA distributes ARP, Moog and Oberheim instruments at low cost to customers everywhere, and is sole American source of the Synthi line from EMS of London.

**Services:** EMSA, the center for EMS Synthi service in America, repairs and reconditions synthesizers; guides musicians to the most suitable instruments for their needs; and keeps you in touch.

**Students:** EMSA teaches electronic music in a well equipped studio, sends lecturers to schools, creates filmstrips, and broadcasts a regular radio program.

**Studios:** EMSA designs, equips and maintains studios large and small for individuals and schools.

**Specials:** EMSA's prices are sensible and often spectacular. For example, right now (for a limited time) you can purchase an ARP Odyssey for only \$1,070.

... and first and foremost, EMSA is

**Sound:** EMSA is a league of composers who create music for radio, film and theatre, while maintaining rapport with composers around the world.

### EMSA is:

ELECTRONIC MUSIC STUDIOS OF AMERICA, INC.  
269 LOCUST STREET, NORTHAMPTON, MA. 01060

## Danny Sofer

*yes  
you  
at  
Laserium,  
too!*

# DSMUSIC

811 FRANKLIN ST.  
SANTA MONICA, CA.  
90403  
213/463-8772

# Buying Your First Synthesizer

by Alex Cima

The most important considerations in selecting a synthesizer are your musical interests, direction, and style. Who do you like? Chick Corea? Karlheinz Stockhausen? George Duke? Morton Subotnick? Rick Wakeman? Isao Tomita? Larry Fast? . . . ? No doubt many others could be mentioned as representing a particular style, or attitude toward the instrument.

For the sake of simplicity, one can think of these styles as either leaning towards an imitation of orchestral instruments (brass, strings, flute, . . .) where traditional notation works, or that favoring a more "avant garde", dissonant, unconventional use, where notation stretches the boundaries of copyright law. This is important because some instruments may easily bridge both "styles", while others function best in a more limited approach.

Synthesizers may be classified as pre-patched performance systems, where all connections are hard-wired at the factory, or modular systems using patchcords, pin matrix, or similar means of making connections at the performer's choice. Modular systems offer greater flexibility as the possible combi-

nations between their modules or sections are astronomical, yielding a wider variety of control and sounds than the pre-patched instruments.

The price of a synthesizer is in direct proportion to its complexity and number of modules available. There is rampant competition among manufacturers, a fact which should work well to your advantage. A good suggestion would be to invest in postcards and request their literature (see *Synapse* manufacturers listing); however, if you are not familiar with how synthesizers work, an additional suggestion would be to *learn before you buy* (again see listings for schools and check for any studios near you).

All synthesizers have at least one of each of the following: a voltage controlled oscillator (VCO) and noise generator for sound production; a low frequency oscillator (LFO) to control vibrato and slowly changing events; a voltage controlled filter (VCF) to change tonal color (timbre); a voltage controlled amplifier (VCA) and envelope generator to control loudness and intensity changes over time. Keyboards are the most common interface (that is, bridge between the performer and the knobs). Differences in price reflect the available number of these basic components, their

### PUBLIC ACCESS SYNTHESIZER STUDIO

## PUBLIC ACCESS: NEW YORK

by Phil Terr

With so many technological advances affecting musical expression these days, it is easy to overlook two important ingredients for a healthy creative environment. Not surprisingly, the two areas: accessibility of instruments and the interchange of ideas, are both human considerations. The Public Access Synthesizer Studio (PASS) has recently opened in New York City to help solve these problems.

PASS, a non-profit New York corporation, is structured to provide "cheap as possible" time rental of three CBS/Buchla Synthesizers, one hybrid EML, Electro-Comp system and some Serge modules. By the way, "cheap as possible" is \$3.00 an hour with block rates available. More important though, is that PASS offers a free form exchange of ideas without ties to any institutions. It opens the possibility for the unification of ideas and ideals as well as the establishment of a center that would be truly community responsive since it is the community itself that would motivate PASS' evolution and growth.

PASS seeks to expand the availability of information pertinent to electronic music through its taped library of compositions and various seminars. The seminars will cover many aspects of electronic music, including discussions with composers.

The philosophy of PASS also supports the design and construction of systems and modules by the users themselves and has schematics and a technician (once or twice a week) available to facilitate the process.

PASS plans to expand its potential through grants in order to provide more services to independent electronic musicians.

PASS is to be congratulated for providing New York with this service and for providing everyone with an example that I hope will manifest itself across the country.

PASS is located at 135 West Broadway, N.Y., N.Y. 10013, (212) 964-9891. ~~~



quality, and whether other modules used to create sound or change its character are present in the system (phase shifters, ring modulators, envelope followers, voltage processors, reverb . . .). Thus, prices may range from about \$500 to several thousands.

One alternative you may wish to consider is buying kits, a little work on your part will stretch your \$\$\$\$. In any case, avoid paying the "list" or suggested retail price as stores will often discount 20% or more. Many synthesizers are not even available through musical instrument stores, largely due to the system's increased cost, complexity, and the fact that salesmen have been less than diligent in learning the instruments.

The best studio will have good recording and monitoring facilities, and in my opinion, would consist of instruments by different manufacturers and designers, interfacing different brands is rarely a problem, and this way will maximize the strengths of the individual instrument while minimizing any shortcomings. Some instruments are clearly superior to others in achieving a certain sound quality or in voltage control technique. No one single manufacturer has everything one would like. You may very well find your music direction changing as you experiment and integrate old and new musical ideas, and then perhaps deeply appreciate how technology influences musical content . . . isn't that growth?

Some thoughts in summary:

1) Consider that sound generation is accomplished primarily through VCO's, so the more, the better, their waveforms ideally should include sine  $\sim$ , variable duty cycle pulse  $\square$ , variable slope sawtooth  $\nearrow$  to  $\searrow$ . VCF's should have low, band, and high pass capability.

2) The instrument should have the ability to process external sounds such as voice, acoustic instruments, other synthesizers, and tape recorder output.

3) Stereo outputs or better. However, pre-patched instruments usually have only one output.

4) An adequate warranty such as 1 year on parts and labor. Be sure that *all* labor fees are covered, in some cases the manufacturer may agree to pay a portion of the labor fees, which may range \$10 to \$20 an hour.

5) Learn before you buy. If you are not familiar with synthesizers take the time to learn at least some basic concepts in electronic music before you spend money. Keeping up on new technical developments is not only a good idea in general, but may actually prevent you from sinking \$ in an old design.

6) Although the keyboard is the major interface with the synthesizer several other means of controlling parameters like pitch, filtering, and loudness, are now available. For example, the guitar synthesizer and frequency follower built by 360 Systems, or the pitch to voltage converter by Electronic Music Studios, London, or the electronic valve instrument (EVI) by Steiner-Parker, the electric saxophone by Serge Systems, and a multitude of microprocessors.  $\sim$

# SERGE MODULAR MUSIC SYSTEMS

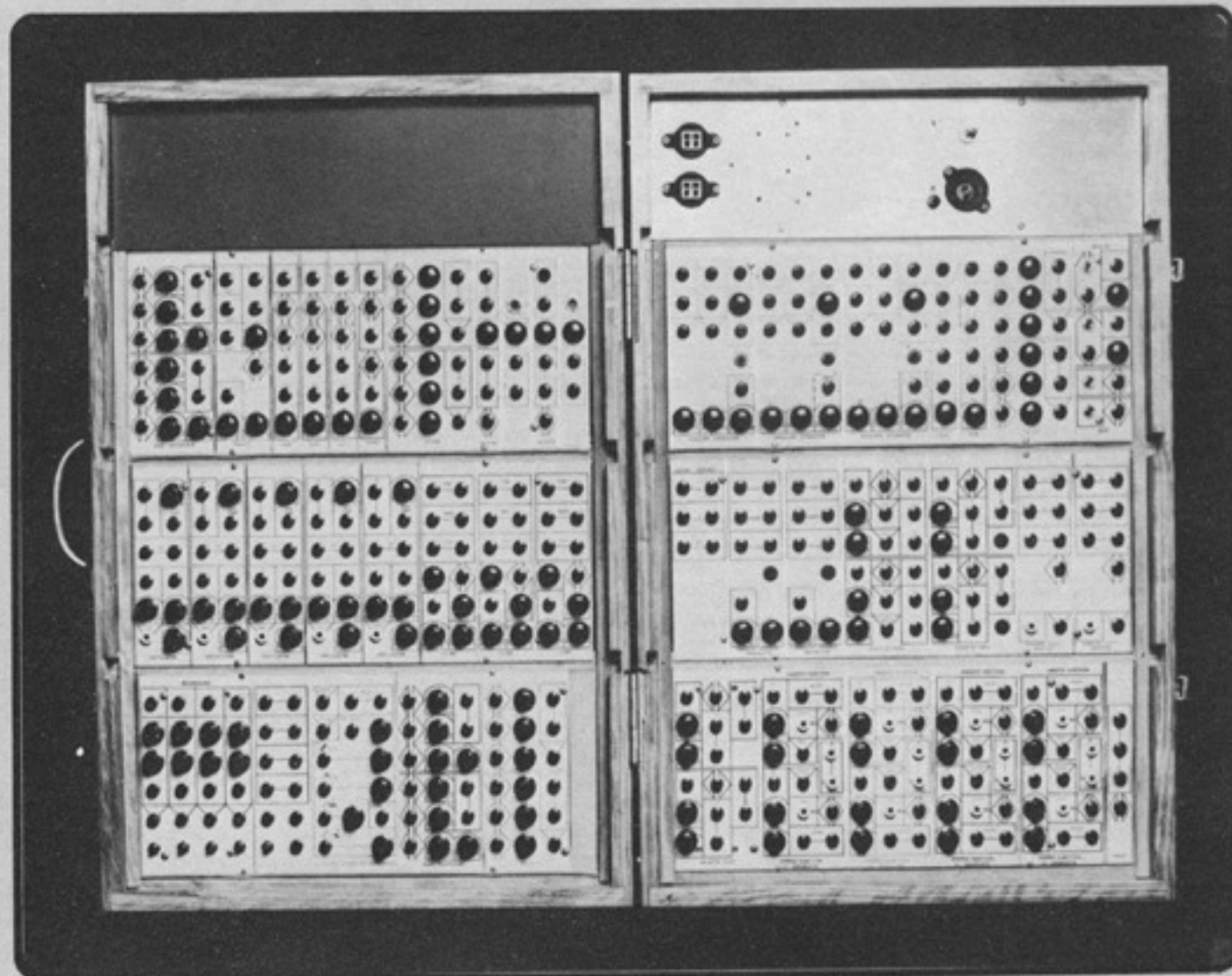

## THE AFFORDABLE STUDIO MUSIC SYNTHESIZER

*If you are shopping around for a synthesizer or thinking of expanding your present system with some new modules, be sure to check us out. We are SERGE MODULAR MUSIC and we manufacture the SERGE MODULAR MUSIC SYSTEM. Our systems represent the state of the art in voltage controlled equipment. Many of our modular functions are unique to the SERGE SYSTEM, and not available from any other source. Moreover, the SERGE SYSTEM is affordable. Module per module our systems cost from half to a third of the cost of comparable commercially available modular systems. Our systems cannot be bought at stores, we sell direct to musicians, commercial installations and schools. Furthermore, we can save you even more money if you buy our systems in kit form. (Note too that our kits are like no other kits. Most of our kit-modules are shipped complete with pre-assembled and tested P.C. boards, therefore ensuring that our modules will work for you right off the bat after you have finished wiring them up).*

*Send us a dollar for our newest catalog (refunded with your first purchase) or call 213-461-7987.*

*We think you will be pleasantly surprised about what SERGE MODULAR MUSIC can do for you.*

**SERGE MODULAR MUSIC**

Marketing Dept. G

1107 1/2 N. Western Ave., Hollywood, CA. 90029



---

# Los Angeles Center for ELECTRONIC MUSIC

---

by Phil Terr

Los Angeles has a new center devoted to the development of electronic music and related arts. LACEM provides recording and programming facilities for artists and producers, as well as several synthesizer seminars and workshops a year.

The musical services offered by LACEM include recording in a fully equipped 24 channel studio (Star track recording studios), the rental and programming of any number of synthesizers for both in house and other studios, and creative services such as composition, arranging, performance, instrument or voice processing, and special effect.

The center was initiated as a resource facility for electronic music, where synthesists' needs may find outlet and expression. At the heart of the idea is the dedication to develop a learning environment which enjoys superb recording and monitoring equipment, advanced modular systems, and instructors who are experienced performers and designers. At the present time the main educational activities involve the various seminars and workshops scheduled for late March and early June terms: a comprehensive 40 hour workshop where students first learn the rudiments of a performance synthesizer, beginning theory in voltage control and sound processing, then, through class and practice sessions, an introduction to modular systems with more voltage control and sound generation/processing capabilities. The goal is to achieve familiarity and technique regardless of the particular instrument used or musical style to which it may be applied; an advanced 18 hour workshop focusing on developing expertise in composition and programming using modular equipment, the core of this course is supervised activity in stacking and mixing control voltages, creating predictable and random complex patches, a finer appreciation of sound modifiers, and recording a class project.

Another course to begin in June is the polyphonic guitar synthesizer class taught in part by Bob Easton (360 Systems) and Lee Ritenour, guitarist. This class begins by presenting to students not familiar with synthesizers all the necessary concepts such as VCO's, VCF's, envelopes, and so on, then Bob will detail the workings of the guitar interface and 360 Systems synthesizer, where



PHOTOGRAPHS BY BILL MATTHIAS

all six strings can control their individual sound generation and processing modules, and then Lee will demonstrate his virtuoso technique.

Other seminars concentrate on short intensive training and practice on a particular system which the student would like to master (such as percussion synthesis). The center is equipped with two Synthi AKS, each one with a 16 by 16 pin matrix or "presto-patch" 32 pin connector method of patching, and a pitch to voltage converter, which changes the pitch of an instrument or voice into D.C. and "envelope" voltages that can control the pitch of an oscillator or any other voltage controlled module, the AKS and PVC are made by Electronic Music Studios (London); a Polyfusion series 2000 modular system with touch tuning of VCO's, formant filters, and pressure sensitive keyboard; three large Serge systems with over 14 panels of just about every module Serge builds, such as analog shift registers, comparators, sequencers and programmers . . . ; from Steiner-Parker, a Synthasystem modular unit which among other things has a frequency/trigger divider yielding transposable octaves and intervals from an input VCO or sound source, a Synthacon interfaceable pre-set, and an EVI, electronic valve

instrument or "trumpet" controller; a Star Instruments' Synare percussion synthesizer; and, the Strider Systems' microprocessor controlled synthesizer, a polyphonic analog system with significant sound generation/processing capability, all controlled by a hexadecimal keyboard and cassette storage of patches. All of these systems may be interfaced, some are keyboard oriented, some have a more elaborate V.C. setup . . . they provide experience with all patching methods: matrix, cord, pre-set, and digital.

The educational goals of the various workshops are to create and develop the necessary skills required to perform and compose with the analog synthesizer; to experiment with different systems, learning their limitations, potentials, and interface capabilities, thus offering a far richer and eclectic approach than working with only one system; to develop competence in basic tape recording techniques such as editing, echo, and all the "classical" studio elements; and to enhance awareness and appreciation for the myriad electronic styles and media.

LACEM is strongly committed to the production of electronic music concerts and events, such as the first Annual Los Angeles Electronic Music Festival, slated for September 1977. ~~~~



**THANK YOU  
FOR MAKING  
US THE  
NUMBER ONE  
ARP DEALER  
IN THE WORLD**



# Steve Hillage & Friends



PHOTOGRAPHS BY CHRIS AUGUST

**Phil Hodge, Steve Hillage, Basil Brooks and Miquette Giraudy** form the synthesis aspect of the Steve Hillage Band. Hillage's band, organized to perform music from his solo albums, "FISH RISING" and "L", is truly eclectic in that the terrestrial, rock 'n' roll grounded influence of the 60's and 70's represented by Phil Hodge (keyboards), Clive Bunker (drums), and Colin Bass (bass) is combined with the celestial contributions of Basil Brooks, Miquette Giraudy and Christian Boole, forming a time conscious but flowing music. The interface and synthesis of ideas, instruments, and sounds are central to his music.

Hillage likens music to liquid architecture; a sequence of events, shapes and colors evolving through time. In this context it is not difficult to understand his interest in the Great Pyramids and Stonehenge as vestiges of primordial power and knowledge. Hillage believes that the future of music lies in the potential of music as a healing force to be used for the advancement of all people.

by Doug Lynner

**Doug Lynner:** How did you become interested in synthesizers?

**Steve Hillage:** I am 25 years old and I have been playing guitar professionally for six years, and before that I was a philosophy student and I was into the concept of synthesis, the marriage of opposites, in an alchemical and Platonic sense. Since I was 14 I have played with wah wah and Fuzz and volumn pedal envelope shaping. In 1969 I got into echo, and in early 1972 I was invited

to play at ICES, an electronic music festival in London as my guitaring was considered "synthesizer-like." At the festival I met and played with Tim Blake who had E.M.S. equipment, and a few months later we were playing with Gong, a highly influential Anglo-French "psychedelic" band that had developed from Soft Machine. As I grew up in the middle sixties, so called "psychedelic" music was a great influence on me. The first live band I ever heard was Pink Floyd with Syd Barrett and the following week Jimi Hendrix, in late 1966. I was very much in love with some of the Beatles work at that

time—they were the first rock synthesists. I must confess I was more influenced by European psychedelic music then by American which often seemed rather superficial, although this is a particular quirk of my own.

Gong's music was itself a synthesis of electronics, jazz, rock, classical percussion, parapsychical humour, poetry, visuals, symbolism, and a form of electromusical mystical yoga. We were, I think, the first rock group to use lasers (1972) and both the albums "Angels Egg" (1973) and "You"



(1976) featured synthesizers strongly. David Allen, Gong's founder, devised and introduced me to a unique guitar sound called glissando which involved stroking the strings with a special metal rod, up and down the fretboard. All this time I was experimenting with elaborate pedals, echos, phasing, and interfacing with E.M.S. and Minimoog. I flashed on synthesizers first as producing hitherto unknown ethnic, tenuous, magical sounds and atmospheres, and later as producing full melodic material. While we were recording "You" I started work on "Fish Rising" which was a solo album consisting largely of material I had from before I joined Gong which the Gong experience helped me to complete. Gong as I knew and loved the band dissolved in 1975 and I left and met Todd Rundgren and Roger Powell, whom I rate very highly as synthesists, and with their help I made "L" in Spring 1976, which included some pitch to voltage guitar and a lot of Eventide Harmonizer. I now consider myself as much a synthesizer player as a guitarist.

**Basil Brooks:** I started out in school as Steve just said, with "psychedelic" music. That kindled my interest I suppose, in the first instance. I also have an Uncle who's a composer that's got a little electronic music studio. He got one of the first EMS machines. He showed me this machine and I was instantly amazed by it and wanted to get to know more about it. Finally I took an evening course in synthesizers. About then the money came to buy an AKS and I went from there with two other guys who played EMS equipment, and formed a group. The synthesizer band I was in was called "ZORCH" and was first formed in London in late 1973. We moved to the country in 1974 and were joined by two light synthesists who quickly became an equally important part of our live performance with their combinations of various projected images; something that I feel has yet to be explored to the fullest extent. We made three recordings during our existence. The first was done live in the open air, the second using Revoxes and the third using the EMS Synthi 100 and multi-track facilities. Part of this last recording was used as the sound track for a film called "Mother Earth" which was made using "Spectre" the EMS video synthesizer. ZORCH folded due to lack of funds and total commitment. However, the chances are it will reform sometime, probably for a free festival, these having been the high points of our performing history.

**Phil Hodge:** Well, I've only really been playing since I joined the band. Before that I never really worked with the synthesizer so everything I learned is from Basil and Steve.

**Steve:** The fact is, he's an excellent keyboard player. We consider synthesizers to apply to every instrument. Sound synthesis applies to everything. There certainly is a place for a keyboard player and a Minimoog which you have to have really good keyboard technique for. It's an important part of the keyboard mandala.

**Miquette Giraudy:** In '72 I began to live with "Gong" and there was this strange guy there named Jim Blake who was making some very amazing sounds. He had an EMS synthesizer. I don't know, it just fascinated me.

**Synapse:** *Did you play other instruments then?*

**Miquette:** No. I did some singing with "Gong" and then I met Steve and finally we got our ARP (2600) synthesizer. That's how it happened.

**Synapse:** *Given the history of contemporary guitar playing, there has always been the element of distortion, of clipping signals, of having the ability to sustain notes or not to sustain notes; making choices that are similar to synthesizers. I wonder if it may not be a more natural thing for guitar players to come to synthesizers than a keyboard player since they might be used to the acoustic sound of say, a grand piano?*

**Phil:** I think you're right.



**Steve Hillage**

**Steve:** I remain saying what I said before; I think synthesizers apply to everything. I'm really into the philosophical concept of synthesis.

**Phil:** Yes, but the thing of bending the notes is very un-keyboard like.

**Steve:** When I really grasped synthesizer it appeared to me that when you mix an album, you use Keepex, noise reduction, limiters, EQ, filtering, phasing, and very soon there will be pitch to voltage converters and envelope shapers as well as control filters all built into studio mixing desks. That's synthesizing as much as playing synthesizer. They go hand in hand. I get off on pure electronic music but at the same time I think all sounds fit together. The concept of synthesis of sound really appeals to me.

**Synapse:** *Do you think that there is any*

*aspect where the technology is writing the music as much as the composer? Do you think that technology is that influential on what is happening?*

**Steve:** I think it's all part of one big process that's happening. Making music out of technology is a beautiful thing. It's lovely. Making those little transistors sing is great. At the same time, when you get into that, you get into a concept of pure energy which in a way is the dawn of a completely new technology, which I think is going to come, when new energies will be discovered which are more subtle than electromagnetism.

**Synapse:** *Have you explored in the area of interfacing percussion and synthesizers?*

**Steve:** Well, not too much actually.

**Basil:** We did some stuff with a table player and the Hi-fly (EMS). The Hi-fly is designed for percussive instruments because it's attack sensitive. The Hi-fly tabla is very nice because it's got a beautiful filter section in it. Also, the "harmonized" bell sound.

**Steve:** The Harmonizer is great with percussion. While I was working on my last record with Todd Rundgren and Roger Powell, who I met after leaving the group "Gong," Roger Powell was making a solo record with all of the percussion done on synthesizer. It sounds just like a drum kit. It's interesting. Also, while I was having some speakers made, shaped like the pyramids, which we didn't bring to America because they're too bulky and cost a fortune, they were building a thing for Patrick Moraz with pads and a synthesizer with lots of noise generators. Rather like a Synare.

**Synapse:** *Who was constructing it?*

**Steve:** M&M Electronics, in Cambridge.

**Synapse:** *You said earlier, that the band's format is that of a basic rock 'n roll band with drums, bass, keyboards, and guitar, with the addition of a synthesizer section. What kind of concept is uniting these forces?*

**Steve:** Well, it's the concept of synthesis. It's a kind of celestial and terrestrial music. You have the rhythm section with keyboards, bass and drums which supplies the terrestrial side of the sound. It grounds it. The other side is the "airy" section with Miquette, Basil, and Christian who plays the glissando guitar. It's interesting, being sort of an astrology freak, I found that all the people in the rhythmic part of the group are earth signs and all the people in the celestial part of the group are air signs and I'm a fire and water. I'm in the middle kind of mixing it together because with the guitar, I play rhythmically, and yet I also spiral all over the place. The group is not necessarily a permanent group. We're all friends but we formed specifically for about a six month period to attempt to perform live the music from two records I made, *Fish Rising* and *L*.

**Synapse:** *Did you have this kind of band in mind when L was being made?*

**Steve:** I wasn't thinking of performing live when I was making *L*. When I heard the record back I thought it would be interesting to play live. Also if you can manage to perform your music live and do a lot of gigs,



# Steve Hillage & Co.

it does help to promote the record. It's a beneficial exercise although it takes a lot of organization and work. Finally I just released my control and thought, "Well, if I'm supposed to form a band, the band will materialize," and it did. We managed to put the band together very quickly after some preliminary investigation into some musicians.

**Synapse:** *How do you people from the "air" section relate to the music? How do you envision your input to the total sound?*

**Basil:** I always think of synthesizers in this situation as adding an extra aural dimension to the overall sound.

**Miquette:** Space.

**Basil:** The mix that happens on the board when we're doing a concert is very important because a sound that will come over as very subtle, just adding a little something; when it's not mixed right it can be vulgar if it's too loud, or muddy if it's too soft.

**Steve:** It's a really difficult balance. It's kind of like alchemy. It's never possible but it's an ever attractive thing to try and do. It's interesting, the concept of whether there ever is true silence in the physical world or not. A lot of people criticize this music saying that there are no holes, no density, which is true, it's nice to hear music that's very sparse but it's not necessarily any more real than music which is kind of total. As long as people get into it, it creates a total atmosphere over the whole ten octaves. Rhythmic music and arrhythmic music are like Yin and Yang. If you put them both together, potentially one can achieve a greater harmony which is more than the sum total of the notes played. A harmony of sound and feeling.

**Basil:** I think synthesizers can sort of emphasize the over all momentum of a piece of music.

**Steve:** We were doing a piece called Doorways; it's the old principal of a rhythmic mantra going on in one key. With the glissando guitar you can subtly change the inversions going over it in terms of 9th's and 11th's. It sounds like it's changing keys but it's not and then you can go and change keys as well. And it really makes it graceful, so we do these kind of epics with lots of chord changes in it. It's nice to use a synthesizer to make a kind of flowing sound as if you're going through a dimensional doorway each time you change a chord and you don't really hear it but it makes the music breathe a bit.

**Synapse:** *What kind of affect or impetus do you think using synthesizers in music will have?*

**Steve:** Well, I must be honest, there are a lot of bad synthesizer players around. It's a bad thing to say, but a lot of it sounds mickey-mouse. It's not used very well all the time. There are a lot of good synthesizer players; we seem to be bumping into a lot of them and that's great because I believe in the

idea of a synthesizer player's global cooperative. That's where it's at with synthesizers. It often gets a bit farcical when you get synthesizer players who choose to guard their patches. It's just not possible; synthesizer playing seems to be on a higher plane than that. Obviously, you'll have a positive and negative aspect to adding synthesizer but I'm into the positive aspect of it, so I tend to follow the ideas that appeal to me rather than looking around at what other people are doing.

**Synapse:** *What instruments would you like to see developed in the future?*

**Basil:** Well, things like the Vocoder (EMS). I've only used it twice. The first time we used it to simulate an extraterrestrial

done right. It would be a super mix. Everything would resonate in it's own frequency. I imagine a kind of glowing sound. The Vocoder would have to be updated a bit to do that. It would have to cover the full frequency range. It's almost there. It also works as a frequency spectrum analyzer. I'm an amateur frequency spectrum analyzer enthusiast. I want to get a battery operated, pocket sized one and walk around the street with it to see at what frequency things are happening.

**Basil:** The Vocoder also has it's own oscillator and pitch to voltage. It has a voiced and unvoiced detector to determine between vowel sounds and voice sounds. It's also got a slew on it which is quite



**Steve Hillage and Friends relaxing in the February sunshine of Los Angeles before resuming their tour in cold Kansas City.**

voice which in fact we did by inverting the speech. Basically it's (the Vocoder) got two inputs; a voice input, which is an analytical thing that splits the frequency spectrum up into 22 different frequency bandwidths that are proportional to the amplitude of those bands in the original voice. You get a "picture" of the input in real time. Then it goes into a patch board with which you can patch any analytical filter to control any of the other filters which correspond to the band width. Say, you can get the bottom frequencies of your voice to affect the top frequencies of the filter.

**Steve:** It's like an electric voice box. If you play a record or an instrument through it and speak into it, you interface them harmonically so you'll get the music speaking. Getting music to talk is a bit "party time,"—it's interesting but it's not the sum total of what you can do with the box. If you had it built into the mixing desk you could create some incredible effects. Unbelievable music. It would be so harmonious if it was

interesting. You take it so far and it will just slew the changes in filter point and pitch and you take it a bit further and it freezes the input. You can sing a note into it and it will just carry on.

**Steve:** I would like to see synthesizers reduced to chips the size of a matchbox where you wouldn't need any leads; just pure radio. Everything would be controlled by little pocket calculators with computer auto-patch.

**Basil:** The thing you have to be careful of is that when I've seen that kind of technology it seldom works. It's always breaking down.

**Steve:** Yeah, but you've got to start with these big, cumbersome things before you can get to a streamlined i.c. It would be great if you could have a computerized polyphonic synthesizer plus multi-instrument interface. I think the prices of synthesizers is a great pity but in a way it shows that there is a certain kind of spiritual karma attached to it. I know a few synthesizer players who feel very bitter because they can't get the money together for



the gear they want and I think very often they have to sort themselves out and get resigned to the situation, then maybe they'll get the gear they want. You can see synthesizers as a very decadent thing. Western man going over the top with this technology; a rich man's toy. I really don't want it to go that way at all. I think there is a great future in it as a beneficial source of musical inspiration.

**Synapse:** You spoke earlier of an electronic music cooperative. How would you see that working?

**Steve:** Lots of synthesizer players being friends with one another. Then take it from there.

**Synapse:** Were Todd Rundgren and Roger Powell influential in the way you used electronics on L?

**Steve:** Those guys are really first-class electronic musicians each in their own way. Just being around them I learned a great deal. It was a very illuminating experience. In many ways the record was a question of; I had all these ideas and sounds and I wanted them to help me get them on tape. I think Roger Powell is a great synthesizer player. He has a complete mastery of the instruments.

**Miquette:** His new record is very nice. It is a solo album.

**Steve:** Personally, I thought that side two of Todd's record *Initiation*, which got very bad press, was a very fine piece of synthesizer work.

**Synapse:** Who, to your thinking, are really good synthesists?

**Steve:** With my experience up to now, the people I admire the most are Tonto and the Expanding Headband. Particularly a thing called The Pyramid Suite on side two of *It's About Time*. I feel that's a wonderful piece of music. I think they're the people that influenced me the most.

**Basil:** Some older stuff that I particularly like is by a group called "White Noise", although it's not all electronic, it's still a very electronic album.

**Steve:** From a keyboard player's point of view, both Phil and myself are influenced by people like Jan Hammer and George Duke. They're in a category of their own. I think Joe Zawinul is a great synthesizer player.

**Synapse:** What affect has synthesizer playing had on you musically and personally?

**Miquette:** I don't know. For me it's the first instrument I can do something with. So I feel it's my instrument. I'm not a keyboard player, I'm not a guitar player. I just feel like it's a new instrument that can bring something to the other instruments that they don't know yet that they will know soon.

**Phil:** I find it kind of strange actually because keyboards are usually chordal instruments and a Minimoog is monophonic. Bending the notes I find quite strange; it's very much like a guitar or trumpet. It's not really like a keyboard.

**Miquette:** It's like all the instruments in one.

**Steve:** Well, it's a "synthesizer".

**Synapse:** (to Basil) Do you use a keyboard with your set-up?

**Basil:** Well, I've got a touch keyboard. It's the AKS (EMS) keyboard. I program sequences of notes with it and then transpose the whole sequence using the same keyboard after it's been programmed. I also do rhythmic sequences which the band plays along with.

**Synapse:** At this time we have gotten to the point of being able to do very complicated synthesis but there is a lot of technology between the ideas and the sound. What do you think the future possibilities are? Do you think we can look forward to needing less equipment between the ideas and the music?

**Steve:** Like non-physical hearing?

**Synapse:** That would be a possibility; like telepathy.

**Steve:** Telepathic hearing. I think in a way, that that happens already. If you start communicating telepathically with music you don't need to play any more but obviously that doesn't happen. I think there will always be a need for the physical interface with music that makes it real.

**Miquette:** Yes, but I can see that people are getting more and more psychic and more and more transparent and they can hear more.

**Steve:** I don't see what would be wrong with it if that became more of an accepted

part of musicianship but I don't think it would be right to completely discount physical phenomenon of sound vibration. There is also kind of a weird scene because sound is very much a phenomenon of time. Cycles happen per second and if there were no seconds then you'd just have a continual uncertainty; it wouldn't be a wave. I think the greatest synthesis is bringing together all the various aspects of music in every way. Even a harmonious social structure, harmonious buildings and health all happen to go in one creative life style. That's my big idea in the sky. I think it's time to have a big research into the psychic aspect of music and the way it affects people and the way it could be used for healing and therapeutic purposes. I think that's going to be the new thing. It's going to become more and more esoteric. I find that when I listen to music, it's not just the trade of the artist but it's the feeling that he transmits through his music that I'm picking up and getting off on.

**Synapse:** What do you think the optimum medium for "healing" music is?

**Steve:** I would hesitate to say electronic music because it would blaspheme a lot of very, very beautiful classical music and acoustic music. But I do think the electric media is very powerful. It's a new type of energy. If that kind of power is used with the intent of raising people, it's a kind of added donation. ~~~~



**ELECTRONIC MUSIC:  
IN-HOUSE PRODUCTION  
SCORING/ARRANGING  
RECORDING • RENTAL  
SALES • CONSULTATION  
INSTRUCTION • 2825  
HYANS ST. LOS ANGELES  
90026 • (213) 487-5148**

Sound Arts



# Synthesizers on the Eco-Front

In April, 1975, Will Jackson, author, musician, and inter-species communication researcher, committed his various abilities to the task of preventing the extinction of our planet's largest mammal, the whale.

The GREENPEACE FOUNDATION outfitted an 80 ft. halibut boat christened GREENPEACE V and sent it to disrupt the commercial activities of the Russian whaling fleet. The strategy was to lead the whales away from slaughter. The method was sound communication in the whale's native environment, the ocean. In his role as "communications expert" (or in his own words, "synthesizer operator/musician") Jackson broadcast sounds into the ocean and found the whales to be a curious and imposing audience. The sheer power of the experience is best described in his own words, "... having these gigantic creatures surface repeatedly within twenty feet as I played random sounds against the rubber and wood bottom of the Zodiac inflatable, I realized that there could be no limit to the concept of ... communication ..."

by Will Jackson

On April 27, 1975, I stepped from among a crowd of nearly 20,000 whale well-wishers and boarded an 80 ft. halibut boat converted into an eco-protest vessel christened Greenpeace V—a beautiful, sunny day filled with music, art, dancing, sharing of hopes and dreams, and declarations of love and conviction in righting environmental wrongs. The object of this conviction was the whale itself, a member of the cetacean family of sea mammals fifty million years old. Evolving from an unknown land animal (some believe it was the shrew) long before the earliest recorded human mammal, this mightiest of all earth's creatures returned to the marine environment to utilize its unique biological "tools" more efficiently. Apparent-



SIREN SONG FOR WHALES is played on electronic synthesizer set up on deck of Greenpeace V by Will Jackson. But unlike the sirens of myth, Jackson is calling the whales not to destruction, but to

safety, away from harpoons of Russian and Japanese hunters. The Greenpeace V and Greenpeace VI left Winter Harbor early Tuesday to begin attempt to disrupt North Pacific whale hunting.

ly, such were the demands of reality at the time. But it may be argued that the choice was entirely voluntary, the environmental qualities and advantages of the ocean possibly being greater than the terrestrial. Humanity's ego finds this hard to accept, but one would not know it by observing the species' overt abuse and rapacious exploitation of its chosen home; and not confined in its malevolence to this, technology was developed to permit man's re-entry also to the sea.

(I say "man's" in this instance, because sea exploration and travel was by nearly all surviving accounts the world of men alone.

Without delving too deeply initially, as this point will be examined again in context, it seems reasonable to say that a system as lopsided as this could conceivably be responsible for a major portion of the embarrassing and regrettable precedents set in early history's oceanic "conquests").

But this voyage was said to be a different kind of precedent—a new age precedent, wherein all the values and aspirations of the new age would come together to deal the mighty corporate dragon a fatal blow, and reclaim the lost world "in the name of righteousness". As a grassroots campaign, the idea



of sending ships to save the world's whales was brilliant and simplistic, relying on any and all available resources and "guises" to achieve its end. Everything—every political, cultural, technological and scientific angle—was sought to be used as a ploy to manipulate emotions in favor of ecological and environmental redress. And each person taking part in the voyage had to up front agree to being exploited to whatever degree in the service of whale-saving; this included one's work, name, reputation, tools, and even one's life if need be. For some, the commitment was based on a personal belief not unlike that of a religion. For others, it proved to be ecologically—and politically—expedient. As voyage coordinator, Bob Hunter, put it, "This is a media skirmish in which environmentalists drop 'mind-bombs' in the laps of the public, creating a moral crisis the resolution to which is obvious. If the abuses we cite are not soon tended to, there will be more than planetary ecological catastrophe to deal with, there will be violent eco-revolutions and insurrections to throw any last semblance of civilization into terminal chaos. Although personally I wish to follow the teachings of the Buddha, I

**Bob Hunter: "This is a media skirmish in which environmentalists drop 'mind-bombs' in the laps of the public."**

find myself involved in a 'media war', playing with biological dynamite. The Buddha, however, does not condemn war in all cases, and neither does the I Ching, which, by the way, gave the expedition a launch-time reading of 'The Creative'."

Seeing the analogy of this venture to the anti-war movement of the Sixties yet in the same instance seeing it going against the psychological grain of anti-war sentiment, I boarded with a conscience leaning toward positive communication with both the whales and the whalers, leading to a clarification of the terms "interdependence" and "interrelatedness" within the context of the whole earth as a spaceship community. Aware of the possible compromises ahead, I accepted the job of "communications expert", an overblown misnomer for synthesizer operator/musician initiating efforts to establish "communication" with the whales of the North-eastern Pacific.

"Nobody has ever gone out to where the whales are and tried to get in touch with them in their environment", said Hunter in the Seattle Post-Intelligencer. "The key is apparently music, which is like whale speech."

"The mother ship Greenpeace V will beam live music to whales in the water—We've worked out a special system to do this. By beaming sound we can hopefully attract whales to the boat, and protect them from the whalers." Hunter went on to say that certain

musical celebrities would be brought aboard to take part in the experiments; all part of the media exploitation strategy. Such notables as Joan Baez, Crosby and Nash, Paul Horn, Joni Mitchell, Gordon Lightfoot, Paul Winter, and even Allen Ginsberg were mentioned; none of them confirmed, but hopefuls all. It was even reported that Dr. John C. Lilly would join the ship as technical advisor. As it turned out, only two of these individuals actually took

not higher—created an intense feedback loop within the artificial community that was the GP-5. A subskirmish of semantics and language was engaged bringing out the best and the worst, the deeper beliefs and motives, in each of us. Where most movements would agree to minimize attention focused on the relationships and lifestyles, and patterns of behavior, present within the active group, GP-5, precisely because of the wholistic

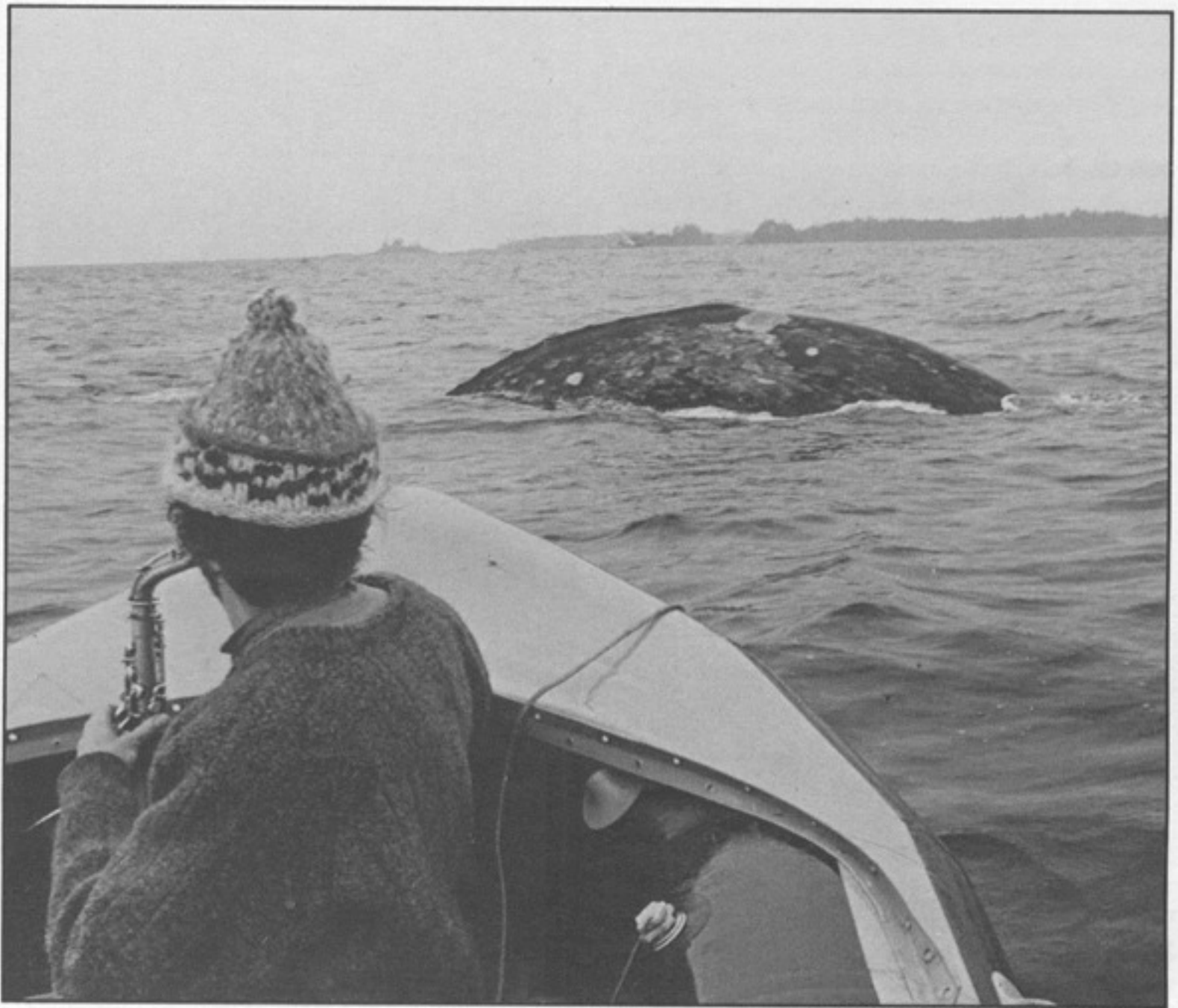

PHOTOGRAPHS BY REX WEYLER

**Paul Winter performing before a large audience. The object that looks like a rock is a Grey whale.**

part: Paul Winter and Paul Horn, both relatively "non-commercially oriented" and deeply involved with ecological and endangered species concepts in their music.

Paul Winter boarded as we sailed out to meet our first group of whales, two weeks into the expedition. Spending several days with ten gray whales off the coast of Vancouver Island, we piped synthesizer and saxophone sounds together through the (cut-rate) underwater speakers and attempted to record responses through (homemade) hydrophones. Gray whales being among the least vocal of all cetaceans, and given that our auxilliary engine necessary for the generation of AC power sent out a constant noise signal through the highly resonant wooden hull, we did not succeed in our primary ambitions. But a new awareness of whale/human consciousness and relationship began to appear, oft times running parallel yet counter to the "militaristic" strategies and the minds which formulated them. The mere presence of whales-beings believed, some say quixotically, to be of the IQ levels of humankind, if

nature of its ideological posture, proved to be a "control experiment" in itself; a mini-test case for the quick evolution of the human consciousness and its grasp on language concepts. We were caught in the myth-making machinery of the world media game, bearing jewels of new age awareness while wielding monkey-wrenches of 20th century karma. The myth had to be dismantled as it was being constructed, lest the act become

**the idea of sending ships to save the world's whales was brilliant and simplistic**

just another tooth in the juggernaut flywheel of Manifest Destiny. Common understanding—clarification of facts and fantasies—was the key to the cause of saving the whales. And the choice of language would determine our access to that key.



## Music and Cetacean Language

**W**here does the music enter into this? Simply that music is language; not a passive one, but a vital one that crosses all barriers of culture, experience, thought and action. We need not be reminded in the old cliché that it is "universal". But we often overlook the fact that it is specific, personal, capable of tapping the emotions of all forms living or so-called inert. Music is vibrations, not styles, ultimately. And there are forms of language that are free from styles and cultural context. Being long involved in audio spaces which have yet to be given adequate labels, but which cannot be denied for their compelling form and energy—some refer to it as electronic, or avant garde, or simply new—I understood the communicative force of the intuitions and emotions inherent in sound. And that this force was related to yet independent of, word forms and verbal patterns; and I suspected this to be a factor in mis-communication between people. Ready access to emotions could not seem to be had through verbal process, unless, like in song, primary attention is given to the tone and "feeling" of the utterance.

Gregory Bateson, in his book, *Steps to an Ecology of Mind*, puts forth some very specific insights evolved from his work in the fields of schizophrenia and inter-species communication:

We do not know what a primitive digital system for discussion of patterns and relationships might look like, but we can guess that it would not look like a "thing" language. It might more probably resemble music."

"I would want to know something like, 'If it be so that human language with its identification of things and purposes leads to an epistemology in which the sensible thing is to eat the environment—and eat up the environment—then how do dolphins structure their universe?'"

## Music is language; not a passive one, but a vital one that crosses all barriers of culture, experience, thought and action.

In *Mind in the Waters* (Joan McIntyre, Project Jonah) he is quoted as implying that for us to fully comprehend, it would mean "giving up having hands, giving up naming objects. Porpoises don't have hands, how lucky they are! What they have we hardly know . . . we are awfully anthropomorphic people."

Anthropomorphic or not, after spending several hours with "wild" whales, drifting solo with nothing but a cassette recorder and a penny-whistle, and having these gigantic creatures surface repeatedly within twenty

feet as I played random sounds against the rubber and wood bottom of the Zodiac inflatable, I realized that there could be no limit to the concept of inter-species music—or communication—as it includes all aspects of consciousness; not the least important of which being the area we pedantically call extra-sensory perception.



## An illegal under-sized Sperm whale being pulled in by a Russian whaling vessel.

Electronics, as toyed with by humanity, may be a recent development; and the external application of it in language forms and formation is evolving our minds and relationships very rapidly, nearly too rapidly for us to comprehend. But we find that our brain and nervous system, our total being, gives off electrical impulses, programming and deprogramming our experiences and collective images. A state of electricity exists in every conceivable element and form. Yet we appear surprised, or even alienated, by recent developments in electrical manipulations such as applied to the fine art of music. As time goes by, and new ways are discovered of perceiving the audio relationships of our world, we as everyday people, consumers and workers, will realize that electronic music is not "alien" or "weird" or "esoteric", at all. It is the sound of our very bodies and thoughts. But I expect it will take our becoming cognitive of the synchronous audio interplay of our entire biosphere; from the "dance" of the DNA to the song of the vociferous whale to the great quasars shifting at seven times the speed of light. However efficient and sophisticated our systems become, we as walking, breathing, swimming bioplasms will continue to ponder our relationship and purpose in the universe.

And the lowly musician, the electronics weirdo, the video-eye of the eccentric mind exploring color and light and texture, does not play a fool's role in this process. As Rasa Gustaitis put it in an SF City magazine article on inter-species communication, "It appears that the sonorities of the life force are now being recognized beyond the realm of mystics. Scientists and others are learning that each living thing, as a part of its living, emits sounds or vibrations. Some musicians are tuning in to the sounds of other species and creating something new . . ."

She goes on to quote Dr. Lewis Thomas in "LIVES OF A CELL":

"If we could listen to them all at once, fully orchestrated, in their immense ensemble, we might become aware of the counterpoint, the balance of tones and timbres and harmonics, the sonorities."

Experiments in inter-species music take the researcher into realms of discovery far beyond the planned objectives of the "control" experiment. Like in nuclear physics and cybernetics, one is inevitably brought to the question of life and purpose; of nature's power and intent.

## Of Human Bondage

**W**e must look at more than the musical experiment—the subject and the systems used. We must continually seek the overview, the expansive "meta" relationships between, to evolve beyond the dogma of our patterning. Though it is most threatening and painful for us of well-developed defenses, we must examine the ego and its workings as part and parcel of the experiment. When the ego builds up barriers and separations, an imbalance is created, and our effort is tainted by a certain amount of traumatized or otherwise unavailable space. The imbalance sets up a radical oscillation which tends toward polarization and duality; our experiment is complete only on two planes, and we have no way of perceiving the myriad other possibilities.

One example could be our preoccupation with the notion that there are two sexes. Recently, innovative research has produced indications that there exist in humans alone as many as sixteen sexes, each with its own biogenetic code of behavior. If information of this nature had been admitted into the world of our ancestors, perhaps those first exploratory voyages, for example, would have produced much more wholistic results. If the voyage of the Greenpeace V had been structured with a sensitivity to wholistic systems, which is the basis of new age thinking, a greater degree of success might have been realized, both in communicating with the whales and in terminating the commercial slaughter of the species. It has been implied by many that whales respond to female humans more readily than to males (it is yet unknown if they discern all the other sexes as well). Could this be accredited to that certain something superstitiously termed "women's intuition"? Questions such as this only begin





## Greenpeace musician Don "Iron Buffalo" Franks plays to "Killer" whales, later learned to be making love.

to scratch the surface in human/cetacean exchange.

"From what is known", says John Sutphen in *MIND IN THE WATERS*, "about the resolving capabilities of the dolphin's sonar and from certain well-established principles of physiologic morphology of internal organs and tissues, it is reasonable to assume the cetaceans are aware of each other's health and well-being . . .

"What sort of candor might exist between individuals where feelings are instantly bared? . . . Perhaps dolphins pick up similar vibrations from us."

I met a man aboard the Greenpeace V who have turned his back on a flowering career in Broadway and TV to be close to the earth—the truth of his existence. With his beautiful wife and daughter, he went to Saskatchewan and joined a tribe of Cree Indians, and became a teacher, a builder, a father, a brother, a music maker, a spiritual counsel.

When he stood on the bow and chanted into the setting sun as dolphins rode our bow wave, I knew there was a deeper meaning and reason for our work. The reason why I can no longer live isolated within one system.

"If you would recognize that you are a part of everything—that you're not the master—that when the words from one of the holy books said 'I give you *dominion*' over all this,

it meant that you are possibly a little bit of a janitor, and a little bit of a lover—and have an understanding that you are part of all this great mystery. Because with all the things that can come to your way, pretty soon you suddenly say, 'I really don't know very much about anything'.

### I watched the harpooned whale roll over and over in the sunset . . . . .

"As Sitting Bull said, 'Let us put our minds together and see what life we will make for our children'. Otherwise, it would probably be a lot easier for the people that are in this room to open up a pizza stand. A lot easier than to save the planet!"

As we sent our musical message across to the people aboard the Russian factory whaling ship, Vostok, I thought of this man, Don Francks, better known to me as Iron Buffalo. He saw through our eyes the black smoke belching from the hammer-and-sickle stacks and the bodies of Sperm whales of all ages being drawn up the slipway through the stern

of this floating city. His spirit was right there in the Zodiac raft when a Russian harpoon missed it by fifteen feet and exploded in the side of a female Sperm whale. I listened to a tape of his chanting as I watched the harpooned whale roll over and over in the sunset, finally coming to a dead stillness in crimson waters. There were simply no words for that moment.

Nor is there an adequate description—outside of the music itself—for the times playing with Paul Winter as families of gray whales surfaced all around us; or when two Orcas ("killer" whales) made love by our boat to the accompaniment of "whale sounds" played live on the Tcherepnin synthesizer and piped underwater.

My life and my music have been affected deeply by these experiences, and I realize there is no turning back on what I have seen to be a truth of existence in this world. No external system I would create could replace or otherwise substitute for the life that is created from within. I ponder the manipulations and machinations of humanity, and decide that I must reject their use for ways that do not further consciousness.

A being that is free is worth any number of beings that are not. For me, this is the purpose of music and consciousness—discovering languages that create freedom. ~~~~



**T**odd Rundgren and Roger Powell are well known as synthesists, producers and recording artists, throughout the music industry. Unlike many "popular" recording artists, their use of synthesizers as well as recording studio accessories, does not end with "clichéd" effects. On the contrary, both have extensive experience with technology, allowing a wide creative framework.

At the time of this interview, Todd Rundgren, Roger Powell, Kasim Sultan and John Wilcox, all members of Utopia, were less than a week and a half from the start of a sixty day national tour to support the American release of "Ra", the group's latest L.P.

The performance is highly theatrical and includes a thirty minute video tape (made by Rundgren in his video synthesis studio), a fourteen foot gold sphinx with a laser in its third eye, a twenty-four foot pyramid, fountains and flame throwers.

Of special interest is Roger Powell's "Probe Keyboard System". The Probe is a plexiglass, keyboard controller. It is designed to be "worn" like a guitar and controls an off stage six voice polyphonic synthesizer. With such a system, the performer is freed to interact spontaneously with the audience.

by Carter Thomas

**Carter Thomas:** How did you first become interested in the possibilities of electronic music?

**Todd Rundgren:** I became interested before I became a professional musician. What was called "electronic music", didn't have a lot of synthesizer, it was mostly music concrete, tape manipulation and editing.

**Synapse:** Which composers did you listen to? Stockhausen?

**Todd:** Oddly enough, no. I used to listen to these collections on Turnabout Records and things like that. I didn't have any money so I never bought anything that wasn't in a

# Roger Powell & Todd

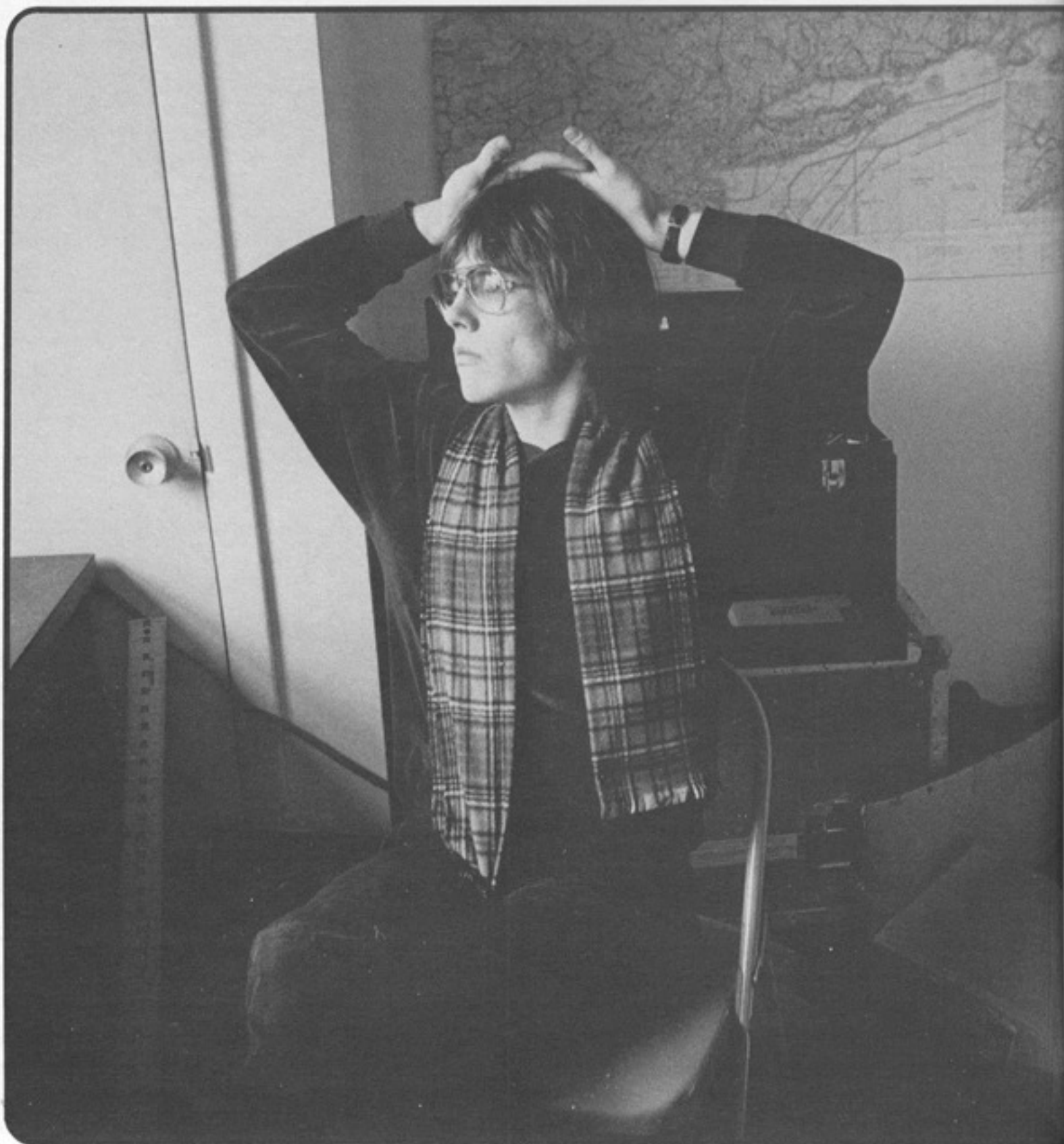

Roger Powell

bargain bin to start with and these things cost about \$1.99.

**Synapse:** Did this influence what you think about electronic music now?

**Todd:** Yeah, it did. I don't think in strict terms . . . I think in more broad terms, which is why some people consider what I do to be "excessive," because it doesn't resemble strict musical measures, and stuff like that. It harkens back to that more liberated approach to making electronic music.

**Synapse:** Can you think of your music more as timbral and textural music?

**Todd:** In some ways, yeah. In some ways it is to stimulate certain aural senses and hopefully to insight the listener to higher forms of imagery. In other words, most of the music that people listen to has sort of a pedestrian imagery that goes with it and electronic music to me has a more . . . some people call it psychedelic, but to me it's a more abstract, less materialistic imagery that goes along with it.

**Roger Powell:** Well, I got exposed to it

about the same time. When I was growing up in the 50's, my parents started me on piano lessons and I got interested in avant-garde music and that of course led to various electronic compositions. I was listening to the same people, Henry and Ussachevsky and some of the really early computer music experiments. I was really into it more cerebrally, but most of it once I heard it it left me cold. I felt it was still pretty much the domain of the technicians and the engineers and it didn't seem to me that there were many human musical elements interposed in it. Then, of course, Walter Carlos came out with his famous album. I thought, well here's a small ray of hope. Someone has at least taken music that can be recognized to help bridge this gap between what has gone before and this new wave of electronic music. But then again, I still felt that it was kind of a pointless exercise because the instruments do speak for themselves, and they can create timbres of their own.

**Synapse:** Can you tell me about some of



# Rundgren



PHOTOGRAPHS BY EVE KESSLER

the technology and electronics that you're using in the staging of your show that you're putting together here tonight?

**Roger:** Well, the most exciting thing in my life at the moment is the arrival of the new polyphonic synthesizer that I'm playing which has been dubbed the "probe keyboard system," and that manifests itself in six synthesizers which are located off the stage and they are remotely controlled via a thin, flexible cable which is connected to a fiberglass enclosed keyboard. And on this keyboard are mounted various potentiometers and switches which allow rather sophisticated control of the six synthesizer modules which are off the stage. So this is one thing that we've got with us now and there are some new guitar synthesizer boxes happening over in Todd's department.

**Synapse:** Can you tell me a little bit about those?

**Todd:** We have a custom built system using E-mu modules and I am also using some

Eventide equipment, like a harmonizer, and flanger. I've been controlling the harmonizers with a foot pedal that will give you a two octave range, up or down an octave. In other words I don't use hardly anything conventional except for an echo box. I don't use any of the conventional guitar player effects, like a wah-wah pedal or a voice box. The guitar is being processed on almost a studio level.

**Roger:** Both lead instruments have pretty much what you would want to have if you were recording them in a studio. There are certain processing devices which you would automatically use if you were recording. There's no reason to deprive yourself of that sound while you're on the stage. You know, you get used to a certain sound and that's your sound and these things are really just extensions of your instrument, they're not like extra pieces of gear. After a while they become almost as important as the fifth string on the guitar.

**Synapse:** Are you running any other instruments through the synthesizer, like the drums?

**Todd:** The drums are processed at the mixing console with similar things. All the effects that we have could be produced at the console but we have control over them.

**Synapse:** You have individual control over a set of studio modules and your soundman has control over the whole group through another set of modules?

**Todd:** Yes. It's a modulated group.

**Synapse:** Are there any instruments that you feel should be developed?

**Todd:** There is no good synthetic percussion device, maybe because there isn't a theory of synthetic percussion.

**Synapse:** Have you tried a Synare?

**Todd:** Haven't tried that . . . I don't know, maybe I have tried it.

**Roger:** Is that a mono instrument?

**Synapse:** Yes.

**Roger:** That's essentially what's wrong. There's no point in having a mono instrument. That's the same as having one drum with infinite tuning. What you want to have is different attacks and timbres and things like that rather than one drum with different notes or different volumes; it's the same as the Moog drum, it doesn't matter how many more pads they give you, if you're only running essentially one basic sound. Also drums invariably sound better as drums than as clinks and clunks, you know, they just have more power. There is very limited use for a percussion synthesizer until someone develops a whole theory of synthetic percussion which no professional percussionist of note has devoted himself to so far as I know.

**Todd:** In other words, the synthesizer became validated as an instrument, not because of Rick Wakeman and all those who popularized it, for he is essentially a keyboard player and devotes a little bit of time to the synthesizer. It becomes established as an instrument more because of people who devote something, either to

development of technique, for instance Jan Hammer or for instance Roger, who has, for all practical purposes, given up all other keyboards for a synthesizer at this point, and is going to devote himself totally to exploiting the possibilities of that, and until a drummer will give up totally all of his drums to devote himself to a new approach to percussion, it will essentially always be a compromise, whatever attempts people make so I think that percussion is the farthest behind.

**Roger:** Yeah, well the thing is, drummers ordinarily are not the more technologically minded people anyway. They aren't the people who have to deal with electric instruments. Guitar players and especially keyboard players have really had this burden in a certain sense; these people are the ones who are exploring the more electronic areas so what we need is to have a drummer who knows enough electronic theory and also has that motivation that Todd was talking about, to get together to have these two things meet.

**Synapse:** Have you had any training in electronics?

**Roger:** Not in terms of actual circuit design. I know Ohm's Law and I was a radio announcer and disc jockey for a while. I know a little bit about how electricity moves around in a circuit but it's too intricate for me to actually design something and be assured that it would work and be the latest. But you know, I picked up enough of the terminology and enough of the "mechanics" of electronics, if you will, that I know generally what's possible and I could specify how things should look and work on the outside which is a real key to getting them designed anyway, but you have to make yourself aware of enough of it to be intrigued by the possibilities and to know sort of what can be done.

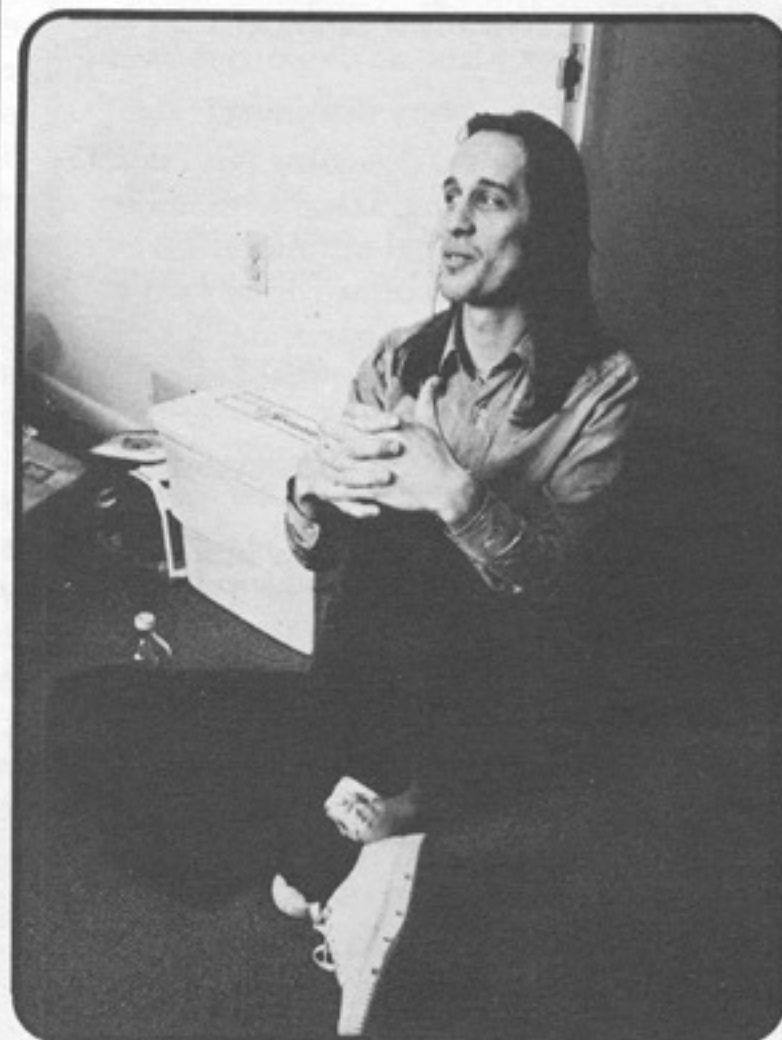

Todd Rundgren





PHOTOGRAPHS BY EVE KESSLER

. . . . and, of course, an ankh-shaped guitar.

**Synapse:** How about you, Todd?

**Todd:** I don't have any training in anything.

**Synapse:** Do you do any designing?

**Todd:** I do theoretical designing but I don't do any concrete designing. I deal with it from the idealistic end; like what ultimately do I want it to do. I have had some contact with it, you know, and it's not a particularly difficult thing to learn. It's just that I'm so occupied with other things.

**Synapse:** Do you feel you understand what's happening?

**Todd:** Oh yeah, I mean, I know more about it than the average musician. I have put together my own 16 track studio and my own video studio. It's just that I personally don't have the discipline in that area to sit down and maintain a thread of thought

through a whole electronic circuit. It's a difficult thing for me to do. I could condition myself to do it but I have other things that occupy me anyway.

**Synapse:** Could you tell me something about your show? What you're doing technologically and what you're doing visually?

**Todd:** While the show is meant to reflect something on as many different levels as possible, it's sort of a little bit like getting into the realm of magic, because some of its technology is so advanced and inaccessible to the general public, even other musicians. Also we've been working at . . . it with the intention of eliminating a lot of unnecessary interface like knob twiddling and tuning and things like that, so in that sense it goes one more step beyond just mundane technology

as people think of it. It becomes more accessible to you as a creative musician and less as a creative technician. In other words, the technology is being made simple to address and still maintaining the flexibility so that we can be free to be creative with these tools, and that's one of the objectives. If you spend too much time fiddling around with the equipment, then it's almost better just to go back to amplifier and guitar and not fuck with it.

**Roger:** You have to make a quantum leap, you can't go half way and get things done just right.

**Synapse:** I heard you were using laser beams and video on the show.

**Todd:** The video has been transferred to film. There's no adequate way of projecting video without creating a lot of technical impossibilities . . . and so it's being transferred to film and will be projected.

**Synapse:** You did the video on your studio?

**Todd:** Yeah, it's our studio.

**Synapse:** And is it using a video synthesizer?

**Todd:** Yes, a lot of it's synthesized and some of it is not synthesized.

**Synapse:** What type of video synthesizer is it?

**Todd:** There's a couple of them. There's one from EMS, the Spectron Video Synthesizer and one from a company in Philadelphia, called BJS, it's called the Chromaton. I have a couple of custom made pieces of equipment and a few colorizers and switches. The usual junk that you need to keep a video studio working.

**Synapse:** Do you do any interface between the sound and the image?

**Todd:** So far we haven't done any direct interface. I mean there is some minor interfacing, for instance we modulate aspects of the picture with sound but there are technical limitations in that as well, for instance the appeal of video synthesis as compared to audio synthesis is still primitive. It's been less exploited in a way. It's a much younger field and a lot of the things we'd like to have control over, we don't yet have control over.

**Synapse:** But is the music that you do on stage in any way an analogy to the video or doesn't it matter?

**Todd:** The imagery is made to complement the sounds but as opposed to normal video we're using a lot of abstracts, shapes and colors. It's an extension of the approach in music to try and cause people to visualize in a more sophisticated level.

**Roger:** The video's not happening while we're playing. It's not happening





simultaneously. It's a preproduction thing that was done.

**Synapse:** *Do you have to transfer it down to 16 or 35 millimeter?*

**Todd:** Yeah, one or the other. It would probably be 16. I think that's adequate with the proper projector. With 35mm, the projector is just too big. We have other effects that we use during the show while we're playing like a laser. We have some special lighting, some special visual effects like fountains and flames, and wind . . .

**Roger:** Sleet and snow . . .

**Todd:** And acrobatics and all kinds of stuff.

**Roger:** Tornadoes . . .

**Todd:** A real theatrical affair. For the last couple of years we've been mostly just playing. We haven't dealt with the theatrics or props, or the sets. In fact, gearing up to using this stuff has taken eighteen months. This has been in construction for six months at least.

**Synapse:** *You also did a new album that was just released. Would you like to say anything about the new album?*

**Todd:** Well, it's new here, but it's not new to us. It came out in Japan in December when we toured there. It was finished long before that so we're gearing up now for two months on the road after which we've got to come off and record another album, so that's much closer in a way than the last album is. The album essentially was sort of like the sound track to our performance and so the performance to us in some ways is more relevant than the album. The album is like a record of the performance. We haven't gotten to give the performance that the record was made for. We intended to be doing this performance earlier but the technical things weren't ready. Roger just got his probe last week and a lot of things seem to have taken a while to get together. So now we're finally getting to perform the show that the album is a record of.

**Synapse:** *Can you explain a little bit more about the probe? I think that people who read the magazine will be very interested in some of the things that it can do.*

**Roger:** Well, I can get into a little more detail about it. The key thing was to have an instrument that could play chords and which would allow the performer in a contemporary group, whose usually barricaded behind a lot of keyboards, enough sound variation and polyphonic capability, that he could just use this one instrument. So to overcome this problem, the first thing we had to do was isolate the keyboard from the synthesizer. I had to totally, well, I didn't do it myself, but I have an engineer who was a partner with me in

this venture and he had to totally redesign a keyboard. The keyboard is now using aircraft gauge aluminum instead of steel for it's framework and specially fabricated nylon parts and plexiglass pieces here and there. The keying system is not a buss bar system as is usual. There are photo isolators. Actually I think they are called "Opto" isolators, which are little LED's with photocells mounted across from them and then a key is depressed, a plexiglass baffle mounted on the key goes inside and breaks the light connection which means that there are no touching parts on the keying system. All the keys on the keyboard, which is four octaves, and all the switches which I have mounted on the instrument, which amounts to about 25 or 30 switches, are scanned by the same scanning circuit, so every 100 times a second, all the keys and all the switches are scanned to see which ones are depressed. A lot of this



**Roger Powell with his Probe Keyboard System.**

information is serially encoded and then sent down a quarter inch cable, which has 19 information channels. That connects back to the synthesizers which are off the stage. Built into the synthesizer is a preset memory bank which allows you to set up 16 master presets. Each master preset could be set up so that all six voices were the same, or to the other extreme, you could have six different voices set up for each present. This is useful in some cases where you're suggesting more than one instrument at once. At the left hand end of the keyboard there's a special area for the left hand to slide in to. There's actually an opening in the instrument, which allows the

four fingers to position over potentiometers which control more important aspects of the sound such as the volume, the speed of modulation/or vibrato, the detuning of the second bank of oscillators from the first bank which gives you chorus effects and out of tune rinky dink piano types of sounds. You can close all six filters all the way down and get a very mellow kind of sound and by rolling your finger on this control you can open the filters up and get a very dynamic brassy kind of effect. The thumb is sort of hidden underneath the instrument, in back, in its own contoured area where there is a pitch bend wheel and a modulation wheel, a similar technique as to what's used on a Minimoog except of course in this instrument it's all six voices at once. And then the banks of switches that I had do various things, like transpose the oscillators up and down octaves, turn the second bank of oscillators on or off, send modulation to the first bank or the second bank or both or selects pulse wave modulation; all the keyboard logic controls are there. I can play around with how the modules are assigned from the keys after they're scanned, they can either be scanned continuously so that every time you play a key you get the next voice in succession, one two three four five six, or if you've only played one or two notes and you hit it again it will go back to one. Basically all the keyboard logic that I had access to in the module itself is available at the keyboard and that's pretty much it. The case is fiberglass. The whole keyboard weighs eight pounds which is two pounds less than a Les Paul guitar and, let's see, so far it hasn't blown up. I would like to add that it was engineered and manufactured for me by the Royalex Company in Dover, Massachusetts and I'm very much indebted to Jeremy Hill who was the project engineer. I mean, I paid him his money but I'm still sort of indebted to him for making it happen.

**Synapse:** *Do you think that electronic music is going to be much more widely used and accepted due to the freedom of the instruments that are being created now?*

**Roger:** I just want to say something real quick about that. People are listening to electronic music and they aren't even aware of it. Any time you go to a rock 'n roll concert, or any time you turn your radio on; however that sound is originally created has then become part of the electronic music medium because it's been transcribed hundreds of times or how ever many generations it takes for the final product to reach you. So I think maybe that people will become more aware of what is actually happening but the future is here, you know. please turn to page 38





# THE SYNTHESIZER & THE LEFT HAND

by Craig Anderton

The synthesizer requires an approach that is different from any other instrument in order to exploit its potential to the fullest. One example of this is the inability of the average synthesizer to make chords; unless you have an expensive, custom synthesizer or a very new type like the Polymoog, chances are you can't use all 10 fingers of both hands as you would with a piano or organ. In this respect, a synthesizer resembles a super-versatile horn instrument capable of playing single note melody lines.

Another characteristic of the synthesizer is that unlike a piano, striking the keys with more force will not produce a louder sound. As a result, dynamics are not controlled at the keyboard itself but elsewhere in the system, as through the use of a footpedal. This is similar to an electric organ.

Some people would consider these features very restrictive, but only if synthesizers are approached as traditional keyboard instruments. A far better approach is to think of the synthesizer as having a melody played with the right hand on the keyboard, while the left hand works on the various dials and controls in the most expressive manner possible. The minimoog and other synthesizers take advantage of the available left hand to control two "tone wheels"—a pair of potentiometers attached to oversize knobs, designed for easy manipulation by the left hand. One of these controls the pitch of the note, so that turning the wheel one way moves the tone upwards in pitch; turning it the other way makes the tone slide down in pitch. A detent in the center makes it easy to come back to proper pitch. The other wheel controls the intensity of vibrato, so that the further the control is advanced, the greater the injection of vibrato into the main signal.

However, you don't need to have specially constructed tone wheels designed for the left hand and relegated to two specific functions—any knob on the synthesizer is fair game for being tweaked while playing. In fact, on earlier synthesizers which didn't have tone wheels, you still had access to knobs on the front panel that could do the same thing. Granted the tone wheels are designed more with human engineering in mind and are easier to control than a standard knob, but that does not make playing with the knobs impossible. In addition to what you can do with your left hand, you can also add a footpedal and obtain added control over parameters of the sound with your foot. By

being able to shape sounds dynamically as you play, you have a big sonic advantage over players who don't twiddle with the knobs and have to settle for stock and perhaps even trite sounding control settings.

Let's look at some examples of what you can do with the average synthesizer to add interest to your playing, and get away from the voltage-controlled sound . . .

**OSCILLATOR FREQUENCY CONTROLS**—Many synthesists use the sound of two oscillators (a master and auxiliary), slightly detuned from each other, to obtain a fatter, richer sound; the principle is similar to using a 12 string instead of 6 string guitar, or using multiple strings for each note of a piano keyboard. However, you can add a very dramatic effect by starting out with both oscillators tuned very closely to each other, and then slowly tuning the auxiliary oscillator more and more off pitch with your left hand while playing a melody line with your right, then bringing the oscillator back to pitch again. Although this effect could be controlled by a control voltage like a sine wave, the effect is too regular and the most detuned part might happen when you least want it. By manually varying the oscillator you can emphasize and build more tension and release into your solos through selective detuning. To finish off the solo, in fact, you might just detune the auxiliary oscillator up until it becomes exactly one octave above the master oscillator (or whatever interval is musically appropriate). This takes a good ear and some practice, but isn't too difficult once you acquire the knack. Should you at some point find yourself lost in the knobs with one oscillator becoming horribly out of tune

---

**By adding some of the irregularities found in our customary instruments, the synthesizer takes on a much more human and fallible kind of expressiveness.**

---

through your diddling, don't panic—slowly fade it out and let the other oscillator carry the line.

Although this next technique requires considerable practice, the effect can be very stunning. Instead of slightly detuning one oscillator, try adding a manual vibrato to the tuning knob. You will not be able to imitate the precision of a voltage controlled vibrato, but that's exactly the point. The slight imperfections and changes add a remarkably human quality to the sound. Also, one of my favorite tricks is to introduce a manual vibrato while the oscillator is tuned, say, 2

whole steps above the master oscillator; and then, while continuing the manual vibrato, tune the second oscillator downward to match the pitch of the master oscillator. Although these effects may be implemented with appropriate control voltages, manual control gives more flexibility.

**ENVELOPE GENERATORS**—One aspect of the synthesizer that has always bothered me is the envelope control of notes. Once you set a decay level, for example, you are committed to that decay level for every note on the keyboard (with the majority of synthesizers). With traditional instruments, this is seldom the case, with bass generally decaying over a longer period of time than treble notes. By manually varying the attack and decay times of a line while you're playing it, you can add much color. For example, let's suppose you're playing a fairly staccato passage, with a small amount of decay set for each note. On the last note of your solo, crank the decay knob up full, and you'll get a nice long decay that fades into the distance rather than just disappearing. Another example: if you're playing a bunch of notes with short attack times, try lengthening the attack in a more or less random manner; the result will be very much like a traditional instrument played "backwards" via tape techniques. A constant attack (or decay) characteristic is much less interesting, sounds quite stereotyped, and has a vaguely mechanical feel that makes the synthesizer sound less integrated into an ensemble of traditional instruments. By adding some of the irregularities found in our customary instruments, the synthesizer takes on a much more human and fallible kind of expressiveness.

**PORTAMENTO**—Once people click on the portamento switch, they tend to leave it there. However, if you switch the portamento in and out with your left hand so that it's in for only about 10+ of the notes of a solo, the effect becomes much more dramatic. This function also lends itself well to footswitch control in case you don't want to tie up your left hand. Having the familiar portamento gliding sound throughout a solo can sound pretty gimmicky; but to have a couple of slides appear in the middle of a run is something else altogether.

**FILTERS**—Traditionally, synthesizer players automatically hook their filter cutoff frequency to an envelope generator, and all the comments given before about envelope generators apply here also. This gives a neat sound, but again, one which has perhaps been overused. Try disabling the control voltage and vary the cutoff frequency manually. You will not be able to match the speed of response of the envelope generator, but you can slowly vary the cutoff frequency for a wa-wa type effect. One very effective way to use this technique is with a rhythmic, sequencer-like melody line. You can play a figure over and over again, constantly raising and lowering the cutoff frequency of the filter in time with the music. The same scheme is also very usable with the Q (or resonance) control, where you can turn it way up to accent certain



notes and then return it to normal for the rest of a run.

On slow passages you have another bonus of handling the control voltage manually; you can create an actual envelope if your fingers are fast enough, but these envelopes can be different for each note—something that would be very difficult to accomplish with a control voltage. Although you may feel clumsy when first attempting manual control of something previously handled via electronic regularity, practice makes perfect and this is no exception.

**REVERBERATION**—Reverb is generally used as a static, set-and-forget type effect. One reason for this, perhaps, is that there is a fine dividing line with reverb . . . a little bit is hardly noticeable, and too much sounds kind of cheap. Here's another place for the left hand to shine, but this effect may not be obtainable with every synthesizer. You have to be able to control the amount of signal going into the reverb section (reverb send) rather than the output of the reverb section (reverb return). If you have access to reverb send, though, here's what to do. As soon as you strike a note, kick the reverb send up full, then immediately pull it back. The reverb "sees" just a pulse of music, and creates an almost explosion-like sound that accents a note very strongly. This also provides an ideal way to get out of a solo: slowly increase the reverb over the course of the solo, then for the last note give it a real kick. The effect is that the music seems to become more and more distant, until it "explodes" and naturally fades out of its own accord . . . with a nice long decay time.

**RING MODULATION**—Controlling the carrier frequency of a ring modulator manually gives much more expressiveness; and if you get really good at it you may even be able to have the ring modulator effect "track" the notes you play on the keyboard in a consistent fashion.

Different synthesizers, of course, offer different features; but the basic ideas presented here are applicable to almost all of them. But in order to turn voltage controlled functions over to manual control, you have to become really familiar with your axe and especially how the various controls affect the sound. Also, you may want to replace the knobs of often used controls with bigger knobs that are easier to control. One more note: I find that rotary pots have a better "feel" for manual control applications than linear slider pots. A good feeling, high quality rotary pot is also less expensive than a linear pot of comparable quality.

Music is all about expression—and if you let a machine do the expressing, your music may acquire a machine-like feel. Return those effects to manual control and you'll be one step ahead of those who set up a specific patch on stage and are afraid to mess with the dials. Sure, you run the risk of turning the wrong knob by mistake and blowing it; but if you know your instrument you can recover. On the positive side, you've opened up your axe to a much freer mode of expression. ~~~

# RING

**Ultra stable oscillator with foot selectable preset frequencies. Automatic squelch inputs for optional pressure sensors (pedals) controlling the amount of modulation (0-100%) and/or glisses of the modulating frequency. Long 9v. battery life.**

**Cost: \$150.00 C.O.D. only, Calif. residents please add sales tax. Pressure Sensors are \$32.00 each.**



**SYNERGY ASSOCIATES  
1107-1/2 N. Western Ave.  
Hollywood, Calif. 90029**

**P.S.\***

**SYNARE**  
\*percussion synthesizer

The beat goes beyond. The world of electronic percussion is yours with the Synare P.S.™ . . . the first fully integrated percussion synthesizer.

Put thunder, lazy days, chimes, brake drums, gongs, jackhammers, rain, rush hour . . . under your sticks. Designed for use with or without a drum set, the Synare P.S. is played with sticks like a drum, has bounce, and requires only a conventional sound system.

P.S. Write for information about the Synare P.S., the first fully integrated percussion synthesizer, and the dealer nearest you.

Suggested Retail \$795.00

**STAR INSTRUMENTS INC.**  
Dept. S, Box 71, Stafford Springs, Ct. 06076 tel.(203)684-4421



A U D I O

V I D E O

S Y N T H E S I S

*IN AN AGE so dominated by television and pleas for integration, it is not surprising that "art" would mirror these social interests.*

*In this article, author Jerry Hunt discusses audio/video synthesis as a logical extension of sound composing and illustrates the problems and advantages of interactive audio/video synthesis.*

---

*by Jerry Hunt*

---

For me video is a direct, immediate, and natural global extension of the compositional activities associated with sound. I have not and do not now distinguish between electronic and non-electronic means as a procedural definition. Video is an electronic environment extending from the theatrical reality of producing sound; similarly, audio is an extension from the environmental necessities of sound producing.

My background and training has been exclusively concerned with sound production, as a pianist and composer (1950-1960) engaging in compositional and performance activities which increasingly utilized electronic resources. David Dowe's specialization of training is visual, and the history of visual thinking in his own development is as extensive as mine has been in an aural orientation. This I think suggests something of the successfulness of our approach for us: the compositional activity can be highly specialized to take full advantage of the workers involved, and at the same time the

system procedure (audio/video together) provides a situation of equivalency in variational decision-making.

The method, compositionally and procedurally, of working with interactively adaptive audio-video systems has also led to a reorganization of our thinking habits associated with the disciplines of music, film, painting, sculpture, dance, and theater. From my own independent work before association with David Dowe and the Video Research Center, I have developed a group of procedures and systems for the audio and video components of my compositions. Gradually areas of contact between audition and vision became more clearly self-evident. The early independent work and my work with David for the past five years has substantially reinforced my original intuition that the composing activity can powerfully operate and should operate in ways which are not dependent upon the patterns of feedback and feedaround through one special orientation of thought (action and process).

The perceptual, structural, and dynamic modalities of image and sound are profoundly

unique and different in sometimes difficult ways. Certainly in regard to the requirements of parameter pattern extraction from signals produced by video cameras and microphones, these differences become exaggerated. The fortunate circumstance of systems for the electronic generation of image and sound is exactly that the parameters required for effective and powerful interactive operation exist in separable, definable, pattern-coherent structures, and the signal formats can easily be made compatible. (Unfortunately however, this in no way provides solutions to the still difficult synthesis problems for such systems).

Some aural/visual correlates seem to possess perceptual and/or historically reinforced constants of association—for example, the variation of average luminance in a visual display space and the dynamic variation of the intensity/spectrum relations of sounds through loudspeakers, and image orientation with reference to the viewing frame and sound distribution (regarded in both spatial and spectrum modulation aspects). Even more interesting was the situation in which image,



(still—in a spatially defined viewing space), and sound (rhythmic/melodic *drone*) could be associated over a limited but highly variable range of characteristics. Furthermore, in this special situation provided by electronic systems, the variational histories of developments of characteristic features of dynamic pattern-sequences of sound and image can become the central compositional procedure.

Special attention to two areas of work became necessary to meet the demands of composition in this assumed interactively adaptive situation. First, the systems for signal generation had to be implemented in such a way as to allow selective parallelism of dynamic variation in image and sound and yet provide sufficient control flexibility/predictability to preserve the specific characteristics and integrity of a possibly large repertoire of image and sound development. The audio and video generators were implemented and have been continually modified and updated with the constant objective of increasing the integrity of *ensemble dynamic* parameter variation. (In electronic music systems the greatest problem in emulation has been in this area.) The objective required very early in the development of the signal generating systems a movement away from modular conception to a more integrated global structure. Second, because parameter-structure variations of image and sound develop in dissimilar ways, a system for extraction and analysis of ensemble-pattern over short-time histories was essential. Although unexpected, the results of *direct* interconnection of signals and controls are predictably limited and trivial.

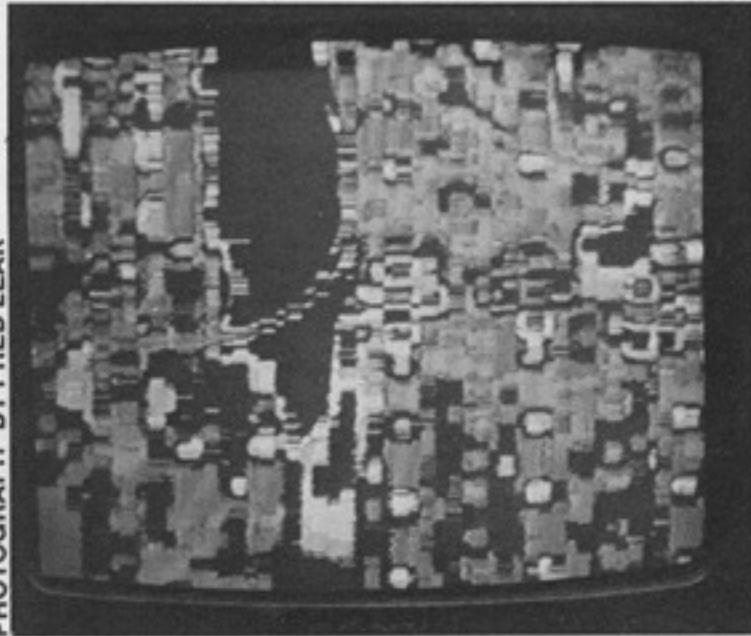

A video image created with Jerry Hunt's and David Dowe's audio/video synthesis system.

The accompanying block diagrams illustrate the organization of the audio and video generating systems, the interactive-adaptive processor used with these systems, and a smaller derivative system of recent design for use with performances involving voice and voice emulation and specialized generators for image-sound.

The *audio generating unit* is a four-voice system organized as a parallel processor. All the function-subunits employ primarily ana-

log electronic technology; all the static programming, matrixing, and routing subunits utilize digital implementations. A ROM<sup>1</sup> plug-in relates an array of 128 switches to major static program changes, allowing continuous performance manipulation. All parameters of all subunit functions are completely electronically presettable and full-range variable. Spectrum specification, formant, frequency, waveform, and amplitude modulation processes are all dynamically interrelated

signals and electronically generated video signals can be simultaneously accessed and accommodated. Subunits of the system perform basic video processing tasks: arbitrary colorization and color modulation, spatial and textural reorganization of the images in the display space, edge/line derivatives and modulation (PWM, PPM, PAM<sup>4</sup>), chroma<sup>5</sup> and gray-scale<sup>6</sup> modulation, etc. The subunits are also isolatable (including external patch interfacing and switching). This feature was

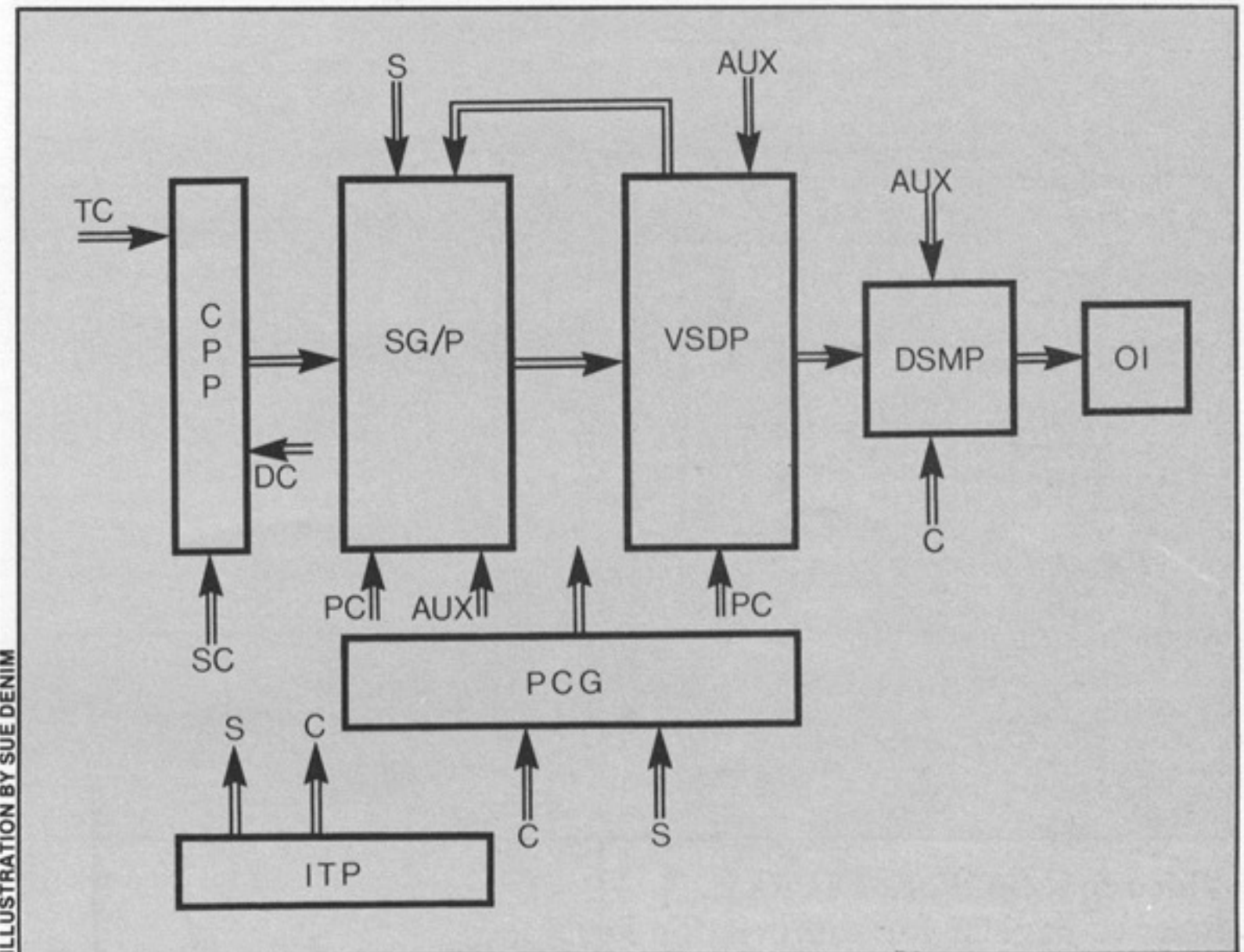

Audio System Block Diagram. Refer to page 29 for abbreviation key.

by user-defined specifications. Electronically programmed multiphase function generators operate on all levels of the system subunits and may be dynamically controlled. The input transducer ports accommodate a complement of a pressure/pressure-derivative sensing keyboard or, interchangeably, a similarly responsive band-controller, two three-dimensional foot pedals, and two three-dimensional trackers (one rotary and one similar to a joystick-array). The output structure allows re-entry and parallel organization of separate processes and signal channels. A component of the output subunit consists of a generalized delay processor which allows specialized spatial, spectrum, and frequency modulation.

The *video generating unit* is a multiport input system also organized as a parallel processor. The system is completely synchronous: all waveforms and modulation involved in video generation of primary processing loops are related to the composite synchronizing signals<sup>2</sup> employed in NTSC<sup>3</sup> color video. The system generates up to six separate electronic images in the display space (television color monitor), and video camera

necessary to satisfy the requirements of widely divergent applications of the system. Subunits for generating groups of electronically variable waveform sequences produce basic image structures; modulation of these subunits produces images in an arbitrary-scan format. Independent electronic control is available for spatial transformation and

**The perceptual, structural, and dynamic modalities of image and sound are profoundly unique and different in sometimes difficult ways.**

translation of images, movement, size and distance, apparent distance, surface and "environment" texture and shading, and viewing angle and color. A scan-conversion subunit



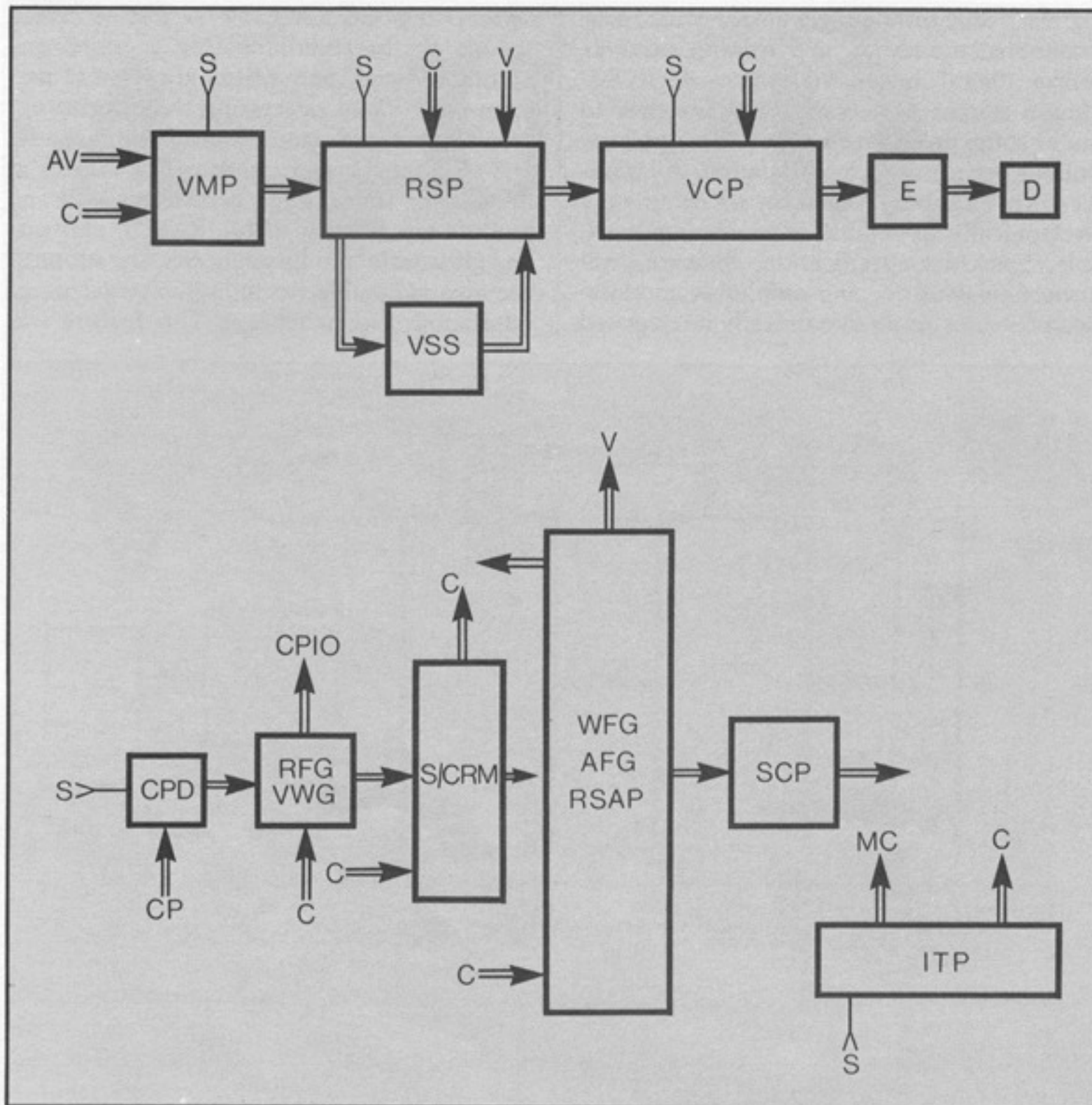

**Video System Block Diagram.**  
Refer to page 29 for abbreviation key.

performs the format translation for NTSC and is input-output uncommitted to allow electronically generated and camera-scanned signals to be interchangeably processed, mixed, and routed. The scan-converter subunit is an optically coupled system; a selective digital framestore subunit allows the static storage, delay, and processing of limited image feature-extraction components. The final mixture of signals is encoded into the NTSC composite color video<sup>7</sup> signal and displayed over color television monitors, video recorded, and/or broadcast through standard television transmission systems.

The *interactive processor*, like the generating systems, has been continually altered in implementation and structure and has undergone two complete rebuildings of hardware since 1972. Control signals describing an array of parameter designations to be monitored from the two systems are scaled and modified for electrical compatibility and each routed to one of three varieties of preprocessors. Slope derivatives of dynamically varying controls and synchronizing signals control the access to these inputs. The preprocessors perform in each parameter channel a non-linear adaptive filter<sup>8</sup> function; several channels allow sampling functions and/or delay processing. Programmable weighting and matrixing is then performed to produce

groups of unique signal branches. Processors similar to adaptive linear variable-threshold amplifiers<sup>9</sup> are then utilized to generate sequences of parallel pattern codes which are stored in a recirculative memory system.

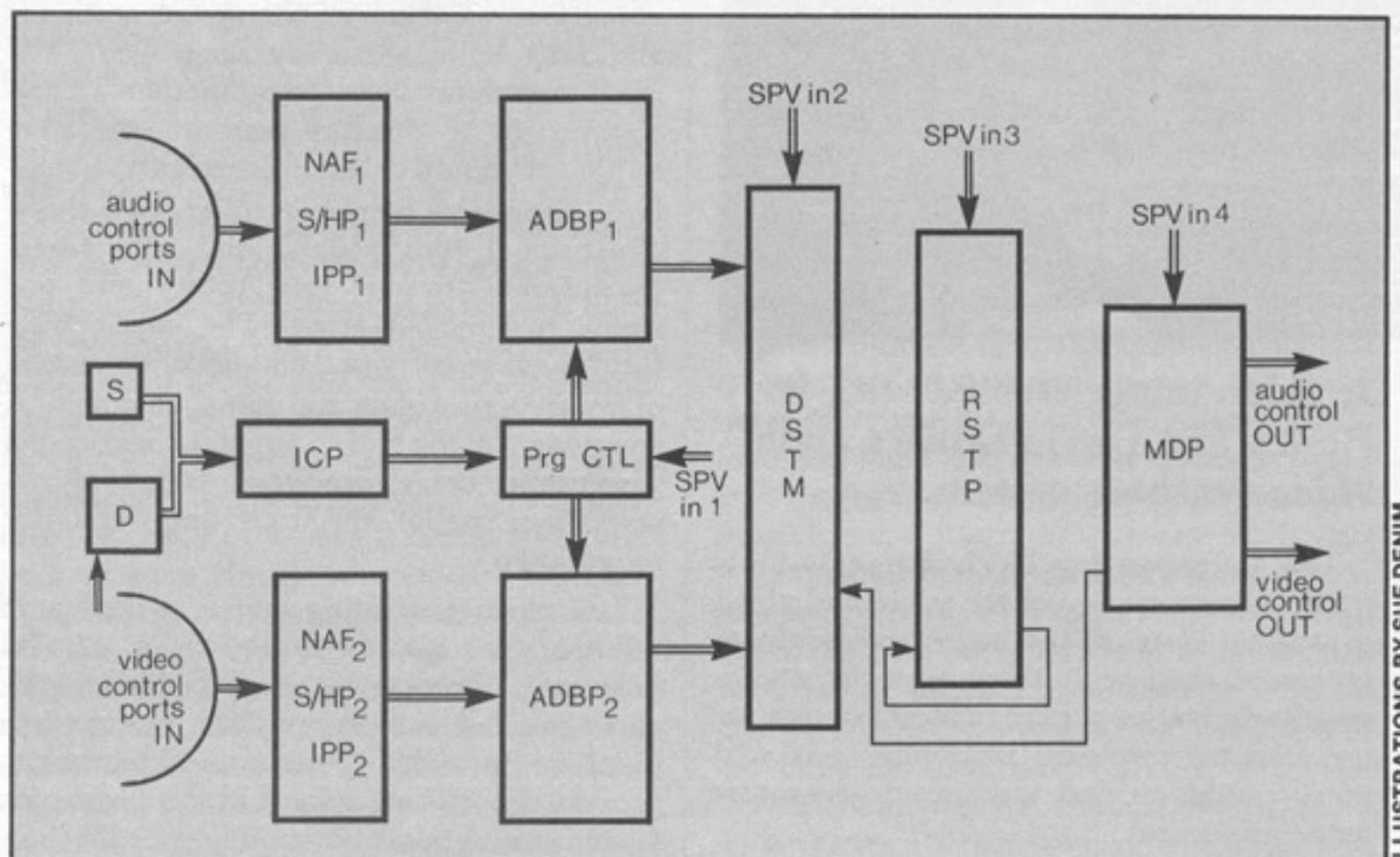

**Interactive Processor Block Diagram.**  
Refer to page 29 for abbreviation key.

Programmable dynamic 'template' models are applied according to program instructions which provide for dynamically variable goals under some arbitrary set of limits. This process is cyclic and continuous and produces, in relation to input signals, output codes which are dematrixed and arithmetically manipulated to generate for the audio and video systems two separate groups of interrelating parameter controls. Pre-program settings establish degrees of parallelism and 'goal-pointers' between image and sound parameter designations. The control signals to and from the generating systems are routed using firmware connections and may therefore be arbitrarily assigned to a given channel location.

The large system has been employed to produce components of audio/video recorded work, but primarily it has found use as a system for investigation and dynamic real-time performance operation (*Haramand Plane*). The smaller, derivative special purpose system (used for performance of my *Cantegral Segment (s) 19, 20* and David Dowe's *Repons*) and its associated synthesis modification systems have been developed since 1975 as a direct outgrowth of the larger system. The signal sources involve microphone and camera transducers (and interchangeably since January 1977 a performable voice-emulator and special image-synthesizer). Image and voice parameter extractors operate on a limited selective range of features to provide strings of signals which control the variation of the processors (and/or generators) with respect to dynamic performance definitions. We do these works frequently on tour since they are more easily transported, adaptable to various circumstances, and require minimum rehearsal and set-up.

No specific philosophy of design or technical suppositions have been imposed upon any subunit or system aspect of the devices other than electrical compatibility and all-electronic

ILLUSTRATIONS BY SUE DENIM



Since the beginnings of our work independently and later together, most of the technical and developmental work has been financed by us directly (with the very important exceptions of the National Center for Experiments in Television in San Francisco at the time of establishing the Video Research Center and, currently, the Rockefeller Foundation). This fact and the important influence of constantly re-evaluated cost/performance assessments have been, I now think, frequently fortuitous forces in defining proposed implementations. A further auxiliary observation of increasing importance for me was the byproduct of work on coding and pattern recognition theory during preliminary study

and auditory space—for the video particularly a 'tactile' element seems to develop as a side benefit. Third, the interactive systems are in no way "sequencers" or randomizers but rather responsive mediums of information exchange and extension. Although not intelligent in a cybernetically austere sense, the systems have begun to produce for our work some results which suggest several modes of re-orientation for us: composition is dynamically related to the responsive cycles of activity required (composition as performance); goal setting and patterning in this dynamic activity of composition dissolves some aspects of the image/sound separation; finally, and most importantly, pattern-struct-

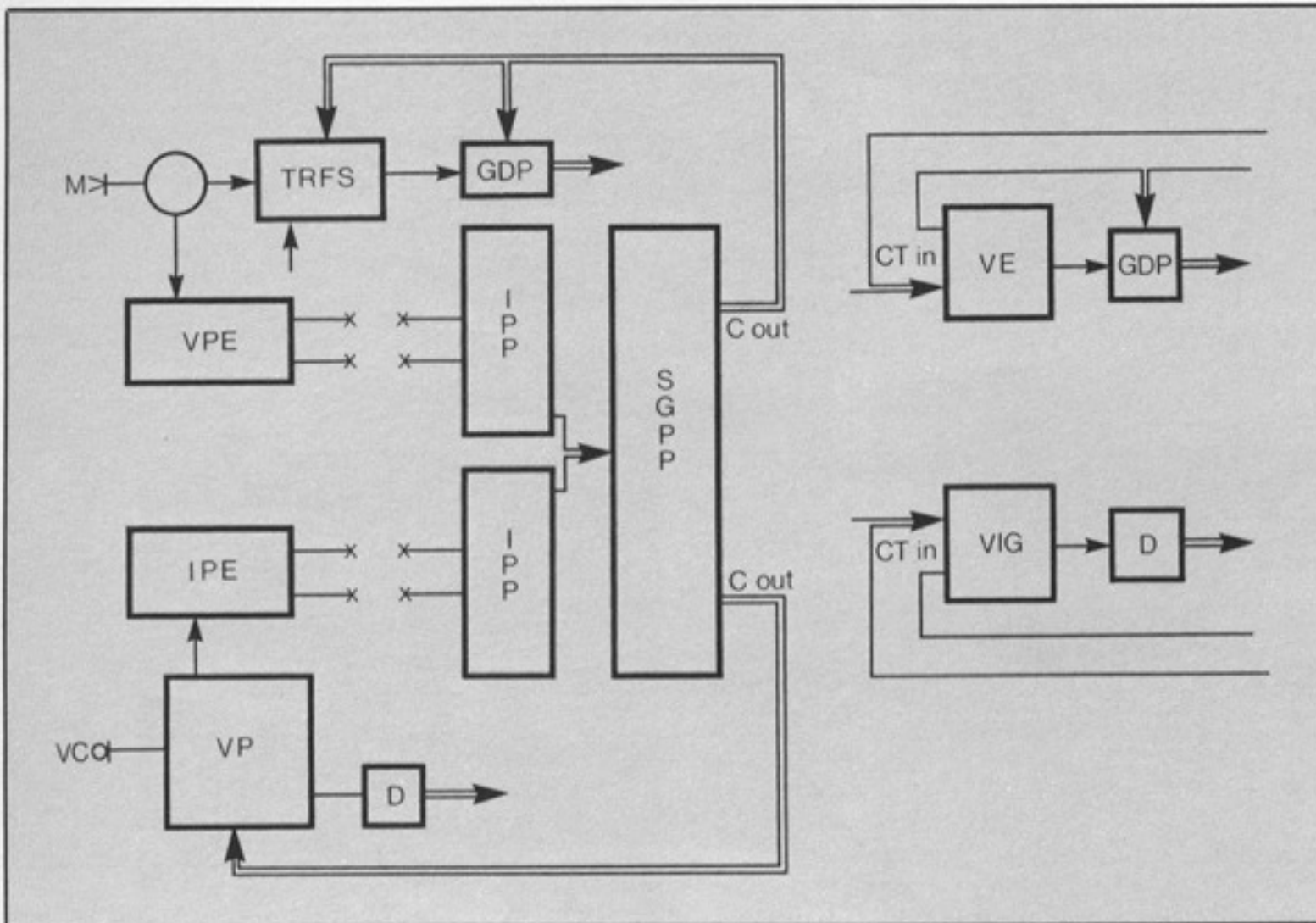

### Cantegral Segment(s) Processor with transducer pickup and direct versions.

for my work *Haramand Plane* (the first of our works interactively executed): an insight into the possibilities of virtual high-level operations using carefully limited computation and storage elements. This observation involves economics in no way related to technical or financial considerations but informs directly the eventual result for electronic art activity generally.

Finally, for our work together involving interactive processes, several delightful situations occur. First, because of the system structure of the audio and video generating units, dynamic sequences of deviation from *still* (video) and ornamental *drone* (audio) can be arbitrarily interrelated by a wide range of different variational principles. At the same time complete performance autonomy is maintained. Second, because of the dynamic provisions, both systems are essentially performance instruments (this is important even in recorded, highly editorial modes of working); this fact encourages the finding of ways of working which sometimes closely correspond to the experiences of encounter in visual

turing formalities emerge which relate to a procedure which approaches one of my long-felt enthusiasms for electronic means—an almost colloquial and at once multidimensional/global exchange of aspects of the perception of living. ~~~~

### Video System

- S sync
- Avin auxilliary video inputs
- Cin control inputs
- Vin primary video inputs
- RSP raster-scan processor
- VSS video selective frame storage
- VCP video colorizer-processor
- E encoder (NTSC)
- D distribution driver
- VMP video mixer/processor
- CPD clock processor/distributor
- CPIO camera processor-inputs/outputs
- RFG raster function generators
- VWG video waveform generators
- S/CRM signal/control routing matrix
- Cout control signals-outputs
- WFG waveform function generators
- AFG arithmetic function generators
- RSAP random-scan arithmetic processors
- SCP scan-conversion processor
- Vout video outputs

- ITP input transducers-processors
- MCout matrix/routing controls out
- CP clock program (input)

### Audio System

- TCin transducer controls-inputs
- SCin static controls/presets-inputs
- DCin dynamic controls-inputs
- ITP input transducers/processor
- S sync
- Cout controls (all) out
- PCG programmable control generators
- Cin control inputs
- PCin program controls-inputs
- Aux in auxilliary program or signal inputs
- VSDP voicing, spectrum, distribution processors
- DSMP distribution and spatial modulation processors
- OI output interface (mixing, drivers etc.)
- CPP control program/processors
- SG/P signal generators/modulation processors

### Interactive Processor

- S sync
- D slope derivative generators
- ICP input control processor
- Prg CTL program control
- SPV status program variables
- NAF nonlinear adaptive filters (preprocessor subunit)
- S/HP sample-hold processors (preprocessors subunit)
- IPP input signal preliminary processing (Preprocessor subunit for scaling etc.)
- ADBP arithmetic, distributive and 'blend' processors
- DSTM dynamic sequential 'template mapping'
- RSTP recirculative sequential template processor
- MDP matrix decoding processor

### Special purpose processor system

- M microphone
- VC video camera (B&W)
- VPE voice parameter extractor
- IPE image parameter extractor
- VP video processor
- D display (distribution drive etc.)
- TRFS transversal/recursive filter structure
- GDP generalized delay processor
- IPP input control parameter processors
- SGPP sequential 'goal-pointer' processors
- Cout control out to TRFS control inputs and VP control inputs resp.

- CTin control transducers-inputs
- VE voice emulator
- VIG video image generator

<sup>1</sup>ROM—read only memory.

<sup>2</sup>sync—synchronizing pulses employed to establish time relationships.

<sup>3</sup>NTSC—National Television Standards Committee—used generally to refer to the electrical and related standards to which American television systems must conform.

<sup>4</sup>PWM, PPM, PAM—Pulse width modulation, pulse position modulation, pulse amplitude modulation.

<sup>5</sup>chroma—the color-information carrying component of a composite color video signal.

<sup>6</sup>gray-scale—the graduations of brightness between black and white in a television display or signal (luminance).

<sup>7</sup>composite color video—a signal containing timing (sync) chroma and luminance information electronically combined.

<sup>8</sup>nonlinear adaptive filter—a filter whose characteristics vary according to some function of the input/output relationships.

<sup>9</sup>adaptive linear variable—threshold amplifier—an amplifier whose region of linear amplification varies according to a required characteristic of the input/output.







# Find out why these people are smiling



Making music makes people smile... brings people together. And **KEYBOARD WORLD** brings everything together to show you how to get the most from your piano, organ, or synthesizer.



**KEYBOARD WORLD is why**

**KEYBOARD**  **WORLD**

- Send me 12 months of **KEYBOARD WORLD**! I've enclosed \$12.50. Send my gift issue:
    - June 75: Arrangement of "How Great Thou Art," OR
    - October 76: "Son of a Preacher Man," and "The Easy Winners" by Scott Joplin
  - Bill me later for \$12.50 and start my subscription now.
  - Charge my  BankAmericard  Mastercharge
- Account No. \_\_\_\_\_ Expires \_\_\_\_\_

please print

Name \_\_\_\_\_

Address \_\_\_\_\_

City \_\_\_\_\_

State/Province \_\_\_\_\_ Zip \_\_\_\_\_

Mail to: **KEYBOARD WORLD**, P.O. Box 4399, Dept. SM1, Downey, CA 90241. Offer expires December 31, 1977.



# COMPUTERS

Number =  $D_0(W_0) + D_1(W_1) + D_2(W_2) + D_3(W_3)$  General

$365 = 5(10^0) + 6(10^1) + 3(10^2)$  Decimal

$101 = 1(2^0) + 0(2^1) + 1(2^2)$  Binary  
 $= 1(1) + 0(2) + 1(4)$   
 $= 1 + 0 + 4$   
 $= 5$

Fig. 1

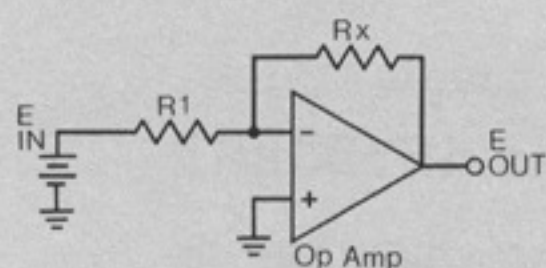

$E_{out} = -E_{in} \left( \frac{R_x}{R_1} \right)$  Fig. 2a

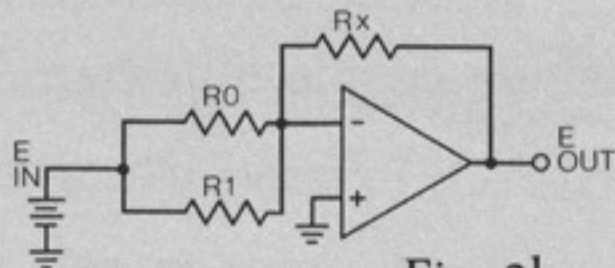

$E_{out} = -E_{in} \left( \frac{R_x}{R_1} + \frac{R_x}{R_2} \right)$   
 $= -E_{in} R_x \left( \frac{1}{R_1} + \frac{1}{R_2} \right)$  Fig. 2b

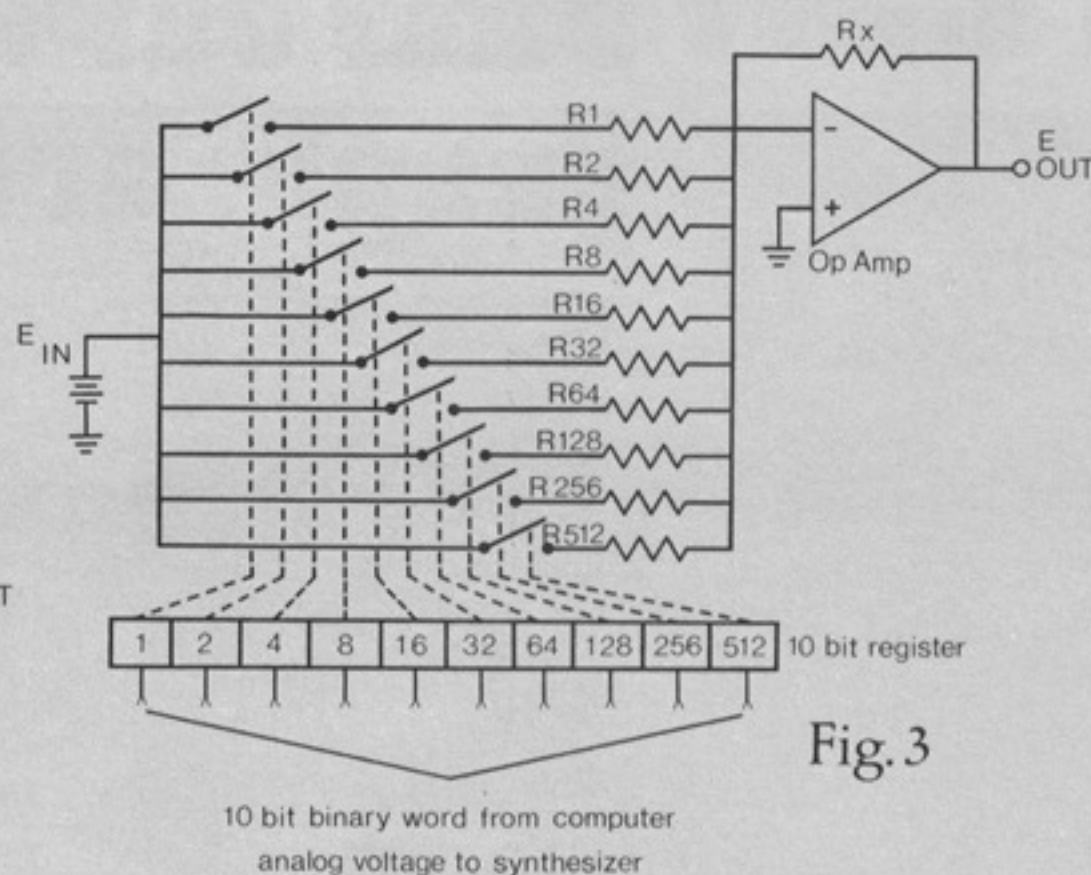

Fig. 3

ILLUSTRATION BY SUE DENIM

## The Link Between Computers and Synthesizers

PART 2

with Peter Hillen

In the last issue a specification was derived for a digital to analog converter that is suitable for electronic music applications. It has a full scale analog output voltage range of 7 volts which corresponds to 7 octaves in a lv/oct synthesizer. The digital word input is 10 bits implying that the resolution is one part in 1024 or 8.2 cents.

Now knowing these parameters let's see what goes on inside a D/A converter. There are several different techniques to derive the function of a D/A converter. One thing they have in common is that they all work on the same basic mathematical formula. The formula will give a clue to the operation.

Remember that binary numbers are just like decimal numbers in that the position of a digit in a number is important. To find the value of a number it is necessary to sum all the digits in the number taking into consideration the relative weights associated with the position of the digits. In figure 1, a generalized summation equation is shown along with two examples used in a previous article on computer arithmetic. A D/A converter is like the formula because it also sums together the binary digits taking into consideration the positional weights and produces a single value. The unique thing about doing this in binary is that there are only two values; 0 and 1. This means that a particular weight either does (1) or does not (0) contribute the total summed value of the number. In decimal arithmetic this is not true. For example, the 10's position of a decimal number can contribute anywhere from 0 tens to 9 tens. Binary makes the implementation of a D/A converter simpler because it is only necessary to sum together the weights having 1's in their digit position.

Electrically, let's assemble the necessary elements. First we need a summary device called a summer to add together the weights. Next we need something to generate the relative weights and thirdly we need a switch to connect the weights to the summer depending on the zero/one combination of the binary number being converted.

A summer is an analog function which adds together analog

voltages and produces their sum at the output. The classic way to produce a summer is to use an operational amplifier. Briefly an operational amplifier is an electronic device which has high input impedance, low output impedance and very large gain. The gain of the operational amplifier (op amp) can be regulated by the use of feedback. Figure 2a shows an op amp with resistor feedback. Without going into a lot of math its equation is  $E_{out} = E_{in} (R_x/R_1)$  where  $R_x/R_1$  sets the gain of the amplifier. If another resistor is added in parallel with  $R_1$  as in Figure 2b the gain equation for the op amp would be  $E_{out} = E_{in} R_x (1/R_1 + 1/R_2)$ . Additional resistors can be connected in a similar way. Notice the input resistors are additive in the equation and that the value of the resistor effects the output voltage. These resistors are called summing resistors. If the ratio of the values assigned to the resistors correspond to the weights in the binary number system then it is possible to produce the analog equivalent to a binary number just by connecting various combinations of resistors between  $E_{in}$  and the input to the op amp. The connection of the resistors can be accomplished by an electronic switch between  $E_{in}$  and each summing resistor. The electronic switch, which in most cases is a transistor, can be controlled by a particular bit in the digital input word. The bit position in the digital word would correspond to the weight of the resistor it is controlling. If that bit is a zero then the switch is open and the resistor is not summed into the value of the number being converted. If the bit is a one then the switch is closed and the contribution of the resistor is added to the total. Figure 3 shows a diagram of the conversion just described. The operation is as follows; the computer outputs a 10 bit digital word to the D/A converter. The word is stored in a register. According to the zero/one makeup of the word in the register the electronic switches are either opened or closed. The op amp sums together the resistors whose switches are closed and outputs the analog sum. The output is held at that analog voltage until a new digital word is presented to the input resistor. By adjusting either  $R_x$  or  $E_{in}$  the proper full scale voltage can be attained.

Next issue all of this theory will be put into practice with a simple D/A converter construction project. ~~~~



# PERFORMANCE



## Laserium Two

with Angela Schill

They led us into the double doors, past the central hallway and into a circular room with a planetarium dome ceiling drawing us into circles of seats with headrests.

To the left of the entrance sat the one watt krypton laser. It waited patiently until it was called upon by its other half—the control panel to the right. Waiting at the control panel until he was called upon was our laserist, the animate interface to the system.

Among the audience there was a lot of muffled talking and curious glances at the other unidentifiable mechanisms in the room while the real star of the show (the laser) sat quietly hidden in its blue box.

Suddenly loud pounding drums popped out of nowhere, the ceiling emitted a thick blue haze and at the center a small green laser beam appeared. The audience was silent, the room blacked out.

Small patterns of repeated green, red and blue beams split apart and turn inside out then explode filling the entire ceiling. The colors are brilliant. To this the music of Aaron Copland is choreographed. Next comes the evening's first of many synthesizer pieces, "I Remember Me," by Mahavishnu alumni Jerry Goodman and Jan Hammer. Goodman's violin is visually met by spacey blue rings, spirals, and multiples of star shapes.

The audience is jolted out of the tranquility caused by "I Remember Me" as John Phillip Souza comes booming in with "The Washington Post March". The laser lights break into twirling batons as they appear one by one and begin spinning to the tempo then change direction every three or four upbeats.

Many selections made good use of largely electronic music, including: "Elite Syncopation" by Scott Joplin (realized by the Eden Electronic Ensemble from the album "Plugged in Joplin"), "Second Voyage to Andromeda" by Timothy Randolph Clark (artist-in-residence at the McLaughlin Planetarium in Toronto, which also is one of twelve worldwide Laserium outlets). Clark's music, made up of the combined timbres of a synthesizer and tuned water glasses, was very complementary with the textures in the darkness above us.

Also playing was Larry Fast's realization of Mason Williams' "Classical Gas," (the audience really liked this one) and his own "Sequence: 14"; Danny Sofers' "Dan's Tune", a somewhat jazzy-disco piece using synthesizer coupled nicely with red and blue spirograph-type pinwheels that pulsed in and out of each other, (the audience reacted well to this one also) and of course, Gary Wright's "Dream Weaver" fit in well.

The audience reacted very positively to the unusual impressions about them; at times the group grew suddenly silent, overwhelmed by the beautifully hypnotizing lights heightened by their musical counterpoint.

The same high levels of quality and care to all aspects of this production were maintained throughout the entire program. Each piece was carefully planned for the strongest effect in contrast to the preceding piece, and all of them were well presented. Perhaps in the future there might be some efforts at developing a more extensive palette

of colors as the entire show was limited to yellow, red, blue and green. However, this was certainly not boring considering their brightness and manipulation.

But the grand finale was the most impressive and intricate of all, as four color explosion after explosion burst through the ceiling to the rocking tune of "Foreplay", one of the best songs on Boston's recent debut album. The lights and sounds were perfectly suited and the combination squeezed out many ooohs and aaahs from the audience. After all the fireworks, the lasers spelled out what appeared to be a word, and the audience twisted and craned their necks to figure out what it said. Was it intended to look like a word? Was it really a word . . . Ivan?

The first series of Laserium programs included a fair amount of electronically oriented music: a tune by Larry Fast; "Spaced" by Beaver and Krause; Emerson, Lake and Palmer's "Tank", "Hoedown", and "Abaddons Bolero"; "Timesteps" by Walter Carlos and his remake of Bach's "Suite No. 2 in B Minor"; "Gimme Shelter" by the Stones; a very nice excerpt from "Echoes" and "Set the Controls For The Heart Of The Sun" both by Pink Floyd.

Recognizing, hopefully, the potential of electronic music, Laserium has added more and more synthesized pieces to become what is now titled: "Laserium II—A Celebration of North American Music". The musical lean will perhaps be more toward synthesis and Laserium III might someday be called "A Celebration of the World Wide Electronic Realization of Music".

There could be no better medium to exhibit laser art than with synthesizer or electronically based music; rock 'n' roll is very effective here because of its core of energy . . . electronic music because of its precision.

Lasers and synthesizers both have an enticing beauty and a technical flawlessness that when experienced together, the final sum product is enhanced several hundred times. With the added accessibility of synthesizers and lasers, the dynamic duo will certainly advance by great leaps toward a more perfect fusion of this type of expression.

Laserium, combined with an increasing amount of electronic music accompaniment has truly mastered and advanced our appreciation of this technical art. ~~~~



PHOTOGRAPHS BY CHRIS AUGUST



# SYNTHESIS

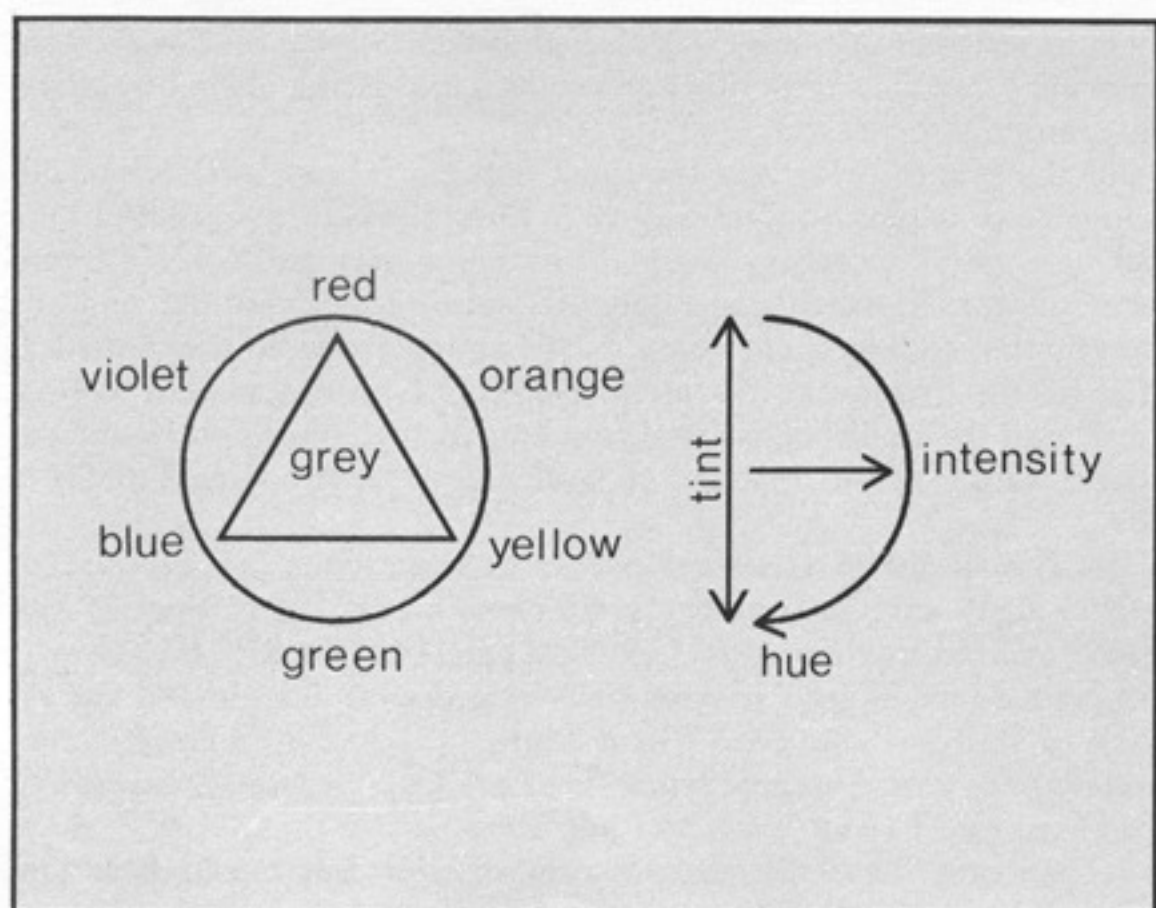

ILLUSTRATIONS BY SUE DENIM

**Color Wheel**

*with Danny Sofer*

Generating a sound is dependent upon several parameters, electronically these are: the frequency and amplitude of the waveform, (every sound has a waveform) and the shape of the waveform. Additionally there is the context within which the waveform appears. For example, a filtered sawtooth wave is more likely to appear to the brain as a trumpet or other brass instruments if it is surrounded by other sounds that might suggest an orchestral environment.

The synthesizer is unique among instruments in its ability to create endless shadings of timbre or tone color. With such a wide range of colors that are available on most synthesizers, deciding on the tone quality is an often overlooked factor in the realization of sound. The basic reason for choosing a particular timbre is its psychological effect—the emotional quality that it evokes. Sometimes this can work in reverse: a sound that is chanced upon may be singled out because of its psychological effect upon the operator, and then, will perhaps be matched with other sounds that will complement the sound's emotional quality.

Just as there are different effects resulting from the use of each color in the visual spectrum, so are there similar effects resulting from the colors in the audible spectrum.

Let us consider the color wheel. There are the primary colors: red, blue, and yellow on the perimeter of the wheel, along with the secondary colors: orange, green, violet and the infinite graduations of hue in between. Grey is in the center of the wheel; each color on the circumference may be mixed with grey to alter its intensity. This wheel has other tints formed by mixing a color with white for a lighter shade, or by darkening the color with black. In this manner, the three dimensional wheel contains all of the colors in the visible spectrum.

The "sound wheel" would contain pure harmonic waveforms at the perimeter (red-sawtooth, yellow-square, blue-sine) with secondary variances of these primary forms (pulse, triangle, and the squared sine) as well as noise at the center and modulated and other non-harmonic sounds between the center and the edge. Frequency would transpose the wheel up and down as do the tints and shades in the color wheel.

By looking at these wheels it is possible to see the relationship between visual and sonic "colors". Statements about the psychological effects of the visual colors may be extended to the audible spectrum as well: a sawtooth would be a warm aggressive timbre, a sine wave, a cool distant sound, a square wave somewhere in between, a filtered sawtooth (triangle) would be majestic and royal—as violet is the color of royalty; noise is grey, and in different shades depending upon the frequencies present—pink noise, white noise, blue noise, and so on.

What we have done is attached psychological associations to the timbral qualities of sound. To correlate those with some acoustical measurements: vibrating strings, such as those on a guitar, beat in all of the harmonic overtones simultaneously. The harmonics are the multiples of the fundamental frequency that is being generated. For example, a string vibrating at an audible frequency of A-440hz. will also vibrate at the frequencies shown in the table below:

Table of first 16 harmonics of A-440hz.

harmonic (multiple)	frequency	pitch
1	440	A
2	880	A (octave)
3	1320	E
4	1760	A (2 octaves)
5	2200	C#
6	2640	E
7	3080	G
8	3520	A (3 octaves)
9	3960	B
10	4400	C#
11	4840	D 1/4 sharp
12	5280	E
13	5720	F 1/4 sharp
14	6160	G
15	6600	G#
16	7040	A (4 octaves)

It is this particular arrangement of overtones which gives a complex waveform\* such as a sawtooth wave a discernable pitch as compared to a noise generated or modulated sound, which can be described only in highness or lowness.

A complex waveform is one which is made up of many frequencies of sine waves. Sine waves are the only pure wave form, and are the building blocks of all sound according to the method of analysis advanced by Fourier.

The sawtooth wave contains all of these frequencies, each slightly softer than the one below. The triangle wave contains them all, as well, except that each successive harmonic is much reduced in volume than the one previous, so the sound is not as bright compared to a sawtooth. A square wave contains only the odd multiples, so that while the harmonic structure is apparent, the sound is subjectively more hollow. As the pulse wave gets progressively narrower, the missing harmonics change—at 33% (□), every third harmonic is missing; at 25% (□) every fourth, etc.

The harmonic structure of a complex waveform may be examined by advancing the "Q" (sometimes called "regeneration" or "emphasis") control on a lowpass filter just below the point of oscillation and then slowly sweeping the filter frequency. The filter will pick out all of the overtones present in any sound entered into it.

As a starting point for hearing these different colored timbres, let



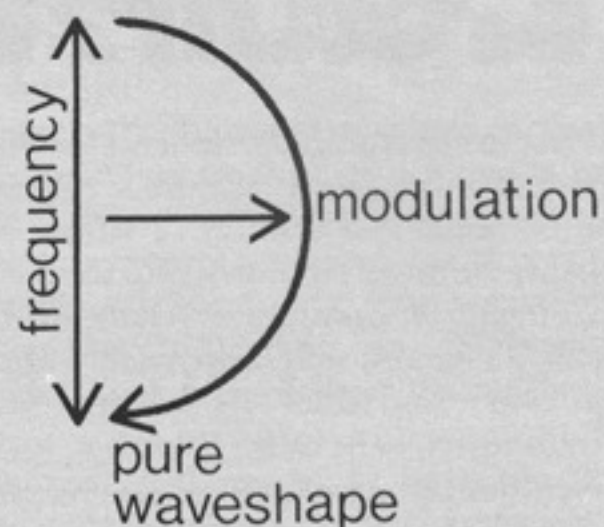
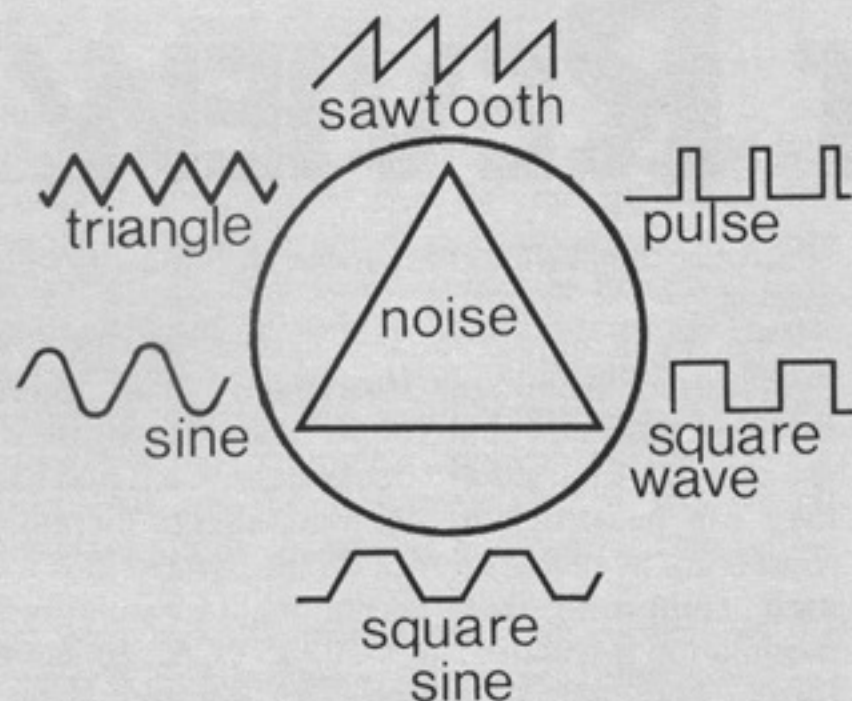

### Sound Wheel

us analyze in a gross manner, the waveshapes of some instruments of the orchestra: the stringed instruments generate a waveshape resembling a sawtooth with some harmonics emphasized because of internal resonances. The brass family generates sawtooth waves as well, except that the harmonics enter after the fundamental; this can be approximated by sweeping a lowpass filter with an envelope generator. The French Horn is unique to the brass family because the fundamental is not present in the waveform; however, the brain does reconstruct it from the harmonics that are present. The woodwind instruments with a single reed generate square waves

(clarinets and saxes) those with double reeds generate a pulse wave (bassoon and oboe) and the flute puts out something closer to a sine wave.

For more in-depth treatment:

Waveshapes and resonances

Backus, John. *The Acoustical Foundations of Music*, New York, Norton, 1969

Color Spectrum

Renner, Paul *Color, Order, and Harmony*, New York, Reinhold, 1965 ~~~~

and graphics  
and technical illustration

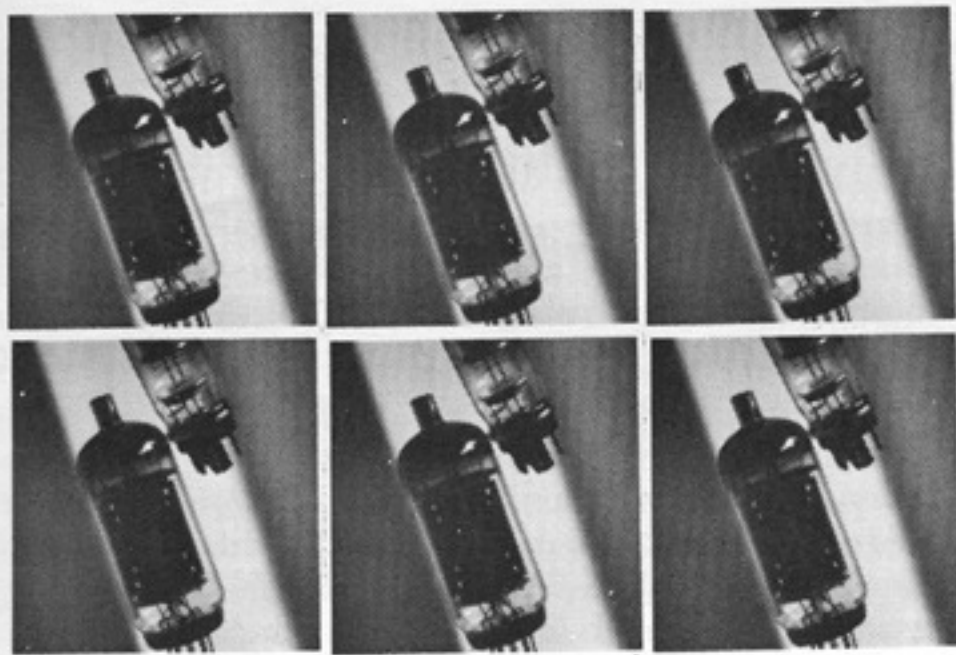

1151 macneil street  
san fernando  
california  
91340 361-6625

## THE LOS ANGELES CENTER FOR ELECTRONIC MUSIC announces THE FIRST ANNUAL LOS ANGELES ELECTRONIC MUSIC FESTIVAL

An electronic gathering of the tribes is scheduled in the month of September, in Los Angeles, to celebrate the phenomenon of Music and technology with five (5) classes of entry:

1. Tape alone
2. Tape and instruments
3. Synthesizers alone
4. Synthesizers and instruments and/or voice
5. Film with electronic scores.

A distinguished panel of electronic music composers and designers of state of the art equipment will select the entries to be performed at the festival.

Live performance entries selected will be performed by LEM, the Synthesizer Band with other guest artists and must contain appropriate scores and parts.

All entries **must** be submitted by May 14, 1977 and entrants selected will be notified by June 15, 1977.

All tapes, scores and proposals must contain the composer's name, address and phone number.

Please include a self-addressed stamped envelope if tapes and score are to be returned, otherwise all tapes will become the property of the LACEM library.

All are invited to enter, attend and participate.

**Address all entries to: LACEM FESTIVAL  
8615 Santa Monica Blvd.  
Los Angeles, Ca. 90069**



# EQUIPMENT REVIEW

If a look at the latest in electronic instruments is what you're after, you can do no better than to pay a visit to a regional or national convention of The National Association of Music Merchandisers. The most recent NAMM Convention was held in late January at the Disneyland Hotel Convention Complex in Anaheim, California with 246 exhibitors. It was the largest and most widely attended Western Market convention ever. And since synthesizers now comprise a sizeable chunk of total instrument sales, it is no surprise that almost every single major synthesizer manufacturer was represented.

Ever on the lookout for the shape of things to come, we at Synapse were able to discern on the evidence of the exhibits, three trends in synthesizer manufacture: a push toward synthesizers controlled by means other than a keyboard; a push toward systems in the \$4,000 and up range; and an explosive proliferation of mini-systems. Here we take a look at the manufacturers and their products in light of these trends.

The Ampeg Company is known mainly for their guitar amps, but this year they have come out with the "Patch 2000", a guitar synthesizer controller. The Patch 2000 is a modified Hagstrom Swede guitar whose strings and frets are specially wired to produce control voltages. The voltages are processed through the "Foot Pedal" which has controls for portamento and automatic interval latching at the fifth, or interval latching at any other manually set interval. The output of the Foot Pedal routs the voltages to a synthesizer, which of course produces the actual sounds and is not included. A three-way switch allows the Patch 2000 to function as an ordinary guitar, a synthesizer controller, or both at once. It lists for \$1,395 and is compatible with most synthesizers on the market.

Actually, Ampeg has had a previous fling with a synthesizer design innovation. In 1975 Ampeg's Computone division unveiled the "Lyricon," described as a "woodwind synthesizer." Instead of a keyboard, the controller resembles a clarinet. Wind pressure at the mouthpiece controls loudness and attack while lip pressure on the non-vibrating "reed" controls subtle changes in pitch and timbre. Unlike the Patch 2000, the Lyricon is a complete system that produces its own audio output, not by oscillators, but by direct digital generation. The "computer console" of the Lyricon allows timbral control to the point where the user can program the level and sustain of individual overtones. It lists for \$2,895.



**Left: The Lyricon woodwind synthesizer by Computone Inc. Right: The Patch 2000 guitar/synthesizer interface.**

Another "wind" synthesizer controller is the "Electronic Valve Instrument" from Steiner-Parker. Less complicated and expensive than the Lyricon, it lists for \$450. Nyle Steiner himself was at the convention performing upon this instrument. The valves are fingered like a trumpet's while a "transposition wheel" does the job of overblowing (no lip development is required to play the EVI). The transposition wheel gives it an effective range of seven octaves. The instrument also has controls for portamento, tuning, and for playing in scales other than tempered. Like the Patch 2000, the EVI is a

controller only but is compatible with most systems currently on the market.

One final non-keyboard system is the "Synare Percussion Synthesizer" from Star Instruments. This interestingly conceived machine possesses four rubber pads (surrogate drum heads) which are played with ordinary drumsticks. Each pad has three areas where they can be struck to different effect; therefore twelve different sounds are available at once on the Synare. It is a complete system in itself, comprising three oscillators, (a regular VCO, a LFO, and a modulation oscillator) a VCF, a VCA, an envelope generator, a mixer, and special controls for individualizing each pad. The inclusion of a ring modulator and both pink and white noise generators help lend the Synare its special identity as a "percussion synthesizer." The Synare retails for \$795. And this summer Star Instruments promises the "Synare II," a sophisticated advance over its predecessor.



**Left: Tom Zygmunt playing the Synare Percussion Synthesizer. Right: The E.V.I. and Micro-Con by Steiner-Parker.**

A rarely seen modular system on display at the convention was that by the Japanese manufacturer, Roland; the "Synthesizer System 700". This system has a number of features worth remarking upon. For one, the frequency range of the oscillators is an incredible 0.1 Hz-100KHZ; despite this, Roland claims the VCO's are "extremely stable." Another interesting module is the "interface." It is actually a combination pitch-to-voltage converter/envelope follower/trigger output. It will take any monophonic audio input, such as a flute, and generate one voltage proportional to the input envelope, and generate a trigger pulse when the input level exceeds a selected threshold. All of these can then be used to control the synthesizer. Another module bank, "Block 7" (the whole System 7000 consists of seven of such interchangeable blocks), comprises dual phase shifters, dual flangers, and a four input "analog switch" for instantaneous signal routing. Then there is a 36-note analog sequencer loaded with tasty features, like the control called "step time divide" which makes simple the programming of metered rhythms. The System 7000 is an intelligent product from a company known mainly for its mini-systems.

Naturally, the industry pioneer Moog had an impressive exhibit dominated by their most reasonably priced modular system, the "Synthesizer Model 35." Listing for \$5,935, Moog apparently feels the time has come for modular systems to penetrate the synthesizer market at large and not remain the exclusive property of large studios and universities. Appropriately therefore, the Model 35 is a kind of "beginner" modular system, having no modules that could be termed exotic, but possessing in quantity those modules that comprise the very heart of a synthesizer: 5 VCO's, 2 VCF's, a noise generator/filter, a fixed filter bank, 3 VCA's, 3 envelope generators, 5 "console" modules that provide for signal routing, and a five



octave keyboard. New features include "state of the art" 921 oscillators, pre-wired patching of the most common control functions, the random noise/filter module, and a power supply that can be operated worldwide.

Another Moog offering at the higher end of the price scale (\$4,495) is their new polyphonic synthesizer, the Polymoog. While the Polymoog was recently reviewed in detail in these pages, no more satisfactory demonstration of its prowess could be imagined than that afforded by an unexpected convention highlight: an unofficial, late night improvisational concert. Fifty enthralled listeners cheerfully bore the stifling confines of a small hotel room to witness some exuberant music making. Emmett Chapman on the Electric Stick and Joan Burnstein on the Polymoog led a five-person ensemble while "Musicians Guide" Magazine minicammed the whole event for posterity.

Perhaps the most economically priced modular system on the market is Steiner-Parker's "Synthasystem." It comes fully assembled for \$3,349. The module complement includes three VCO's, a VCF, a triple envelope generator, a VCA, mixer, white/pink noise generator, ring modulator, and a three octave keyboard. Also included are welcome auxiliary modules such as dual random voltage generators, VC trigger generator, phase shifter, frequency divider and sequencer. And for just a few more dollars, one can acquire useful esoterica such as dual voltage followers, a voltage processor, and a selective inverter. Needless to point out, one of the most attractive characteristics of the Synthasystem is the wide variety of available modules at economical prices.

One of the most intriguing exhibits at the convention was that by Yamaha. Although new to synthesizer design and manufacture, Yamaha is sure to have a significant impact on the market. By virtue of being a large corporation, they are able to bring considerable resources to bear upon the development and marketing of their instruments. In fact, for a number of years now they have been experimenting with various synthesizer prototypes; among them is the gigantic GX-10, Stevie Wonder's "super machine." Now, Yamaha is giving every indication of entering the synthesizer market in earnest.



PHOTOGRAPHS BY BILL MATTHIAS

### The prototype of Yamaha's new polyphonic synthesizer.

At their exhibit was the prototype of a large complex polyphonic system, as yet unnamed, that will begin production this summer. It will list for around \$6,500. This instrument was mind boggling in several respects. Although completely internally patched, it had a quantity and variety of controls far exceeding any non-modular system in the world today. It combined a large number of vivid instrumental presets with sophisticated voltage control functions (for instance VC ring modulation and VC filter resonance) that were duplicated an incredible five times over, to enable the performer to have five pre-set variable patches.

This instrument possessed a fat sound uncommon for polyphonic systems; I was told it utilizes "a completely new method" for generating a wave form for every pitch throughout its range. The touch sensitive features of the six octave keyboard were outstanding. When holding down a ten note chord one could isolate a single tone

by added volume or filtering or modulation (or whatever) with a little extra pressure on that particular key. We will see whether these favorable initial impressions are justified when the system reaches the commercial markets in the fall.

Undoubtedly the most complete line of mini-systems is that manufactured by ARP Instruments. They pioneered the concept of the internally patched and pre-set synthesizer, easily portable. Their design concepts have been widely copied by the rest of the industry. ARP, however, has capitalized on their head start by introducing mini-systems at every tier of need and budget.

At the top of the ARP line is the most sophisticated non-modular system available, the "2600." This was ARP's major breakthrough; at \$3,000 the 2600 was a studio quality synthesizer that could be afforded by the average music lover. Starting at the bottom of their instrument line and working up we have the "Little Brother," an auxiliary instrument designed to be interfaced with larger ARP systems to expand their capabilities (most ARP instruments can be connected together and controlled from one keyboard). Then there is the "Axxe," their smallest complete system; the "Pro-Soloist" an entirely pre-set synthesizer with a touch-sensitive keyboard, designed to reproduce instrumental timbres; the "Odyssey," the world's standard mini-system and the most popular in terms of sales, the "String Ensemble," which was the first string synthesizer, and the new polyphonic "Omni," which we recently reviewed.

The ARP line continues to branch out. In a marketing move designed to undercut the appeal of more expensive digital sequencers, they now manufacture a 16 note analog sequencer (\$795). The sequencer has an internal clock and a variety of control functions which can be externally patched and interfaced with another synthesizer. Also, ARP has recently unveiled the "Music Minus Noise Mixer." This eight input unit has a special feature that ARP terms a "dynamic noise filter," but which is really a noise gate. It works thusly: when the input level of any given band-width falls below a certain threshold the filter gate closes. The result is a reduction of hiss during rests or quiet passages.

Another fairly complete line of mini-systems is the one offered by Korg. At the top of their line are two polyphonic systems. The first is the "Polyphonic Ensemble 'P' "; its pre-sets are mainly designed to duplicate the percussive characteristics of the piano and harpsichord, as well as the timbres of organ, brass and reeds. Synthesizer controls on this instrument include equalization, a VCF, an ASD, portamento, vibrato, and a waveform bank. It is a spartan device in terms of features when compared to other polyphonic systems, but it has the happy distinction of being the lowest priced of all (\$1,095). The "Polyphonic Ensemble 'S' " (\$1,295) is a string synthesizer that includes chorus, organ, and brass pre-sets and a master phasing control. Another of their systems, the "True Duophonic Synthesizer" (\$1,025) is unique because it is a two-voiced system where every control feature is literally duplicated. It has two VCO's, two hi-pass lo-pass VCF's, two ADSR's, well, you get the idea. (The only other two-voiced systems available today are the Steiner-Parker Synthicon II; the "Cat" from Octave Electronics; the ARP 2600, and Oberheim's "Two-Voice." Only the Korg and Oberheim systems offer dual controls. Completing the Korg line is the "Twin VCO Synthesizer" (\$595), and it's slightly more elaborate cousin, the Twin VCO "Instant Set" Synthesizer, (\$695).

To return to Yamaha for a moment, the one synthesizer they have actually marketed is a mini-system called the "SY-2." As bright as Yamaha is, the SY-2 shows they still have a few things yet to learn. For one thing, the pitch bend control, incredibly, is not manual, but is automatic. The direction of the slide is always up, the interval traveled is always a semi-tone, and the rate is pre-set and non-variable. The effect is utterly mechanical and without charm. However, for a mini-system the SY-2 thinks big. No less than 28 pre-set instrumental voices are offered, all of which are modifiable by the regular complement of synthesizer controls, including fully separate lo and hi-pass filters and, similar to the ARP "Pro-Soloist," a touch-sensitive keyboard. The SY-2 lists for \$995.

One final mini-system of note we spotted at the convention is the "Cat" from Octave Electronics. Its features are designed to make it

please turn to page 39

— Tom Davey



## Roger Powell & Todd Rundgren from page 23

We're here now. This is what's happening. There may be more acceptance of it on a *more* general level, yes, but I think that most people are unaware of how much it's in their lives already.

**Todd:** I don't think the objective is to see how many people can lay their hands on one of these instruments. For instance, what good is this technological advance going to do if all it does is bring these technologically facilitated, musical advances, down to people who take them so lightly that essentially it was never worth it. It may be a while before the performer that really takes the greatest advantage of this appears. You know, it may be Roger, it may not be Roger. I mean, hopefully it's Roger since he's got the first one, but the idea is that a lot of the people who would get the most out of this instrument, have the kind of personality where they wouldn't want to get up there with the instrument and stand there and play and boogie around. A lot of musicians use their instruments as something to hide behind as well as something to express themselves with. There are very few of them who will get out there and give a physical performance that warrants having that flexibility. So in a way, maybe it's not something for everybody. Maybe it's only something for a very few people who are going to exploit the possibilities of it. Maybe it is for everybody in some form, but the level on which Roger's instrument functions is way beyond the capabilities of most keyboard players to operate it even now, let alone to play it and dance around at the same time. It may be quite a while before the synthesizer as a legitimate performing instrument becomes something as common as a guitar player or a drummer.

**Synapse:** *What people in the field right now do you respect most in terms of electronic music?*

**Todd:** I draw a big blank there. There's a real war going on out there about labels, and all kinds of shit. You know, I don't even think about what's electronic music and what isn't electronic music, but there are some people out there who are just looking for anything that has the slightest electronic buzz to it so they can shoot at it. It's part of a 1984 consciousness. It's like, is technology taking over the world and are we going to *have* to listen to these synthesizers? Are we going to be forced? You know, like everybody that's born is going to have a jack installed in their head and have to plug into one of these things. So there's a whole battle of shit going on, and it's like Roger said, it became electronic as soon as anything to do with electronics touched the instrument. When it gets down to that, the only non-electronic music is probably being played at Bar Mitzvah's and things like that, with a clarinet and an accordion.

**Roger:** Yeah, but even then they have a Shure vocal master hooked into it.

**Synapse:** *So in other words, your philosophy is sort of that you're doing loud speaker music, so it is electronic.*

**Todd:** Yeah, everything. For instance, in our performance, anything that comes off the stage has been electrified somehow.

**Roger:** It's been electrified in many cases to make it sound acoustic. I mean, you have the power these days to create ambience with digital delays and other sophisticated devices. Well, what is that ambience? It's the total of the acoustic environment plus that other indeterminable factor of the human emotion that happens to be vibrating at that time in that place. There's more than just what you can measure on the oscilloscope.

**Todd:** I think in some ways we don't consider ourselves, hey, an electronic band. I think what we're trying to do has a lot to do with technology but that's not what we're trying to accomplish. You know, we're not trying to establish a new level of technology or become associated with a new level of technology. We want to be associated with a certain sensibility about tools essentially, electronics being one of them. And the tools and facilities that are available to us on a number of levels; not only in the field of electronics but in the field of, for instance, psychic energy and things like that. They're just more tools and we want to make the most efficient use of those tools. We're not trying to become Utopia, the synthesizer band. We're trying to just be Utopia, whatever we stand for. I think in some ways it has to do with an attitude about these things that we're using. We don't use them in ignorance or fear, nor do we try to make them something that they're not. Ultimately, all the gadgets that we use are not responsible for our creative inspiration. We still have to come up with that ourselves.

**Synapse:** *Do you shape your music in any way towards your audience or is it more a personal thing?*

**Todd:** There's a lot of both aspects. We have to satisfy ourselves, we have to like our own records. And at the same time the whole reason why we have the band and the reason we're trying to accomplish these things is because we feel a certain responsibility to our audience. In some ways we have to almost be elected by the people, which is our audience. In other words, they come and see us and they support what we do and they pay for records, and they pay for concert tickets and we take the money and with that money we're supposed to express something that as individuals they wouldn't have the facilities to express, so it's the same thing as being elected officials of the government. It's a whole phenomenon. Everyone is trying to get elected to this position.

**Roger:** They all have the greatest platforms.

**Todd:** Our platform is humanization of technology and just humanization of humans . . . like take the big mess that's the world that we live in and without getting too crazed, dismantle what needs to be dismantled and construct what needs to be constructed but

not stand around bitching all the time. "What a mess this is, I'm so frustrated."

**Roger:** Or "why bother if it's going to blow up in a week."

**Todd:** We figure if it's going to blow up in a week we might as well be doing something, so we don't have to worry about it blowing up . . . you know, doing nothing, all you do is just sit around and think about it blowing up so we'll delude ourselves and we'll pretend that it all really matters and we'll go out and bust our asses and we'll work for ourselves.

**Synapse:** *Do you have any concrete plans for the future with the group?*

**Todd:** Well, we're just touring a lot and we've got another album to do and after that there will probably be a lot of individual records coming out with different members of the band, once we get time. That's mostly what we're up to. We haven't even gotten on the road yet with this show so once we get on it, we'll be on it for a while.

**Synapse:** *Do you think that electronic music will in some way become more popular, with groups like Utopia doing a lot of concerts for popular audiences? Do you think this will help the avant-garde composers who are doing electronic music and maybe given them a little boost?*

**Todd:** In some ways. I don't even know what way music is going or where it's supposed to be. I figure there's a place for all kinds of music. I personally have a big belief in disposable music. I think that music should not be candy but in general should not be crystallized. A lot of music that's written is only temporarily relevant. And some of it is so temporarily relevant that it becomes evocative past the point that it is relevant. That's how music lasts. For instance most of the classical music that we listen to is more evocative than relevant. It's not the background music to your life style. It's usually disco music. That's the background music of the life style nowadays or, it's the kind of music that most people are hearing as they go throughout the day. Anything a composer is doing will be relevant for a short time, and may become relevant again.

**Roger:** I think it's probably helped them somewhat because now Stockhausen is signed to Chrysalis Records. I think it brings up a lot of implications about artists who are achieving recognition in their own time, and fame and money, which didn't happen before.

**Todd:** It's the whole question of commercial art. There was a time when a lot of what artists did, they did out of what they considered moral responsibility and that was because if you didn't have a patron you didn't operate. It was like you couldn't hope to be a commercial success. A lot of artists just had to hope for the moral satisfaction that it gave them. Unless you had a patron you were only doing it for the fun of it, you know, for art's sake. It's only recently that it's become like a doctor or a lawyer. You can actually set out to become a successful commercial musician, you know, and how



much art is involved in that? Is that art or is that craft? It's more a craft or a manufacturing skill than it is art. Can anything that becomes commercially accepted be considered art? You know, in some ways, I don't even know that what we do as it relates to an audience is art. I think we consider it more communication than art. And what we're trying to do and what we're trying to accomplish mostly is communication and not artistic milestones.

**Synapse:** *Do you think of it as theater?*

**Todd:** I guess. I guess in some ways it could be considered that. And it's not that we don't hit points that are not artistic, but for instance we can't operate this show without a certain amount of commercial return. We need to pay the electric bill and all that other stuff so in some ways it's art and in some ways it's not art. In some ways the concept is more art than the actual

practice of it, and that can be said about just about anything that becomes commercially successful. So what is art? What do these people really want? What is an avant-garde composer really looking for? Is he looking for recognition and success or is he trying to discover something in music.

**Roger:** I found out from the time I got interested in things other than classical music that I wanted to be an avant-garde composer. That was really exciting to consider yourself to be on the forefront of musical frontiers and so forth, but I found in my course of beginning that trek that academia more or less prevented me from enjoying that. At the time I was going to music school, synthesizers weren't very prevalent and they didn't want to hear about it at all. So that sort of discouraged me and then I also discovered that a lot of these tools that I wanted to use were very expensive and you've either got to have a patron,

benefactor, inheritance, or work your ass off.

**Todd:** Or work in education.

**Roger:** Even there, there are drawbacks to that because you've got to share with a lot of other people and you can't get in when you need to do something. I found that if I assiduously applied myself to my craft, it would enable me to have access to some of these tools and that was sort of what motivated me to get into this end of the business and I still hope that at some point . . . well I have, I've established a studio in my house which is exclusively devoted to experimental electronic music. I just hope that I can support my technology habit; but maybe at some point I'll get into the ultimate technology of rearranging my brain so I won't even need the physical manifestation of the tools. I'll just take a piano and make it sound like 40 synthesizers. ~~~

## EQUIPMENT REVIEW

competitive with the ARP "Odyssey" and the "Minimoog" at a

somewhat lower price. A few of the things the Cat has that the others do not includes: a sub-octave division of the two oscillators to give the aural impression of four; simultaneous mixing of four wave forms; a lo-pass VCF that can be used as a sine wave oscillator; and a two-voice keyboard. \$599 it is worth checking. ~~~

## LISTINGS

from page 40

**Otari Corporation**  
981 Industrial Road  
San Carlos, California 94070  
(415) 593-1648

**Scientific Audio Electronics Inc.**  
P. O. Box 60271, Terminal Annex  
Los Angeles, Calif. 90060

**Scotch/3m Magnetic Audio/Video  
Products Division**  
3 M Center, Saint Paul, Minn. 55101  
**Shure Brothers Inc.**  
222 Hartrey Avenue, Evanston, Ill. 60204  
**Scully Recording Instruments**  
475 Ellis St.  
Mountain View, Calif. 94943

**TDK Electronics Corporation**  
755 Eastgate Blvd., Garden City, N.Y. 11530  
**TEAC Corporation of America**  
7733 Telegraph Road  
Montebello, Calif. 90640  
**Telex Communications Inc.**  
9600 Aldrich Avenue South  
Minneapolis, Minn. 55420

## POP WORKS

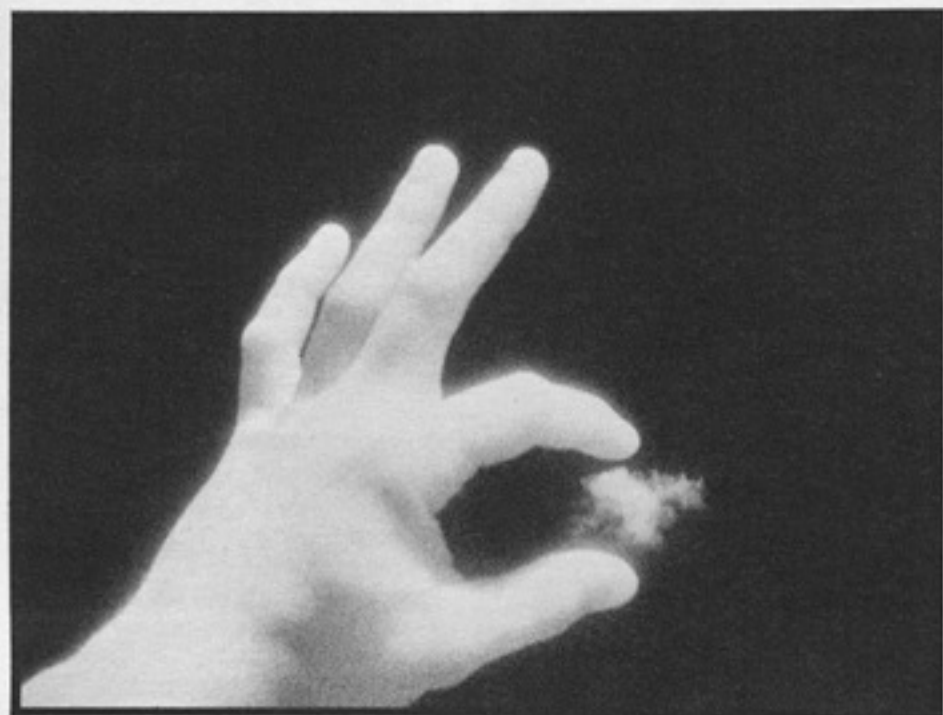

**fine arts & other fine  
PHOTOGRAPHY  
bill matthias - los angeles  
213/986-3951**

# Lem

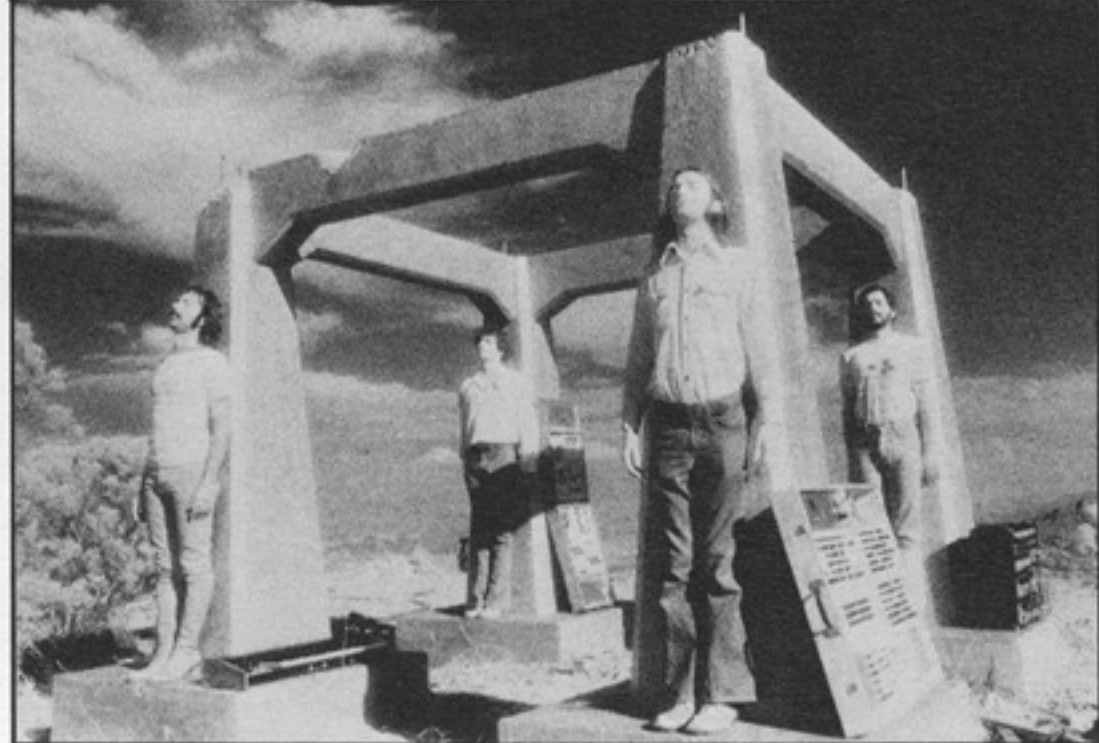

**the synthesizer band**

moldar productions (213) 463-8772  
8615 santa monica blvd., l.a. ca. 90069



# LISTINGS

In order to provide a comprehensive service to the reader, we have enlarged the scope of our Listings section to include these headings: Sound Reproduction, Accessories, in addition to Synthesizer Manufacturers, Consultants and Schools. Synapse invites you to use the Listings as a resource to support your activities and asks that you forward the name and address of any company that you feel we have overlooked.

## Synthesizers

### Manufacturers:

**Advanced Tools for the Arts**  
P. O. Box 825  
Tempe, Ariz. 85281

**Alan Labs**  
Box 434, Van Nuys, Calif. 91408

**Aries Music Inc.**  
P. O. Box 3065, Salem, Mass. 01970

**ARP Instruments**  
320 Needham St., Newton, Mass. 02164

**John Blacet\***  
4019 Chico Ave., Santa Rosa, Calif. 95401

**Buchla**  
Box 5051, Berkeley, Calif. 94705

**CFR Associates\***  
Box F, Newton, N.H. 03858

**Computone Inc./Lyricon**  
P. O. Box 433, Norwell, Mass. 02061

**Concert Company\*\***  
3318 Platt Avenue, Lynnwood, Calif. 90262

**Davel**  
Box 279, Verdugo City, Calif. 91246

**D.B.L. Electronics**  
502 Sherman, Canton, Mass. 02021

**Dennis (Electronic Music Components)**  
2130 Metcalf, Honolulu, Hawaii 96822

**Electron Farm/Harvest**  
Gregory Kramer  
135 W. Broadway, New York, N.Y. 10013

**Electronic Music Laboratories**  
P. O. Box H, Vernon, Conn. 06066

**Electronic Music Studios (London) Ltd.**  
277 Putney Bridge Road, London,  
England SW152PT

**E-mu Systems**  
3046 Scott Blvd.  
Santa Clara, Calif. 95050

**Farfisa**  
1330 Mark St., Elk Grove Village, Ill. 60007

**Gentle Electric**  
119 Brainerd Rd., No. 15, Allston,  
Mass. 02134 (617)731-4844

**Ionic Industries**  
128 James St., Morristown, NJ 07960

**Korg/Univox/Merson**  
75 Frost St., Westbury, N.Y. 11590

**M M Electronics, French's Mill**  
French's Rd., Cambridge, England CB4 3NP

**Moog/Norlin**  
7373 North Cicero Ave.  
Lincolnwood, Ill. 90646  
Customer Service: Box 131, Academy St.  
Williamsville, N.Y. 14221

**Musitronics Corporation, Sound Lab 10**  
Rosemont, N.J. 08556

**Oberheim Electronics**  
1549 Ninth St., Santa Monica, Calif. 90401

**Octave Electronics Inc.**  
32-73 Steinway St.  
Long Island City, N.Y. 11103

**Octron**  
1346 Bayport Avenue  
San Carlos, Calif. 94070

**Omniphon**  
Box 166, Churchill Rd., Mason, N.H. 03048

**Oznie Process Electronics**  
Box 7, Centerville, Penn. 16404

**PAIA\*, Box 14359**  
Oklahoma City, Okla. 73114

**Polyfusion Inc.**  
160 Sugg Road, Buffalo, N.Y. 14225

**Roland**  
2925 South Vail St.  
Los Angeles, Calif. 90040

**Sequential Circuits Company**  
7150 Rainbow Drive No. 7  
San Jose, Calif. 95129

**Serge Modular Music**  
1107 1/2 N. Western Ave.  
Hollywood, Calif. 90029

**Star Instruments Inc.**  
Box 71, Stafford Springs, Conn. 06076

**Steiner-Parker**  
2258 South, 2700 West  
Salt Lake City, Utah 84119

**Strider Systems**  
P. O. Box 2934, Norman, Okla. 73070

**Syn-Cordian**  
32-73 Steinway St.  
Long Island City, New York 11103

**Syn-Key, 114 W. Hintz Road**  
Wheeling, Ill. 60090

**THINC-Technical Hardware Inc.**  
P. O. Box 3609, Fullerton, Calif. 92634

**VAKO Synthesizers Inc.**  
4651 62nd Avenue North  
Saint Petersburg, Florida 33565

**Yamaha International**  
Box 6600, Buena Park, Calif. 90620

**360 Systems**  
2825 Hyans Street, Los Angeles, Calif. 90026

### Note:

\* manufacturer makes kits only  
\*\* manufacturer makes both kits  
and finished product

### Consultants:

**Beckman & Associates**  
2117 Yates Ave., Los Angeles, Calif. 90040

**Michael J. Boddicker**  
(213) 985-0010

**Boston Experimental Electronic Music Projects, Robert Ceely**  
33 Elm St., Brookline, Mass. 02146  
(617) 731-3785

**Different Fur Music**  
John Vieira  
3470 19th St., San Francisco, Calif. 94110  
(415) 863-WAVE

**Disco Tech Musical Electronics**  
1428 N. Farwell, Milwaukee, Wisc. 53202  
(414) 271-9291

**DS Music**  
811 Franklin St., Santa Monica, Calif. 90403  
(213) 463-8772

**EMSA (Electronic Music Studios of America, Inc.)**  
269 Locust St., Northampton, Mass. 01060  
(413) 586-3777

**Entropy West Electronics**  
Eric Valinsky  
1242 Harvard St., Santa Monica, Calif. 90404  
(213) 828-0389

**Electronic Music Studio**  
Dwight D. Gatwood, Director  
University of Tenn., Martin, Tenn. 38238  
(901) 584-7402, 587-2281

**Michael Gilbert**  
88 Beacon Street, No. 14  
Somerville, Mass. 02143

**Lectron Music Lab**  
Box 1594  
Hollywood, Calif. 90028

**Stan Levine**  
13508 Debell St., Pacoima, Calif. 91331  
(213) 899-7223

**Patchwork Sound**  
Jack Howe  
14759 Hesby St., Sherman Oaks, Calif. 91403

**People's Computer Company**  
P. O. Box 310  
Menlo Park, Calif. 94025

**Pi Corporation**  
1741 East 24th St., Cleveland, Ohio 44114  
(216) 781-2207

**Ron Rivera**  
48 Brighton Avenue, No. 11  
Allston, Mass. 02134

**Dr. Philip Springer**  
Box 1174, Pacific Palisades, Calif. 90272  
(213) 454-5275

**Star Track Recording Studio**  
8615 Santa Monica Blvd.  
Los Angeles, Calif. 90069 (213) 855-1171

**Carter Thomas**  
Manpel Road, Spring Glen,  
N.Y. 12483 (914) 647-9121

**TNY Music & Engineering**  
Route 4, Defreestville, N.Y. 12144  
(518) 283-2837, 283-2899

### Schools:

**Boston School of Electronic Music**  
326 Dartmouth Ave., Boston, Mass. 02116  
(617) 261-1634

**Con Tempo Music Guild**  
13273 Ventura Blvd.  
Studio City, California 91604 (213) 784-8271

**James D. Craig Music**  
511 Cedar St., Allentown, Penn. 18102  
(215) 437-4743

**Dick Grove Music Workshops**  
12754 Ventura Blvd., Ste. 2  
Studio City, Calif. 91604

**Los Angeles Center for Electronic Music**  
8615 Santa Monica Blvd.  
Los Angeles, Calif. 90069 (213) 652-7655  
463-8772

**Sound Arts**  
2825 Hyans St.  
Los Angeles, Calif. 90026 (213) 487-5148

**Sherwood Oaks Experimental College**  
6353 Hollywood Blvd.  
Hollywood, Calif. 90028 (213) 462-0669

## Sound Products & Accessories

**Alembic**  
P. O. Box 759, Sebastopol, Calif. 95472  
(707) 823-8579

**E Bow/Heet Sound Products**  
611 Ducommun St.  
Los Angeles, Calif. 90012 (213) 687-9946

**Electro-Voice**  
674 Cecil St.  
Buchanan, Mich. 49107

**Eventide Clockworks, Inc.**  
265 West 54th St., New York, N.Y. 10019  
(212) 581-9290

**FRAP**  
Box 40097  
San Francisco, Calif. 94140  
(415) 824-2223

**FROGG (Design Engineering Labs Inc.)**  
4121 Redwood Ave.  
Los Angeles, Calif. 90066 (213) 823-8220

**Hammond**  
4200 Diversey, Chicago, Ill. 60639

**Heil Sound Systems**  
Heil Industrial Blvd., Marissa, Ill. 62257

**Infitheatre Inc.**  
4990 Mass Ave., Indianapolis, Ind. 46218

**Mellotron/Dallas Music Industries**  
301 Island Road, Mahwah, N.J. 07430  
(201) 327-6300

**Morley Electronics**  
2301 West Victory Blvd.  
Burbank, Calif. 91506 (213) 843-7122

**Rothchild Musical Instruments**  
(distributor Furman and Alembic products)  
65 McCoppin St.  
San Francisco, Calif. 94103 (415) 626-2260

**TAPCO**  
405 Howell Way, Edmonds, Wash. 98020  
(206) 775-4411

**Wasatch Music Systems**  
P. O. Box 9175  
Salt Lake City, Utah 84109

## Sound Recording

**Ampex**  
401 Broadway, Redwood City, Calif. 94063  
(415) 367-4544

**dbx Incorporated**  
296 Newton St., Waltham, Mass. 02154  
(617) 899-8090

**Dokorder**  
5430 Rosecrans Ave.  
Lawndale, Calif. 90260

**Dolby Laboratories Inc.**  
731 Sansome St.  
San Francisco, Calif. 94111  
(415) 392-0300

**Furman Sound**  
60 Brady St., San Francisco, Calif. 94103  
(415) 863-0097

**Magnetic Reference Laboratory Inc.**  
229 Polaris Avenue, Suite 4  
Mountain View, Calif. 94043  
(415) 965-8187

**Maxell Corporation of America**  
130 West Commercial Ave.  
Moonachie, New Jersey 07074

**Orban/Parasound**  
680 Beach St., San Francisco, Calif. 94109  
(415) 673-4544

please turn to page 39

### CLASSIFIED ADS

20 WORDS FOR \$2.00

TO: SYNAPSE

CLASSIFIED ADS

2829 HYANS STREET

LOS ANGELES, CALIF. 90026

### SYNTHESIZER

Programming

Consulting

Tracks

... and Music

MICHAEL GILBERT

88 Beacon Street #14

Somerville, Mass. 02143

(617) 661-3332

Serge Equipment—about 10 panels, 170" of superb Tcherep-nin artistry plus a few modules of my own design (four seven-bit binary keyboards), attractively gift boxed in a rugged carrying case, finished in black imitation vinyl alligator skin. 7 oscillators, 2 sequencers, 6 gates, 2 ring modulators etc. . . .  
(212) 966-9769

FOR SALE: 2 EMS Synthi A Mk.I w/PVC, DKI, many custom modifications, pedals, accessories. Both units recently recalibrated by U.S. distributor. \$2195 all-will consider separate (714) 444-0189 Tim Best 2031 Valley View Blvd., El Cajon, Calif. 92021.

I have a Serge Modular System with VCO, Low, High, and Band Pass VCF, Phaser, Reverb, two Positive and Negative Slews, Ring, VCA, Mike Preamp, and Mixer in Custom-built case. Would like to trade for Arp String Ensemble or other String Synthesizer. Chris (213) 469-0591.

### Electronic Music Schools and Programs

Please send a description of your courses, services, philosophies, and equipment status to Synapse. Be part of our Electronic Music Education listing.



# what's a synthesizer?

the electronic music magazine  
**Synapse**

# subscribe!

please use the attached postage-paid  
envelope for your subscription order



BULK RATE  
U. S. POSTAGE  
PAID  
No. Hollywood, CA  
PERMIT NO. 456

THIRD CLASS

# After 100 gold records, thousands of concerts and millions of miles, only the strong survive.



1. ARP ODYSSEY. Fast, powerful and funky, like Rufus. Classic ARP human engineering. 2. ARP PRO SOLOIST. "The finest lead line synthesizer ever made," says Mike Mandell of the Larry Coryell band. Over 30 pre-set voices and incredible touch sensitive keyboard. 3. ARP AXXE. Popular, inexpensive. The basic variable synthesizer. Herbie Hancock says, "the AXXE is the place to start." 4. ARP STRING ENSEMBLE. Lush, authentic strings. Plus full brass, electric piano and clavinet when combined with the AXXE. Listen to the Jefferson Starship. 5. ARP 2600. "The synthesizer standard," says Pete Townshend. "Beautiful," says Stevie Wonder. 6. ARP EXPLORER. The fattest soulful sound around. Fast like a pre-set yet flexible like a variable. 7. ARP LITTLE BROTHER. A synthesizer expander with guts. Its extra voice comes in deep and low-down.

World's leading manufacturer of electronic music synthesizers.



ARP Instruments, Inc., 320 Needham St., Newton, Mass. 02164 (617) 965-9700/Canadian Distributor: MCH, Richmond, B.C. (604) 273-7251