

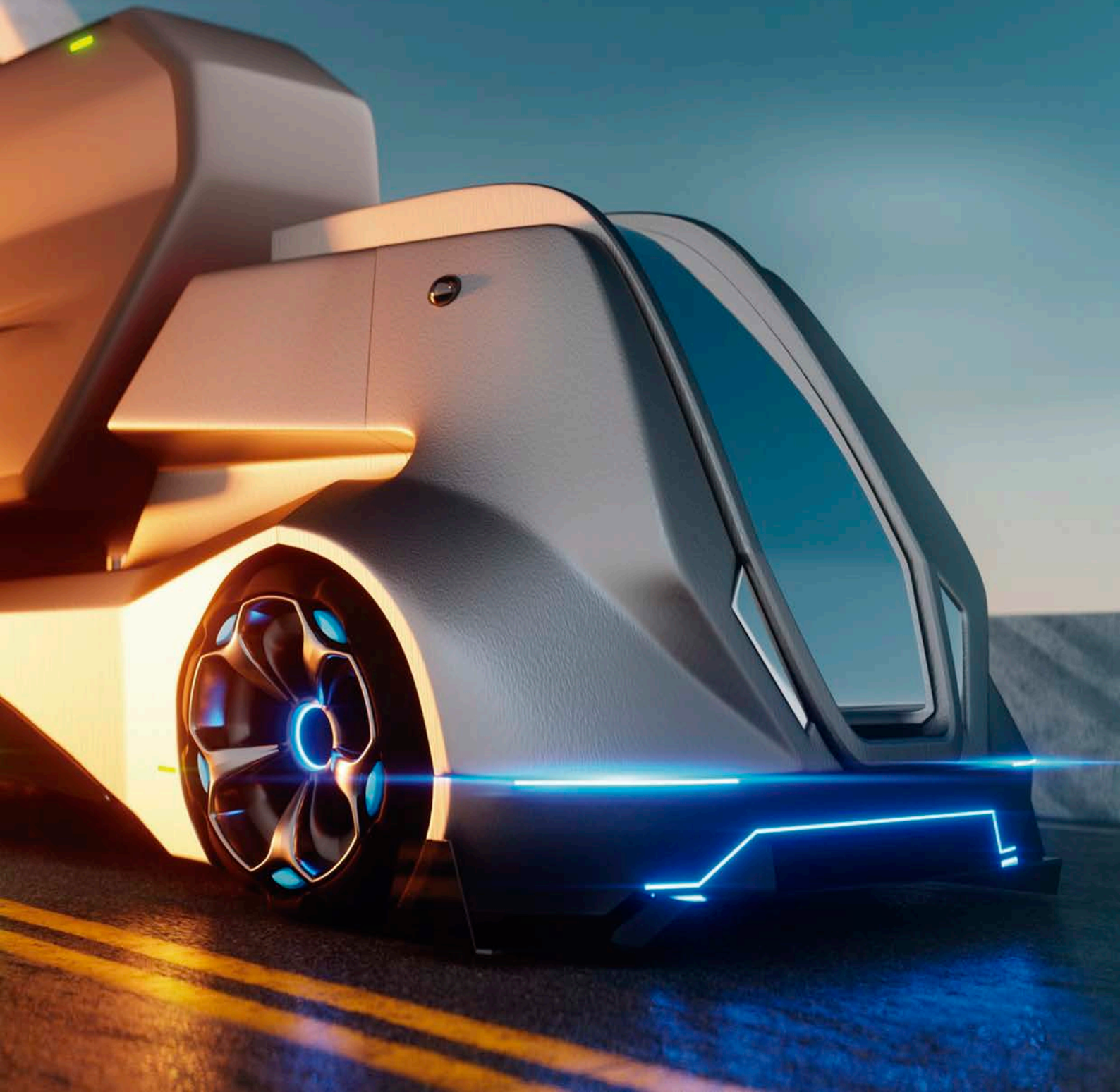

ADAICO®

Truck Systems Worldwide



PICTOGRAMAS / PICTOGRAMS / PICTOGRAMMES

ACABADO / SURFACE TREATMENT / TRAITEMENT DE SURFACE

Galv GALVANIZADO GALVANIZED GALVANISÉ	MEC MECANIZADO MACHINING MÉCANISÉ	Cr CROMADO CHROMATED CHROMÉ	Anod ANODIZADO ANODIZED ANODISÉ	 PINTADO COATED PEINT	 MATE MATT MAT	 BRILLO POLISHED BRILLANT
Zn CINCADO ZINC PLATED ZINGUÉ	KTL CATAFÓRESIS CATAPHORESIS CATAPHORÈSE	MMec MECANIZADO MECÁNICO MECHANICAL MACHINING MACHANISCHE BEARBEITUNG				

CABINA / CABIN / CABINE

 ESTRECHA NARROW ÉTROITE	 ALTA HIGH HAUTE
 ANCHA WIDE LONGUE	

CIERRE / LOCK / FERMETURE

1 1 UÑA 1 POCKET 1 GÂCHE	3 LOCK 3 CIERRES 3 LOCKS 3 SERRURES	 MANILLA HANDLE POIGNÉE	 CIERRE COMPLETO COMPLETE LOCK FERMET. COMPLÈTE	 CIERRE LOCK FERMETURE
 CREMONA KEEPER GÂCHE	 ENGANCHE HOOK VERROUILLAGE	 LEVA CAM PÈNE	 CIERRE EMPOTRADO INTERIOR LOCK FERMETURE ENCASTRÉE	
 PUENTE SUPPORT GUIDE DE TUBE	 CIERRE SUPERKIT SUPERKIT LOCK FERMETURE SUPERKIT			

MATERIAL / MATERIAL / MATERIAL

STEEL ACERO STEEL ACIER	PVC PVC PVC PVC	PP POLIPROPILENO POLYPROPYLENE POLYPROPYLENE	PE POLIETILENO POLYETHYLENE POLYÉTHYLÈNE	CCA CCA CCA CCA	PMA METACRILATO METHACRYLATE MÉTACRYLATE	Ny NYLON NYLON NYLON
TPE PU TPE/PU TPE/PU TPE/PU	GRP POLIÉSTER POLYESTER POLYESTER	INOX ACERO INOX STAINLESS STEEL ACIER INOX	Forged FORJA FORGED STEEL ACIER FORGÉ	Cu-Zn LATÓN BRASS LAITON	INOX ALUMINIO/INOX ALUMINIUM/INOX ALUMINIUM/INOX	ALUMINIO ALUMINIO/ALUMINIO ALUMINIUM/ALUMINIUM ALUMINIUM/ALUMINIUM
 PLÁSTICO PLASTIC PLASTIQUE	 GOMA RUBBER CAOUTCHOUC	 MADERA WOOD BOIS	 ALUMINIO ALUMINIUM ALUMINIUM	Zamak ZAMAK ZAMAK ZAMAK	ABS PMMA ABS/PMMA/PVC ABS/PMMA/PVC ABS/PMMA/PVC	STEEL ALUMINIO Y ACERO ALUMINIUM AND STEEL ALUMINIUM ET ACIER
STEEL ACERO/ACERO STEEL/STEEL ACIER/ACIER	EPDM EPDM EPDM EPDM	ABS ABS ABS ABS	AZM ALUMINIO/ZINC/ MAGNESIO	INOX INOX INOX/INOX INOX/INOX INOX/INOX	PVC Cu-Zn LATÓN/PVC BRASS/PVC LAITON/PVC	SILICON SILICONA SILICON SILICON

POSICIÓN / POSITION / POSITION

 VERTICAL VERTICAL VERTICAL	 HORIZONTAL HORIZONTAL HORIZONTAL	 HOR-VER HOR-VER HOR-VER	 SUPERIOR-DCH UP-RIGHT SUPÉRIEUR-DR	 SUPERIOR-IZQ UP-LEFT SUPÉRIEUR-GA	 INFERIOR-IZQ DOWN-LEFT INFÉRIEUR-GA	 INFERIOR-DCH DOWN-RIGHT INFÉRIEUR-DR
 IZQUIERDO LEFT GAUCHE	 SUPERIOR UP SUPÉRIEUR	 DERECHO RIGHT DROIT	 IZQ/DRCHO LEFT/RIGHT GAUCHE/DROIT	 INFERIOR DOWN INFÉRIEUR	 TRASERO-DCH REAR-RIGHT ARRIÈRE-DROITE	 LATERAL SIDE LATÉRAL
 TRASERO-IZQ REAR-LEFT ARRIÈRE-GAUCHE	 DELANTERO FRONT AVANT	 TRASERO REAR ARRIÈRE				

ILUMINACIÓN / LIGHTING / ÉCLAIRAGE

 FRENO STOP LIGHT FEU STOP	 ANTINIEBLA FOG LIGHT ANTIBROUILLARD	 ANTINIEBLA TRAS. REAR FOG LIGHT ANTIBROUILL. AR.	 FARO HEADLAMP PHARE	 PILOTO DELANTERO FRONT INDICATOR FEU AVANT	 PILOTO LATERAL SIDE LAMP FEU LATÉRAL	 LUZ MATRÍCULA NUMBERPLATE LIGHT ECL. D'IMMATICULATION
 PIL. POSICIÓN SIDE MARKER FEU LATERAL	 PILOTO TRASERO TAIL LAMP REAR FEU ARRIÈRE	 LUZ TRASERA TAIL LIGHT FEU ARRIÈRE	 LUZ LATERAL SIDE LAMP FEU DE POSITION	 LUZ DE GALIBO POSITION LIGHT FEU LATÉRALE	 REFLECTANTE REFLECTANT RÉFLÉCHISSANTE	 INTERMITENTE DIRECTION INDICATOR LIGHT FEU INDICATEUR DE DIRECTION
 PIL. MARCHA ATRÁS REVERSING LAMP FEU MARCHÉ ARRIÈRE	 MARCHA ATRÁS REVERSING LAMP FEU MARCHÉ ARRIÈRE	 LUZ MATRÍCULA NUMBERPLATE LIGHT ÉCLAIRAGE D'IMMATICULATION	 CON PORTALÁMPARA WITH BULB HOLDER AVEC PORTE LAMPE	 TULIPA LENS CACHOBON		

OTROS / OTHERS / AUTRES

 RÍGIDO RIGID RIGIDE	 CISTERNA TANKER CITERNE	 LONA CURTAIN BÂCHE	150 kg FUERZA EN KG STRENGTH IN KG FORCE EN KG	1.250 daN FUERZA EN DAN STRENGTH IN DAN FORCE EN DAN	600 N FUERZA EN N STRENGTH EN N FORCE EN N	 AMORTIGUADOR GAS SPRING RESSORT À GAZ
 CON LLAVE WITH KEY AVEC CLÉ	 VISERA SUN VISOR VISIÈRE	 ABRAZADERA PILLAR POCKET GOUSSET	 KIT SOPORTES SUPPORTS KIT JEU SUPPORTS	 CUÑA PILLAR PIN PIED RANCHER	R MANO DERECHA RIGHT HAND MAIN DROITE	L MANO IZQUIERDA LEFT HAND MAIN GAUCHE
 ESTANTE SHELF ÉTAGÈRE	 CABLE CABLE CÂBLE	 TURISMO Y 4X4 TOURISM AND 4X4 TOURISME ET 4X4	 V.I. Y CAMIÓN LCV AND TRUCK V.I. ET POIDS LOURD	 CRISTAL+CARCASA GLASS+HOUSING GLACE+BOITIER	 CRISTAL+SOPORTE GLASS+HOLDER GLACE+SUPPORT	V Class COMPLETO CLASE V CLOMPELATE CLASS V COMPLÈT CLASS V
 BRAZO ARM BRAS	300 CONVEXO CONVEX CONVEX	 CRISTAL GLASS GLACE	 ELÉCTRICO ELECTRIC ELECTRIQUE	 MANUAL MANUAL MANUEL	 TÉRMICO HEATED CHAUFFANT	IV Class CLASE CLASS CLASS



Who are we? / ¿Quiénes somos?

1966

Experience & Knowledge
Experiencia & Conocimiento



Innovation R+D+i & Competitiveness
Innovación I+D+i & Competitividad



Technology
Tecnología



Quality & Sustained Service Level
Calidad & Nivel Servicio Sostenible



Broad Products Range
Amplia Gama Productos



Export Oriented Company
Estrategia & Vocación Exportadora



Continuous Reinvestment
Reinversión Continua



Trust & Professionality
Confianza y Profesionalidad



Our Mission / Nuestra Misión



INNOVATION
INNOVACIÓN



QUALITY & DURABILITY
CALIDAD Y DURABILIDAD



END USER ORIENTATION
USUARIO FINAL





INDEX / INHALTSVERZEICHNIS / ÍNDICE

PILLARS AND ACCESSORIES

Mittlerungen und Zubehör / *Pilares y Accesorios*

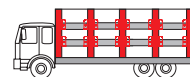

ROOF ELEVATION SYSTEMS

Hubdachsysteme / *Sistemas de Elevación de Techo*

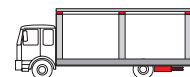

ADA-SLIDER SYSTEM

ADA-SLIDER System / *Sistema ADA-SLIDER*



MUDGUARDS AND WEDGES

Kotflügel und Radkeile / *Guardabarros y Calzos*

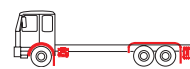

BOXES AND TANKS

Werkzeugkästen und Wassertanks/ *Cajones y Bidones*



PLYWOOD BOARDS AND CHASSIS ACCESSORIES

Schichtholzplatten-Fahrgestellzubehör / *Tableros y Accesorios de Chasis*



TEMPERATURE CONTROLLED TRANSPORT

Kühlfahrzeuge / *Transporte Frigorífico*

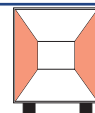

CURTAIN ACCESSORIES

Planenzubehör / *Accesorios de Lona*



LOCKERS

Verschlüsse / *Cierres*

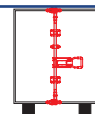

HINGES

Scharniere / *Bisagras*



PROFILES

Profilen / *Perfiles*

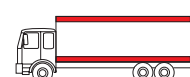

INDUSTRIAL SUPPLIES

Industriebedarf / *Suministros Industriales*



LOADING FASTENING SYSTEMS

Ladungssicherung / *Sistemas de Sujeción de Carga*

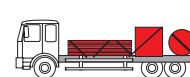

LIGHTING AND WARNING

Beleuchtung und Markierung / *Iluminación y Señalización*



REAR DOOR AND ACCESSORIES

Hecktüren und Zubehör / *Puertas Traseras y Accesorios*

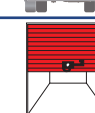

SAFETY AND ANTI-THEFT SYSTEMS

Sicherheit und Diebstahlsicherung / *Seguridad y Antirrobo*



CABIN ACCESSORIES

Kabinenzubehör / *Accesorios de Cabina*



INDEX / INHALTSVERZEICHNIS / ÍNDICE



pág.
7-36



pág.
37-46



pág.
47-54



pág.
55-84



pág.
85-138



pág.
139-184



pág.
185-196

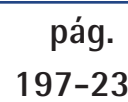

pág.
197-230



pág.
231-252



pág.
253-266

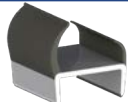

pág.
267-276



pág.
277-318



pág.
319-350



pág.
351-394



pág.
395-406



pág.
407-422



pág.
423-462



The whole specifications and characteristics on our photographs, drawings and charts are not contractual. ADAICO keeps the right to modify without prior notice any modification on our products in order to contribute to their improvement.

Carmaker Brands & Logos as well as OE Reference Numbers are only used with the purpose of specifying the vehicle the piece is applicable to. All such Carmaker Brands & Logos and OE Reference Number displayed in our documents are an exclusive propriety of their respective lawful owners.

Sämtliche Spezifikationen und Eigenschaften auf unseren Fotos, Zeichnungen und Grafiken sind nicht verbindlich. ADAICO behält sich das Recht vor, Änderungen an deren Produkten ohne vorherige Ankündigung vorzunehmen, um somit zu deren Verbesserung beizutragen.

Gleichwertige Qualitätsprodukte gemäß der Verordnung (EU) Nr. 461/2010. Die Verwendung von Herstellermarken und Originalreferenzen dienen ausschließlich zur Identifizierung der Teile, die in den Fahrzeugen verbaut werden. Alle Marken, die als Referenzen für die Anwendung der Ersatzteile, die in diesem Dokument erscheinen, sind Eigentum des Herstellers.

El conjunto de características y especificaciones de cada artículo aportadas en las fotografías, planos y tablas no son contractuales. ADAICO se reserva el derecho de realizar sin preaviso las modificaciones necesarias para contribuir a su mejora.

El uso de las marcas de fabricantes y de las referencias originales se hace exclusivamente con el propósito de indicar el modelo al que va destinada cada pieza. Todas las marcas que aparecen como referencias de aplicación de las piezas de recambio de este catálogo son propiedad de sus respectivos titulares registrales.

GENERAL CATALOGUE - 1st EDITION - 2024.

© **Copyright – ADAICO TRUCK & TRAILER S.L. - 2024.** All rights reserved. The content of this catalogue (photographs, patterns, drawings, texts, etc...) is the exclusive property of ADAICO TRUCK & TRAILER S.L., and it may not be partial or totally reproduced by any means, neither be added to any reusable data file system, nor be saved or transmitted by any means, computer, electronic, mechanical and/or photocopy without prior written permission by ADAICO TRUCK & TRAILER S.L. The infringement of previous rights will incur legal proceedings.

Digital Registration Certificate Nr: 2405308133241

Pilares y Accesorios
Pillars and Accessories
Ranchers et Accessoires
Rungen und Zubehör
Colunas e Acessórios

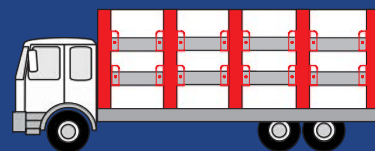

Pilares ADAICO

ADAICO Pillars

Ranchers ADAICO

ADAICO Rungen

Colunas ADAICO



pag. 8-27

Componentes Pilar

Pillar Components

Composants Rancher

Rungenbauteile

Componentes Pilar



pag. 28-36



ADAPTILLAR

for Curtain Sider
para Remolques Lona

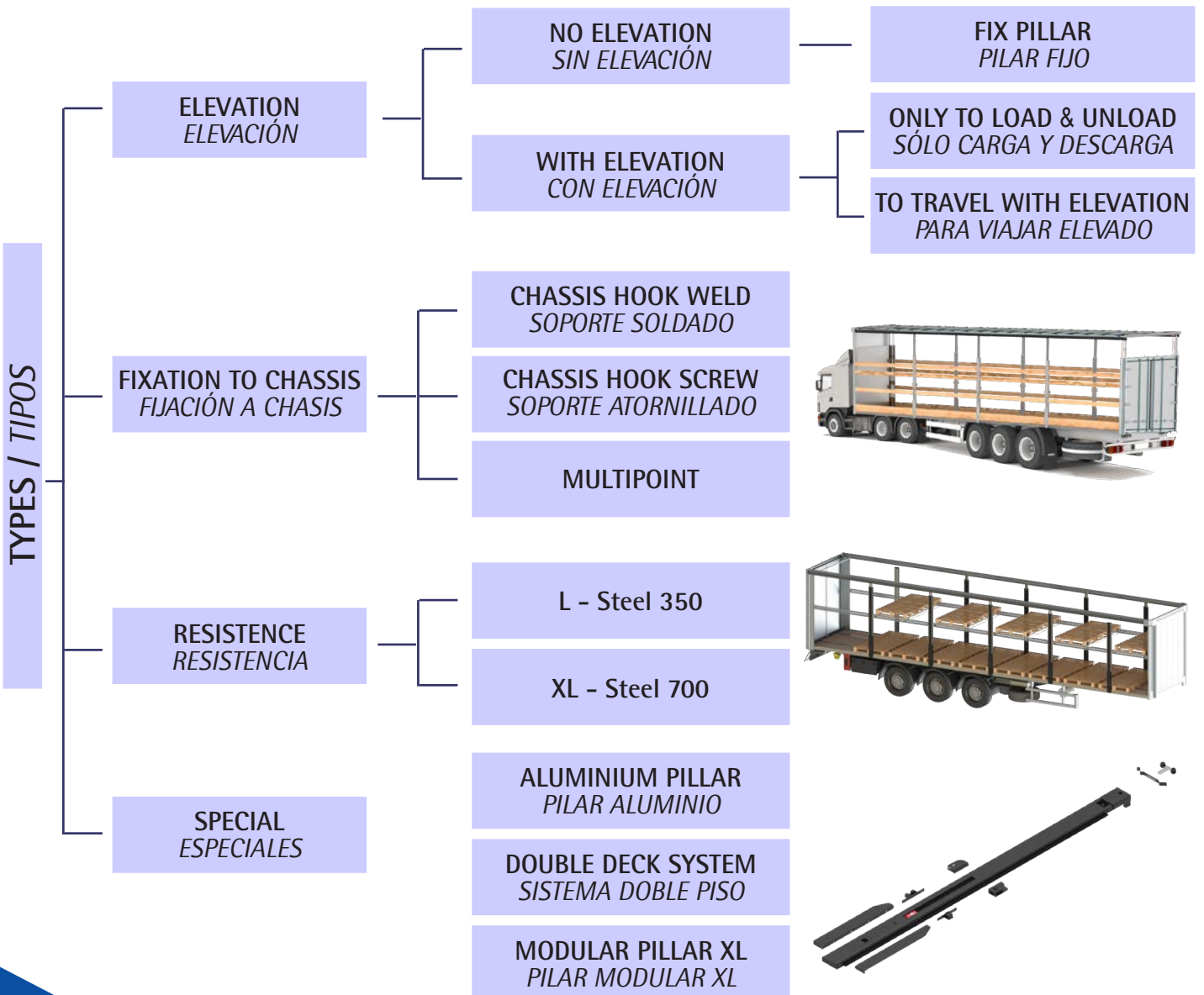



ERGONOMIC Handle
Manilla ERGONÓMICA

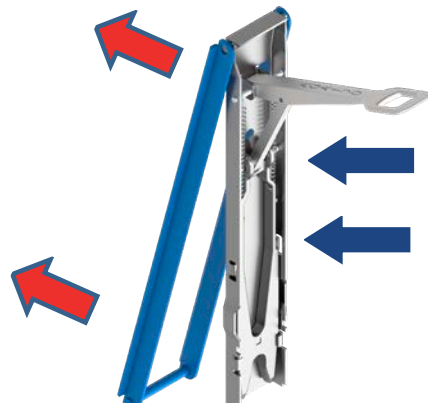

EASY Opening & Closing
FÁCIL APERTURA Y CIERRE



ANTI-BLOCKADING System
Sistema ANTI-BLOQUEO



PERFORATED Side for Riveting
Laterales PERFORADOS Remachables

Different SOLUTIONS for CHASSIS FIXATION
Distintas SOLUCIONES de FIJACIÓN al CHASIS





PILAR MODULAR XL

RANCHER MODULAIRE XL

Our new MODULAR SLIDING PILLAR is the SOLUTION for customers who:

- Do not want to order big amounts per each set type.
- Cannot stock dozens of different sets permanently.
- Need flexibility and immediate service.

Nuestro nuevo PILAR MODULAR es la SOLUCIÓN para clientes que:

- No quieren pedir grandes cantidades por cada tipo de conjunto.
- No pueden almacenar grandes cantidades de sets diferentes de forma permanente.
- Necesitan flexibilidad y servicio inmediato.



FLEXIBILITY
FLEXIBILIDAD

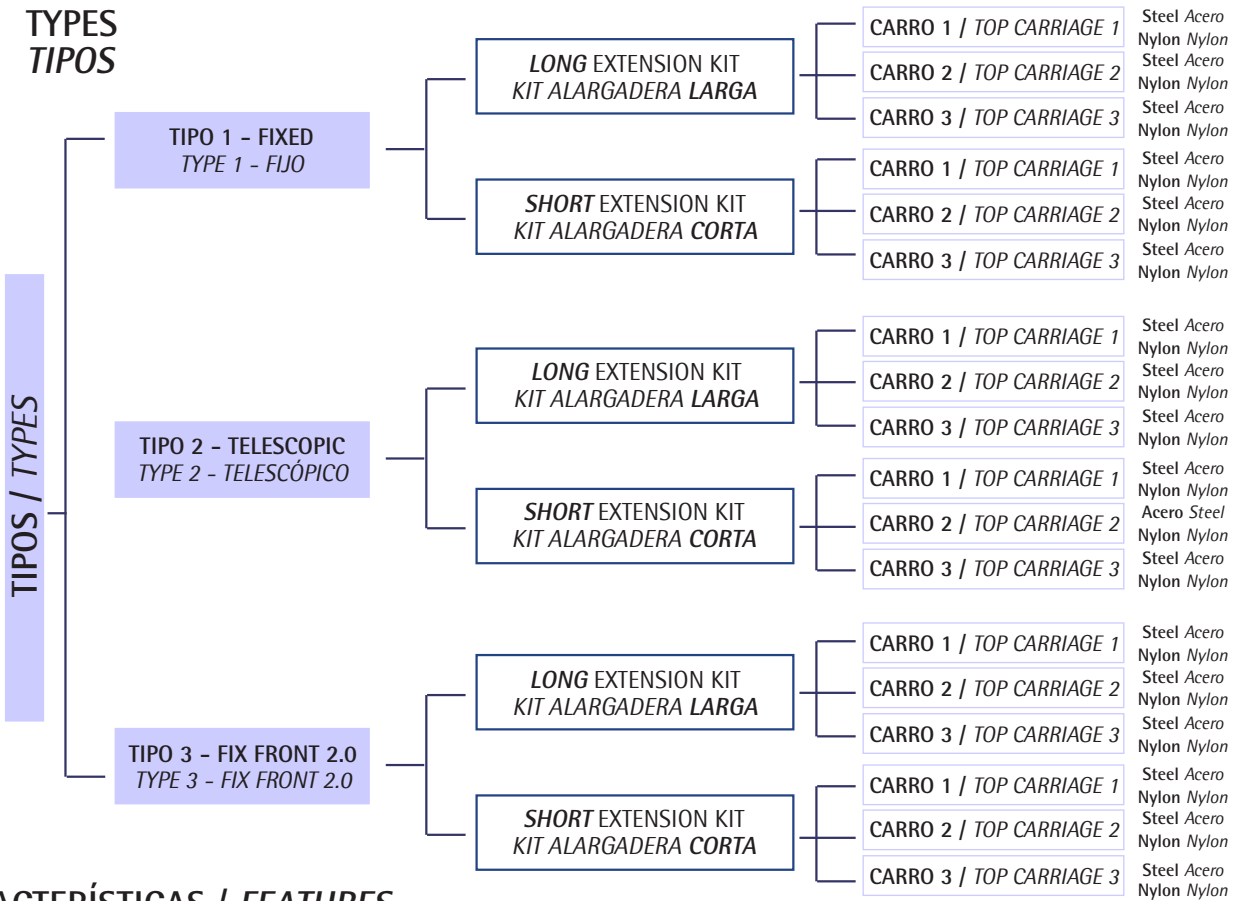

CARACTERÍSTICAS / FEATURES

Fixed
Fijo



with Elevation
con Elevación

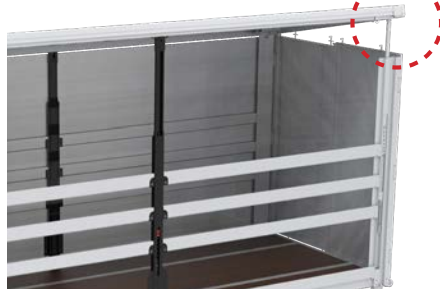

	Fixed	Telescopic	Fix Front 2.0
XL	✔ YES	✔ YES	✔ YES
Adjustable <i>Ajustable</i>	✔ YES	✔ YES	✔ YES
Elevable <i>Elevable</i>	✘ NO	✔ YES	✔ YES
Drive Roof Elevated <i>Viaja con techo elevado</i>	✘ NO	✘ NO	✔ YES

MODULAR PILLAR / MODULAR RUNGE / PILAR MODULAR

One BODY + different PARTS*
(that can be combined to fit to most trailers and truck bodies)

- ✓ Adaptable to most commercial roofs in the market.
- ✓ Covers a height range from 2.400 mm to 3.300 mm.
- ✓ Optional: with or without elevation.
- ✓ Suitable for XL certified bodies.

Un Pilar + diferentes COMPONENTES*
(que se pueden combinar para adaptarse a la mayoría de los remolques y carrocerías de camiones)

- ✓ Adaptable a la mayoría de techos comerciales del mercado.
- ✓ Cubre un rango de altura desde 2.400 mm. hasta 3.300 mm.
- ✓ Opcional: con o sin elevación.
- ✓ Apto para carrocerías con certificación XL.

ADAPTABLE TO ANY BODY
ADAPTABLE A CUALQUIER CARROCERÍA



*These body and parts are standard and permanently available in our stock

*Tanto el pilar como los componentes son estándar y se encuentran disponibles permanentemente en nuestro stock.

SET1 - FIXED

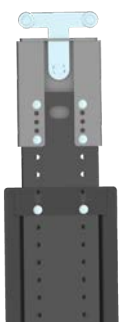

rear view
visión trasera

SET2 - TELESCOPIC

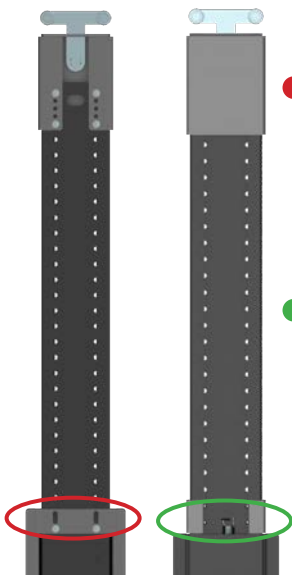

rear view
visión trasera front view
visión frontal

- **Telescopic Extension**
Alargadera Telescópica
It can be rivetted at the desired height.
Puede ser remachada a la altura deseada.
- We will also rivet 2 metallic accessories that will act as stoppers
También puede remacharse dos accesorios metálicos que la bloquean.

SET3 - FIX FRONT 2.0



Easy Fixing 2.0



visión frontal
front view



visión trasera
rear view



XL Modular Pillar
XL Modular Runge
Pilar Modular XL

NEW

XL MODULAR PILLAR PILAR MODULAR XL

Ref	Kg	Mat	Sup/Finish Acabado	Thickn. Espesor	Lot
0508010	20.4	STEEL	KTL	3 mm.	1

CS trucks fixed or with elevation (optional fixfront) | Special Mechanism |
Pillar Body: Steel type S700 MC 3mm | Treatment: KTL 10 µm
Para Curtain-Sider techo con y sin elevación (opción fix-front) | Mecanismo Especial |
Omega: Acero S700MC e=3mm | Tratamiento: KTL 10 µm

SET1 FIXED	✓	✓	✓	✓	✗	✗	✓	✓	✓
SET2 TELESCOPIC	✓	✓	✓	✓	✓	✗	✓	✓	✓
SET3 FIX-FRONT 2.0	✓	✓	✓	✓	✓	✓	✓	✓	✓
Internal Height Altura Interna	Pillar Body Pilar	Extension Kit Kit Alargadera	Top Carriage Carro	Roller Ruleta	Elevation Kit Kit Elevación	Locking Pin Pin Bloqueo	Blocking Strip Tira Bloqueo	Chassis Hook Soporte Chasis	Options Opciones
SHORT CORTO 2.400 - 2.950 mm.	0508010	0508020	0508030	0801140	0508600	0508500	0508090	0508060	0502212/13
		0508022	0508032	0801139	0502544/45				
LONG LARGO 2.750 - 3.300 mm.			0508034						1204009
									0508070

HEIGHT RANGES RANGO DE ALTURAS

SHORT - Internal Height
CORTO - Altura Interna
2.400-2.950 mm.

LONG - Internal Height
LARGO - Altura Interna
2.750-3.300 mm.

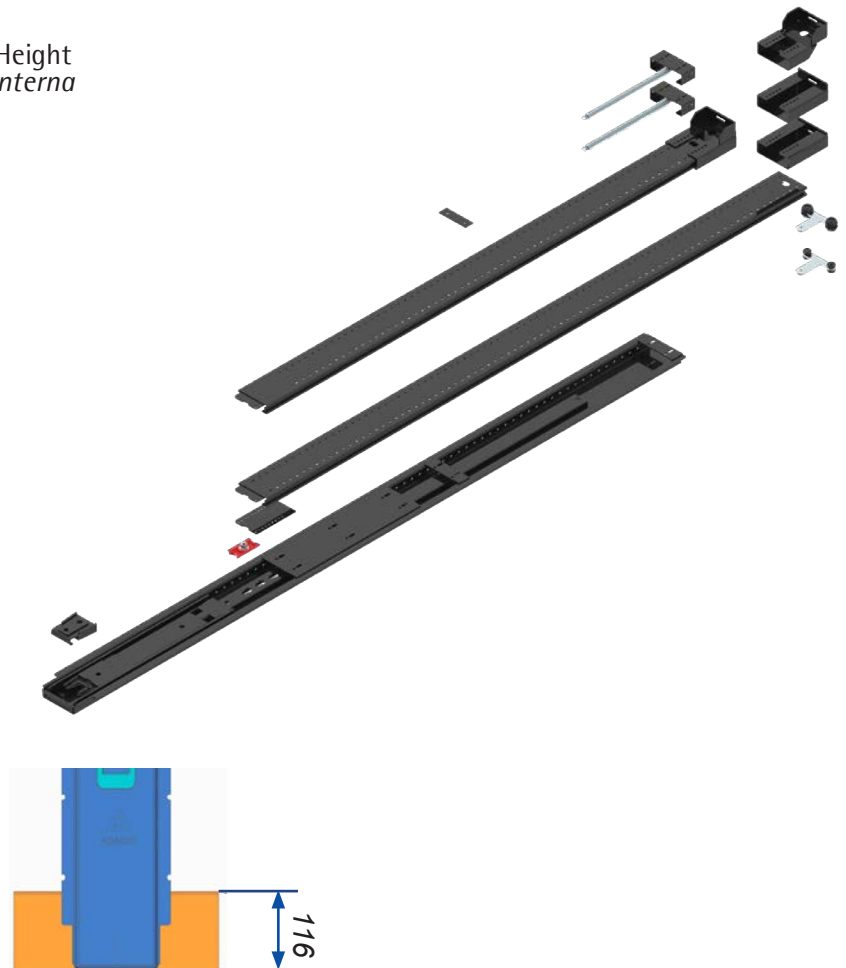
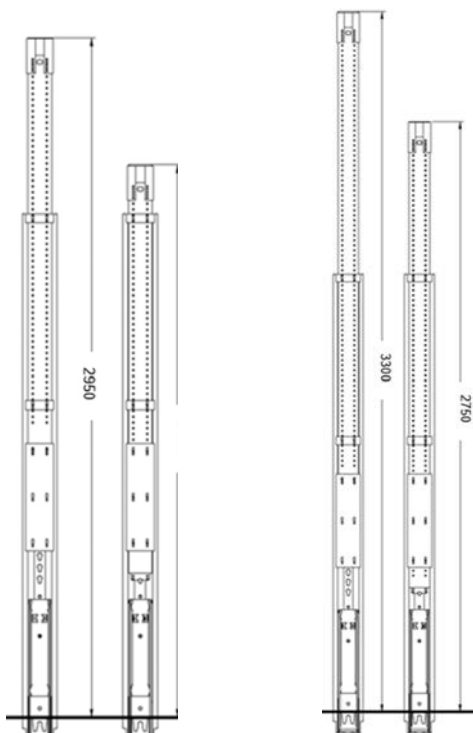



List of Modular Pillar-Rollers-Roofs
 Modular Rungen-Rollen-Dach Aufstellung
 Tabla de aplicaciones Pilar Modular-Carros-Techos

Ref. Art-Nr.	Versus	Autocar	Edscha	Sesam
0508030	VS nano; VS alto 150; VS Feralo; VS EURO	A small; A slim light	E-volumen; Hubdach/ Lift CS-Lite plus 175; Vp profi alu	S slimliner large
0508032	Vs duo; mycro		E standar; E standar CS 125; E standar CSLite plus 125; E Maut/Toll CS-Liteplus 110	S Slimliner small; S Slimliner medium
0508034	VS quadro; VS plano; Vs Kubus;	A std	E standar CS 115	S multiliner combi 2004; S Flatiner; S Multiliner mix 2004

ADAPTABLE TO ANY BODY
 ADAPTABLE A CUALQUIER CARROCERÍA

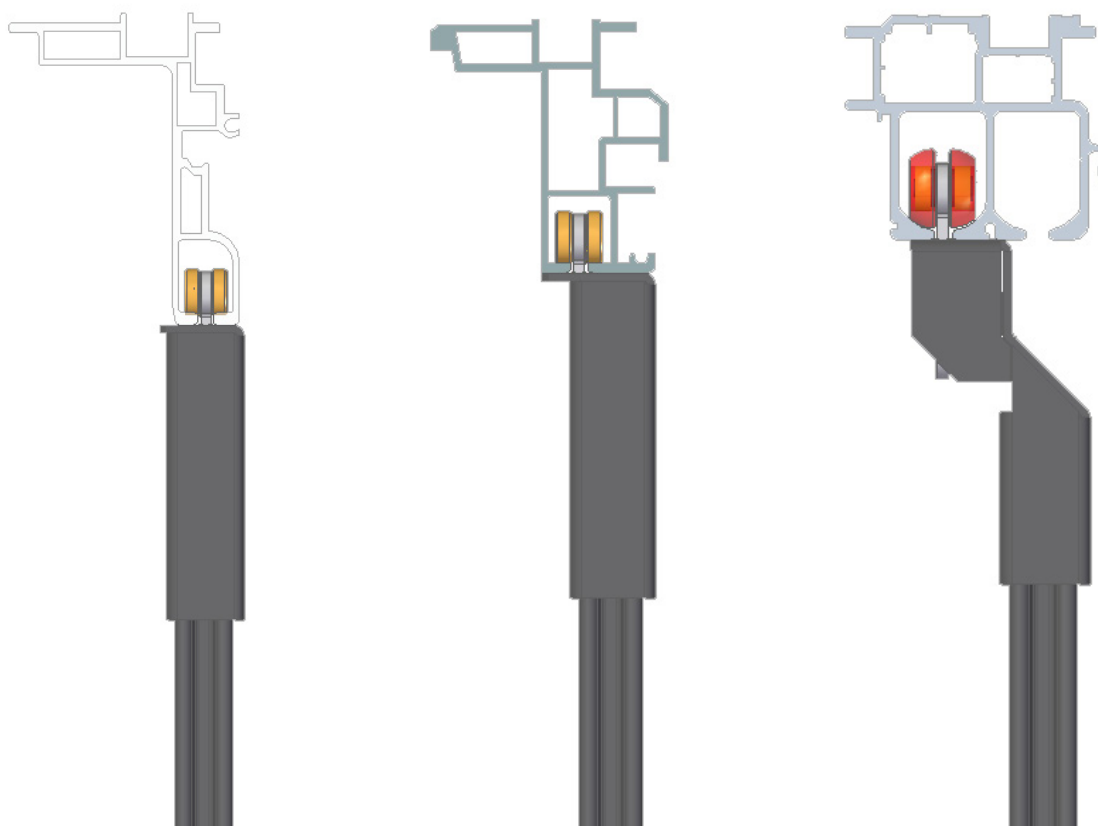



L Fix Pillar
L Fix Runge
Pilar Fijo L

Ref	Kg	Mat	Sup/Finish Acabado	Col	Thickn. Espesor	Lot
0505010	23.5	STEEL			3 mm.	1
0505014	23.6	STEEL	KTL		3 mm.	1

CS trucks no roof elevation cut to desired height|Mechanism Standard|
Pillar Body: Steel type S355MC 3mm|Treatment: KTL 10 µm (option stripped steel)
Para Curtain-Sider techo sin elevación (cortar a altura)|Mecanismo Estándar|
Omega:Acero S355MC e=3mm|Tratamiento: KTL 10 µm (opcional chapa decapada)

L FIX PILLAR PILAR FIJO L

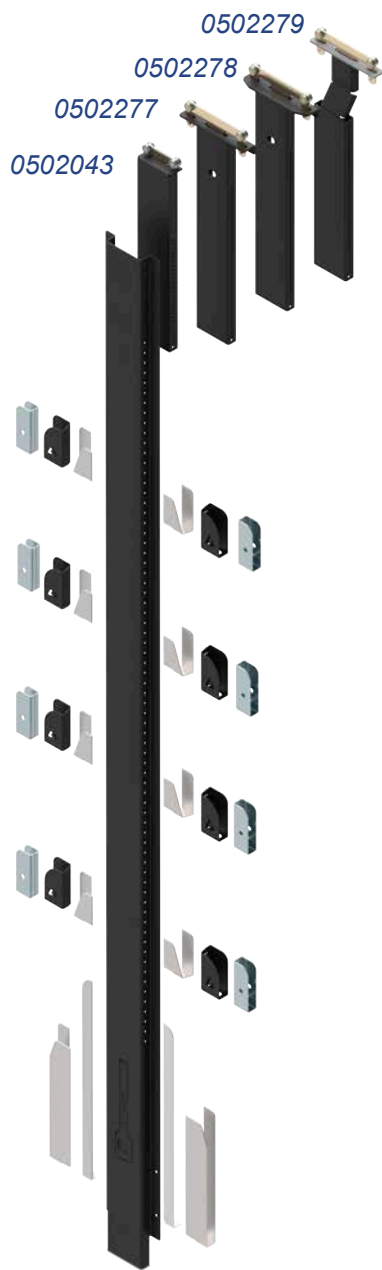

TOP ROLLERS CARROS

TIMBERHOLDERS CARTOLILLAS

to rivet
para remachar



0502212/13

to weld
para soldar

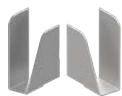

0502542/43

to weld
para soldar



0502209

to weld
para soldar



0502540/41

to weld
para soldar



0502206/18

POCKET UÑA



1204056

CHASSISHOOK SOPORTES

Standard
Estándar



0502080

MECHANISM MECANISMO

Standard
Estándar



0502002/0506002

to weld
para soldar

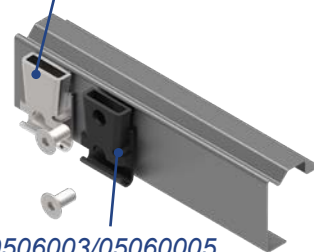

0506003/0506005

to rivet
para remachar

XL Fix Pillar
XL Fix Runge
Pilar Fijo XL

XL FIX PILLAR PILAR FIJO XL

Ref	Kg	Mat	Sup/Finish Acabado	Col	Thickn. Espesor	Lot
0505130	18.2	STEEL	KTL	●	2,5 mm.	1

CS without roof elevation. h>2520
Para Curtain-Sider techo sin elevación y h>2520

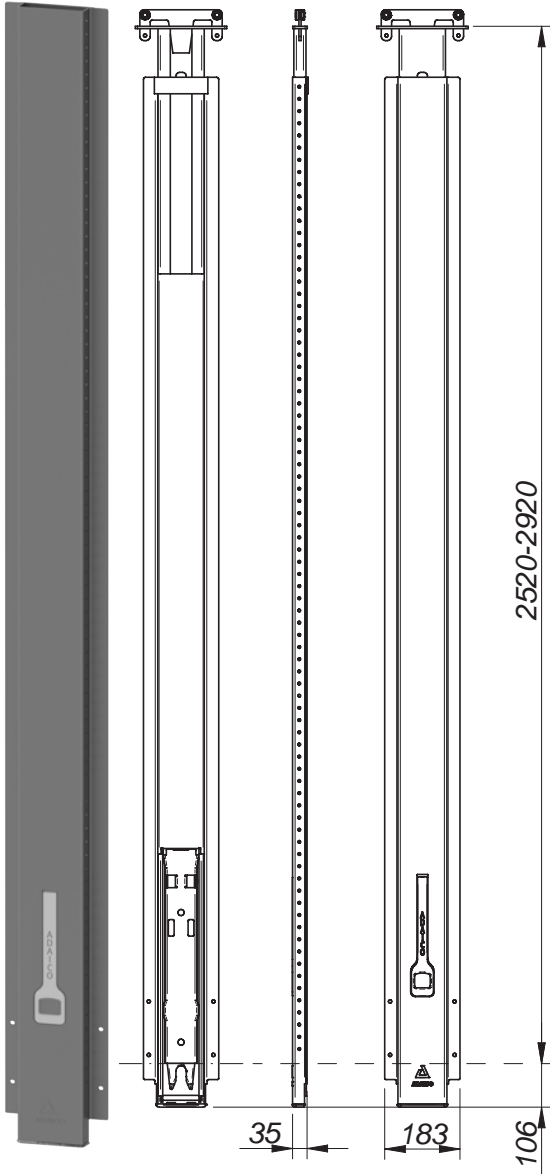

MECHANISM MECANISMO

Reduced
Reducido



0502090

TIMBERHOLDERS CARTOLILLAS

to rivet
para remachar



0502212/13

to rivet
para remachar



0502214/15

CHASSISHOOK SOPORTES

Reduced
Reducido



0506026
to weld
para soldar

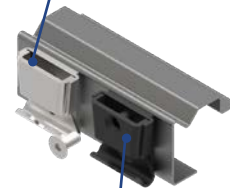

0506024
to rivet
para remachar



ADAICO

PILLARS AND ACCESSORIES / RUNGEN UND ZUBEHÖR / PILARES Y ACCESORIOS



XL Telescopic Pillar
XL Teleskopische Runge
Pilar Telescópico XL

ONLY TO LOAD & UNLOAD (XL) SOLO CARGA Y DESCARGA (XL)

Ref	Kg	Mat	Sup/Finish Acabado	Col	Thickn. Espesor	Lot
0505518	21	STEEL	KTL	●	2,5 mm.	1

CS trucks roof elev. h>2520 >2920 mm. carros 0502261/2/3. (carga-descarga, no viajar elevado) |
 Mecanismo Reducido|Omega: S/700MC e=2,5 mm. | KTL 30 µm
 Curtain-sider techo c/elev. h>2520 >2920 mm. carros 0502261/2/3. (carga-descarga, no viajar elevado) |
 Mecanismo Reducido|Omega: S/700MC e=2,5 mm. | KTL 30 µm

TOP ROLLERS CARROS

0502263

0502262

0502261

TIMBERHOLDERS CARTOLILLAS

to rivet
para remachar



to rivet
para remachar

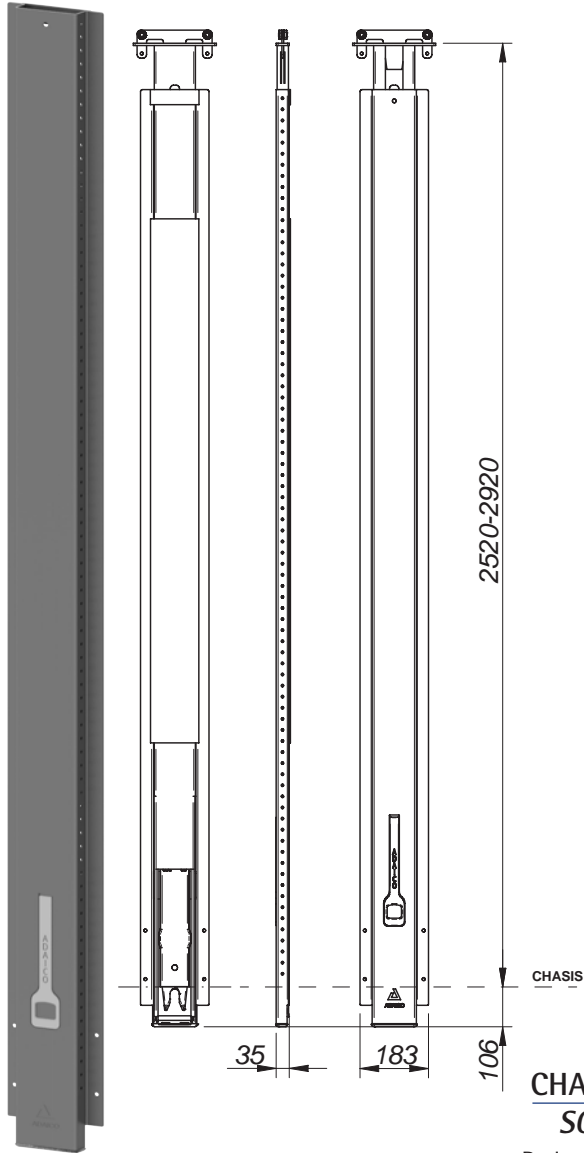

CHASSISHOOK SOPORTES

Reduced
Reducido

MECHANISM MECANISMO

Reduced
Reducido



0506026
to weld
para soldar

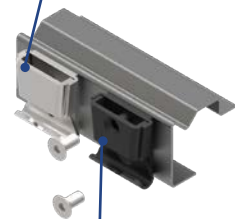

0506024
to rivet
para remachar



L Fix-front Pillar
L Fix-Front Runge
Pilar Fix-front L

TO TRAVEL WITH ELEVATION (L)
PARA VIAJAR ELEVADO (L)

PILLARS AND ACCESSORIES / RUNGEN UND ZUBEHÖR / PILARES Y ACCESORIOS

Ref	Kg	Mat	Sup/Finish Acabado	Col	Thickn. Espesor	Lot
0505109	18	STEEL	KTL	●	3 mm.	1

CS trucks with roof elevation | h>2520 >2920mm. top part 0502286 | Mechanism: Reduced |
Pillar-Body: Steel type S355MC 3mm. | Treatment: KTL 30 µm
Para Curtain-Sider de techo con elevación y h>2520 >2920 mm. para 0502286 |
Mecanismo Reducido | Omega: S355MC 3mm. | KTL 30 µm

TOP ROLLERS
CARROS



TIMBERHOLDERS
CARTOLILLAS

to rivet
para remachar



0502212/13

to rivet
para remachar



0502214/15

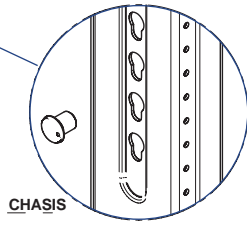
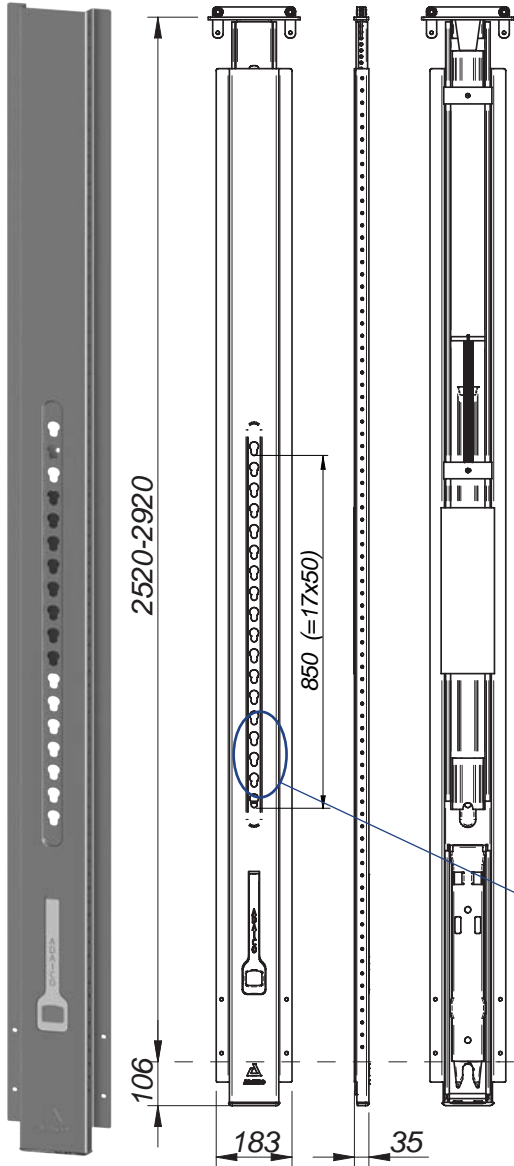

CHASSISHOOK
SOPORTE

Reduced
Reducido

MECHANISM
MECANISMO

Reduced
Reducido



0502090

0506026
to weld
para soldar

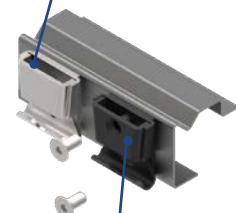

0506024
to rivet
para remachar



XL Fix-front Pillar
XL Fix-Front Runge
Pilar Fix-front XL

Ref	Kg	Mat	Sup/Finish Acabado	Col	Thickn. Espesor	Lot
0505550	18.3	STEEL	KTL	●	2,5 mm.	1

CS with roof elevation. h>2520
Para Curtain-Sider techo con elevación h>2520

TO TRAVEL WITH ELEVATION (XL) PARA VIAJAR ELEVADO (XL)

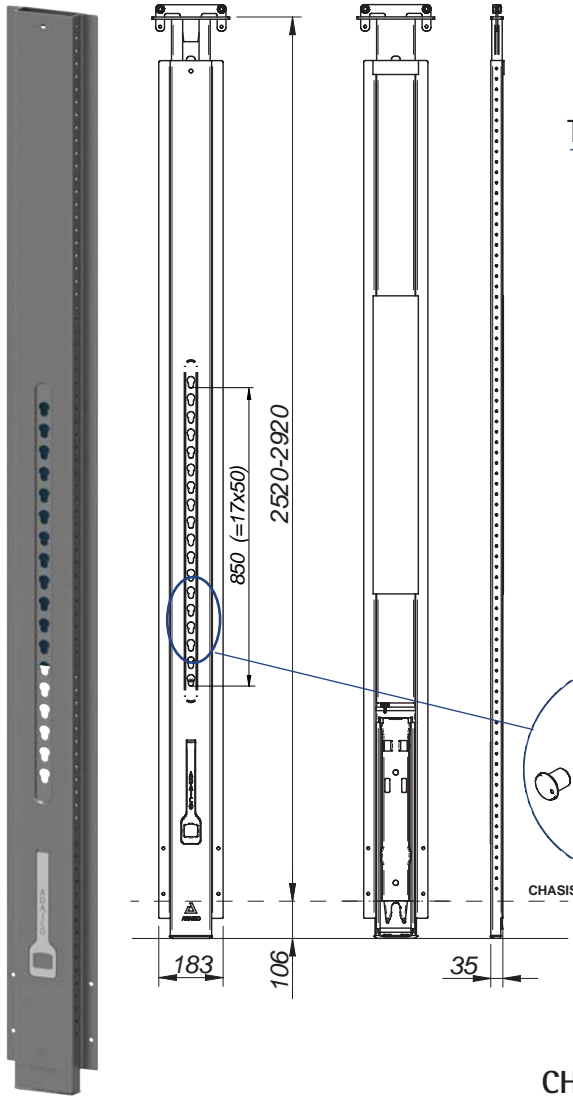

TIMBERHOLDERS CARTOLILLAS

to rivet
para remachar



to rivet
para remachar



TOP ROLLERS CARROS



CHASSISHOOK SOPORTES

Reduced
Reducido

MECHANISM MECANISMO

Reduced
Reducido



0506026
to weld
para soldar

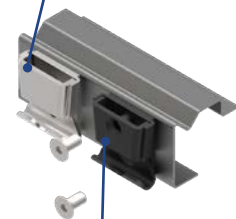

0506024
to rivet
para remachar



Multipoint Pillar
 Multipoint-Runge
 Pilar Multipoint

MULTIPOINT MULTIPOINT

Ref	Kg	Mat	Sup/Finish Acabado	Col	Thickn. Espesor	Lot
0506305	24.75	STEEL	KTL	●	3 mm.	1

CS trucks no roof elevation cut to desired height | Mechanism Standard |
 Pillar Body: Steel type S355MC 3mm | Treatment: KTL 10 µm (option stripped steel)
 Para Curtain-Sider techo sin elevación (cortar a altura) | Mecanismo Estándar |
 Omega: Acero S355MC e=3mm | Tratamiento: KTL 10 µm (opcional chapa decapada)

TOP ROLLERS CARROS

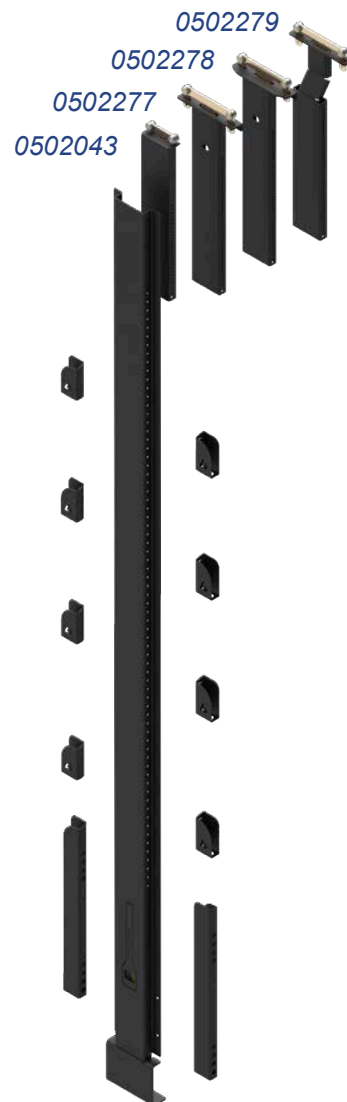

TIMBERHOLDERS CARTOLILLAS

to rivet
 para remachar



0502212/13

to rivet
 para remachar



0502214/15

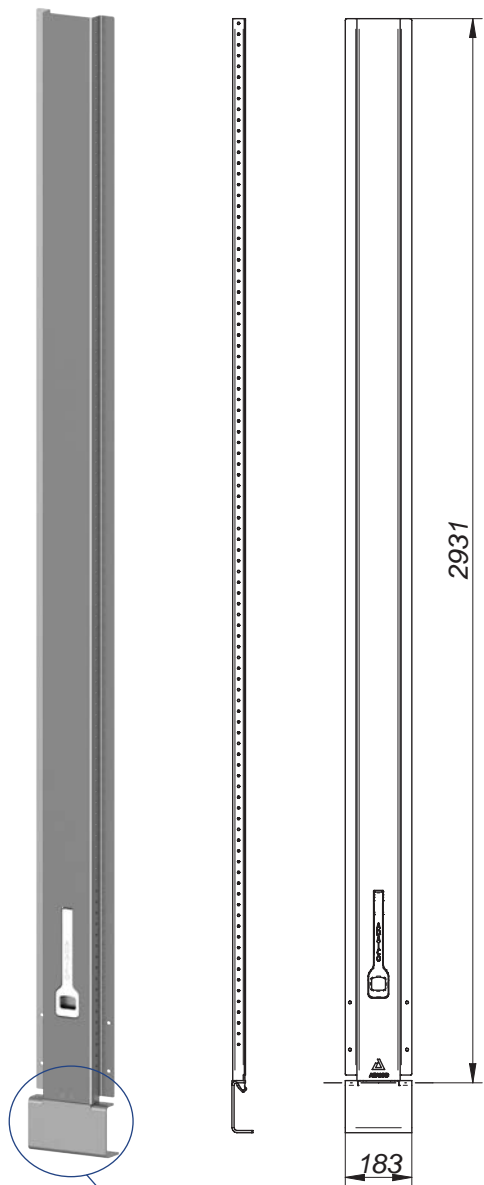

CHASSISHOOK SOPORTES

Adjustable to Chassis
 Ajustable a Chasis



PILLARS AND ACCESSORIES / RUNGEN UND ZUBEHÖR / PILARES Y ACCESORIOS



Aluminum Pillar
Aluminium Runge
Pilar de Aluminio

Ref	Kg	Mat	Lot
0505096	13.7		1

Light Alu Pillar for CS without roof elevation | Mechanism: Riveted with cataphoretic painting |
Pillar-Body: Alu type 6082 T-6.
Pilar ultraligero Para Curtain-Sider de techo sin elevación | Mecanismo Remachable con KTL |
Omega: Aluminio aleación 6082 T-6.

ALUMINIUM PILLAR PILAR ALUMINIO

TIMBERHOLDERS CARTOLILLAS

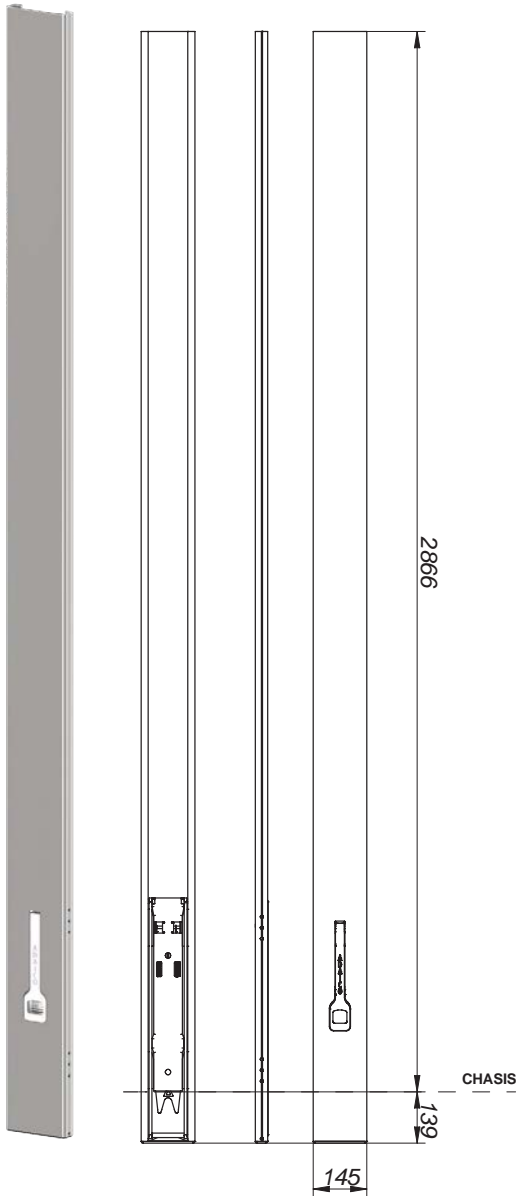

to rivet
para remachar



0502212/13

to rivet
para remachar



0502214/15

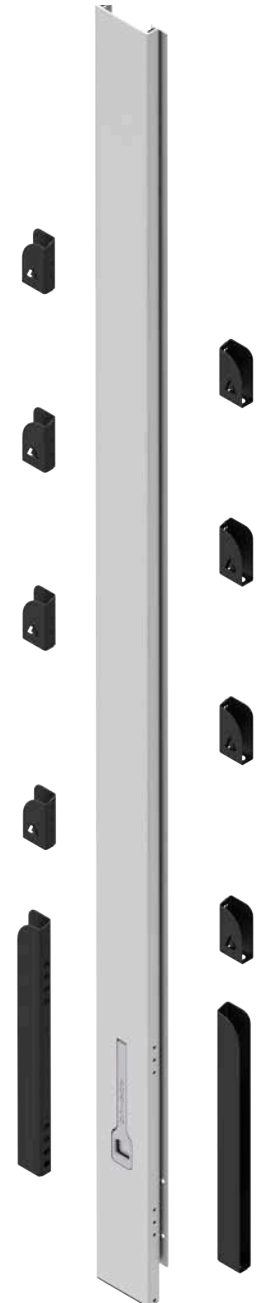

CHASSISHOOK SOPORTES

Standard
Estándar



0502002/0506002
to weld
para soldar

0506003/0506005
to rivet
para remachar



XL Double Deck Pillar
 XL Doppelstock-Runge
 Pilar Doble Piso XL

DOUBLE DECK DOBLE PISO

Ref	Kg	Mat	Sup/Finish Acabado	Col	Thickn. Espesor	Article	Lot
0505802	25.4	STEEL	KTL	●	2,5 mm.	with Elevation c/Elevación	1
0505804	25.4	STEEL	KTL	●	2,5 mm.	Fixed Fijo	1

CS trucks fixed and with elevation | h > 2576 > 2976 mm. carros 0502287/8 | Mecanismo Reducido |
 Omega: S/700MC e=2,5mm. | KTL 30 µm
 Para Curtain-sider fijo o c/elevación h > 2576 > 2976 mm. carros 0502287/8 | Mecanismo Reducido |
 Omega: S/700MC e=2,5mm. | KTL 30 µm

TOP ROLLERS CARROS

0505802+0502288

0505804+0502287

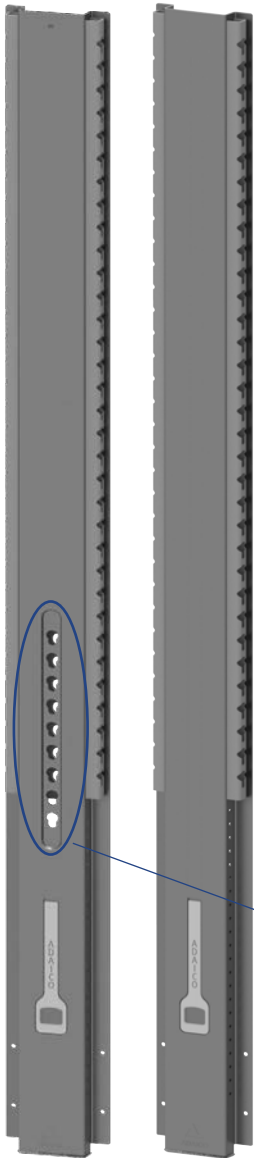

0505802 0505804

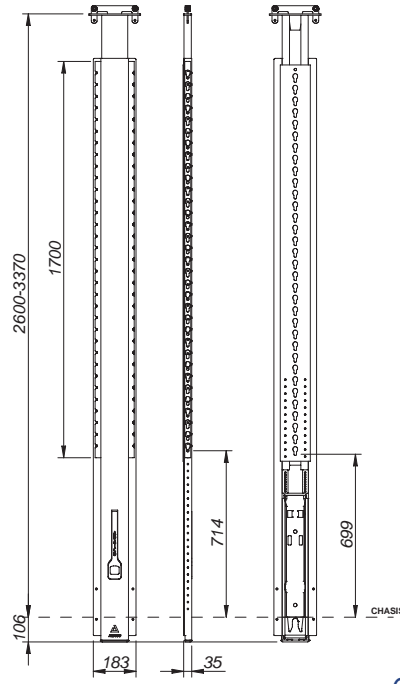
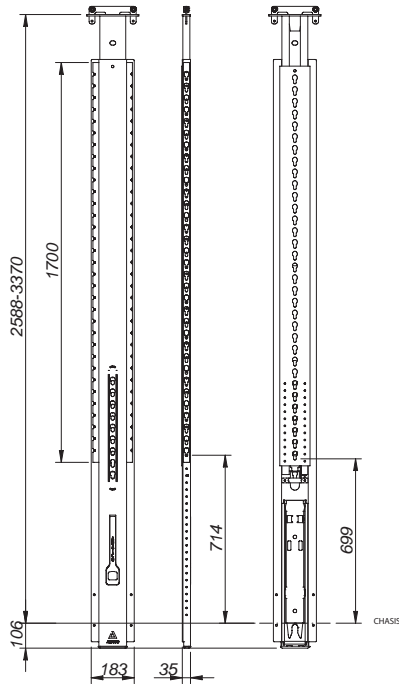

0502287

0502288



0505804

0505802

TIMBERHOLDERS CARTOLILLAS

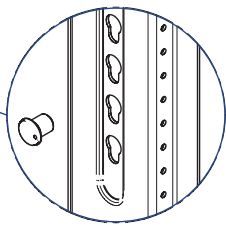

2301212



0502214/15

CHASSISHOOK SOPORTES

Reduced
 Reducido

MECHANISM MECANISMO

Reduced
 Reducido



0502090

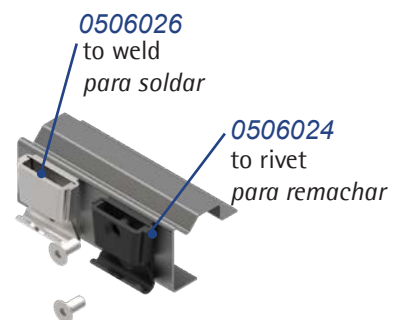

PILLARS AND ACCESSORIES / RUNGEN UND ZUBEHÖR / PILARES Y ACCESORIOS



Double Deck System / Dopplestock Deck Sys

PILLARS AND ACCESSORIES / RUNGEN UND ZUBEHÖR / PILARES Y ACCESORIOS



Ref. Art-Nr.	Description Beschreibung Descripción	Quantity Menge Cantidad		Standard Length Standardlänge Longitud Standard	Maximum load Maximale Belastung Carga Máxima
		Pillar / Runge / Pilar			
		0505802 (Elev.)	0505804		
2301130	Double Deck Profile 1,07 m. Doppelstock Profil 1,07 m. Perfil Lateral Doble Piso 1,07 m.	2		1.070 mm.	1.250 daN
2301131	Double Deck Profile 2,2 m Doppelstock Profil 2,2 m Perfil Lateral Doble Piso 2,2 m.	10		2.200 mm.	1.250 daN
2301212	Timberholder Balk Schoen Cartolilla	optional		-	-
2301129 2301138	U Profile 1,7 m. U Profil 1,7 m. U Perfil 1,7 m.	4		1.700 mm.	-
2301236	Loading Bar Klemmbalken Barra Carga	24		2.200-2.500 mm.	1.000 daN
0502288	Pillar Extension Kit (Elev.) Schiebling Kit (Elev.) Kit Alargadera-Carro (Elev.)	10		-	-
0502287	Pillar Extension Kit Schiebling Kit Kit Alargadera-Carro		10	-	-

System / Sistema Doble Piso

PILLARS AND ACCESSORIES / RUNGEN UND ZUBEHÖR / PILARES Y ACCESORIOS

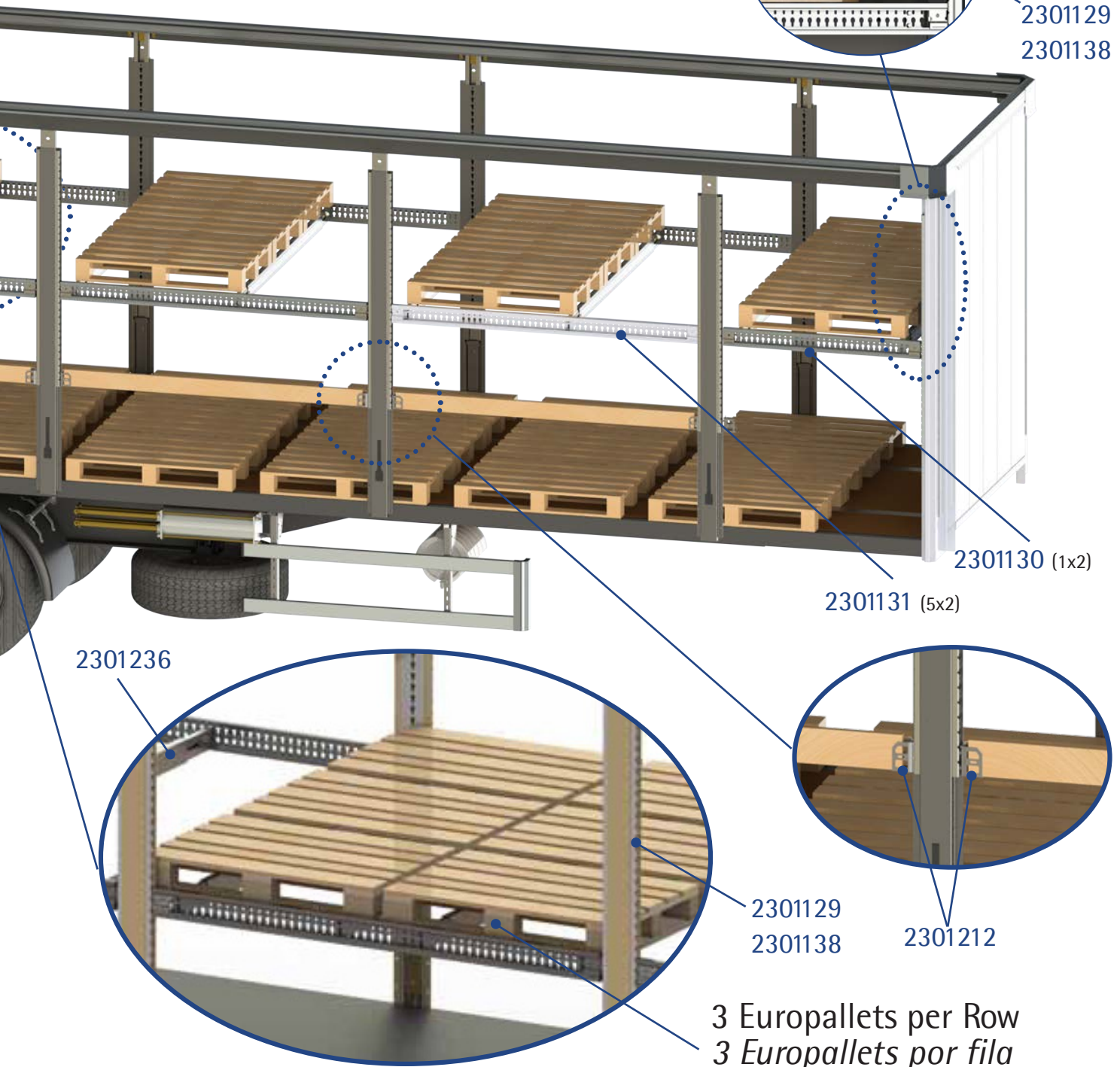

- Quantities for a standard 13,62 meters trailer.
- Positioning of 33 spaces for euro pallet on the second level.
- Maximum weight of euro pallet for side bar on standard length: 500 Kg.
- Warning: The maximum total weight allowed on the second level must be specified by the manufacturer of the trailer.

- Systemkomponenten für 13,62 m. Standardsattelanhänger.
- Schaffung von 33 Euro -Paletten - Stellplätzen in der 2. Ebene.
- Max. Palettgewicht bei Längsbalken in Standardlänge: 500 Kg.
- Hinweis: Die max. Gesamtbelastbarkeit der 2. Ladeebene wird vom Hersteller des Sattelanhängers vorgegeben.

- Cantidades para un semirremolque estándar de 13,62 m.
- Colocación de 33 espacios de europalet en el segundo nivel.
- Peso máximo por palet por barra lateral en longitud estándar: 500 Kg.
- Advertencia: La carga total máxima admitida del segundo piso debe ser dada por el fabricante del semirremolque.



Questionnaire of Pillars / Cuestionario Pilares

1. ARE YOU GOING TO CERTIFY YOUR TRUCK-BODY LIKE L OR XL (EN-12642-XL)?
¿UD. VA A CERTIFICAR SU CARROCERIA COMO L O XL (EN-12642-XL)?

- L
- XL
- No Certificate
- Sin Certificado



2. FIXATION TO CHASSIS FIJACIÓN A CHASIS

- 2.1 Chassis hook type (Reference) _____
Tipo de soporte (Referencia)
- 2.2 To weld To screw
Para soldar Para atornillar
- 2.3 Chassis side profile height (mm.)
Altura del chasis (mm.)
 $H_1 =$ _____
- 2.4 No chassis hook (Multipoint, please see catalogue for more details)
Sin soporte de pilar (pilar Multipoint, ver más detalles en catálogo)

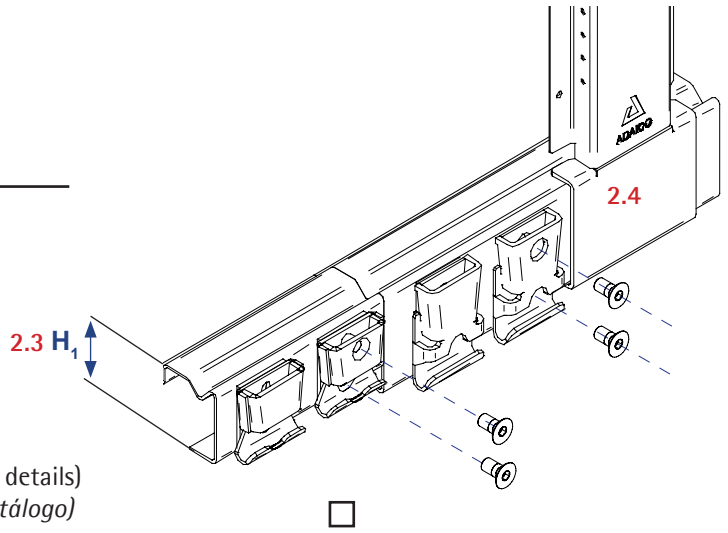

3. INDICATE YOUR ROOF PROFILE MODEL INDICAR MODELO DE TECHO

*(If different to Edscha, Sesam, Autocar or Versus models a drawing is required)
(En caso de no ser de Edscha, Versus Omega, Autocar o Sesam enviar plano)

- 3.1 Ancho techo / Dachbreite: L1= _____
- 3.2 Ancho chasis / Chassisbreite: L2= _____
- 3.3 Offset: L3= _____

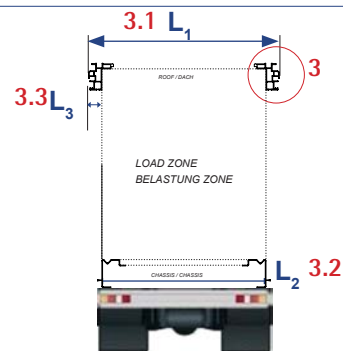

4. ROOF ELEVATION ELEVACIÓN DE TECHO:

- 4.1 Has the vehicle roof elevation? Please indicate elevation range in mm.
¿El vehículo tiene elevación de techo? (Por favor indique rango de alturas a cubrir)
Yes / Sí $H_2 =$ _____
No / No

4.2 Does the vehicle need to travel with elevated roof? Is a mechanical height fixing system needed in the pillar?
¿El vehículo necesita viajar con el techo elevado? ¿Necesita una fijación mecánica de la altura a diferentes niveles en el pilar?

- Yes / Sí
- No / No

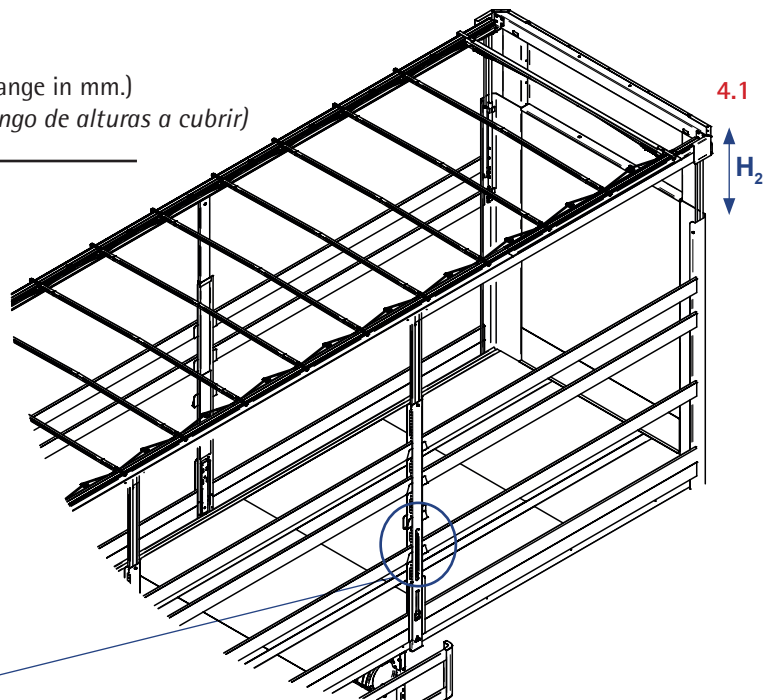
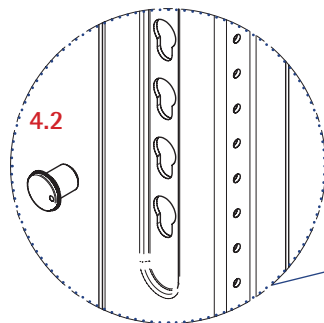

5. VEHICLE INTERNAL HEIGHT (FROM CHASSIS UPPER EDGE TO ROOF PROFILE DOWN EDGE)
ALTURA INTERNA DEL VEHÍCULO (DESDE EL BORDE SUPERIOR DEL CHASIS HASTA EL BORDE INFERIOR DEL PERFIL DE TECHO)

- 5.1 Range of heights (mm.):
Rango de alturas a cubrir (mm.): min: _____ max: _____
- 5.2 One height (mm.):
Una altura (mm.): $H_3 =$ _____

6. TIMBERHOLDERS
CARTOLILLAS

- 6.1 To weld *Para soldar* to rivet *para remachar* 5.1 / 5.2 H_3
- 6.2 Reference _____ and N° of **big** timberholders per pillar (0 or 2) 0
Referencia _____ *y N° de cartolillas grandes por pilar (0 o 2)* 2
- 6.3 Reference _____ and N° of **small** timberholders per pillar _____
Referencia _____ *y N° de cartolillas pequeñas por pilar* _____
- 6.4 In case of needing them mounted, please indicate A, B and C measurements:
En caso de querer que se le suministren montadas indicar separación A, B y C:
 (mm.) A B C

- 6.5 Please give thickness of wooden or aluminium sideboard:
Indicar espesor de tabla o cartola (mm.):

e = _____

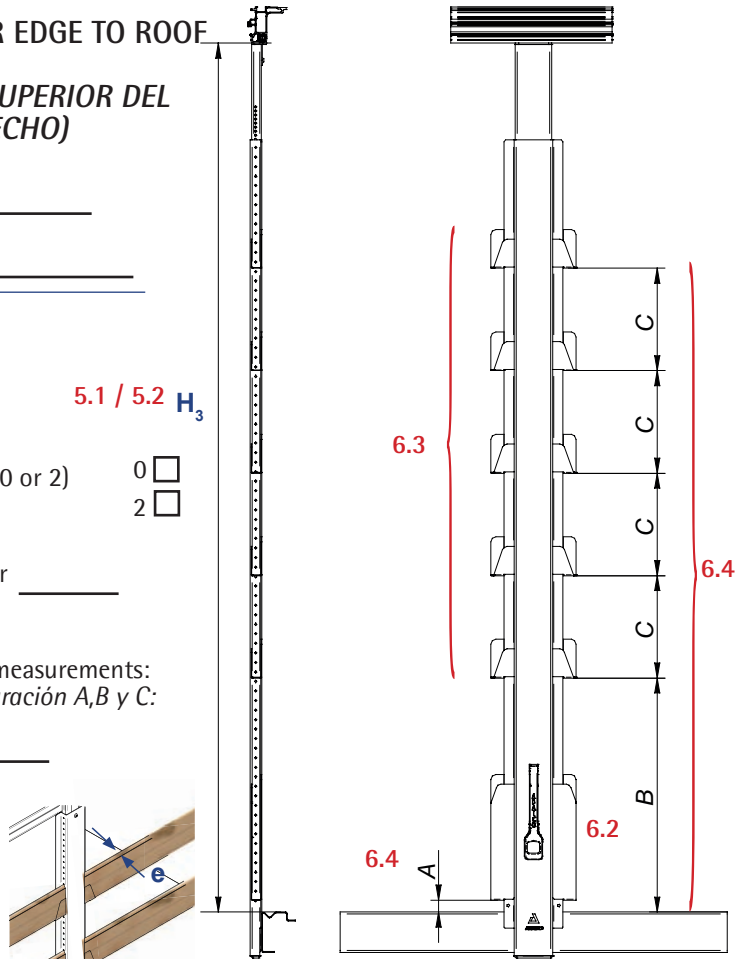

7. SIDE BOARD LOCKS
CIERRES DE CARTOLA

In case of needing indicate:
En caso de necesitarlos indicar:

- 7.1 Height of the pocket from chassis upper edge $H_4 =$ _____
Altura de la uña desde borde superior del chasis
- 7.2 Sideboard Lock Reference:
Referencia del cierre de cartola:
(ver catálogo/ siehe Katalog) _____

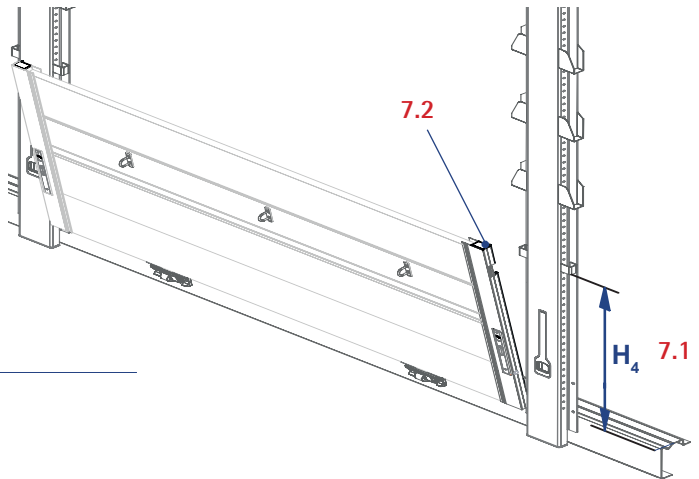

8. SURFACE TREATMENT
TRATAMIENTO SUPERFICIAL

- 8.1 KTL Cathaphoretic treatment (please indicate thickness in microns μ) _____
Cataforesis (indicar espesor en micras μ)
- 8.2 Acrylic painting (please indicate thickness in microns and color RAL code) _____
Pintura acrílica (indicar espesor en micras μ y color RAL)
- 8.3 Others (please describe) _____
Otros (Especificar)
- 8.4 Raw
Sin recubrimiento

OTHER COMMENTS / COMENTARIOS:



PILLARS AND ACCESSORIES / RUNGEN UND ZUBEHÖR / PILARES Y ACCESORIOS

Ref.	Image	0505010 0505014	0505130	0505518	0505109	0505550	0506305	0505096	0505802 0505804
		Standard L	Standard XL	Telescopic XL	Fix-Front L	Fix-Front XL	Multipoint	Alu	Double Deck XL
0502043		✓					✓		
0502277 0502278 0502279		✓					✓		
0502286					✓				
0505287 0505288									✓
0502293 0502294 0502295			✓						
0502270 0502271 0502275						✓			
0502261 0502262 0502263				✓					
0502002 0506002		✓						✓	
0506003 0506005		✓						✓	
0506024 0506026			✓	✓	✓	✓			✓
0502212 0502213		✓	✓	✓	✓	✓	✓	✓	
0502214 0502215			✓	✓	✓	✓		✓	
0502526 0502527			✓	✓	✓	✓			
0502206 0502218		✓					✓		
0502209		✓					✓		
0502540 0502541		✓					✓		
0502542 0502543		✓					✓		
Clamp Uña	1204056 	✓					✓		
Mechanism Mecanismo	0502080 	✓					✓		
	0502090 		✓	✓	✓	✓			✓

List of Pillars-Rollers-Roofs
 Rungen-Rollen-Dach Aufstellung
 Tabla de aplicaciones Pilares-Carros-Techos

Ref. Art-Nr.	Pillar	Versus	Autocar	Edscha	Sesam
0502261	XL Telescopic (0505518)	VS nano; VS alto 150; VS Feralo; VS EURO	A small; A slim light	E-volumen; Hubdach/ Lift CS-Lite plus 175; Vp profi alu	S slimliner large
0502262	XL Telescopic (0505518)	Vs duo; mycro		E standar; E standar CS 125; E standar CSLite plus 125; E Maut/ Toll CS-Lite- plus 110	S Slimliner small; S Slimliner medium
0502263	XL Telescopic (0505518)	VS quadro; VS plano		E standar CS 115	S multiliner combi 2004; S Flatiner
0502270	XL Fix-front (0505550)	VS nano; VS alto 150; VS Feralo; VS EURO	A small; A slim light	E-volumen; Hubdach/ Lift CS-Lite plus 175; Vp profi alu	S slimliner large
0502271	XL Fix-front (0505550)	Vs duo; mycro		E standar; E standar CS 125; E standar CSLite plus 125; E Maut/ Toll CS-Lite- plus 110	S Slimliner small; S Slimliner medium
0502277	L Standard (0505010/14)	VS nano; VS alto 150; VS Feralo; VS EURO	A small; A slim light	E-volumen; Hubdach/Lift CS-Lite plus 175; Vp profi alu	S slimliner large
0502278	L Standard (0505010/14)	Vs duo; mycro		E standar; E standar CS 125; E standar CS-lite plus 125; E Maut/Toll CS-Liteplus 110	S Slimliner small; S Slimliner medium
0502279	L Standard (0505010/14)	Vs Kubus; VS quadro; VS plano	A std	E standar CS 115	S multiliner combi 2004; S Multiliner mix 2004; S Flatiner
0502286	L Fix-front (0505109)	VS nano; VS alto 150; VS Feralo; VS EURO	A small; A slim light	E-volumen; Hubdach/ Lift CS-Li- te plus 175; Vp profi alu	S slimliner large
0502287	Double Deck - Fix - (0505204)	VS nano; VS alto 150; VS Feralo; VS EURO			
0502288	Double Deck - Elev. - (0505202)	VS nano; VS alto 150; VS Feralo; VS EURO			
0502293	XL Standard (0505130)	VS nano; VS alto 150; VS Feralo; VS EURO	A small; A slim light	E-volumen; Hubdach/ Lift CS-Li- te plus 175; Vp profi alu	S slimliner large
0502294	XL Standard (0505130)	Vs duo; mycro		E standar; E standar CS 125; E standar CSLite plus 125; E Maut/ Toll CS-Lite- plus 110	S Slimliner small; S Slimliner medium
0502295	XL Standard (0505130)	VS quadro; VS plano		E standar CS 115	S multiliner combi 2004; S Flatiner



ADAICO PILLAR COMPONENTS / RUNGENBAUTEILE ADAICO / COMPONENTES PILAR ADAICO

PILLARS AND ACCESSORIES / RUNGEN UND ZUBEHÖR / PILARES Y ACCESORIOS

Modular Pillar Top Roller W44
Modular Runge Laufwagen W44
Carro Pilar Modular Recto A44

NEW

Ref	Kg	Mat	Sup/Finish Acabado	Col	Lot
0508030	1.3	STEEL	KTL	●	1

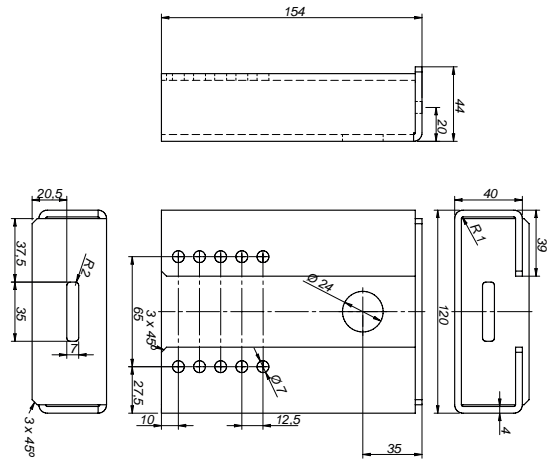
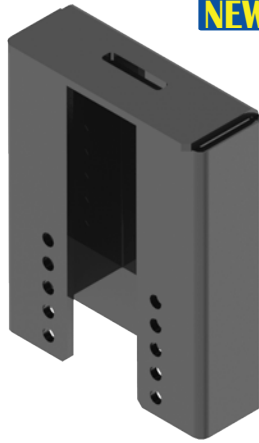

Modular Pillar Top Roller W54
Modular Runge Laufwagen W54
Carro Pilar Modular Recto A54

NEW

Ref	Kg	Mat	Sup/Finish Acabado	Col	Lot
0508032	1.4	STEEL	KTL	●	1

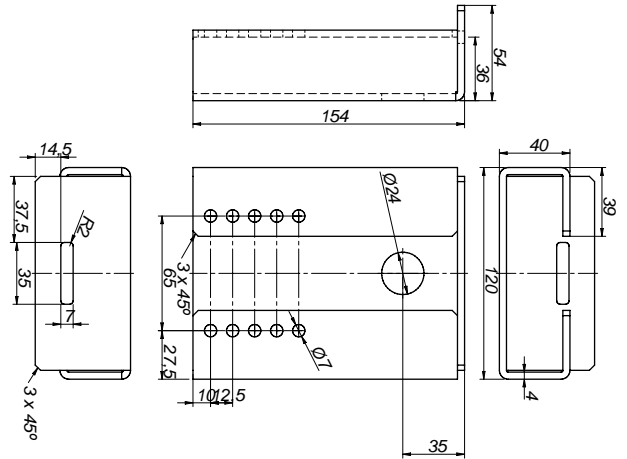

Modular Pillar Top Roller q35
Modular Runge Laufwagen q35
Carro Pilar Modular Quiebro 35

NEW

Ref	Kg	Mat	Sup/Finish Acabado	Col	Lot
0508034	1.2	STEEL	KTL	●	1

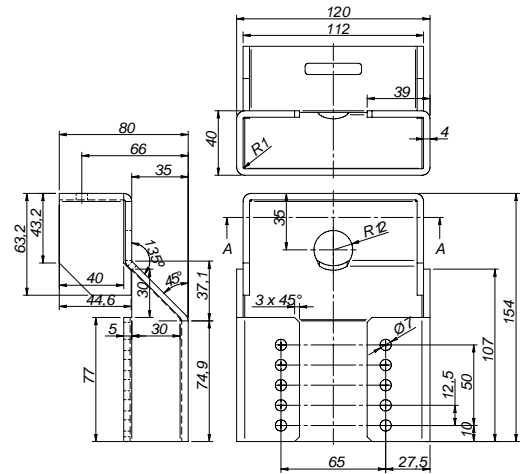
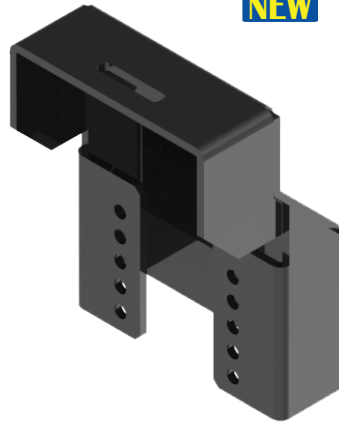

Pillar Top Roller $\varnothing 24 \times 30$
Runge-Laufwagen $\varnothing 24 \times 30$
Carro Pilar $\varnothing 24 \times 30$

Ref	Kg	Mat	Sup/Finish Acabado	Col	Lot
0502043	3	STEEL	KTL	●	1

Roller 0801140
Carro 0801140

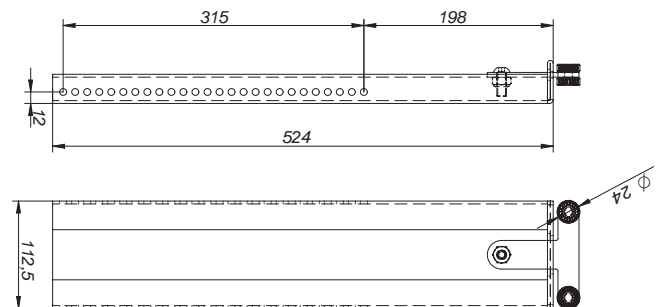

"E" Type beveled Roller Ø35x30
"E" abgeschrägtes Roller Ø35x30
Ruleta Tipo "E" rueda Biselada Ø35x30

Ref	Kg	Mat	Sup/Finish Acabado	Lot
0502019	0.7	STEEL	Zn	1

Nylon Roller
Rodamiento Nylon

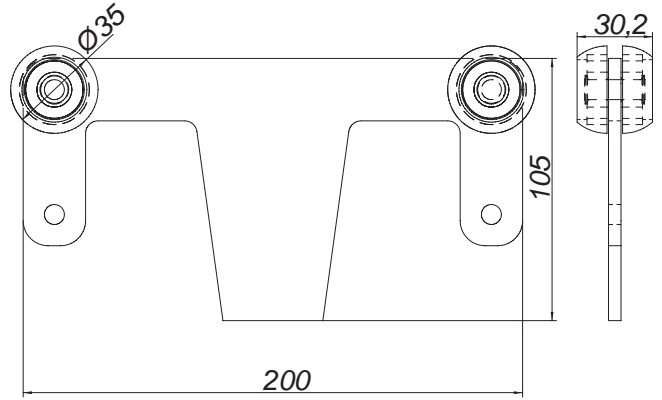

"E" Type Steel Roller Ø24X24
"E" Stahl Roller Ø24X24
Ruleta Tipo "E" Rueda Acero Ø24X24

Ref	Kg	Lot
0502031	0.7	1

Steel Roller
Rodamiento Acero

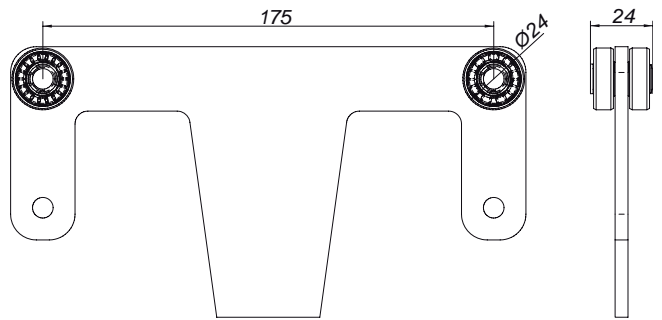

Double Roller Ø35x30 for Modular Pillar Carriage
Roller Doppel Ø35x30 für Modular Rungen-Laufwagen
Ruleta Doble Ø35x30 para Carro de Pilar Modular

Ref	Kg	Mat	Lot
0801139	0.3	STEEL	1

Nylon Roller
Rodamiento Nylon

NEW

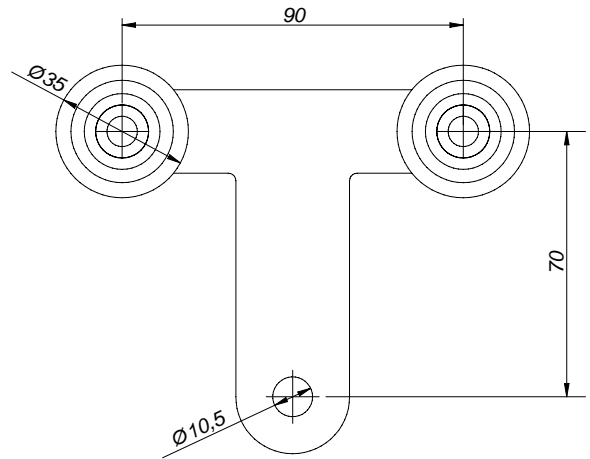

Double Roller Ø24x22 for Modular Pillar Carriage
Roller Doppel Ø24x22 für Modular Rungen-Laufwagen
Ruleta Doble Ø24x22 para Carro de Pilar Modular

Ref	Kg	Mat	Lot
0801140	0.26	STEEL	1

Steel Roller
Rodamiento Acero

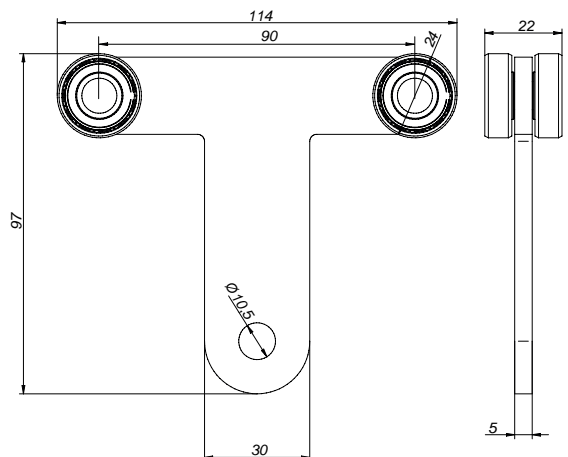



ADAICO PILLAR COMPONENTS / RUNGENBAUTEILE ADAICO / COMPONENTES PILAR ADAICO

PILLARS AND ACCESSORIES / RUNGEN UND ZUBEHÖR / PILARES Y ACCESORIOS

Pillar Top Roller KTF EDSCHA
Runge Laufwagen KTF EDSCHA
Carro de Pilar c/CTF rueda EDSCHA

Ref	Kg	Mat	Sup/Finish Acabado	Col	Lot
0502024	4.97	STEEL	KTL	●	1

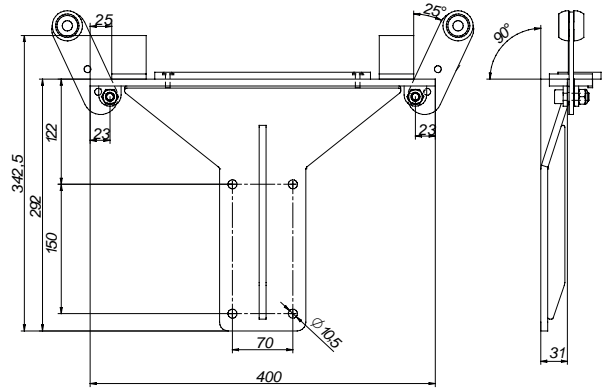

Modular Pillar Elevation Kit
Modular Runge Hubdach Set
Kit Elevación Pilar Modular

Ref	Kg	Mat	Lot
0508600	0.6	STEEL	1

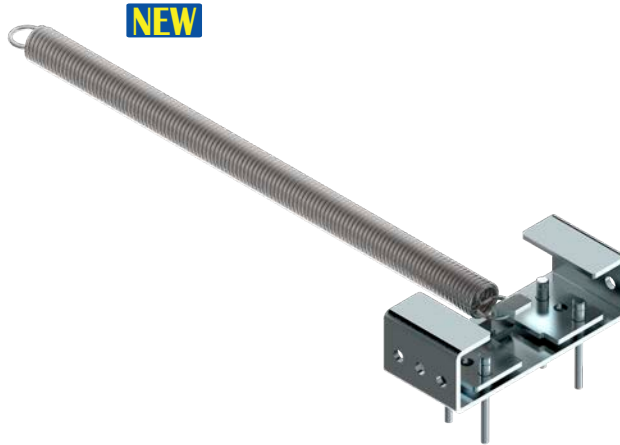

Modular Pillar Elevation Kit with Fixfront 2.0
Modular Runge Hubdach Set mit Fixfront 2.0
Kit Elevación Pilar Modular con Fix Front 2.0

Ref	Kg	Mat	Lot
0508500	1	STEEL	1

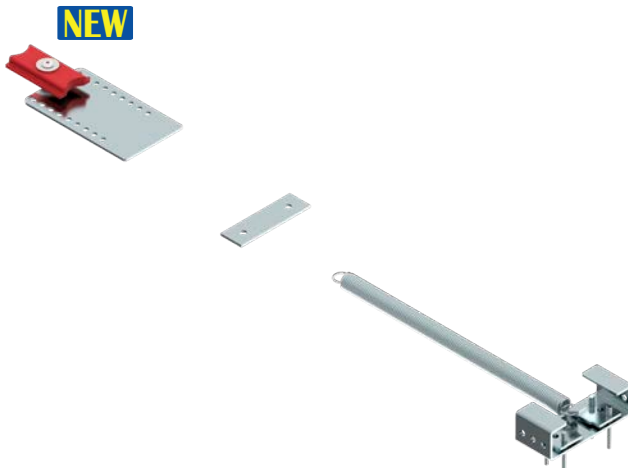

Modular Pillar Blocking Strip
Modular Runge Verriegelungsplatte
Fleje de Bloqueo Pilar Modular

Ref	Kg	Mat	Sup/Finish Acabado	Thickn. Espesor	Lot
0508090	0.08	STEEL	Zn	1.5	1

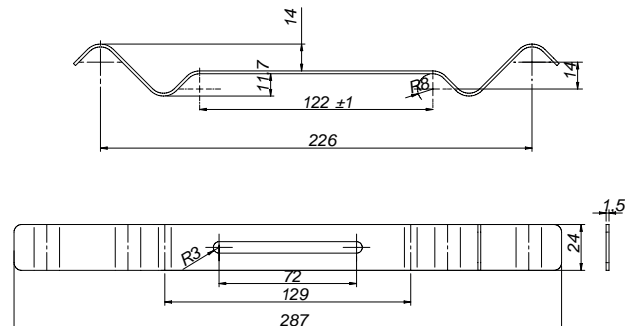
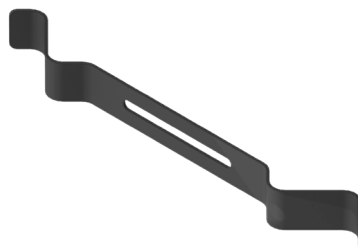

Latch Fix-front 2.0 for Modular Pillar
Riegel Fix-front 2.0 für Modular Runge
Fijación Fix-front 2.0 para Pilar Modular

NEW

Ref	Kg	Lot
0502061	0.09	1

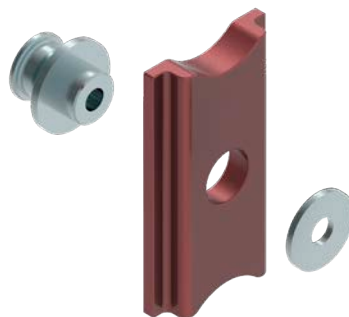

Latch for Fix-front Pillar with cable
Riegel für Fix-front Runge mit Kabel
Bulón de fijación para Pilar Fix-front con Eslinga

NEW

Ref	Kg	Lot
0502063	0.09	1

With rubber washer | With cable
Con arandela de goma | Con eslinga

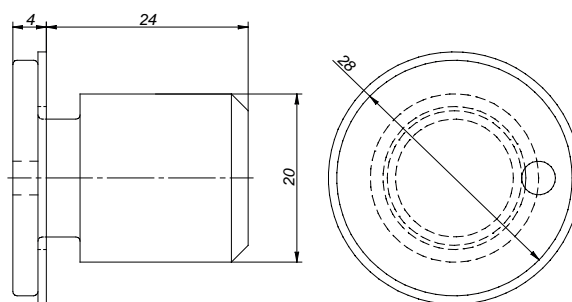
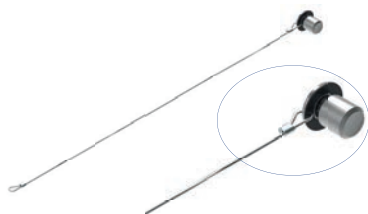

Timberholders to Rivet L=120 KTF
Stecklattentasche zum Anieten L=120 KTL
Caja Cartolilla para Remachar L=120 c/KTF

Ref	Kg	Mat	Sup/Finish Acabado	Col	Pos	Lot
0502212	0.28	STEEL	KTL	●	▶	10
0502213	0.28	STEEL	KTL	●	▶	10

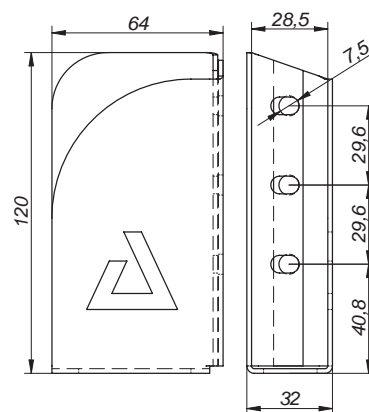

Ⓛ

Timberholder L=120
Stecklattentasche L=120
Caja Cartolilla L=120

Ref	Kg	Mat	Pos	Lot
0502542	0.16	STEEL	▶	1
0502543	0.16	STEEL	▶	1

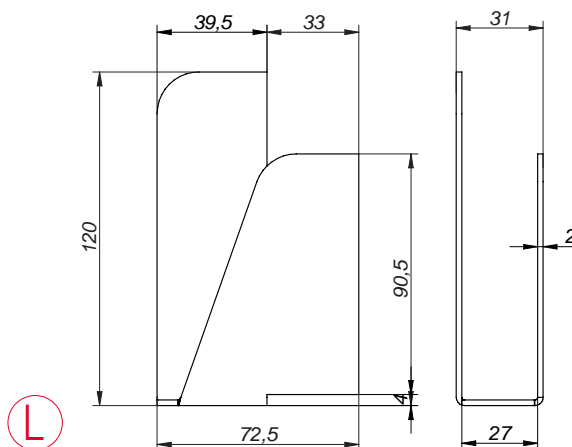
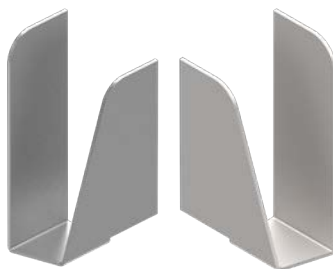

Ⓛ



ADAICO PILLAR COMPONENTS / RUNGENBAUTEILE ADAICO / COMPONENTES PILAR ADAICO

PILLARS AND ACCESSORIES / RUNGEN UND ZUBEHÖR / PILARES Y ACCESORIOS

Timberholder to Weld 130x50
Lattentasche zum Anschweißen 130x50
Caja Cartolilla para Soldar 130x50

Ref	Kg	Mat	Sup/Finish Acabado	Lot
0502209	0.26	STEEL	Zn	10

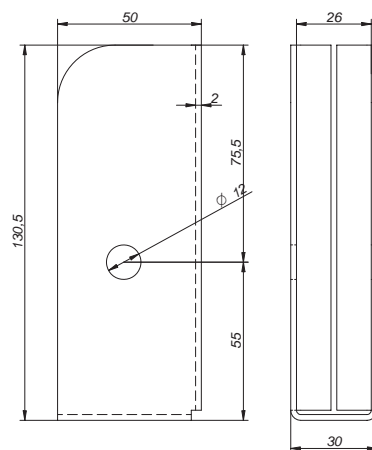

Timberholder to Rivet L=600, Modular Pillar
Stecklattentasche zum Annieten L=600, Modular Runge
Caja Cartolilla Pilar Modular para Remachar L=600

NEW

Ref	Kg	Sup/Finish Acabado	Col	Pos	Lot
0502544	0.9	KTL	●	👁	1
0502545	0.9	KTL	●	👁	1

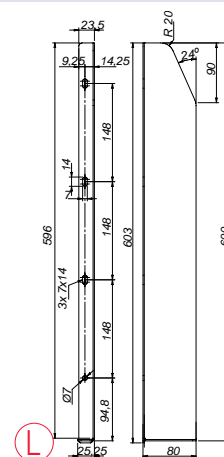
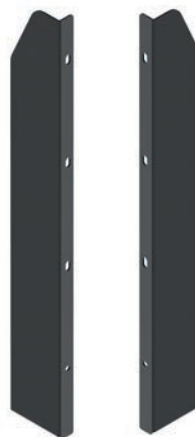

Timberholder to Rivet L=460 KTF
Stecklattentasche zum Annieten L=460 KTL
Caja Cartolilla para remachar L=460 c/KTF

Ref	Kg	Sup/Finish Acabado	Col	Pos	Lot
0502526	0.6	KTL	●	👁	1
0502527	0.6	KTL	●	👁	1

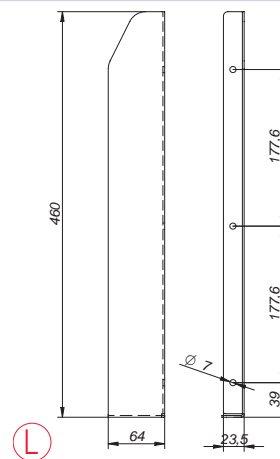

Timberholders to Rivet L=600 KTF
Stecklattentasche zum Annieten L=600 KTL
Caja Cartolilla para Remachar L=600 c/KTF

Ref	Kg	Mat	Sup/Finish Acabado	Col	Pos	Lot
0502214	1.43	STEEL	KTL	●	👁	1
0502215	1.43	STEEL	KTL	●	👁	1

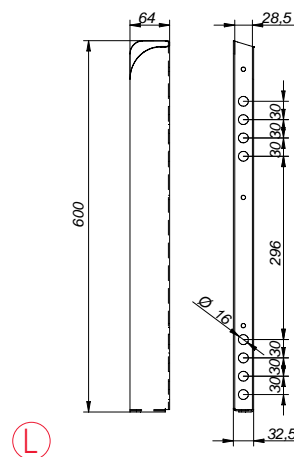

ADAICO PILLAR COMPONENTS / RUNGENBAUTEILE ADAICO / COMPONENTES PILAR ADAICO



PILLARS AND ACCESSORIES / RUNGEN UND ZUBEHÖR / PILARES Y ACCESORIOS

Timberholder to Weld L=600
Lattentasche zum Schweißen L=600
Caja Cartolilla para Soldar L=600

Ref	Kg	Mat	Pos	Thickn. Espesor	Lot
0502206	0.33	STEEL		2	1
0502218	0.33	STEEL		2	1

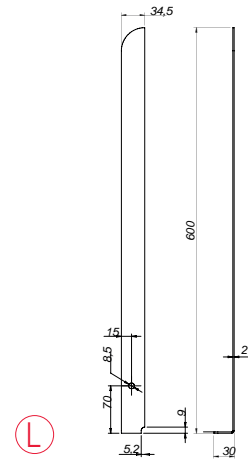
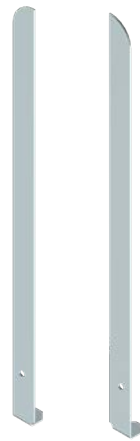

Timberholder L=390
Stecklattentasche L=390
Caja Cartolilla L=390

Ref	Kg	Mat	Pos	Lot
0502540	0.66	STEEL		1
0502541	0.66	STEEL		1

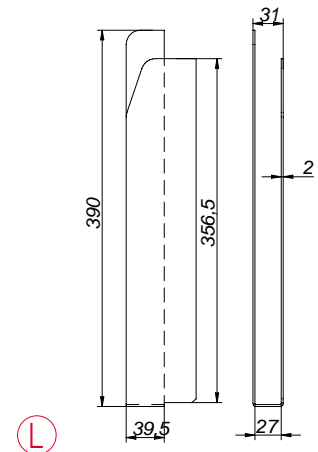
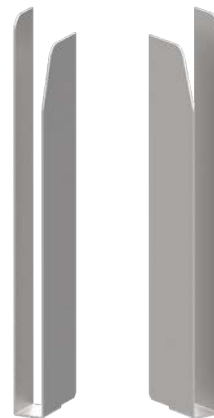

Sideboard Lock Pocket 23x32
Rungentasche für Langwegverschluss 23x32
Uña Cierre Cartola 23x32

Ref	Kg	Mat	Lot
1204056	0.05	STEEL	10

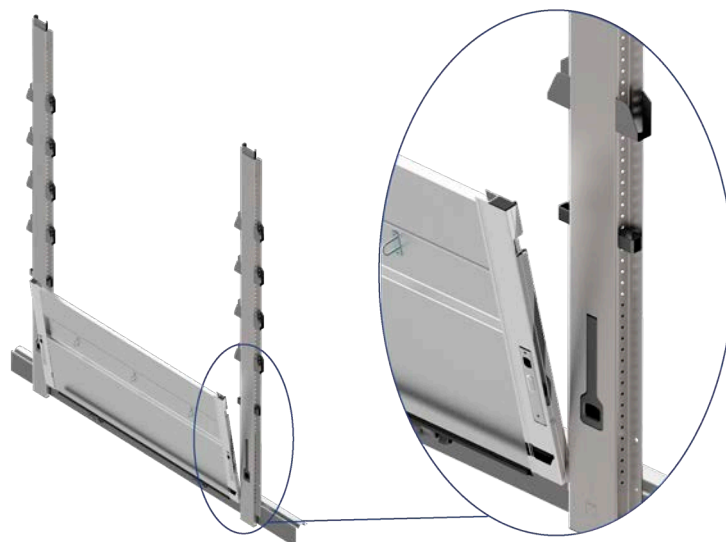
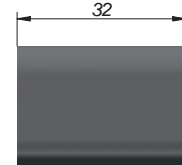
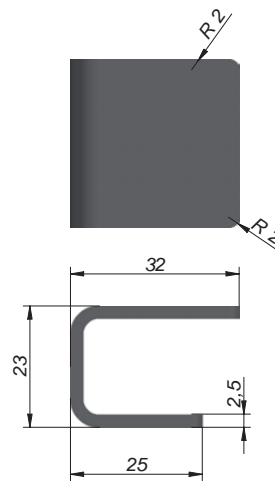



ADAICO PILLAR COMPONENTS / RUNGENBAUTEILE ADAICO / COMPONENTES PILAR ADAICO

PILLARS AND ACCESSORIES / RUNGEN UND ZUBEHÖR / PILARES Y ACCESORIOS

Sideboard Lock Pocket for Modular Pillar
Modular Runge Langwegverschluss Tasche
Uña Cierre Cartola Pilar Modular

NEW

Ref	Kg	Mat	Lot
1204009	0.3	STEEL	1

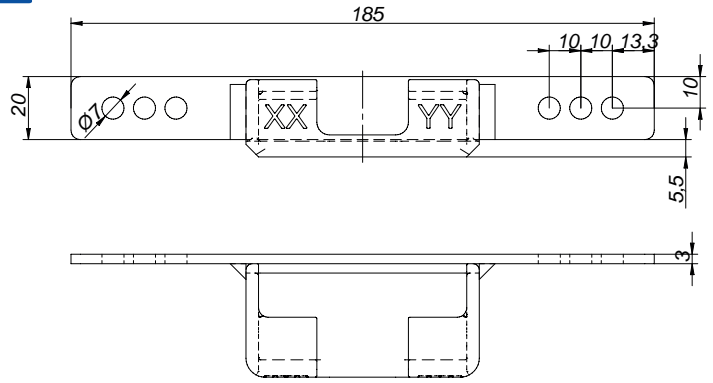
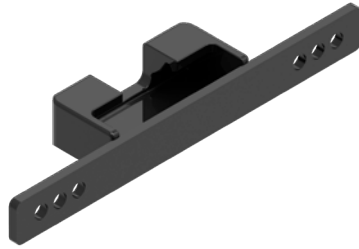

Sideboard Lock for Modular Pillar
Modular Runge Langwegverschluss
Cierre Cartola Pilar Modular

NEW

Ref	Kg	Mat	Sup/Finish Acabado	Lot
0508070	0.2	STEEL	KTL	1

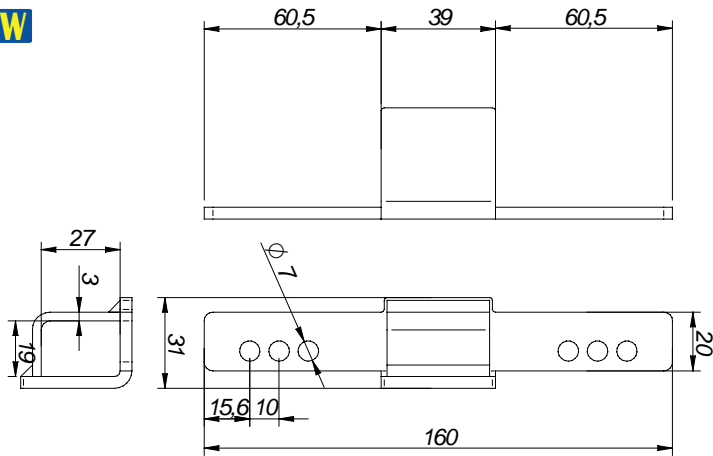
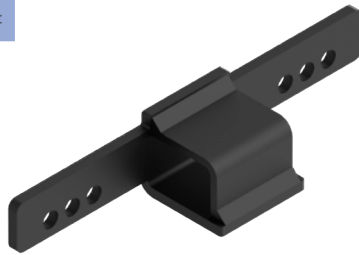

Pillar Pin with Bolt
Rungekeil mit Schrauben
Cuña Llanta c/Tornillo

Ref	Kg	Mat	A	B	Lot
0502310	6.53	STEEL	110	150	1
0502312	5.15	STEEL	90	150	1
0502314	4.35	STEEL	70	1	

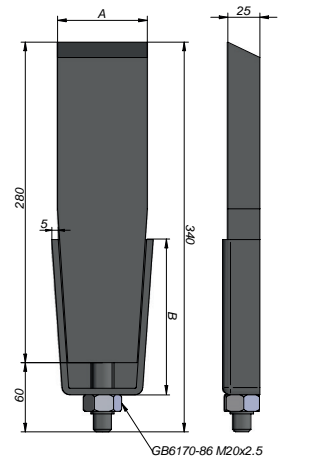
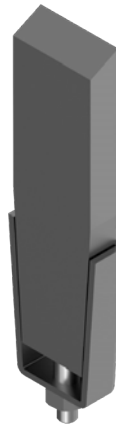

Forged Pillar Pocket and Pin
Rungekeil
Abrazadera-Cuña Forjada

Ref	Kg	Mat	A	B	C	D	E	Part	Lot
0502350	4	Forged	60	400	-	-	-		1
0502355	1	Forged	-	-	135	120	39		1
0502360	3.1	Forged	60	290	-	-	-		1
0502365	0.87	Forged	-	-	115	102	36		1
0502370	1.6	Forged	48	240	-	-	-		1
0502375	0.58	Forged	-	-	95	85	32		1
0502377	1.6	Forged	40	200	-	-	-		1
0502379	0.5	Forged	-	-	88	76	28		1

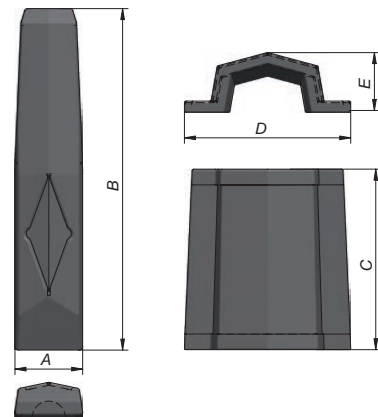

Chassishook to weld
Rungenlager zum Anschweißen
Soporte de Pilar para soldar

Ref	Kg	Mat	Sup/Finish Acabado	Col	Lot
0502002	1.08	STEEL			2
0506002	1.08	STEEL	KTL	●	2

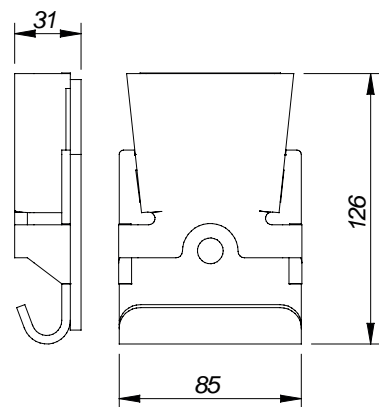

Chassishook to Screw
Rungenlager zum Anschrauben
Soporte de Pilar para atornillar

Ref	Kg	Mat	Sup/Finish Acabado	Col	Lot
0506003	1.06	STEEL	KTL	●	2
0506005	1.06	STEEL			2

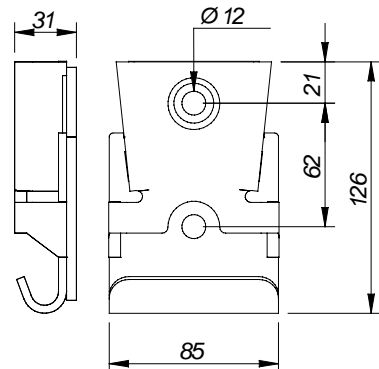

Small Chassishook to Screw
Kleines Rungenlager zum Anschrauben
Soporte Reducido para atornillar

Ref	Kg	Mat	Sup/Finish Acabado	Col	Lot
0506024	0.66	STEEL	KTL	●	1

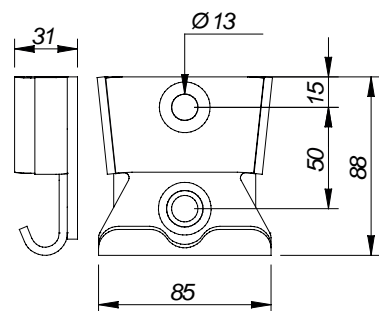

Modular Pillar Small Chassishook
Kleines Rungenlager zum Modular Rungen
Soporte Reducido Pilar Modular

Ref	Kg	Mat	Sup/Finish Acabado	Col	Lot
0508060	0.2	STEEL	KTL	●	1

NEW

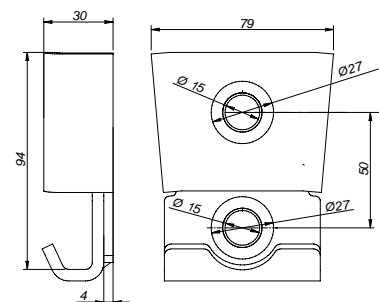
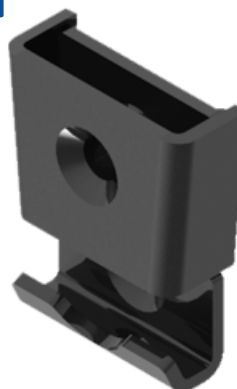



ADAICO PILLAR COMPONENTS / RUNGENBAUTEILE ADAICO / COMPONENTES PILAR ADAICO

PILLARS AND ACCESSORIES / RUNGEN UND ZUBEHÖR / PILARES Y ACCESORIOS

Standard Cassishook Pillar Mechanism Lever
 Rungenmechanik Standard Rungenlager
 Mecanismo Pilar, Soporte Standard

Ref	Kg	Mat	Article	Lot
0502080	6.92	STEEL	Complet Mechanism Mecanismo Completo	1
0502007	0.79	STEEL	Pillar Handle Manilla de Pilar	1
0502008	2.89	STEEL	Lever	1
0502009	0.23	Forged	Tapa Basculante Pillar Cap	1
0502070	0.01	STEEL	Spring Muelle	12

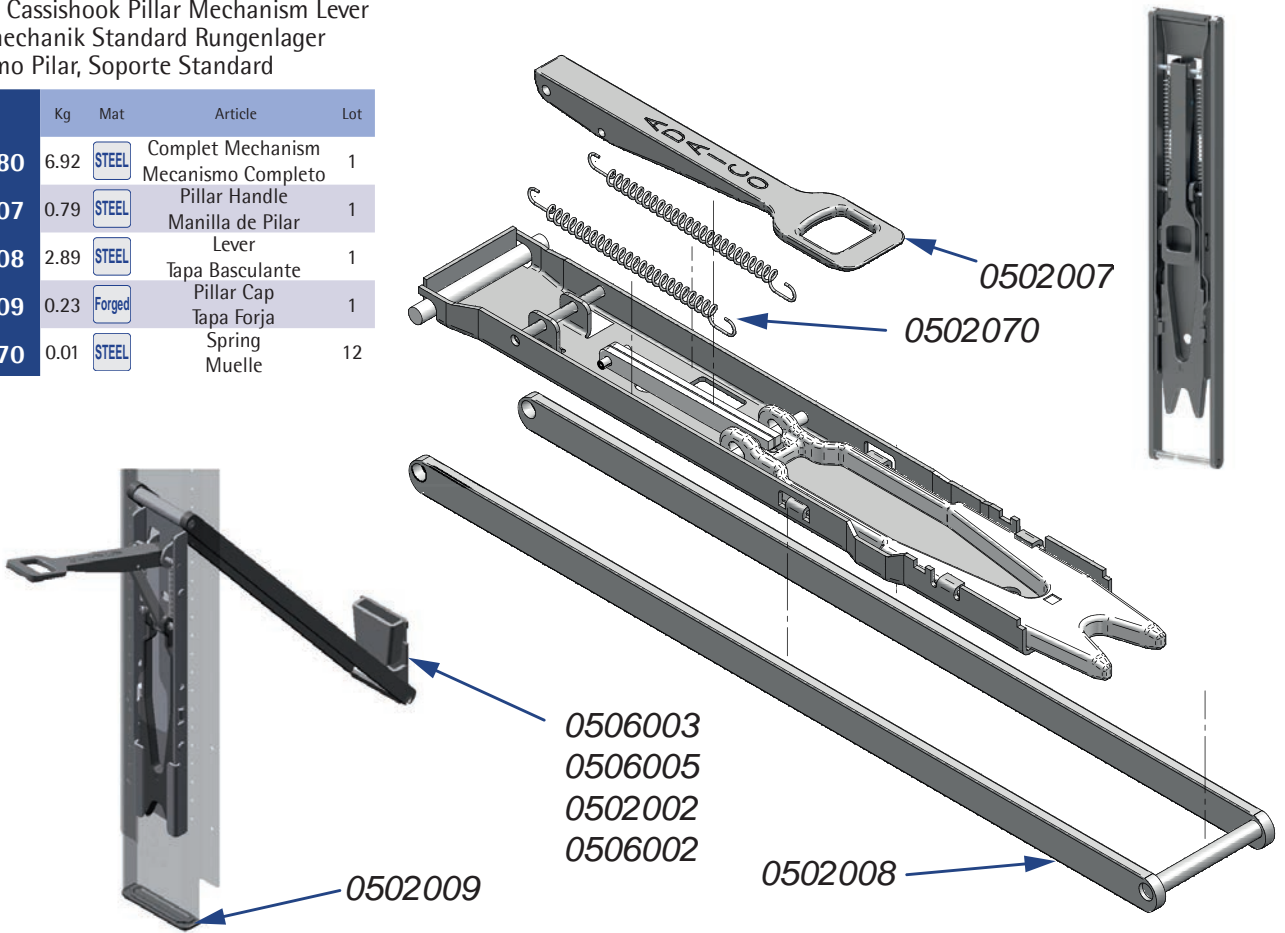

Reduced Cassishook Pillar Mechanism Lever
 Rungenmechanik Klein Rungenlager
 Mecanismo Pilar, Soporte Reducido

Ref	Kg	Mat	Article	Lot
0502090	5.1	STEEL	Complet Mechanism Mecanismo Completo	1
0502007	0.79	STEEL	Pillar Handle Manilla de Pilar	1
0502088	1.44	STEEL	Lever	1
0502009	0.23	Forged	Tapa Basculante Pillar Cap	1
0502070	0.01	STEEL	Spring Muelle	12

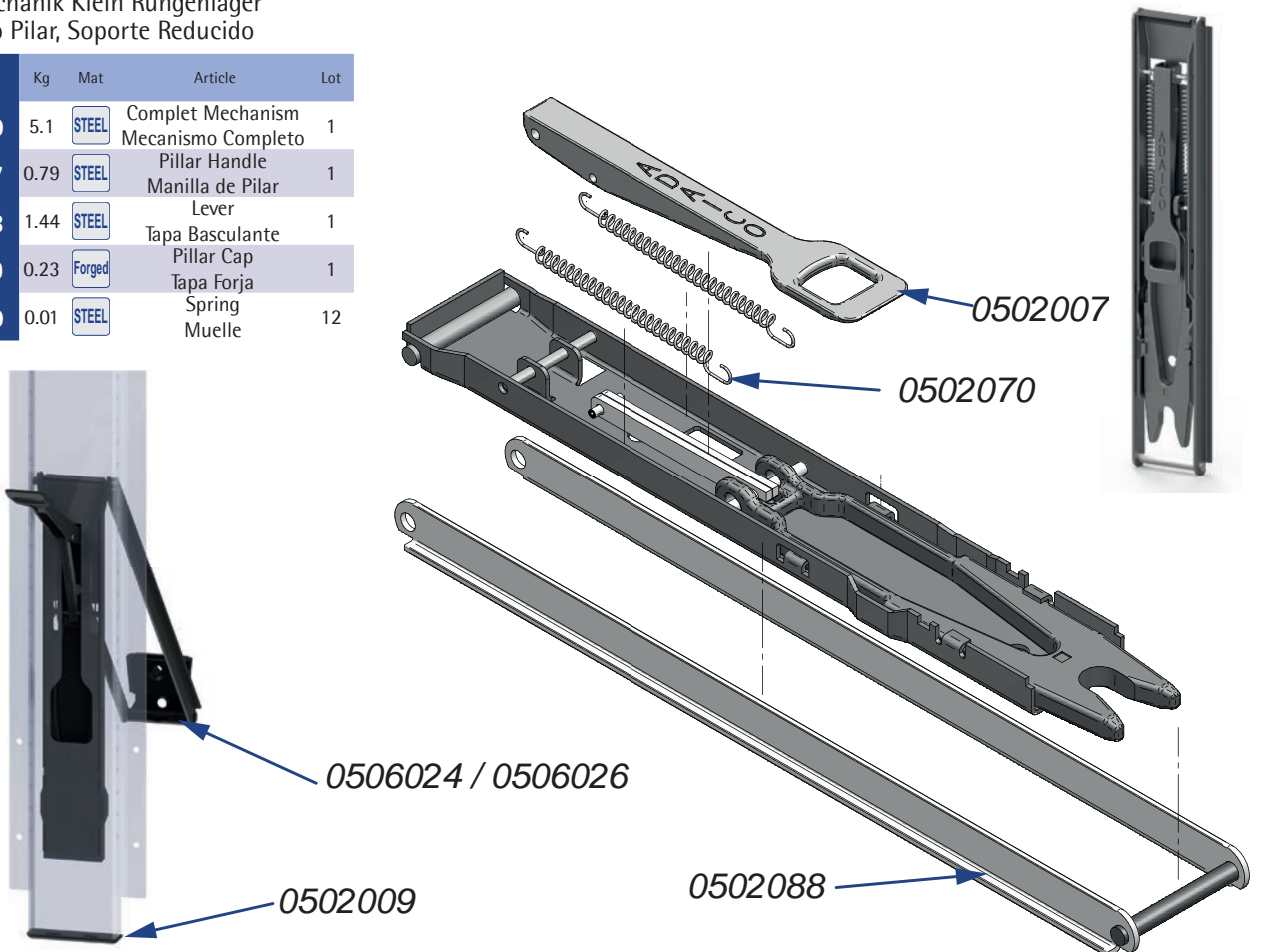

Sistemas de Elevación Techo
Roof Elevation Systems
Système d'élévation de Toit
Hubdach Systeme
Sistemas de Elevação de Carga

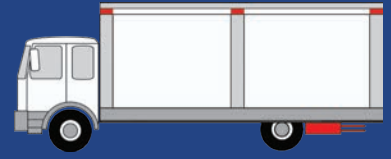

Hidráulico

Hydraulic

Hydraulique

Hydraulisch

Hidráulico



pag. 38-40

Hidroneumático

Hydropneumatic

Hydropneumatique

Hydropneumatisch

Hidropneumático

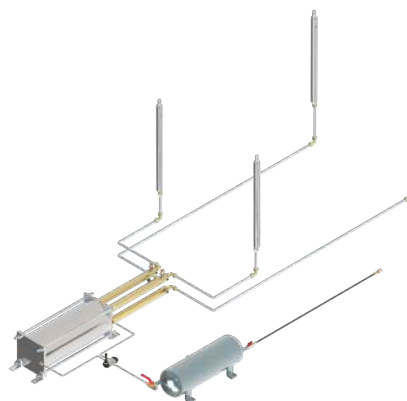

pag. 41-46

ADALIFTER

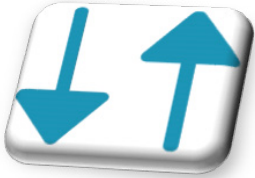
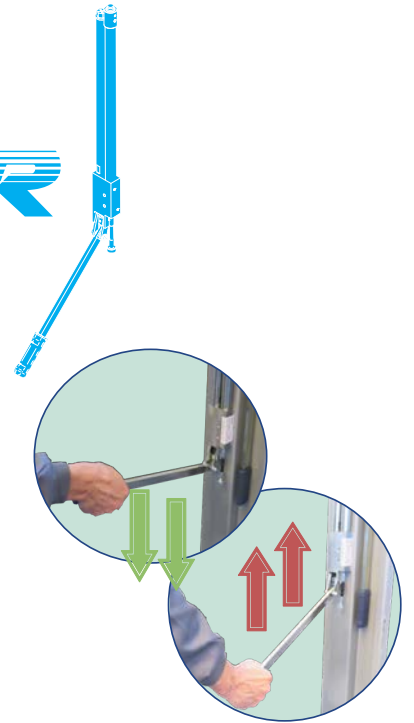

✓ DOUBLE EFFECT / DOBLE EFECTO

2 times faster because it elevates both when the handle is pushed up and down.
2 veces más rápido al elevarse tanto al accionar la manilla hacia arriba como hacia abajo.



✓ HYDRAULIC / HYDRÁULICO

Perfect functioning both at high and low ambient temperature.
Perfecto funcionamiento tanto a baja como a alta temperatura ambiente.



✓ SYMMETRICAL SYSTEM / SIMÉTRICO

The same system can be installed at the left or right side of the truck body.
Fijación a la carrocería en ambos sentidos, sin necesidad de guardar mano izquierda o derecha.

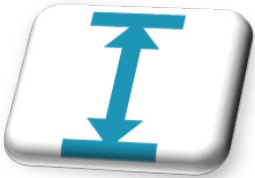

✓ ELEVATION RANGE / RANGO DE ALTURAS

STANDARD (450mm. / 500mm.)
COAXIAL (450mm. / 500mm. / 600mm.)

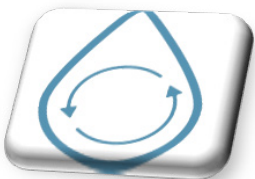

✓ OIL CIRCUIT SEALED / CIRCUITO DE ACEITE SELLADO

Perfectly sealed oil circuit and manual purge valve.
Circuito de aceite perfectamente cerrado y con posibilidad de purgado manual.



✓ ROBUST / ROBUSTO

Successfully passed the most exigent tests required by our OEM customers
Superados los más exigentes test de vida exigidos por nuestros clientes OEM.



HYDRAULIC ELEVATION SYSTEM / HYDRAULISCHES HUBSYSTEM / SIST DE ELEVACIÓN HIDRÁULICO



ADA-LIFTER Hydraulic Pump Double Effect
Hydraulik Pumpe ADA-LIFTER Doppel-Effekt
Bomba Hidráulica ADA-LIFTER Doble Efecto

Ref	Kg	A	B	C	Elev.	Lot
0601086	3.57	450	1032	533	450 mm.	1
0601085	3.6	500	1082	583	500 mm.	1



Ref. 0601093

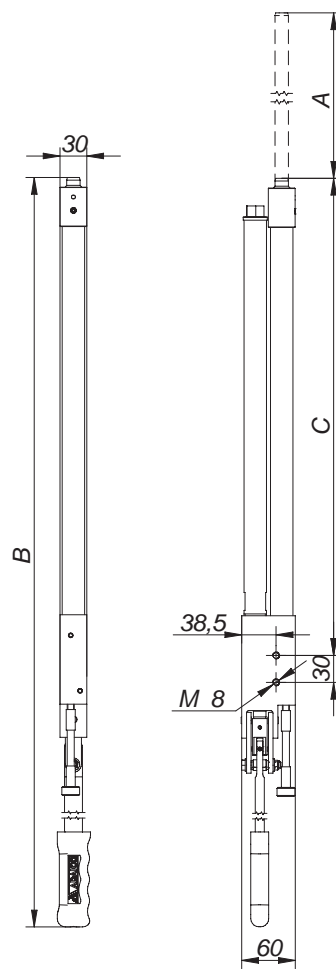

Pillar Extension Set for ADA-LIFTER Pump 0601085/86
Verlängerungs-Kit für ADA-LIFTER Pumpe 0601085/86
Alargadera para Bomba ADA-LIFTER 0601085/86

Ref	Kg	Lot
0601088	8.5	1

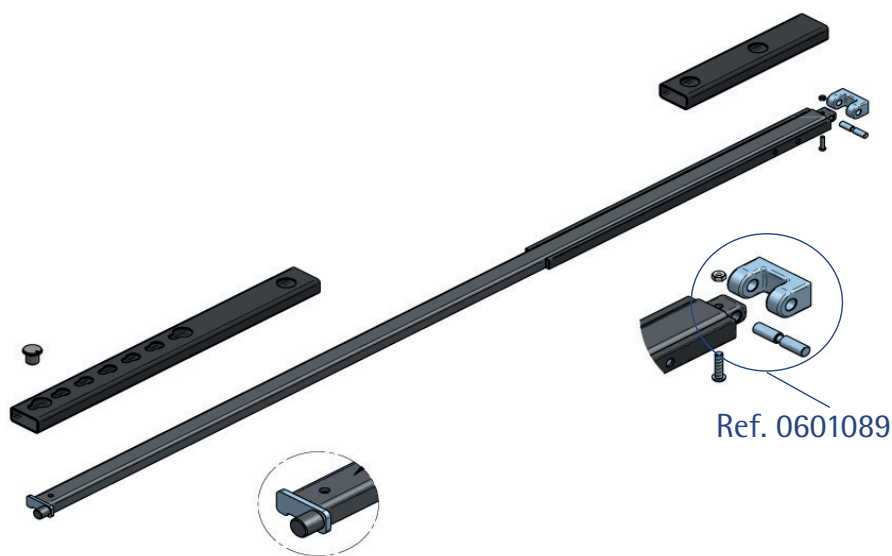

Ref. 0601089

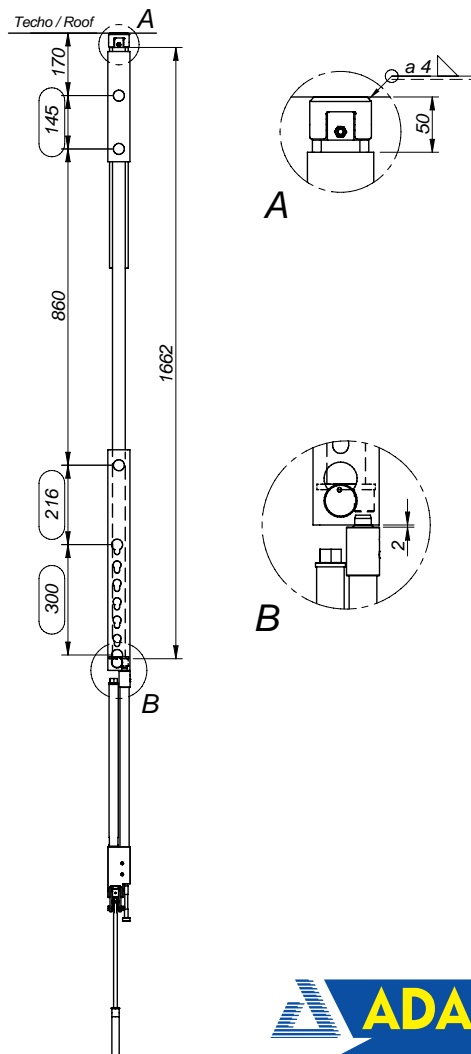

ROOF ELEVATION SYSTEMS / HUBDACHSYSTEME / SISTEMAS DE ELEVACIÓN TECHO



HYDRAULIC ELEVATION SYSTEM / HYDRAULISCHES HUBSYSTEM / SIST DE ELEVACIÓN HIDRÁULICO

ROOF ELEVATION SYSTEMS / HUBDACHSYSTEME / SISTEMAS DE ELEVACIÓN TECHO

ADA-LIFTER Hydraulic COAXIAL Pump Double Effect
Hydraulik KOAXIAL pumpe ADA-LIFTER Doppel-Effekt
Bomba Hidráulica COAXIAL ADA-LIFTER Doble Efecto

NEW

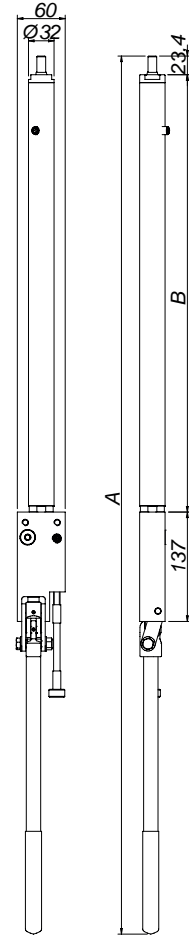

Ref	Kg	A	B	Article	Lot
0601072	3.1	1100	548.2	450 mm.	1
0601074	3.2	1150	598.2	500 mm.	1
0601076	3.5	1250	698.2	600 mm.	1

Double Effect | Material: Aluminum body and steel tubes
Doble Efecto | Material: Cuerpo en aluminio y tubos de acero

HYDROPNEUMATIC SYSTEM *SISTEMA HIDRONEUMATICO*

✓ Automatic Roof Elevation / *Elevación Automática de Techo*



✓ Robust and Durable / *Robusto y Durable*

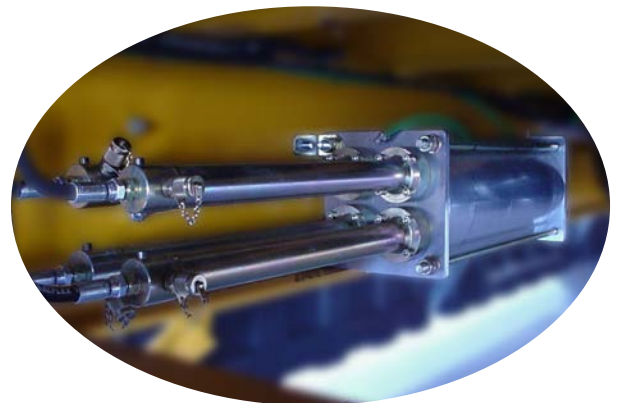
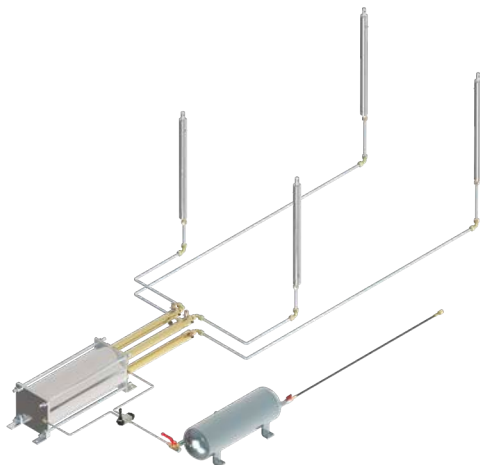



HYDROPNEUMATIC SYSTEM

SISTEMA HIDRONEUMÁTICO



✓ FAST ELEVATION / RÁPIDA ELEVACIÓN

The roof is lifted in a quick and smooth way.
El techo se eleva de forma rápida y suave

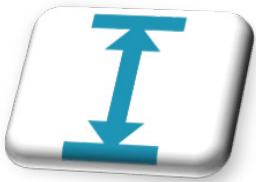

✓ ELEVATION RANGE / RANGO DE ALTURAS

450mm. / 600mm. / 800mm. / 1.000mm.



✓ ROBUST / ROBUSTO

It is a very strong system which grants a perfect functionality for many years.
Es un sistema muy robusto que garantiza una perfecta funcionalidad durante muchos años.



✓ EASY & CONVENIENT / FÁCIL & CÓMODO

Just by pulling the handle, the system automatically elevates the roof.
Tan solo accionando el mando, el sistema eleva automáticamente el techo.

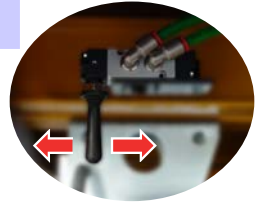

✓ SIMPLICITY / SENCILLEZ

It uses the compressed air supply of the truck itself. No any additional force supply needed.
Utiliza el suministro de aire comprimido del camion. No es necesario ningún motor o equipo adicional.



✓ PERFECT PERFORMANCE / FUNCIONAMIENTO PERFECTO

The system lifts the 4 corners of the roof at the same time, thanks to its high-powered output.
El sistema eleva las 4 esquinas del techo al mismo tiempo, gracias a su gran potencia de elevación.



✓ AVOID BREAKDOWNS / EVITA AVERÍAS

No movable electrical parts are required.
No son necesarios accesorios eléctricos adicionales.

FAST & EASY! / ¡RÁPIDO Y FÁCIL!



Control Kit / Kit de mandos

Simple and intuitive.
Simple e intuitivo.

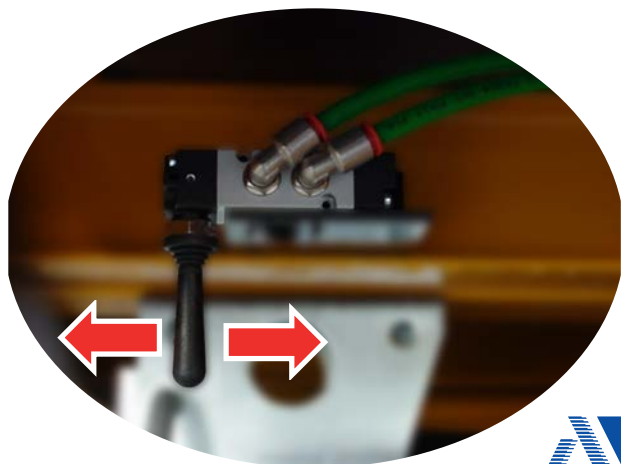

HYDROPNEUMATIC SYSTEM / HYDROPNEUMATISCHES HUBSYSTEM / SISTEMA HIDRONEUMÁTICO

ROOF ELEVATION SYSTEMS / HUBDACHSYSTEME / SISTEMAS DE ELEVACIÓN TECHO

Ref. Art-Nr.	Description Descripción	Elevation (mm.) / Elevación (mm.)					
		4 Cylindres 4 Cilindros				6 Cylindres 6 Cilindros	
		450	600	800	1000	600	1000
0601020	Hydropneumatic Pump (4 cyl- 450 mm.) <i>Bomba Hidroneumática (4 cil.- 450 mm.)</i>	1					
0601030	Hydropneumatic Pump (4 cyl- 600 mm.) <i>Bomba Hidroneumática (4 cil.- 600 mm.)</i>		1				
0601035	Hydropneumatic Pump (4 cyl- 800 mm.) <i>Bomba Hidroneumática (4 cil.- 800 mm.)</i>			1			
0601040	Hydropneumatic Pump (4 cyl- 1.000 mm.) <i>Bomba Hidroneumática (4 cil.- 1.000 mm.)</i>				1		
0601042	Hydropneumatic Pump (6 cyl- 1.000 mm.) <i>Bomba Hidroneumática (6 cil.- 1.000 mm.)</i>						1
0601050	Hydropneumatic Pump (6 cyl- 600 mm.) <i>Bomba Hidroneumática (6 cil.- 600 mm.)</i>					1	
0601110	Cylinder (450 mm. [Ø35]) <i>Cilindro (450 mm. [Ø35])</i>	4					
0601120	Cylinder (600 mm. [Ø35]) <i>Cilindro (600 mm. [Ø35])</i>		4			4	
0601140	Cylinder (800 mm. [Ø35]) <i>Cilindro (800 mm. [Ø35])</i>			4			
0601150	Cylinder (1.000 mm. [Ø40]) <i>Cilindro (1.000 mm. [Ø40])</i>				4		
0601121	Cylinder (600 mm. [Ø45]) <i>Cilindro (600 mm. [Ø45])</i>					2	
0601162	Cylinder (1.000 mm. [Ø45]) <i>Zylinder (1.000 mm. [Ø45])</i>						2
0601164	Cylinder (1.000 mm. [Ø35]) <i>Cilindro (1.000 mm. [Ø35])</i>						4
0601230	Oil Tank <i>Depósito de Aceite</i>	1	1	1	1	1	1
0601210	Accessories kit (4 cyl.) <i>Kit de Accesorios (4 cil.)</i>	1	1	1	1		
0601214	Accessories kit (6 cyl.) <i>Kit de Accesorios (4 cil.)</i>					1	1

						
+	+	+	+	+	+	+
					 	 
+	+	+	+	+	+	+
						
+	+	+	+	+	+	+
						

HYDROPNEUMATIC SYSTEM / HYDROPNEUMATISCHES HUBSYSTEM / SISTEMA HIDRONEUMÁTICO



Hydropneumatic Pump
Hydropneumatische Pumpe
Bomba Hidroneumática

Ref	Kg	A	B	Article	Lot
0601020	33	504	533	4 cyl. (4x0601110) - Elev. 450 mm.	1
0601030	38	654	683	4 cyl. (4x0601120) - Elev. 600 mm.	1
0601050	53	699	683	6 cyl. (4x0601120 + 2x0601121) Elev. 1000 mm.	1
0601035	42	854	883	4 cyl. (4x0601140) - Elev. 800 mm.	1
0601040	60	1054	1083	4 cyl. (4x0601150) - Elev. 1000 mm.	1
0601042	69	1099	1083	6 cyl. (4x0601164 + 2x0601162) Elev. 1000 mm.	1

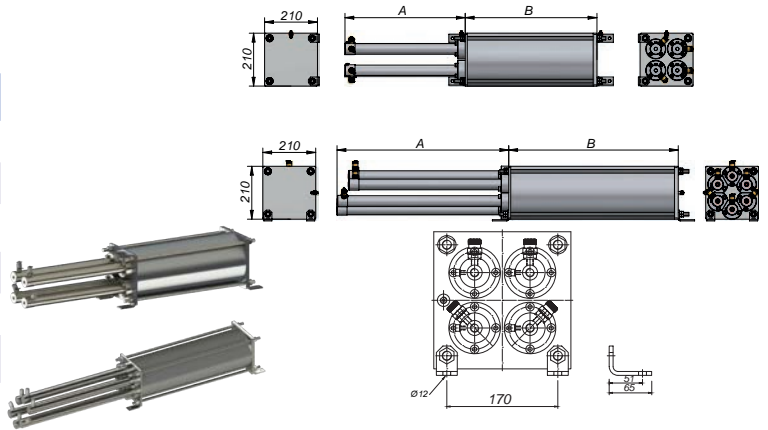

Cylinder
Zylinder
Cilindro

Ref	Kg	Mat	A	B	C	Article	Lot
0601110	3.4	STEEL	450	605	Ø35	Elev. 450 mm.	1
0601120	4.2	STEEL	600	755	Ø35	Elev. 600 mm.	1
0601121	8	STEEL	600	755	Ø45	Elev. 600 mm.	1
0601140	5.5	STEEL	800	955	Ø35	Elev. 800 mm.	1
0601164	6.5	STEEL	1000	1155	Ø35	Elev. 1.000 mm.	1
0601150	8.8	STEEL	1000	1155	Ø40	Elev. 1.000 mm.	1
0601162	11.5	STEEL	1000	1155	Ø45	Elev. 1.000 mm.	1

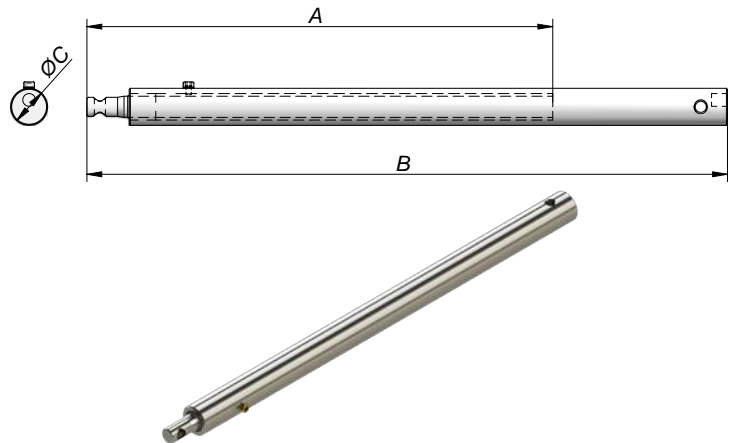

Oil tank
Öltank
Calderín hidroneumático

Ref	Kg	Mat	Sup/Finish Acabado	Cap.L	Lot
0601230	9.97	STEEL	Galv	12	1

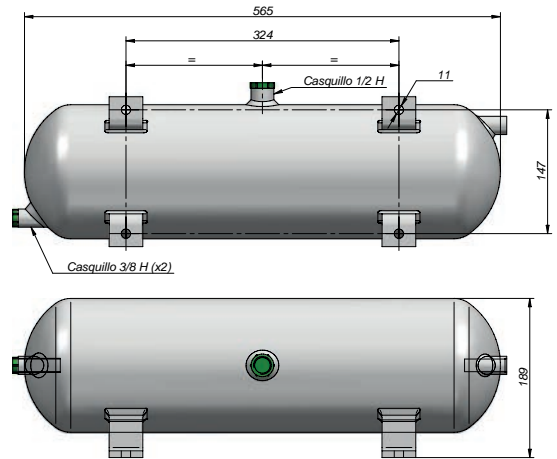
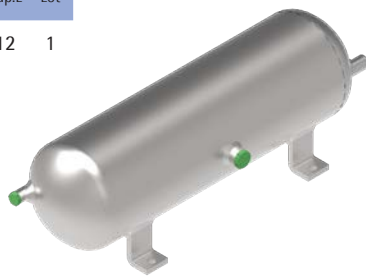

Control Valve Hydropneumatic
Steuventil Hydropneumatisch
Válvula Hidroneumática

Ref	Kg	Strength Fuerza	Lot
0601216	0.16	20 N	1

-0,9 ÷ 10 bar | 500 Nl/min

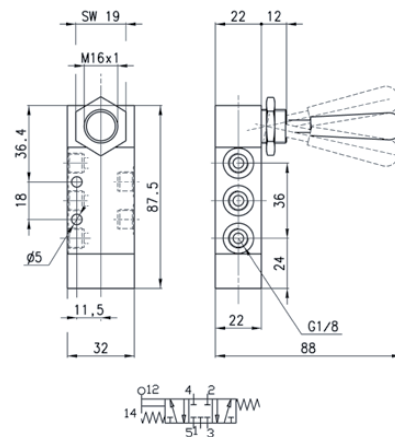

ROOF ELEVATION SYSTEMS / HUBDACHSYSTEME / SISTEMAS DE ELEVACIÓN TECHO



HYDROPNEUMATIC SYSTEM / HYDROPNEUMATISCHES HUBSYSTEM / SISTEMA HIDRONEUMÁTICO

ROOF ELEVATION SYSTEMS / HUBDACHSYSTEME / SISTEMAS DE ELEVACIÓN TECHO

Accessories Kit
Zubehör-Kit
Kit de Mandos

Ref	Kg	Article	Lot
0601210	2	For 4 Cylinders Pump Para Bomba de 4 cilindros	1
0601214	2.56	For 6 Cylinders Pump Para Bomba de 6 cilindros	1

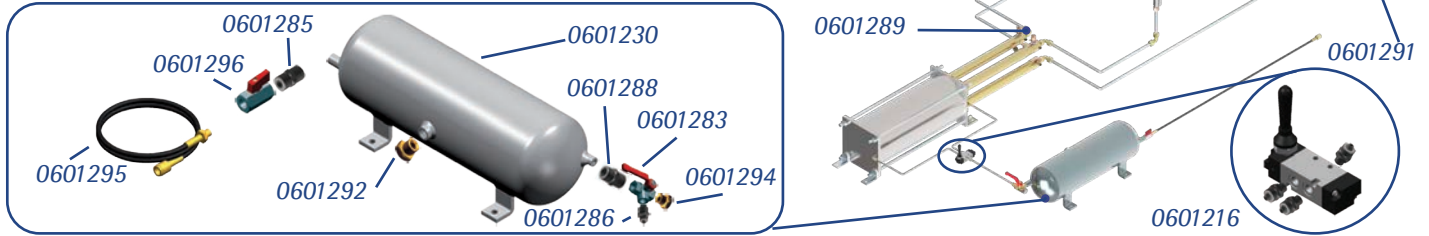

Ref. Art-Nr.	Description Beschreibung Descripción		Lote	Kit 0601210 (4 cyl.)	Kit 0601214 (6 cyl.)
0601216	Control Valve <i>Steuerventil</i> Válvula		1	1	1
0601260	Raccord 12 mm. 1/4" <i>Nippel 12 mm. 1/4"</i> Racor 12 mm. 1/4"		4	4	6
0601283	3 way Key 3/8" <i>3 Kugelhahn 3/8"</i> Llave 3 Vias 3/8"		1	1	1
0601292	Pump Lid 1/2" <i>Deckel 1/2"</i> Tapón Bomba 1/2"		1	1	1
0601285	Raccord M-M 3/8" BSP <i>Nippel M-M 3/8" BSP</i> Racor Unión M-M 3/8" BSP		1	1	1
0601286	Raccord 3/8" Ø8 <i>Nippel 3/8" Ø8</i> Racor Semirápido 3/8" Ø8		1	1	1
0601287	Raccord 1/8" Ø8 <i>Nippel 1/8" Ø8</i> Racor Semirápido 1/8" Ø8		1	3	3
0601288	Raccord M-M 1/4" <i>Nippel M-M 1/4"</i> Racor Unión M-M 1/4"		1	1	1
0601289	Swivel Elbow Ø12L + Raccord M1/4" Ø12L <i>Kniestück + Nippel M1/4" Ø12L</i> Codo 90° Orientable Serie Ø12L + Racor M1/4" Ø12		4	4	6
0601274	Washer 1/4" <i>Unterlagscheibe 1/4"</i> Arandela 1/4"		20	8	12
0601291	Raccord 90° <i>Nippel 90°</i> Racor Ángulo Recto		4	4	6
0601294	Pump Lid 3/8" <i>Deckel 3/8"</i> Taco Bomba 3/8"		1	1	1
0601295	Connection Pipe <i>Verbindungsschlauch</i> Latiguillo		1	1	1
0601296	2 Way Key 1/4" H-H <i>Verteilerventil 1/4" H-H</i> Llave Hembra 1/4" H-H		1	1	1

ADA-SLIDER



ADA-SLIDER



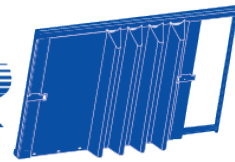

✓ System of curtain sides for delivery trucks *Sistema de lona corredera para vehículo de reparto*



✓ XL Certified / *Certificado XL*

UNE-EN 12642:2006



✓ Light, resistant and easy to install *Ligero, resistente y de fácil instalación*



AEV AUTOMOTIVE, S.L.
Area Log. Ind. Plaza
C/ Mamfredonia, 10 - Nave 5
50197 - ZARAGOZA
CIF: B-99178683

INFORME DE ENSAYO
TEST REPORT
Nº de Informe: 19-0429A
Report number :

Materia: UNE-EN 12642:2006
Relativa a: FIJACION DE LA CARGA EN VEHICULOS DE CARRETERA
ESTRUCTURA DE CARROCERIA DE LOS VEHICULOS COMERCIALES
REQUISITOS MINIMOS
With regard to : SECURING OF CARGO ON ROAD VEHICLES
BODY STRUCTURE OF COMMERCIAL VEHICLES
MINIMUM REQUIREMENTS
Tipo de ensayo: APARTADO 5.3.4. RESISTENCIA DE LAS PAREDES LATERALES
Test type: SECTION 5.3.4 OF STRENGTH OF SIDE WALLS

PART 1.- GENERALIDADES
PART 1.- GENERALITIES

1.1.- SOLICITANTE: ADAICO TRUCK & TRAILER, S.L.U.
APPLICANT : POL. EMPRESARIAL BOROA, SECTOR UI-13 - 2: PARC. 4 - 2B4.
BOROA - AMOREBIETA - 48340 - BIZKAIA - ESPAÑA.

1.2.- MUESTRA ENSAYADA:
TESTED SAMPLE

Marca: ADAICO

Mark:

Tipo o identificación: ADA SLIDER CLASSIC

Type or identification:

Descripción: Pared lateral compuesta por lonas correderas de PVC sobre perfil superior e inferior de aluminio con cierre de tensado delantero y trasero provistos de cerraduras de seguridad. Ver apartado 3.2
Description: Lateral wall composed of PVC sliding railings on upper and lower aluminum profile with front and rear tensioning device provided with safety locks. See section 3.2

PART 2.- CONCLUSIONES
PART 2.- CONCLUSIONS

La PARED LATERAL objeto de este informe CUMPLE / ~~NO CUMPLE~~ con los requisitos relativos a la resistencia de estructuras de carrocería reforzada CODIGO XL ensayada de acuerdo al apartado 5.3.4. de la norma UNE-EN 12642:2006, habiendo superado con éxito los siguientes requisitos:
The SIDE WALL gathered in this report FULFILLS / ~~DOES NOT FULFILL~~ this requirement for strength reinforced body structures XL CODE tested according to paragraph 5.3.4. of the EN 12642:2006 standard, having passed the following conditions:

Componente	Requisito ensayo	Carga útil autorizada (P)	Carga de ensayo
Component	Test Requirement XL Code	Authorized Payload (P)	Load Test
Pared lateral	0,4 P	10.000 daN	4.000 daN
Side Wall			

Así mismo de conformidad con el apartado 4 de la norma UNE-EN 12642:2006, la PARED LATERAL objeto de este informe se considera adecuada para su utilización en carrocerías reforzadas código XL. According to paragraph 4 of the UNE-EN 12642:2006 standard, the SIDE WALL gathered in this report is suitable for using with reinforced body structures code XL.

Realizado por / Carried out by :

El Técnico responsable
Technician in charge of test
Fermin Sebastián Bazán

El Director Técnico
Technical Manager :
Javier Fle Allerta

Zaragoza, a 29 de Abril de 2019
Zaragoza, on April 29, 2019

LOS RESULTADOS QUE APARECEN EN ESTE INFORME SE REFIEREN A LA MUESTRA
RESULTS WHICH APPEAR ON THIS REPORT REFER ONLY TO TESTED SAMPLE
PICHEN LA REPRODUCCION PARCIAL DE ESTE DOCUMENTO SIN LA AUTORIZACION ESCRITA DE AEV AUTOMOTIVES S.L.
IS FORBIDDEN THE PARTIAL REPRODUCTION OF THIS DOCUMENT WITHOUT AEV AUTOMOTIVE S.L. WRITTEN CONSENT

SIN ENAYADA .
IZACION ESCRITA DE AEV AUTOMOTIVES S.L.
Formato POE-12642-XL-A-02 / POE-12642-XL-A-02 Format

Pág. 1 / 4
Edition 1 / 4

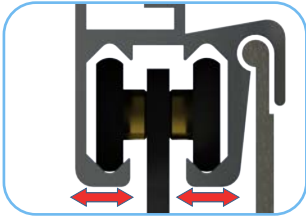
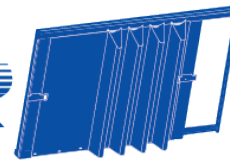

✓ **FAST CURTAIN OPENING**
RÁPIDA APERTURA DE LONAS

The patented horizontal profile allows an smooth sliding and avoids blockages.
Perfil horizontal patentado que evita bloqueos y permite un deslizamiento suave.

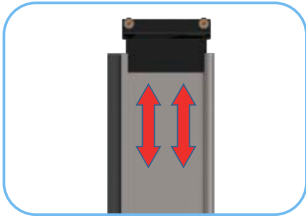

✓ **TELESCOPIC ALUMINUM DOORS**
PUERTAS DE ALUMINIO TELESCÓPICAS

Unique system to ensure absence of problems when the truck box is subjected to torsions (Ex. up on the sidewalk)
Sistema único para asegurar la apertura fácil cuando la caja del camión está sometida a torsiones (Ej. Subido a una acera).



✓ **ALWAYS PERFECT ADVERTISING**
PUBLICIDAD SIEMPRE PERFECTA

The door locks acts as a tensioner, ensuring that the curtain is always offering the best image as possible.
Cierre de puerta que actua como tensor, para contar con una lona que ofrezca siempre la mejor imagen.



✓ **PROTECTION AGAINST BUMPS**
PROTECCIÓN ANTI-GOLPES

The main function of the lower PVC profile is to protect the horizontal aluminum track from continuous bumps from the forklift during the loading/unloading process.
El perfil de PVC inferior cumple la función principal de proteger al perfil de aluminio de los continuos golpes en los procesos de carga y descarga.

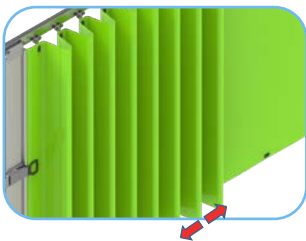

✓ **FAST AND EASY CURTAIN FOLDING**
PLEGADO FÁCIL Y RÁPIDO

The patented outfolding system allows a perfect folding and a correct sliding of the curtain across its way.
El sistema outfolding (patentado) permite un perfecto plegado y un correcto deslizamiento de la lona a lo largo de su recorrido.

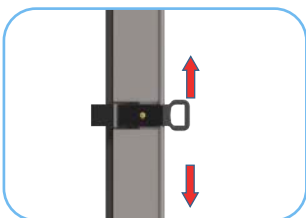









✓ **HEIGHT ADJUSTABLE DOOR LOCKS**
CIERRE AJUSTABLE EN ALTURA

The locks are designed to allow fixing at any height, at customer's wish.
Cierre diseñado de tal manera que permite ser atornillado a cualquier altura, en función de la necesidad del cliente.





Components / Komponenten / Componentes

Ref. Art-Nr.	Description Beschreibung Descripción		Longitud Sistema / Longueur Système / Comprimento Sistema							
			Lote	4 m.	4,5 m.	5 m.	5,5 m.	6 m.	6,5 m.	7 m.
1402404	Aluminium horizontal profile 7 m. <i>Hor. Aluminiumprofil 7 m.</i> Perfil aluminio horizontal 7 m.		1						4	4
1402406	Aluminium horizontal profile 6 m. <i>Hor. Aluminiumprofil 6 m.</i> Perfil aluminio horizontal 6 m.		1				4	4		
1402408	Aluminium horizontal profile 5 m. <i>Hor. Aluminiumprofil 5 m.</i> Perfil aluminio horizontal 5 m.		1		4	4				
1402410	Aluminium horizontal profile 4 m. <i>Hor. Aluminiumprofil 4 m.</i> Perfil aluminio horizontal 4 m.		1	4						
1404170	PVC pelmet 14 m. <i>PVC Gummi 14 m.</i> Perfil PVC 14 m.		1	1	1	1	1	1	1	1
1703064	PVC side bumper 3 m. <i>PVC Seitenprofil 3 m.</i> Perfil PVC lateral 3 m.		1	3	3	4	4	4	5	5
0802113	Up curtain roller <i>Gardinenroller Oben</i> Carro superior lona		10	18	20	22	24	26	28	30
0802133	Down curtain roller <i>Gardinenroller Unten</i> Carro inferior lona		10	18	20	22	24	26	28	30
0901251	Pack 10 un. Curtain-roller plastic backplate <i>Pack 10 un. Befestigungsplatte für Rollen</i> Pack 10 uds. Sujeción lona-carro plástico		1	4	5	5	5	6	6	6
1402431 1402429 1402427	Aluminium vertical profile <i>Vertikal Aluminiumprofil</i> Perfil aluminio vertical - h=2,8 m. (1402431) - h=2,4 m. (1402429) - h=2,1 m. (1402427)		1	4	4	4	4	4	4	4
1201375	Door lock <i>Türverschluss</i> Cierre puerta		1	4	4	4	4	4	4	4
1201372	"Tens-Lock" Door lock <i>Türverschluss "Tens-Lock"</i> Cierre puerta "Tens-Lock"		1	4	4	4	4	4	4	4
1201385	Door holder <i>Türhalte</i> Resbalón puertas		4	4	4	4	4	4	4	4
1404202	PVC door Pelmet (10 m.) <i>PVC Rollband profil (10 m.)</i> Perfil PVC puerta (10 m.)		1	1	1	1	1	1	1	1
0802122	Up door roller <i>Oberer Türroller</i> Carro superior puerta		1	4	4	4	4	4	4	4
0802153	Down door roller (right) <i>Unterer Tür Roller (rechts)</i> Carro inferior puerta (derecho)		1	2	2	2	2	2	2	2
0802143	Down door Roller (left) <i>Unterer Tür Roller (links)</i> Carro inferior puerta (izquierdo)		1	2	2	2	2	2	2	2
1602020	Handle PVC <i>Griff PVC</i> Asa PVC		2	4	4	4	4	4	4	4
0902061	Pack 10 un. Outfolding 1		1	3	3	3	3	3	4	4
0902064	Outfolding 2 (2 m.)		2	2	2	2	2	2	2	2

*The quantities will be adjusted to the batches at the time of placing an order.
Um die Bestellungen aufzunehmen, werden die Mengen an die Lotgröße angepasst.
Para hacer los pedidos, se ajustarán las cantidades a los lotes.



Components / Komponenten / Componentes





✓ **Large Fleets of Delivery Trucks**
Grandes Flotas de Camiones de Reparto

Great cost reduction, thanks to time savings in delivery.

Gran reducción de costes, gracias al ahorro de tiempo en el reparto.



✓ Double Lock (High-Sided Vehicles)
Cierre Doble (Vehículos Altos)

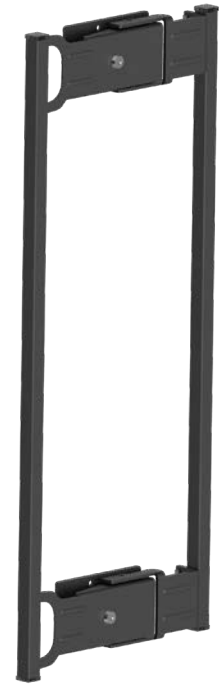

✓ Electromobility
Electromovilidad



✓ Other uses
Otras Aplicaciones



Special Transportation
Transporte Especial



✓ Instructions for choosing curtains: GRAMMAGE & DIMENSIONS
Instrucciones para la elección de lona: GRAMAJE Y DIMENSIONES

Recommended Curtain: Panamá 900 grs. provide with the top rollers, buckles, and unfolding system already assembled.
Lona recomendada: Panamá 900 grs. Servidas con los carros superiores, hebillas y el sistema outfolding ya montados.

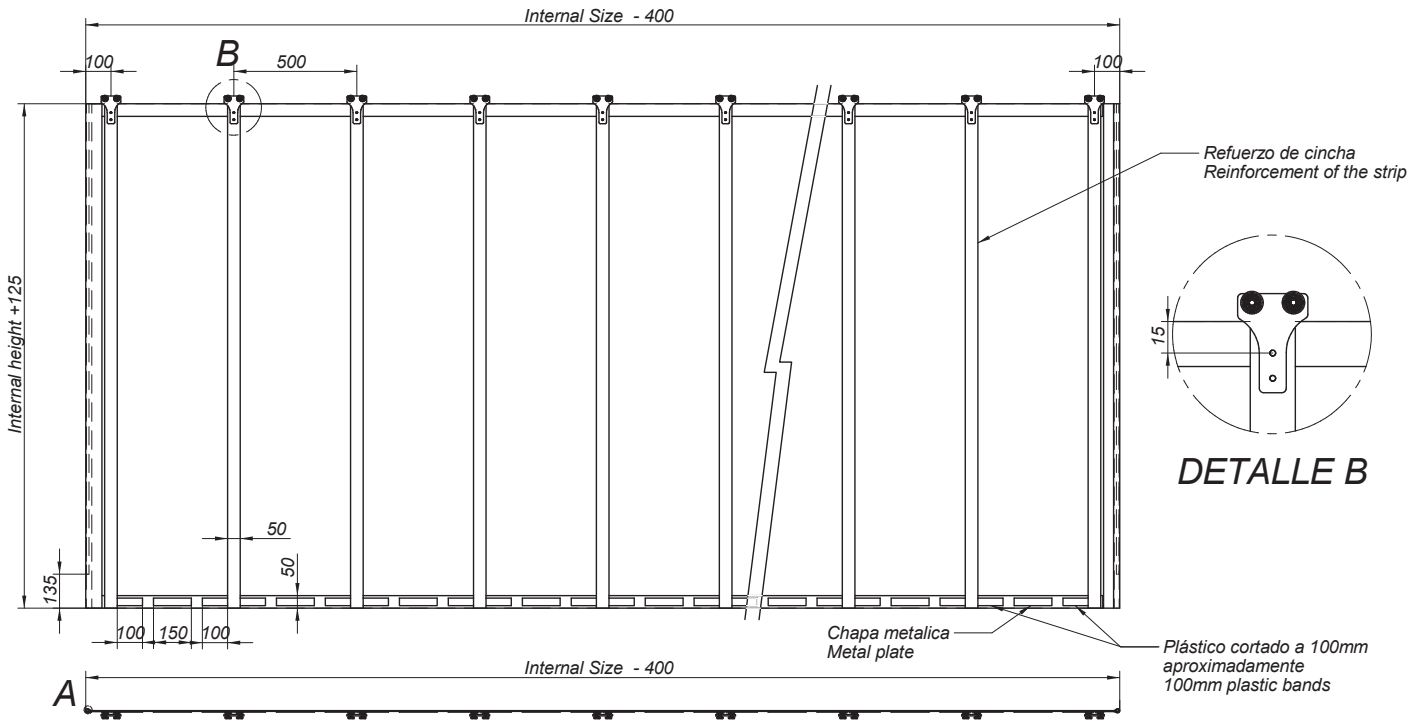

La longitud de la lona se mide desde este extremo
It measures the length of the curtain from this point

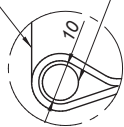

DETALLE A

Macarrón de PVC debe ser 135 mm mas corta que la altura de la lona
The PVC rod must be 135mm shorter than the curtain height

LENGTH OF THE CURTAIN = L (inner) - 400 mm.
Ejemplo = 5.000 mm. (A) - 400 mm. = 4.600 mm.
HEIGHT OF THE CURTAIN = H (inner) + 125 mm.
Ejemplo = 2.200 mm. (B) + 125 mm. = 2.325 mm.

LONGITUD DE LONA = L (interior) - 400 mm.
Ejemplo = 5.000 mm. (A) - 400 mm. = 4.600 mm.

ALTURA DE LONA = H (interior) + 125 mm.
Ejemplo = 2.200 mm. (B) + 125 mm. = 2.325 mm.m.



Guardabarro, Soportes y Calzos

Mudguards, Wheel Supports and Wedges

Garde-Boue, Support Roue et Cale

Kotflügel, Radhalter und Radkeile

Guardalamas, Suportes de Roda e Calzos



Guardabarro Plástico

Plastic Mudguard

Garde-Boue Plastique

Kotflügel Plastik

Guardalamas Plástico

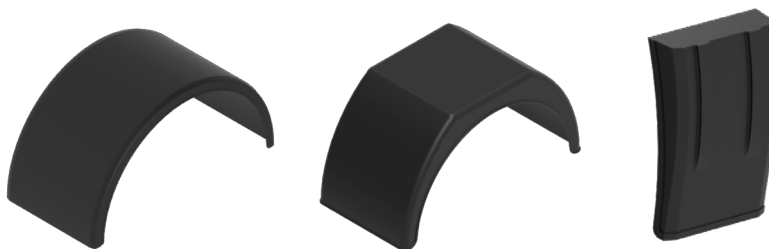

pag. 56-62

Guardabarro Metal

Metal Mudguard

Garde-Boue Metal

Metallkotflügel

Guarda Lamas Metal



pag. 63-65

Faldillas

Mudflaps

Jeu de Bavettes

Schmutzfänger

Palas

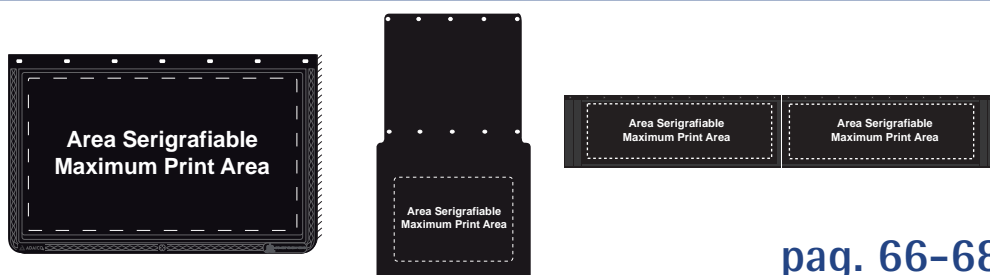

pag. 66-68

Soportes y Bridas

Supports and Clamps

Supports et Fixations

Halter und Binder

Suportes e Braçadeiras



pag. 69-76

Soportes de Ruedas

Wheel Supports

Supports De Roue

Radhalter

Suporte de Rodas

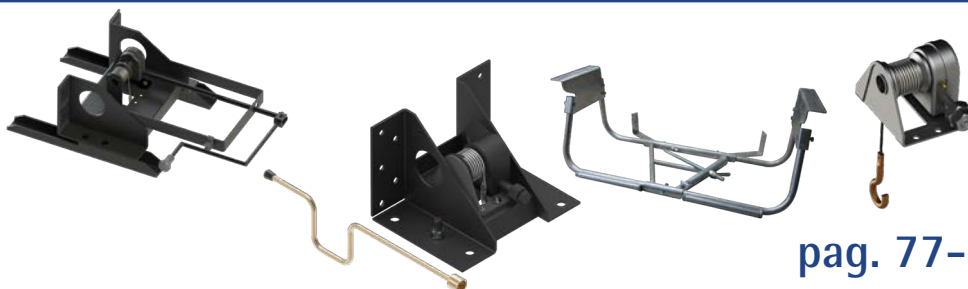

pag. 77-79

Calzos

Wedges

Cale

Radkeile

Calzos

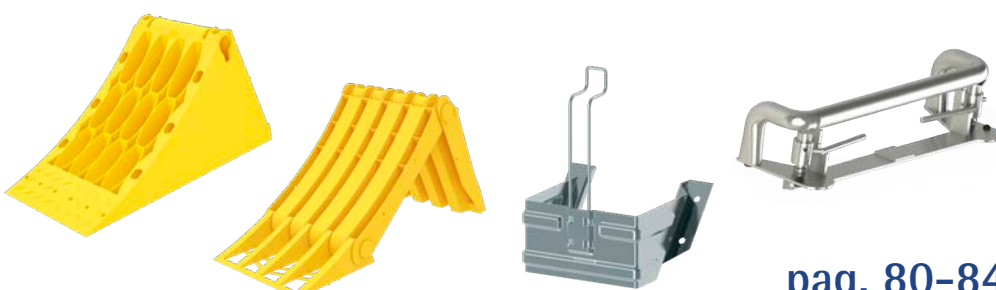

pag. 80-84



PARLOK Round Mudguard PE-HD
 PARLOK Runder Kotflügel PE-HD
 Guardabarros Redondo PARLOK PE-HD

Ref	Kg	Mat	A	B	C	D	E	Lot
0101048	1.1		240	840	1300	420	410	1
0101039	2.3		405	1160	1800	580	580	1
0101047 NEW	2.5		405	1266	1900	635	595	1
0101046	2		415	840	1420	450	460	1
0101040	2.6		430	1300	1900	650	580	2
0101042	2.7		430	1300	2175	690	720	2
0101045	1.9		450	840	1300	420	410	2
0101038	3.5		455	1370	2290	730	755	2
0101043	2.9		480	1160	1800	580	580	2
0101034	2.5		500	1000	1600	500	500	1
0101032 NEW	3.09		550	1000	1500	500	465	1
0101033	2.6		500	1100	1700	550	530	1
0190071 NEW	3.1		500	1370	2140	685	670	1
0101030	3.1		550	1100	1700	550	530	1
0101021	3.5		595	1100	1700	550	530	1
0101025	3.7		600	1160	1850	580	595	2
0101022 NEW	3.8		610	1280	1930	640	610	1
0101024	3.5		630	1060	1630	530	515	1
0101026	3.5		630	1150	1650	580	495	1
0101027 NEW	3.9		650	1160	1800	580	580	1
0101020	4.4		650	1260	1900	630	590	2
0101013	5		670	1340	2090	670	660	1
0101007	4.3		680	1160	1800	580	580	1
0101010	4.9		680	1260	1900	630	590	2
0101005	5.5		680	1380	2175	690	690	1
0101003	5.4		720	1260	1900	630	590	1

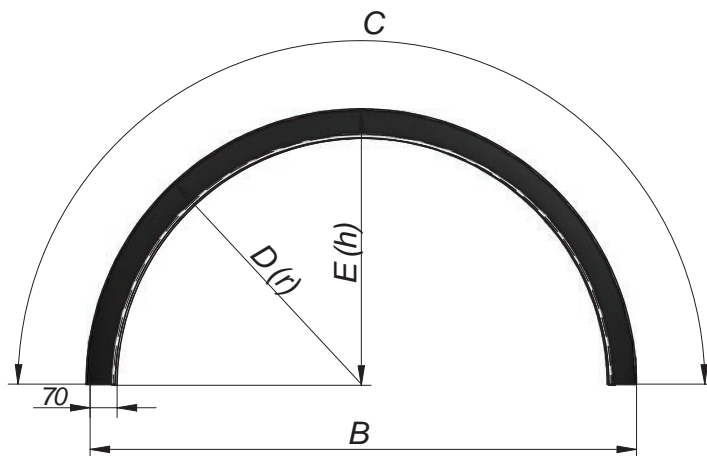



ADAICO Round Mudguard PP
 ADAICO Runder Kotflügel PP
 Guardabarros Redondo PP ADAICO

Ref	Kg	Mat	A	B	C	D	E	F	Lot
0101358	4.3	PP	430	1300	1900	650	580	75	1
0101361	4	PP	430	1300	2125	650	690	75	1
0101348	4.1	PP	670	1340	2125	670	680	75	1

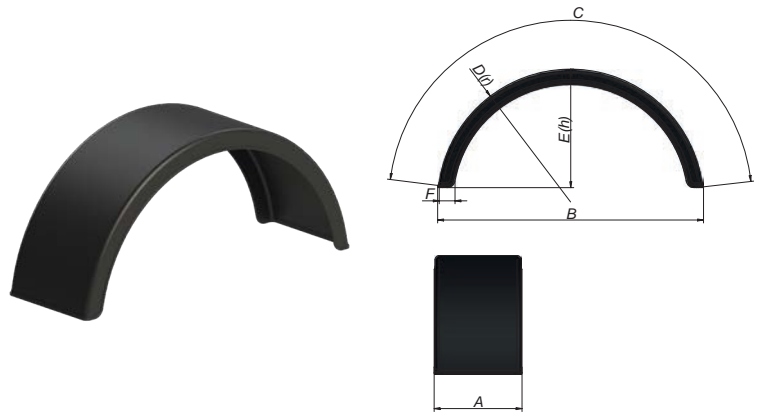

PARLOK Round Mudguard with Antispray Homologated Mudflap
 PARLOK Runder Kotflügel Antispray-Schmutzfänger Anerkannt
 Guardabarros PARLOK Homologado c/Faldilla Antispray

Ref	Kg	Mat	A	B	C	D	E	F	Emark	Lot
0103010	3.5	PE	405	1160	2100	580	890	300	E ₁	1
0103012	3.5	PE	405	1260	2300	635	1040	400	E ₁	1
0103014	4.1	PE	430	1290	2300	650	1050	400	E ₁	1
0103016	4.4	PE	480	1160	2100	580	890	300	E ₁	1
0103020	4.2	PE	500	1000	1900	500	800	300	E ₁	1
0103022	5.2	PE	550	1000	1800	500	800	300	E ₁	1
0103024	5.1	PE	550	1000	2000	500	800	300	E ₁	1
0103026	5.2	PE	595	1000	1870	500	800	300	E ₁	1
0103028	5.4	PE	595	1100	2000	595	850	300	E ₁	1
0103030	5.6	PE	630	1160	2050	580	980	400	E ₁	1
0103032	6.9	PE	650	1260	2575	690	1130	400	E ₁	1
0103034	7.3	PE	670	1320	2490	670	1070	400	E ₁	1
0103036	6.4	PE	680	1160	2050	580	980	400	E ₁	1
0103038	7	PE	680	1260	2300	630	1030	400	E ₁	1
0103040	7.5	PE	720	1260	2300	630	1030	400	E ₁	1

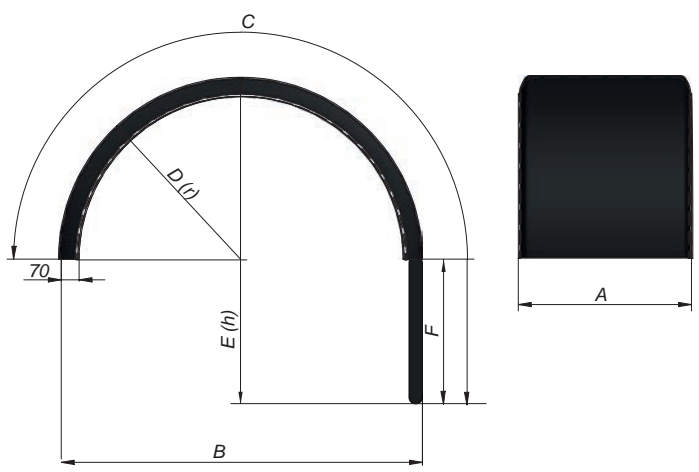

PE-HD | Usage Temperature: -50°C to +80°C | Chemical and Impact Resistance | Light | Easy to install | Integrated spray-suppression | Attractive design
 PE-HD | temperatura de uso: -50°C a +80°C | resistencia química y al impacto | Ligero | Fácil instalación | spray-suppression Integrada | Diseño
 Regulation (EU) 2021/535

PARLOK Round Mudguard PE-HD BLACKLINE
 PARLOK Runder Kotflügel PE-HD BLACKLINE
 Guardabarros Redondo PE-HD PARLOCK BLACKLINE

Ref	Kg	Mat	A	B	C	D	E	F	Lot
0101052	1.3	PE	240	840	1300	420	690	410	1
0101053	1.6	PE	270	960	1500	480	680	480	1
0101054	2.4	PE	320	1075	1600	540	580	490	1

NEW

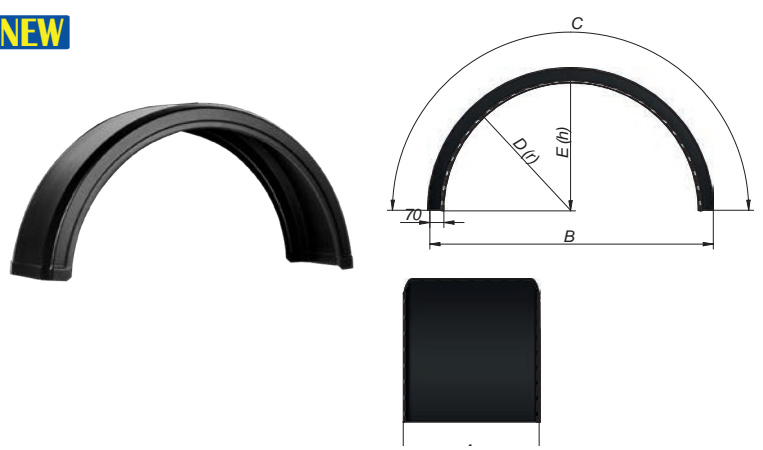

MUDGUARDS AND WEDGES / KOTFLÜGEL UND RADKEILE / GUARDABARROS, SOPORTES, CALZOS



MUDGUARD PLASTIC / KOTFLÜGEL KUNSTSTOFF / GUARDABARROS PLÁSTICO

MUDGUARDS AND WEDGES / KOTFLÜGEL UND RADKEILE / GUARDABARROS, SOPORTES, CALZOS

PARLOK Round Mudguard 3 Pieces, with Clamps
PARLOK Rundes Kotflügel 3 Stück, mit Halterung
Guardabarros Redondo PARLOK 3 Piezas, con bridas

NEW

Ref	Kg	Mat	Lot
0101081	7.58	PE	1

Clamps included | HD-PE
Bridas incluidas | HD-PE

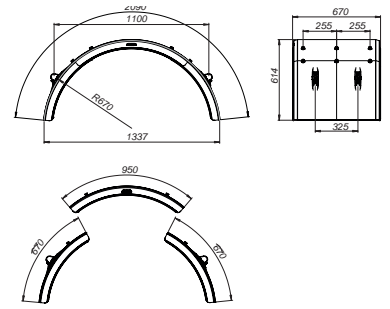

Steering Axle, PARLOK Round Mudguard (F150) PE-HD
PARLOK Runder Kotflügel für Steuerungsachse (F150) PE-HD
Guardabarros Redondo PARLOK, Eje dirección (F150) PE-HD

NEW

Ref	Kg	Mat	A	B	C	D	E	F	Lot
0190002	2.7	PE	430	1450	2050	650	580	150	1
0190005	3.1	PE	480	1310	1950	580	580	150	1
0190072	5.57	PE	670	1490	2300	670	670	150	1

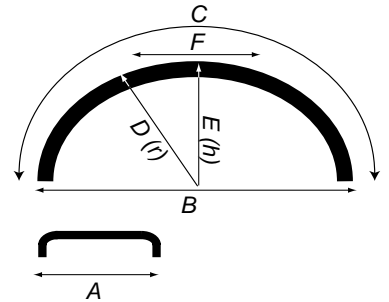

Round Mudguard PE 280x1400x900
Runder Kotflügel PE 280x1400x900
Guardabarros Redondo PE 280x1400x900

Ref	Kg	Mat	Lot
0101366	1.3	PE	1

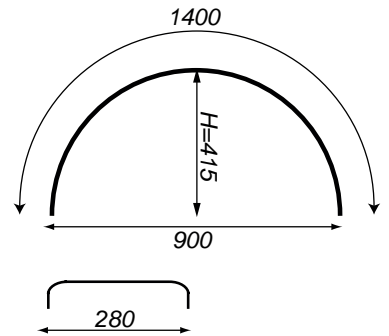

ADAICO Flat Mudguard, PP
ADAICO Kotflügel Kunststoff gerader Rücken, PP
Guardabarros Redondo-Plano ADAICO PP

Ref	Kg	Mat	A	B	C	D	E	F	Lot
0101385	3.4	PP	450	880	1480	400	460	400	2
0101391	4	PP	510	1000	1770	510	550	430	2

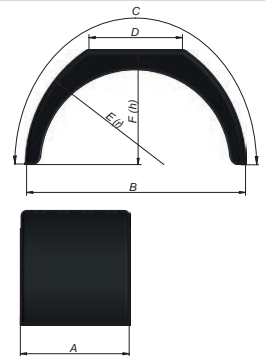

PARLOK Round-Flat Mudguard PE-HD
PARLOK Kotflügel gerader Rücken PE-HD
Guardabarros Redondo-Plano PARLOK PE-HD

Ref	Kg	Mat	A	B	C	D	E	F	Lot
0101017	1.6	PE	260	840	1300	400	360	440	1
0101105	5	PE	550	1150	1880	650	510	570	2

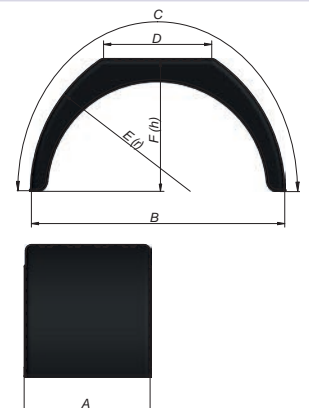



MUDGUARDS AND WEDGES / KOTFLÜGEL UND RADKEILE / GUARDABARROS, SOPORTES, CALZOS

PARLOK Mudguard, Industrial-Agricultural Vehicle
Mittleres Kotflügel PARLOK, Industrie-Landwirtschaftsfahrzeug
Guardabarros PARLOK Vehículo Industrial-Agrícola

NEW

Ref	Kg	Mat	A	B	C	D	Lot
0101120	1.4	PE	380	745	810	580	1
0101121	1.9	PE	405	935	1050	635	1
0101123	2.3	PE	455	1050	1200	685	1
0101127	4.5	PE	500	1370	2140	685	1
0101128	1.9	PE	500	785	900	500	1
0101129	2.2	PE	550	835	950	550	1
0101130	2.4	PE	600	880	1000	580	1
0101132	2.9	PE	650	965	1100	630	1
0101133	3.4	PE	670	1075	1250	670	1
0101135	3.1	PE	720	965	1100	630	1

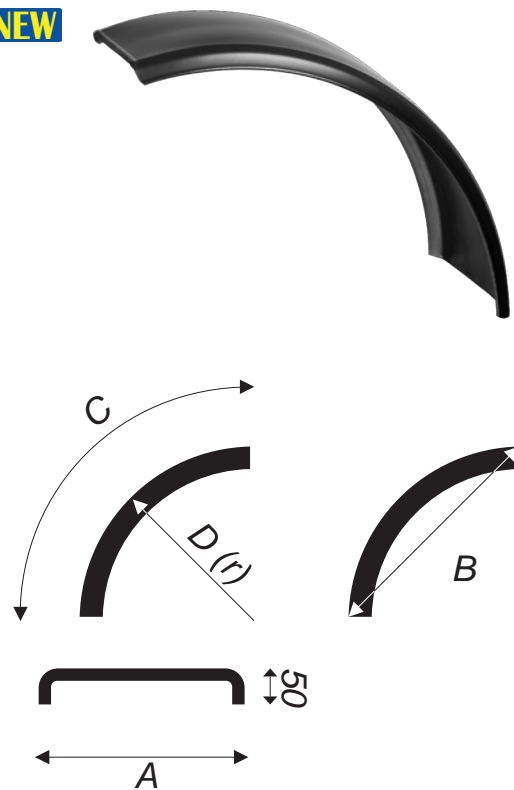

PARLOK Mudguard, Industrial-Agricultural Vehicle
Mittleres Kotflügel PARLOK, Industrie-Landwirtschaftsfahrzeug
Guardabarros PARLOK Vehículo Industrial-Agrícola

NEW

Ref	Kg	Mat	A	B	C	D	Lot
0101122	2.2	PE	405	1100	1250	720	1
0101124	2.7	PE	455	1205	1400	750	1
0101125	3	PE	500	1260	1450	800	1
0101126	3.4	PE	500	1345	1600	800	1
0101131	5.2	PE	610	1535	2100	790	1
0101134	5.2	PE	670	1625	1950	950	1
0101136	5.2	PE	720	1480	1800	850	1

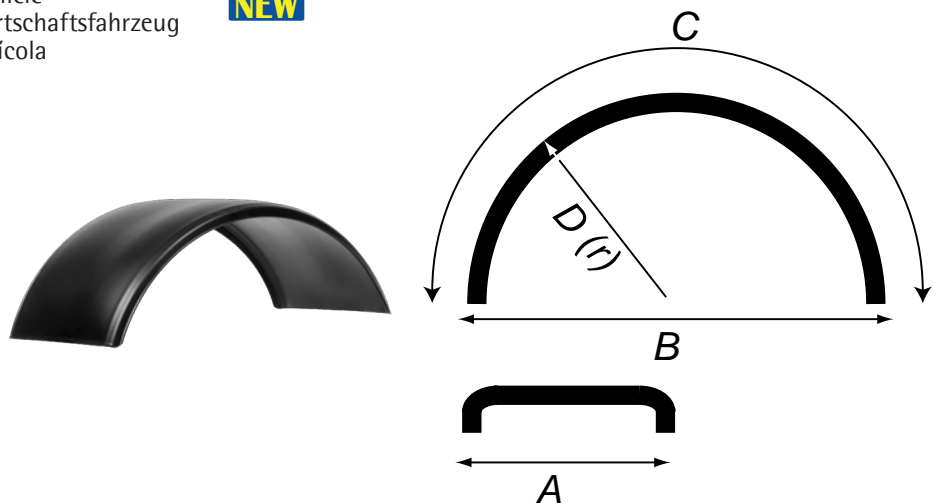



MUDGUARD PLASTIC / KOTFLÜGEL KUNSTSTOFF / GUARDABARROS PLÁSTICO

MUDGUARDS AND WEDGES / KOTFLÜGEL UND RADKEILE / GUARDABARROS, SOPORTES, CALZOS

ADAICO Medium-Flat Mudguard
ADAICO Kurz-Kotflügel
Guardabarros Medio-Plano ADAICO

Ref	Kg	Mat	Lot
0101393	1.9		1

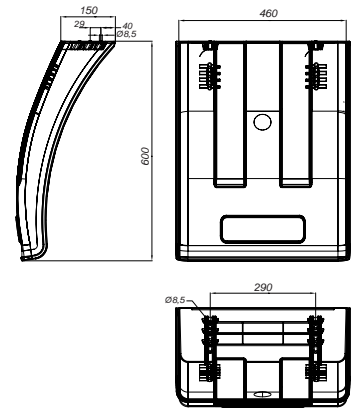

ADAICO Medium Mudguard PP-HD
ADAICO Viertel-Kotflügel PP-HD
Guardabarros Medio ADAICO PP-HD

Ref	Kg	Mat	Lot
0101224	1.05		1

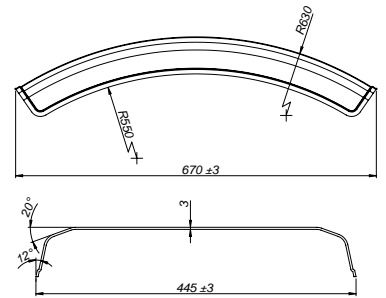

PARLOK Medium Mudguard PE-HD
PARLOK Viertel-Kotflügel PE-HD
Guardabarros Medio PARLOK PE-HD

Ref	Kg	Mat	A	B	C	Lot
0101220	0.9		430	620	650	2
0101216	1.1		550	610	650	1
0101214	1.3		600	620	650	1
0101205	1.5		650	620	650	2
0101202	1.7		670	630	700	1

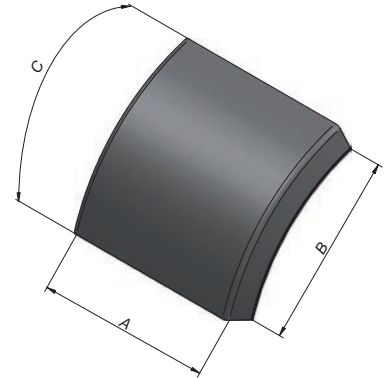

Homologated Antispray Medium-Flat Mudguard 450x730
Antispray Kurz-Kotflügel 450x730 Annerkant
Guardabarros Medio-Plano 450x730 Homologado Antispray

Ref	Kg	Mat	Lot
0101398	1.96		2

Antispray
91/226/EEC

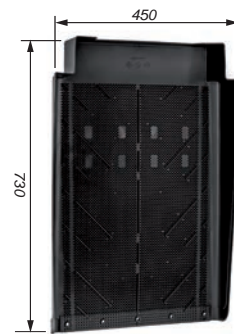

PARLOK Medium-Flat Mudguard PE-HD
PARLOK Kurz-Kotflügel PE-HD
Guardabarros Medio-Plano PARLOK PE-HD

Ref	Kg	Mat	A	B	C	Lot
0101230	1.9		500	600	190	2
0101232	1.2		460	400	110	1



0101232



0101230

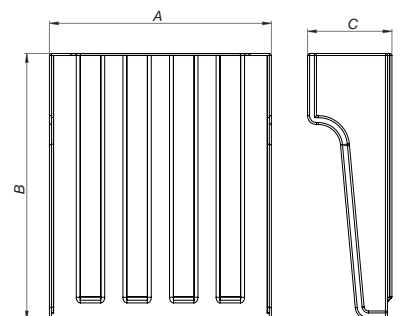

PARLOK Medium Mudguard
 PARLOK Dreiachs-Kotflügel
 Guardabarros Medio Tándem/Trident PARLOK

Ref	Kg	Mat	A	Article	Lot
0101252	4.9		650	Tandem	1
0101262	3.4		430		2

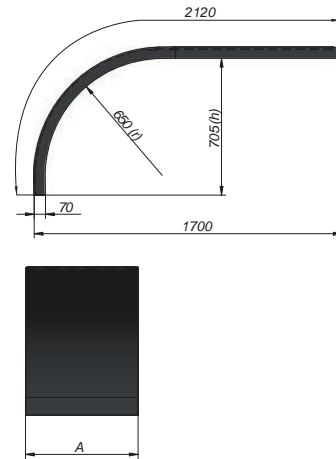

PARLOK Flat Mudguard
 PARLOK Dreiachs-Kotflügel
 Guardabarros Plano PARLOK

Ref	Kg	Mat	A	Lot
0101266	1.7		430	1

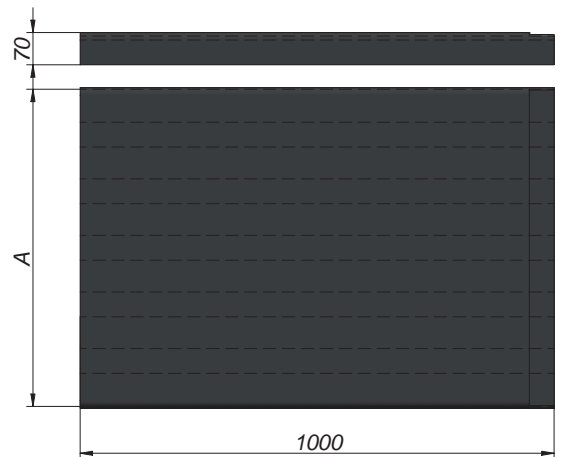

Side Mudguard Antispray L=3700 with Alu Profile
 Antispray Seitenschürze L=3700 mit Aluminium Profil
 Banda Lateral Antispray L=3700 c/Aluminio

Ref	Kg	Mat	A	B	Emark	Lot
0101282	5.2		100	151		1
0101284	3.29		50	101		1

recyclable HDPE | Aluminium profile |
 Reduces water spray and allows better visualization during the trip.
 HDPE reciclable | Perfil de aluminio |
 Reduce la pulverización del agua y permite mejor visualización durante el viaje.
 91/226/CEE

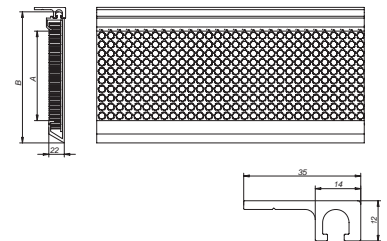

Tandem Mudguard 650x3385x2670
 Doppelachs-Kotflügel 650x3385x2670
 Guardabarros Tándem 650x3385x2670

Ref	Kg	Mat	Lot
0101440	11.9		1

Molded in one piece | PE UV stabilized, chemical resistant, 100% recyclable
 Moldeado en una sola pieza | PE estabilizado a los rayos UV, resistente a químicos, 100% reciclable

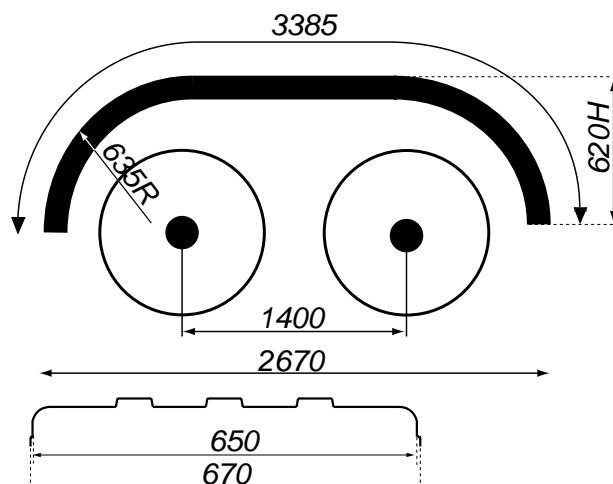

MUDGUARDS AND WEDGES / KOTFLÜGEL UND RADKEILE / GUARDABARROS, SOPORTES, CALZOS



METAL MUDGUARD / METALLKOTFLÜGEL / GUARDABARROS METAL

MUDGUARDS AND WEDGES / KOTFLÜGEL UND RADKEILE / GUARDABARROS, SOPORTES, CALZOS

Aluminium Round Mudguard, checkerplate 2,5/4mm
Runder Kotflügel Aluminium Raupenblech Quintett 2,5/4mm.
Guardabarros Redondo Aluminio 2,5/4mm. tipo damero

NEW

Ref	Kg	Mat	Thickn. Espesor	Lot
0102096	15		2,5-4	1

Aluminium 5 Bar checkerplate 2,5/4 mm.
Aluminio estriado 2,5/4 mm. tipo damero 5 palillos

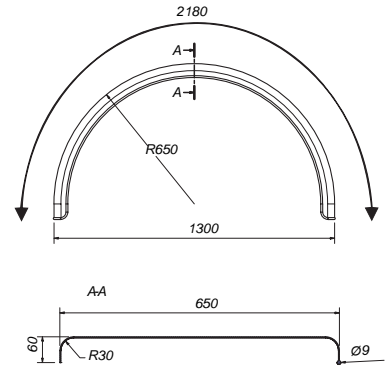
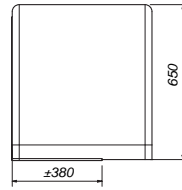

Aluminium Tandem Mudguard, checkerplate 2,5/4mm
Tandem Kotflügel Aluminium Raupenblech Quintett 2,5/4mm.
Guardabarros Tandem Aluminio 2,5/4mm. tipo damero

NEW

Ref	Kg	Mat	Thickn. Espesor	Lot
0102094	25		2,5-4	1

Aluminium 5 Bar checkerplate 2,5/4 mm.
Aluminio estriado 2,5/4 mm. tipo damero 5 palillos

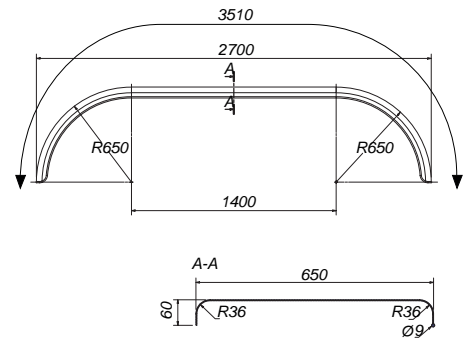
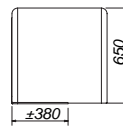

Alu Tandem Mudguard Left-Right, checkerplate 2,5/4 mm
Tandem Kotflügel Links-Rechts Alu Raupenblech Quintett 2,5/4 mm.
Guardabarros Tandem Izdo-Dcho Alu 2,5/4 mm. tipo damero

NEW

Ref	Kg	Mat	Pos	Thickn. Espesor	Lot
0102098	20			2,5-4	1
0102099	20			2,5-4	1

Aluminium 5 Bar checkerplate 2,5/4 mm.
Aluminio estriado 2,5/4 mm. tipo damero 5 palillos

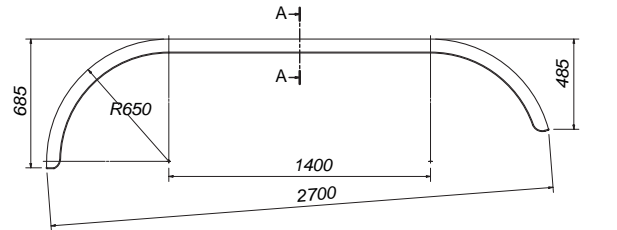

Aluminium Profile Mudguard L=6m.
Alu Profil für Tandem Kotflügel L=6m.
Perfil Aluminio Embellecedor Guardabarros Tandem L=6m.

NEW

Ref	Kg	Mat	A	Thickn. Espesor	Lot
1402564	4.98		6 m.	1.5	1

Profile to adhere the reflective tape
Embellecedor para adherir la cinta reflectante

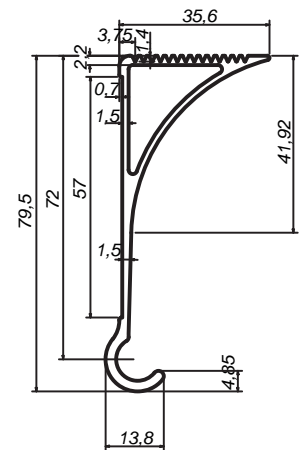



Steel-Rubber Round Mudguard
Runder Kotflügel Edelstahl mit Gummirand
Guardabarros Redondo Chapa-Goma

Ref	Kg	Mat	Sup/Finish Acabado	A	B	C	Lot
0102054	7.2	INOX		450	1300	1900	1
0102056	8	INOX		450	1340	2100	1
0102156	6.5	STEEL	Zn	450	1340	2000	1
0102138	8.8	STEEL	Zn	450	1500	2355	1
0102120	7.29	STEEL	Zn	550	1100	1700	1
0102100	10.4	STEEL	Zn	650	1340	2100	1
0102058	11.5	INOX		675	1340	2100	1

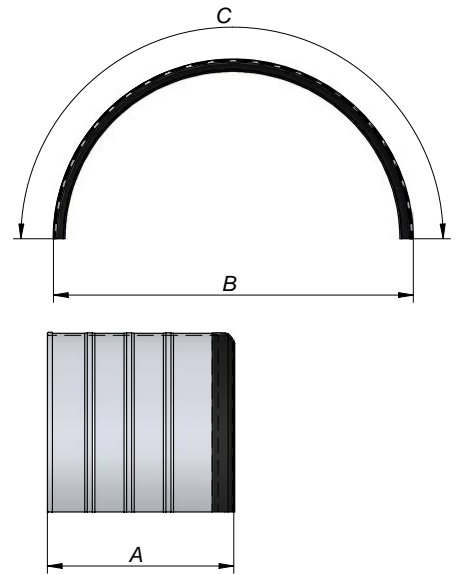

Flat Mudguard (double axle / triple axle)
Doppelachs-Kotflügel Stahl Galv. Verzinkt
Guardabarros Tándem/Trident Chapa-Goma

Ref	Kg	Mat	Sup/Finish Acabado	A	B	C	Thickn. Espesor	Article	Lot
0102020	17.6	STEEL	Zn	650	2740	3550	0.8		1
0102025	20	STEEL	Zn	500	3950	4750	0.8		1

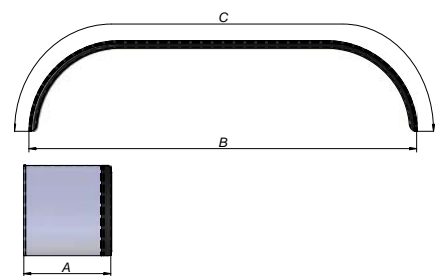

Tandem Mudguard Galvanized Steel
Doppelachs-Kotflügel Stahl Feuerverzinkt
Guardabarros Tándem Chapa Galvanizada

Ref	Kg	Mat	Sup/Finish Acabado	Lot
0102016	17	STEEL	Galv	1

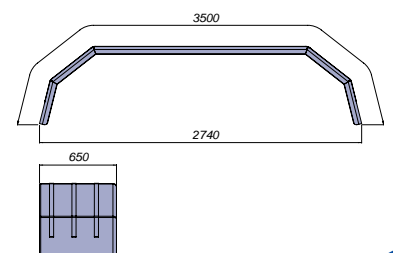



List of Mudguards-Tyre
Kotflügel-Reifen Aufstellung
Tabla de aplicaciones Guardabarros-Ruedas

Diam.	Tyre	Ref.
13"	13/70 R 22,5	0103012
	13/80 R 20	0103012
14"	14/80 R 20	0103012
	185-205/75R14	0101385
	185-205R14	0101385
15"	15 R 22,5	0103012
	185-195R15	0101385
	185-205/70R15	0101385
	8.25R15	0101030 / 0102120
16"	175-185R16	0101342
	185-195/75R16	0101385
	195-215R16	0101022
	225/100R16	0102120
	255/100R16	0101030 / 0101105
	325/85R16	0101039
	7.00R16	0101045
	8.25-9,00R16	0102120
	8.25R16	0101030 / 0101105
	9.00R16	0101030 / 0101105
17"	8.25R17	0101030 / 0101105
17,5"	205-215/75R17,5	0103020
	225/75R17,5	0101032
	225-245/75R17,5	0101105 / 0102120
	235/75R17,5	0101105 / 0101032
	245/70R17,5	0101105
	355/45R17,5	0101039
	8.00R17,5	0101045
	8.25R17,5	0102120
	8-8.5R17,5	0103020
	8-9R17,5	0103020
	9.5R17,5	0101030 / 0101105
	10R17,5	0102120 / 0101105

Diam.	Tyre	Ref.
19,5"	245/65R19,5	0101030
	245/70R19,5	0101105
	255/60R 19,5	0103026
	305/70R19,5	0101039
	315/70R19,5	0101039
	385/55R19,5	0101039
	385/65R19,5	0101039
	425/55R19,5	0101043
	435/50R19,5	0101043
	445/45R19,5	0101043
	7R19,5	0101045
	8R19,5	0103020
	9R19,5	0101105 / 0103020
	9.5R19,5	0101030 / 0101105 / 0102120
	10R19,5	0101025 / 0101105
	12R19,5	0101039
	15R19,5	0101039
	16.5R19,5	0101040 / 0103014 / 0101340 / 0101342 / 0102025 / 0102156 / 0102045 / 0102056 / 0102054
	18R19,5	0190071
	19.5R19,5	0190071
20"	225/90R20	0101030 / 0102120
	335/80 R20	0103012 / 0101047
	355-365/80R20	0101340 / 0101361 / 0102025 / 0102156 / 0102045 / 0102056 / 0102054 /
	365/80R20	0101040 / 0103014 / 0101042 / 0101262 / 0103012
	475/80R20	0190071
	475/60R20	0190071
	7.00-8.25R20	0101105 / 0102120
	7.50R20	0101043 / 0101105 /
	7-7.50R20	0101105
	8.25R20	0101025 / 0101105
	9.00R20	0101025 / 0101022
	10.00R20	0103012 / 0101022 / 0101047
	11R20	0101205 / 0101252 / 0103032 / 0103012 / 0101047
	11.00R20	0101020
	12.00R20	0101013 / 0101040 / 0103014 / 0101042 / 0101262

Diam.	Tyre	Ref
20"	12/80R20	0101348 / 0102020 / 0102100 / 0102040 / 0102025 / / 0101005 / 0101010 / 0103012
	12-13,00R20	0101361 / 0101358 / 0102025 / 0102156 / 0102045 / 0102056 / 0102054 / 0103012
	12R20	0101348 / 0102020 / 0102100 / 0102040 / 0102050
	13-14.75/80R20	0101361
	14/80R20	0103012 / 0101047
	14.75/80R20	0101040 / 0103014
	14.75-15.5/80R20	0101042 / 0101358 / 0102025 / 0102156 / 0102045 / 0102056 / 0102054 / 0101262
	15.5/80R20	0101040 / 0103014
	E-G20 PILOTE	0101358 / 0102025 / 0102156 / 0102045 / 0102056 / 0102054
22,5"	275/80R22,5	0101020 / 0101205 / 0101252 / 0103032 / 0103012 / 0101047
	295/70R22,5	0101020 / 0101205 / 0101252 / 0103032 / 0103012 / 0101047
	295/75R22,5	0101010 / 0101348 / 0102020 / 0102100 / 0102040 / 0102050 / 0103012
	295/80R22,5	0101010 / 0103012 / 0101047
	295-315/75R22,5	0101005
	295-315/80R22,5	0101361 / 0101358 / 0102025 / 0102156 / 0102045 / 0102056 / 0102054 / 0101005
	305/60R22,5	0101039
	305/70R22,5	0101010 / 0103012
	305-315/70R22,5	0101005 / 0101358 / 0102025 / 0102156 / 0102045 / 0102056 / 0102054 / 0101361
	315/60R22,5	0101039
	315/70R22,5	0101010 / 0103012 / 0101047
	315/75R22,5	0101003 / 0103012
	315/80R22,5	0101003 / 0103012 / 0101047
	335/80R22,5	0103012
	345/75R22,5	0103012 / 0101047
	350/75R22,5	0101356 / 0101358 / 0102025 / 0102156 / 0102045 / 0102056 / 0102054 / 0103012 / 0101047
	355/50R22,5	0101039
	365/65R22,5	0101042
	365/65R22,5	0101262
	365/70R22,5	0103012 / 0101047
	365/85R22,5	0103012
	370/70R22,5	0103012
	375/90R22,5	0101038
	385/55R22,5	0101039

Diam.	Tyre	Ref	
22,5"	385/65R22,5	0101040 / 0103014 / 0101358 / 0101361 / 0102025 / 0102156 / 0102045 / 0102056 / 0102054	
	385/95R22,5	0101038	
	415/45R22,5	0101043	
	435/45R22,5	0101043	
	445/40R22,5	0101043	
	445/50R22,5	0101043	
	445/75R22,5	0190071	
	455/40R22,5	0101043	
	455/45R22,5	0101043	
	455/55R22,5	0101043	
	8-9R22,5	0102120	
	8R22,5	0101105 / 0101043	
	9/70R22,5	0101105	
	9R22,5	0101025	
	10/70R22,5	0101030 / 0101105 / 0102120	
	11R22,5	0103012 / 0101022	
	12R22,5	0103012	
	11/70R22,5	0101025	
	12/70R22,5	0101010 / 0101005 / 0103012	
	12/80R22,5	0101010 / 0101005 / 0103012	
	12-13/70R22,5	0101358 / 0101361 / 0102025 / 0102156 / 0102045 / 0102056 / 0102054 / 0103012	
	12-13R22,5	0101005	
	12R22,5	0101010 / 0101348 / 0102020 / 0102100 / 0102040 / 0102050	
	13R22,5	0101040 / 0101003 / 0103014 / 0101042 / 0101262 / 0103040	
	15R22,5	0103012	
	18R22,5	0190071	
	E22,5 PILOTE	0101358 / 0101361 / 0102025 / 0102156 / 0102045 / 0102056 / 0102054	
	24"	11.00R24	0101013 / 0101040 / 0103014
		12.00R24	0101013
24,5"	295/80 R 24,5	0103012	
	305/75 R 24,5	0103012	
	315/75 R 24,5	0103012	
	11.00R24,5	0101348 / 0102020 / 0102100 / 0102040 / 0102050	
	285/75R24,5	0101020	
	295/80R24,5	0101013 / 0101348 / 0102020 / 0102100 / 0102040 / 0102050 / 0103012	
	305/75R24,5	0101010 / 0103012	
	315/75R24,5	0101003 / 0101010 / 0103012 / 0103040	

















ANTISPRAY System



- ✓ **HOMOLOGATION / HOMOLOGACIÓN:**
European Directive 2021/535 UE 
- ✓ **MATERIAL / MATERIAL:**
 - Black PVC Shore Hardness = 85
 - PVC Negro Dureza Shore = 85
- ✓ **LIFE CYCLE / VIDA ÚTIL**
 - Minimum **10 years** with a proper installation
 - Mínimo **10 años** con una correcta instalación
- ✓ **SERIGRAPH/ SERIGRAFÍA**
 - Excellent **Publicity** for your brand
 - Excelente **Publicidad** de su marca
- ✓ **RESISTANCE/ RESISTENCIA:**
 - High and low **Temperatures**
 - Altas y bajas **Temperaturas**
- ✓ **ANTISPRAY / ANTISPRAY:**
 - **Absorption** of 76,4% of water projections
 - **Absorción** del 76,4% de Proyección de agua



Homologated Mudflap PVC with anti-spray
Antispray-Schmutzfänger PVC
Faldilla PVC Homologada Antispray

Ref	Kg	Mat	A	B	C	Thickn. Espesor	Emark	Article	Lot
6801540	0.64		260	300	200x200	14		3	2
6801542	0.74		350	300	280x210	14		4	2
6801544	0.97		400	300	330x210	14		5	2
6801546	1.25		450	350	380x260	14		5	2
6801548	1.64		530	370	450x280	14		6	2
6801550	1.99		620	400	540x310	14		7	2
6801552	2.15		650	400	580x310	14		7	2

Anti-Spray System | Temperature: -35°-40° | Easy Installation | Logo option
Sistema Anti-Spray | Temperatura: -35°-40° | Fácil Instalación | Personalizable con Logo
Regulation (EU) 2021/535

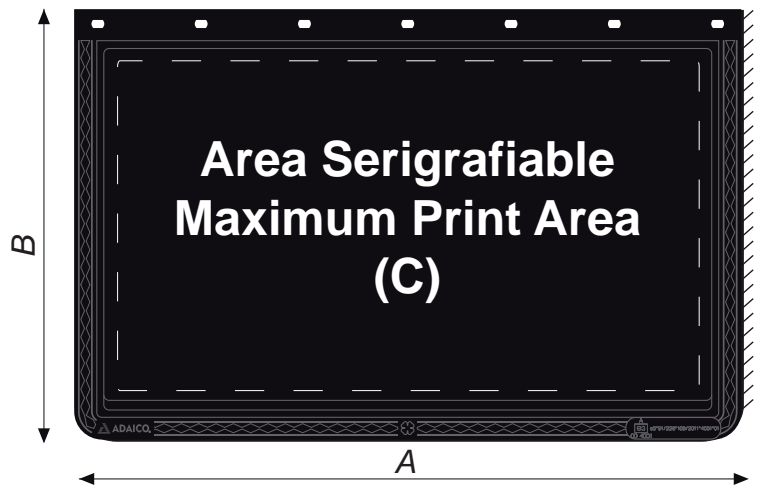

4 Plates Set Mudflap
Schmutzfänger-Befestigung 4er-Set
Kit 4 Pletinas Sujeción Faldillas

Ref	Kg	Mat	Sup/Finish Acabado	A	B	C	Thickn. Espesor	Lot
6801680	0.16	STEEL		260	35	3	1	1
6801682	0.22	STEEL		350	32.5	4	1	1
6801684	0.25	STEEL		400	10	5	1	1
6801686	0.3	STEEL		450	35	5	1	1
6801688	0.33	STEEL		530	27	6	1	1
6801690	0.39	STEEL		620	25	7	1	1
6801692	0.41	STEEL		650	40	7	1	1

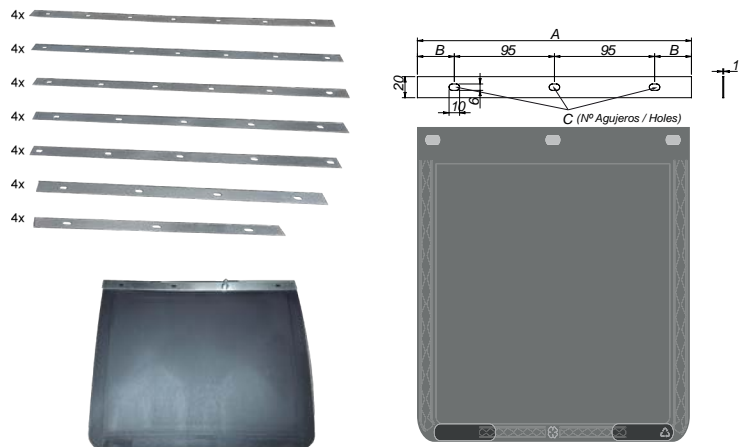

Bolt+Nut+Washer Set Mudflap
Schmutzfänger-Befestigung Schraub-Set
Kit tornillería para Pletinas Faldillas

Ref	Kg	Mat	Sup/Finish Acabado	A	Lot
6801696	0.22	STEEL		24	1
6801698	0.25	STEEL		28	1

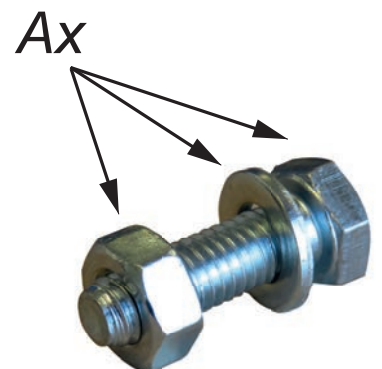

Homologated PVC Mudflap with Anti-spray
Annerkant Antispray-Schmutzfänger PVC
Faldilla Aletas PVC Homologada Antispray

Ref	Kg	Mat	A	B	C	Thickn. Espesor	Emark	Article	Lot
6801562	2.59		400	330	390x300	14		4	2
6801564	3.17		450	400	440x300	14		5	2
6801566	3.57		530	450	510x300	14		5	2
6801568	4.31		620	550	590x300	14		5	2
6801570	4.52		650	600	620x300	14		7	2

Anti-Spray System | Temperature: -35°-40° | Easy Installation | Logo option
Sistema Anti-Spray | Temperatura: -35°-40° | Fácil Instalación | Personalizable con Logo
Regulation (EU) 2021/535

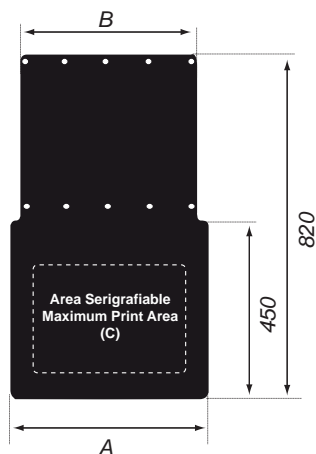

Homologated Straight PVC Mudflap with Anti-spray
Annerkant Gerader Antispray Spritzlappen PVC
Faldilla Recta PVC Homologada Antispray

Ref	Kg	Mat	A	B	Thickn. Espesor	Emark	Article	Lot
6801592	2.56		400	740	14		5	1

Anti-Spray System | Temperature: -35°-40° | Easy Installation | Logo option
Sistema Anti-Spray | Temperatura: -35°-40° | Fácil Instalación | Personalizable con Logo
Regulation (EU) 2021/535

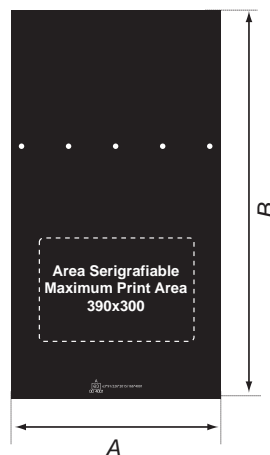

Homologated Tail Mudflap PVC with Anti-spray
Annerkant Antispray-Schmutzfänger PVC
Faldón PVC Homologada Antispray

Ref	Kg	Mat	A	B	Thickn. Espesor	Emark	Article	Lot
6801580	3.1		500	700	14		5	2
6801582	4.2		500	900	14		5	2
6801584	3.9		600	700	14		7	2
6801586	5		600	900	14		7	2
6801588	4.34		700	700	14		7	2
6801590	5.58		700	900	14		7	2

Anti-Spray System | Temperature: -35°-40° | Easy Installation | Logo option
Sistema Anti-Spray | Temperatura: -35°-40° | Fácil Instalación | Personalizable con Logo
Regulation (EU) 2021/535

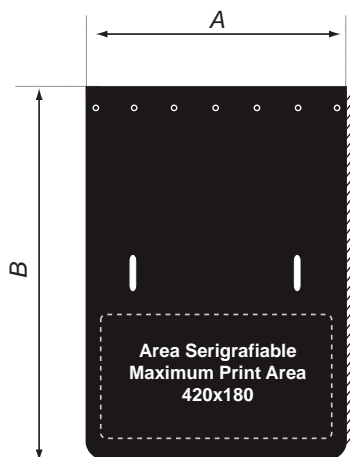

Mudflap PVC
Schmutzfänger PVC
Faldilla PVC

Ref	Kg	Mat	A	B	C	Thickn. Espesor	Article	Lot
6801510	0.28		250	250	230x180	3	3	2
6801512	0.44		350	350	340x280	3	4	2
6801514	0.54		400	300	520x285	3	5	2
6801516	0.73		450	350	440x280	3	5	2
6801518	0.89		530	370	390x225	3	6	2
6801520	1.06		620	400	610x320	3	7	2

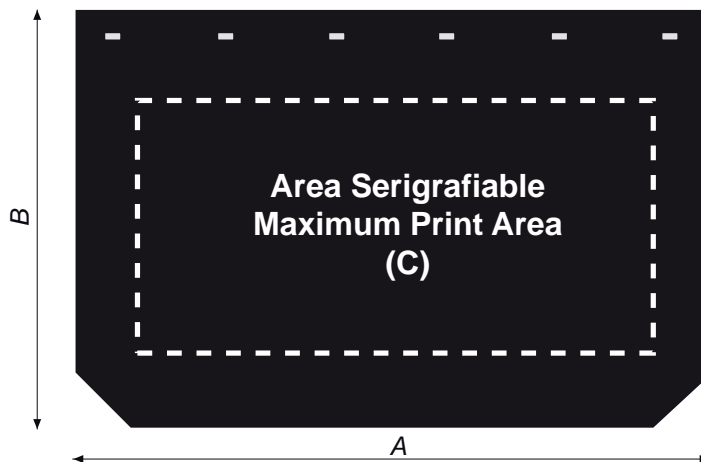

MUDGUARDS AND WEDGES / KOTFLÜGEL UND RADKEILE / GUARDABARRROS, SOPORTES, CALZOS



MUDFLAPS / SCHMUTZFÄNGER / FALDILLAS

MUDGUARDS AND WEDGES / KOTFLÜGEL UND RADKEILE / GUARDABARRROS, SOPORTES, CALZOS

Rear Bumper Mudflap PVC 1200x380
Antispray-Heckschürze PVC 1200x380
Faldón PVC Paragolpes 1200x380

Ref	Kg	Mat	Pos	Thickn. Espesor	Article	Lot
6801602	3.3			5	13	1
6801604	3.3			5	13	1

Temperature: -35°-40° | Easy Installation | Logo option
Temperatura: -35°-40° | Fácil Instalación | Personalizable con Logo

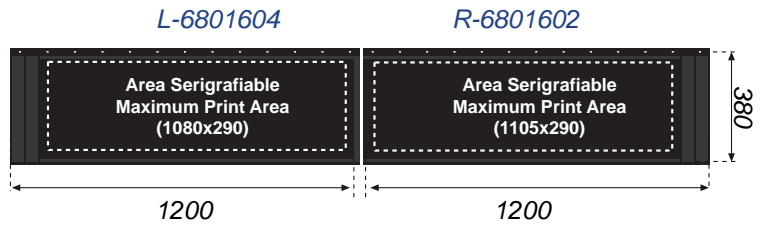

Rear Bumper Mudflap PVC 2400x350
Antispray-Heckschürze PVC 2400x350
Faldón PVC Paragolpes 2400x350

Ref	Kg	Mat	Col	Pos	Thickn. Espesor	Lot
6801606	6.6				4	1
6894003	6.6				4	1
6894004	6.6				4	1
6894007	6.6				4	1

Temperature: -35°-40° | Easy Installation | Logo option | 80/85 Shore
Temperatura: -35°-40° | Fácil Instalación | Personalizable con Logo | 80/85 Shore

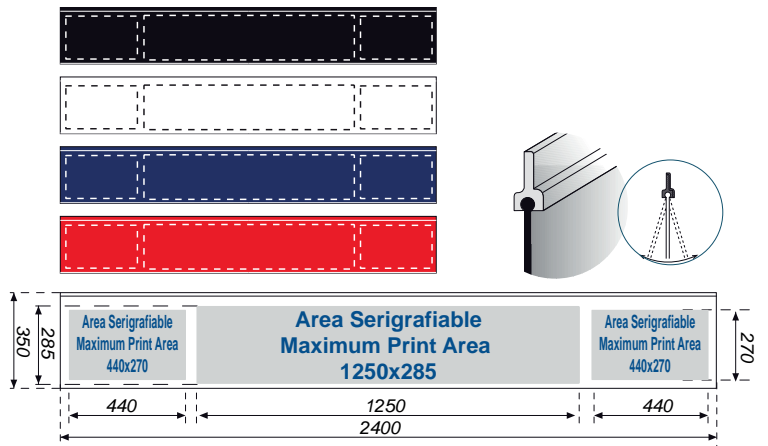

2 Profiles Set For Bumper Mudflap 1200x37 PVC
2er Set Halter für Heckschürze 1200x37 PVC
kit 2 perfiles PVC Sujeción Faldón 1200x37

Ref	Kg	Mat	Lot
6801608	0.71		1

This mounting system prevents the flaps are attached to the chassis;
Bores are made in the PVC profile
Este sistema de montaje evita que los faldones se fijan al chasis;
los taladros se realizan en el perfil de PVC

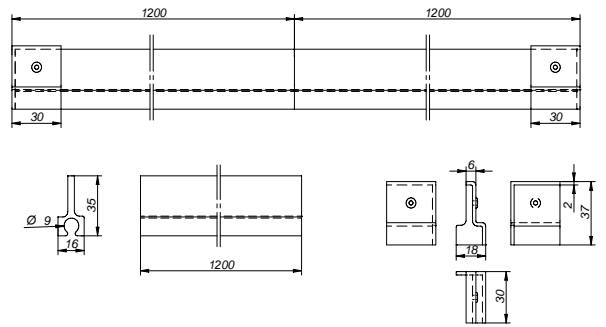
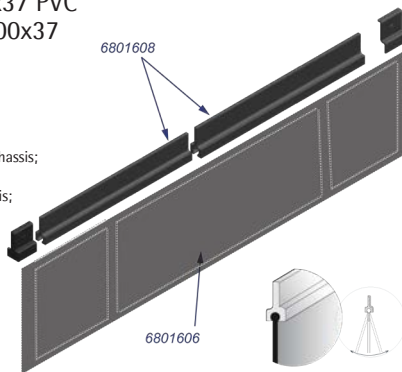

Homologated Antispray Mudflap PE-HD
Antispray-Schmutzfänger PE-HD Annerkant
Faldilla PE-HD Homologada Antispray

Ref	Kg	Mat	A	B	C	D	Emark	Lot
6801310	2.5		620	615	400	820		2
6801315	1.6		400	395	400	820		2

The screws to fix the mudflap are included in the accessory kit
El set de tornillos de fijación se incluye en el kit
UE Directive 2010/19 EU

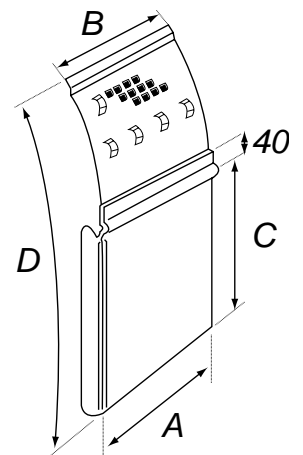

SUPPORTS AND CLAMPS / KOTFLÜGELHALTER UND BEFESTIGUNG / SOPORTES Y BRIDAS



Mudguard Support Ø42 Curved with Bolt
Kotflügel Halterung Ø42 Gekrümmt mit Schrauben
Soporte Guardabarras Ø42 Curvado c/Tornillo

Ref	Kg	Mat	Sup/Finish Acabado	Col	A	Ø	Thickn. Espesor	Metric	Lot
0106015	1.4	STEEL	Zn	Ag	540	42	2	M16	1
0106014	1.6	STEEL	Zn	Ag	665	42	2	M16	1

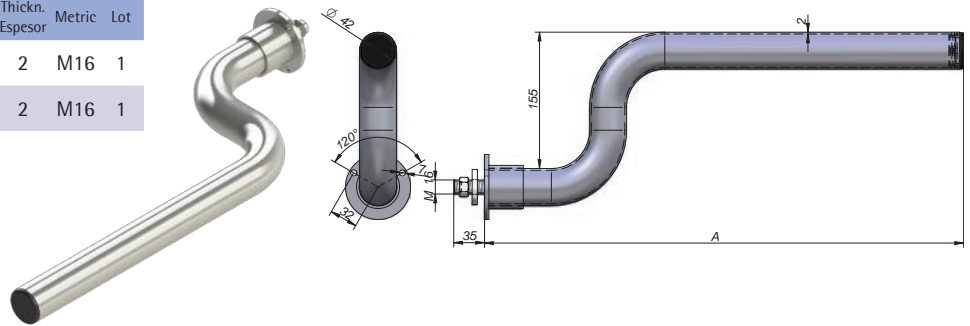

Mudguard Support Ø42 with Bolt
Kotflügel Halterung Ø42 mit Schrauben
Soporte Guardabarras Ø42 c/Tornillo

Ref	Kg	Mat	Sup/Finish Acabado	Col	A	Ø	Thickn. Espesor	Metric	Lot
0106017	1.5	STEEL	Zn	Ag	540	42	2	M16	1
0106016	1.75	STEEL	Zn	Ag	665	42	2	M16	1

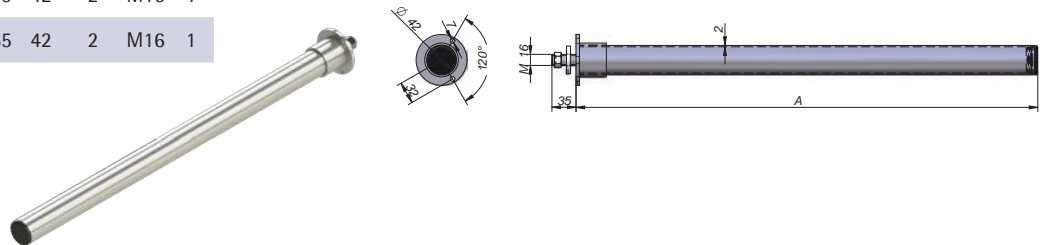

Mudguard Support Curved 750xØ42
Kotflügel-Tragrohr Gekrümmt 750xØ42
Soporte Guardabarras Curvado 750xØ42

Ref	Kg	Mat	Sup/Finish Acabado	Col	Ø	Thickn. Espesor	Lot
0106034	2.65	STEEL	Zn	Ag	42	2	1
0106037	2.38	STEEL	KTL	Black	42	2	1

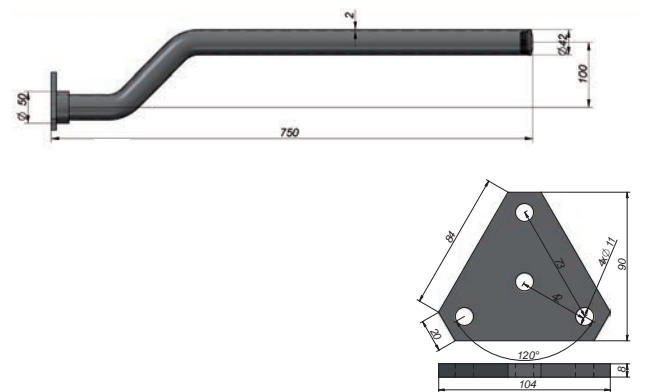

Mudguard Support Ø42 with Triangular Base
Kotflügel-Tragrohr Ø42 mit Dreieckflansch
Soporte Guardabarras Ø42 c/Base Triangular

Ref	Kg	Mat	Sup/Finish Acabado	Col	Ø	Thickn. Espesor	Lot
0106042	2.01	STEEL	Zn	Ag	42	2	2
0106043	2.01	STEEL	KTL	Black	42	2	2

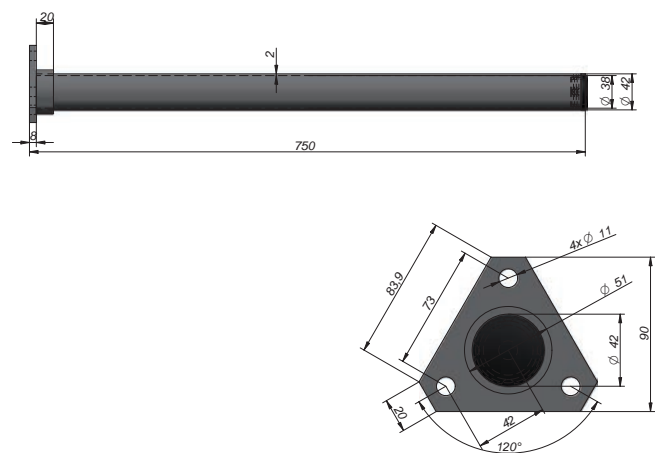

MUDGUARDS AND WEDGES / KOTFLÜGEL UND RADKEILE / GUARDABARRAS, SOPORTES, CALZOS



SUPPORTS AND CLAMPS / KOTFLÜGELHALTER UND BEFESTIGUNG / SOPORTES Y BRIDAS

MUDGUARDS AND WEDGES / KOTFLÜGEL UND RADKEILE / GUARDABARRROS, SOPORTES, CALZOS

Mudguard Support Ø42 Straight Zinc, no Welding
Kotflügel-Tragrohr Ø42 Verzinkt
Soporte Ø42 Recto Cincado, sin Soldaduras

NEW

Ref	Kg	Mat	Sup/Finish Acabado	Col	A	Ø	Thickn. Espesor	Metric	Lot
0106260	1.81	STEEL	Zn	Ag	600	42	2	M16	1
0106275	2.09	STEEL	Zn	Ag	750	42	2	M16	1

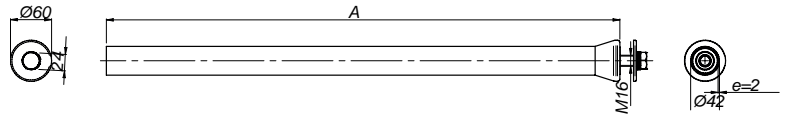

Mudguard Support Ø42 Curved Zinc Plated, no Welding
Kotflügel-Tragrohr Ø42 Gekrümmt Verzinkt
Soporte Ø42 Curvado Cincado, sin Soldaduras

NEW

Ref	Kg	Mat	Sup/Finish Acabado	Col	A	B	Ø	Thickn. Espesor	Metric	Lot
0106258	1.74	STEEL	Zn	Ag	580	305	42	2	M16	1
0106273	2.01	STEEL	Zn	Ag	730	455	42	2	M16	1

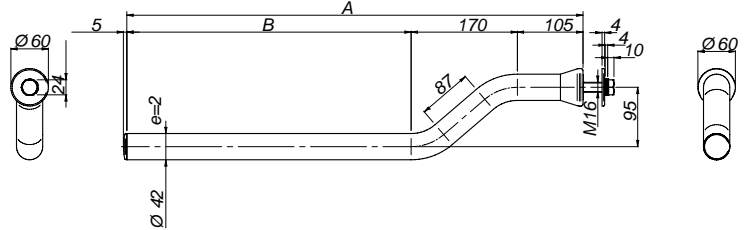

Mudguard Support Ø42 Straight Painted, no Welding
Kotflügel-Tragrohr Ø42 Lackiert
Soporte Ø42 Recto Pintado, sin Soldaduras

NEW

Ref	Kg	Mat	Sup/Finish Acabado	Col	A	Ø	Thickn. Espesor	Metric	Lot
0106360	1.81	STEEL	Paint	Black	600	42	2	M16	1
0106375	2.09	STEEL	Paint	Black	750	42	2	M16	1

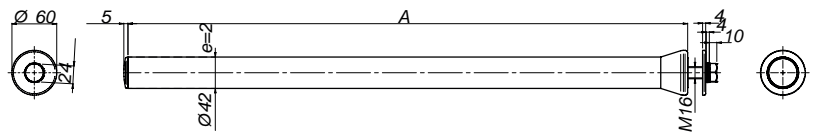

Mudguard Support Ø42 Curved Painted, no Welding
Kotflügel-Tragrohr Ø42 Gekrümmt Lackiert
Soporte Ø42 Curvado Pintado, sin Soldaduras

NEW

Ref	Kg	Mat	Sup/Finish Acabado	Col	A	B	Ø	Thickn. Espesor	Metric	Lot
0106358	1.78	STEEL	Paint	Black	580	305	42	2	M16	1
0106373	2.04	STEEL	Paint	Black	730	455	42	2	M16	1

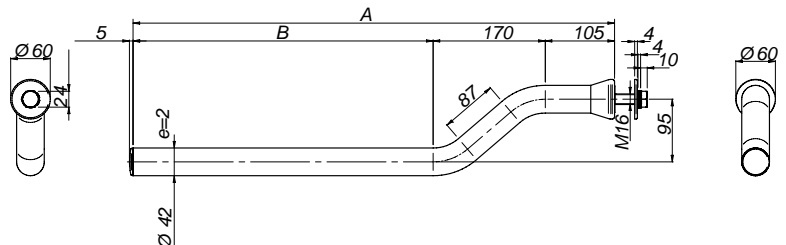

SUPPORTS AND CLAMPS / KOTFLÜGELHALTER UND BEFESTIGUNG / SOPORTES Y BRIDAS



MUDGUARDS AND WEDGES / KOTFLÜGEL UND RADKEILE / GUARDABARROS, SOPORTES, CALZOS

Mudguard Support Ø42 with Base
Kotflügel-Tragrohr Ø42 mit Flansch
Soporte Guardabarros Ø42 c/Base

Ref	Kg	Mat	Sup/Finish Acabado	Col	Ø	Lot
0106041	1.75	STEEL			42	2
0106045	1.82	STEEL	KTU		42	1

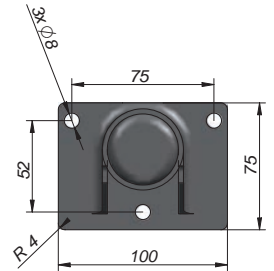
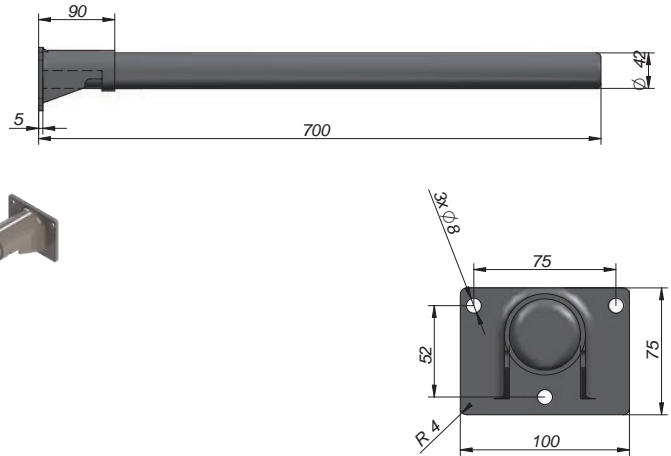

Mudguard Support Direct Attachment Ø42 with hole
Kotflügel-Tragrohr Ø42 mit Verschraubung mit löcher
Soporte Guardabarros Fij. Dir. Ø42 c/Agujero

Ref	Kg	Mat	Sup/Finish Acabado	Ø	Thickn. Espesor	Metric	Lot
0106035	1.1	STEEL		42	2.5	M16	1

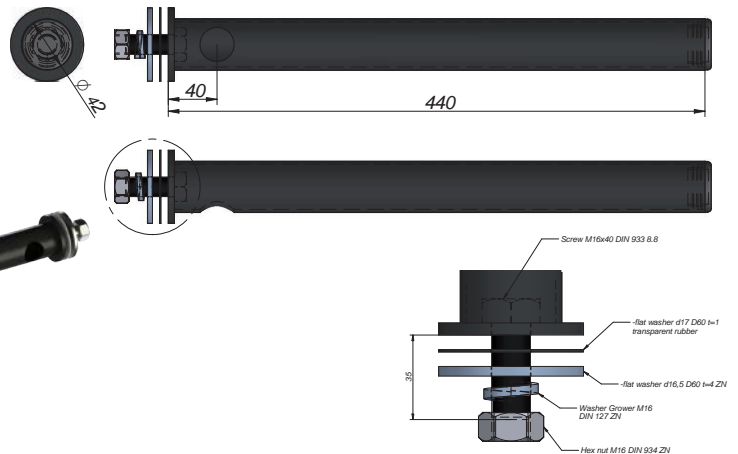

Mudguard Support Ø42 Black Painted, Direct Attachment
Kotflügel-Tragrohr Ø42 Lackiert Schwarz mit Verschraubung
Soporte Guardabarros Ø42 Pintado Negro, Fijación Directa

Ref	Kg	Mat	Sup/Finish Acabado	Col	A	Ø	Thickn. Espesor	Metric	Lot
0106020	1.05	STEEL			470	42	2.5	M16	1
0106040	1.1	STEEL			440	42	2.5	M16	1
0106046	2.45	STEEL			850	42	2.5	M16	1

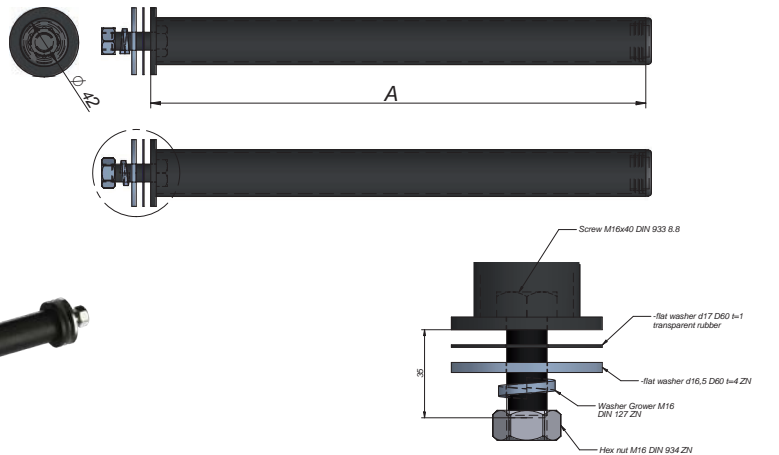

Plastic Cap for Mudguard Support (Ø42)
Kunststoffkappe für Kotflügel-Tragrohr (Ø42)
Tapón Plástico Soporte Guardabarros (Ø42)

Ref	Kg	Mat	Col	Ø	Lot	Pack
0106131	0.03			42	1	4





SUPPORTS AND CLAMPS / KOTFLÜGELHALTER UND BEFESTIGUNG / SOPORTES Y BRIDAS

MUDGUARDS AND WEDGES / KOTFLÜGEL UND RADKEILE / GUARDABARRROS, SOPORTES, CALZOS

Mudguard Support Ø42 Curved Zinc Plated
Kotflügel-Tragrohr Ø42 Gekrümmt Verzinkt
Soporte Guardabarros Ø42 Curvado Cincado

NEW

Ref	Kg	Mat	Sup/Finish Acabado	Col	Ø	Thickn. Espesor	Lot
0106010	1.35	STEEL	Zn	Ag	42	2	1

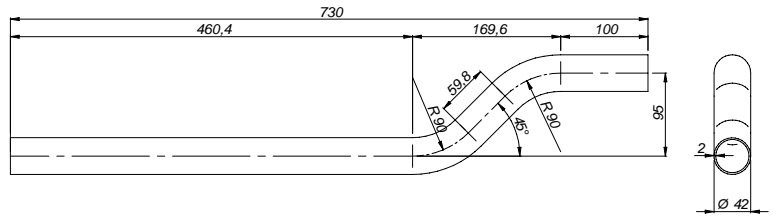
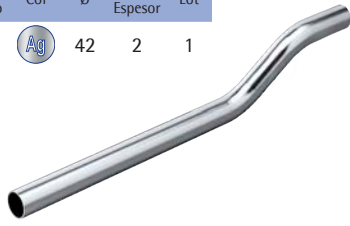

Plastic Cap for Mudguard Support 0106010 (Ø42)
Kunststoffkappe für Kotflügel-Tragrohr 0106010 (Ø42)
Tapón Plástico Soporte Guardabarros 0106010 (Ø42)

NEW

Ref	Kg	Mat	Col	Ø	Lot
0106030	0.02		Black	42	1



Zinc Plated Steel Mudguard Support Base (Ø42)
Anschraubflansch für Kotflügel-Tragrohr (Ø42) Verzinkt Stahl
Base Soporte Guardabarros (Ø42) Acero Cincado

NEW

Ref	Kg	Mat	Sup/Finish Acabado	Col	Ø	Lot
0106082	0.76	STEEL	Zn	Grey	42	1

For 0106010 Support
Para Soporte 0106010

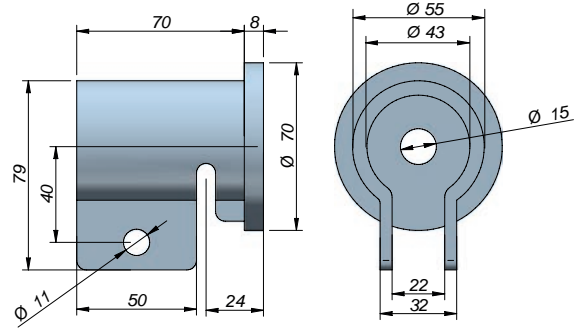

Raw Mudguard Support Base (Ø42)
Anschraubflansch für Kotflügel-Tragrohr (Ø42) Stahl
Base Soporte Guardabarros (Ø42) Acero Bruto

Ref	Kg	Mat	Ø	Lot
0106086	0.49	STEEL	42	1

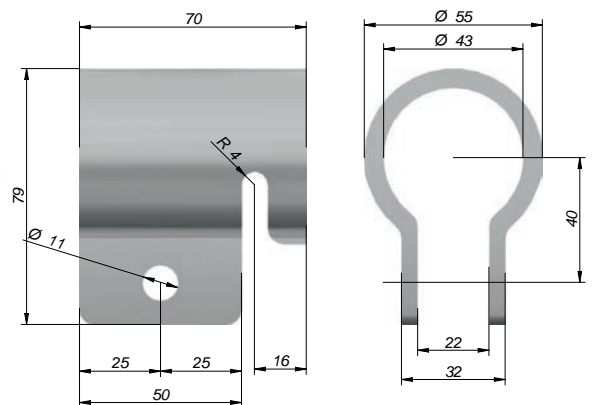
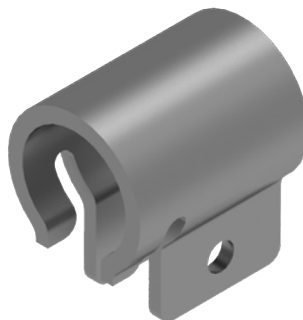

Plastic Mudguard Support Base (Ø42)
Stützeboden für Kotflügel (Ø42) Kunststoff Dreieckig
Base Soporte Guardabarros (Ø42) Plástico Triangular

Ref	Kg	Mat	Col	Ø	Lot
0106087	0.25		Black	42	2

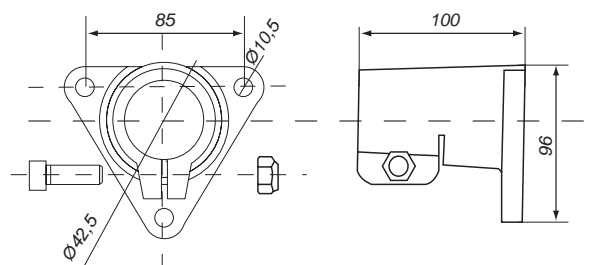

Tandem Mudguard Support 740xØ54 without Base
Kotflügel-Tragrohr mit Halterung 740xØ54 -Ohne Flansch
Soporte Guardabarros Tandem 740xØ54 s/Base

Ref	Kg	Mat	Sup/Finish Acabado	Col	Ø	Thickn. Espesor	Lot
0106090	5.3	STEEL	Zn	Ag	54	2	1

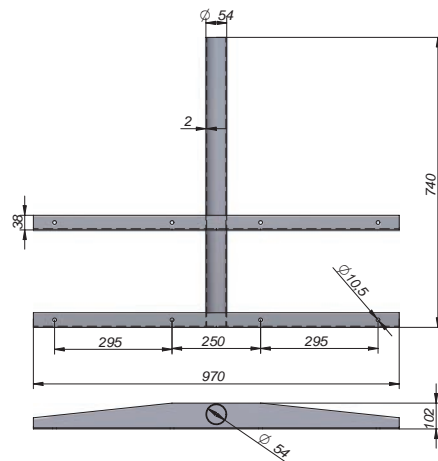
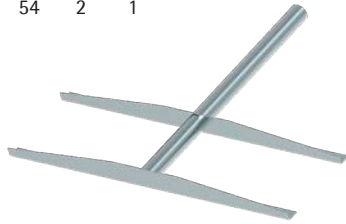

Standard Mudguard Support 740xØ54 without Base
Kotflügel-Tragrohr mit Halterung 740xØ54 -Ohne Flansch
Soporte Guardabarros Estándar 740xØ54 s/Base

Ref	Kg	Mat	Sup/Finish Acabado	Col	Ø	Thickn. Espesor	Lot
0106070	3.34	STEEL	Zn	Ag	54	2	1

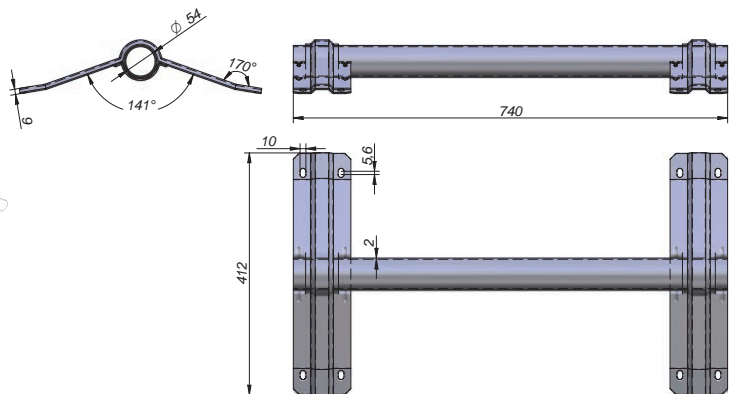

Plastic Cap for Mudguard Support (Ø54)
Kunststoffkappe für Kotflügel-Tragrohr (Ø54)
Tapón Soporte Guardabarros (Ø54) Plástico

Ref	Kg	Mat	Col	Ø	Lot
0106032	0.03		Black	54	4

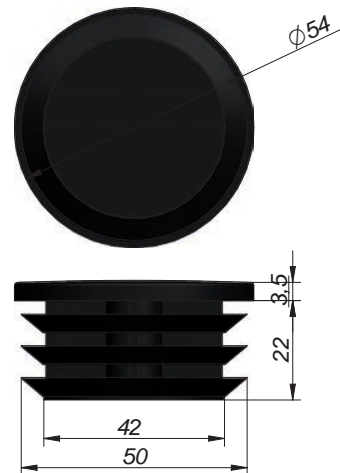

Zinc Plated Mudguard Support Base (Ø54)
Anschraubflansch für Kotflügel-Tragrohr (Ø54)
Base Soporte Guardabarros (Ø54) Cincado Rectangular

Ref	Kg	Mat	Sup/Finish Acabado	Col	Ø	Thickn. Espesor	Lot
0106080	0.92	STEEL	Zn	Ag	54	2.5	2

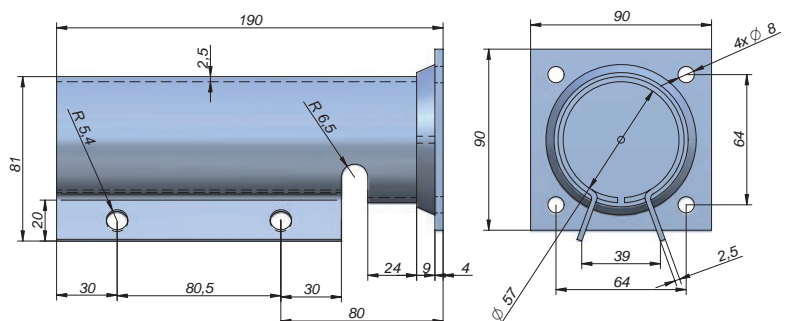



SUPPORTS AND CLAMPS / KOTFLÜGELHALTER UND BEFESTIGUNG / SOPORTES Y BRIDAS

MUDGUARDS AND WEDGES / KOTFLÜGEL UND RADKEILE / GUARDABARROS, SOPORTES, CALZOS

Mudguard Support Rectangular Adjustable
Kotflügel Halter Rechteckig Verstellbar
Soporte Guardabarras Rectangular Regulable

NEW

Ref	Kg	Mat	Sup/Finish Acabado	Thickn. Espesor	Lot
0106092	1.9	STEEL	Zn	3	1

Suitable for other applications | Finish: Zinc Plated Steel+Sealant
Apto para otras aplicaciones | Acabado: Cincado+Sellado

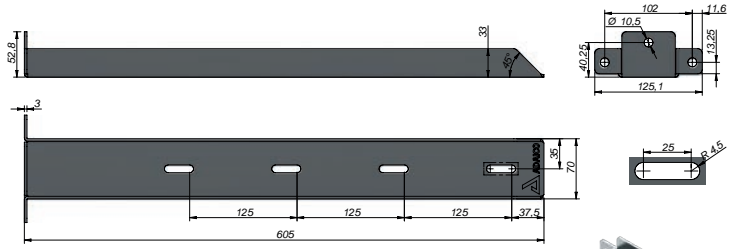

- Regulable a diferentes medidas
- Regulable a diferentes medidas

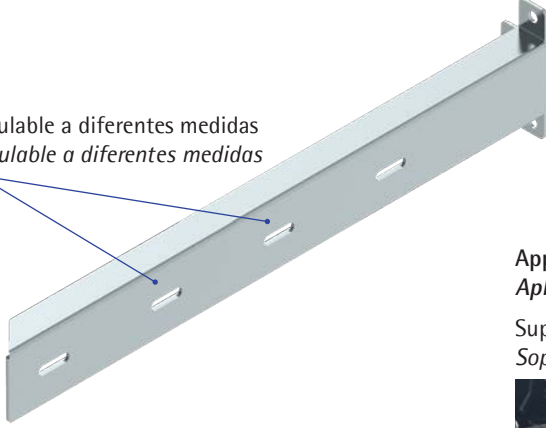

Applications
Aplicaciones

Support for Plane Mudguard
Soporte para Guardabarras Plano

Support for Plastic Box
Soporte para Cajón de Plástico



- ✓ Quick and easy chassis mounting
- ✓ No clamps needed.
- ✓ Screwable or Weldable.
- ✓ Time saving.

- ✓ Montaje a chasis fácil y rápido
- ✓ No necesita bridas.
- ✓ Atornillable o Soldable.
- ✓ Ahorro de tiempo.

Mudguard Support Rectangular Steel
Kotflügel Halter Rechteckig Stahl
Soporte Guardabarras Rectangular Acero

NEW

Ref	Kg	Mat	Thickn. Espesor	Lot
0106094	1.9	STEEL	2	1

Magnelis® Steel
Acero Magnelis®

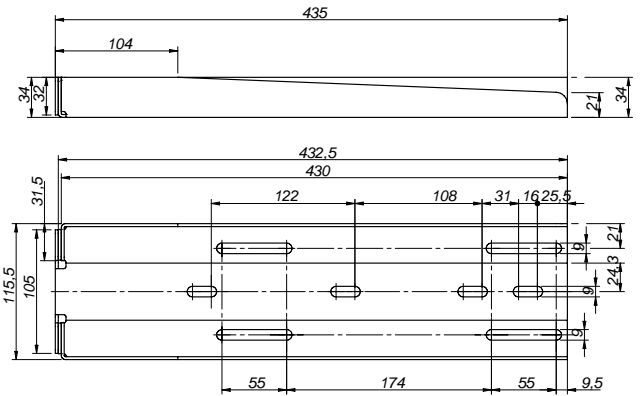
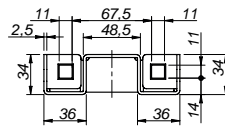

Applications
Aplicaciones

Support for Medium-Plane Mudguard
Soporte para Guardabarras Medio-Plano

Support for Plastic Box
Soporte para Cajón de Plástico



SUPPORTS AND CLAMPS / KOTFLÜGELHALTER UND BEFESTIGUNG / SOPORTES Y BRIDAS



Adjustable Mudguard Support Clamp (Ø42)
Kotflügel-Halterung Verstellbar (Ø42)
Brida Soporte Guardabarros Regulable (Ø42)

Ref	Kg	Mat	Sup/Finish Acabado	Col	Ø	Thickn. Espesor	Lot	Pack
0106147	2.27	STEEL	Zn	Ag	42	4	1	4
0106148	2.28	STEEL	KTL	Black	42	4	1	4

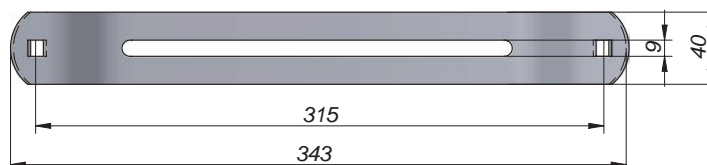
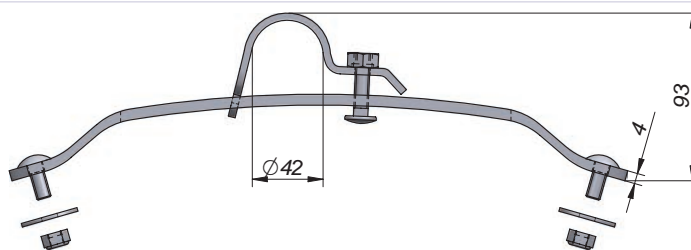

Adjustable Mudguard Support Clamp (Ø42)
Kotflügel-Halterung Verstellbar (Ø42)
Brida Soporte Guardabarros Regulable (Ø42)

Ref	Kg	Mat	Sup/Finish Acabado	Col	Ø	Thickn. Espesor	Lot
0106064	0.49	STEEL	Blue	Black	42	3	4
0106066	0.49	STEEL	Zn	Ag	42	3	4
0106067	0.49	INOX			42	3	2

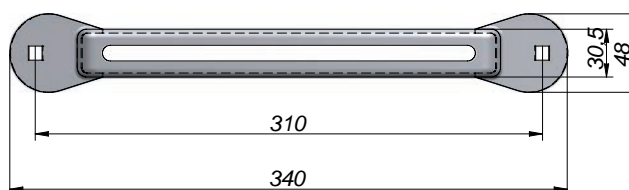
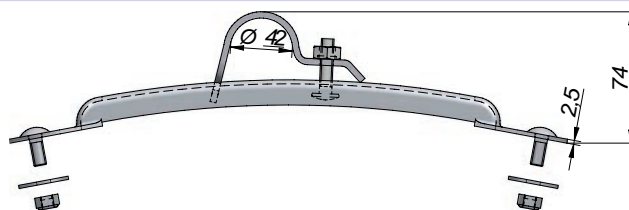

Adjustable Support Clamp (Ø42) Stainless Steel
Kotflügel-Halterung Verstellbar (Ø42), Edelstahl
Brida Regulable Soporte (Ø42) Inox

NEW

Ref	Kg	Mat	Col	Ø	Lot
0106069	0.52	INOX	Ag	42	2

Stainless Steel AISI 304 2B
Acero Inoxidable AISI 304 2B

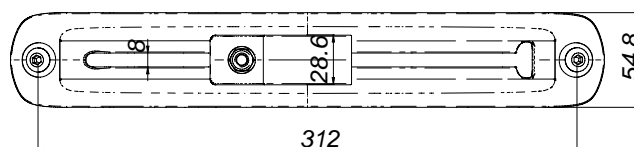
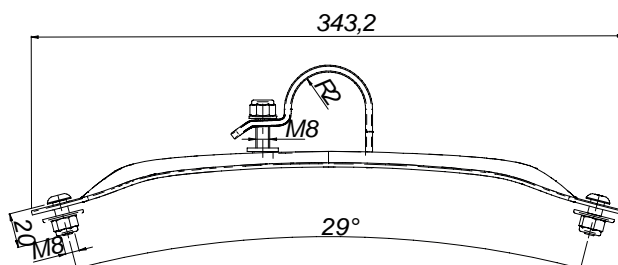

MUDGUARDS AND WEDGES / KOTFLÜGEL UND RADKEILE / GUARDABARROS, SOPORTES, CALZOS



SUPPORTS AND CLAMPS / KOTFLÜGELHALTER UND BEFESTIGUNG / SOPORTES Y BRIDAS

MUDGUARDS AND WEDGES / KOTFLÜGEL UND RADKEILE / GUARDABARRROS, SOPORTES, CALZOS

Adjustable Plastic Mudguard Support Clamp (Ø42)
Kotflügel-Halterung Verstellbar (Ø42)
Brida Soporte Guardabarros Regulable (Ø42) Plástico

Ref	Kg	Mat	Col	Ø	Thickn. Espesor	Lot	Pack
0106150	0.91			42	6	1	4

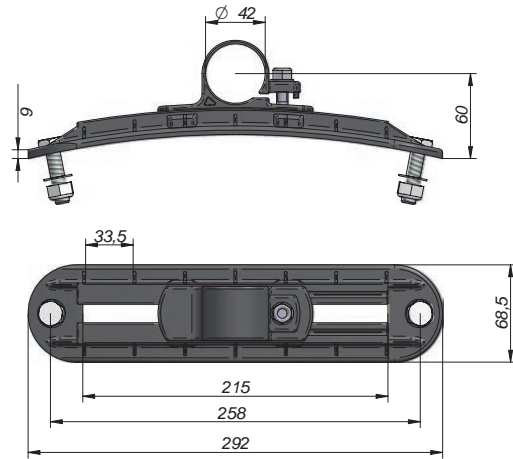

Nylon Mudguard Support Clamp Fix (Ø42)
Kotflügel-Halterung Fest (Ø42) Nylon
Brida Soporte Guardabarros Fija (Ø42) Nylon

Ref	Kg	Mat	Col	Ø	Thickn. Espesor	Lot	Pack
0106155	0.7	Ny		42	6	1	4

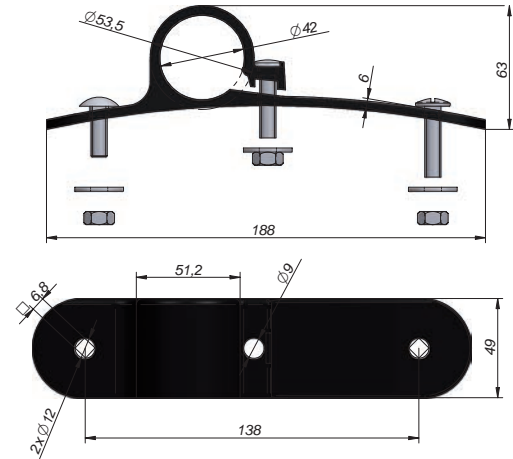

Nylon Mudguard Support Clamp Fix (Ø54)
Kotflügel-Halterung Fest (Ø54) Nylon
Brida Soporte Guardabarros Fija (Ø54) Nylon

Ref	Kg	Mat	Col	Ø	Thickn. Espesor	Lot
0106058	0.24	Ny		54	7	4

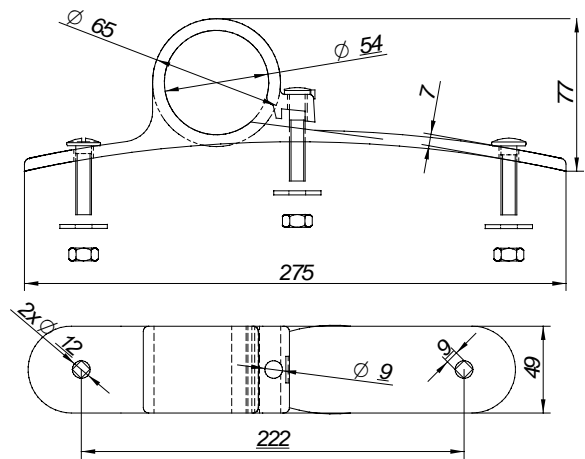

Adjustable Plastic Mudguard Support Clamp (Ø54)
Kotflügel-Halterung Verstellbar (Ø54)
Brida Soporte Guardabarros Regulable (Ø54) Plástico

Ref	Kg	Mat	Col	Ø	Thickn. Espesor	Lot
0106059	0.34			54	5	4

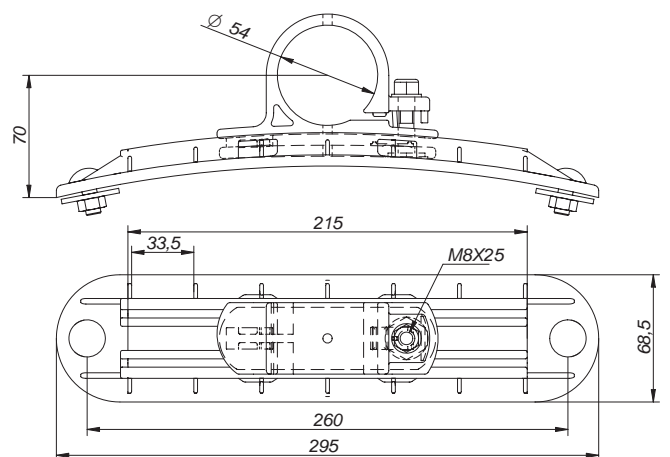



Wheel Support with Handle
E-Radwinde (335) mit Handgriff
Soporte Rueda (335) c/Manilla

Ref	Kg	Mat	Sup/Finish Acabado	Col	Lot
1101014	13.58	STEEL			1

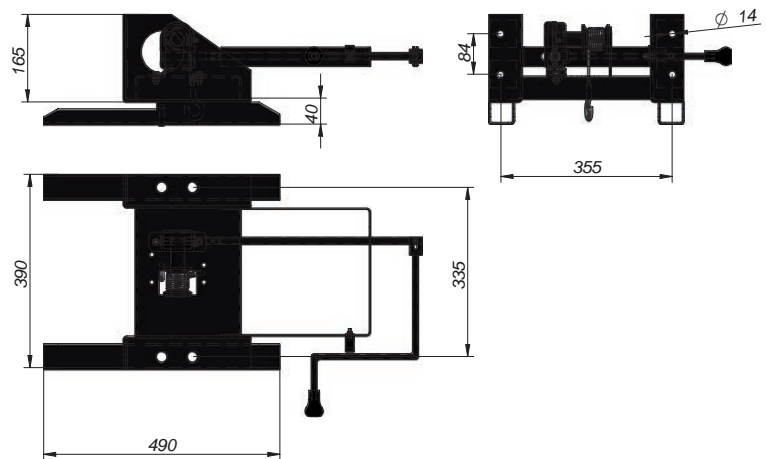

Wheel Support Base 15/22,5
Spannarm für E-Radwinde 15/22,5
Barra Alzamiento Soporte Rueda 15/22,5

Ref	Kg	Mat	Sup/Finish Acabado	Col	Lot
1101016	2.99	STEEL			1

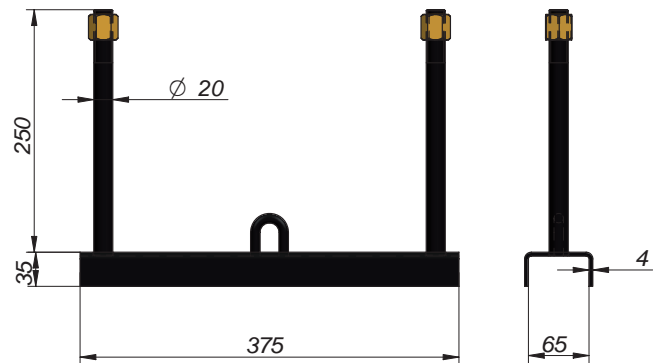
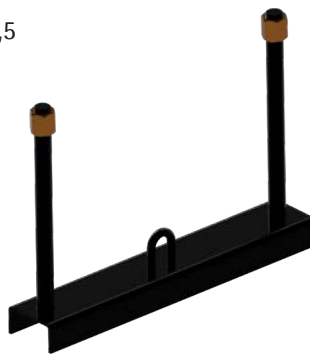

Wheel Support Base 10/22,5
Spannarm für E-Radwinde 10/22,5
Barra Alzamiento Soporte Rueda 10/22,5

Ref	Kg	Mat	Sup/Finish Acabado	Col	Lot
1101018	2.17	STEEL			1

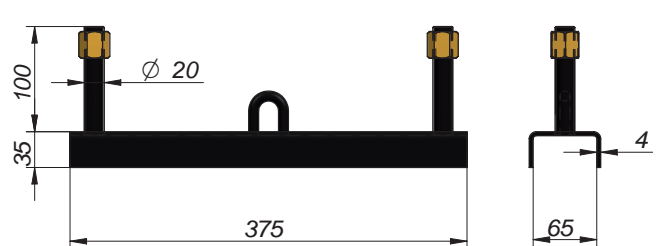



WHEEL SUPPORTS / ERSATZRADHALTER / SOPORTES DE RUEDA

MUDGUARDS AND WEDGES / KOTFLÜGEL UND RADKEILE / GUARDABARRROS, SOPORTES, CALZOS

Retainer for Tyre 385/65-R22,5
 E-Radkorb f. 385/65-R22.5
 Soporte Rueda Cesta 385/65 - R22,5

Ref	Kg	Mat	Sup/Finish Acabado	Metric	Lot
1101002	30	STEEL	Galv	M12	1

Includes Hardware Kit (9 screws + 9 stop nuts M12)
 Incluye kit de tornillería (9 tornillos + 9 tuercas autoblocantes M12)

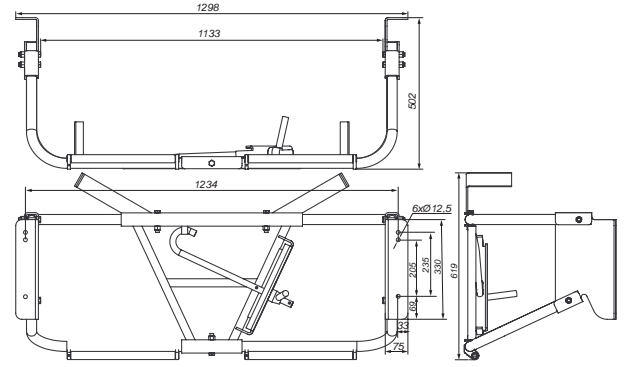

Handle+Lock Set for Retainer for Tyre 1101002
 Kurbel+Verschluss Set für E-Radkorb 1101002
 Kit Manivela+Cierre para Soporte Rueda 1101002

Ref	Kg	Mat	Sup/Finish Acabado	Lot
1101003	2.8	STEEL	Galv	1

Compatible with 1101002
 Repuesto para Soporte Cesta 1101002

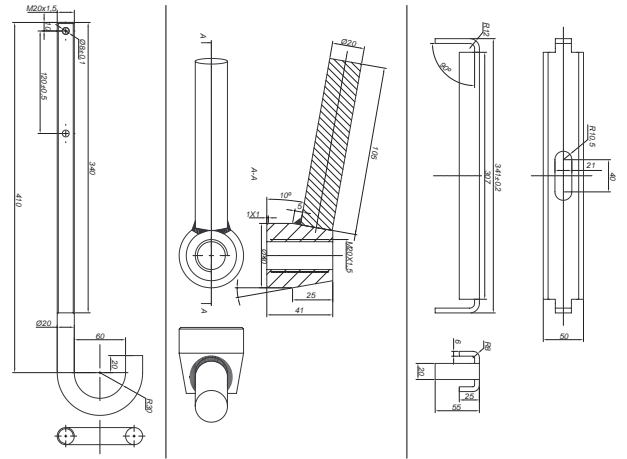

Wheel Support (225-335) Hex24/32
 E-Radwinde (225-335) Hex24/32
 Soporte Rueda (225-335) Hexagonal 24/32

Ref	Kg	Mat	Lot
1101044	13.5	STEEL	1

Test: 150 Kg. | 10 Holes
 Test: 150 Kg. | 10 Agujeros

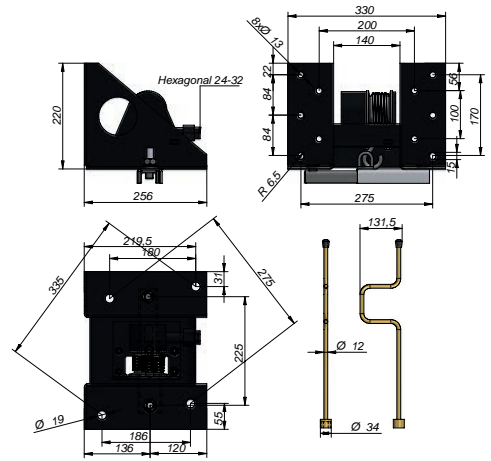

Wheel Support (152-220) Hex24 with Handlevel
 E-Radwinde (152-220) Hex24 mit Handkurbel
 Soporte Rueda (152-220) Hexagonal 24 con Manivela

Ref	Kg	Mat	Lot
1101042	5.7	STEEL	2

Test: 150 Kg. | 5/6/8 Holes
 Test: 150 Kg. | 5/6/8 Agujeros

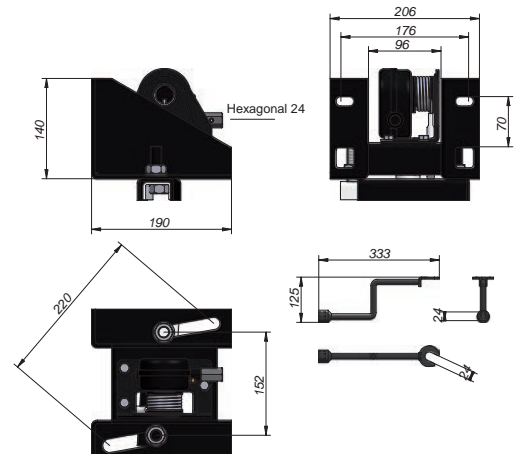



Wheel Elevator Endless (Hx 27/32) Cable 1000
 Radwinde Endlos (Hx 27/32) Kabel 1000
 Sinfin Elevarruedas (Hexagonal 27/32) Cable 1000

Ref	Kg	Mat	Sup/Finish Acabado	Lot
1101080	1.9	STEEL		1

Test: 150 Kg. | Cable 1.000 mm.

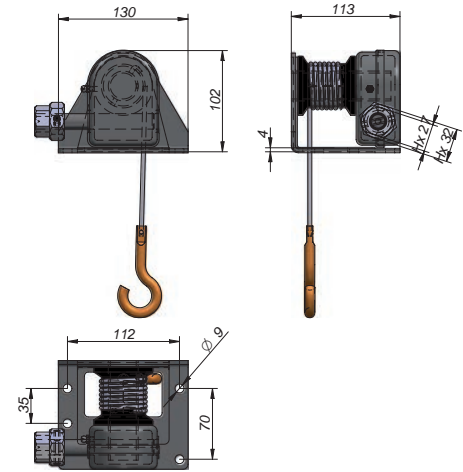

Wheel Elevator Endless (Hx 18) Cable 1000
 Radwinde Endlos (Hx 18) Kabel 1000
 Sinfin Elevarruedas (Hexagonal 18) Cable 1000

Ref	Kg	Mat	Sup/Finish Acabado	Lot
1101086	1.81	STEEL		1

Test: 150 Kg. | Cable 1.000 mm.

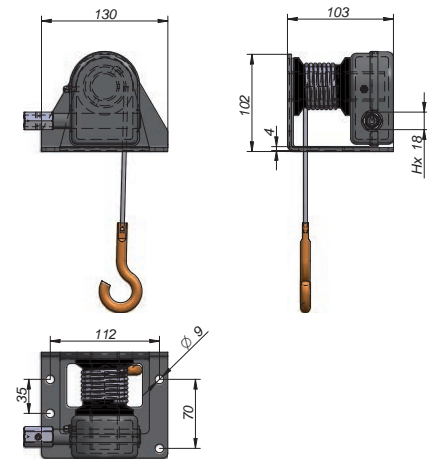

MUDGUARDS AND WEDGES / KOTFLÜGEL UND RADKEILE / GUARDABARRROS, SOPORTES, CALZOS



R53

Plastic Yellow Chock R555 DIN 76051
 Radkeil R555 Plastik Gelb DIN 76051
 Calzo Rueda R555 DIN 76051 Plástico Amarillo

Ref	Kg	Mat	Col	Radio	Article	Lot
1102132	1.4	PP	Yellow	555	With metal insert Con inserto metálico	1
1102133 NEW	1.19	PP	Yellow	555		1

DIN 76051

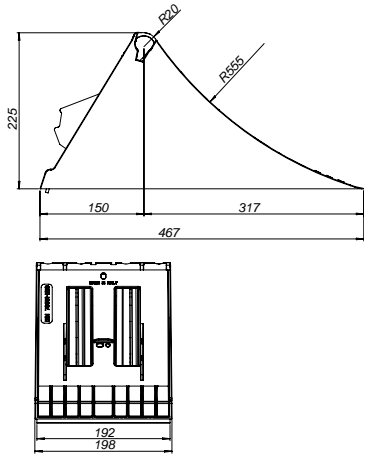

Plastic Holder for Chock 1102132
 Radkeilhalter Kunststoff für Radkeil 1102132
 Soporte de Plástico para Calzo 1102132

Ref	Kg	Mat	Lot
1102138	0.59	PP	2

New Design, double security: The fixing of the handle is done directly in the wedge by means of a security pin
 Nuevo Diseño, doble seguridad: La fijación del asa se realiza directamente en el calzo mediante un pin de seguridad

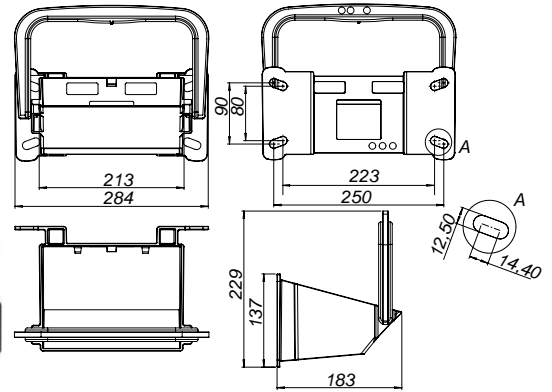

Black Steel Holder for Chock 1102132
 Radkeilhalter Stahl Schwarz für Radkeil 1102132
 Soporte Acero Negro para Calzo 1102132

Ref	Kg	Mat	Col	Lot
1102139	1.23	STEEL	Black	2

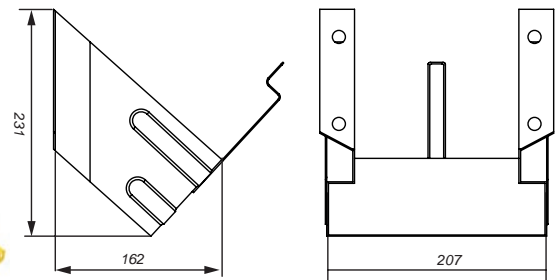



MUDGUARDS AND WEDGES / KOTFLÜGEL UND RADKEILE / GUARDABARRROS, SOPORTES, CALZOS

Folding Chock R560 DIN 76051
 Radkeil Klappbar R560 DIN 76051
 Calzo Rueda Plegable R560 DIN 76051

Ref	Kg	Mat	Col	Radio	Lot
1102136	0.91			560	1

With metal insert
 Con inserto metálico
 DIN 76051

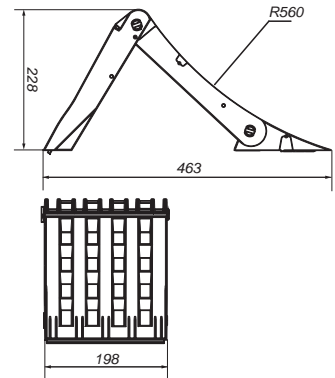

Magnelis Wedge Support for 1102136
 Radkeilhalter Magnelis für 1102136
 Soporte Calzo Magnelis para 1102136

Ref	Kg	Mat	Lot
1102141	1.54		1

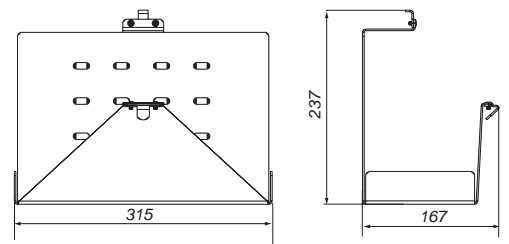

Anodized Aluminium Wedge Support L=70 for 1102136
 Radkeilhalter L=70 für 1102136, Aluminium Eloxiert
 Soporte Calzo L=70 para 1102136, Aluminio Anodizado

Ref	Kg	Mat	Sup/Finish Acabado	Lot
1102142	0.16			1

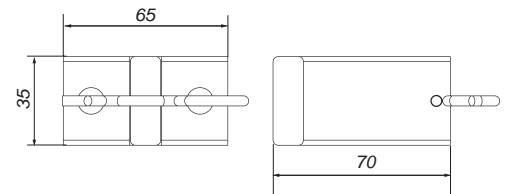

Anodized Aluminium Wedge Support L=126 for 1102136
 Radkeilhalter L=126 für 1102136, Aluminium Eloxiert
 Soporte Calzo L=126 para 1102136, Aluminio Anodizado

Ref	Kg	Mat	Sup/Finish Acabado	Lot
1102143	0.23			1

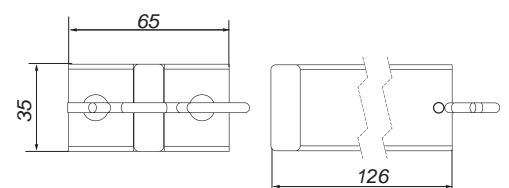



WEDGES / HEMMSCHUHE / CALZOS

MUDGUARDS AND WEDGES / KOTFLÜGEL UND RADKEILE / GUARDABARRROS, SOPORTES, CALZOS



R46

Plastic Yellow Chock R460 DIN 76051
Radkeil R460 Plastik Gelb DIN 76051
Calzo Rueda R460 DIN 76051 Plástico Amarillo

Ref	Kg	Mat	Col	Radio	Article	Lot
1102130	0.84	PP	Yellow	460	With metal insert Con inserto metálico	1
1102131 NEW	0.75	PP	Yellow	460		1

DIN 76051

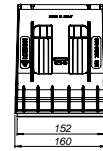
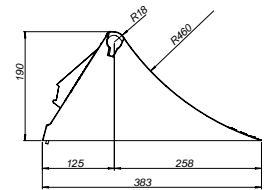

Galvanized Steel Chock R460 DIN 76051
Radkeil Galvanisiert R460 DIN 76051
Calzo Rueda Galvanizado R460 DIN 76051

Ref	Kg	Mat	Sup/Finish Acabado	Col	Radio	Lot
1102110	3.06	STEEL	Galv	Ag	460	1

Maximum Load: 5.000 Kg.
Carga máxima: 5.000 Kg.
DIN 76051

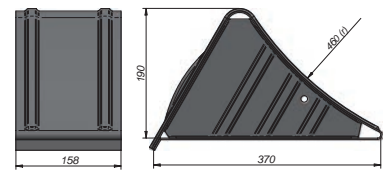

Galvanized Steel Holder for Chock 1102110
Radkeilhalter Feuerverzinkt für Radkeil 1102110
Soporte Galvanizado para Calzo 1102110

Ref	Kg	Mat	Sup/Finish Acabado	Thickn. Espesor	Lot
1102120	0.5	STEEL	Galv	1.2	1

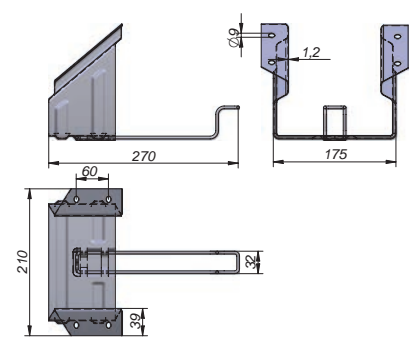
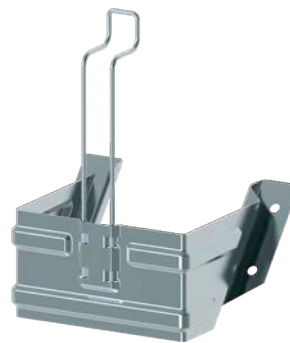

Plastic Fix Support for Chock 1102130
Hemmschuh-Halter aus Kunststoff für 1102130
Soporte de Fijación en plástico para calzo 1102130

Ref	Kg	Mat	Ø	Article	Lot
1102148	0.16	PP	55		1

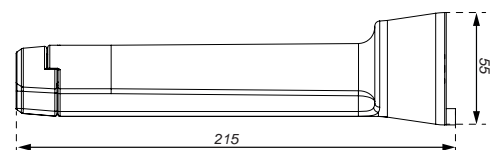



R36

Plastic Yellow Chock R355 DIN 76051
 Radkeil R355 Plastik Gelb DIN 76051
 Calzo Rueda R355 DIN 76051 Plástico Amarillo

Ref	Kg	Mat	Col	Radio	Lot
1102134	0.52			360	1

With metal insert
 Con inserto metálico
 DIN 76051

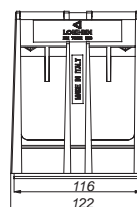
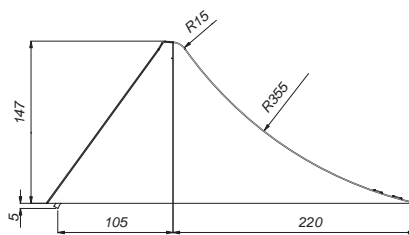

Galvanized Steel Wedge Support for 1102134
 Radkeilhalter Feuerverzinkt für 1102134
 Soporte Calzo Galvanizado para 1102134

Ref	Kg	Mat	Sup/Finish Acabado	Lot
1102144	0.32			1

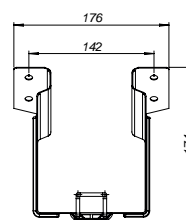
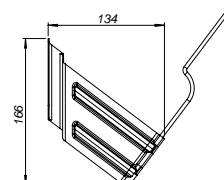
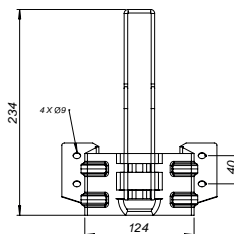
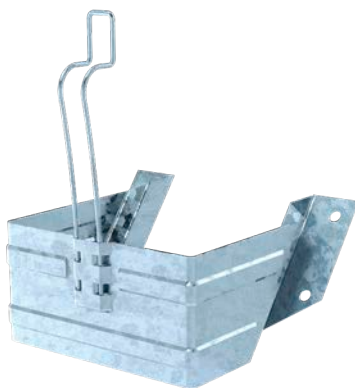

Plastic Support for Chock 1102134
 Radkeilhalter Kunststoff für 1102134
 Soporte Calzo de Rueda p/1102134

Ref	Kg	Mat	Col	Lot
1102147	3.96			1

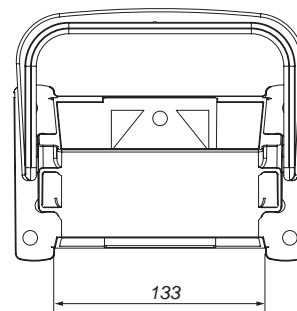
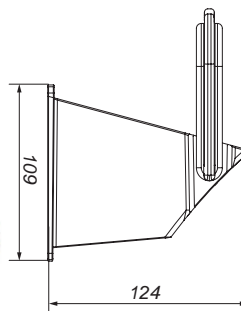



WEDGES / HEMMSCHUHE / CALZOS

MUDGUARDS AND WEDGES / KOTFLÜGEL UND RADKEILE / GUARDABARRROS, SOPORTES, CALZOS



Chock For Transport of Vehicles
Hemmschuh für Fahrzeugtransport
Calzo de mano Porta Vehículos

Ref	Kg	Mat	Pos	Lot
1102101	2.7	STEEL		1
1102102	2.7	STEEL		1

1102101 - L

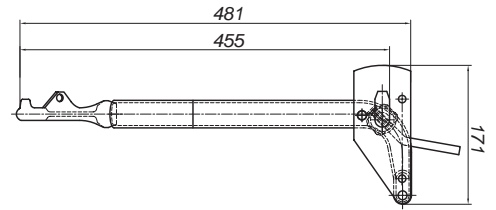
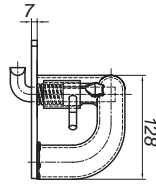

1102102 - R

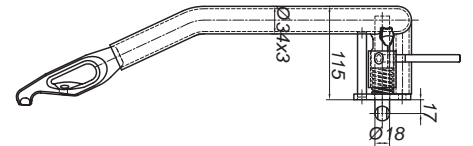

Chock For Transport of Vehicles
Hemmschuh für Fahrzeugtransport
Calzo Porta Vehículos

Ref	Kg	Mat	Sup/Finish Acabado	Lot
1102106	4.15	STEEL	Zn	1

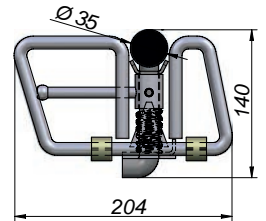
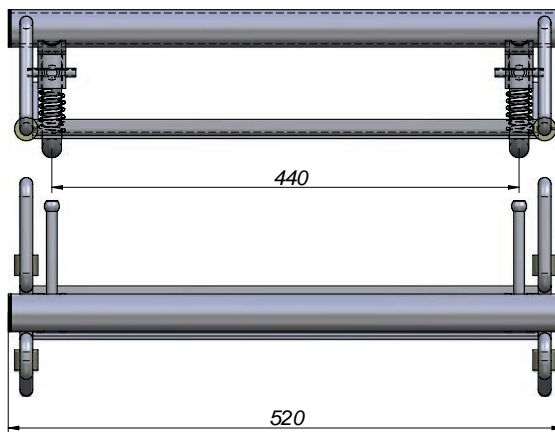

Chock For Transport of Vehicles
Hemmschuh für Fahrzeugtransport
Calzo Rueda Sujeción Turismo

Ref	Kg	Mat	Sup/Finish Acabado	Lot
1102108	4	STEEL	Zn	1

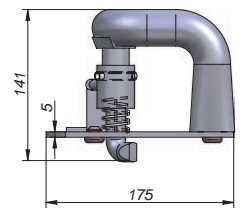
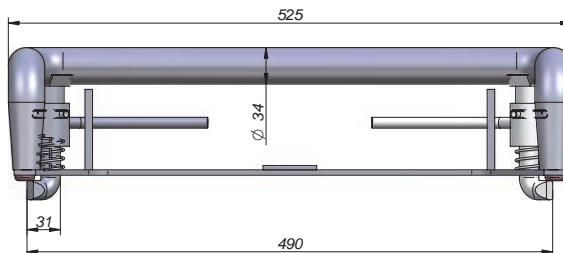
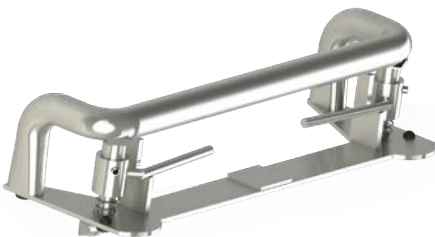

Cajones y Bidones

Boxes and Tanks

Boîtes et Réservoirs

Kästen und Wassertanks

Caixas e Bidões



Cajón Metálico ADABOX
Steel Toolbox ADABOX
Coffre Acier ADABOX
Werkzeugkästen Stahl ADABOX
Caixa Ferramentas Aço ADABOX



pag. 86-101

Cajón De Plástico
Plastic Toolbox
Coffre Plastique
Werkzeugkästen Kunststoff
Caixa Ferramentas Plástico

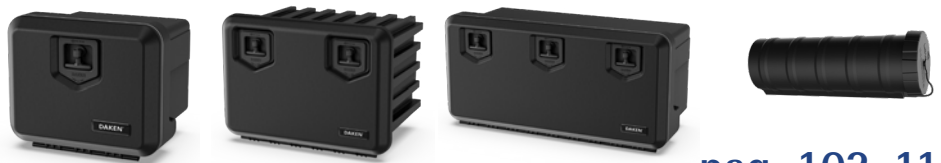

pag. 102-110

Accesorios Cajon Herramientas
Toolbox Accessories
Accessoires Coffres
Werkzeugkofferzubehör
Acessórios Caixa Ferramentas



pag. 111-117

Cajón Extintor
Fire Extinguisher Toolbox
Coffres Extincteur
Feuerlöscherkästen
Caixa Extintor



pag. 118-124

Accesorios Cajón Extintor
Fire Extinguisher Accessories
Accessoires Coffres Extincteur
Feuerlöscherszubehör
Acessórios Caixa Extintor



pag. 125-16

Extintores
Fire Extinguishers
Extincteur
Feuerlöscher
Extintores



pag. 127-129

Bidones
Tanks
Bidons
Wassertanks
Bidões



pag. 130-137

Portamangueras
Hose Tube Holder
Fourreau De Tuyau
Schlauchrohrbehälter
Porta Mangueiras



pag. 138



STEEL TOOL ADABOX / WERKZEUGKÄSTEN STAHL ADABOX / CAJÓN METÁLICO ADABOX

BOXES AND TANKS / WERKZEUGKÄSTEN UND WASSERTANKS / CAJONES Y BIDONES



HOMOLOGATION / HOMOLOGACIÓN
European Regulation R-73
Reglamento Europeo R-73



MATERIALS / MATERIALES

Galvanized Steel Black Epoxy Paint & Stainless Steel
Acero Galvanizado Pintura Epoxy Negro





ADVANTAGE / VENTAJAS

LOCK CIERRE

Ergonomic & Double Security (key & ring for padlock).
Ergonómico & Doble Seguridad (llave + anilla candado).



DOOR TAPA

Optional gas springs or cable.
Opción amortiguador o cable.

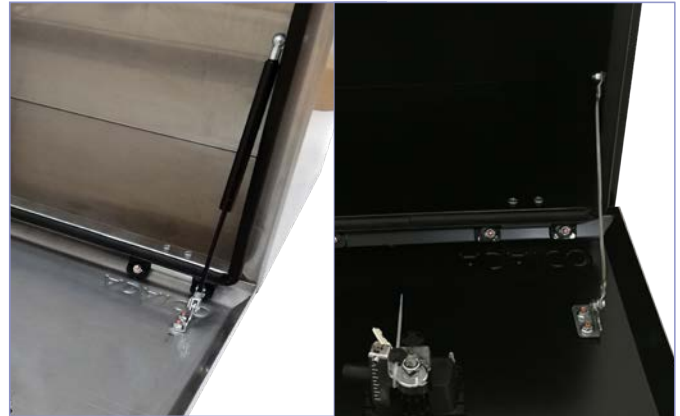

SEALING & CONTINUOUS WELDING ESTANQUEIDAD Y SOLDADURA CONTINUA

Rubber seal and continuous welding.
Junta de goma y soldadura continua.



CUSTOMIZED BOXES CAJONES PERSONALIZADOS

Gas springs, shelves, aerators, etc.
Amortiguadores, repisas, aireadores, etc.

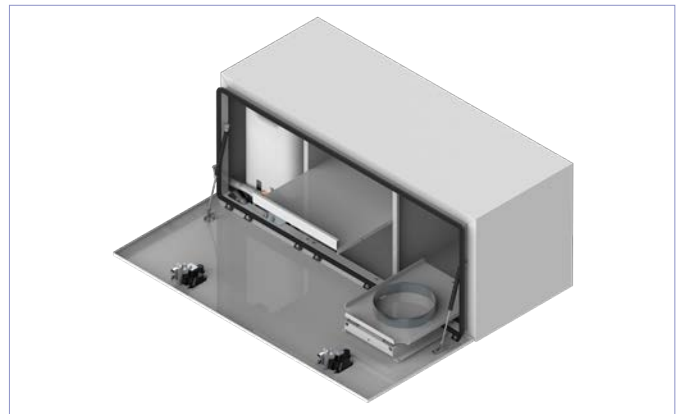

METALLIC HINGES BISAGRAS METÁLICAS

Metallic hinges and copper-plated steel screws.
Bisagras metálicas y tornillería de acero cobreado.



PERFECT FINISHES ACABADOS PERFECTOS



STEEL TOOL ADABOX / WERKZEUGKÄSTEN STAHL ADABOX / CAJÓN METÁLICO ADABOX

ADABOX  Inoxydable Mat / Inoxidable Mate (1,2 mm.)

BOXES AND TANKS / WERKZEUGKÄSTEN UND WASSERTANKS / CAJONES Y BIDONES







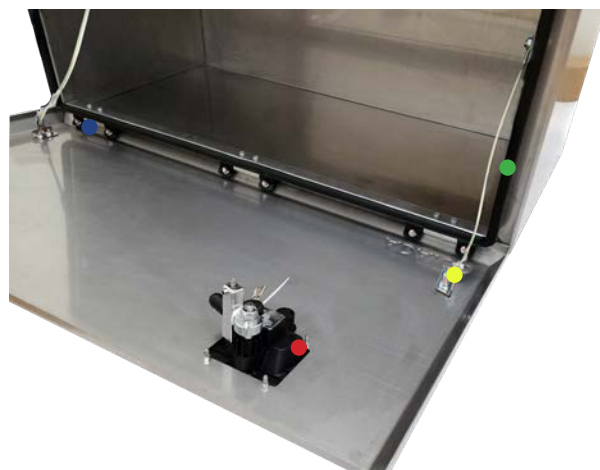

- ✓ MATERIAL / MATERIAL:
 - Body-Cover / Cuerpo-Tapa: Stainless Steel AISI 304/X5CrNi1 8-10/1,4301
- ✓ THICKNESS / ESPESOR:
 - Body / Cuerpo: 1.2 mm.
 - Cover / Tapa: 2 mm.
- ✓ HOMOLOGATION / HOMOLOGACIÓN:  ECE-R73.01
- ✓ PRODUCTION PROCESS: / PROCESO FABRICACIÓN: Continuous welding / Soldadura continua

Accessories Accesorios		Ref.	
•	Metallic hinge <i>Metallscharnier</i> Bisagra metálica	0298020	
•	Lock <i>Verschluss</i> Cierre	1203001	
•	Rubber seal <i>Gummidichtung</i> Junta de goma	0298004	
•	Steel Cable <i>Stahlkabel</i> Cable acero	0298024	
•	Brackets <i>Halterung</i> Soporte	0201498	







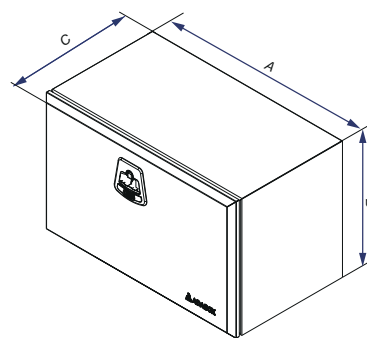

ADABOX Matt Stainless Steel Box (1,2 mm.)
ADABOX Werkzeugkasten Edelstahl Matt (1,2 mm.)
Cajón ADABOX Inox Liso Mate (1,2 mm.)

Ref	Kg	Mat	Sup/Finish Acabado	A	B	C	Thickn. Espesor	E-mark	Part	Lot
0282360	14.6	INOX		500	400	470	1.2			1
0282340	16.4	INOX		600	400	470	1.2			1

ECE-R73.01 Lateral Protection Devices



ADABOX Matt Stainless Steel Box (1,2 mm.)
ADABOX Werkzeugkasten Edelstahl Matt (1,2 mm.)
Cajón ADABOX Inox Liso Mate (1,2 mm.)

Ref	Kg	Mat	Sup/Finish Acabado	A	B	C	Thickn. Espesor	E-mark	Part	Lot
0282322	22.8	INOX		800	500	470	1.2			1
0282300	28	INOX		1000	500	470	1.2			1

Ergonomic & Double Security Lock (key & ring for padlock) | Optional gas springs or cable |
Metallic hinges and copper-plated steel screws | Sealing
Cierre Ergonómico Doble Seguridad (llave+anillo candado) | Opción amortiguador o cable |
Bisagras metálicas, tornillería acero cobreado | Estanqueidad

ECE-R73.01 Lateral Protection Devices

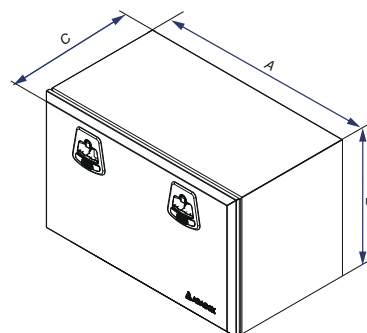



STEEL TOOL ADABOX / WERKZEUGKÄSTEN STAHL ADABOX / CAJÓN METÁLICO ADABOX



Black Galvanized / Galvanizado Negro (1,2 mm.)







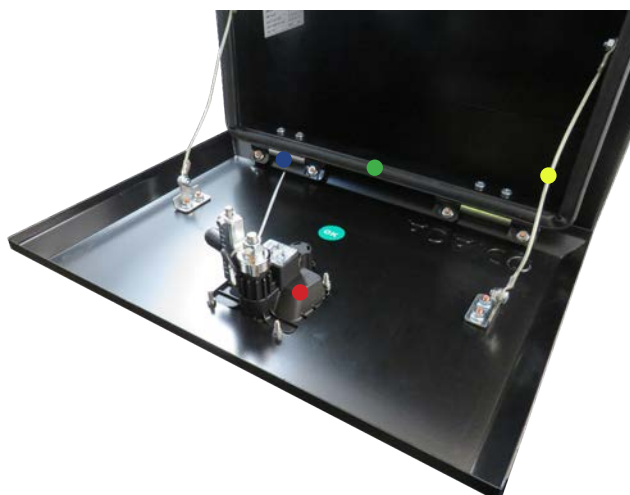

- ✓ MATERIAL / MATERIAL:
 - Body-Cover / Cuerpo-Tapa: Galvanized Steel Dx51D-Z275 Black Powder Coated
- ✓ THICKNESS / ESPESOR:
 - Body / Cuerpo: 1.2 mm.
 - Cover / Tapa: 2 mm.
- ✓ HOMOLOGATION / HOMOLOGACIÓN: ECE-R73.01 
- ✓ PRODUCTION PROCESS / PROCESO FABRICACIÓN: Continuous welding / Soldadura continua

Accessories Accesorios		Ref.	
●	Metallic hinge Metallscharnier Bisagra metálica	0298020	
●	Lock Verschluss Cierre	1203001	
●	Rubber seal Gummidichtung Junta de goma	0298004	
●	Steel Cable Stahlkabel Cable acero	0298024	
	Brackets Halterung Soporte	0201498	





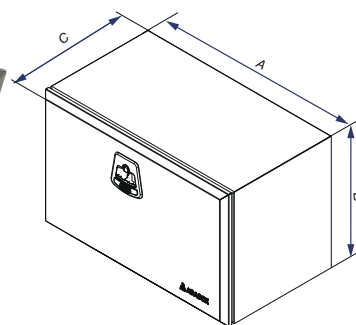

ADABOX Galvanized Steel Black Box (1,2 mm.)
ADABOX Werkzeugkasten Verzinkt Schwarz (1,2 mm.)
Cajón ADABOX Acero Galvanizado Negro (1,2 mm.)

Ref	Kg	Mat	Sup/Finish Acabado	Col	A	B	C	Thickn. Espesor	E-mark	Part	Lot
0282101	8	STEEL	Galv	●	400	300	300	1.2			1
0282103	12	STEEL	Galv	●	500	350	400	1.2			1
0282105	15.7	STEEL	Galv	●	600	400	470	1.2			1

ECE-R73.01 Lateral Protection Devices



ADABOX Galvanized Steel Black Box (1,2 mm.)
ADABOX Werkzeugkasten Verzinkt Schwarz (1,2 mm.)
Cajón ADABOX Acero Galvanizado Negro (1,2 mm.)

Ref	Kg	Mat	Sup/Finish Acabado	Col	A	B	C	Thickn. Espesor	E-mark	Part	Lot
0282107	22	STEEL	Galv	●	800	500	470	1.2			1
0282109	25.3	STEEL	Galv	●	960	500	470	1.2			1

Ergonomic & Double Security Lock (key & ring for padlock) | Metallic hinges and copper-plated steel screws | Continuous Welding | Interior Seal
Cierre Ergonómico Doble Seguridad (llave+anillo candado) | Bisagras metálicas, tornillería acero cobreado | Soldadura continua | Junta de goma
ECE-R73.01 Lateral Protection Devices

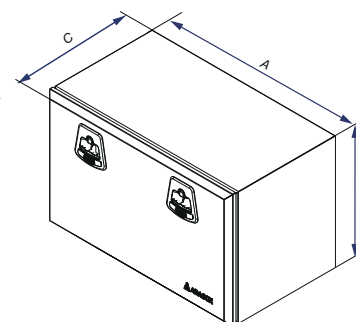

BOXES AND TANKS / WERKZEUGKÄSTEN UND WASSERTANKS / CAJONES Y BIDONES



STEEL TOOL ADABOX / WERKZEUGKÄSTEN STAHL ADABOX / CAJÓN METÁLICO ADABOX

BOXES AND TANKS / WERKZEUGKÄSTEN UND WASSERTANKS / CAJONES Y BIDONES

ADABOX Matt Stainless Steel / Inoxidable Mate (1,5 mm.)



- ✓ MATERIAL / MATERIAL:
 - Body-Cover / Cuerpo-Tapa: Stainless Steel AISI 304/X5CrNi1 8-10/1,4301
- ✓ THICKNESS / ESPESOR:
 - Body / Cuerpo: 1.5 mm.
 - Cover / Tapa: 2 mm.
- ✓ HOMOLOGATION / HOMOLOGACIÓN: ECE-R73.01
- ✓ PRODUCTION PROCESS: / PROCESO FABRICACIÓN: Continuous welding / Soldadura continua

Accessories Accesorios		Ref.	
●	Metallic hinge Metallscharnier Bisagra metálica	0298020	
●	Lock Verschluss Cierre	1203001	
●	Rubber seal Gummidichtung Junta de goma	0298004	
●	Steel Cable o Gas Spring Stahlkabel o Gasfeder Cable acero o Amortiguador	0298024 0298011	
	Brackets Halteung Soporte	0201498	



ADABOX Matt Stainless Steel Box (1,5 mm.) ADABOX Werkzeugkasten Edelstahl Matt (1,5 mm.) Cajón ADABOX Inox Liso Mate (1,5 mm.)

Ref	Kg	Mat	Sup/Finish Acabado	A	B	C	Thickn. Espesor	E-mark	Part	Lot
0282364	14.6	INOX		500	350	400	1.5			1
0282344	20	INOX		600	400	500	1.5			1

ECE-R73.01 Lateral Protection Devices

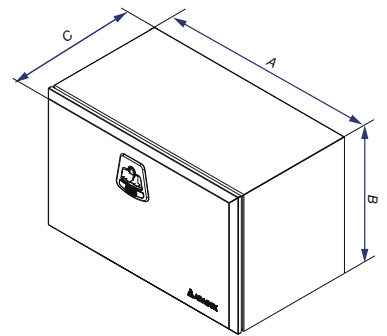

ADABOX Matt Stainless Steel Box (1,5 mm.) ADABOX Werkzeugkasten Edelstahl Matt (1,5 mm.) Cajón ADABOX Inox Liso Mate (1,5 mm.)

Ref	Kg	Mat	Sup/Finish Acabado	A	B	C	Thickn. Espesor	E-mark	Part	Lot
0282326	28	INOX		800	500	500	1.5			1
0282320	28.6	INOX		800	500	500	1.5			1
0282302	34.5	INOX		1000	500	500	1.5			1

Ergonomic Et Double Security Lock (key Et ring for padlock) | Optional gas springs or cable |
Metallic hinges and copper-plated steel screws | Sealing
Cierre Ergonómico Doble Seguridad (llave+anilla candado) | Opción amortiguador o cable |
Bisagras metálicas, tornillería acero cobreado | Estanqueidad
ECE-R73.01 Lateral Protection Devices

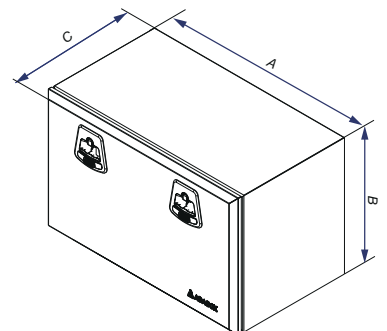

STEEL TOOL ADABOX / WERKZEUGKÄSTEN STAHL ADABOX / CAJÓN METÁLICO ADABOX



Black Galvanized / Galvanizado Negro (1,5 mm.)



- ✓ MATERIAL / MATERIAL:
 - Body-Cover / Cuerpo-Tapa: Galvanized Steel Dx51D-Z275 Black Powder Coated
- ✓ THICKNESS / ESPESOR:
 - Body / Cuerpo: 1.5 mm.
 - Cover / Tapa: 2 mm.
- ✓ HOMOLOGATION / HOMOLOGACIÓN: ECE-R73.01
- ✓ PRODUCTION PROCESS / PROCESO FABRICACIÓN: Continuous welding / Soldadura continua

Accessories Accesorios		Ref.	
●	Metallic hinge Metallscharnier Bisagra metálica	0298020	
●	Lock Verschluss Cierre	1203001	
●	Rubber seal Gummidichtung Junta de goma	0298004	
●	Steel Cable o Gas Spring Stahlkabel o Gasfeder Cable acero o Amortiguador	0298024 0298011	
	Brackets Halteung Soporte	0201498	



ADABOX Galvanized Steel Black Box (1,5 mm.)
ADABOX Werkzeugkasten Verzinkt Schwarz (1,5 mm.)
Cajón ADABOX Acero Galvanizado Negro (1,5 mm.)

Ref	Kg	Mat	Sup/Finish Acabado	Col	A	B	C	Thickn. Espesor	Emark	Part	Lot
0282152 NEW	22.5	STEEL	Galv	●	400	600	600	1.5			1
0282150	14.4	STEEL	Galv	●	500	350	400	1.5			1
0282151	19.1	STEEL	Galv	●	500	500	450	1.5			1
0282154	19.9	STEEL	Galv	●	600	400	500	1.5			1
0282155	20.03	STEEL	Galv	●	600	400	500	1.5			1
0280017 NEW	23.8	STEEL	Galv	●	600	400	500	1.5			1
0282156	23	STEEL	Galv	●	600	500	500	1.5			1
0282157 NEW	19.9	STEEL	Galv	●	600	600	600	1.5			1

ECE-R73.01 Lateral Protection Devices

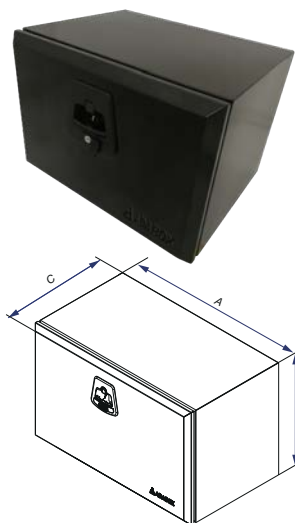

ADABOX Galvanized Steel Black Box (1,5 mm.)
ADABOX Werkzeugkasten Verzinkt Schwarz (1,5 mm.)
Cajón ADABOX Acero Galvanizado Negro (1,5 mm.)

Ref	Kg	Mat	Sup/Finish Acabado	Col	A	B	C	Thickn. Espesor	Emark	Part	Lot
0282158	28.3	STEEL	Galv	●	800	500	500	1.5			1
0282159	28.3	STEEL	Galv	●	800	500	500	1.5			1
0280015 NEW	33.6	STEEL	Galv	●	800	500	500	1.5			1
0282160 NEW	35	STEEL	Galv	●	800	600	600	1.5			1
0282162	33.8	STEEL	Galv	●	1000	500	500	1.5			1
0282163	33.8	STEEL	Galv	●	1000	500	500	1.5			1
0280016 NEW	40.7	STEEL	Galv	●	1000	500	500	1.5			1
0282161 NEW	41.5	STEEL	Galv	●	1000	600	600	1.5			1
0282164	38.1	STEEL	Galv	●	1200	500	500	1.5			1
0282165 NEW	38.1	STEEL	Galv	●	1200	500	500	1.5			1
0282167 NEW	48	STEEL	Galv	●	1200	600	600	1.5			1

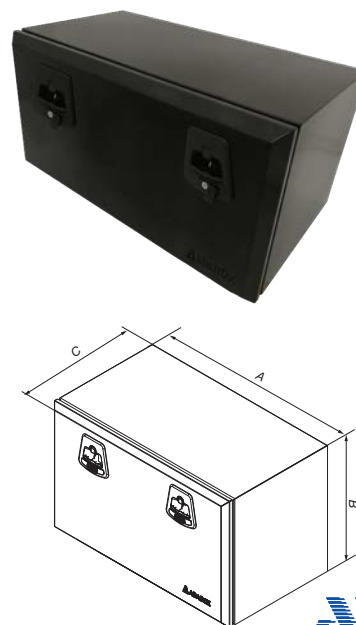

Ergonomic & Double Security Lock (key & ring for padlock) | Optional gas springs or cable | Metallic hinges and copper-plated steel screws | Sealing
Cierre Ergonómico Doble Seguridad (llave+anilla candado) | Opción amortiguador o cable | Bisagras metálicas, tornillería acero cobreado | Estanqueidad
ECE-R73.01 Lateral Protection Devices

BOXES AND TANKS / WERKZEUGKÄSTEN UND WASSERTANKS / CAJONES Y BIDONES



STEEL TOOL ADABOX / WERKZEUGKÄSTEN STAHL ADABOX / CAJÓN METÁLICO ADABOX

BOXES AND TANKS / WERKZEUGKÄSTEN UND WASSERTANKS / CAJONES Y BIDONES



Black Galvanized / Galvanizado Negro (1,5 mm.)
Inox Cover / Tapa Inox



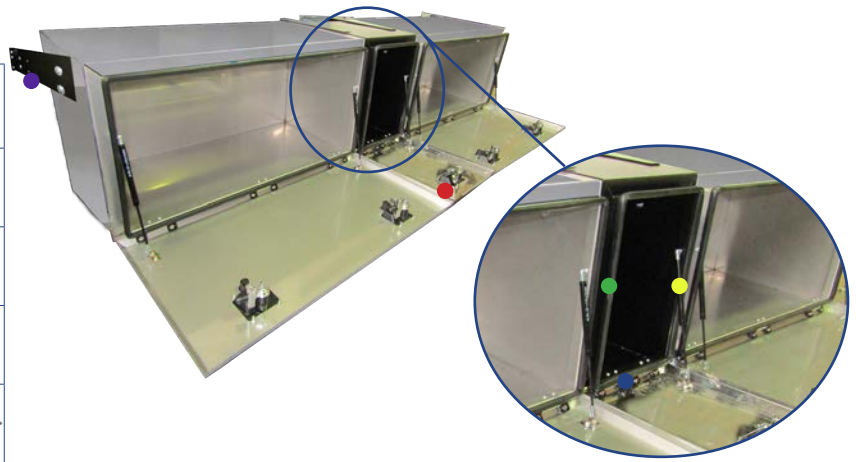

- ✓ MATERIAL / MATERIAL:
 - Body / Cuerpo: Galvanized Steel Dx51D-Z275 Black Powder Coated
 - Cover / Tapa: Stainless Steel AISI 304/X5CrNi1 8-10/1,4301
- ✓ THICKNESS / ESPESOR:
 - Body / Cuerpo: 1.5 mm.
 - Cover / Tapa: 2 mm.
- ✓ HOMOLOGATION / HOMOLOGACIÓN:  ECE-R73.01
- ✓ PRODUCTION PROCESS: / PROCESO FABRICACIÓN: Continuous welding / Soldadura continua

Accessories Accesorios	Ref.	
 Metallic hinge Metallscharnier Bisagra metálica	0298020	
 Lock Verschluss Cierre	1203001	
 Rubber seal Gummidichtung Junta de goma	0298004	
 Gas Spring Gasfeder Amortiguador	0298011	
 Brackets Halterung Soporte	0201498	



ADABOX Galvanized Steel Black Box (1,5 mm.) Matt Stainless Steel Cover
ADABOX Werkzeugkasten Verzinkt Schwarz (1,5 mm.) Deckel Edelstahl Matt
Cajón ADABOX Galv. Negro (1,5 mm.) Tapa Inox Mate

NEW



Ref	Kg	Mat	Sup/Finish Acabado	Col	A	B	C	Thickn. Espesor	Emark	Part	Lot
0282147	16.7	STEEL	Galv		360	500	500	1.5			1

Ergonomic & Double Security Lock (key & ring for padlock) | Optional gas springs or cable |
Metallic hinges |with Aerator | Sealing
Cierre Ergonómico Doble Seguridad (llave+anilla candado) | Opción amortiguador o cable |
Bisagras metálicas | con aireador | Estanqueidad

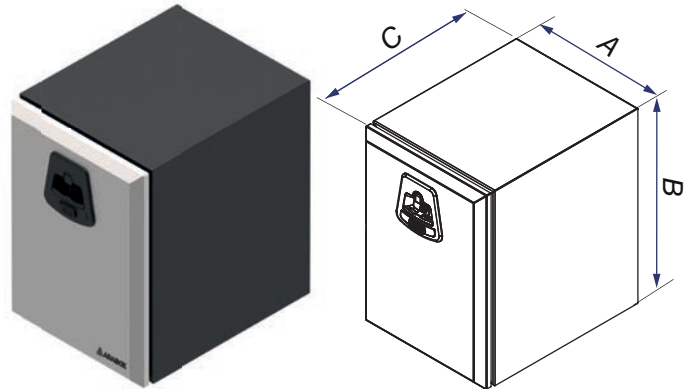
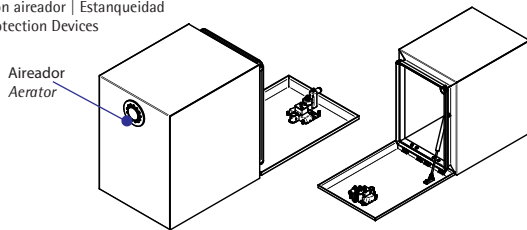
ECE-R73.01 Lateral Protection Devices



ADABOX Galvanized Steel Black Box (1,5 mm.) Open
ADABOX Werkzeugkasten Verzinkt Schwarz (1,5 mm.) Offen
Cajón ADABOX Acero Galvanizado Negro (1,5 mm.) Abierto

Ref	Kg	Mat	Sup/Finish Acabado	Col	A	B	C	Thickn. Espesor	Emark	Part	Lot
0282153	14	STEEL	Galv		360	500	470	1.5			1

Ergonomic & Double Security Lock (key & ring for padlock) | Optional gas springs or cable |
Metallic hinges and copper-plated steel screws | Sealing
Cierre Ergonómico Doble Seguridad (llave+anilla candado) | Opción amortiguador o cable |
Bisagras metálicas, tornillería acero cobreado | Estanqueidad

ECE-R73.01 Lateral Protection Devices

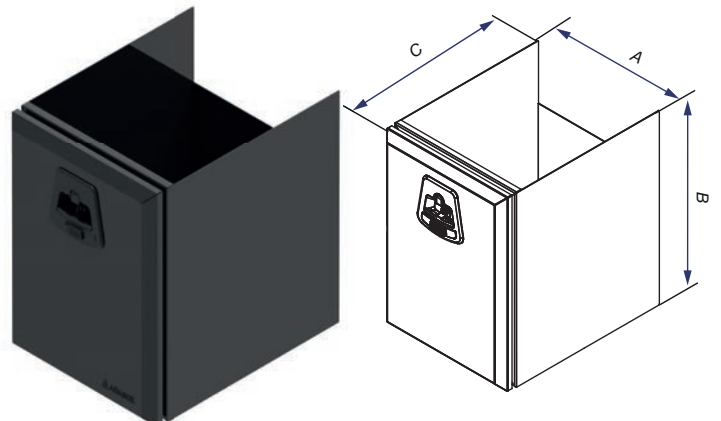
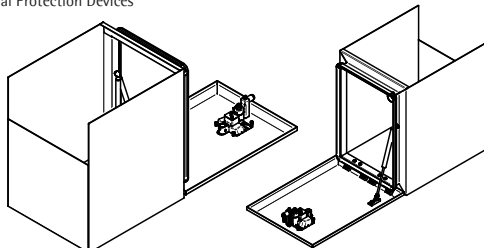

STEEL TOOL ADABOX / WERKZEUGKÄSTEN STAHL ADABOX / CAJÓN METÁLICO ADABOX



Polished Stainless Steel / *Inoxidable Brillo* (1,5 mm.)







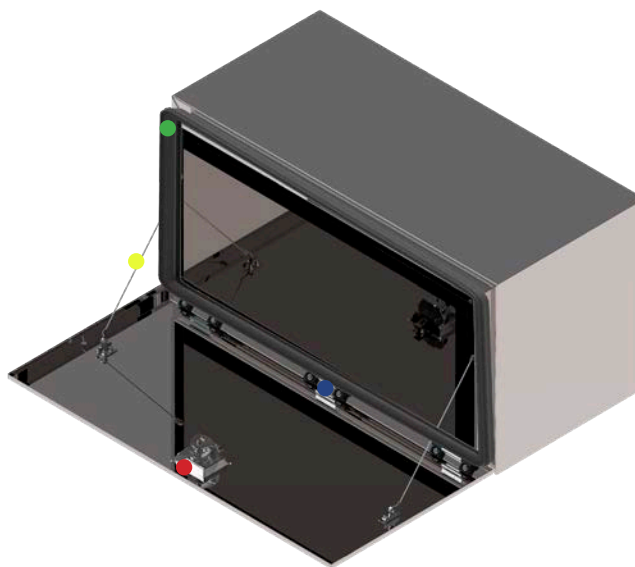













- ✓ MATERIAL / MATERIAL:
 - Body-Cover / *Cuerpo-Tapa*: Stainless Steel AISI 304/X5CrNi1 8-10/1,4301 2R/BA Bright
- ✓ THICKNESS / *ESPESOR*:
 - Body / *Cuerpo*: 1.5 mm.
 - Cover / *Tapa*: 2 mm.
- ✓ HOMOLOGATION / *HOMOLOGACIÓN*: ECE-R73.01 
- ✓ PRODUCTION PROCESS: / *PROCESO FABRICACIÓN*: Continuous welding / *Soldadura continua*

Accessories <i>Accesorios</i>	Ref.	
<ul style="list-style-type: none"> • Metallic hinge <i>Metallscharnier</i> <i>Bisagra metálica</i> 	0298020	
<ul style="list-style-type: none"> • Stainless Steel Lock <i>Edelsahl Verschluss</i> <i>Cierre de Acero Inoxidable</i> 	1203002 1203003	
<ul style="list-style-type: none"> • Rubber seal <i>Gummidichtung</i> <i>Junta de goma</i> 	0298004	
<ul style="list-style-type: none"> • Steel Cable o Gas Spring <i>Stahlkabel o Gasfeder</i> <i>Cable acero o Amortiguador</i> 	0298024 0298011	
<ul style="list-style-type: none"> • Brackets <i>Halterung</i> <i>Soporte</i> 	0201498	



ADABOX Bright Stainless Steel Box (1,5 mm.)
ADABOX Werkzeugkasten Edelstahl Poliert (1,5 mm.)
Cajón ADABOX Inox Liso Brillo (1,5 mm.)

Ref	Kg	Mat	Sup/Finish <i>Acabado</i>	A	B	C	Thickn. <i>Espesor</i>	Emark	Part	Lot
0282346	20.8	INOX		600	400	500	1.5			1
0282348 NEW	21	INOX		600	400	500	1.5			1
0282328	29.5	INOX		800	500	500	1.5			1
0282324 NEW	29.7	INOX		800	500	500	1.5			1
0282306	34.5	INOX		1000	500	500	1.5			1
0282308 NEW	34.7	INOX		1000	500	500	1.5			1

Stainless Steel Lock | Optional gas springs or cable | Metallic hinges and steel screws | Sealing
Cierre Acero Inoxidable | Opción amortiguador o cable | Bisagras metálicas, tornillería acero | Estanqueidad
ECE-R73.01 Lateral Protection Devices

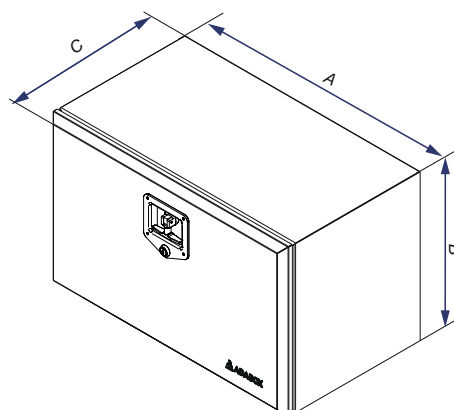

BOXES AND TANKS / WERKZEUGKÄSTEN UND WASSERTANKS / CAJONES Y BIDONES



STEEL TOOL ADABOX / WERKZEUGKÄSTEN STAHL ADABOX / CAJÓN METÁLICO ADABOX

BOXES AND TANKS / WERKZEUGKÄSTEN UND WASSERTANKS / CAJONES Y BIDONES



Black Galvanized / *Galvanizado Negro* (1,2 mm.)
Black Cover / *Tapa Negra*





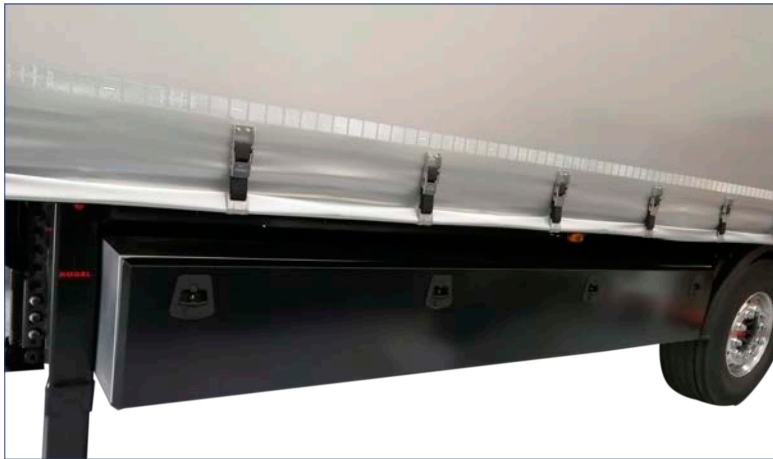

- ✓ MATERIAL / MATERIAL:
 - Body / *Cuerpo*: Galvanized Steel Dx51D-Z275
 - Cover / *Tapa*: Galvanized Steel Dx51D-Z275 Black Powder Coated
- ✓ THICKNESS / *ESPESOR*:
 - Body / *Cuerpo*: 1.2 mm.
 - Cover / *Tapa*: 2 mm.
- ✓ HOMOLOGATION / *HOMOLOGACIÓN*: ECE-R73.01 
- ✓ PRODUCTION PROCESS / *PROCESO FABRICACIÓN*: Continuous welding / *Soldadura continua*
- ✓ APPLICATION / *APLICACIÓN*: Special for sideboards / *Especial para tablas*

Accesorios Accessoires		Ref.	
	Metallic hinge <i>Metallscharnier</i> Bisagra metálica	0298022	
	Lock <i>Verschluss</i> Cierre	1203001	
	Rubber seal <i>Gummidichtung</i> Junta de goma	0298004	
	Chains <i>Ketten</i> Cadenas	0298044	
	Brackets <i>Halterung</i> Soporte	0201494	



ADABOX Galvanized Steel Box (1,2 mm.) Black Cover, for tables
ADABOX Werkzeugkasten Verzinkt (1,2 mm.) Deckel Schwarz, für Tische
Cajón para tablas ADABOX Galv. (1,2 mm.) Tapa Negra

Ref	Kg	Mat	Sup/Finish Acabado	A	B	C	Thickn. Espesor	E-mark	Lock Type Cierre	Lot
0282180	48	STEEL	Galv	2600	450	350	1.2			1
0282182	60	STEEL	Galv	3300	450	350	1.2			1

Ergonomic & Double Security Lock (key & ring for padlock) | Optional gas springs or cable |
Metallic hinges and copper-plated steel screws | Sealing
Cierre Ergonómico Doble Seguridad (llave+anillo candado) | Bisagras metálicas, tornillería acero cobreado | Estanqueidad

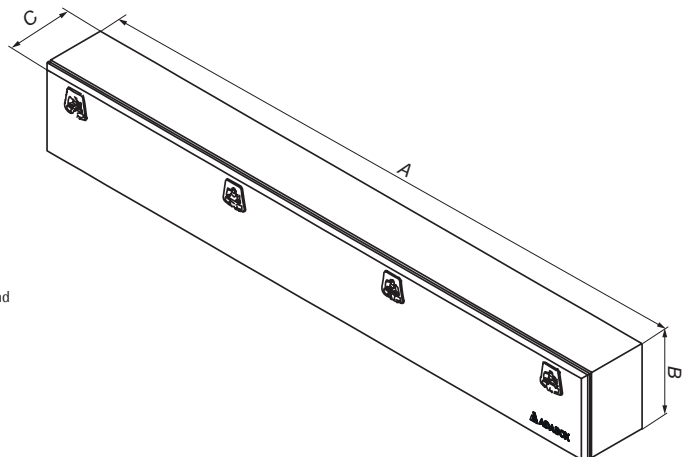

STEEL TOOL ADABOX / WERKZEUGKÄSTEN STAHL ADABOX / CAJÓN METÁLICO ADABOX

ADABOX **PALLETBOX**

Galvanized / Galvanizado (1,5 mm.)
White Cover / Tapa Blanca



- ✓ MATERIAL / MATERIAL:
 - Body / Cuerpo: Galvanized Steel Dx51D-Z275
 - Cover / Tapa: Galvanized Steel Dx51D-Z275 White Powder Coated RAL 9016
- ✓ THICKNESS / ESPESOR:
 - Body / Cuerpo: 1.5 mm.
 - Cover / Tapa: 2 mm.
- ✓ HOMOLOGATION / HOMOLOGACIÓN: ECE-R73.01
- ✓ DISASSEMBLED KIT / KIT DESMONTADO:

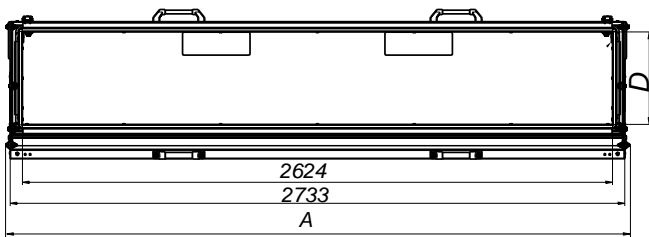
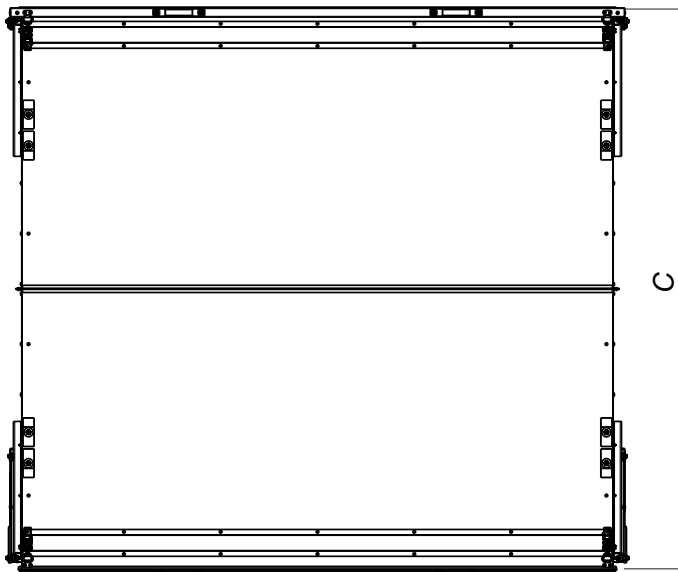

Accesorios Accessoires		Ref.	
●	Chassis Bracket 125x50x20 Klemmpratze 125x50x20 Fijación de Chasis 125x50x20	2001015	
●	Lock Verschluss Cierre	1203064	

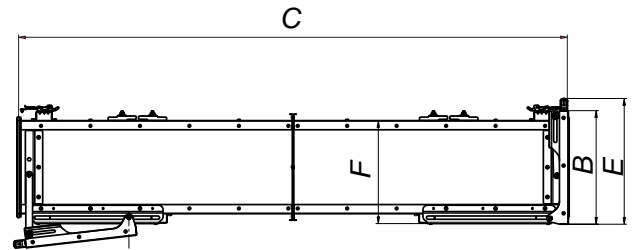

Galvanized Pallet Box ADABOX, White Door
Palettenstaukasten Feuerverzinkt ADABOX, Weiße Tür
Cajón Portapalets ADABOX Galvanizado, Tapa Blanca

Ref	Kg	Mat	Sup/Finish Acabado	Col	A	B	C	D	E	F	Thickn. Espesor	Emark	Article	Lot
1782113	310	STEEL	Galv	○	2753	495	2440	403	548	449	1.5		24EP	1
1782116	335	STEEL	Galv	○	2753	640	2440	548	693	594	1.5		30EP	1
1782114	343	STEEL	Galv	○	2753	685	2440	593	738	639	1.5		36EP	1

Galvanized steel body | White Cover | to be assembled | completely closed | Ergonomic Lock (ring for padlock) | Brackets includes
Cuerpo en Acero Cincado | Tapa Blanca | Completamente cerrado | Desmontado | Cierre Ergonómico Doble Seguridad (anilla candado) | Incluye Fijaciones
ECE-R73.01 Lateral Protection Devices



BOXES AND TANKS / WERKZEUGKÄSTEN UND WASSERTANKS / CAJONES Y BIDONES



STEEL TOOL ADABOX / WERKZEUGKÄSTEN STAHL ADABOX / CAJÓN METÁLICO ADABOX

BOXES AND TANKS / WERKZEUGKÄSTEN UND WASSERTANKS / CAJONES Y BIDONES

ADABOX Galvanized / Galvanizado



- ✓ MATERIAL / MATERIAL:
 - Body-Door / Cuerpo-Puerta: Galvanized Steel Dx51D-Z275 White Powder Coated RAL 9010
- ✓ THICKNESS / ESPESOR:
 - Body-Door / Cuerpo-Puerta: 2 mm.
- ✓ PRODUCTION PROCESS / PROCESO FABRICACIÓN:
 - Continuous welding / Soldadura continua
- ✓ APPLICATION / APLICACIÓN:
 - Retrocab Storage Box / Cajón Retrocabina

Accesorios Accessoires		Ref.	
●	Metallic hinge Metallscharnier Bisagra metálica	0298020	
●	Lock Verschluss Cierre	1203001	
●	Rubber seal Gummidichtung Junta de goma	0298004	
●	Gas Spring Gasfeder Amortiguador	0298011	

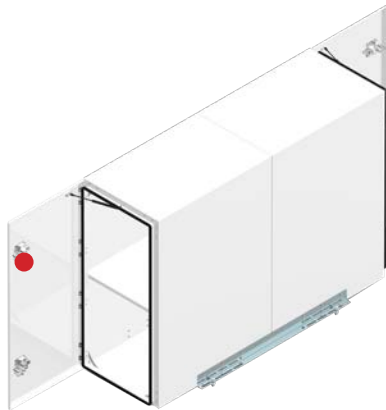

Retrocab Storage Box ADABOX Galvanized, White Cover
Hinterfahrerhauskasten ADABOX, Galvanisiert, mit Deckel Weiss
Cajón ADABOX Retrocabina Galvanizado, Tapa Blanca



Ref	Kg	Mat	Sup/Finish Acabado	Col	A	B	C	D	Thickn. Espesor	Part	Lot
0282412	111	STEEL	Galv	○	600	800	1900	399	2		1
0282418	120	STEEL	Galv	○	600	900	2000	449	2		1
0282401	144	STEEL	Galv	○	600	1300	1900	649	2		1
0282420	148	STEEL	Galv	○	600	1300	2000	649	2		1
0282416	153	STEEL	Galv	○	600	1450	1900	724	2		1
0282422	158	STEEL	Galv	○	600	1450	2000	724	2		1
0282424	170	STEEL	Galv	○	800	1300	2000	648	2		1
0282426	184	STEEL	Galv	○	800	1500	2000	748	2		1

RAL 9010 color | Each door with 1 gas spring and two locks | Interior: shelf and corner reinforcement plate |
Brackets Set included
Color RAL 9010 | Cada puerta con 1 amortiguador y dos cierres | Interior: balda y pletina de refuerzo en esquinas |
Incluye Kit de Soportes

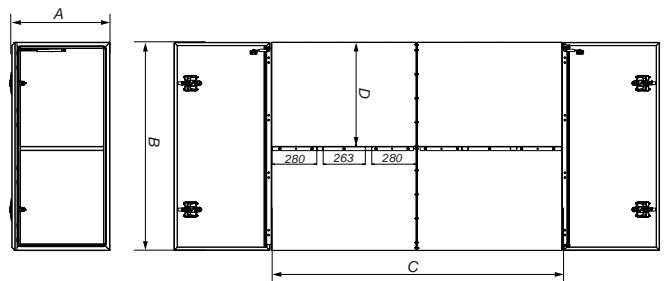

STEEL TOOL ADABOX / WERKZEUGKÄSTEN STAHL ADABOX / CAJÓN METÁLICO ADABOX



Galvanized / Galvanizado



- ✓ MATERIAL / MATERIAL:
 - Body / Cuerpo: Galvanized Steel Dx51D-Z275
 - Door / Puerta: Galvanized Steel Dx51D-Z275
- ✓ THICKNESS / ESPESOR:
 - Body / Cuerpo: 2 mm.
 - Door / Puerta: 2 mm.

Accesorios Accessoires		Ref.	
●	Chassis Set Bracket Klemmpratze Set Kit de Fijación de Chasis	0298028	
●	Lock Verschluss Cierre	1203064	
●	Hinge Scharniere Bisagra	0298026	

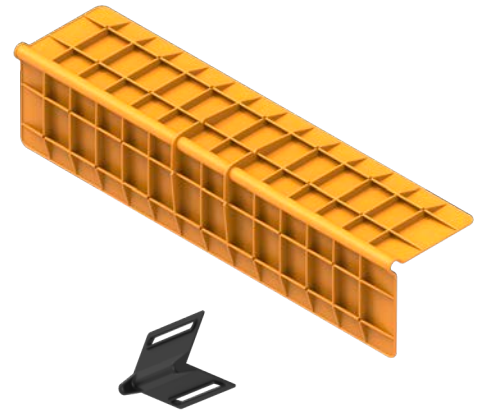
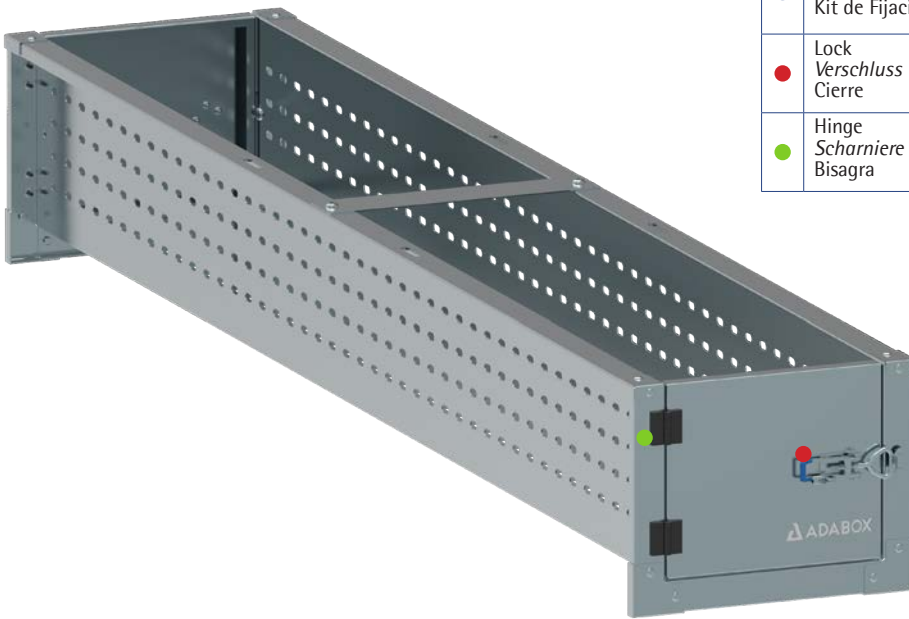

ADABOX Metallic Open Box for Corner Protector
ADABOX Metall Kiste für Kantenschutzwinkel, offen
Cajón Metálico ADABOX para Cantoneras, Abierto

Ref	Kg	Mat	Sup/Finish Acabado	Thickn. Espesor	Lot
0292105	50	STEEL	Galv	2	1

Bracket set included
Incluye Kit de fijaciones

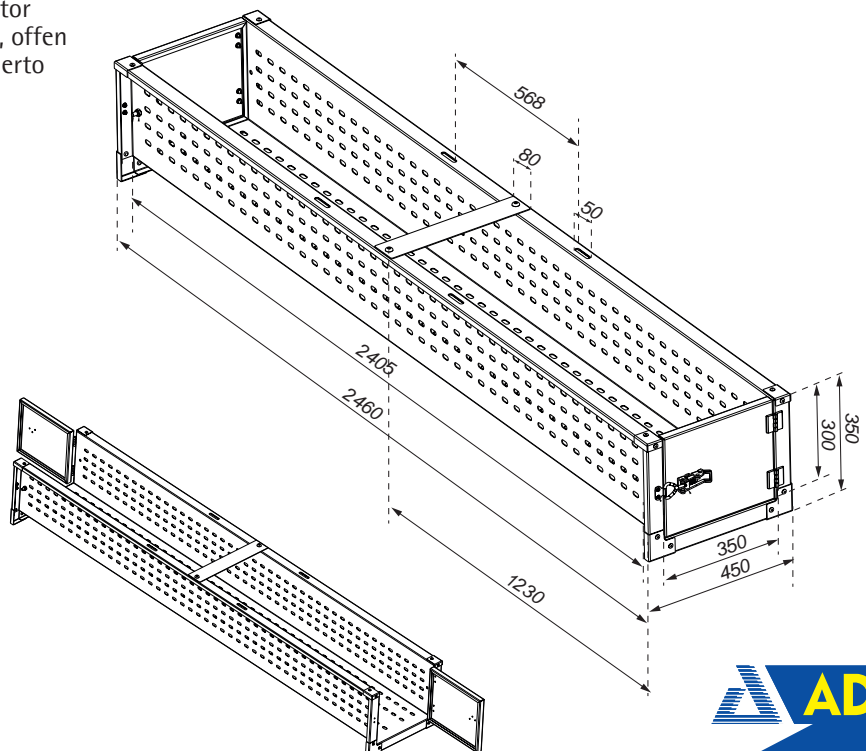

BOXES AND TANKS / WERKZEUGKÄSTEN UND WASSERTANKS / CAJONES Y BIDONES



STEEL TOOL ADABOX / WERKZEUGKÄSTEN STAHL ADABOX / CAJÓN METÁLICO ADABOX

ADABOX Galvanized / Galvanizado (2 mm.)

BOXES AND TANKS / WERKZEUGKÄSTEN UND WASSERTANKS / CAJONES Y BIDONES



- ✓ MATERIAL / MATERIAL:
 - Body / Cuerpo: Galvanized Steel Dx51D-Z275
- ✓ THICKNESS / ESPESOR:
 - Body / Cuerpo: 2 mm.
- ✓ PRODUCTION PROCESS / PROCESO FABRICACIÓN:
 - Continuous welding / Soldadura continua

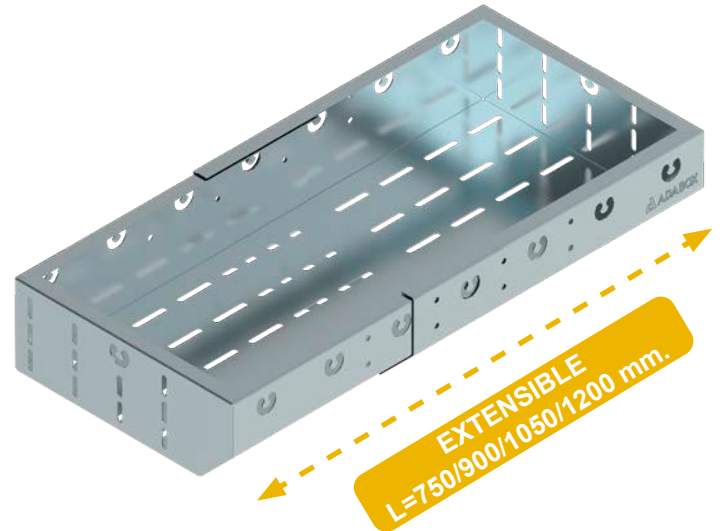
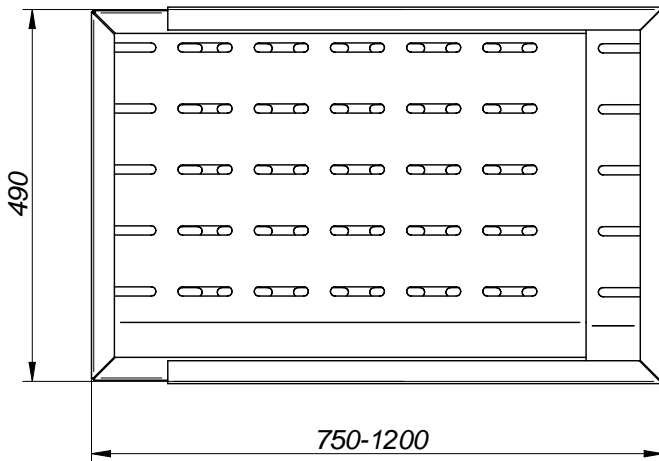
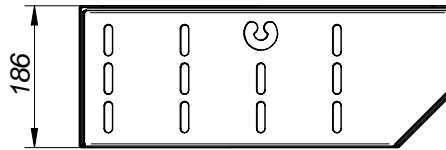
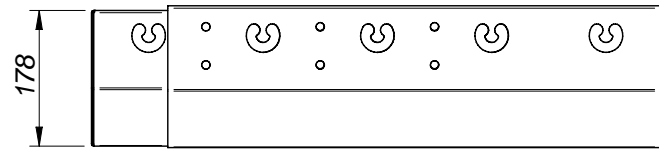

ADABOX Galvanized Steel Box for Cargo Equipment, Adjustable
ADABOX Verzinkter Stahlkasten für Cargo, verstellbar
Cajón Galv. ADABOX para Redes de Seguridad, Regulable

NEW

Ref	Kg	Mat	Sup/Finish Acabado	Thickn. Espesor	Lot
0292106	25	STEEL	Galv	2	1



STEEL TOOL ADABOX / WERKZEUGKÄSTEN STAHL ADABOX / CAJÓN METÁLICO ADABOX



ADABOX Black Galvanized / Galvanizado Negro (1,5 mm.)



- ✓ MATERIAL / MATERIAL:
 - Body-Cover / Cuerpo-Tapa: Galvanized Steel Dx51D-Z275 Black Powder Coated
- ✓ THICKNESS / ESPESOR:
 - Body / Cuerpo: 1.5 mm.
 - Cover / Tapa: 2 mm.
- ✓ HOMOLOGATION / HOMOLOGACIÓN: ECE-R73.01 
- ✓ PRODUCTION PROCESS / PROCESO FABRICACIÓN: Continuous welding / Soldadura continua

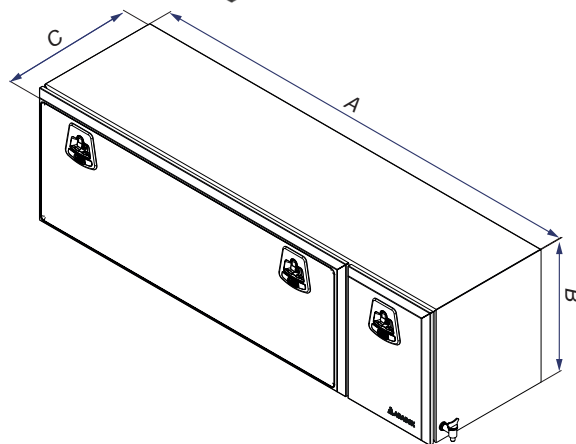
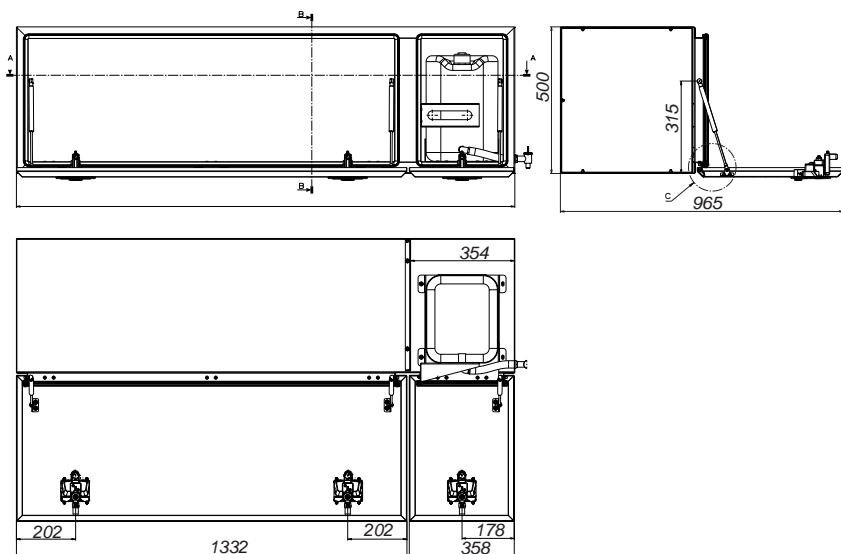
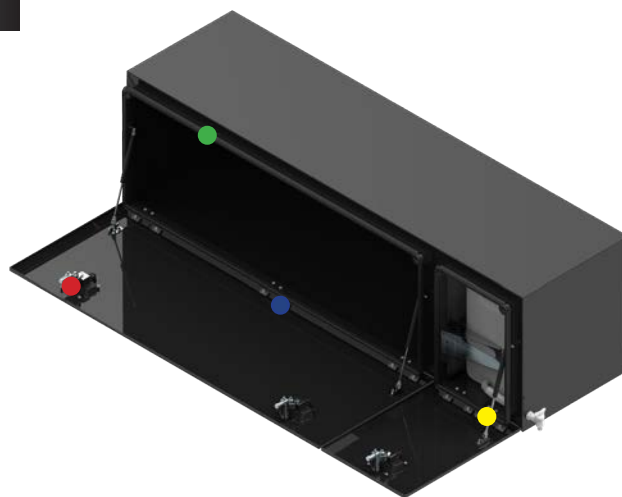

Accesorios Accessoires		Ref.	
	Metallic hinge Metallscharnier Bisagra metálica	0298020	
	Lock Verschluss Cierre	1203001	
	Rubber seal Gummidichtung Junta de goma	0298004	
	Gas Spring Gasfeder Amortiguador	0298011	



BOXES AND TANKS / WERKZEUGKÄSTEN UND WASSERTANKS / CAJONES Y BIDONES

Box with Tank ADABOX, Black Galvanized Steel
ADABOX Werkzeugkasten mit Tank, Verzinkt Schwarz (1,5 mm.)
Cajón con Bidón ADABOX Galvanizado Negro (1,5 mm.)

NEW

Ref	Kg	Mat	A	B	C	Sup/Finish Acabado	Col	Thickn. Espesor	E-mark	Part	Lot
0290006	40	STEEL	1700	500	500	Galv		1.5			12

ECE-R73.01 Lateral Protection Devices

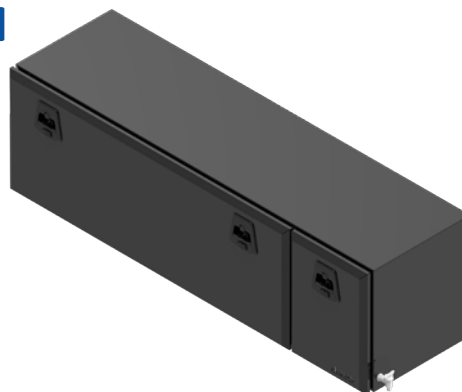

STEEL TOOL ADABOX / WERKZEUGKÄSTEN STAHL ADABOX / CAJÓN METÁLICO ADABOX

ADABOX White Galvanized / Galvanizado Blanco (1,5 mm.)



- ✓ MATERIAL / MATERIAL:
 - Body-Cover / Cuerpo-Tapa: Galvanized Steel Dx51D-Z275 White Powder Coated RAL9010
- ✓ THICKNESS / ESPESOR:
 - Body / Cuerpo: 1.5 mm.
 - Cover / Tapa: 2 mm.
- ✓ HOMOLOGATION / HOMOLOGACIÓN:  ECE-R73.01
- ✓ PRODUCTION PROCESS / PROCESO FABRICACIÓN: Continuous welding / Soldadura continua

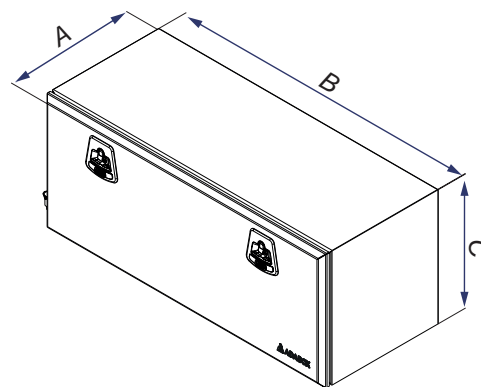
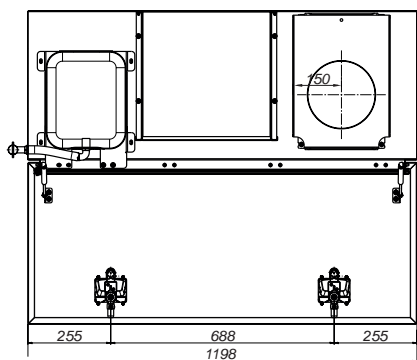
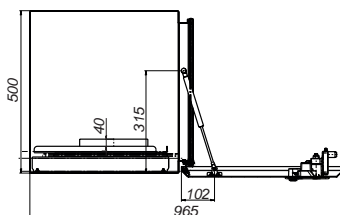
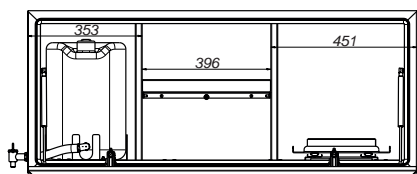
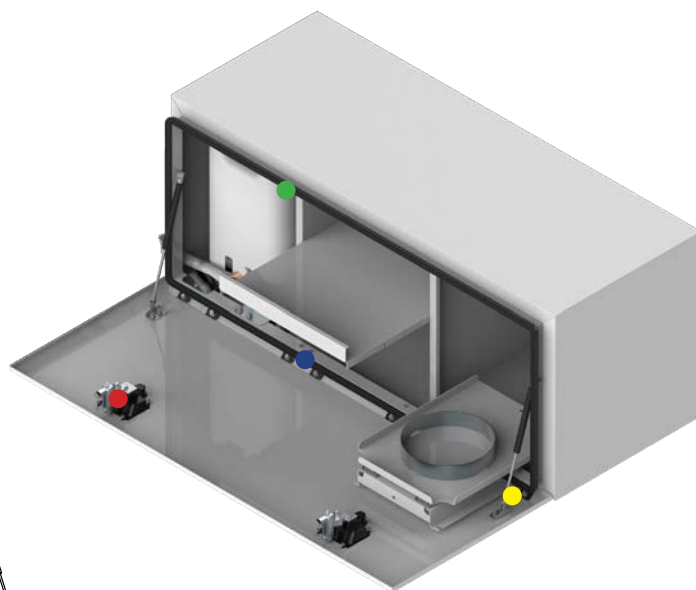

BOXES AND TANKS / WERKZEUGKÄSTEN UND WASSERTANKS / CAJONES Y BIDONES

Accesorios Accessoires	Ref.	
<ul style="list-style-type: none"> ● Metallic hinge Metallscharnier Bisagra metálica 	0298020	
<ul style="list-style-type: none"> ● Lock Verschluss Cierre 	1203001	
<ul style="list-style-type: none"> ● Rubber seal Gummidichtung Junta de goma 	0298004	
<ul style="list-style-type: none"> ● Gas Spring Gasfeder Amortiguador 	0298011	



Box with Tank/Stove Shelf ADABOX
ADABOX Werkzeugkasten mit Tank und Küchenloch
Cajón ADABOX con Bidón y Bandeja Hornillo

NEW

Ref	Kg	Mat	A	B	C	Sup/Finish Acabado	Col	Thickn. Espesor	Emark	Part	Lot
0290036	47.5	STEEL	1200	500	500	Galv		1.5			12

RAL 9010 color | Each door with 1 gas spring and two locks | Interior: shelf, 20L. tank and stove hole
Color RAL 9010 | Cada puerta con 1 amortiguador y dos cierres | Interior: balda, bidón 20L, bandeja hornillo
ECE-R73.01 Lateral Protection Devices

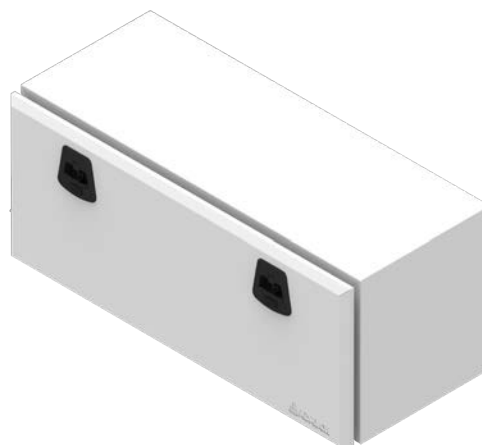

STEEL TOOL ADABOX / WERKZEUGKÄSTEN STAHL ADABOX / CAJÓN METÁLICO ADABOX

Transpallet Box (1,5 mm.) with Ramp in Aluminium
 Hubwagenkasten (1,5 mm.) mit Rampe aus Aluminium
 Cajón Transpaleta (1,5 mm.) con Rampa de Aluminio

Ref	Kg	Mat	Sup/Finish Acabado	Col	A	B	C	Thickn. Espesor	E-mark	Part	Lot
0282430	60	STEEL	Zn	●	670	650	1600	1.5	E57		1
0282432	70	STEEL	Zn	●	820	650	1600	1.5	E57		1

Black epoxy powder | handle and hinges in nylon | TIG / laser welding | Pullout ramp in aluminium tread plate | Anti-scratch roller-conveyor
 Pintado epoxy negro | Cierre y bisagras en nylon | Soldadura TIG | Rampa extraíble de aluminio almadrado | Plataforma con rodillos antiarañazos
 ECE-R73.01 Lateral Protection Devices



BOXES AND TANKS / WERKZEUGKÄSTEN UND WASSERTANKS / CAJONES Y BIDONES



PLASTIC line



JUST



WELVET



ARKA



FLINK

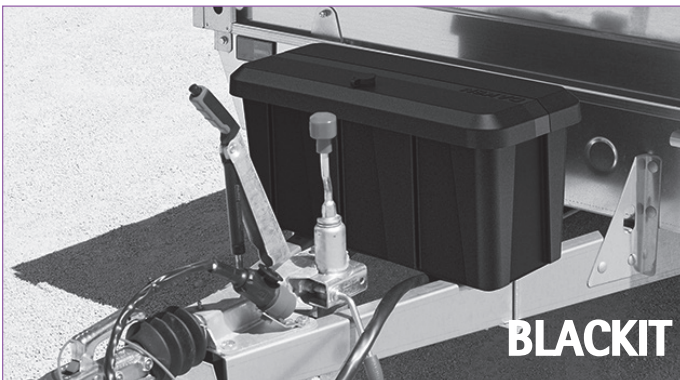

BLACKIT

✓ MATERIAL / MATERIAL:

- Body-Cover / Cuerpo-Tapa: Polypropylene / Polipropileno
- Lock / Cierre: Nylon

✓ PRODUCTION PROCESS / PROCESO FABRICACIÓN:

Injection molding / Moldeo por inyección

✓ THERMAL RESISTANCE / RESISTENCIA TÉRMICA:

from -20°C to + 70°C

✓ HOMOLOGATION / HOMOLOGACIÓN:

ECE-R73.01

Lateral Protection Device / Sistema de Protección Lateral

Plastic Box / Cajón Plástico

- Reinforced structure to ensure solidity and durability. *Nervios reforzados para garantizar solidez y resistencia.*
- Cylinder lock to ensure maximum security. *Cierre con cerradura para mayor seguridad.*
- Internal EPDM seal against water and dust ingress (IP59K, TÜV). *Estanqueidad al agua y polvo garantizada por la junta de EPDM (IP59K, TÜV).*



OPCIONAL: PERSONALIZACIÓN LOGO

DISASSEMBLED BOXES / CAJONES DESMONTADOS

✓ SAVING WAREHOUSE SPACE
AHORRO ESPACIO ALMACÉN

✓ QUICK ASSEMBLY
MONTAJE RÁPIDO



Etiqueta personalizado 12x4 cm.
étiquette personnalisée 12x4 cm.



Ref.	Peso (Kg.)	AxBxC (mm.)	Cap. (Kg.)	Cap. (l.)	BRACKETS / HALTERUNG / SOPORTES						
					Vertical	Horizontal					Hor. Vert.
					0201481	0201483	0201470	0201471	0201474	0201475	0201485
0201445	2,8	400x350x300	30	21	✓	✗	✓	✓	✓	✓	✓
0201441	3	500x350x300	30	30,5	✓	✗	✓	✗	✓	✗	✓
0201443	3,3	500x350x400	35	41,5	✓	✗	✓	✗	✓	✗	✓
0201442	4,9	600x415x460	45	74	✓	✓	✗	✓	✗	✓	✗
0201453	4,5	750x350x300	45	40	✓	✗	✓	✗	✓	✗	✓
0201454	5,2	750x350x450	45	74,5	✓	✓	✗	✓	✗	✓	✗
0201457	7,8	826x500x470	50	127	✓	✓	✗	✓	✗	✓	✗
0201461	5,4	900x367x300	50	57,5	✓	✗	✓	✗	✓	✗	✗
0201462	6,6	900x367x450	50	90	✓	✗	✗	✓	✗	✓	✗
0201464	9,9	1020x500x460	60	153	✓	✗	✗	✓	✗	✓	✗
0201444	3	410x348x340	40	28,5	✓	✗	✓	✗	✓	✗	✗
0201446	5	480x400x400	50	39,5	✓	✗	✓	✗	✓	✗	✗
0201450	8	630x450x480	60	78,5	✓	✓	✗	✓	✗	✓	✗
0201456	10,5	830x500x470	65	120	✓	✓	✗	✓	✗	✓	✗
0201458	13	1030x500x480	70	155	✓	✓	✗	✓	✗	✓	✗
0201451	7,6	655x450x470	80	74	✓	✗	✗	✗	✗	✗	✗
0201452	6,5	685x500x500	50	109	✓	✓	✗	✓	✗	✓	✗
0201455	10,7	858x522x500	80	134	✓	✗	✗	✓	✗	✓	✗
0201459	13,2	1062x522x500	80	169	✓	✓	✗	✓	✗	✓	✗
0201460	15	1250x524x500	115	203	✓	✗	✗	✓	✗	✓	✗
0201430	5,60	660x515x460	50	92	✓	✗	✗	✓	✗	✓	✗
0201412	2,30	550x255x310	20	24	✗	✗	✗	✓	✗	✓	✗
0201414	2,20	555x255x310	20	24	✗	✗	✗	✗	✗	✗	✗

JUST

WELVET

ARKA

FLINK

BLACKIT



Ref.	Box Dimensions Medidas Cajón	Body Cuerpo	Cover Tapa	Box TO BE ASSEMBLED (Body+Cover) Cajón DESMONTADO (Cuerpo+Tapa)		Box ASSEMBLED Cajón MONTADO		Model Modelo
				WxLxH Pallet WxLxH Pallet	Quantity Cantidad	WxLxH Pallet WxLxH Pallet	Quantity Cantidad	
				0201445	400x350x300	0201548	0201549	
0201443	500x350x400	0201550	0201551	102x109x257 cm.	48	102x109x271 cm.	36	JUST
0201442	600x415x460	0201560	0201561	105x131x264 cm.	40	105x131x251 cm.	25	JUST
0201451	655x450x470	0201564	0201565	93x131x260 cm.	30	94x133x260 cm.	20	ARKA
0201430	660x515x460	0201566	0201567	116x106x220 cm.	32	116x106x220 cm.	20	FLINK
0201452	685x500x500	0201568	0201569	104x140x256 cm.	28	104x122x258 cm.	16	ARKA
0201454	750x350x450	0201570	0201571	80x108x248 cm.	28	80x108x249 cm.	15	JUST
0201457	826x500x470	0201584	0201585	85x105x245 cm.	16	85x105x258 cm.	10	JUST
0201455	858x522x500	0201580	0201581	87x107x250 cm.	14	96x106x220 cm.	8	ARKA
0201462	900x367x450	0201590	0201591	91x115x246 cm.	24	91x120x250 cm.	15	JUST
0201464	1020x500x460	0201596	0201597	116x106x220 cm.	16	116x106x220 cm.	10	JUST
0201459	1062x522x500	0201594	0201595	91x115x246 cm.	24	116x106x220 cm.	8	ARKA
0201460	1250x524x500	0201598	0201599	106x126x228 cm.	14	106x126x220 cm.	8	ARKA

Plastic Tool Box 1020x500x460 JUST
 Kunststoff-Werkzeugkasten 1020x500x460 JUST
 Cajón Herramientas Plástico 1020x500x460 JUST

NEW

Ref	Kg	Mat	Col	Cap.Kg	Cap.L	Emark	Article	Lot
0201464	9.9	PP	●	60	153	E11	Box Cajón Montado	1
0201596	7.43	PP	●	60	153		Body Box Cuerpo	1
0201597	2.48	PP	●				Cover Box Tapa	1

Injection molding | Reinforcement ribs (stability/durability) | TPE seal against water/dust ingress |
 Resistant (UV, flammability, oils, temperatures)
 Moldeo (inyección) | Nervaduras reforzadas (solidez/resistencia) | Estanqueidad agua/polvo (Junta TPE) |
 Resistente (UV, fuego, aceites, temperaturas)
 ECE Regulation 73.01 | Lateral protection (VCA Homologation)

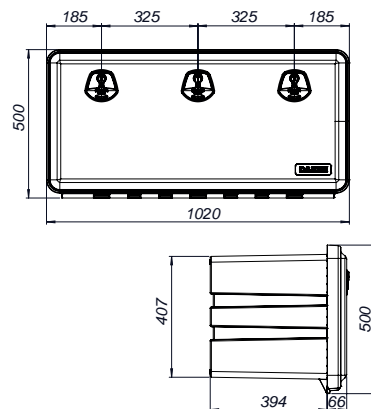

Plastic Tool Box 500x350x300 JUST
 Kunststoff-Werkzeugkasten 500x350x300 JUST
 Cajón Herramientas Plástico 500x350x300 JUST

Ref	Kg	Mat	Col	Cap.Kg	Cap.L	Emark	Article	Lot
0201441	3	PP	●	30	30.5	E11	Box Cajón Montado	1

Injection molding | Reinforcement ribs (stability/durability) | TPE seal against water/dust ingress |
 Resistant (UV, flammability, oils, temperatures)
 Moldeo (inyección) | Nervaduras reforzadas (solidez/resistencia) | Estanqueidad agua/polvo (Junta TPE) |
 Resistente (UV, fuego, aceites, temperaturas)
 ECE Regulation 73.01 | Lateral protection (VCA Homologation)

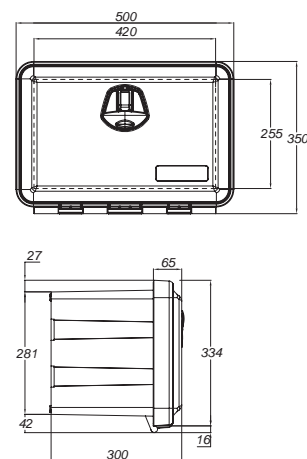

Plastic Tool Box 500x350x400 JUST
 Kunststoff-Werkzeugkasten 500x350x400 JUST
 Cajón Herramientas Plástico 500x350x400 JUST

Ref	Kg	Mat	Col	Cap.Kg	Cap.L	Emark	Article	Lot
0201443	3.3	PP	●	35	41.5	E11	Box Cajón Montado	1
0201550	2.5	PP	●	35	41.5		Body Box Cuerpo	1
0201551	0.85	PP	●				Cover Box Tapa	1

Injection molding | Reinforcement ribs (stability/durability) | TPE seal against water/dust ingress |
 Resistant (UV, flammability, oils, temperatures)
 Moldeo (inyección) | Nervaduras reforzadas (solidez/resistencia) | Estanqueidad agua/polvo (Junta TPE) |
 Resistente (UV, fuego, aceites, temperaturas)
 ECE Regulation 73.01 | Lateral protection (VCA Homologation)

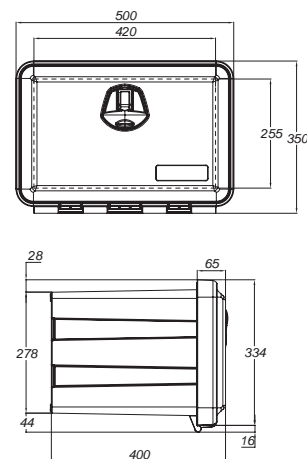

Plastic Tool Box 600x415x470 JUST
 Kunststoff-Werkzeugkasten 600x415x470 JUST
 Cajón Herramientas Plástico 600x415x470 JUST

Ref	Kg	Mat	Col	Cap.Kg	Cap.L	Emark	Article	Lot
0201442	4.9	PP	●	45	74	E11	Box Cajón Montado	1
0201560	3.8	PP	●	45	74		Body Box Cuerpo	1
0201561	1.1	PP	●				Cover Box Tapa	1

Injection molding | Reinforcement ribs (stability/durability) | TPE seal against water/dust ingress |
 Resistant (UV, flammability, oils, temperatures)
 Moldeo (inyección) | Nervaduras reforzadas (solidez/resistencia) | Estanqueidad agua/polvo (Junta TPE) |
 Resistente (UV, fuego, aceites, temperaturas)
 ECE Regulation 73.01 | Lateral protection (VCA Homologation)

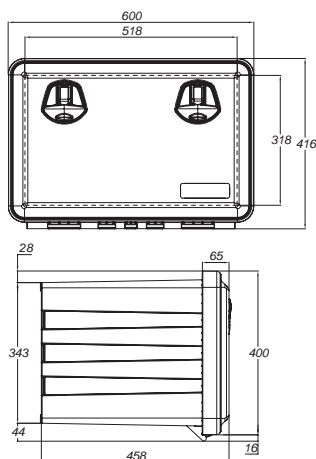

Plastic Tool Box 750x350x300 JUST
Kunststoff-Werkzeugkasten 750x350x300 JUST
Cajón Herramientas Plástico 750x350x300 JUST

Ref	Kg	Mat	Col	Cap.Kg	Cap.L	Emark	Article	Lot
0201453	4.5	PP	●	45	74.5	E11	Box Cajón Montado	1

Injection molding | Reinforcement ribs (stability/durability) | TPE seal against water/dust ingress | Resistant (UV, flammability, oils, temperatures)
 Moldeo (inyección) | Nervaduras reforzadas (solidez/resistencia) | Estanqueidad agua/polvo (Junta TPE) | Resistente (UV, fuego, aceites, temperaturas)
 ECE Regulation 73.01 | Lateral protection (VCA Homologation)

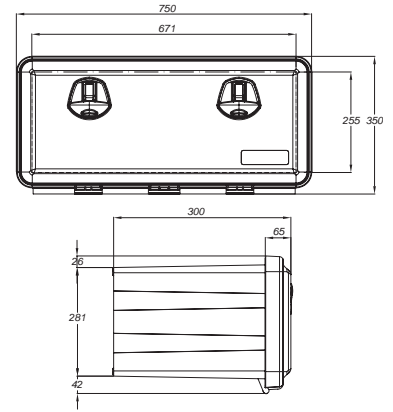

Plastic Tool Box 750x350x450 JUST
Kunststoff-Werkzeugkasten 750x350x450 JUST
Cajón Herramientas Plástico 750x350x450 JUST

Ref	Kg	Mat	Col	Cap.Kg	Cap.L	Emark	Article	Lot
0201454	5	PP	●	45	74.5	E11	Box	1
0201570	3.5	PP	●	45	74.5		Cajón Montado Body Box Cuerpo	1
0201571	1.7	PP	●				Cover Box Tapa	1

Injection molding | Reinforcement ribs (stability/durability) | TPE seal against water/dust ingress | Resistant (UV, flammability, oils, temperatures)
 Moldeo (inyección) | Nervaduras reforzadas (solidez/resistencia) | Estanqueidad agua/polvo (Junta TPE) | Resistente (UV, fuego, aceites, temperaturas)
 ECE Regulation 73.01 | Lateral protection (VCA Homologation)

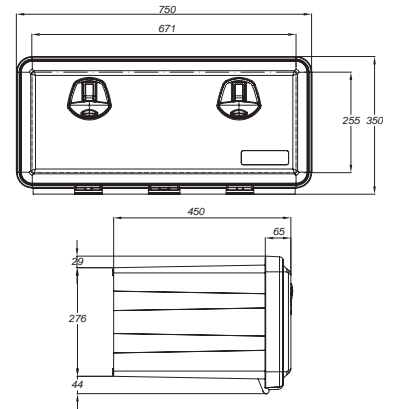

Plastic Tool Box 826x500x470 JUST
Kunststoff-Werkzeugkasten 826x500x470 JUST
Cajón Herramientas Plástico 826x500x470 JUST

Ref	Kg	Mat	Col	Cap.Kg	Cap.L	Emark	Article	Lot
0201457	7.83	PP	●	50	127	E11	Box	1
0201584	5.5	PP	●	50	127		Cajón Montado Body Box Cuerpo	1
0201585	2.3	PP	●				Cover Box Tapa	1

Injection molding | Reinforcement ribs (stability/durability) | TPE seal against water/dust ingress | Resistant (UV, flammability, oils, temperatures)
 Moldeo (inyección) | Nervaduras reforzadas (solidez/resistencia) | Estanqueidad agua/polvo (Junta TPE) | Resistente (UV, fuego, aceites, temperaturas)
 ECE Regulation 73.01 | Lateral protection (VCA Homologation)

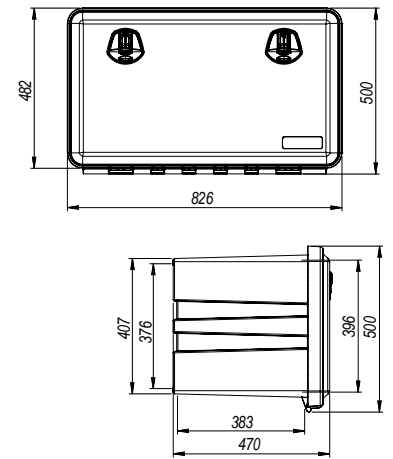

Plastic Tool Box 900x367x300 JUST
Kunststoff-Werkzeugkasten 900x367x300 JUST
Cajón Herramientas Plástico 900x367x300 JUST

Ref	Kg	Mat	Col	Cap.Kg	Cap.L	Emark	Article	Lot
0201461	5.4	PP	●	50	57.5	E11	Box Cajón Montado	1

Injection molding | Reinforcement ribs (stability/durability) | TPE seal against water/dust ingress | Resistant (UV, flammability, oils, temperatures)
 Moldeo (inyección) | Nervaduras reforzadas (solidez/resistencia) | Estanqueidad agua/polvo (Junta TPE) | Resistente (UV, fuego, aceites, temperaturas)
 ECE Regulation 73.01 | Lateral protection (VCA Homologation)

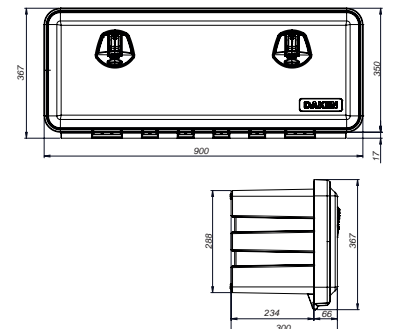

Plastic Tool Box 900x367x450 JUST
 Kunststoff-Werkzeugkasten 900x367x450 JUST
 Cajón Herramientas Plástico 900x367x450 JUST

Ref	Kg	Mat	Col	Cap.Kg	Cap.L	Emark	Article	Lot
0201462	6.6	PP	●	50	90	E11	Box Cajón Montado	1
0201590	3.4	PP	●	50	90		Body Box Cuerpo	1
0201591	2	PP	●				Cover Box Tapa	1

Injection molding | Reinforcement ribs (stability/durability) | TPE seal against water/dust ingress |
 Resistant (UV, flammability, oils, temperatures)
 Moldeo (inyección) | Nervaduras reforzadas (solidez/resistencia) | Estanqueidad agua/polvo (Junta TPE) |
 Resistente (UV, fuego, aceites, temperaturas)
 ECE Regulation 73.01 | Lateral protection (VCA Homologation)

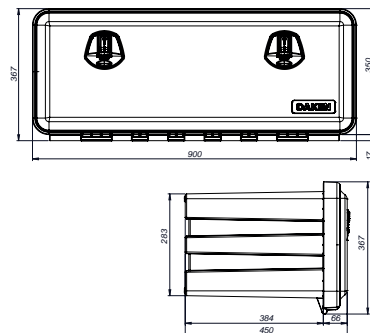

Plastic Tool Box 400x350x300 JUST
 Kunststoff-Werkzeugkasten 400x350x300 JUST
 Cajón Herramientas Plástico 400x350x300 JUST

NEW

Ref	Kg	Mat	Col	Cap.Kg	Cap.L	Emark	Article	Lot
0201445	2.8	PP	●	30	21	E11	Box Cajón Montado	1
0201548	1	PP	●	30	21		Body Box Cuerpo	1
0201549	1.8	PP	●				Cover Box Tapa	1

Injection molding | Smooth interior surface | Reinforced structure | PVC seal against water/dust ingress |
 Resistant (UV, flammability, oils, temperatures)
 Moldeo (inyección) | Superficie int. lisa | Estructura reforzada | Estanqueidad agua/polvo (Junta PVC) |
 Resistente (UV, fuego, aceites, temperaturas)
 ECE Regulation 73.01 | Lateral protection (VCA Homologation) | TÜV RHEINLAND Certification (IP59K)

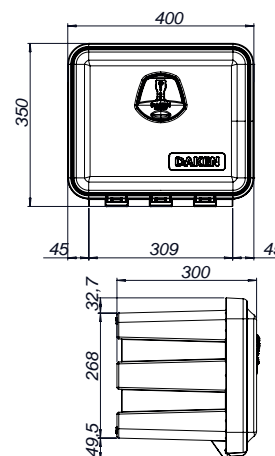

Plastic Tool Box 410x348x340 WELVET
 Kunststoff-Werkzeugkasten 410x348x340 WELVET
 Cajón Herramientas Plástico 410x348x340 WELVET

Ref	Kg	Mat	Col	Cap.Kg	Cap.L	Emark	Article	Lot
0201444	3	PP	●	40	28.5	E11	Box Cajón Montado	1

Injection molding | Smooth interior surface | Reinforced structure | PVC seal against water/dust ingress |
 Resistant (UV, flammability, oils, temperatures)
 Moldeo (inyección) | Superficie int. lisa | Estructura reforzada | Estanqueidad agua/polvo (Junta PVC) |
 Resistente (UV, fuego, aceites, temperaturas)
 ECE Regulation 73.01 | Lateral protection (VCA Homologation) | TÜV RHEINLAND Certification (IP59K)

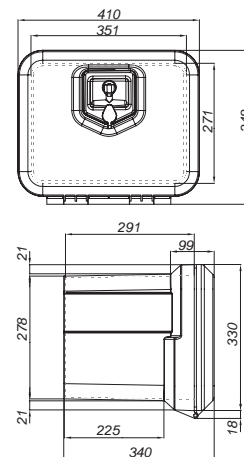

Plastic Tool Box 480x400x400 WELVET
 Kunststoff-Werkzeugkasten 480x400x400 WELVET
 Cajón Herramientas Plástico 480x400x400 WELVET

Ref	Kg	Mat	Col	Cap.Kg	Cap.L	Emark	Article	Lot
0201446	5	PP	●	50	39.5	E11	Box Cajón Montado	1

Injection molding | Smooth interior surface | Reinforced structure | PVC seal against water/dust ingress |
 Resistant (UV, flammability, oils, temperatures)
 Moldeo (inyección) | Superficie int. lisa | Estructura reforzada | Estanqueidad agua/polvo (Junta PVC) |
 Resistente (UV, fuego, aceites, temperaturas)
 ECE Regulation 73.01 | Lateral protection (VCA Homologation) | TÜV RHEINLAND Certification (IP59K)

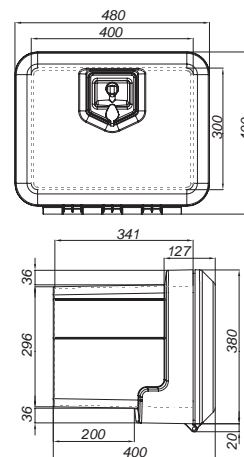

Plastic Tool Box 630x450x480 WELVET
 Kunststoff-Werkzeugkasten 630x450x480 WELVET
 Cajón Herramientas Plástico 630x450x480 WELVET

Ref	Kg	Mat	Col	Cap.Kg	Cap.L	Emark	Article	Lot
0201450	8	PP	●	60	78.5	E11	Box Cajón Montado	1

Injection molding | Smooth interior surface | Reinforced structure | PVC seal against water/dust ingress | Resistant (UV, flammability, oils, temperatures)
 Moldeo (inyección) | Superficie int. lisa | Estructura reforzada | Estanqueidad agua/polvo (Junta PVC) | Resistente (UV, fuego, aceites, temperaturas)
 ECE Regulation 73.01 | Lateral protection (VCA Homologation) | TÜV RHEINLAND Certification (IP59K)

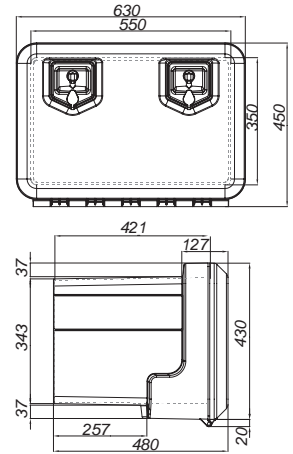

Plastic Tool Box 830x500x470 WELVET
 Kunststoff-Werkzeugkasten 830x500x470 WELVET
 Cajón Herramientas Plástico 830x500x470 WELVET

Ref	Kg	Mat	Col	Cap.Kg	Cap.L	Emark	Article	Lot
0201456	10.5	PP	●	65	120	E11	Box Cajón Montado	1

Injection molding | Smooth interior surface | Reinforced structure | PVC seal against water/dust ingress | Resistant (UV, flammability, oils, temperatures)
 Moldeo (inyección) | Superficie int. lisa | Estructura reforzada | Estanqueidad agua/polvo (Junta PVC) | Resistente (UV, fuego, aceites, temperaturas)
 ECE Regulation 73.01 | Lateral protection (VCA Homologation) | TÜV RHEINLAND Certification (IP59K)

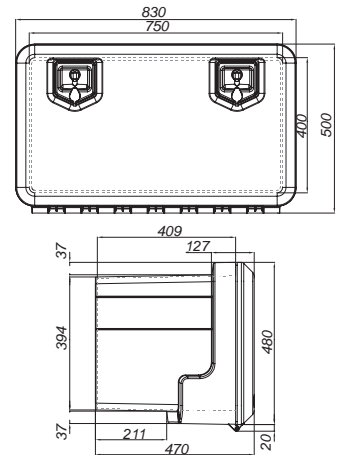

Plastic Tool Box 1030x500x480 WELVET
 Kunststoff-Werkzeugkasten 1030x500x480 WELVET
 Cajón Herramientas Plástico 1030x500x480 WELVET

Ref	Kg	Mat	Col	Cap.Kg	Cap.L	Emark	Article	Lot
0201458	13	PP	●	70	155.5	E11	Box Cajón Montado	1

Injection molding | Smooth interior surface | Reinforced structure | PVC seal against water/dust ingress | Resistant (UV, flammability, oils, temperatures)
 Moldeo (inyección) | Superficie int. lisa | Estructura reforzada | Estanqueidad agua/polvo (Junta PVC) | Resistente (UV, fuego, aceites, temperaturas)
 ECE Regulation 73.01 | Lateral protection (VCA Homologation) | TÜV RHEINLAND Certification (IP59K)

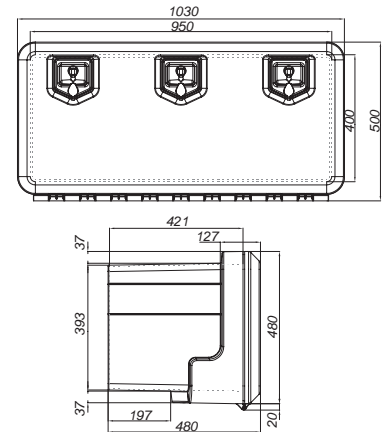

Plastic Tool Box 655x450x470 ARKA
 Kunststoff-Werkzeugkasten 655x450x470 ARKA
 Cajón Herramientas Plástico 655x450x470 ARKA

Ref	Kg	Mat	Col	Cap.Kg	Cap.L	Emark	Article	Lot
0201451	7.6	PP	●	80	74	E11	Box	1
0201564	5	PP	●	80	74		Body Box Cuerpo	1
0201565	2.7	PP	●				Cover Box tapa	1

Injection molding | Reinforcement ribs (stability/durability) | TPE seal against water/dust ingress | Resistant (UV, flammability, oils, temperatures)
 Moldeo (inyección) | Nervaduras reforzadas (solidez/resistencia) | Estanqueidad agua/polvo (Junta TPE) | Resistente (UV, fuego, aceites, temperaturas)
 ECE Regulation 73.01 | Lateral protection (VCA Homologation)

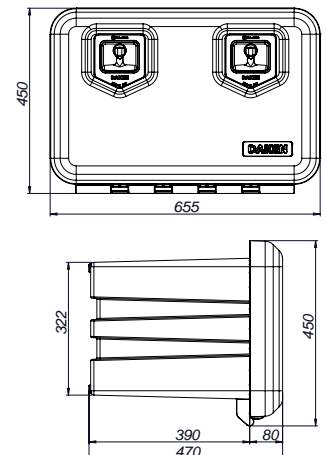

Plastic Tool Box 685x500x500 ARKA
 Kunststoff-Werkzeugkasten 685x500x500 ARKA
 Cajón Herramientas Plástico 685x500x500 ARKA

Ref	Kg	Mat	Col	Cap.Kg	Cap.L	E-mark	Article	Lot
0201452	8.5	PP	●	50	109	E11	Box Cajón Montado	1
0201568	4	PP	●	50	109		Body Box Cuerpo	1
0201569	2.5	PP	●				Cover Box Tapa	1

Injection molding | Reinforcement ribs (stability/durability) | TPE seal against water/dust ingress |
 Resistant (UV, flammability, oils, temperatures)
 Moldeo (inyección) | Nervaduras reforzadas (solidez/resistencia) | Estanqueidad agua/polvo (Junta TPE) |
 Resistente (UV, fuego, aceites, temperaturas)
 ECE Regulation 73.01 | Lateral protection (VCA Homologation)

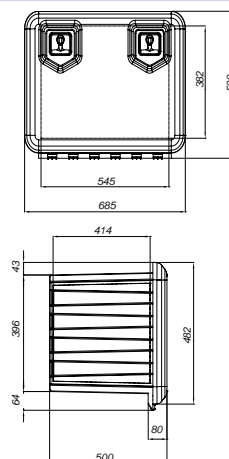

Plastic Tool Box 858x522x500 ARKA
 Kunststoff-Werkzeugkasten 858x522x500 ARKA
 Cajón Herramientas Plástico 858x522x500 ARKA

Ref	Kg	Mat	Col	Cap.Kg	Cap.L	E-mark	Article	Lot
0201455	10.7	PP	●	80	134	E11	Box Cajón Montado	1
0201580	7.1	PP	●	80	134		Body Box Cuerpo	1
0201581	4.3	PP	●				Cover Box Tapa	1

Injection molding | Reinforcement ribs (stability/durability) | TPE seal against water/dust ingress |
 Resistant (UV, flammability, oils, temperatures)
 Moldeo (inyección) | Nervaduras reforzadas (solidez/resistencia) | Estanqueidad agua/polvo (Junta TPE) |
 Resistente (UV, fuego, aceites, temperaturas)
 ECE Regulation 73.01 | Lateral protection (VCA Homologation)

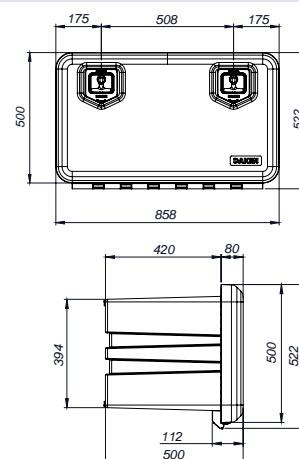

Plastic Tool Box 1062x522x500 ARKA
 Kunststoff-Werkzeugkasten 1062x522x500 ARKA
 Cajón Herramientas Plástico 1062x522x500 ARKA

Ref	Kg	Mat	Col	Cap.Kg	Cap.L	E-mark	Article	Lot
0201459	13.2	PP	●	80	169.4	E11	Box Cajón Montado	1
0201594	8.6	PP	●	80	169.4		Body Box Cuerpo	1
0201595	4.6	PP	●				Cover Box Tapa	1

Injection molding | Reinforcement ribs (stability/durability) | TPE seal against water/dust ingress |
 Resistant (UV, flammability, oils, temperatures)
 Moldeo (inyección) | Nervaduras reforzadas (solidez/resistencia) | Estanqueidad agua/polvo (Junta TPE) |
 Resistente (UV, fuego, aceites, temperaturas)
 ECE Regulation 73.01 | Lateral protection (VCA Homologation)

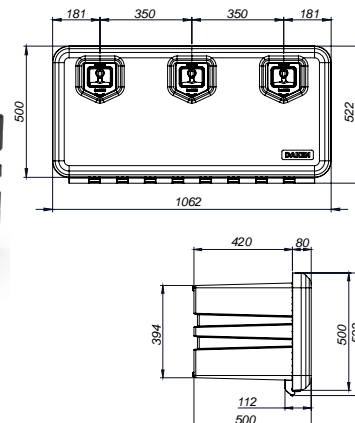

Plastic Tool Box 1250x524x500 ARKA
 Kunststoff-Werkzeugkasten 1250x524x500 ARKA
 Cajón Herramientas Plástico 1250x524x500 ARKA

Ref	Kg	Mat	Col	Cap.Kg	Cap.L	E-mark	Article	Lot
0201460	15	PP	●	115	203	E11	Box Cajón Montado	1
0201598	10.5	PP	●	115	203		Body Box Cuerpo	1
0201599	5	PP	●				Cover Box Tapa	1

Injection molding | Reinforcement ribs (stability/durability) | TPE seal against water/dust ingress |
 Resistant (UV, flammability, oils, temperatures)
 Moldeo (inyección) | Nervaduras reforzadas (solidez/resistencia) | Estanqueidad agua/polvo (Junta TPE) |
 Resistente (UV, fuego, aceites, temperaturas)
 ECE Regulation 73.01 | Lateral protection (VCA Homologation)

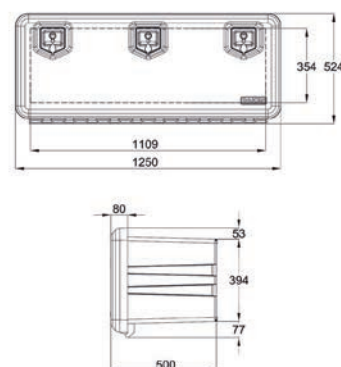

Plastic Tool Box 660x515x460 FLINK
 Kunststoff-Werkzeugkasten 660x515x460 FLINK
 Cajón Herramientas Plástico 660x515x460 FLINK

NEW

Ref	Kg	Mat	Col	Cap.Kg	Cap.L	Emark	Article	Lot
0201430	5.6	PP	●	50	92	E11	Box	1
0201566	4.2	PP	●	50	92		Body Box	1
0201567	1.4	PP	●				Cover Box	1

Injection molding | Compatible Bracket | Less environmental impact |
 Resistant (water-powder, UV, flammability, oils, temperatures)
 Moldeo (inyección) | Soportes Compatibles | Menor impacto ambiental |
 Resistente (agua-polvo, UV, fuego, aceites, temperaturas)
 ECE Regulation 73.01 | Lateral protection (VCA Homologation)

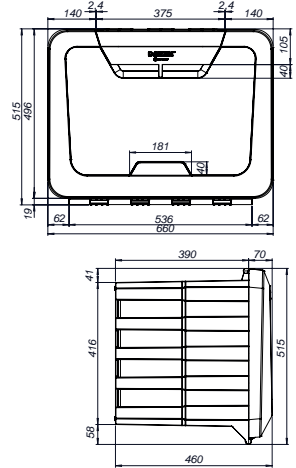

BOXES AND TANKS / WERKZEUGKÄSTEN UND WASSERTANKS / CAJONES Y BIDONES

Plastic Tool Box 550x255x310 BLACK LITE
 Kunststoff-Werkzeugkasten 550x255x310 BLACK LITE
 Cajón Plástico BLACKIT LITE 550x255x310

NEW

Ref	Kg	Mat	Col	Cap.Kg	Cap.L	Article	Lot
0201412	2.3	PP	●	20	24		1

Injection molding | PVC seal against water/dust ingress |
 Resistant (UV, flammability, water/dust, fuel and lubricating oil, high/low temperatures)
 Moldeo (inyección) | Estanqueidad agua/polvo (Junta PVC) | Cierre con cerradura |
 Resistente (golpes, vibraciones, UV, fuego, aceites, temperaturas)
 ECE Regulation 73.01 | Lateral protection (VCA Homologation)

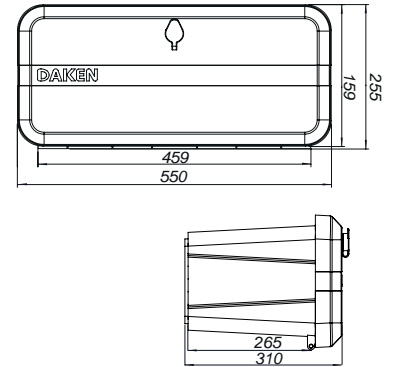

Plastic Tool Box 555x255x310 BLACK LITE Side Opening
 Kunststoff-Werkzeugkasten 555x255x310 BLACK LITE seitliche Öffnung
 Cajón Plástico BLACKIT LITE 555x255x310 Apertura Lateral

NEW

Ref	Kg	Mat	Col	Cap.Kg	Cap.L	Article	Lot
0201414	2.2	PP	●	20	24		1

Injection molding | PVC seal against water/dust ingress |
 Resistant (UV, flammability, water/dust, fuel and lubricating oil, high/low temperatures)
 Moldeo (inyección) | Estanqueidad agua/polvo (Junta PVC) | Cierre con cerradura |
 Resistente (golpes, vibraciones, UV, fuego, aceites, temperaturas)
 ECE Regulation 73.01 | Lateral protection (VCA Homologation)

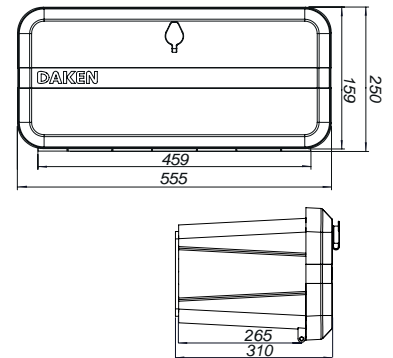

Plastic Document Tube Box Ø95x342
 Dokumententasche Ø95x342 Kunststoff Rohr
 Tubo Portadocumentos Ø95x342 Plástico

Ref	Kg	Mat	Col	Metric	Lot
7202184	0.48			M8	1

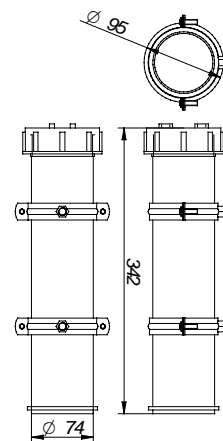

Plastic Document Tube Box Ø98x304
 Dokumententasche Ø98x304 Kunststoff Rohr
 Tubo Portadocumentos Ø98x304 Plástico

Ref	Kg	Mat	Col	Lot
7202185	0.33			1

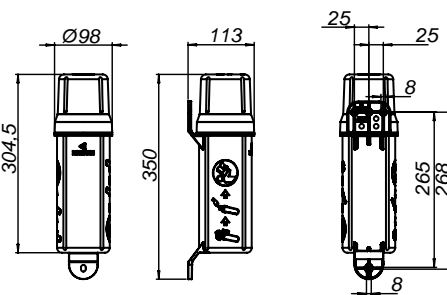

Plastic Document Tube Box Ø124x340
 Dokumententasche Ø124x340 Kunststoff Rohr
 Tubo Portadocumentos Ø124x340 Plástico

Ref	Kg	Mat	Col	Lot
7202186	0.36			1

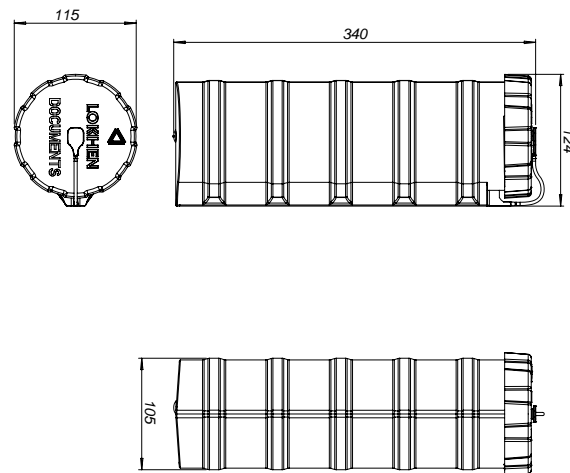

Plastic Document Box 318x367x74
 Dokumententasche 318x367x74 Plastik
 Portadocumentos 318x367x74 Plástico

Ref	Kg	Mat	Col	Lot
7202188	0.65			1

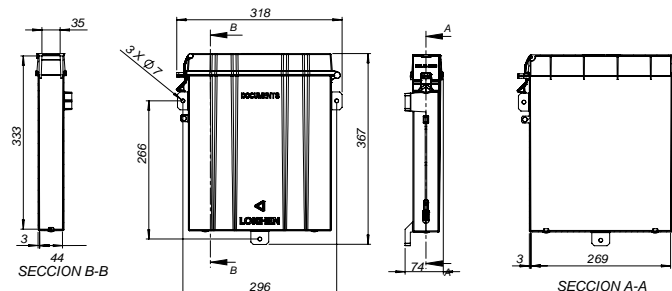



2 Brackets Set, KTL
Halterungs-Satz KTL für Werkzeugkasten
Kit 2 Soportes Caja Herramientas KTL

Ref	Kg	Mat	Sup/Finish Acabado	Thickn. Espesor	Lot
0201498	3.79	STEEL	KTL	3	1

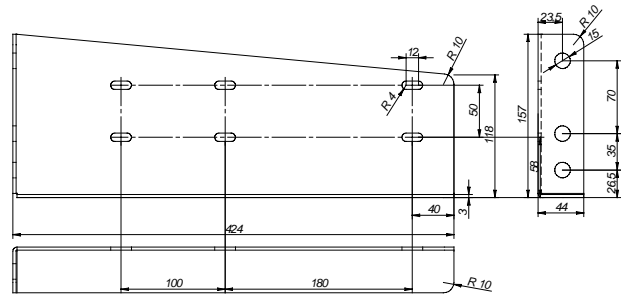

Horizontal Brackets Set for Box, KTL
Halterungs-satz Horizontal KTL
Kit 2 Soportes Caja Herramientas KTL

Ref	Kg	Mat	Sup/Finish Acabado	Thickn. Espesor	Lot
0201494	5.8	STEEL	KTL	3	1

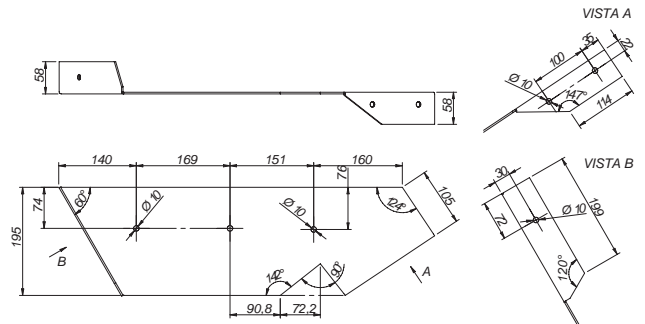

Rectangular Adjustable Brackets for Tool Box
Halterungs-Satz Rechteckig Verstellbar
Soporte Caja Herramientas Rectangular Regulable

NEW

Ref	Kg	Mat	Sup/Finish Acabado	Thickn. Espesor	Lot
0106092	1.9	STEEL	Zn	3	1

Suitable for other applications | Finish: Zinc Plated Steel+Sealant
Apto para otras aplicaciones | Acabado: Cincado+Sellado

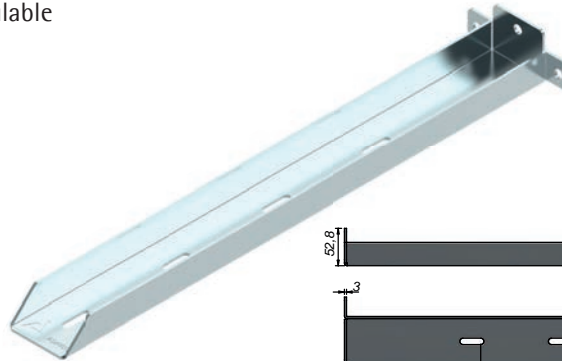

Bracket for FLINK Tool Box 0201430
Halterungs-Satz für FLINK 0201430 Werkzeugkaste
Soporte para Cajón FLINK 0201430

NEW

Ref	Kg	Mat	Thickn. Espesor	Lot
0106094	1.9	STEEL	2	1

Magnelis® Steel
Acero Magnelis®

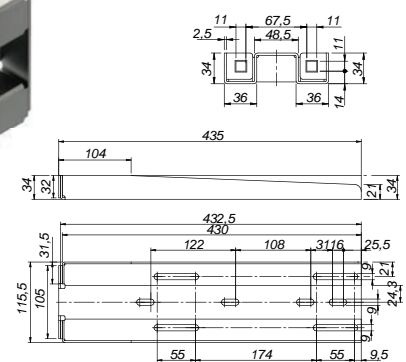
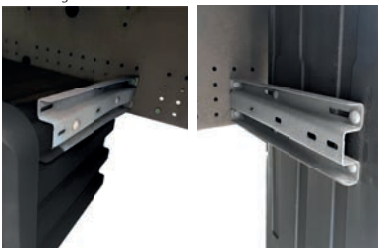



TOOL BOX ACCESSORIES / WERKZEUGKOFFERZUBEHÖR / ACCESORIOS_CAJON HERRAMIENTAS

BOXES AND TANKS / WERKZEUGKÄSTEN UND WASSERTANKS / CAJONES Y BIDONES

MAGNELIS Steel Horizontal Brackets Set (Box <550mm.)
Halterungs-Satz Horizontal MAGNELIS (Kasten <550mm.)
Kit Soportes Horizontales MAGNELIS (Cajón <550mm.)

Ref	Kg	Mat	Pos	Thickn. Espesor	Strength Fuerza	Lot
0201474	2.5	STEEL		2	150 kg	1

Magnelis® Steel
Soportes de Magnelis®

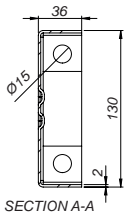
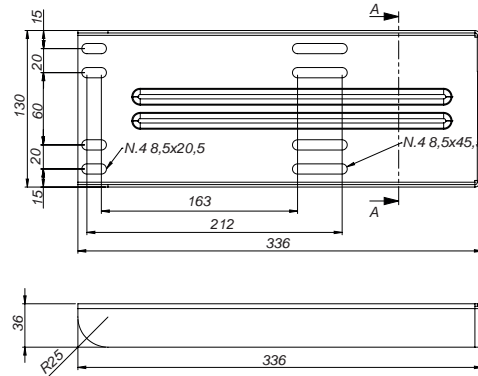
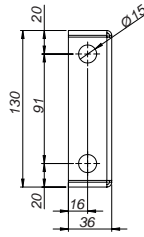

Black Steel Horizontal Brackets Set (Box <550mm.)
Halterungs-Satz Horizontal Schwarz (Kasten <550mm.)
Kit Soportes Horizontales Negros (Cajón plástico <550mm.)

Ref	Kg	Mat	Sup/Finish Acabado	Col	Pos	Thickn. Espesor	Strength Fuerza	Lot
0201470	2.5	STEEL				2	150 kg	1

Epoxy-powder coated steel brackets with GEOMET coated fixing kit
Soportes de acero pintado en negro con polvo epoxidico | Kit para fijación con acabado GEOMET

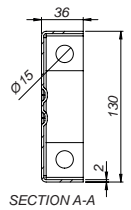
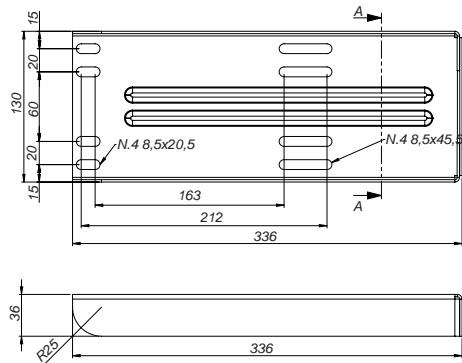
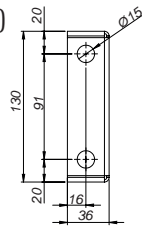

MAGNELIS Steel Horizontal Brackets Set (Box >600mm.)
Halterungs-Satz Horizontal MAGNELIS (Kasten >600mm.)
Kit Soportes Horizontales MAGNELIS (Cajón >600mm.)

Ref	Kg	Mat	Pos	Thickn. Espesor	Strength Fuerza	Lot
0201475	3.5	STEEL		2	150 kg	1

Magnelis® Steel
Soportes de Magnelis®

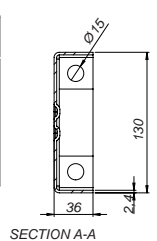
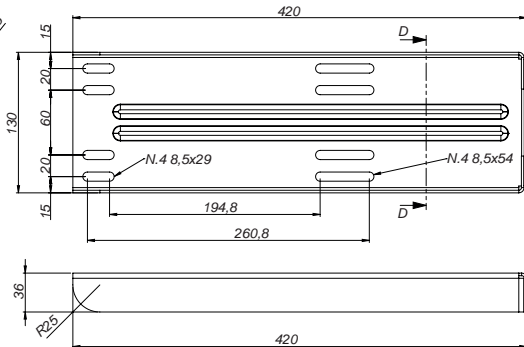
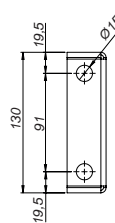

Black Steel Horizontal Brackets Set (Box >600mm.)
Halterungs-Satz Horizontal Schwarz (Kasten >600mm.)
Kit Soportes Horizontales Negros (Cajón >600mm.)

Ref	Kg	Mat	Sup/Finish Acabado	Col	Pos	Thickn. Espesor	Strength Fuerza	Lot
0201471	3.5	STEEL				2	150 kg	1

Epoxy-powder coated steel brackets with GEOMET coated fixing kit
Soportes de acero pintado en negro con polvo epoxidico | Kit para fijación con acabado GEOMET

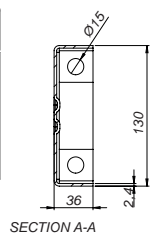
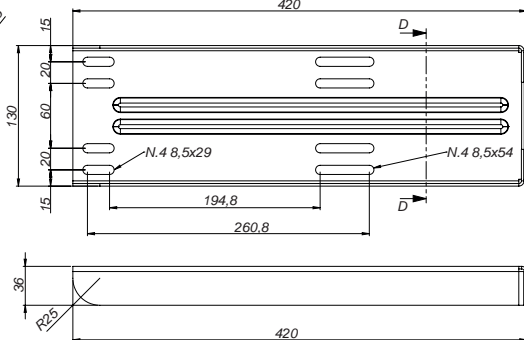
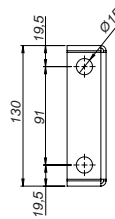

TOOL BOX ACCESSORIES / WERKZEUGKOFFERZUBEHÖR / ACCESORIOS_CAJON HERRAMIENTAS



BOXES AND TANKS / WERKZEUGKÄSTEN UND WASSERTANKS / CAJONES Y BIDONES

Horizontal Brackets Set for Box >600 mm.
Halter-Satz Horizont. Kunststoffwerkzeugkästen >600 mm
Kit Soportes Horizontales para Cajón >600 mm

Ref	Kg	Mat	Sup/Finish Acabado	Col	Pos	Thickn. Espesor	Strength Fuerza	Lot
0201483	4	STEEL				3	150 kg	1

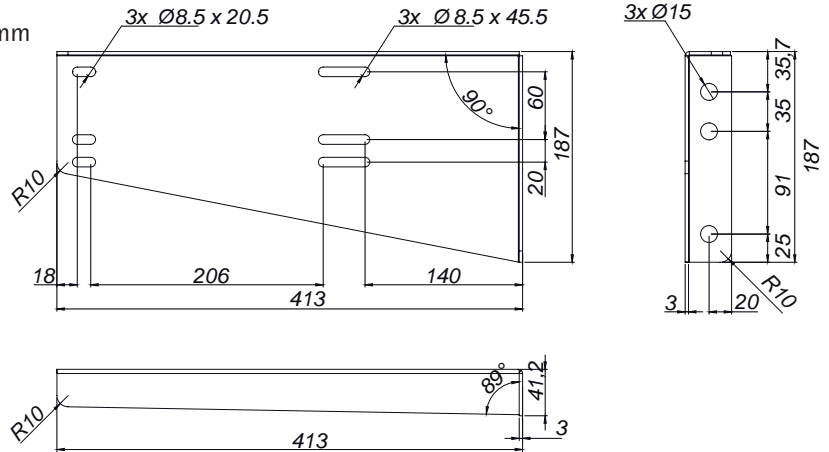

Universal Zinc Plated Steel Vertical Brackets Set
Halterungs-Satz Universal Vertikal Verzinkt
Kit Soportes Verticales Cincado Universal

Ref	Kg	Mat	Sup/Finish Acabado	Pos	Thickn. Espesor	Strength Fuerza	Lot
0201481	1.7	STEEL	Zn		6	200 kg	1

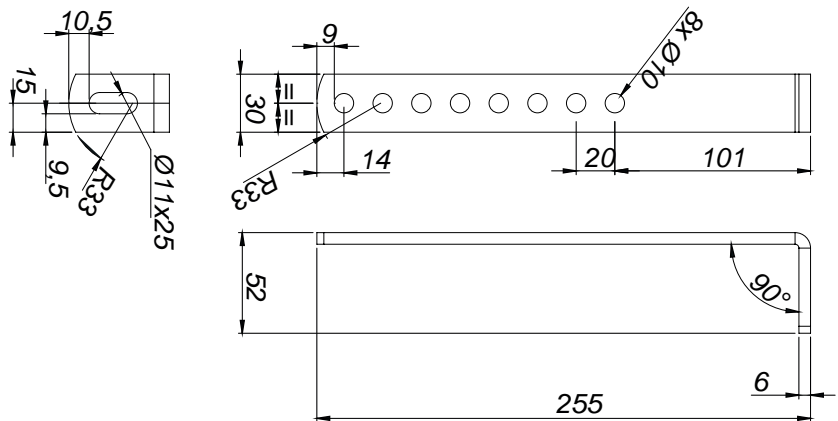

Zinc Plated Steel Hor-Ver Brackets Set
Halterungs-Satz Horiz./Vertik. Verzinkt
Kit Soportes Hor-Ver Cincados

Ref	Kg	Mat	Sup/Finish Acabado	Pos	Thickn. Espesor	Strength Fuerza	Lot
0201485	3.9	STEEL	Zn		2	150 kg	1

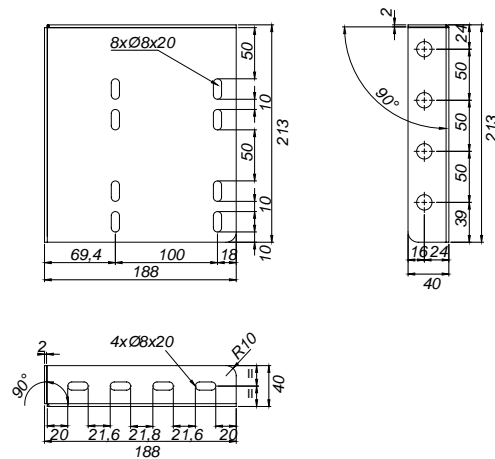

Type "U" Bracket for Toolbox 0201460
Umlaufende halter für Kasten 0201460
Soporte Tipo "U" para Cajón 0201460

Ref	Kg	Mat	Sup/Finish Acabado	Col	Pos	Thickn. Espesor	Lot
0201489	3.9	STEEL				3	1

Epoxy-powder coated "U" bracket" to be combined with vertical or horizontal brackets
Soporte de acero envolvente pintado en negro con polvo epoxídico, para asociar a los soportes verticales u horizontales.

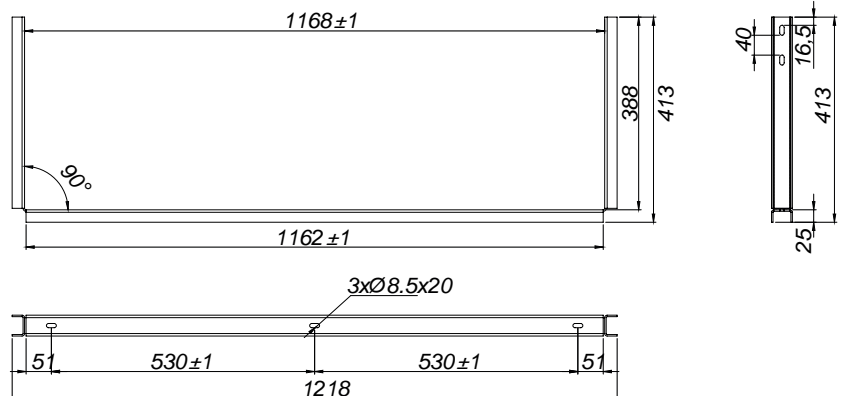



TOOL BOX ACCESSORIES / WERKZEUGKOFFERZUBEHÖR / ACCESORIOS_CAJON HERRAMIENTAS

BOXES AND TANKS / WERKZEUGKÄSTEN UND WASSERTANKS / CAJONES Y BIDONES

Plastic Paddle Lock for ADABOX
Kunststoff Kastenverschluss für ADABOX
Cierre plástico para Cajón ADABOX

Ref	Kg	Key Llave	Lot
1203001	0.56		1

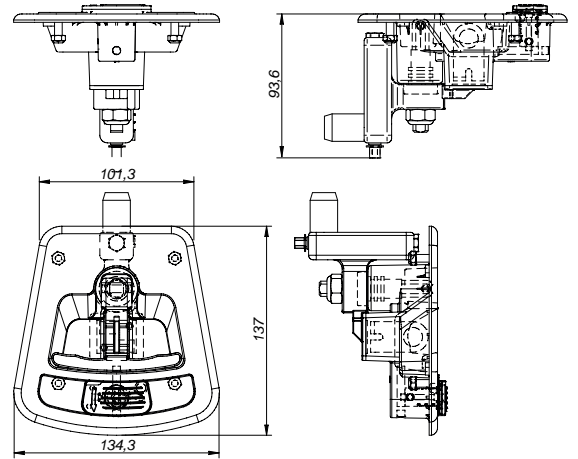

Nylon Paddle Lock 120x100 for 0201444
Kastenverschluss 120x100 Nylon für 0201444
Cierre Cajón 120x100 Nylon para 0201444

Ref	Kg	Mat	Key Llave	Lot
1203008	0.26	Ny		1

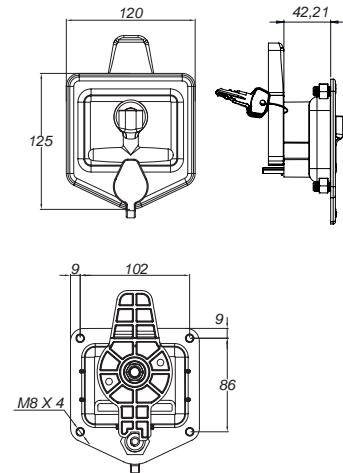

Nylon Paddle Lock 120x100 for 0201446/50/56/58
Kastenverschluss 120x100 Nylon für 0201446/50/56/58
Cierre Cajón 120x100 Nylon para 0201446/50/56/58

Ref	Kg	Mat	Key Llave	Lot
1203004	0.28	Ny		1

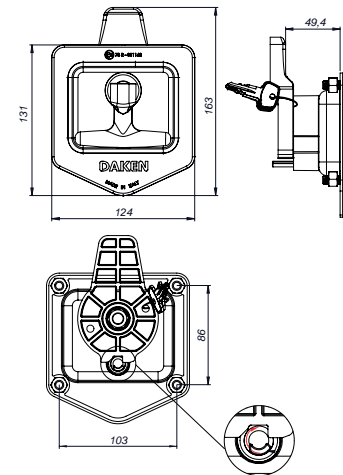

Plastic Paddle Lock for 0201451/52/55/59/60
Kastenverschluss Kunststoff für 0201451/52/55/59/60
Cierre Cajón para 0201451/52/55/59/60

Ref	Kg	Mat	Key Llave	Lot
1203019	0.25	Ny		1



NEW

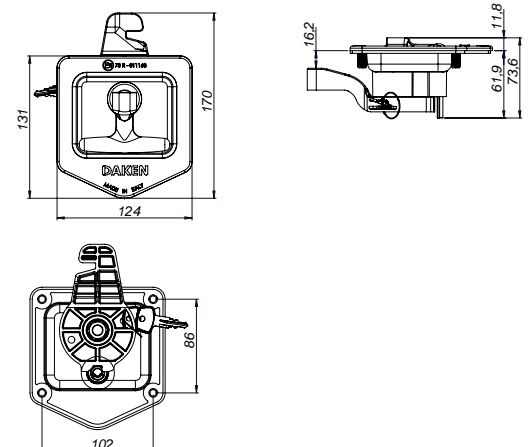

Nylon Paddle Lock for JUST Box
Verschluss Nylon für JUST Kasten
Cierre Nylon p/Cajón JUST

Ref	Kg	Mat	Emark	Key Llave	Lot
1203011	0.2	Ny	E11		1

2 keys
2 llaves
ECE Regulation 73.01



Plastic Lock for 0201430
Kastenverschluss Kunststoff für 0201430
Cierre Cajón Plástico para 0201430

NEW

Ref	Kg	Mat	Lot
1203006	5.6		1



Lock for ADABOX 0292105 y 1782113/14/16
Kastenverschluss für ADABOX 0292105 y 1782113/14/16
Cierre para Cajón ADABOX 0292105 y 1782113/14/16

NEW

Ref	Kg	Lot
1203064	0.2	1

Special Lock for ADABOX boxes: Box for Corner Protectos 0292105 and Pallet Box 1782113/14/16
Cierre especial para cajones ADABOX: Cajón para Cantoneras 0292105 y Portapalets 1782113/14/16

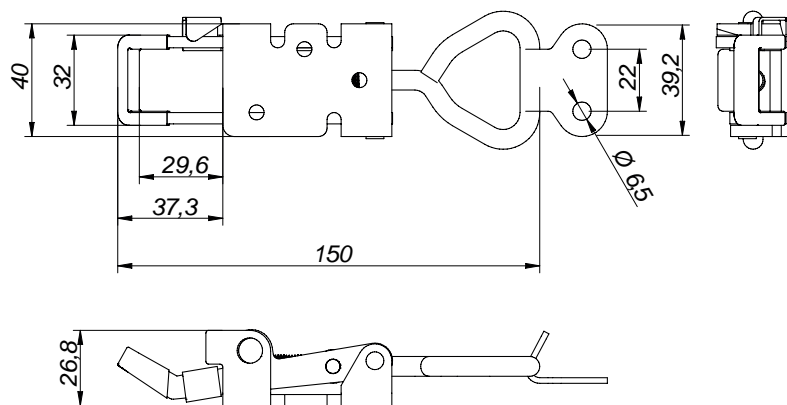

2 Set Hinges for ADABOX, metal shaft
2 Set Scharniere für ADABOX, Metallachse
Kit 2 Bisagras p/Cajón ADABOX, eje metálico

Ref	Kg	Mat	Lot
0298020	0.06	STEEL	1

Metallic shaft
Eje metálico





TOOL BOX ACCESSORIES / WERKZEUGKOFFERZUBEHÖR / ACCESORIOS_CAJON HERRAMIENTAS

BOXES AND TANKS / WERKZEUGKÄSTEN UND WASSERTANKS / CAJONES Y BIDONES

2 Set Hinges for ADABOX 0282180/82, metal shaft
2 Set Scharniere für ADABOX 0282180/82, Metallachse
Kit 2 Bisagras p/Cajón ADABOX 0282180/82, eje metálico

Ref	Kg	Mat	Sup/Finish Acabado	Col	Lot
0298022	0.02	STEEL			1

Metallic shaft
Eje metálico

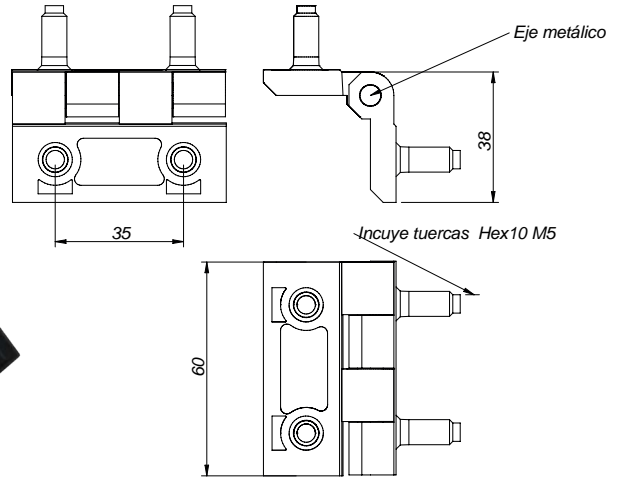

Hinge for ADABOX 0292105 metal shaft
Scharniere für ADABOX 0292105 Metallachse
Bisagra p/Cajón ADABOX 0292105, eje metálico

NEW

Ref	Kg	Mat	Sup/Finish Acabado	Col	Lot
0298026	0.1	STEEL			1

Metallic shaft
Eje metálico

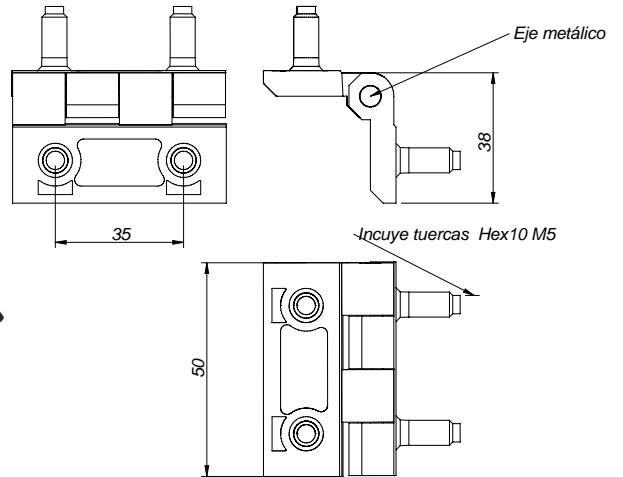

2 Set Gas Spring for ADABOX
2 Set Gasfeder für ADABOX
Kit 2 Amortiguadores para Cajón ADABOX

Ref	Kg	Lot
0298011	0.26	1

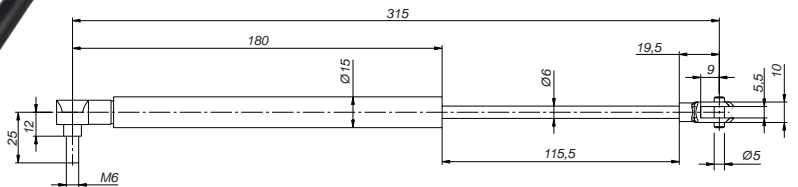

Steel Cable for ADABOX H=400-500
Stahlkabel für ADABOX H=400-500
Kit 2 cables p/Cajón ADABOX H=400-500

NEW

Ref	Kg	Mat	Lot
0298024	0.26	STEEL	1

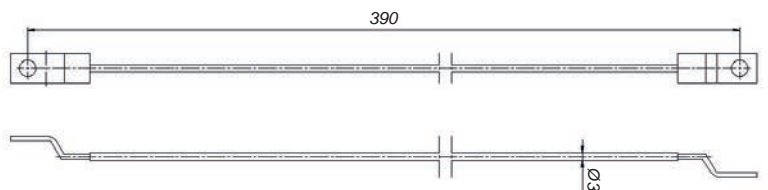

Pack 2 Chains for Plastic Box
2 Stück kette für Kunststoff Kasten
Pack 2 Cadenas para Cajones de Plástico

NEW

Ref	Kg	Mat	Sup/Finish Acabado	Article	Lot
0298034	0.1	STEEL	Zn	for 0201450/56/58/52/55/59/42 para 0201450/56/58/52/55/59/42	1
0298035	0.1	STEEL	Zn	for 0201441/43/53/54 para 0201441/43/53/54	1
0298036	0.1	STEEL	Zn	for 0201446/57/51 para 0201446/57/51	1



Profile Roll 25m. for ADABOX
Gummidicht-Profil 25m. für Kiste ADABOX
Rollo Perfil Goma 25m. para Cajón ADABOX

NEW

Ref	Kg	Mat	Col	Lot
0298004	3			1

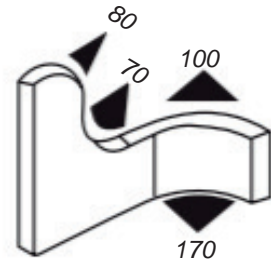
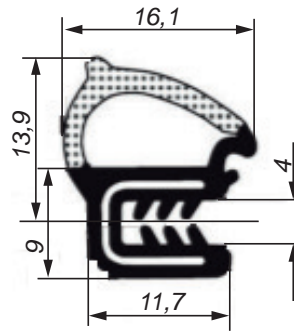

FIRE & SECURITY

BOXES AND TANKS / WERKZEUGKÄSTEN UND WASSERTANKS / CAJONES Y BIDONES

Ref.	Ext.	Dimensions Medidas	FIXATIONS / FIJACIONES								
			Supports / Soportes				Fire Extinguisher Lock / Bloqueo Extintor				
			0201500	0201495	0201496	0201498	0298012	0298001	0298002	0298032	
0201194		335x620x240	x	x	✓	x	✓	x	✓	x	REGON
0201196		335x715x240	x	x	✓	x	x	✓	✓	x	REGON
0201198		335x865x240	x	x	✓	x	x	✓	✓	x	ADAMANT
0201192		310x671x247	x	✓	x	x	✓	x	✓	x	ADAMANT
0201195		310x671x247	x	✓	x	x	x	✓	✓	x	ADAMANT
0201189		284x595x265	✓	x	x	x	x	x	x	x	SLIDEN
0201191		284x595x265	✓	x	x	x	x	x	x	x	SLIDEN
0201174		324x750x309	✓	x	x	x	✓	x	x	x	SLIDEN
0201188		616x735x270	x	x	x	x	x	✓	x	x	DUAL
0201176		287x600x220	x	x	✓	x	✓	x	✓	x	STRIKE
0201160		321x707x239	x	x	✓	x	x	✓	✓	x	STRIKE
0282232		300x700x240	x	x	x	✓	x	x	x	✓	ADABOX
0282230		470x700x240	x	x	x	✓	x	x	x	✓	ADABOX



PACKAGING OPTIONS / OPCIONES DE EMBALAJE

Ref.	Box Dimensions Medidas Cajón	Body Cuerpo	Cover Tapa	Box TO BE ASSEMBLED (Body+Cover) Cajón DESMONTADO (Cuerpo+Tapa)		Box ASSEMBLED Cajón MONTADO		Model Modelo
				WxLxH Pallet WxLxH Pallet	Quantity Cantidad	WxLxH Pallet WxLxH Pallet	Quantity Cantidad	
				0201194	335x620x240	-	-	
0201196	335x715x240	0201166	0201167	75x128x245 cm.	60	74x137x271 cm.	40	REGON
0201198	335x865x240	-	-	-	-	35x88x27 cm.	40	REGON
0201192	310x671x247	-	-	-	-	97x137x254 cm.	54	ADAMANT
0201195	310x671x247	-	-	-	-	97x137x254 cm.	54	ADAMANT
0201189	284x595x265	-	-	-	-	90x120x267 cm.	54	SLIDEN
0201191	284x595x265	-	-	-	-	87x127x267 cm.	54	SLIDEN
0201174	324x750x309	-	-	-	-	87x127x267 cm.	24	SLIDEN
0201188	616x735x270	-	-	-	-	75x128x265 cm.	18	DUAL
0201176	287x600x220	0201182	0201183/84	93x130x264	120	90x120x240 cm.	60	STRIKE
0201160	321x707x239	-	-	-	-	75x135x270 cm.	40	STRIKE
0282232	300x700x240	-	-	-	-	70x100x300 cm.	30	ADABOX
0282230	470x700x240	-	-	-	-	70x100x300 cm.	18	ADABOX

PLASTIC line

BOXES AND TANKS / WERKZEUGKÄSTEN UND WASSERTANKS / CAJONES Y BIDONES



REGON



E11
73R-011168

Material: Polypropylene, Nylon, Polycarbonate.
Production Process: injection moulding.
TUV Certification: tested for resistance to water and dust ingress (IP59K).
VCA Homologation: the product is approved as lateral protection system (ECE-R73.01).

Material: Polipropileno, Nylon, Policarbonato
Proceso fabricación: Moldeo por inyección.
Certificación TUV: Prueba de estanqueidad superada (IP59K).
Homologación VCA: Cumple la normativa ECE-R73.01 como sistema de protección lateral.

- Inspection window with "OR" seal for a better water resistance
Visor de inspección con junta "OR" para mayor estanqueidad
- Fire extinguisher holding kit composed of: PVC clamping spring with 4 attachment points and nylon clamping ring available in 2 sizes (Ø 150/170 mm, Ø170/190 mm)
Kit de bloqueo extintor compuesto por: correa de sujeción en pvc con 4 puntos de enganche y anillo de bloqueo en nylon en dos medidas (Ø 150/170 mm, Ø 170/190 mm)
- Innovative labyrinth system against water and dust ingress (IP59K, TÜV)
Sistema laberinto innovador para mayor estanqueidad al agua y polvos (IP59K, TÜV)
- Lockable to ensure maximum security
Cerradura con candado (no incluido) para garantizar mayor seguridad

Accessories / Accesorios



Homologated Fire Extinguisher REGON
 Feuerlöscherkasten Anerkannt REGON
 Cajón Extintor Homologado REGON

Ref	Kg	Mat	A	B	Ø	Emark	Part	Lot
0201194	2.92	PP	620	562	Ø150-170	E11	6 Kg	1
0201196	3.2	PP	715	657	Ø170-190	E11	9 Kg	1
0201198	2.9	PP	865	807	Ø170-190	E11	12 Kg	1

Injection molding | Load stability | Components resistance to high and low temperatures | Dust and water resistance
 Moldeo por inyección | Estabilidad a la carga | Resistencia de los componentes a baja y alta temperatura | Estanqueidad al agua y al polvo
 ECE Regulation 73.01

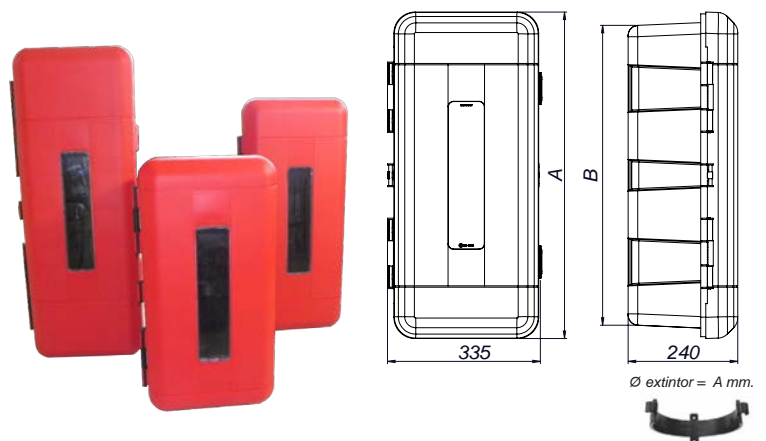



PLASTIC line

BOXES AND TANKS / WERKZEUGKÄSTEN UND WASSERTANKS / CAJONES Y BIDONES



ADAMANT

Material: Polypropylene, Nylon, Polycarbonate.

Production Process: injection moulding.

TUV Certification: the product has been tested for resistance to water and dust ingress (IP59K), accelerated weathering, flammability, compression and resistance to fuel and lubricating oil. The product functionality has not been compromised.

VCA Homologation: the product is approved as lateral protection system (ECE-R73.01).

Material: Polipropileno, Nylon, Policarbonato.

Proceso fabricación: Moldeo por inyección.

Certificación TUV: El producto ha sido sometido a varias pruebas: resistencia al agua y polvo (IP59K), envejecimiento acelerado, inflamabilidad, compresión y resistencia a hidrocarburos y aceites lubricantes. La funcionalidad del producto no ha sido comprometida.

Homologación VCA: Cumple la normativa ECE-R73.01 como sistema de protección lateral.

Accessories / Accesorios



0201495

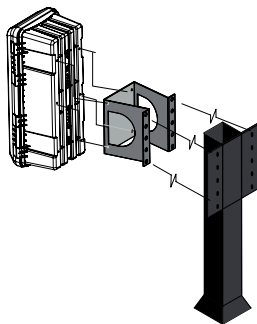

73R-011168

- Inspection window with "OR" seal for a better water resistance. *Visor de inspección con junta "OR" para mayor estanqueidad de agua y polvo.*
- Fire extinguisher holding kit composed of nylon clamping ring available in 2 sizes (Ø150/170mm. - Ø170/190mm.) and PVC clamping spring with 4 attachment points. *Kit de bloqueo extintor compuesto por: correa de sujeción en pvc con 4 puntos de enganche y anillo de bloqueo en nylon en dos medidas (Ø 150/170 mm, Ø 170/190 mm).*
- Internal PVC seal against water and dust ingress (IP59K, TÜV). *Junta de estanqueidad en PVC al agua y polvo (IP59K, TÜV).*
- Lockable or sealable to ensure maximum security against robberies and tampering. *Cerradura con candado (no incluido) para garantizar mayor seguridad.*

Homologated Fire Extinguisher Box inspection window ADAMANT
Feuerlöscherkasten Anerkannt mit Inspektionsfenster ADAMANT
Cajón Extintor Homologado c/Ventana ADAMANT

Ref	Kg	Mat	Ø	E mark	Part	Lot
0201192	2.87	PP	Ø160	E11	6 Kg	1
0201195	2.87	PP	Ø180	E11	9 Kg	1

Injection molding | inflammability test | Degradation test (UV rays) | IP 59K sealing test | Mechanical resistance to high and low temperatures
Moldeo por inyección | Test inflamabilidad | Test envejecimiento (rayos UV) | Test IP 59K | Test resistencia mecánicas (altas-bajas temperaturas)
ECE Regulation 73.01

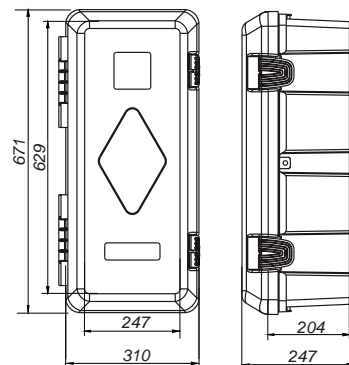

Ø extintor = A mm.



PLASTIC line

BOXES AND TANKS / WERKZEUGKÄSTEN UND WASSERTANKS / CAJONES Y BIDONES



SLIDEN

Material: Polypropylene, Nylon.
Production Process: injection moulding.
VCA Homologation: the product is approved as lateral protection system. (ECE-R73.01)
TUV Certification: Flammability (Flame Speed), Dust and water resistance (IP59K), Resistance to hydrocarbons and lubricating oils, Accelerated weathering (UV rays), Compression (12.000 N).

Material: Polipropileno, Nylon.
Proceso fabricación: Moldeo por inyección.
Certificación TUV: Inflamabilidad, Estanqueidad al agua y polvo (IP59K), Resistencia a hidrocarburos y aceites lubricantes, Envejecimiento acelerado (rayos UV), Compresión (Hasta 12,000 N).
Homologación VCA: Cumple la normativa ECE-R73.01 como sistema de protección lateral.

E₅₇
73R-010013



- Innovative reinforced and non-deformable structure to guarantee solidity and resistance in time.
Estructura reforzada innovadora e indeformable para garantizar solidez y resistencia en el tiempo.
- Inspection window (only 0201191).
Visor de inspección (sólo en el 0201191).
- Nylon tension spring for fire extinguisher (Ø140/160 mm) and extra tension springs (optional) for fire extinguishers <Ø140 mm.
Soporte elástico de bloqueo para extintores en nylon (Ø40/160 mm.), con la posibilidad de insertar soportes elástico adicionales para extintores con dimensiones <Ø140 mm.
- Internal TPE seal against water and dust ingress.
Junta interior de TPE para estanqueidad al agua y polvo.
Nylon handle sealable or lockable to guarantee more security against thefts and mishandling.
- Tirador de nylon con la posibilidad de insertar un candado o un sello para garantizar una mayor seguridad contra el robo y la manipulación.



Fire Extinguisher Box 6Kg. SLIDEN
 Feuerlöscherkasten 6Kg. SLIDEN
 Cajón Extintor 6Kg. SLIDEN

Ref	Kg	Mat	Col	Ø	Emark	Article	Part	Lot
0201189	2.1	PP	Black	Ø140-160	E ₅₇	No window Sin ventana	6 Kg	1
0201191	2.1	PP	Red	Ø140-160	E ₅₇	With Window Con Ventana	6 Kg	1

Injection molding | inflammability test | Degradation test (UV rays) | IP 59K sealing test | Mechanical resistance to high and low temperatures
 Moldeo por inyección | Test inflamabilidad | Test envejecimiento (rayos UV) | Test IP 59K | Test resistencia mecánicas (altas-bajas temperaturas)
 ECE Regulation 73.01

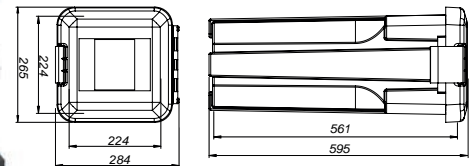

Ø extintor = A mm.

Fire Extinguisher Box 9/12 Kg. SLIDEN
 Feuerlöscherkasten 9/12 Kg. SLIDEN
 Cajón Extintor 9/12Kg. SLIDEN

Ref	Kg	Mat	Col	Ø	Emark	Article	Part	Lot
0201174	3.2	PP	Red	Ø200	E ₅₇	With Window Con Ventana	9/12 Kg	1

Injection molding | inflammability test | Degradation test (UV rays) | IP 59K sealing test | Mechanical resistance to high and low temperatures
 Moldeo por inyección | Test inflamabilidad | Test envejecimiento (rayos UV) | Test IP 59K | Test resistencia mecánicas (altas-bajas temperaturas)
 ECE Regulation 73.01

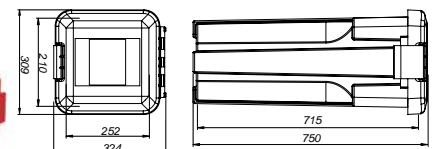

Ø extintor = A mm.



PLASTIC line

BOXES AND TANKS / WERKZEUGKÄSTEN UND WASSERTANKS / CAJONES Y BIDONES



DUAL

Material: Polypropylene, nylon, polycarbonate.
 Production Process: injection moulding.
 VCA Homologation: the product is approved as lateral protection system.
 (ECE-R73.01)

Material: Polipropileno, Nylon, Policarbonato
 Proceso fabricación: Moldeo por inyección
 Homologación VCA: Cumple la normativa ECE-R73.01 como sistema de protección lateral.



73R-011168

- Reinforced structure to ensure solidity and durability.
 Estructura reforzada para garantizar solidez y resistencia en el tiempo.
- Inspection window (optional) with "OR" seal for a better water resistance.
 Visor de inspección con junta "OR" para mayor estanqueidad.
- Fire extinguisher holding kit composed of: 2 or 4 nylon clamping ring available in 2 sizes (Ø 150/170, Ø170/190 mm) and PVC clamping springs with 4 attachment points.
 Kit de bloqueo extintor compuesto por: correa de sujeción en pvc con 4 puntos de enganche y anillo de bloqueo en nylon en dos medidas
- Internal TPE seal against dust and water ingress.
 Junta de estanqueidad en EPDM al agua y polvos.
- Nylon handles suitable for padlock.
 Tiradores cerrables con candado (no incluido) para garantizar mayor seguridad



Homologated Double Fire Extinguisher Box DUAL
 Kunststoff-Feuerlöscherkasten Doppelt DUAL
 Cajón Extintor Doble Homologado DUAL

Ref	Kg	Mat	Ø	Thickn. Espesor	Emark	Part	Lot
0201188	7	PP	Ø170-190	4	E11	9 kg	1

Injection molding | with Inspection window | Black body and red cover | 4 rings | Double Nylon Lock
 Moldeo por inyección | c/Ventana Inspección | Cuerpo en negro y tapa roja | 4 anillos | Correa para la estanqueidad | Doble cierre Nylon
 ECE Regulation 73.01

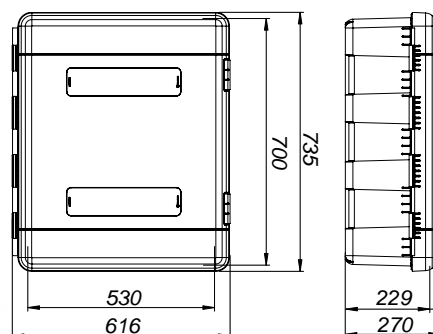

Ø extintor = A mm.





PLASTIC line



- Co-injected inspection window.
Visor de inspección co-imprimido.
- Fire extinguisher holding kit composed of nylon clamping ring and PVC clamping spring with 4 attachment points.
Kit de bloqueo extintor con conexión de bayoneta. Compuesto por: anillo de bloqueo de nylon y correa de sujeción en PVC con 4 puntos de enganche.
- Internal PVC seal against water and dust ingress.
Junta interna de PVC para la estanqueidad al agua y polvo.
- Lockable or sealable to ensure maximum security against robberies and tampering
Posibilidad de insertar candado (opcional) o sello para garantizar mayor seguridad contra robo y manipulación.
- Reinforcement ribs to ensure stability and durability.
Nervaduras reforzadas para garantizar solidez y resistencia en el tiempo.
- Logistics optimisation: the products can be delivered dismantled and stacked in piles. Fast and easy to assemble.
Optimización logística: posibilidad de recibir el producto desmontado y apilado. Montaje rápido e intuitivo

Material: Polypropylene, nylon, polycarbonate.
Production Process: injection moulding.
VCA Homologation: the product is approved as lateral protection system (ECE-R73.01).

Material: Polipropileno, Nylon, Policarbonato
Proceso fabricación: Moldeo por inyección
Homologación VCA: Cumple la normativa ECE-R73.01 como sistema de protección lateral.

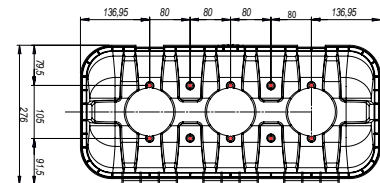

Homologated Fire Extinguisher Box 6Kg. STRIKE
Feuerlöscherkästen Anerkannt 6Kg. STRIKE
Cajón Extintor Homologado 6kg. STRIKE

Ref	Kg	Mat	Col	Ø	Emark	Article	Part	Lot
0201176	1.9	PP		Ø160	E11	Box Assembled Cajón Montado	6 Kg	1
0201177 NEW	1.9	PP		Ø160	E11	Disassembled Full Pallet Desmontado Pallet Completo	6 Kg	120
0201184 NEW	0.4	PP	●			Cover Tapa		1
0201182	1.13	PP	●			Body Box (without ring) Cuerpo (sin anillo bloqueo)	6 Kg	1
0201183	0.4	PP	●			Cover Tapa		1

Injection molding | Reinforcement ribs | Co-injected inspection window | nylon+PVC clamping spring | PVC seal | Lockable or sealable maximum security
Moldeo por inyección | Nervios reforzados | Visor de inspección | Kit bloqueo extintor (bayoneta) | Junta PVC | Posibilidad de insertar candado/sello
ECE Regulation 73.01

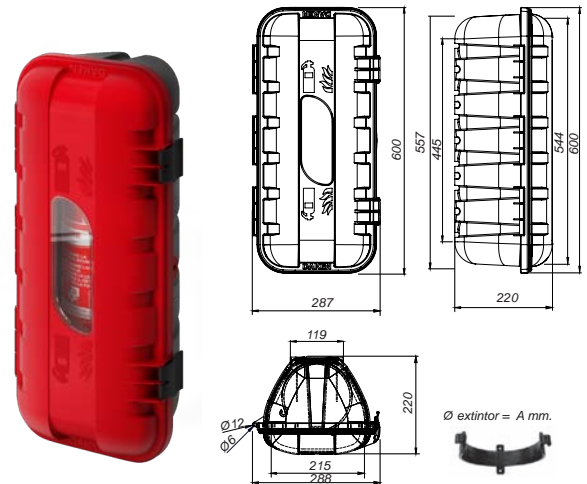

Homologated Fire Extinguisher Box 9/12Kg. STRIKE
Feuerlöscherkästen Anerkannt 9/12Kg. STRIKE
Cajón Extintor Homologado 9/12kg. STRIKE

NEW

Ref	Kg	Mat	Ø	Emark	Article	Part	Lot
0201160	2.3	PP	Ø190	E11	Box Assembled Cajón Montado	9 12 Kg	1
0201164	2.5	PP	Ø190	E11	Disassembled Full Pallet Desmontado Pallet Completo	9 12 Kg	80

Injection molding | Reinforcement ribs | Co-injected inspection window | nylon+PVC clamping spring | PVC seal | Lockable or sealable maximum security
Moldeo por inyección | Nervios reforzados | Visor de inspección | Kit bloqueo extintor (bayoneta) | Junta PVC | Posibilidad de insertar candado/sello
ECE Regulation 73.01

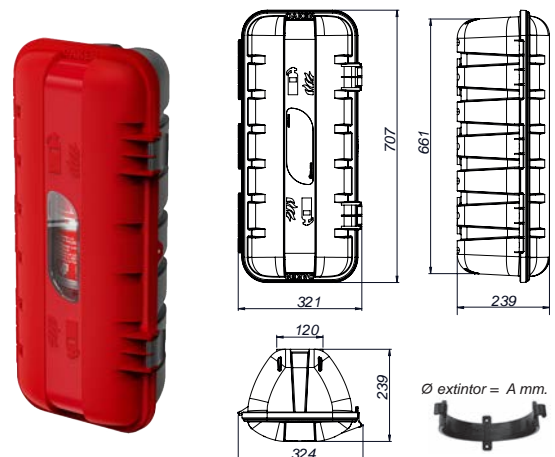

BOXES AND TANKS / WERKZEUGKÄSTEN UND WASSERTANKS / CAJONES Y BIDONES

FIRE EXTINGUISHER BOX / FEUERLÖSCHERKÄSTEN / CAJÓN EXTINTOR

ADABOX Bright Stainless Steel / *Inoxidable Brillo* (1,5 mm.)







- ✓ MATERIAL / MATERIAL:
 - Body-Cover / *Cuerpo-Tapa*:
Stainless Steel AISI 304/X5CrNi1 8-10/1,4301 2R/BA Bright
- ✓ SURFACE TREATMENT/ ACABADO
 - Body-Cover / *Cuerpo-Tapa*:
Stainless Steel AISI 304/X5CrNi1 8-10/1,4301 2R/BA Bright
- ✓ THICKNESS / ESPESOR:
 - Body / *Cuerpo*: 1.5 mm.
 - Cover / *Tapa*: 2 mm.
- ✓ HOMOLOGATION / HOMOLOGACIÓN:  ECE-R73.01
- ✓ PRODUCTION PROCESS: / PROCESO FABRICACIÓN:
Continuous welding / *Soldadura continua*

BOXES AND TANKS / WERKZEUGKÄSTEN UND WASSERTANKS / CAJONES Y BIDONES

Accessories <i>Accesorios</i>		Ref.	
●	Metallic hinge <i>Metallscharnier</i> Bisagra metálica	0298020	
●	Stainless Steel Lock <i>Edelsahl Verschluss</i> Cierre de Acero Inoxidable	1203002 1203003	
●	Rubber seal <i>Gummidichtung</i> Junta de goma	0298004	
●	Inspection Window <i>Inspektionsfenster</i> Ventana de Inspección	0298030	
●	Clamping Ring+Spring <i>Sicherungsring+Blockierfeder</i> Anillo+Correa	0298032	
●	Internal mat <i>Innentepich</i> Alfombrilla interior	-	
●	Brackets <i>Halterung</i> Soporte	0201498	





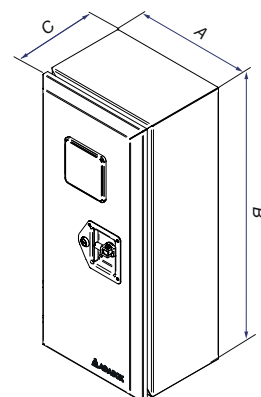

ADABOX Stainless Steel Bright Fire Extinguisher Box (1,5 mm.)
ADABOX Feuerlöscherkasten Edelstahl Poliert (1,5 mm.)
Cajón Extintor ADABOX Acero Inoxidable Brillo (1,5 mm.)

Ref	Kg	Mat	Sup/Finish Acabado	A	B	C	Thickn. Espesor	Key Llave	Part	Lock Type Cierre	Lot
0282232	13.6	INOX		300	700	240	1.5				1

With internal mat
Alfombrilla interior



ADABOX Stainless Steel Fire Extinguisher Bright Box (1,5 mm.), Double
ADABOX Feuerlöscherkasten Edelstahl Poliert (1,5 mm.), Doppelt
Cajón Extintor ADABOX Acero Inoxidable Brillo (1,5 mm.), Doble

Ref	Kg	Mat	Sup/Finish Acabado	A	B	C	Thickn. Espesor	Key Llave	Part	Lock Type Cierre	Lot
0282230	20.6	INOX		470	700	240	1.5				1

With internal mat
Alfombrilla interior

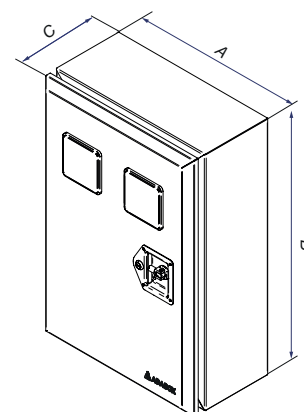

FIRE EXTINGUISHER ACCESSORIES / FEUERLÖSCHERSCHUBEHÖR / ACCESORIOS CAJÓN EXTINTOR



BOXES AND TANKS / WERKZEUGKÄSTEN UND WASSERTANKS / CAJONES Y BIDONES

Bracket (for Extinguisher Box 0201189/91/74)
 Halterung für Feuerlöscherkasten (für 0201189/91/74)
 Soporte de Cajón Extintor (0201189/91/74)

NEW

Ref	Kg	Mat	Sup/Finish Acabado	Thickn. Espesor	Strength Fuerza	Lot
0201500	1.8	STEEL	Zn	3	200 kg	1

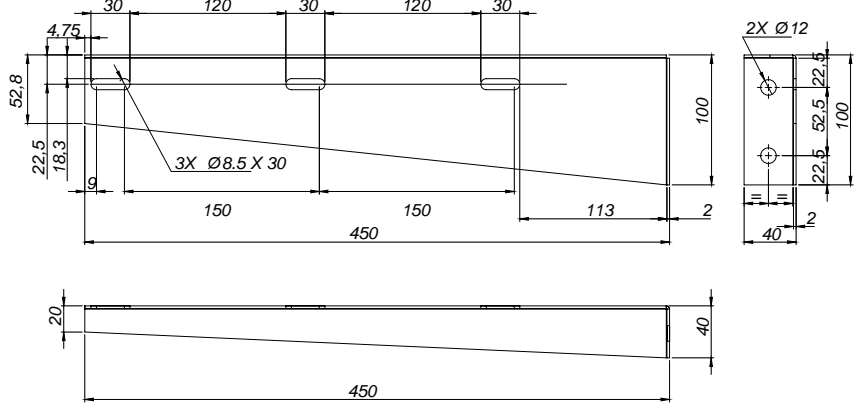

Bracket (for Extinguisher Box 0201192/95)
 Halterung für Feuerlöscherkasten (für 0201192/-95)
 Soporte de Cajón (0201192/95)

Ref	Kg	Mat	Sup/Finish Acabado	Col	Thickn. Espesor	Lot
0201495	3.6	STEEL		Black	3	1

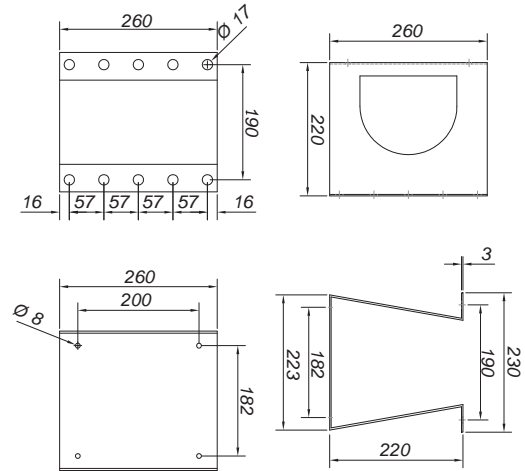

Bracket for Extinguisher Box (0201160/76/94/96/98)
 Halterung für Feuerlöscherkasten (0201160/76/94/96/98)
 Soporte de Cajón (0201160/76/94/96/98)

Ref	Kg	Mat	Sup/Finish Acabado	Thickn. Espesor	Lot
0201496	3.1	STEEL	Galv	3	1

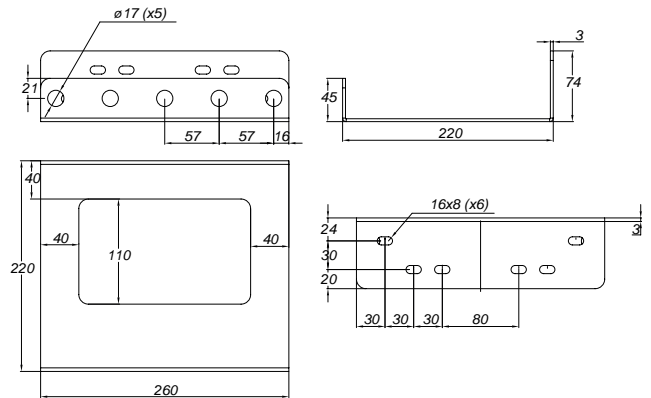

Inspection Window Ventana for ADABOX Fire Extinguisher
 Inspektionsfenster 110x110 für ADABOX Feuerlöscherkasten
 Ventana 110x110 Cajón Extintor ADABOX

NEW

Ref	Kg	Mat	Lot
0298030	0.08		1





FIRE EXTINGUISHER ACCESSORIES / FEUERLÖSCHERSCHZUBEHÖR / ACCESORIOS CAJÓN EXTINTOR

BOXES AND TANKS / WERKZEUGKÄSTEN UND WASSERTANKS / CAJONES Y BIDONES

Nylon Clamping Ring Ø150-170
Nylon Gummi Halter Ø150-170
Anillo Bloqueo Extintor Ø150-170 Nylon

Ref	Kg	Mat	Ø	Lot
0298012	0.3		Ø150-170	1



Nylon Clamping Ring Ø170-190
Nylon Gummi Halter Ø170-190
Anillo Bloqueo Extintor Ø170-190 Nylon

Ref	Kg	Lot
0298001	0.3	1



PVC Clamping Spring
Blockierfeder PVC
Correa de Sujeción PVC

Ref	Kg	Mat	Lot
0298002	0.02		1



Clamping Ring + Spring for ADABOX Extinguisher
Sicherungsring + Blockierfeder für ADABOX Feuerlöscher
Anillo Bloqueo+Correa p/Cajón Extintor ADABOX

NEW

Ref	Kg	Lot
0298032	0.32	1



ABC PP6HDI Fire Extinguisher 6Kg.
 ABC PP6HDI Feuerlöscher 6Kg.
 Extintor ABC PP6HDI 6Kg.

Ref	Kg	Cap.Kg	Article	Lot
7202106	9.77	6	34A - 233B - C	1

EN3 7 "N" AENOR. nº 012/002822 | PED 97/23 CE. Nº 01/SP/144. Type 1 | MI EXo 0375 V V



6Kg. Fire Extinguisher ABC PP6PS AFNOR-NF (France)
 Feuerlöscher 6Kg. ABC PP6PS AFNOR-NF (France)
 Extintor ABC PP6PS AFNOR-NF (Francia) 6Kg.

NEW

Ref	Kg	Cap.Kg	Article	Lot
7202114	9.77	6	27A - 144B - C	1

French label
 Etiqueta en francés
 AFNOR NF EN3 7 N° EP6 161 811 | Marine Marchande MED CE N° 15/SP/3688 / PED CE. Nº 01/SP/144.
 Type 1. / Transport



ABC PP6PS Fire Extinguisher 6Kg. (Portugal)
 ABC PP6PS Feuerlöscher 6Kg. (Portugal)
 Extintor ABC PP6PS 6Kg. (Portugal)

NEW

Ref	Kg	Cap.Kg	Article	Lot
7202110	9.5	6	27A - 183B - C	1

Portuguese label
 Etiqueta en portugués
 EN3 7 "N" AENOR. nº 012/002650 | PED 97/23 CE. Nº 01/SP/144. Type 1 | MI EXo 0375 V V



ABC PP9HDI Fire Extinguisher 9Kg.
 ABC PP9HDI Feuerlöscher 9Kg.
 Extintor ABC PP9HDI 9Kg.

Ref	Kg	Cap.Kg	Article	Lot
7202108	13.6	9	34A - 233B - C	1

EN3 7 "N" AENOR. nº 012/002743 | PED 97/23 CE. Nº 01/SP/144. Type 1 | MI EXo 0377 VI V



BOXES AND TANKS / WERKZEUGKÄSTEN UND WASSERTANKS / CAJONES Y BIDONES



FIRE EXTINGUISHERS / FEUERLÖSCHER / EXTINTORES

BOXES AND TANKS / WERKZEUGKÄSTEN UND WASSERTANKS / CAJONES Y BIDONES

ABC PP9HDI Fire Extinguisher 9Kg. (Portugal)
ABC PP9HDI Feuerlöscher 9Kg. (Portugal)
Extintor ABC PP9HDI 9Kg. (Portugal)

NEW



Ref	Kg	Cap.Kg	Article	Lot
7202112	13.5	9	34A - 233B - C	1

Portuguese label
Etiqueta en portugués
EN3 7 "N" AENOR. nº 012/003119 | PED 97/23 CE. Nº 01/SP/144. Type 1 | MI Exo 0377 V V

Fire extinguisher ABC 2Kg. PS3-HX
Feuerlöscher ABC 2Kg. PS3-HX
Extintor ABC 2Kg. PS3-HX

NEW



Ref	Kg	Cap.Kg	Article	Lot
79610005	4.8	3	13A - 89B - C	1

EN 3/7 y 97/23/EC y 96/98/EC

Fire extinguisher ABC 2Kg. PS2
Feuerlöscher ABC 2Kg. PS2
Extintor ABC 2Kg. PS2

NEW



Ref	Kg	Cap.Kg	Article	Lot
79610003	2.55	2	13A 89B - C	1

EN 3/7 y 97/23/EC y 96/98/EC

2Kg. Fire Extinguisher ABC PP2P AFNOR-NF (France)
Feuerlöscher 2Kg. ABC PP2P AFNOR-NF (France)
Extintor BC PP2P AFNOR-NF (Francia) 2Kg.

Ref	Kg	Ø	Article	Lot
7202102	4.1	Ø100-106	13A - 89B - C	1

French label
Etiqueta en francés
AFNOR NF EN3 7 N° EP2 156 626 | Transport | PED 97/23 CE. Nº 01/SP/372. Type 4



Fire Extinguisher Support 6Kg.
 Feuerlöscherhalterung 6Kg.
 Soporte Extintor 6Kg.

Ref	Kg	Mat	Sup/Finish Acabado	Lot
7202123	0.58	STEEL	Zn	1

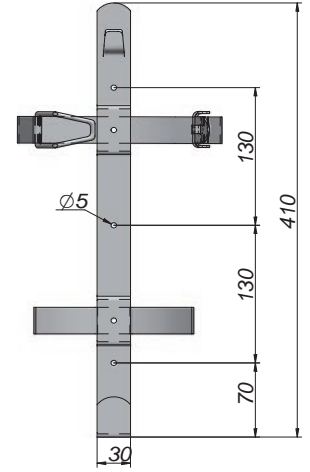
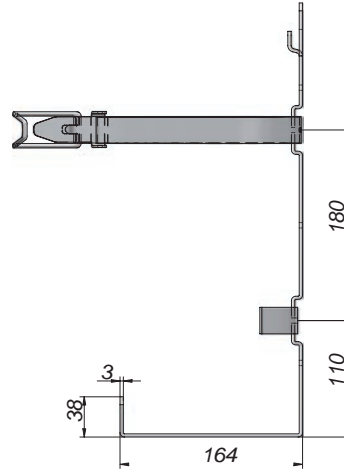

Fire Extinguisher Support 9Kg.
 Feuerlöscherhalterung 9Kg.
 Soporte Extintor 9Kg.

Ref	Kg	Mat	Sup/Finish Acabado	Lot
7202125	0.82	STEEL	Zn	1

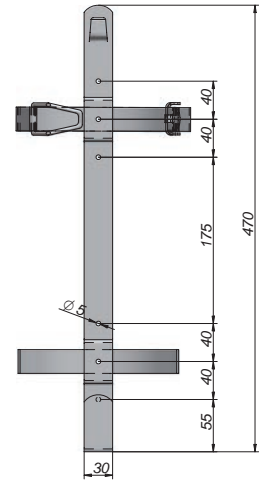
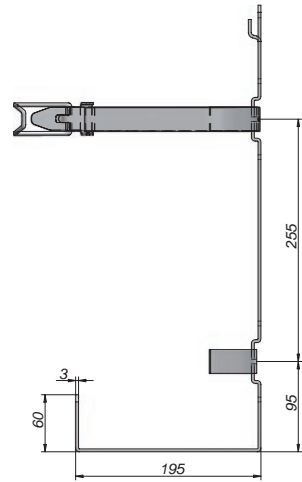

BOXES AND TANKS / WERKZEUGKÄSTEN UND WASSERTANKS / CAJONES Y BIDONES



TANKS / WASSERTANKS / BIDONES

BOXES AND TANKS / WERKZEUGKÄSTEN UND WASSERTANKS / CAJONES Y BIDONES



BIDONES TANKS

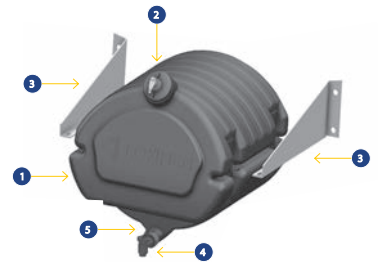

COMPONENTES / COMPOSANTS

- 1 - Tank / Depósito
- 2 - Soap dispenser-cap / Jabonera-Tapón
- 3 - 2 Brackets kit / Kit 2 soportes
- 4 - Tap / Grifo
- 5 - Clamping ring / Anillo de refuerzo

MATERIAL: High Density Polyethylene (HDPE)

PRODUCTION PROCESS: Injection blow molding

TEST: Test: Resistant to the use of alcohol-based additives

TIGHTNESS

WIDE RANGE OF ACCESSORIES: Supports, caps, soapholder, dispensers...



MATERIAL: Polietileno Alta Densidad (HDPE)

PROCESO FABRICACIÓN: Soplado-Inyección

TEST: Resistentes al uso de aditivos basados en alcohol

ESTANQUEIDAD

AMPLIA GAMA DE ACCESORIOS: Soportes, tapones, jaboneras, dosificadores...

Tank 50l. w/Soap Holder
 Wassertank 50l. Kunststoff m/Seifenhalter m/Hahn
 Bidón Plástico 50l. c/Portajabon c/Grifo

Ref	Kg	Mat	Col	Cap.L	Lot
2001455	3.65	PE	●	50	1

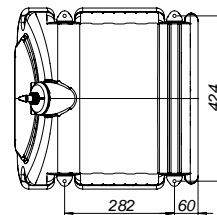
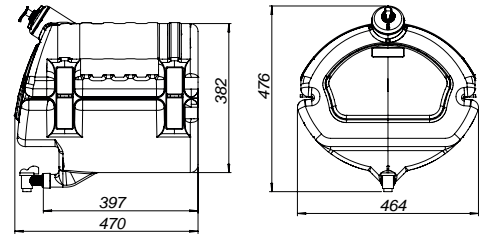

2 Tank Support Kit 50l. Zinc Plated 2001455
 2 Halterungen Verzinkt f. 50l. Tank 2001455
 Kit 2 Soportes Bidón 50l. Acero Cincado 2001455

Ref	Kg	Mat	Sup/Finish Acabado	Thickn. Espesor	Lot
2001456	3.4	STEEL	Zn	4	1

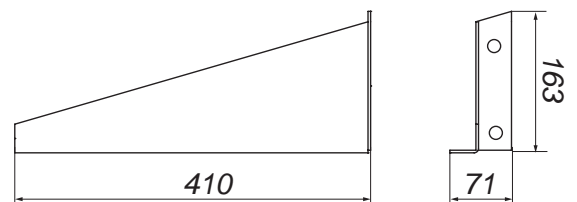



Plastic Tank 30l. White w/Cap w/Tap
 Wassertank 30l. Kunststoff Weiss m/Deckel m/Hahn
 Bidón Plástico 30l. Blanco c/Tapón c/Grifo

Ref	Kg	Mat	Col	Cap.L	Lot
2001442	2.9			30	1

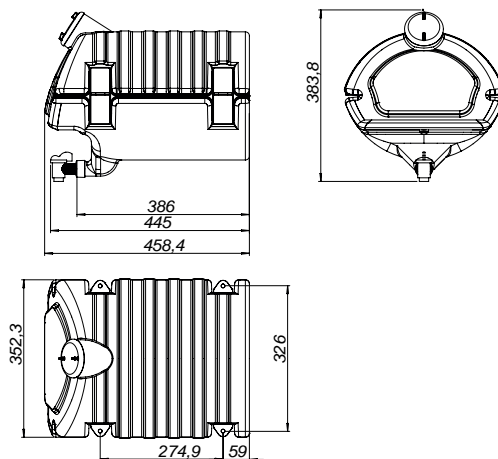

Plastic Tank 30l. Black w/Cap w/Tap
 Wassertank 30l. Kunststoff Schwarz m/Deckel m/Hahn
 Bidón Plástico 30l. Negro c/Tapón c/Grifo

Ref	Kg	Mat	Col	Cap.L	Lot
2001443	2.9			30	1

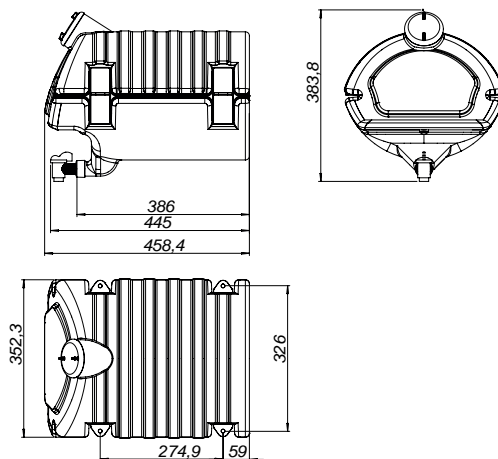

Plastic Tank 30l. Black w/Soap Holder
 Wassertank 30l. Kunststoff Schwarz m/Seifenspender m/Hahn
 Bidón Plástico 30l. Negro c/Portajabon c/Grifo

Ref	Kg	Mat	Col	Cap.L	Lot
2001447	2.95			30	1

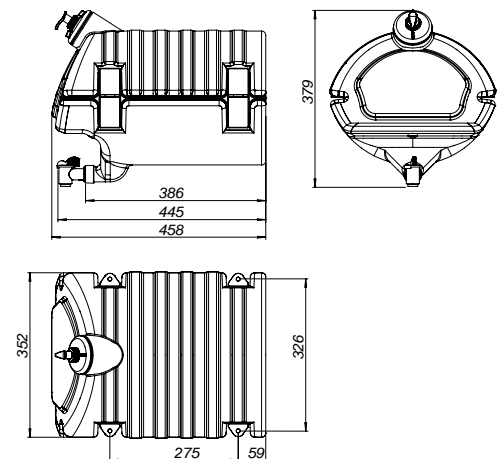

2 Tank Support Kit 30l. (for 2001442/43/47)
 2 Halterungen Verzinkt f. 30l.-Tank (für 2001442/43/47)
 Kit 2 Soportes Bidón 30l. para 2001442/43/47

Ref	Kg	Mat	Sup/Finish Acabado	Thickn. Espesor	Lot
2001544	2.5	STEEL	Zn	3	1

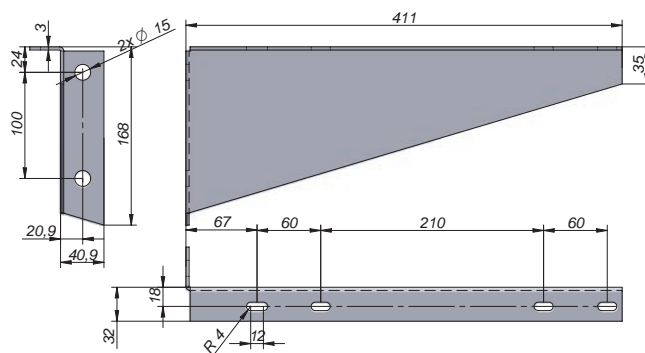



TANKS / WASSERTANKS / BIDONES

BOXES AND TANKS / WERKZEUGKÄSTEN UND WASSERTANKS / CAJONES Y BIDONES

Tank Plastic Black 18l. with Soap Holder
Wassertank 18l. Kunststoff Schwarz m/Seifenspender
Bidón Plástico 18l. Negro c/Portajabón

Ref	Kg	Mat	Col	Cap.L	Lot
2001462	1.9			18	1

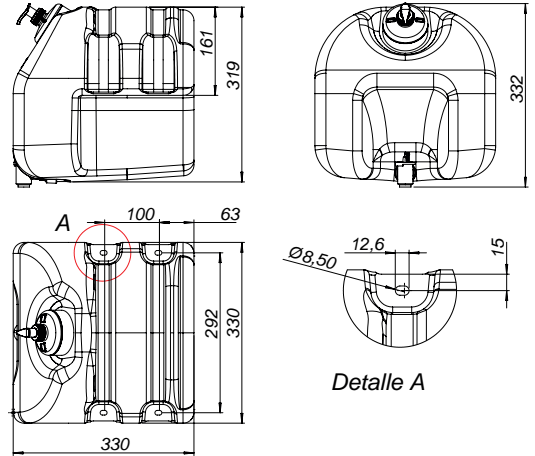

2 Tank Support Kit for 2001462 Zinc Plated
2 Halterungen Verzinkt für 2001462
Kit 2 Soportes para Bidón 2001462 Acero Cincado

Ref	Kg	Mat	Pos	Lot
2001549	1.53			1

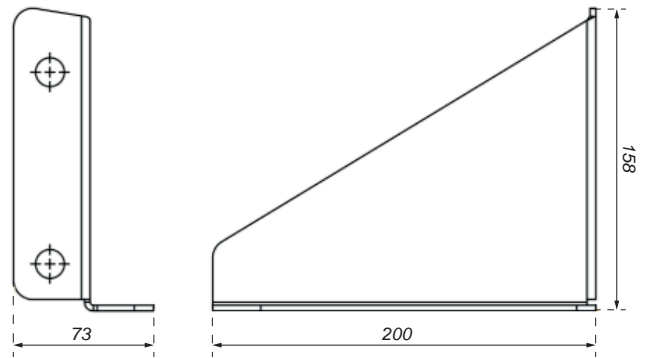

Tank Plastic Black 30l. with Soap Holder
Wassertank 30l. Kunststoff Schwarz m/Seifenspender
Bidón Plástico 30l. Negro c/Portajabón

Ref	Kg	Mat	Col	Cap.L	Thread Rosca	Lot
2001460	2.15			30	M25x1.5 mm	1

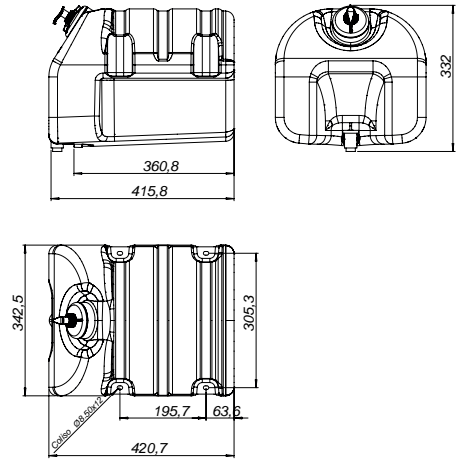

Tank Horizontal Support Kit f/2001460
Halterung Horizontal für Tank 2001460
Kit Soportes para Bidón 2001460

Ref	Kg	Mat	Pos	Lot
2001547	3.22			1

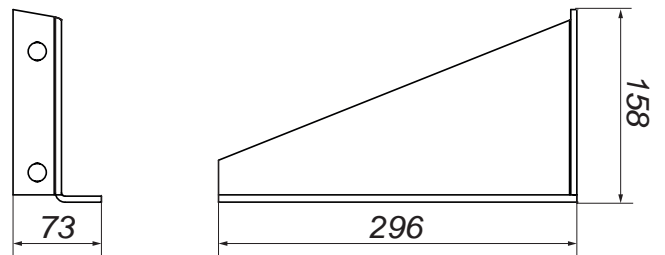
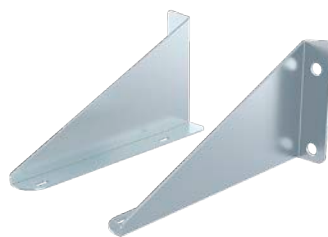

Plastic Tank Cap
Tankdeckel Kunststoff f. Tank
Tapón para Bidón

Ref	Kg	Mat	Col	Lot
2001563	0.07	PP	Black	1
2001565	0.07	PP	White	4

2001563



2001565



Plastic Tap for Tank 2001442/43/47/55/60/62/34/35/36/38
Wasserhahn Kunststoff f. Tank 2001442/43/47/55/60/62/34/35/36/38
Grifo Plástico p/Bidón 2001442/43/47/55/60/62/34/35/36/38

Ref	Kg	Mat	Col	Lot
2001584	0.02	PP	Black	1
2001585	0.01	PP	White	1

2001584



2001585

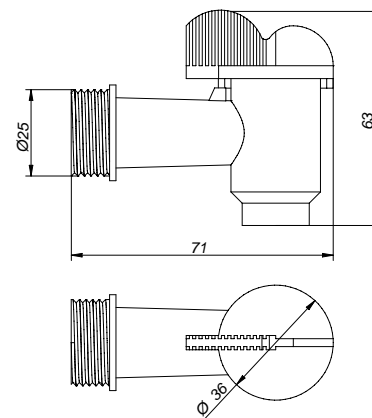

Plastic Soapholder Black
Seifenspender Kunststoff Schwarz
Portajabón Plástico Negro

Ref	Kg	Mat	Cap.L	Lot
2001568	0.06	PP	0.25	1



Push-Button
Pumpe f. Seifenspender
Pulsador/Dosificador

Ref	Kg	Mat	Lot
2001570	0.02	PP	4





TANKS / WASSERTANKS / BIDONES

BOXES AND TANKS / WERKZEUGKÄSTEN UND WASSERTANKS / CAJONES Y BIDONES

Plastic Tank 25l.
Wassertank 25l. Kunststoff
Bidón 25l. Plástico

Ref	Kg	Mat	Cap.L	Lot
2001434	1.25		25	1

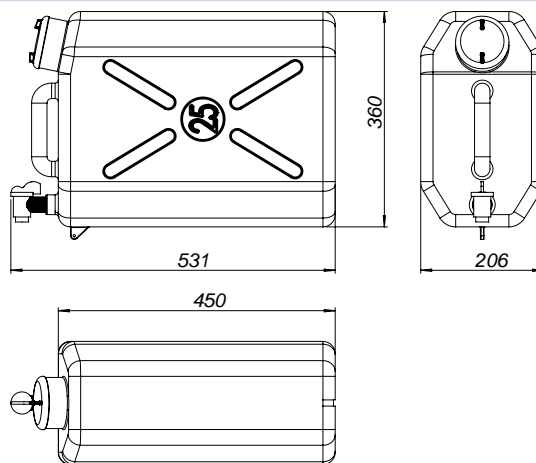

Plastic Tank 25l. with Soap Holder
Wassertank 25l. Kunststoff mit Seifenspender
Bidón 25l. Plástico c/Portajabón

Ref	Kg	Mat	Cap.L	Lot
2001435	1.25		25	1

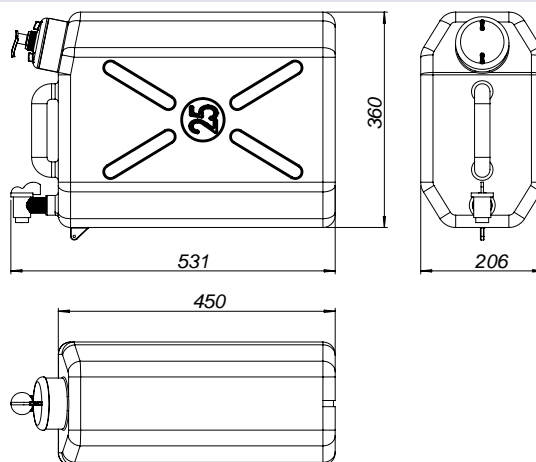

Plastic Tank 25l. w/zinc plated Support
Wassertank 25l. Kunststoff m/ Halter verz.
Bidón 25l. Plástico c/Soporte Cincado

Ref	Kg	Mat	Cap.L	Key Llave	Lot
2001436	6.05		25		1

Includes security lock with keys
Incluye candado con llaves

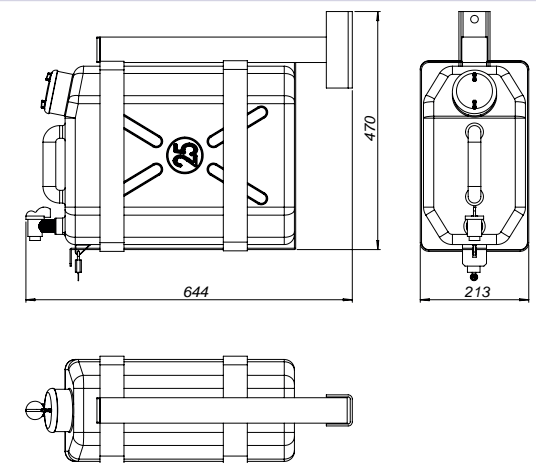

Plastic Tank 25l. with Support with Soapholder
Wassertank 25l. Kunststoff m/Seifenspender m/Halter Verzinkt
Bidón 25l. Plástico c/Soporte Cincado c/Portajabón

Ref	Kg	Mat	Cap.L	Key Llave	Lot
2001438	6.05		25		1

Includes padlock with keys
Incluye candado con llaves

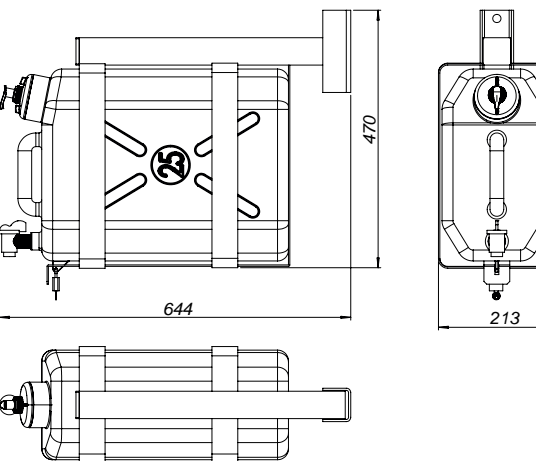

Plastic Tank 25l.
Wasserkanister 25l. Kunststoff
Bidón 25l. Plástico

Ref	Kg	Mat	Cap.L	Lot
2001445	6		25	1

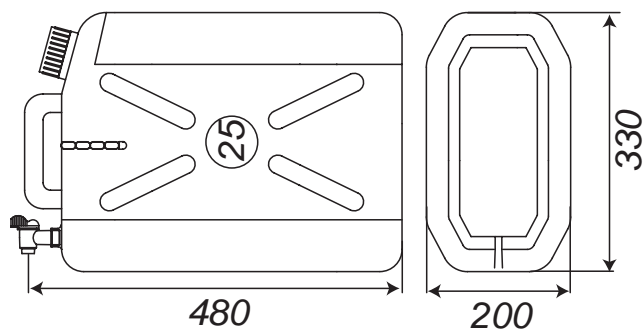

Plastic Tank 25l. w/zinc plated Support
Tank 25l. Plastik m/Verzinkt Halter
Bidón 25l. Plástico c/Soporte Cincado

Ref	Kg	Mat	Cap.L	Lot
2001446	6.5		25	1

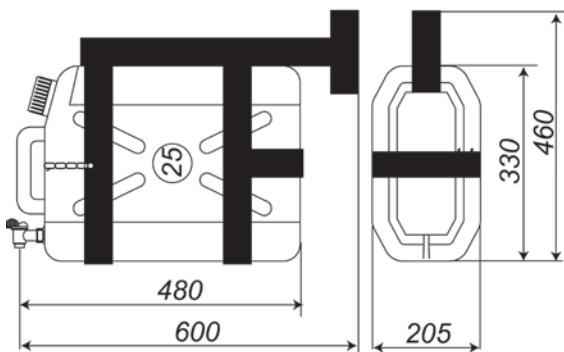

Tank Clamp 30l. 150R Galvanized Steel
Halteband für 30l.-Tank, r=150 Stahl Feuerverzinkt
Brida Bidón 30l. 150R Galvanizado

Ref	Kg	Mat	Sup/Finish Acabado	Thickn. Espesor	Lot
2001520	0.19	STEEL	Galv	1.5	4

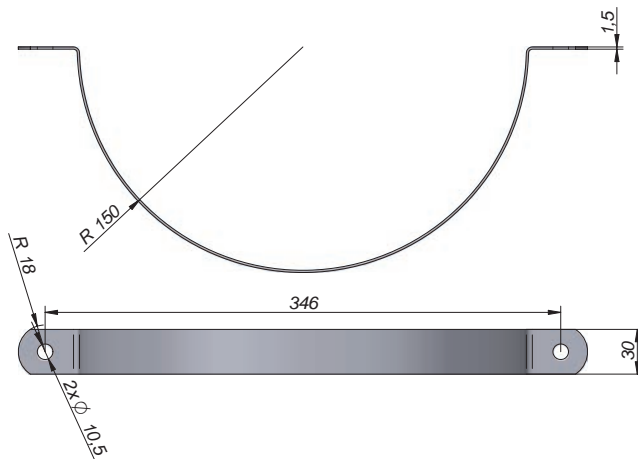

Plastic Tank Cap Ø61X25
Tankdeckel Ø61X25 Kunststoff
Tapón Bidón Ø61X25 Plástico

Ref	Kg	Mat	Col	Lot
2001559	0.03			4

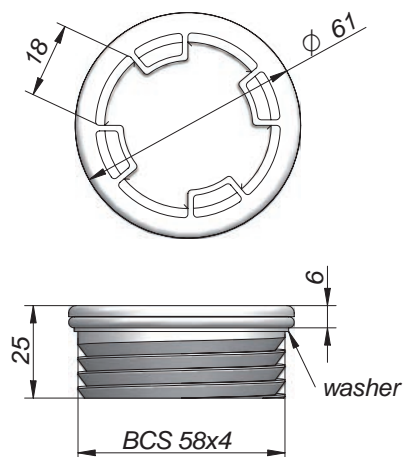

Plastic Tap Tank White
Wasserhahn Kunststoff f. Tank Weiss
Grifo Plástico Blanco

Ref	Kg	Mat	Lot
2001580	0.02	PE	10

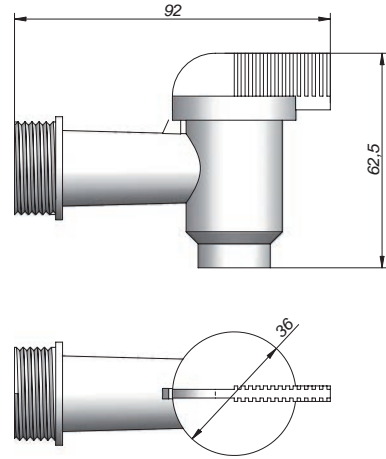

Tank 12l. 170x180x410 Stainless Steel
Wassertank Edelstahl 12l. 170x180x410
Bidón 12l. 170x180x410 Inox

Ref	Kg	Mat	Thickn. Espesor	Cap.L	Lot
2001487	3	INOX	0.8	12	1

Stainless Steel AISI 304/X5CrNi18-10/1.4301-2R/Z7CN18-9 |
Finish: 2B | TIG welding, qualified process
Acero Inoxidable AISI 304/X5CrNi18-10/1.4301-2R/Z7CN18-9 |
Acabado: 2B | Soldadura TIG proceso cualificado

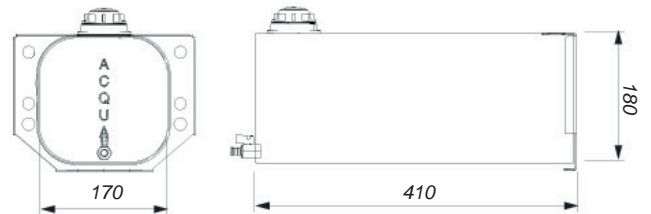

Tank 25l. 170x360x400 Stainless Steel
Wassertank Edelstahl 25l. 170x360x400
Bidón 25l. 170x360x400 Inox

Ref	Kg	Mat	Thickn. Espesor	Cap.L	Lot
2001488	5.3	INOX	0.8	25	1

Stainless Steel AISI 304/X5CrNi18-10/1.4301-2R/Z7CN18-9 |
Finish: 2B | TIG welding, qualified process
Acero Inoxidable AISI 304/X5CrNi18-10/1.4301-2R/Z7CN18-9 |
Acabado: 2B | Soldadura TIG proceso cualificado

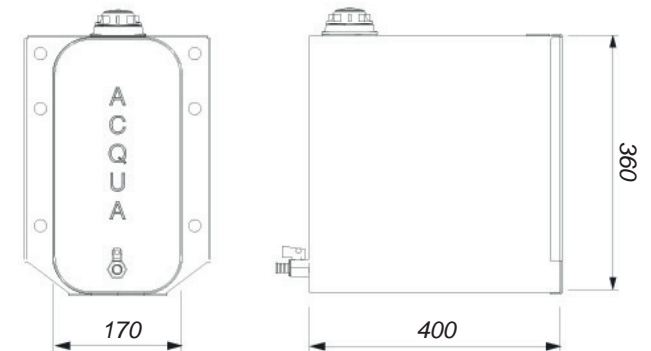

Tank 25l. 280x250x370 Stainless Steel
Wassertank Edelstahl 25l. 280x250x370
Bidón 25l. 280x250x370 Inox

Ref	Kg	Mat	Thickn. Espesor	Cap.L	Lot
2001486	4.35	INOX	0.8	25	1

Stainless Steel AISI 304/X5CrNi18-10/1.4301-2R/Z7CN18-9 |
Finish: 2B | TIG welding, qualified process
Acero Inoxidable AISI 304/X5CrNi18-10/1.4301-2R/Z7CN18-9 |
Acabado: 2B | Soldadura TIG proceso cualificado

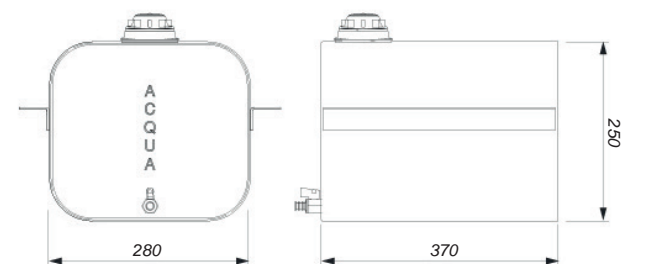



PVC Soapholder for 2001486/87/88
 Seifenspender PVC für 2001486/87/88
 Portajabón PVC p/2001486/87/88

Ref	Kg	Mat	Col	Cap.L	Article	Lot
2001569	0.05			0,250 l.	T. A TIPO A	1



Tap for Stainless Steel Tank 2001486/87/88
 Wasserhahn für Tank Edelstahl 2001486/87/88
 Grifo para Bidón Inox 2001486/87/88

NEW

Ref	Kg	Mat	Lot
2001586	0.04		1





HOSE TUBE HOLDER / SCHLAUCHROHRBEHÄLTER / PORTAMANGUERAS

BOXES AND TANKS / WERKZEUGKÄSTEN UND WASSERTANKS / CAJONES Y BIDONES

Cover for Hose Tube Holder Single with key
Klappe 1-Fach für Schlauchrohrbehälter mit Schlüssel
Tapa Portamangueras Simple c/llave



Ref	Kg	Mat	Ø	Llave Con Llave	Lot
0201010	1		Ø160		1
0201020	0.62		Ø200		1

Endcap for Hose Tube Holder Single
Endkappe 1-Fach für Schlauchrohrbehälter
Tapón Portamangueras Simple



Ref	Kg	Mat	Ø	Lot
0201012	0.13		Ø160	2
0201022	0.18		Ø200	2

Cover for Hose Tube Holder Double with key
Klappe 2-Fach für Schlauchrohrbehälter mit Schlüssel
Tapa Portamangueras Doble c/llave



Ref	Kg	Mat	Ø	Llave Con Llave	Lot
0201014	0.77		Ø160		1
0201024	0.99		Ø200		1

Endcap for Hose Tube Holder Triple
Endkappe 3-Fach für Schlauchrohrbehälter
Tapón Portamangueras Triple



Ref	Kg	Mat	Ø	Lot
0201019	0.36		Ø160	2
0201029	0.54		Ø200	2

Cover for Hose Tube Holder Triple with key
Klappe 3-Fach für Schlauchrohrbehälter mit Schlüssel
Tapa Portamangueras Triple c/llave



Ref	Kg	Mat	Ø	Llave Con Llave	Lot
0201018	1.02		Ø160		1
0201028	1.46		Ø200		1

Endcap for Hose Tube Holder Double
Endkappe 2-Fach für Schlauchrohrbehälter
Tapón Portamangueras Doble



Ref	Kg	Mat	Ø	Lot
0201016	0.24		Ø160	2
0201026	0.36		Ø200	2



Tableros-Chasis

Plywood Boards-Chassis

Contreplaqué

Holzplatten-Fahrgestell

Contraplacado-Chassis



Tableros
Plywood Boards
Contreplaqués
Bodenplatten
Contraplacado

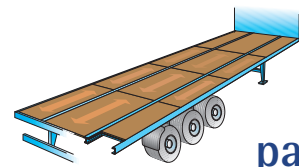

pag. 140-141

Soporte de Chasis
Chassis Bracket
Support de Chassis
Chassis-Zubehör
Suporte Chassis

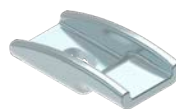

pag. 142-144

Contenedor
Container
Conteneur
Container
Contentor



pag. 145-149

Escaleras
Ladders
Escaliers
Leitern
Escadas



pag. 150-155

Paragolpes Trasero
Bumpers
Pare-Choc Arrière
Heckstossfänger
Para-Choques Traseiro

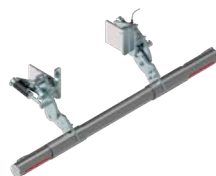

pag. 156-163

Paragolpes Lateral
Side Anti Crash
Pare-Choc Latéral
Seitliche Schutzvorrichtung
Para-Choques Lateral

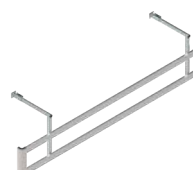
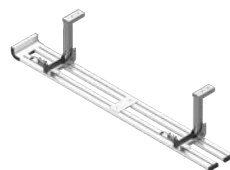

pag. 164-173

Tope Paragolpes
Bumper end Cap
Butoirs à Ressorts
Gummirammspuffer
Batente

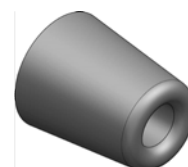
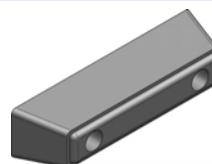

pag. 174-180

Tope Rodillo
Rubber Rolling Bumper
Butoirs à Roule
Rollrammpuffer
Batente Rolo



pag. 181-183

Tops Metálicos
Metal Bumpers
Butoirs Métalliques
Metalpuffer
Batentes Metálicos



pag. 184

Birch Plywood WIRE
 Birke Schichtholzplatten WIRE
 Tablero de Abedul WIRE

Ref	Kg	A	B	C	D	Lot
0301610	23.26	1525	2500	9	7	1
0301612	31.26	1525	2500	12	9	1
0301615	34	1525	2200	15	11	1
0301614	38.89	1525	2500	15	11	1
0301617	40.93	1525	2200	18	13	1
0301616	46.51	1525	2500	18	13	1
0301618	54.52	1525	2500	21	15	1
0301620	62.14	1525	2500	24	17	1
0301622	70.15	1525	2500	27	19	1
0301628	77.78	1250	3050	30	21	1
0301624	77.78	1525	2500	30	21	1
0301626	94.89	1525	3050	30	21	1

Plywood coated with 120Y-220 g/m2 phenolic film. It has a mesh working surface with wearing capacity of 400-Y550 Taber test rotations.

Contrachapado 100% abedul recubierto de 120-220 g/m2 película fenólica | Superficie de malla con capacidad de uso de 400-550 (test de desgaste TABER) | EN 13986:2004 | FSC Certificate (Forest Stewardship Council) | VIT Product certificate

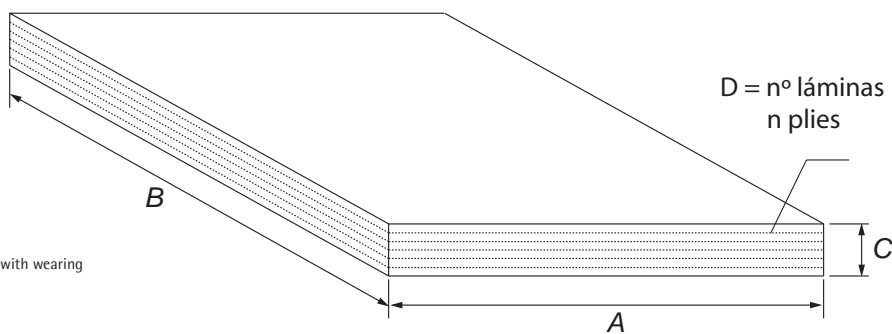

Birch Plywood BIRCH BB/CP
 Birke Schichtholzplatten BIRCH BB/CP
 Tablero de Abedul BIRCH BB/CP

Ref	Kg	A	B	C	D	Lot
0301430	44	1250	2500	21	15	1
0301432	50.69	1250	2500	24	17	1
0301434	57.07	1250	2500	27	19	1

100% sanded birch plywood non overlaid

Contrachapado 100% abedul lijado sin recubrimiento | EN 13986:2004 | FSC Certificate (Forest Stewardship Council) | VIT Product certificate

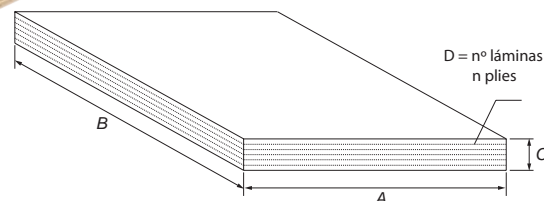

Birch Plywood KoskiDeck
 Birke Schichtholzplatten KoskiDeck
 Tablero Abedul KoskiDeck

Ref	Kg	A	B	C	Lot
0301238	24.02	1525	2500	9	1
0301240	32.03	1525	2500	12	1
0301241	35.23	1525	2200	15	1
0301242	40.03	1525	2500	15	1
0301243	42.27	1525	2200	18	1
0301244	48.04	1525	2500	18	1
0301246	56.04	1525	2500	21	1
0301248	64.05	1525	2500	24	1
0301249	72.06	1525	2500	27	1
0301250	80.06	1525	2500	30	1
0301272	80.06	1250	3050	30	1
0301270	97.68	1525	3050	30	1
0301276	101.63	1525	3400	28	1
0301278	108.89	1525	3400	30	1

Coating: film (120-440) | Bonding: Phenolic resin (EN314-2/clase3) | Density: 700 kg/m3 | Test Taber 300-1500R (EN438-2); Wheel 4000 (SFS3939)

Recubrimiento: film (120-440) | Encolado: Resina fenólica (EN314-2/clase3) | Densidad: 700 kg/m3 | Test Taber 300-1500R (EN438-2); Rodadura 4000 (SFS3939) | E17 118R11 Type Approved | 95/28/EC Approval for vehicle floors | EN 13501-1 Class Bfl-s1 for floors (e>9 mm.)

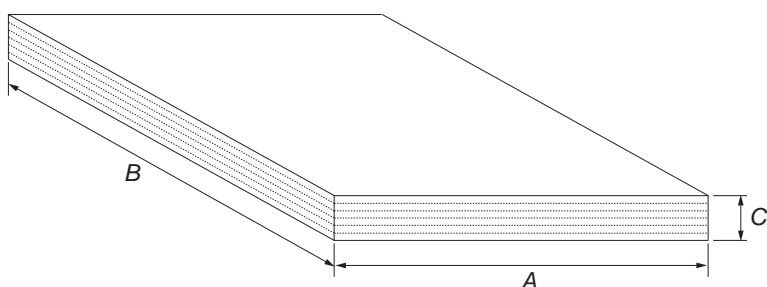
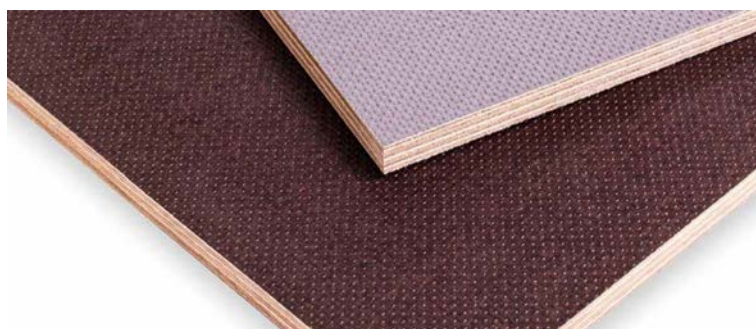

Trailer Floor Installation

Instalación de suelos para Remolques

LONGITUDINAL INSTALLATION
INSTALACION LONGITUDINAL

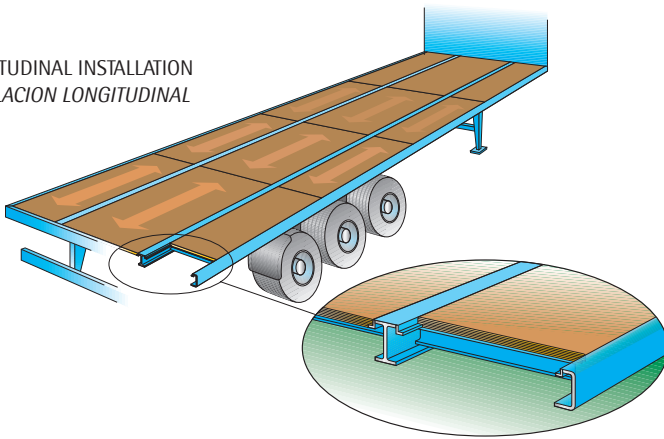

*Special oriented plywood construction recommended
Orientación especial de los tableros - construcción recomendada



TRANSVERSE INSTALLATION, OPTION 1
INSTALACION TRANSVERSAL, OPCION 1

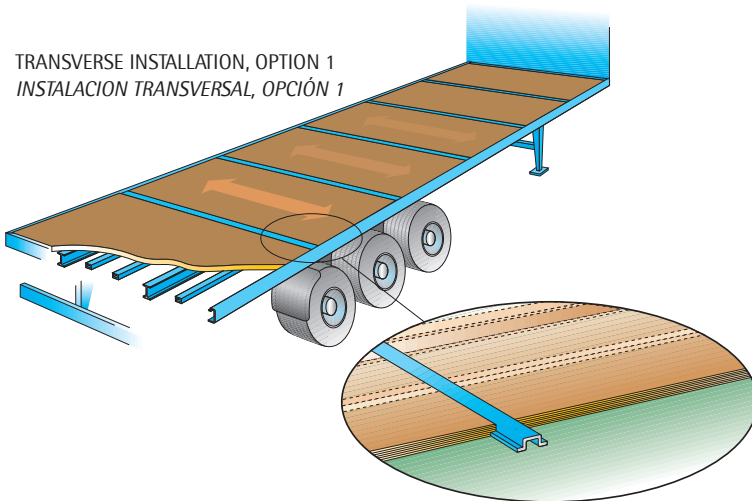

*Special oriented plywood construction recommended
Orientación especial de los tableros - construcción recomendada

TRANSVERSE INSTALLATION, OPTION 2
INSTALACION TRANSVERSAL, OPCION 2

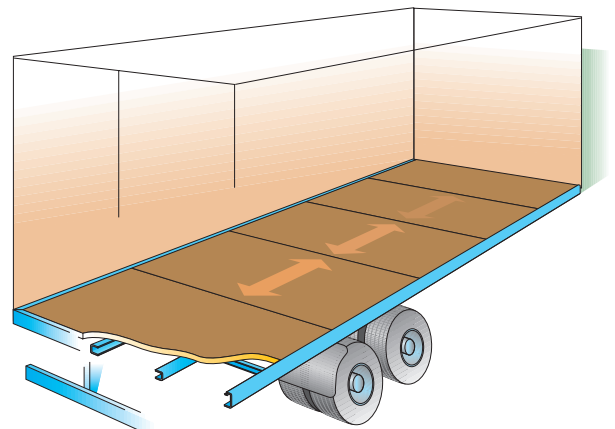

*Standard plywood construction recommended
Orientación estándar de los tableros - construcción recomendada

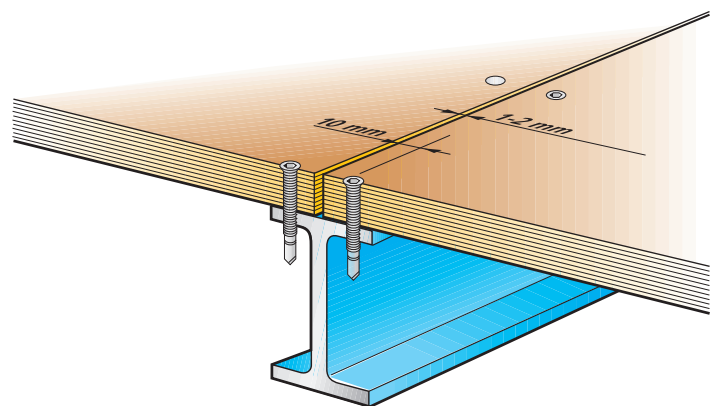
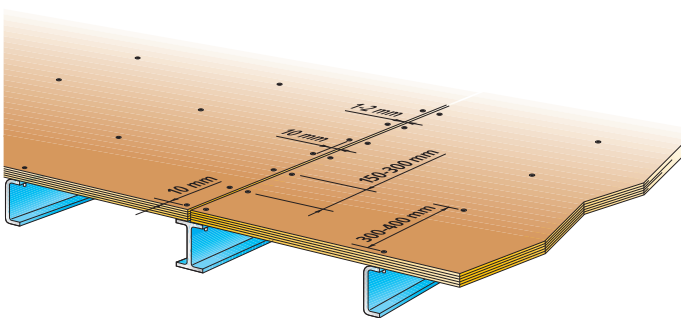

- Spacing between screws 150–300 mm near to the joint and elsewhere 300–400 mm.
- The distance from the edge of the screw head to the panel edge is minimum 10 mm.
- Acid proof screws to be used
- Protect the screw-heads after installation with sealing compound

- Distancia entre tornillos 150 a 300 mm. cerca de la articulación y en otros lugares 300 a 400 mm.
- La distancia desde el borde de la cabeza del tornillo hasta el borde del panel es 10 mm mínimo.
- Utilizar tornillos a prueba de ácido.
- Proteger las cabezas de tornillos después de la instalación con un compuesto de sellado.



CHASSIS BRACKET / KLEMMPRATZEN & FAHRGESTELLBÖCKCHEN / SOPORTE DE CHASIS

PLYWOOD BOARDS-CHASSIS / BODENPLATTEN-FAHRGESTELLZUBEHÖR / TABLEROS-CHASIS

Chassis Bracket 130x72x30
Klemmpratze 130x72x30
Soporte Fijación Chasis 130x72x30

Ref	Kg	Mat	Sup/Finish Acabado	Lot
2001012	1.1	STEEL	Zn	10

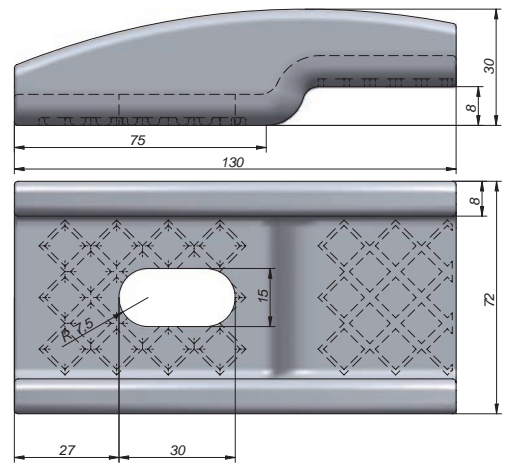
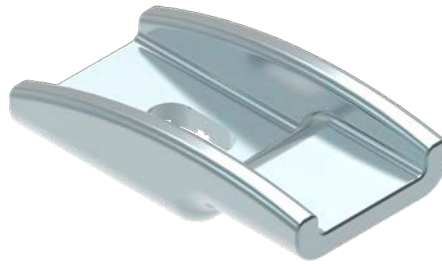

Chassis Bracket 125x50x20
Klemmpratze 125x50x20
Soporte Fijación Chasis 125x50x20

Ref	Kg	Mat	Sup/Finish Acabado	Lot
2001015	0.66	STEEL	Zn	6

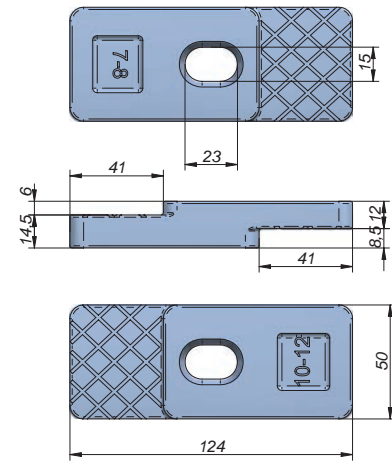
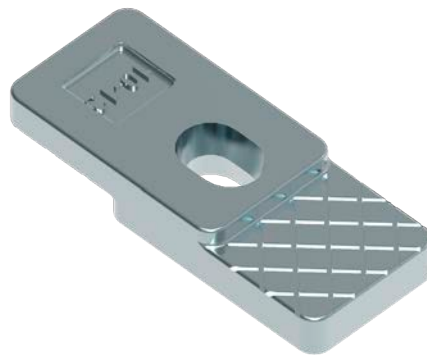

Zinc Plated Chassis Bracket 54x30 with Washer
Klemmpratze Verzinkt 54x30 mit Unterlegscheibe
Fijación de Chasis 54x30 Cincado c/arandela

NEW

Ref	Kg	Mat	Sup/Finish Acabado	Lot	Pack
2001070	0.72	STEEL	Zn	1	4

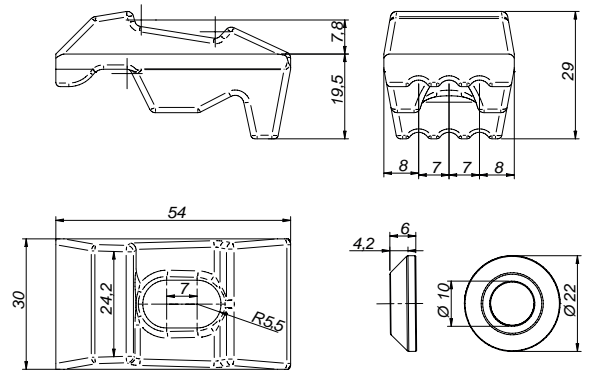

Galvanized Steel Chassis Bracket 80x36 with Washer
Klemmpratze Feuerverzinkt 80x36 mit Unterlegscheibe
Fijación de Chasis 80x36 Galvanizado c/arandela

NEW

Ref	Kg	Mat	Sup/Finish Acabado	Lot	Pack
2001072	0.64	STEEL	Galv	1	2

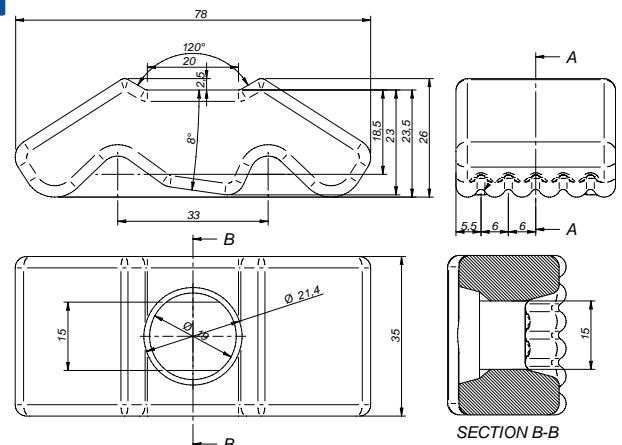

CHASSIS BRACKET / KLEMMPRATZEN & FAHRGESTELLBÖCKCHEN / SOPORTE DE CHASIS



PLYWOOD BOARDS-CHASSIS / BODENPLATTEN-FAHRGESTELLZUBEHÖR / TABLEROS-CHASIS

U Chassis Bracket Steel 115x66x60 e=5
 Chassis-Böckchen 115x66x60 e=5
 Soporte Chasis U Acero 115x66x60 e=5

Ref	Kg	Mat	Thickn. Espesor	Lot
2001020	0.32	STEEL	5	50

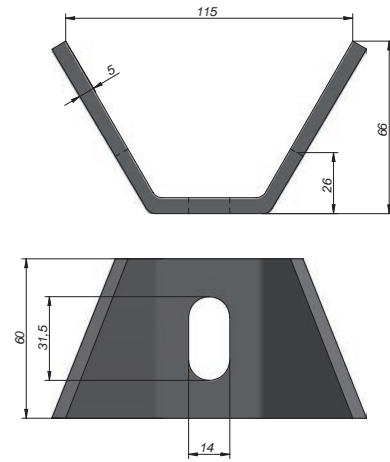
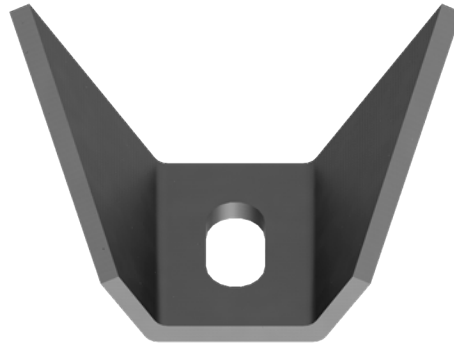

U Chassis Bracket Steel 147x82x60 e=6
 Chassis-Böckchen Stahl 147x82x60 e=6
 Soporte Chasis U Acero 147x82x60 e=6

Ref	Kg	Mat	Thickn. Espesor	Lot
2001022	0.43	STEEL	6	20

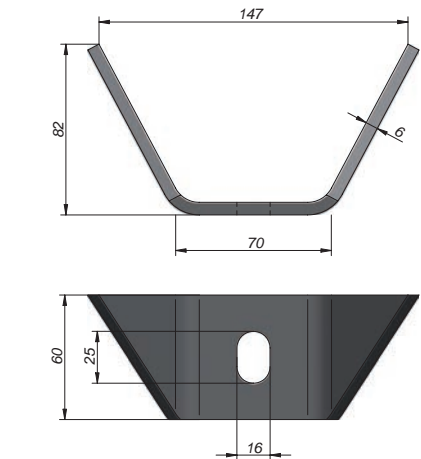

U Chassis Bracket Steel 114x115x60 e=6
 Chassis-Böckchen Stahl 114x115x60 e=6
 Soporte Chasis U Acero 114x115x60 e=6

Ref	Kg	Mat	Thickn. Espesor	Lot
2001024	0.69	STEEL	6	10

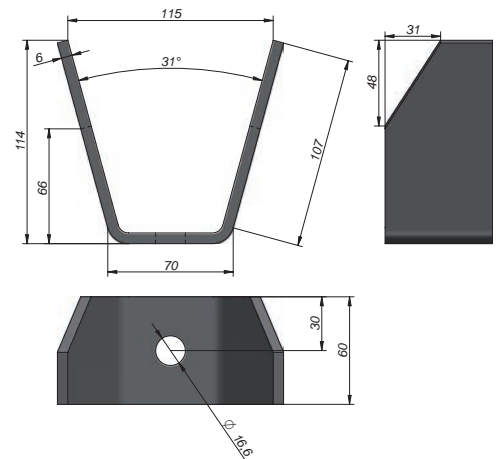

Chassis Bracket Steel 84x90x50 e=4
 Chassis-Böckchen Stahl 84x90x50 e=4
 Fijación Chasis Acero 84x90x50 e=4

Ref	Kg	Mat	Sup/Finish Acabado	Thickn. Espesor	Lot
2001030	0.37	STEEL		4	50
2001032	0.32	STEEL	Zn	4	10

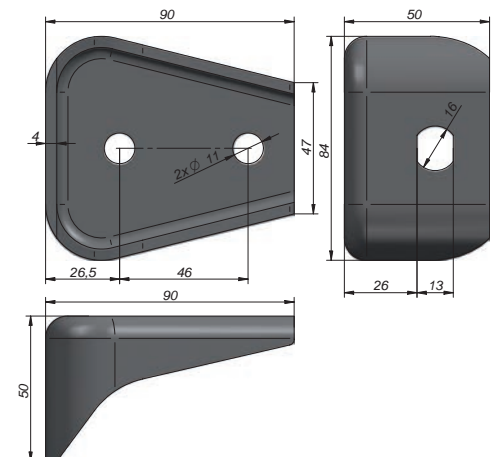



CHASSIS BRACKET / KLEMMPRATZEN & FAHRGESTELLBÖCKCHEN / SOPORTE DE CHASIS

PLYWOOD BOARDS-CHASSIS / BODENPLATTEN-FAHRGESTELLZUBEHÖR / TABLEROS-CHASIS

Chassis Bracket Steel 107x60x60 e=6
Chassis-Böckchen Stahl 107x60x60 e=6
Fijación Chasis Acero 107x60x60 e=6

NEW

Ref	Kg	Mat	Sup/Finish Acabado	Thickn. Espesor	Lot
2001040	0.58	STEEL		6	10
2001042	0.63	STEEL	Zn	6	10

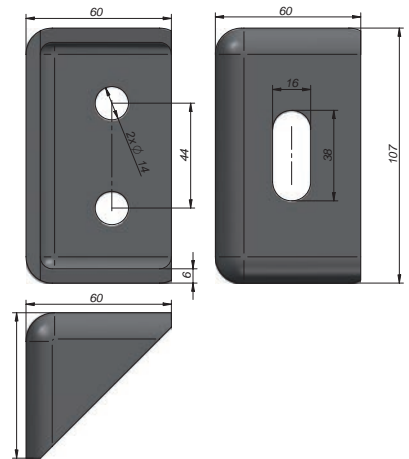

Chassis Bracket Steel 113x157x60 e=6
Chassis-Böckchen Stahl 113x157x60 e=6
Fijación Chasis Acero 113x157x60 e=6

Ref	Kg	Mat	Thickn. Espesor	Lot
2001050	0.96	STEEL	6	10

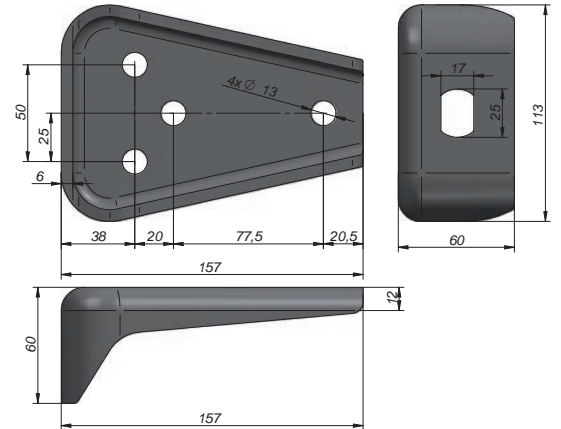

Chassis Bracket Steel 150x60x60 e=4,8
Chassis-Böckchen Stahl 150x60x60 e=4,8
Fijación Chasis Acero 150x60x60 e=4,8

Ref	Kg	Mat	Thickn. Espesor	Lot
2001060	0.81	STEEL	4.85	8

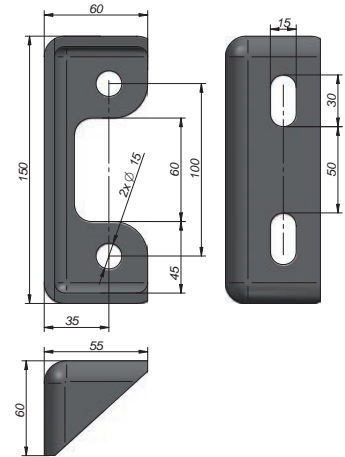

Chassis Silent Block
Fahrgestell-Silentblock
Silenblock Chasis

Ref	Kg	Mat	A	B	C	D	E	Lot
2001080	1.31	STEEL	60	395	310	5	20	4
2001081	1.53	STEEL	60	395	310	5	30	2

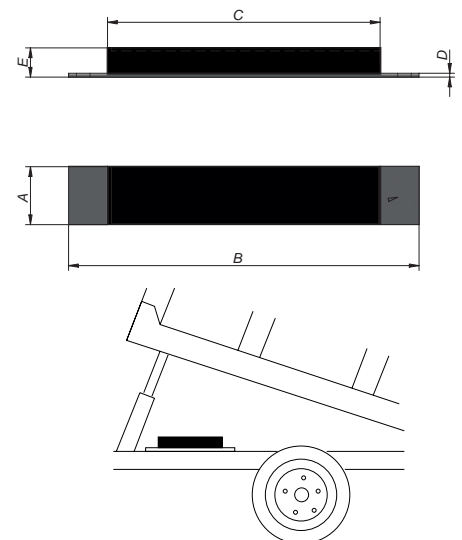
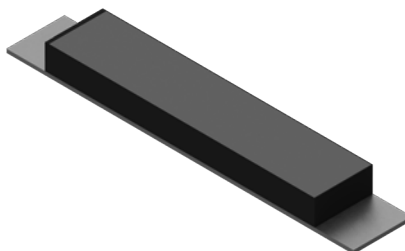



CONTAINER ROLLS

PLYWOOD BOARDS-CHASSIS / BODENPLATTEN-FAHRGESTELLZUBEHÖR / TABLEROS-CHASIS

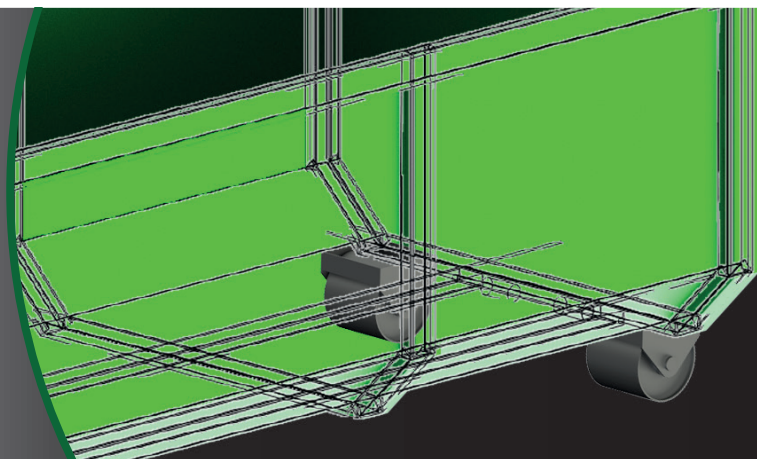
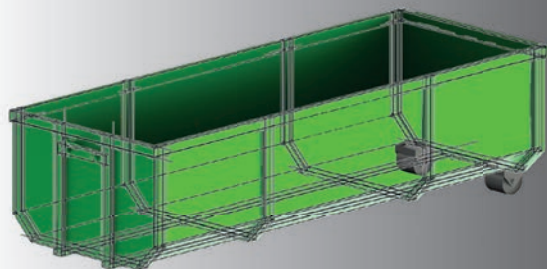

Container Rolls Ø160 with Base
 Container Rollen Ø160 mit Boden
 Rodillo Contenedor Ø160 con Base

Ref	Kg	Mat	Ø	Thickn. Espesor	Lot
2001210	10.8	STEEL	Ø160	6	1

With inner axle bushing
 Con casquillo interior de Nylon

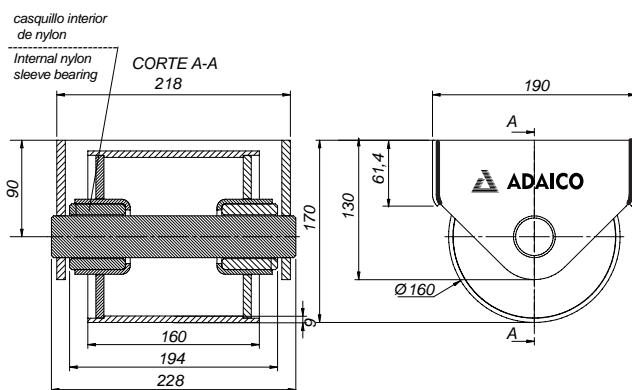

Container Rolls Ø200 with Base
 Container Rollen Ø200 mit Boden
 Rodillo Contenedor Ø200 con Base

Ref	Kg	Mat	Ø	Thickn. Espesor	Lot
2001216	15	STEEL	Ø200	8	1

With inner axle bushing
 Con casquillo interior de Nylon

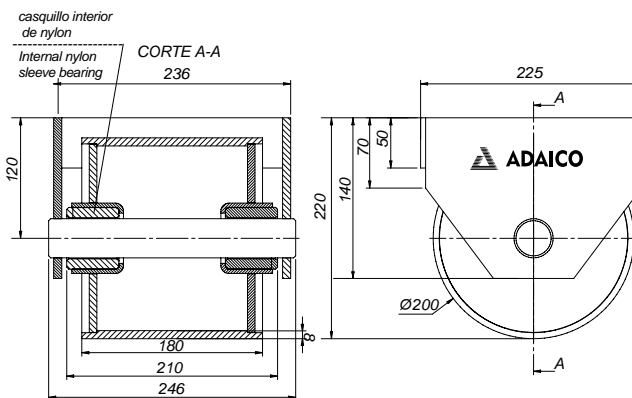

Container Rolls Ø200
 Container Ersatz-Rolle Ø200
 Rodillo Contenedor Ø200

Ref	Kg	Mat	Ø	Thickn. Espesor	Lot
2001224	12.5	STEEL	Ø200	8	1

With inner axle bushing
 Con casquillo interior de Nylon

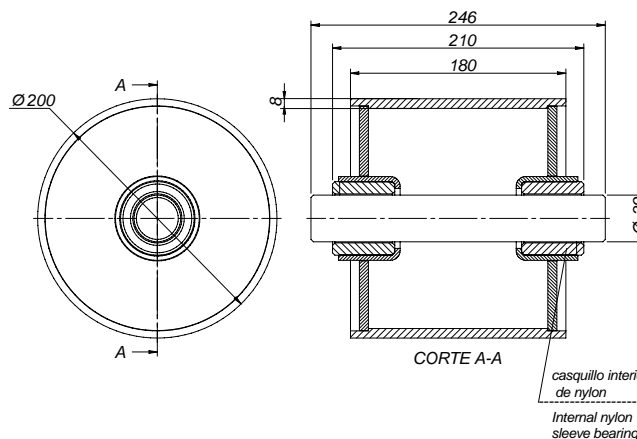
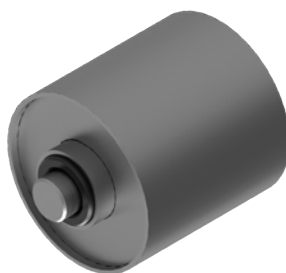

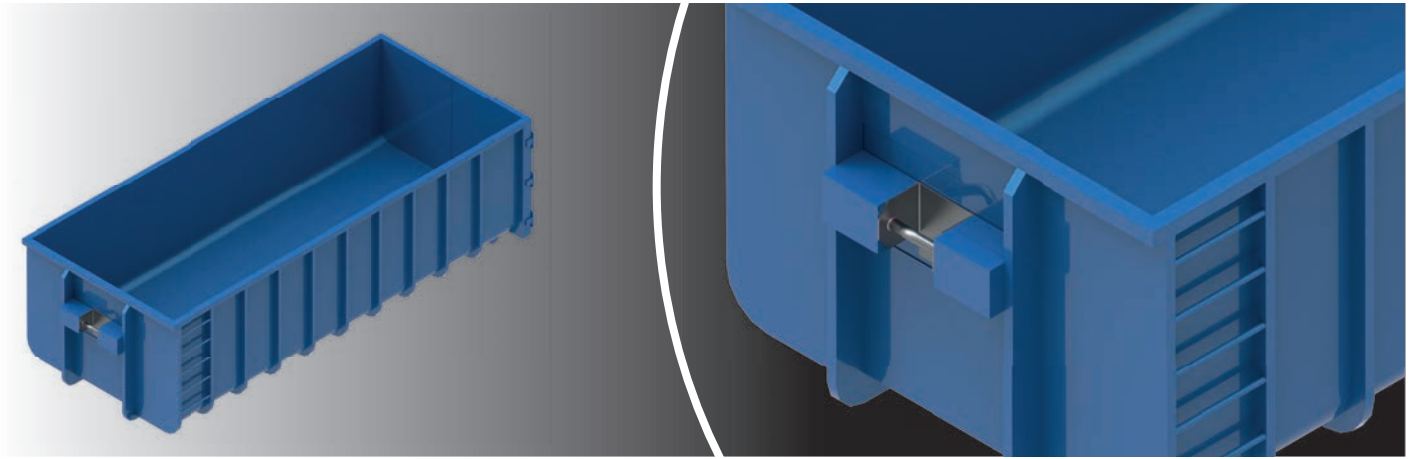

Catch for Tipper Lock
Aufziehbock für Abrollcontainer Stahl schwarz
Anilla de Enganche para Contenedor

Ref	Kg	Mat	Lot
2001246	16	STEEL	1

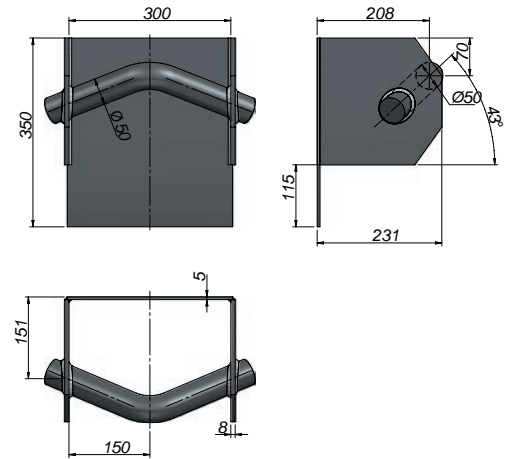

Container Locking Pin 105 mm.
Bolzen Container 105 mm.
Bulón de Contenedor 105 mm.

Ref	Kg	Mat	Lot
2001240	1.72	Forged	1

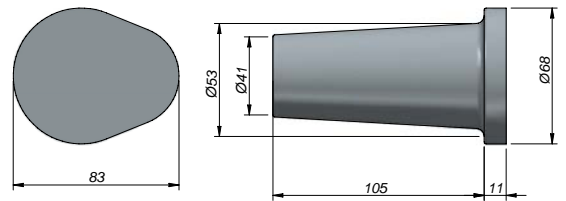

Profile Roll for Container 20m.
Gummidicht-Profil für Container Rolle 20m.
Rollo Perfil Goma 20m. para puerta de Bañera

Ref	Kg	Mat	Col	Lot
1493012	27.5			1

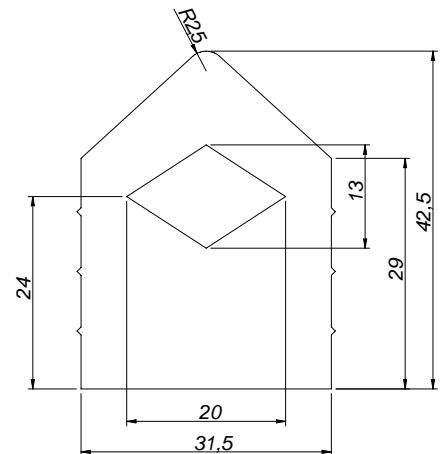

CORNERS CONTAINER

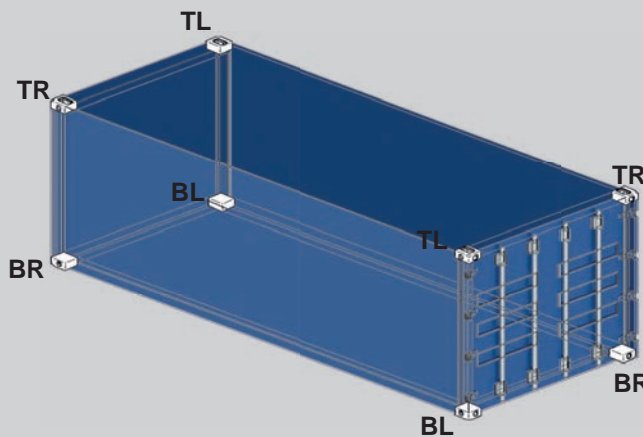

Container Corner ISO 1161
 Containerecken ISO 1161
 Corner Container ISO 1161

Ref	Kg	Mat	Pos	Article	Lot
2001110	11	STEEL	TL	TL	1
2001112	11	STEEL	TR	TR	1
2001114	11	STEEL	BL	BL	1
2001116	11	STEEL	BR	BR	1

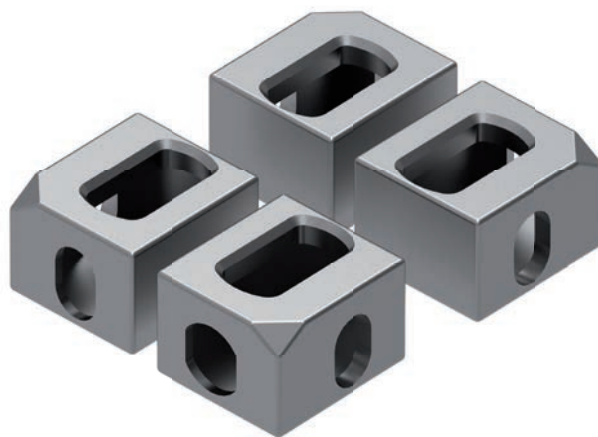

2001110 TL = Sup Izdo / Top Left

2001112 TR = Sup Dcho / Top right

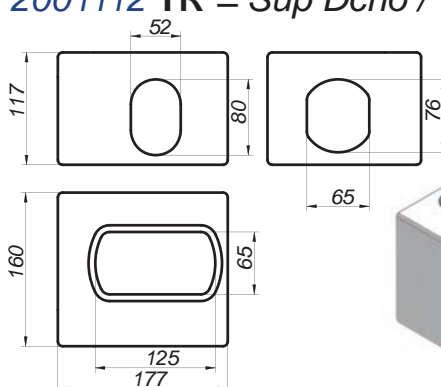
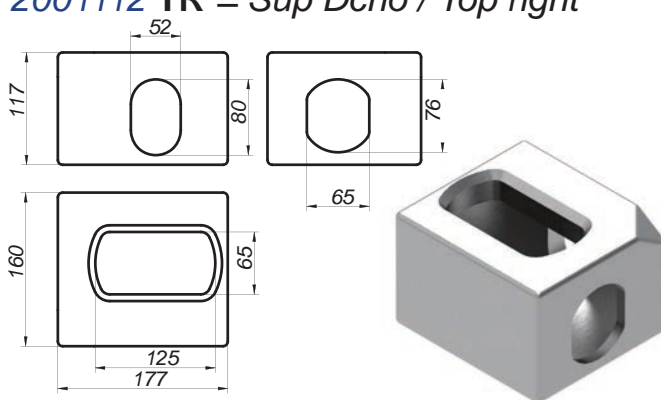
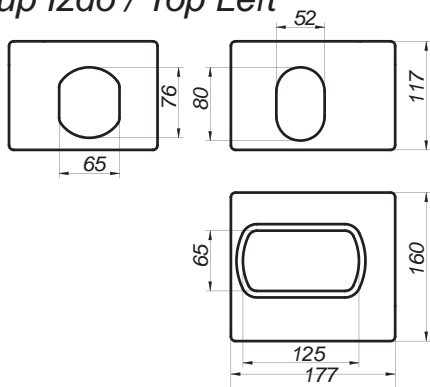

2001114 BL = Inf. Izq. / Bottom Left

2001116 BR = Inf. Dcho. / Bottom right

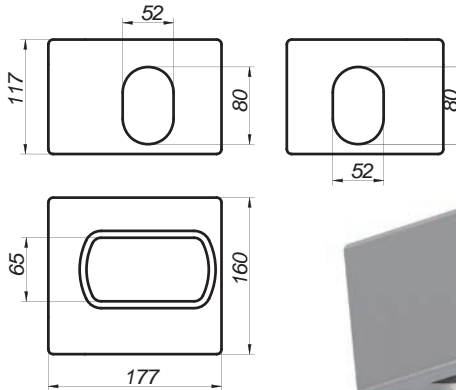
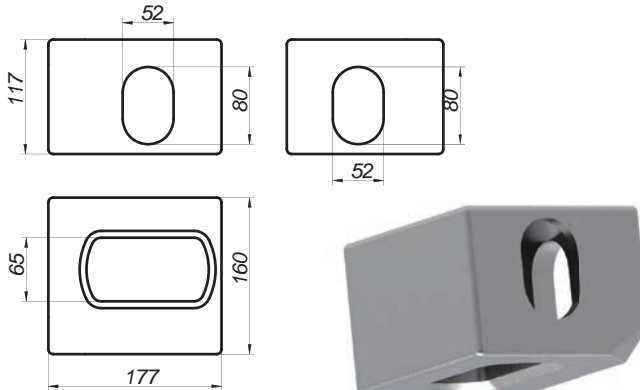
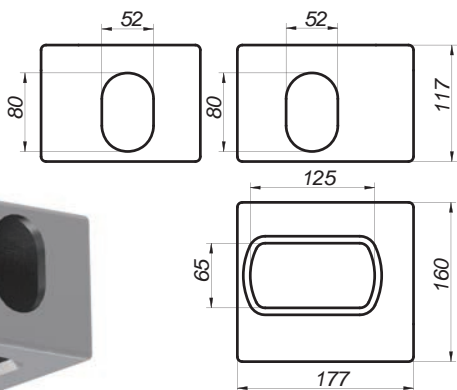



Twist Lock ADAICO (Ø 38 mm.)

Ref	Kg	Mat	Ø	Lot
2001126	10.5	STEEL	Ø38	1

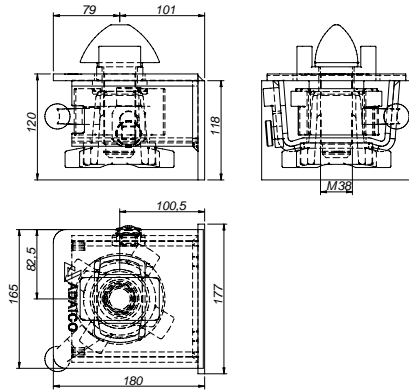

Locking Pin Ø38 f/Twist Lock 2001126
Bolzen Ø38 f/Twist Lock 2001126
Bulón Ø38 para Twist Lock 2001126

Ref	Kg	Mat	Ø	Lot
2001170	2.05	STEEL	Ø38	1



NEW

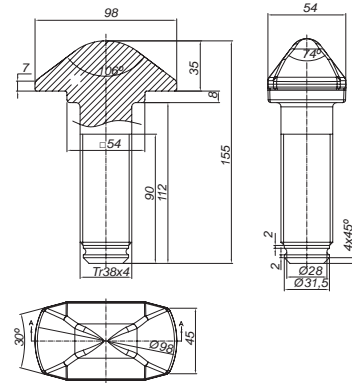

Locking Nut Ø38 f/Twist Lock 2001126
Mutter Ø38 f/Twist Lock 2001126
Tuerca Ø38 para Twist Lock 2001126

Ref	Kg	Mat	Ø	Lot
2001172	2	STEEL	Ø38	1

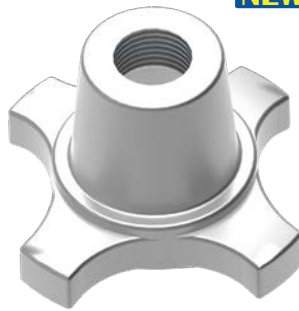

NEW

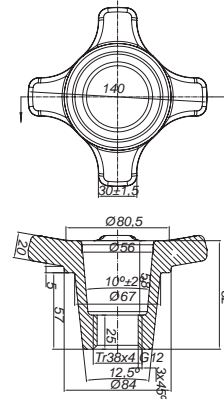

Safety Ring Ø38 f/Twist Lock 2001126
Scheibe Ø38 f/Twist Lock 2001126
Grupilla de Seguridad Ø38 para Twist Lock 2001126

Ref	Kg	Mat	Ø	Lot
2001174	0.01	STEEL	Ø38	10



NEW

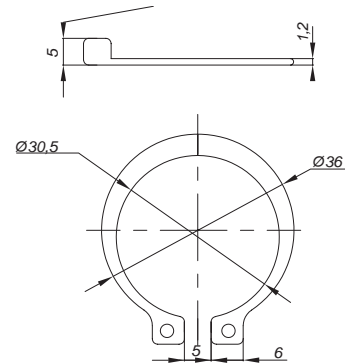

Guide Bush Ø38 f/Twist Lock 2001126
Buchse Ø38 f/Twist Lock 2001126
Casquillo Guía Ø38 para Twist Lock 2001126

Ref	Kg	Mat	Ø	Lot
2001176	0.95	STEEL	Ø38	1



NEW

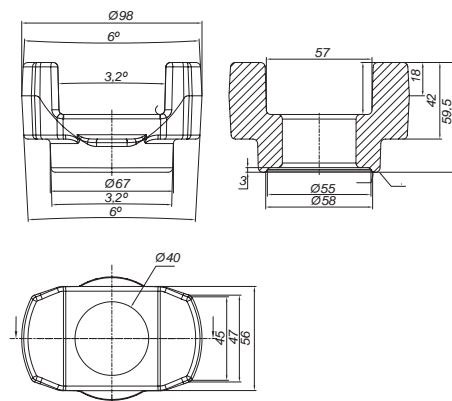



Cross-Bar H100 with 2 Twist-Locks with Roller Holes
 Querstange/2 Twist-Lock H100 mit Löchern für Rollen
 Barra H100 con 2 Twist-Locks c/agujeros Ruletas

NEW

Ref	Kg	Mat
2001180	78	STEEL

Guide rollers not included | Twist lock Ø52 included | For truck trailers chassis following norms DIN 70014 to load containers till 32 Tons
 Ruletas Guía no incluidas | Twist lock Ø52 incluidos | Para chasis de remolques de camión siguiendo normas DIN 70014 para cargar contenedores hasta 32 Tn.

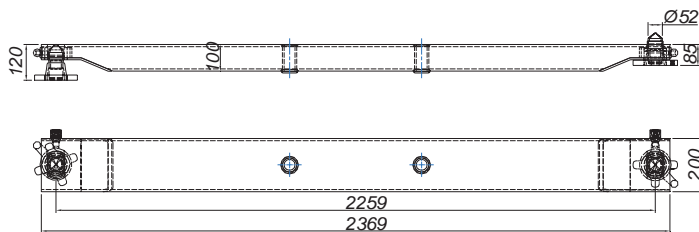

Alignment Guide Rollers Ø100
 Ausrichtrollen Ø100
 Ruletas Guía para Alineamiento Ø100

NEW

Ref	Kg	Mat	Pack
2001182	13.4	STEEL	2

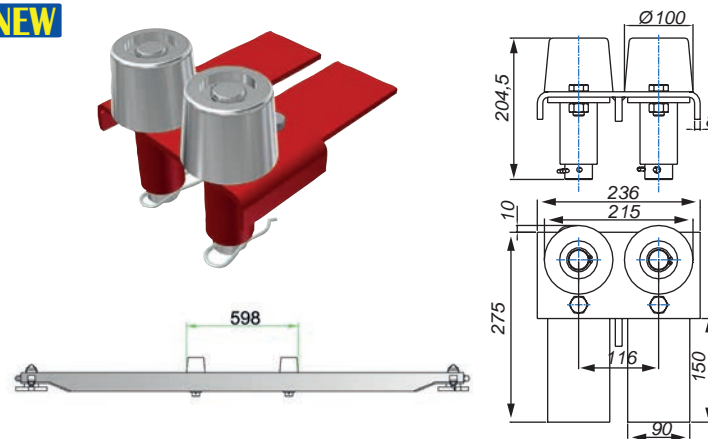

PLYWOOD BOARDS-CHASSIS / BODENPLATTEN-FAHRGESTELLZUBEHÖR / TABLEROS-CHASSIS

Zinc Plated Folding Ladder 1 Step
 Ausziehleiter 1 Stufe, Verzinkt
 Escalera Extraible 1 Peldaño, Cincada

Ref	Kg	Mat	Sup/Finish Acabado	N-Steps Peldaños	Lot
1902036	4.8	STEEL	Zn	1	1

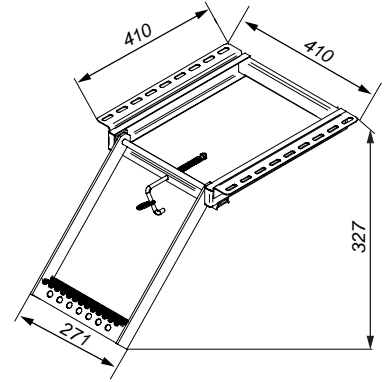

Zinc Plated Folding Ladder 1 Step w/Platform
 Ausziehleiter 1 Stufe mit Plattform, Verzinkt
 Escalera Extraible 1 Peldaño c/Plataforma, Cincada

Ref	Kg	Mat	Sup/Finish Acabado	N-Steps Peldaños	Lot
1902037	8.1	STEEL	Zn	1	1

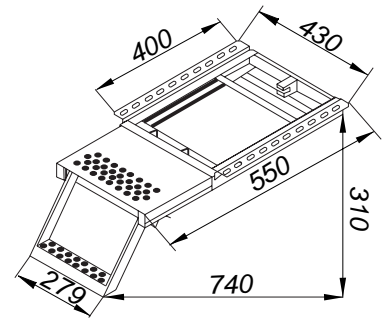

Zinc Plated Folding Ladder 1 Step without plates
 Ausziehleiter 1 Stufe ohne Platte, Verzinkt
 Escalera Extraible 1 Peldaño s/Pletinas, Cincada

Ref	Kg	Mat	Sup/Finish Acabado	N-Steps Peldaños	Lot
1902056	3.75	STEEL	Zn	1	1

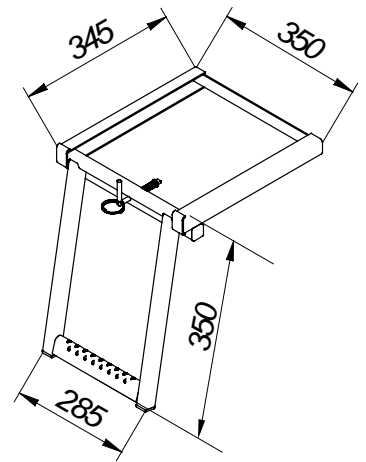

Zinc Plated Folding Ladder 2 Steps 550x407
 Ausziehleiter 2 Stufen 550x407, Verzinkt
 Escalera Extraible 2 Peldaños 550x407, Cincada

Ref	Kg	Mat	Sup/Finish Acabado	N-Steps Peldaños	Lot
1902046	6.4	STEEL	Zn	2	1

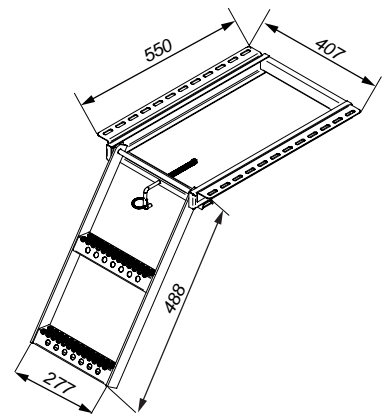



Zinc Plated Folding Ladder 2 Steps 640x410
 Ausziehleiter 2 Stufen 640x410, Verzinkt
 Escalera Extraible 2 Peldaños 640x410, Cincada

Ref	Kg	Mat	Sup/Finish Acabado	N-Steps Peldaños	Lot
1902041	6.9	STEEL	Zn	2	1

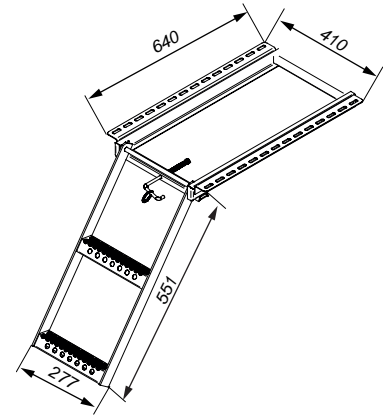
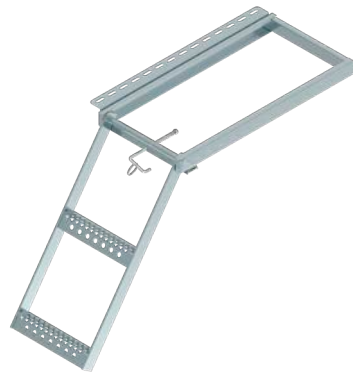

Zinc Plated Folding Ladder 2 Steps w/Platform
 Ausziehleiter 2 Stufen mit Plattform, Verzinkt
 Escalera Extraible 2 Peldaños c/Plataforma, Cincada

Ref	Kg	Mat	Sup/Finish Acabado	N-Steps Peldaños	Lot
1902042	10.6	STEEL	Zn	2	1

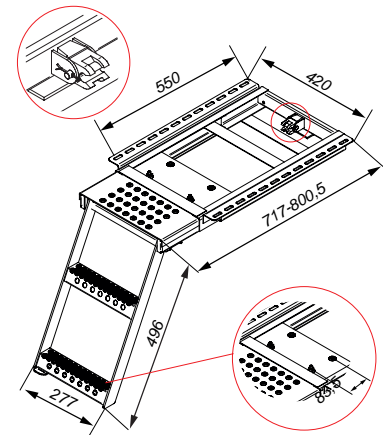

Zinc Plated Folding Ladder 2 Steps with plates
 Ausziehleiter 2 Stufen mit Platte, Verzinkt
 Escalera Extraible 2 Peldaños c/Pletinas, Cincada

Ref	Kg	Mat	Sup/Finish Acabado	N-Steps Peldaños	Lot
1902058	4.74	STEEL	Zn	2	1

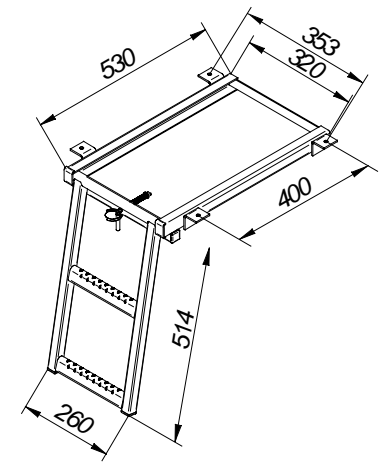

Zinc Plated Folding Ladder 2 Steps w/Platform
 Ausziehleiter 2 Stufen mit Plattform, Verzinkt
 Escalera Extraible 2 Peldaños c/Plataforma, Cincada

Ref	Kg	Mat	Sup/Finish Acabado	N-Steps Peldaños	Lot
2519013	11.5	STEEL	Zn	2	1

With opening and closing handle
 Con manilla de apertura y cierre

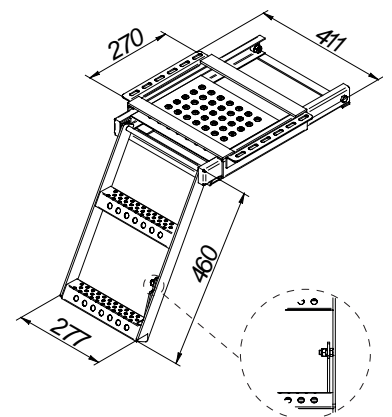

PLYWOOD BOARDS-CHASSIS / BODENPLATTEN-FAHRGESTELLZUBEHÖR / TABLEROS-CHASIS



LADDERS / LEITERN / ESCALERAS

PLYWOOD BOARDS-CHASSIS / BODENPLATTEN-FAHRGESTELLZUBEHÖR / TABLEROS-CHASIS

Zinc Plated Folding Ladder 2 Steps without plates
Ausziehleiter 2 Stufen ohne Platte, Verzinkt
Escalera Extraible 2 Peldaños s/Pletinas, Cincada

Ref	Kg	Mat	Sup/Finish Acabado	N-Steps Peldaños	Lot
2519011	4.74	STEEL	Zn	2	1

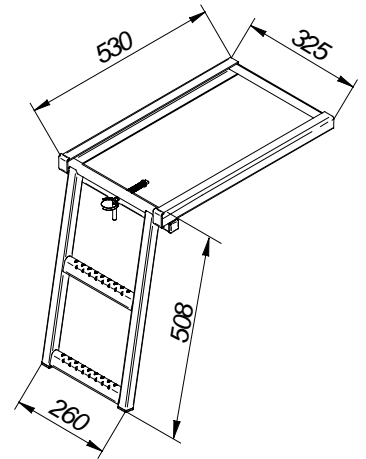

Zinc Plated Folding Ladder 3 Steps
Ausziehleiter 3 Stufen, Verzinkt
Escalera Extraible 3 Peldaños, Cincada

Ref	Kg	Mat	Sup/Finish Acabado	N-Steps Peldaños	Lot
1902050	7.82	STEEL	Zn	3	1

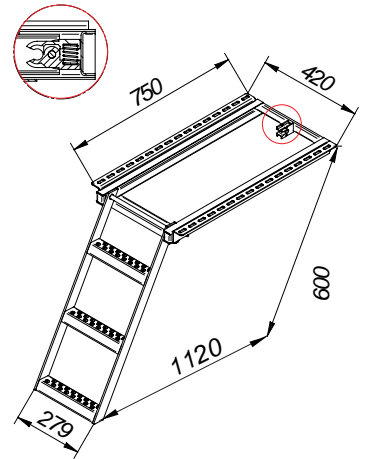

Zinc Plated Folding Ladder 3 Steps
Ausziehleiter 3 Stufen, Verzinkt
Escalera Extraible 3 Peldaños, Cincada

Ref	Kg	Mat	Sup/Finish Acabado	N-Steps Peldaños	Lot
1902049	8	STEEL	Zn	3	1

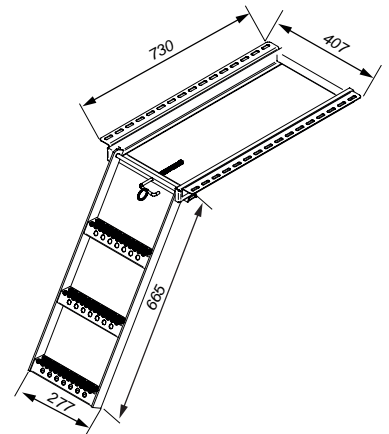

Zinc Plated Folding Ladder 3 Steps w/Platform
Ausziehleiter 3 Stufen mit Plattform, Verzinkt
Escalera Extraible 3 Peldaños c/Plataforma, Cincada

Ref	Kg	Mat	Sup/Finish Acabado	N-Steps Peldaños	Lot
1902051	12	STEEL	Zn	3	1

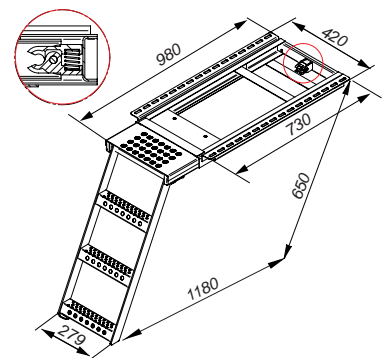



Zinc Plated Folding Ladder 3 Steps w/Platform w/Handle
 Ausziehleiter 3 Stufen mit Plattform mit Griff, Verzinkt
 Escalera Extraible 3P c/Plataforma c/Manilla, Cincada

Ref	Kg	Mat	Sup/Finish Acabado	N-Steps Peldaños	Lot
1902052	12.1	STEEL	Zn	3	1

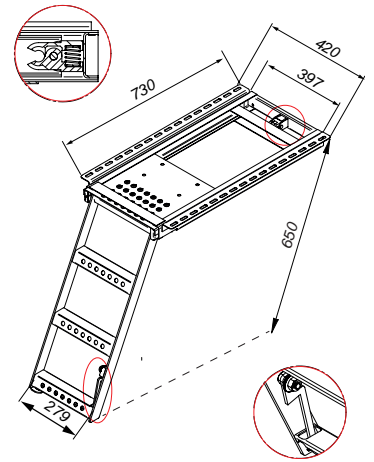

Zinc Plated Folding Ladder 3 Steps with plates
 Ausziehleiter 3 Stufen mit Platte, Verzinkt
 Escalera Extraible 3 Peldaños c/Pletinas, Cincada

Ref	Kg	Mat	Sup/Finish Acabado	N-Steps Peldaños	Lot
1902060	5.92	STEEL	Zn	3	1

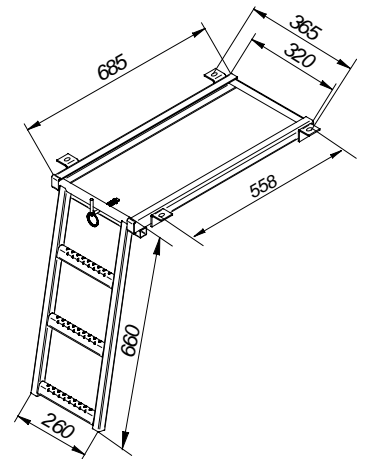

Black KTL Folding Ladder 3 Steps
 Ausziehleiter 3 Stufen, Schwarz KTL 3 Marches, Noir (KTL)
 Escalera Extraible 3 Peldaños, Negra (KTL)

Ref	Kg	Sup/Finish Acabado	Col	Article	Lot
2519017	6.7	KTL	●		1

Retractable third step
 Tercer peldaño escamoteable

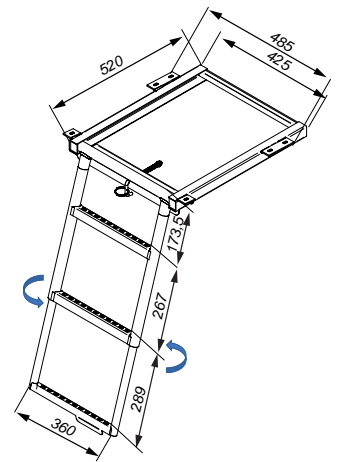

Galvanized Retractable Ladder 2 Steps
 Ausklappbare Treppe 2 Stufen, Feuerverzinkt
 Escalera Escamoteable 2 Peldaños, Galvanizada

Ref	Kg	Mat	Sup/Finish Acabado	N-Steps Peldaños	Lot
1902070	22.5	STEEL	Galv	2	1

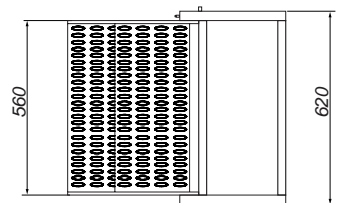
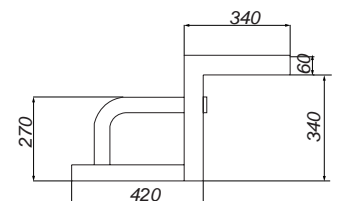

PLYWOOD BOARDS-CHASSIS / BODENPLATTEN-FAHRGESTELLZUBEHÖR / TABLEROS-CHASIS



LADDERS / LEITERN / ESCALERAS

PLYWOOD BOARDS-CHASSIS / BODENPLATTEN-FAHRGESTELLZUBEHÖR / TABLEROS-CHASIS

Galvanized Suspended Folding Ladder 2 Steps with Handles
Trittleiter Ausziehbar Freistehend 2 Stufen mit Griff, Feuerverzinkt
Escalera Suspendida 2 Peldaños c/Asa, Galvanizada

Ref	Kg	Mat	Sup/Finish Acabado	N-Steps Peldaños	Lot
2519003	22	STEEL	Galv	2	1

Antislip GRAEPEL Step
Peldaño GRAEPEL con superficie antideslizante

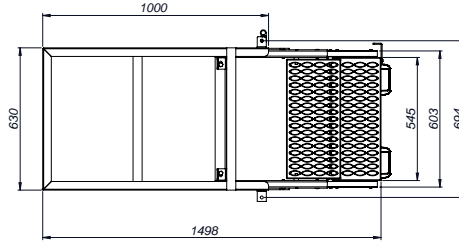
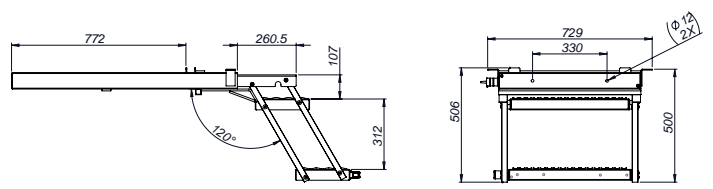

Galv. Suspended Folding Ladder 3 Steps w/Handles w/Handrail
Trittleiter Ausziehbar Freistehend 3 Stufen m/Handgriff m/Handlauf, Verzinkt
Escalera Suspendida 3 Peldaños c/Asa c/Pasamanos, Galv.

NEW

Ref	Kg	Mat	Sup/Finish Acabado	N-Steps Peldaños	Lot
2519005	35.62	STEEL	Galv	3	1

Antislip GRAEPEL Step
Peldaño GRAEPEL con superficie antideslizante

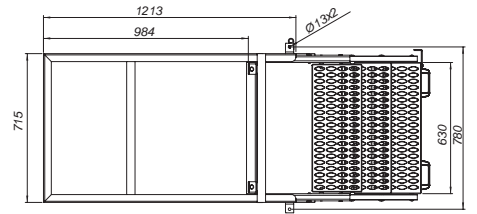
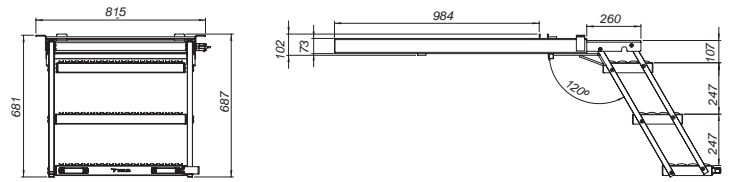

Zinc Plated Folding Ladder with Frameladder
Ausziehtreppe mit Anbaurahmen, Verzinkt, Zingué
Escalera Extraíble + Guía, Cincada

Ref	Kg	Mat	Sup/Finish Acabado	A	B	C	D	N-Steps Peldaños	Lot
1902082	32	STEEL	Zn	1269	841	1592	1210	4	1
1902086	39	STEEL	Zn	1471	1042	1877	1210	5	1
1902092	44	STEEL	Zn	1672	1244	2162	2065	6	1

Antislip Graepel Step | Frameladder including | M8x20 - DIN933 - 8.8
Peldaño Graepel con superficie antideslizante | Incluye guía extraíble | M8x20 - DIN933 - 8.8

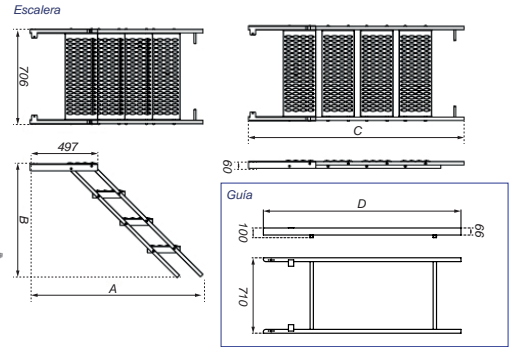

Galvanized Folding Ladder
Ausziehtreppe, Feuerverzinkt
Escalera Extraíble + Guía, Galvanizada

Ref	Kg	Mat	Sup/Finish Acabado	A	B	N-Steps Peldaños	Lot
2519004	25	STEEL	Zn	1501	565	3	1
2519006	36	STEEL	Zn	1786	810	4	1
2519008	45	STEEL	Zn	2071	1005	5	1

Non-slip step.
Peldaño antideslizante.

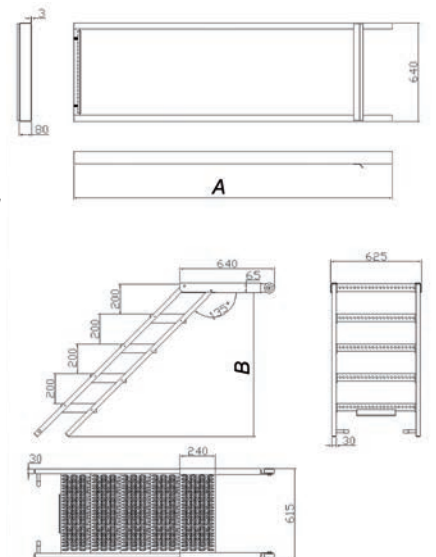

Zinc Plated Step Folding
Klapptritt, Verzinkt
Peldaño Abatible Cincado

Ref	Kg	Mat	Sup/Finish Acabado	Lot
1902300	1.42	STEEL	Zn	1

Antislip Surface
Superficie antideslizante

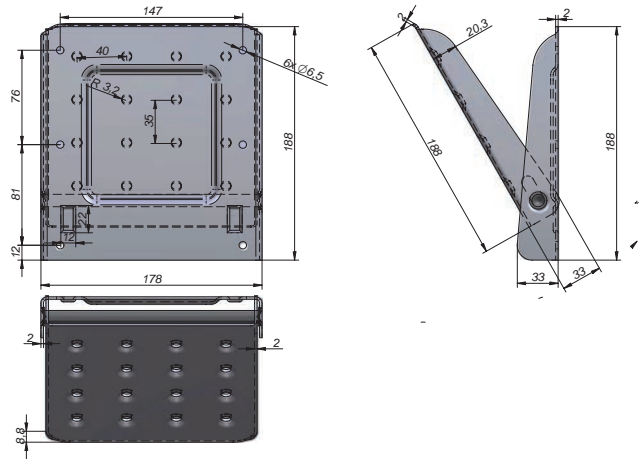

Step Folding
Klappstufe, Verzinkt
Peldaño Abatible

Ref	Kg	Mat	Sup/Finish Acabado	Lot
1902304	0.56	STEEL	Zn	2

Antislip Surface
Superficie antideslizante

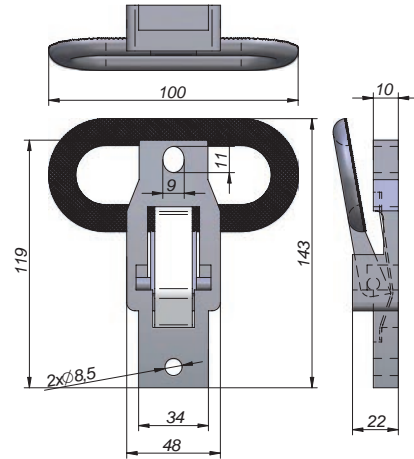

Zinc Plated Step Fix
Auftritt Feststehend, Verzinkt
Peldaño Fijo Cincado

Ref	Kg	Mat	Sup/Finish Acabado	A	B	Lot
1902320	1.2	STEEL	Zn	250	405	1
1902322	1.54	STEEL	Zn	360	420	2

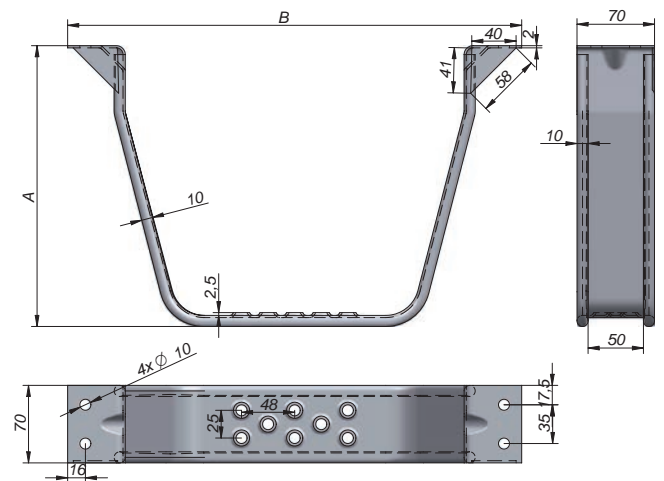

PLYWOOD BOARDS-CHASSIS / BODENPLATTEN-FAHRGESTELLZUBEHÖR / TABLEROS-CHASIS

REAR BUMPER

HOMOLOGATED REAR BUMPERS R58/03 PARAGOLPES TRASEROS HOMOLOGADOS R58/03



BODY TYPE TIPO CARROCERIA	MODELO / MODÈLE			
	GMF	GMH	GME	GMR
TIPPER TRUCK VOLQUETES			★ ★ ★	★ ☆ ☆
CRANE TRUCK CAMIÓN GRUA	★ ☆ ☆	★ ★ ★	★ ★ ☆	★ ★ ☆
CONTAINER CHAIN CARRIER TRUCK PORTACONTENEDORES CADENA	★ ★ ★		★ ☆ ☆	★ ★ ☆
PLATFORM TRUCK PLATAFORMA	★ ★ ★		★ ☆ ☆	★ ☆ ☆

4 MODELS AVAILABLE IN REGULATION R58/03:

- GMF: FIXED
 - 2 lengths available: Arm 230/330 mm.
 - 2 possible inclinations
- GMH: EXTENSIBLE HORIZONTAL
 - 4 length available: Opening 400/600/750/900 mm.
 - Hydraulic or Manual System
 - Tube diameter: Ø120 mm
- GME: RETRACTABLE
 - 2 Tube diameter: Ø100 y Ø120 mm.
 - Hydraulic System
- GMR: LIFTABLE
 - 4 lengths available
 - 2 Tube diameter: : Ø100 y Ø120 mm.
 - Hydraulic or Manual System

4 MODELOS DISPONIBLES EN NORMATIVA R58/03:

- GMF: FIJO
 - 2 longitudes disponibles: Brazo 230/330 mm.
 - 2 posibles inclinaciones
- GMH: EXTENSIBLE HORIZONTAL
 - 4 longitudes disponibles: Apertura 400/600/750/900 mm.
 - Sistema Hidráulico o Manual
 - Diámetro de tubo: Ø120 mm
- GME: ESCAMOTEABLE
 - 2 diámetros de tubo: Ø100 y Ø120 mm.
 - Sistema Hidráulico
- GMR: ELEVABLE
 - 4 longitudes disponibles
 - 2 diámetros de tubo: Ø100 y Ø120 mm.
 - Sistema Hidráulico



GMF
Fixed
Fijo



GMH
Extensible Horizontal
Extensible Horizontal



GME
Retractable
Escamoteable



GMR
Liftable
Elevable

¿WHY 2 TUBE DIAMETERS 100 OR 120 MM?

Our Bumpers are approved for N2 (G) and N3 (G) vehicles.
-N2 (G) corresponds to heavy vehicles up to 12T.
-N3 (G) corresponds to heavy vehicles over 12T.
-The letter G includes vehicles classified as "all-terrain", that is, heavy vehicles that can travel on roads and in quarries.

N2 (G) heavy vehicles up to 12T:

- N2 < 8T: 100 mm tube (not N2 (G) in < 8T)
- N2 > 8T: 120 mm tube.
- N2 (G) > 8T: 100 mm tube.

N3 (G) from 12T:

- N3: 120 mm tube
- N3 (G): 100 mm tube

¿POR QUÉ 2 DIÁMETROS DE TUBO 100 O 120 MM?

Nuestros Paragolpes están homologados para vehículos N2 (G) y N3 (G).
-N2 (G) corresponde a vehículos pesados de hasta 12T.
-N3 (G) corresponde a vehículos pesados de más de 12T.
-La letra G incluye vehículos clasificados como "todoterreno", es decir, vehículos pesados que pueden circular por carretera y en canteras.

N2 (G) vehículos pesados de hasta 12T:

- N2 < 8T: tubo de 100 mm (no de N2 (G) en < 8T)
- N2 > 8T: tubo de 120 mm.
- N2 (G) > 8T: tubo de 100 mm.

N3 (G) a partir de 12T:

- N3: tubo de 120 mm
- N3 (G): tubo de 100 mm

Fixed Rear Bumper ECE R58.03
Heck-Stoßfänger, Fix, ECE R58.03
Paragolpes Trasero Fijo ECE R58.03

Ref	Kg	Pos	Ø	Emark	Arm / Brazo	Lot
1701101	100		Ø120	E ₂	Long (330 mm.) Largo (330 mm.)	1
1701102	100		Ø120	E ₂	Short (230 mm.) Corto (230 mm.)	1

ECE R58.03

NEW

GMF



Extensible Rear Bumper ECE R58.03
Heck-Stoßfänger, versenkbar, ECE R58.03
Paragolpes Trasero Extensible ECE R58.03

Ref	Kg	Pos	Emark	Opening / Apertura	Lot
1701121	178		E ₂	Hydraulic 400 mm. Hidráulico 400 mm.	1
1701141	178		E ₂	Manual 400 mm.	1
1701122	184		E ₂	Hydraulic 600 mm. Hidráulico 600 mm.	1
1701142	184		E ₂	Manual 600 mm.	1
1701123	188		E ₂	Hydraulic 750 mm. Hidráulico 750 mm.	1
1701143	188		E ₂	Manual 750 mm.	1
1701124	180		E ₂	Hydraulic 900 mm. Hidráulico 900 mm.	1
1701144	192		E ₂	Manual 900 mm.	1

ECE R58.03

NEW

GMH Manual / Manual
Hidráulico / Hydraulic

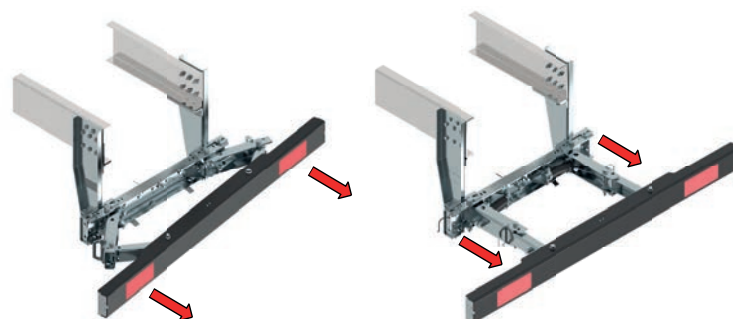

Hydraulic Retractable Rear Bumper ECE R58.03
Hydraulisch Heck-Stoßfänger, Einziehbar ECE R58.03
Paragolpes Trasero Escamoteable Hidráulico ECE R58.03

Ref	Kg	Pos	Ø	Emark	Lot
1701161	130		Ø100	E ₂	1
1701162	140		Ø120	E ₂	1

ECE R58.03

NEW

GME Hidráulico
Hydraulic

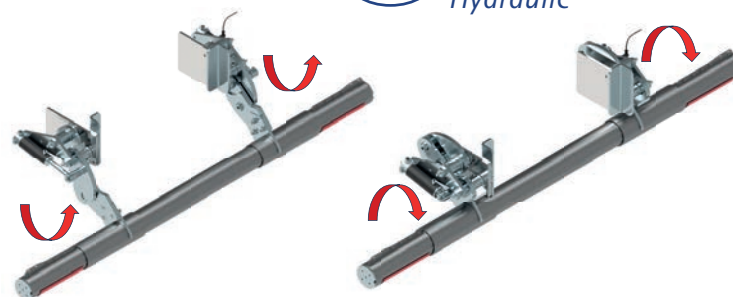

Hydraulic Rear Bumper with Elevation ECE R58.03
Hydraulisch Heck-Stoßfänger, Hebender ECE R58.03
Paragolpes Trasero Elevable Hidráulico ECE R58.03

Ref	Kg	Pos	A	Ø	Emark	Arm / Brazo	Lot
1701181	130		396	Ø100	E ₂	Short Corto	1
1701182	140		396	Ø120	E ₂	Short Corto	1
1701183	130		426	Ø100	E ₂	Medium Medio	1
1701184	140		426	Ø120	E ₂	Medium Medio	1
1701185	130		455	Ø100	E ₂	Large Largo	1
1701186	140		455	Ø120	E ₂	Large largo	1
1701187	130		489	Ø100	E ₂	Extra-large Extralargo	1
1701188	140		489	Ø120	E ₂	Extra-large Extralargo	1

ECE R58.03

NEW

GMR Hidráulico
Hydraulic

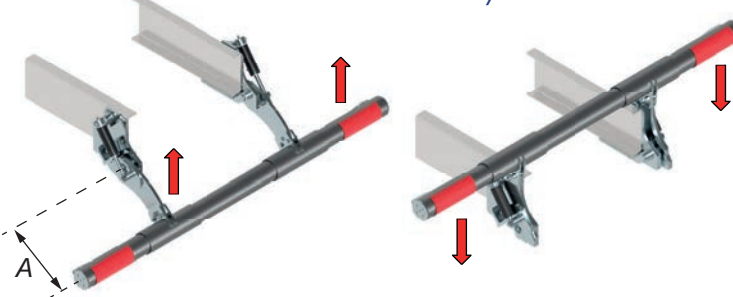

PLYWOOD BOARDS-CHASSIS / BODENPLATTEN-FAHRGESTELLZUBEHÖR / TABLEROS-CHASIS



PARAGOLPES TRASERO EN ALUMINIO ALUMINIUM REAR BUMPER

SOPORTES Y REFUERZOS
SUPPORT & REINFORCEMENTS

R58/03

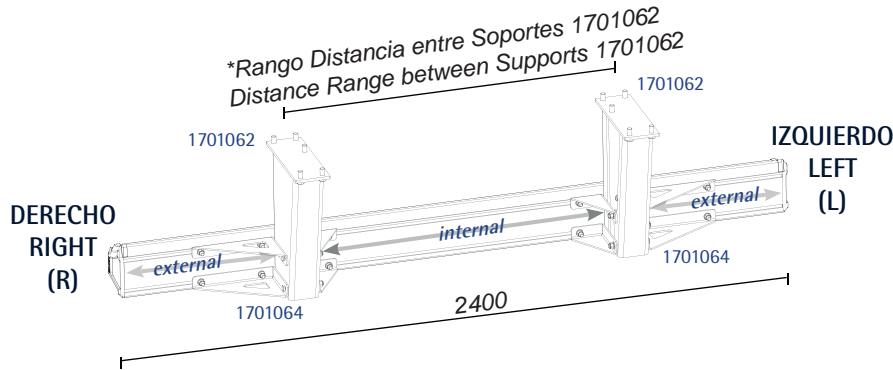
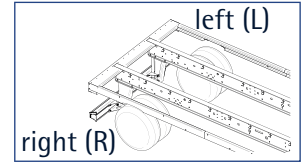
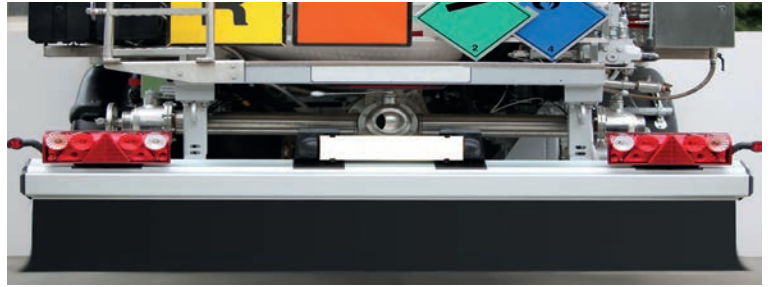

*Configuración colocación Refuerzos 1701064
(Configuration placement Brackets 1701064)

650-1199	1200-1350	1351-1450
A	A	B

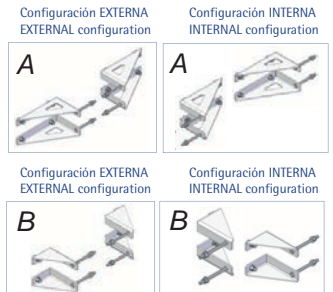

Anodized Aluminium Rear Bumper ECE R58.03
Heck-Stoßfänger, Alu Eloxiert, ECE R58.03
Paragolpes Trasero Anodizado ECE R58.03

NEW

Ref	Kg	Mat	Sup/Finish Acabado	E-mark	Lot
1701060	21.4		Anod		1

Material: Aluminium 6082 T6
Material: Aluminio 6082 T6
ECE R58.03

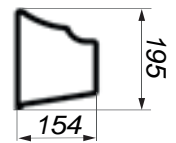

Weldable 2-Kit Supports for Alu Bumper 1701060
Stahl-Halter Schweißbar für Heck-Stoßfänger 1701060
Kit 2 Soportes Soldables p/Paragolpes Alu 1701060

NEW

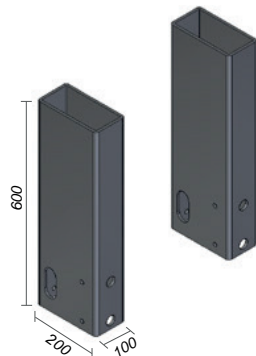

Ref	Kg	Mat	Lot
1701062	41	STEEL	1

Universal Brackets for Alu Bumper 1701060
Stahl-Halter Universal für Heck-Stoßfänger 1701060
Kit Fijaciones p/Paragolpes Aluminio 1701060

NEW

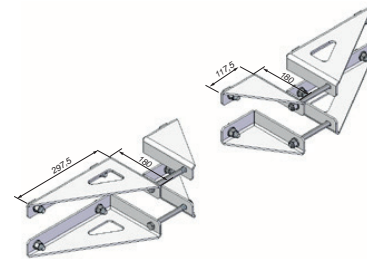

Ref	Kg	Mat	Sup/Finish Acabado	Col	Lot
1701064	12	STEEL	KTL		1

Anodized Aluminium Rear Bumper ECE R58.03
 Heck-Stoßfänger, Aluminium eloxiert, ECE R58.03
 Paragolpes Trasero Aluminio Anodizado ECE R58.03

Ref	Kg	Mat	Sup/Finish Acabado	Emark	Lot
1701038	23.95		Anod		1

Plastic caps included
 Incluye tapas de plástico
 ECE R58.03

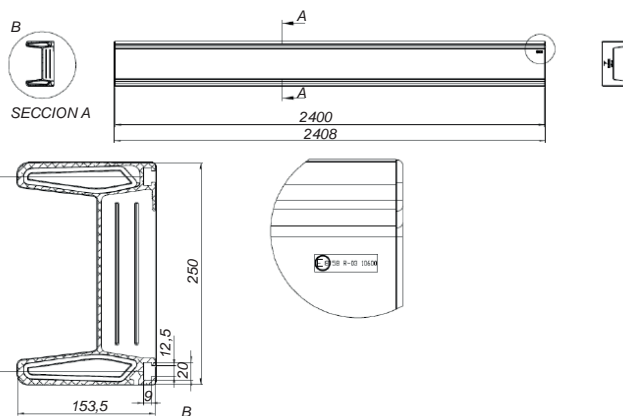

2 Brackets Set In Rough for Alu Bumper 1701038
 2 Set Stahl-Halter für Heck-Stoßfänger 1701038
 Kit 2 Soportes Hierro para Paragolpes Aluminio 1701038

Ref	Kg	Mat	Lot
1701036	38	STEEL	1

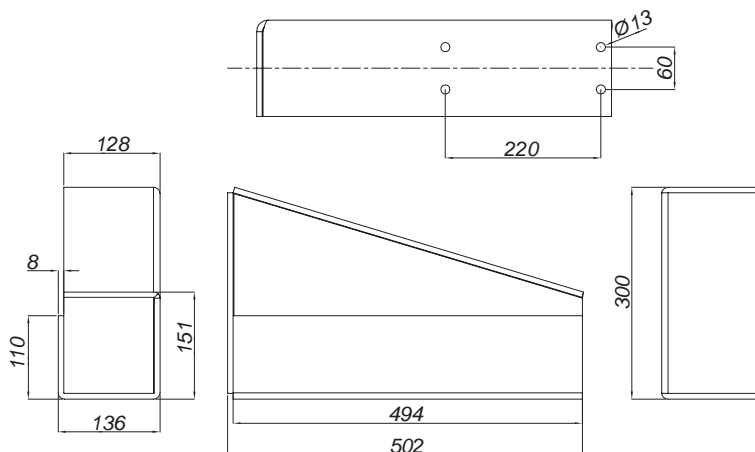

Fixing Insert for Aluminium Bumper 1701038
 Befestigungssatz für Heckstoßfänger 1701038 Aus Aluminium
 Fijacion para Paragolpes Aluminio 1701038

Ref	Kg	Mat	Metric	Lot
1701046	1.35	STEEL	M12	1

Comprend: 1 plaque, 3 vis, 3 écrous et 3 rondelles
 Incluye: 1placa, 3 tornillos, 3 tuercas y 3 arandelas

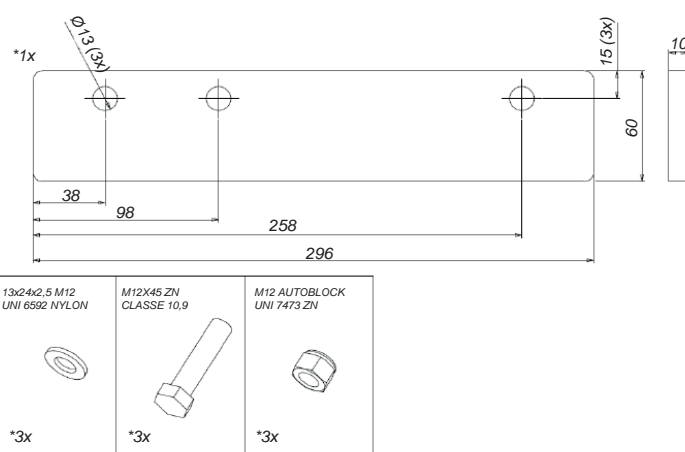

Plastic Cap for Rear Bumper 1701038
 Kunststoff-Endkappe für Heck-Stoßfänger 1701038
 Tapa plástico para Paragolpes 1701038

Ref	Kg	Mat	Lot
1701045	0.18		2

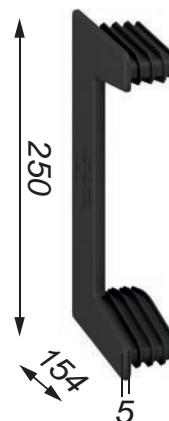



BUMPERS / HECKSTOSSFÄNGER / PARAGOLPES TRASERO

PLYWOOD BOARDS-CHASSIS / BODENPLATTEN-FAHRGESTELLZUBEHÖR / TABLEROS-CHASIS

Anodized Aluminium Rear Bumper ECE R58.02
Heck-Stoßfänger, Aluminium eloxiert, ECE R58.02
Paragolpes Trasero Aluminio Anodizado ECE R58.02

Ref	Kg	Mat	Sup/Finish Acabado	Emark	Lot
1701040	16.9		Anod		1

ECE R58.02

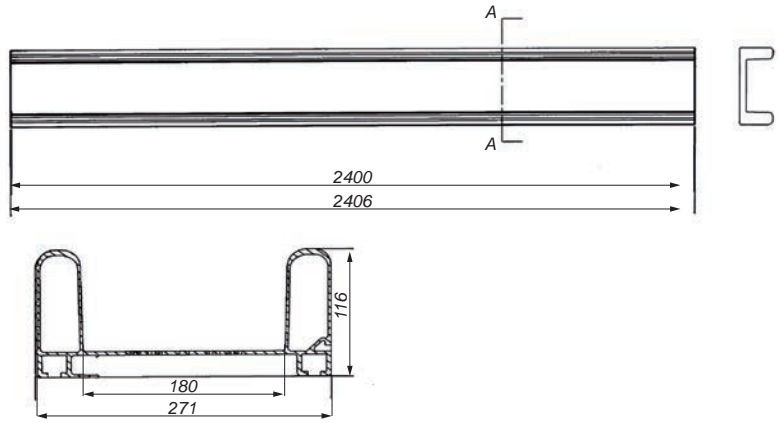

2 Brackets Set In Rough for Alu Bumper 1701040
2 Set Stahl-Halter für Heck-Stoßfänger 1701040
Kit 2 Soportes Hierro para Paragolpes Aluminio 1701040

Ref	Kg	Mat	Lot
1701042	38	STEEL	1

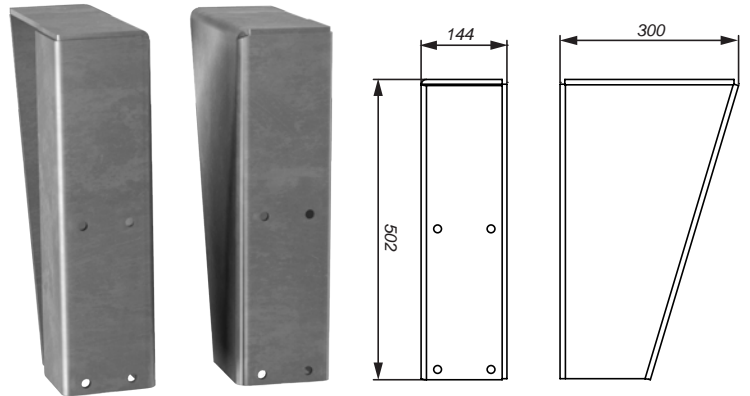

Pack 4 Set Fixing Insert for Aluminium Bumper 1701040
Pack 4 Set Befestigungssatz für Heckstoßfänger 1701040 Alu
Pack 4 Kits Fijacion p/Paragolpes Aluminio 1701040

Ref	Kg	Mat	Metric	Lot	Pack
1701047	0.48	STEEL	M12	1	4

Complete pack for a support |
Contains 4 Kits: 4 Screws, 4 Washers, 4 Nuts and 8 plates (2 different types)
Pack completo para un soporte |
Contiene 4 Kits: 4 Tornillos, 4 Arandelas, 4 Tuercas y 8 pletinas (2 tipos diferentes)

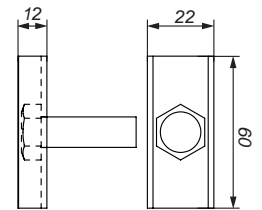

Plastic Cap for Rear Bumper 1701040
Kunststoff-Endkappe für Heck-Stoßfänger 1701040
Tapa plástico para Paragolpes 1701040

Ref	Kg	Mat	Lot
1701044	0.18		1

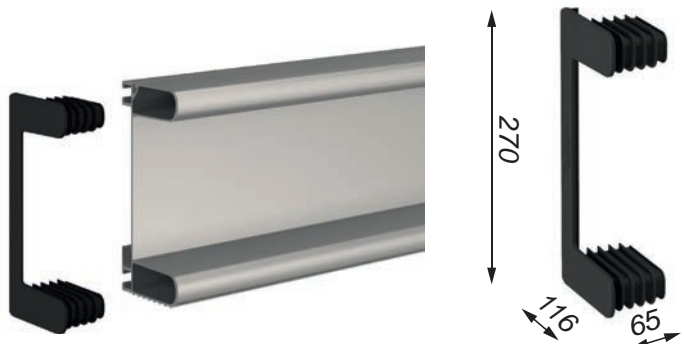

Rear Bumper
Heck-Stoßfänger
Paragolpes Trasero

Ref	Kg	Mat	A	B	Thickn. Espesor	Lot
1701004	13.6		2400	34	5	1

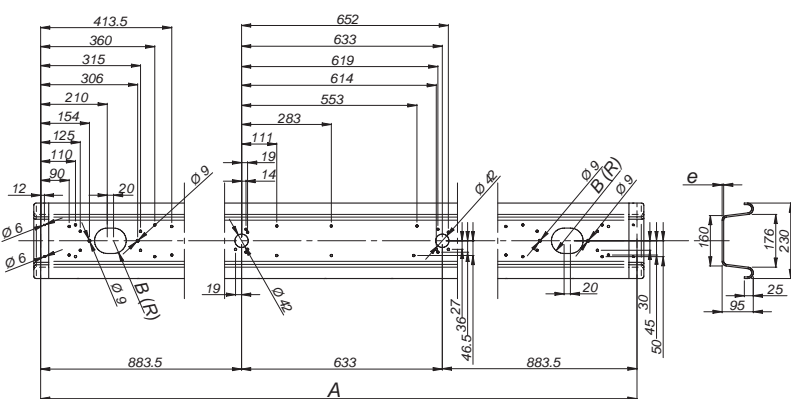

Plastic Cap for Rear Bumper 1701004/06
Kunststoff-Endkappe für Heck-Stoßfänger 1701004/06
Terminal Plástico para Paragolpes Trasero 1701004/06

Ref	Kg	Mat	Lot
1701009	0.13		2

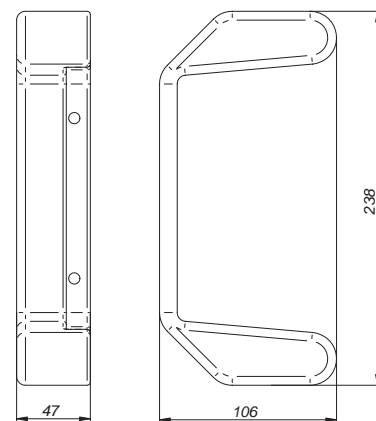

Rear Bumper
Heck-Stoßfänger, Stahl, grau
Paragolpes Trasero

Ref	Kg	Mat	Col	A	Thickn. Espesor	Lot
1701005	13.5			2300	2	1
1701007	14.1			2400	2	1

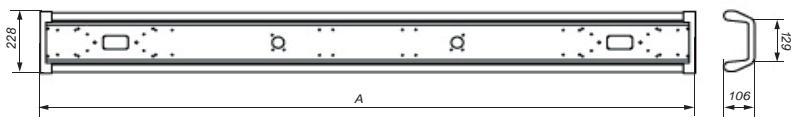

Plastic Cap for Rear Bumper 1701005/07
Kunststoff-Endkappe für Heck-Stoßfänger 1701005/07
Terminal Plástico para Paragolpes Trasero 1701005/07

Ref	Kg	Mat	Lot
1701012	0.13		1

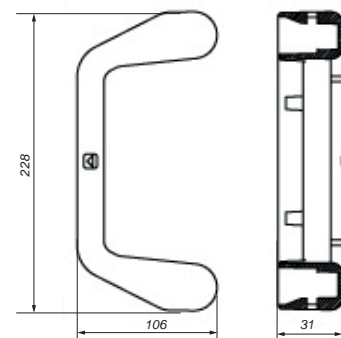



BUMPERS / HECKSTOSSFÄNGER / PARAGOLPES TRASERO

PLYWOOD BOARDS-CHASSIS / BODENPLATTEN-FAHRGESTELLZUBEHÖR / TABLEROS-CHASSIS

Rear Bumper 2400x230 e=2
Heck-Stoßfänger 2400x230 e=2
Paragolpes Trasero 2400x230 e=2

NEW

Ref	Kg	Mat	Sup/Finish Acabado	Col	A	Thickn. Espesor	Lot
1701008	15	STEEL	Zn		2400	2	1

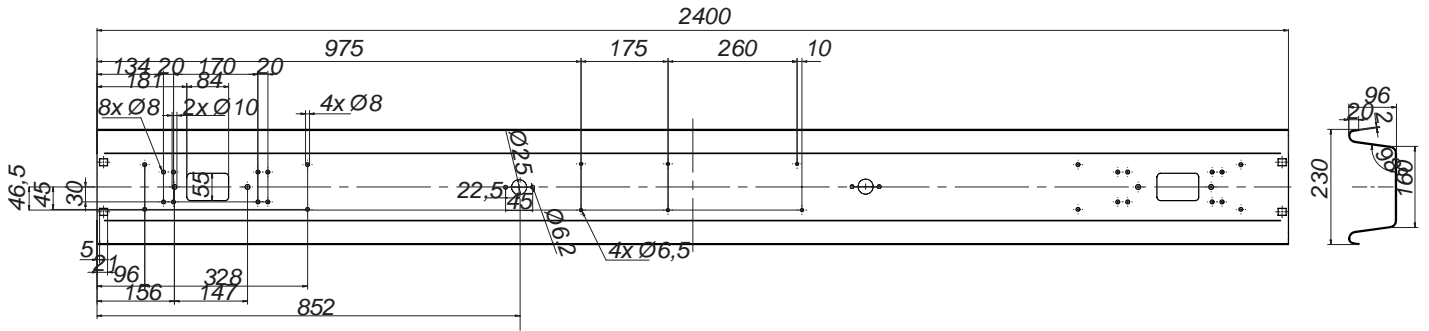

Plastic Cap for Rear Bumper 1701008
Kunststoff-Endkappe für Heck-Stoßfänger 1701008
Terminal Plástico para Paragolpes Trasero 1701008

NEW

Ref	Kg	Mat	Lot
1701010	0.25		1



LATERAL PROTECTION / PROTECCIÓN LATERAL

TECHNICAL FITTINGS INSTRUCTIONS RELATED TO LATERAL PROTECTION, according to R73 reglement.

The vehicles belonging to N2, N3, O3 and O4 classes must be built and equipped, in order to offer the road users (pedestrians, cyclist...) an efficient protection against the risk of falling under a lateral part of the vehicle and slipping under the wheels.

PRESCRIPCIONES TECNICAS RELATIVAS A LA PROTECCION LATERAL, según el reglamento R73.

Los vehículos de las categorías N2, N3, O3 y O4 deben estar construidos y equipados de forma que ofrezcan a los usuarios de la carretera (peatones, ciclistas, etc.), una protección eficaz contra el riesgo de caer bajo una parte lateral del vehículo y pasar bajo las ruedas.

Accuracy to size for assembly
Cotas dimensionales a respetar para el montaje

ECE
R 73

Motorized vehicles N2 and N3 Classes / Vehículos motorizados Clases N2 y N3

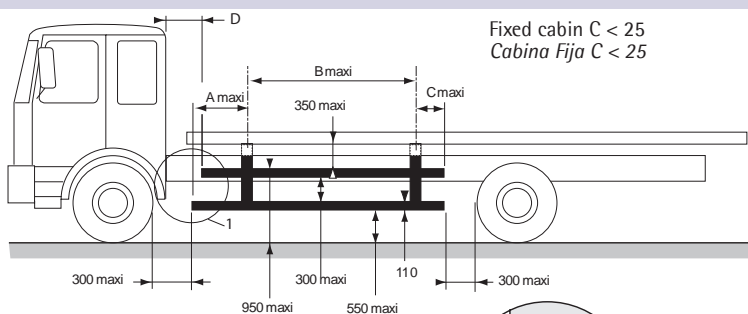

Hanging or tipping cabin C = 100
Cabina suspendida o basculante C = 100

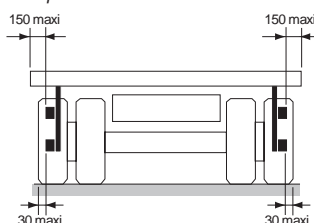

Ref.	A	B	C
1702060/62	650	3000	200
1702065/68	600	3000	200
1702067	600	3000	140
1702055	650	3000	200
1702055+1702096	260	3000	200
1702052/54 - 1702066	650	3000	200

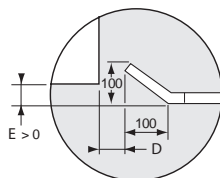

Detail 1 - Top view
Detalle 1 - Vista superior

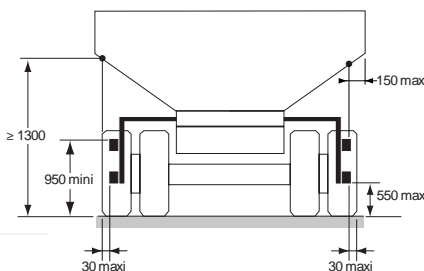

Trailers O3 and O4 Classes / Remolques Clases O3 y O4

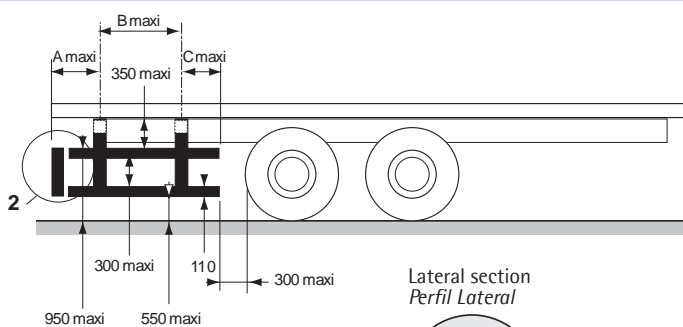
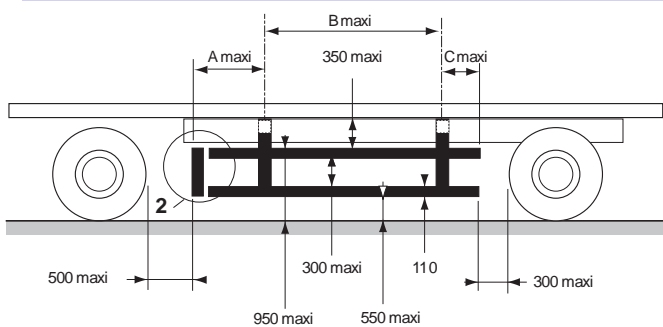

Lateral section
Perfil Lateral

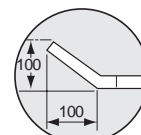

Detail 2 - Top view
Detalle 2 - Vista superior

Semitrailer O3 and O4 Classes / Semirremolques Clases O3 y O4

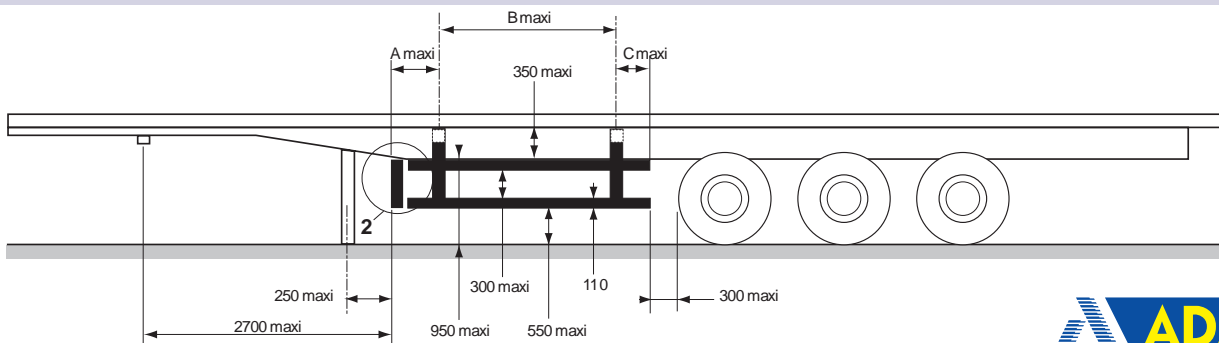



SIDE ANTI CRASH / SEITLICHE SCHUTZVORRICHTUNG / PARAGOLPES LATERAL LATERAL PROTECTION / PROTECCIÓN LATERAL

PLYWOOD BOARDS-CHASSIS / BODENPLATTEN-FAHRGESTELLZUBEHÖR / TABLEROS-CHASIS



E₉



R73 Regulation / Reglamento R73

- R01/02 *3035*01
- R01/02 *3036*01
- R01/02 *3037*01
- R01/02 *1203*00

2101096+2101134+2102102

- 1702060/62
- 1702065/68
- 1702067
- 1702052/54
- 1702066 **NEW**

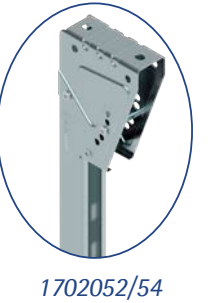

- ALU ANOD 1702020/24/25/26/30/32/34
- ALU RAW 1702038/41/42/43/47

1702082

1702086

1702010 ANOD
1702002 RAW

*Homologations are only valid with the complete kit of ADAICO components
Homologaciones válidas únicamente con el kit completo de componentes ADAICO

	Homologación Homologation (E9*73R) E ₉	Soporte Support	Perfil Hor. Profilé Hor.	Tapa H. Embout H.	Perfil Ver. Profilé Ver.	Tapa V. Embout V.	Kit fijación Set fixation
	R01/02 *3035*01	1702060/62	2x Anodizado Anodized: ANOD 1702020 1702024 1702025 1702026 1702030 1702032 1702034	2x 1702082	1x Anodizado Anodized: ANOD 1702010 Bruto Raw: RAW 1702002	2x 1702086	4x 2101096 + 2101134 + 2102102
	R01/02 *3036*01	1702065/68					
	R01/02 *1203*00	1702052/54					
	R01/02 *1207*00	1702059-52/54	Bruto Raw: RAW 1702038 1702041 1702042 1702043 1702047	2x 1702082	1x 1702010 o 1702002 *2x 1702012 (Abatible Pliable)	2x o *4x 1702086	2101096/1134/2102 + *1702096
	R01/02 *1208*00	1702059-66					
	R01/02 *1202*00	1702055 + 0106080 	Bruto Raw: RAW 1702051/53 	2x 1702082	1x 1702010 o 1702002	2x 1702086	4x 2101096 2101134 2102102
	NEW						

Horizontal Anticrash Anodized Aluminium Profile Unterfahrerschutz Profil Horizontal Aluminium Eloxiert Perfil Hor. Antiempotramiento de Aluminio Anodizado

Ref	Kg	Mat	Sup/Finish Acabado	Pos	A	Lot
1702025	1.39		Anod		1,2 m.	1
1702026	2.9		Anod		2,5 m.	2
1702030	3.48		Anod		3 m.	2
1702020	4.06		Anod		3,5 m.	2
1702032	4.64		Anod		4 m.	2
1702034	5.8		Anod		5 m.	2
1702024	6.95		Anod		6 m.	2

Adhesive label R73 available (only complete ADAICO Lateral Protection Device)
Etiqueta adhesiva R73 disponible (solo Kit Antiempotramiento completo ADAICO)
89/297/EEC Directive | ECE Regulation R73

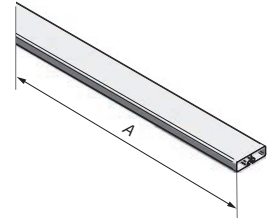
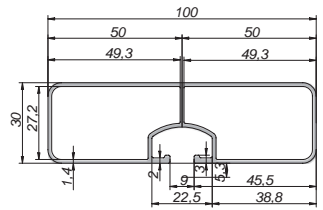

Horizontal Anticrash Raw Aluminium Profile Unterfahrerschutz Profil Horizontal Rohaluminium Perfil Horizontal Antiempotramiento de Aluminio Bruto

Ref	Kg	Mat	Pos	A	Lot
1702047	3.48			3 m.	2
1702041	4.06			3,5 m.	2
1702038	4.64			4 m.	2
1702042	6.37			5,5 m.	2
1702043	8.11			7 m.	2

89/297/EEC Directive | ECE Regulation R73

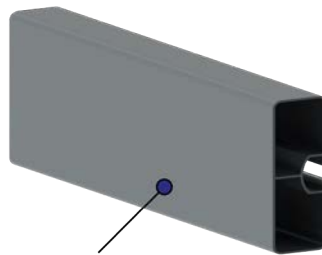

Aluminio Bruto / Mill Finish Aluminium

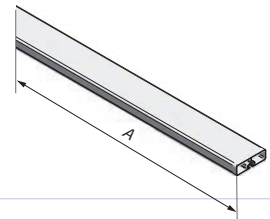
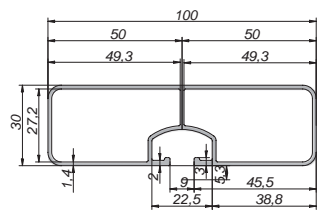

Vertical Anticrash Anodized Aluminium Profile Unterfahrerschutz Profil Vertikal Aluminium Eloxiert Perfil Antiempotramiento Vertical Aluminio Anodizado

Ref	Kg	Mat	Sup/Finish Acabado	Pos	Lot
1702010	0.86		Anod		2

89/297/EEC Directive | ECE Regulation R73

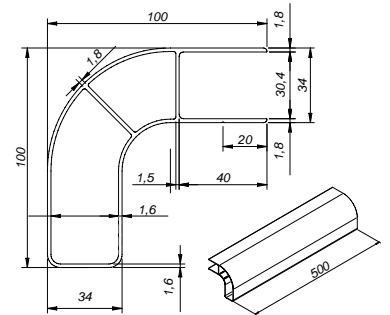

Vertical Anticrash Profile Raw Aluminium Unterfahrerschutz Profil Vertikal, Pressblank Perfil Antiempotramiento Vertical Aluminio Bruto

Ref	Kg	Mat	Pos	Lot
1702002	0.86			1

89/297/EEC Directive | ECE Regulation R73



Bruto / Raw

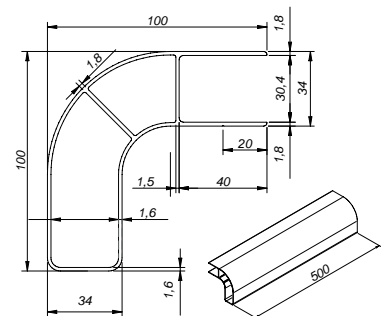



SIDE ANTI CRASH / SEITLICHE SCHUTZVORRICHTUNG / PARAGOLPES LATERAL

PLYWOOD BOARDS-CHASSIS / BODENPLATTEN-FAHRGESTELLZUBEHÖR / TABLEROS-CHASIS

Cap for Horizontal Anti Crash Profile
Endkappen für Unterfahrschutz Profil Horizontal
Terminales Perfil Antiempotramiento Horizontal

Ref	Kg	Mat	Lot	Pack
1702082	0.1		1	8
89/297/EEC Directive ECE Regulation R73				

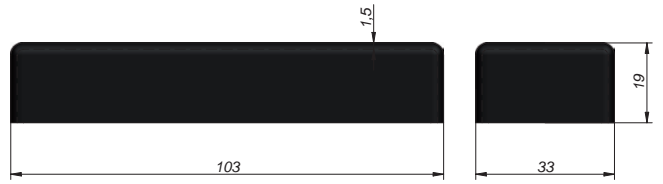
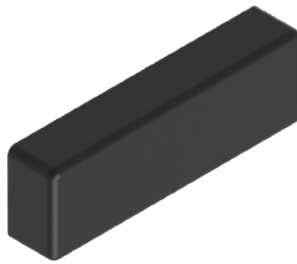

Plastic Cap for Vertical Anti Crash Profile
Endkappen für Unterfahrschutz Profil Vertikal
Terminales Perfil Antiempotramiento Vertical

Ref	Kg	Mat	Lot	Pack
1702086	0.17		1	4
89/297/EEC Directive ECE Regulation R73				

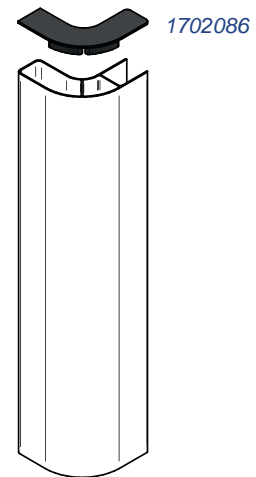
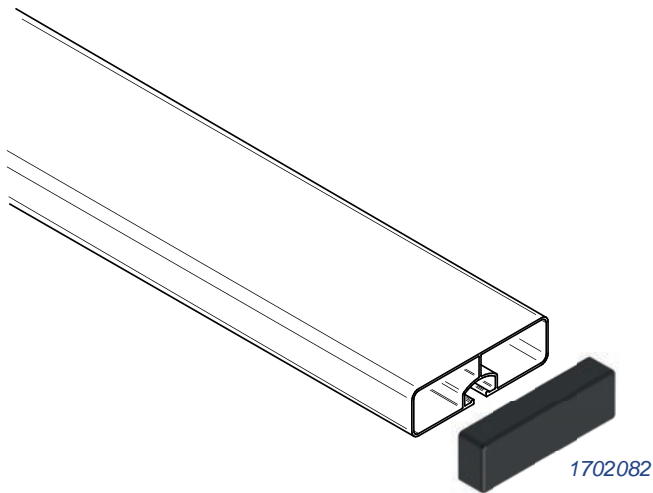
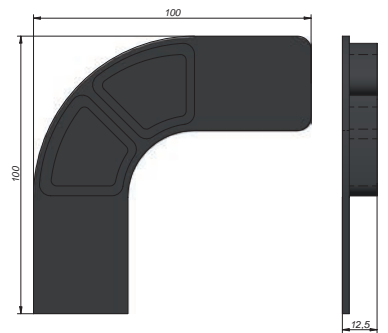

Installation Kit
Einbausatz
Kit de Instalación

Ref	Kg	Mat	Sup/Finish Acabado	Metric	Article	Lot	Pack
2101096	0.24	STEEL	Zn	M8	Bolt Tornillo	1	16
2102102	0.16	STEEL		M8	Nut Tuerca	1	16
2101134	0.04				Plate Pletina	1	4
89/297/EEC Directive ECE Regulation R73							



Instalación Kit de Fijación
Installation Fixing Kit

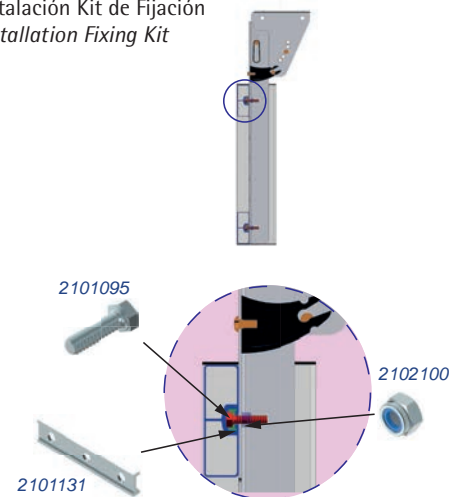

LIGHT Anticrash Support Unterfahrerschutz Halterung LEICHT Soporte Abatible Antiempotramiento Lateral ALIGERADO

Ref	Kg	Mat	Sup/Finish Acabado	A	Thickn. Espesor	Lot
1702052	1.8	STEEL	Zn	550	1.5	2
1702054	2	STEEL	Zn	700	1.5	2

Approval R73 marking (valid only for complete ADAICO Lateral Protection Device)
Marcado con Homologación R73 (válido solo para Kit Antiempotramiento completo ADAICO)
ECE Regulation R73

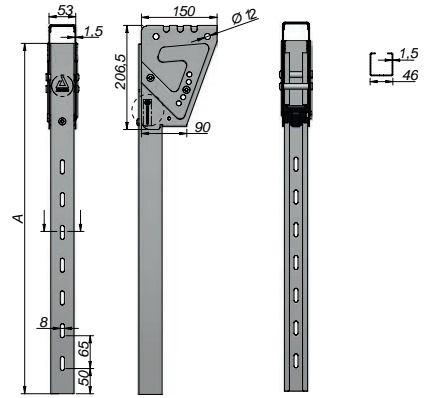

LIGHT Anticrash Support with Pin Unterfahrerschutz Halterung LEICHT mit Splint Soporte Antiempotramiento Lateral ALIGERADO c/Pasador

NEW

Ref	Kg	Mat	Sup/Finish Acabado	Thickn. Espesor	E-mark	Lot
1702066	2.1	STEEL	Zn	1.5	E ₉	1

Approval R73 marking (valid only for complete ADAICO Lateral Protection Device)
Marcado con Homologación R73 (válido solo para Kit Antiempotramiento completo ADAICO)
ECE Regulation R73

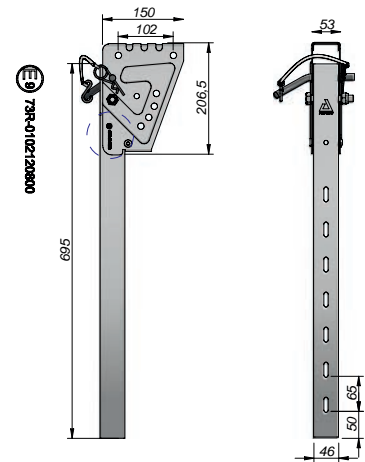

Anticrash Support Unterfahrerschutz Halterung, klappbar Soporte Abatible Antiempotramiento Lateral

Ref	Kg	Mat	Sup/Finish Acabado	A	B	C	D	Thickn. Espesor	E-mark	Lot
1702060	3.39	STEEL	Zn	700	150	57	208	2.5	E ₉	2
1702062	2.25	STEEL	Zn	550	130	50	168	2.5	E ₉	2

Approval R73 marking (valid only for complete ADAICO Lateral Protection Device)
Marcado con Homologación R73 (válido solo para Kit Antiempotramiento completo ADAICO)
ECE Regulation R73

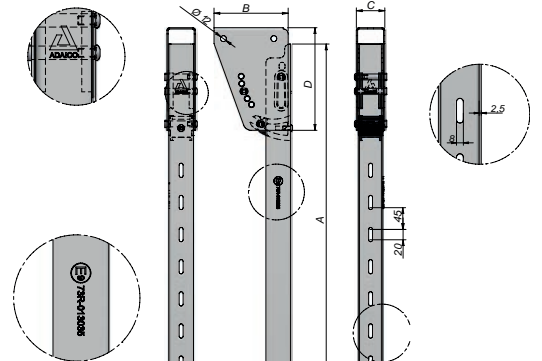

Zinc Plated Steel Anticrash Support with Pin Unterfahrerschutz Halterung, klappbar Verzinkt, mit Splint Soporte Abatible Antiemp. Lateral Cincado c/Pasador

Ref	Kg	Mat	Sup/Finish Acabado	Thickn. Espesor	E-mark	Lot
1702068	3.7	STEEL	Zn	2.5	E ₉	2

Approval R73 marking (valid only for complete ADAICO Lateral Protection Device)
Marcado con Homologación R73 (válido solo para Kit Antiempotramiento completo ADAICO)
ECE Regulation R73

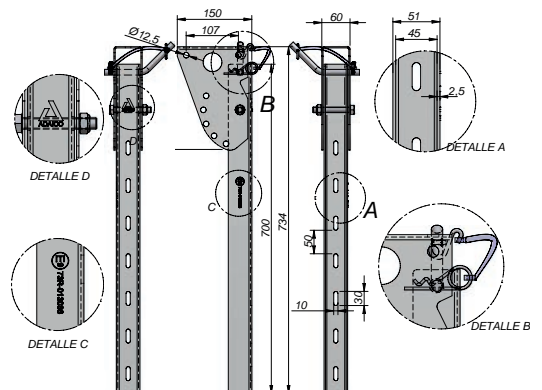



SIDE ANTI CRASH / SEITLICHE SCHUTZVORRICHTUNG / PARAGOLPES LATERAL

PLYWOOD BOARDS-CHASSIS / BODENPLATTEN-FAHRGESTELLZUBEHÖR / TABLEROS-CHASSIS

Galvanized Steel Anticrash Support with Pin
Unterfahrerschutz Halterung, klappbar Feuerverzinkt, mit Splint
Soporte Abatible Antiemp. Lateral Galvanizado c/Pasador

Ref	Kg	Mat	Sup/Finish Acabado	Thickn. Espesor	Emark	Lot
1702065	2.24	STEEL	Galv	3	E ₉	1

ECE Regulation R73

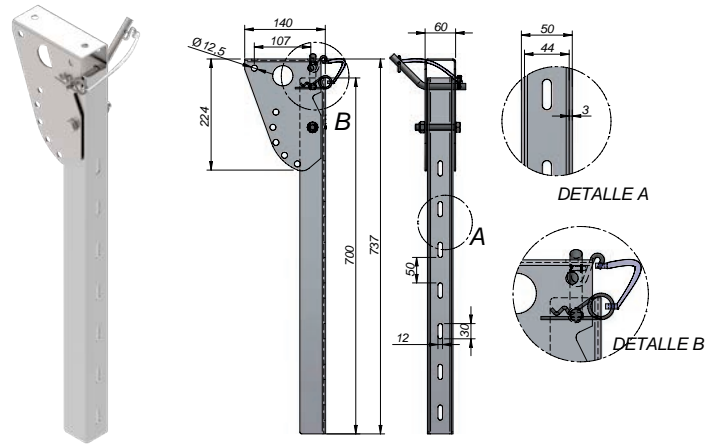

Anticrash Support Pin
Splint für Unterfahrerschutz Halterung
Pasador para Soporte Antiempotramiento

Ref	Kg	Mat	Lot
1702094	0.1	STEEL	1

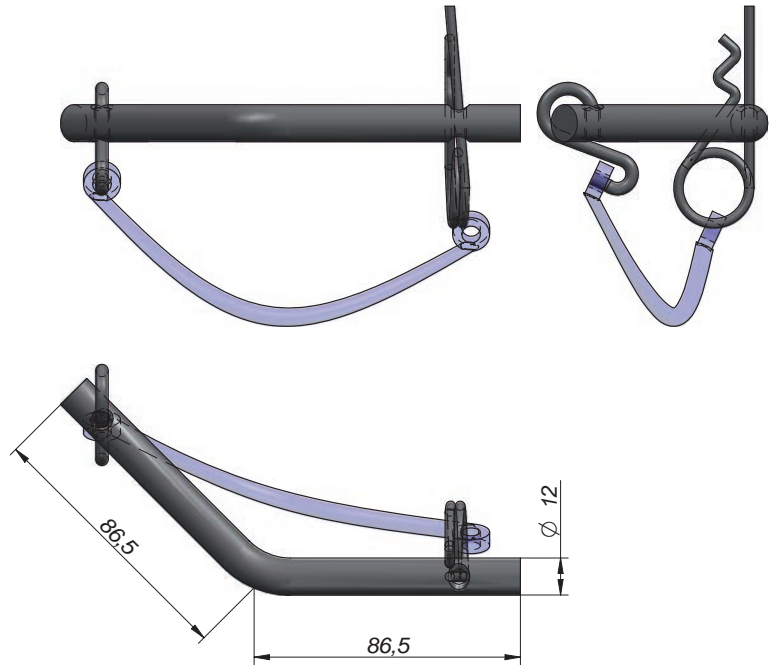

FIXED LATERAL PROTECTION SYSTEM SISTEMA DE PROTECCIÓN LATERAL FIJO

R73 Regulation / Reglamento R73



R01/02 *1207*00
R01/02 *1208*00



Rough Steel Adjustable Support
Querträger für Unterfahrschutz Halter
Soporte Regulable Antiempotramiento Lateral

NEW

Ref	Kg	Mat	E-mark	Lot
1702059	4.7	STEEL	E ₉	1

ECE Regulation R73

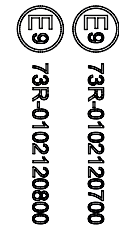
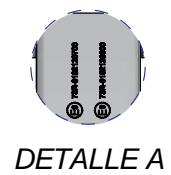
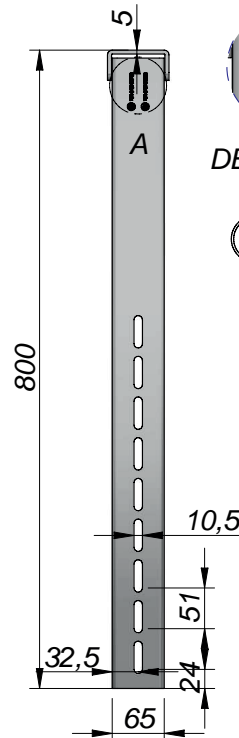
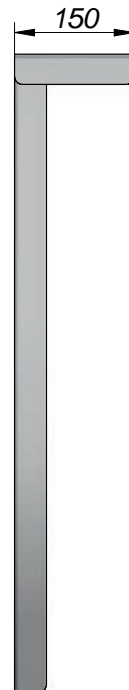
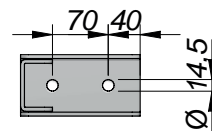



PLYWOOD BOARDS-CHASSIS / BODENPLATTEN-FAHRGESTELLZUBEHÖR / TABLEROS-CHASIS

FIXED LATERAL PROTECTION SYSTEM SISTEMA DE PROTECCIÓN LATERAL FIJO

R73 Regulation / Reglamento R73



R01/02 *1202*00

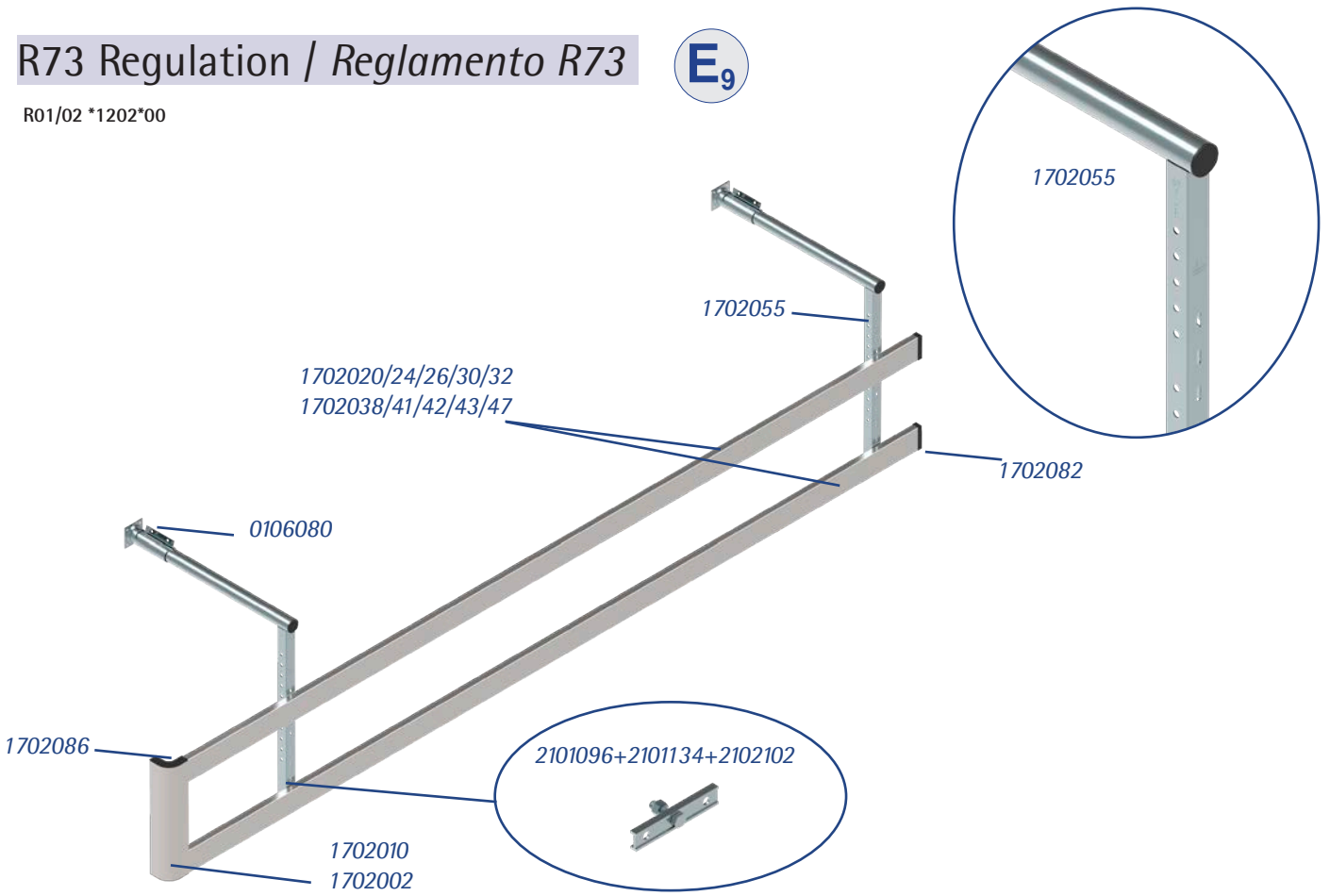

FOLDING OPTION OPCION ABATIBLE

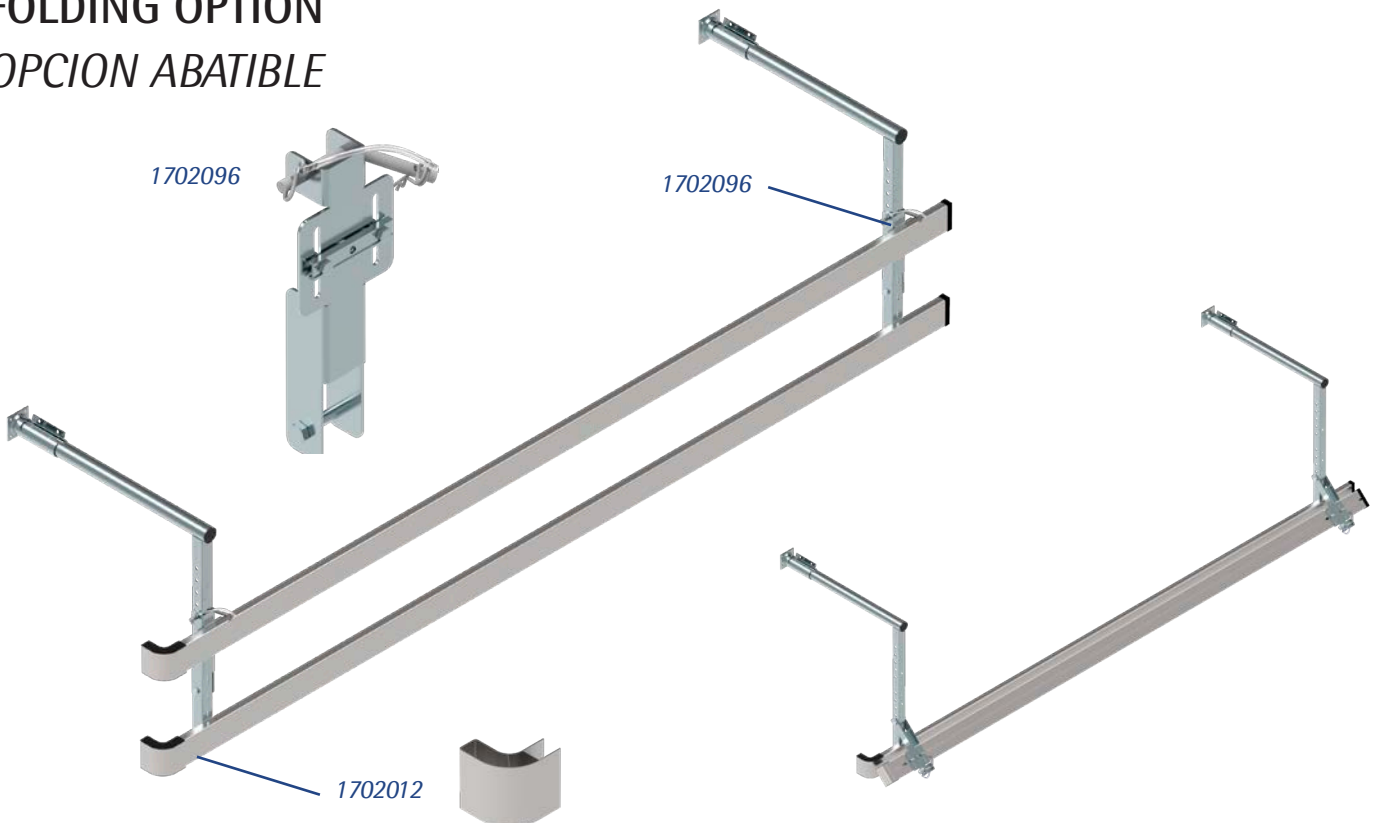

Galvanized Steel Anticrash Fix Support (Ø54)
 Feuerverzinkt für Seitlichen Anfahrerschutz (Ø54)
 Soporte Paraciclistas Lateral Fijo Galvanizado (Ø54)

Ref	Kg	Mat	Sup/Finish Acabado	Emark	Lot
1702055	4	STEEL	Galv	E ₉	1

ECE Regulation R73

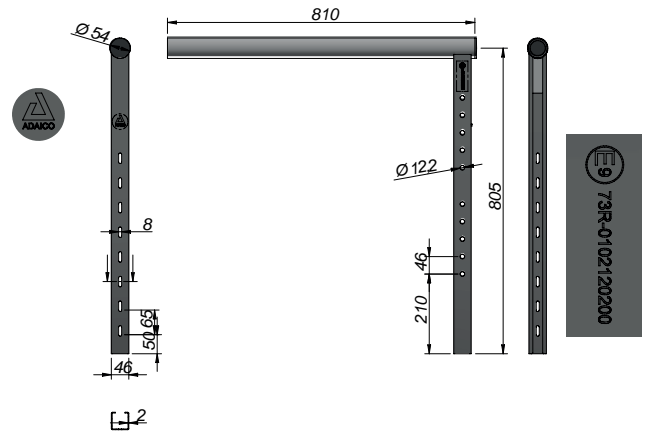

PLYWOOD BOARDS-CHASSIS / BODENPLATTEN-FAHRGESTELLZUBEHÖR / TABLEROS-CHASIS

Zinc Plated Folding Fixation Set for 1702055
 Verzinkt Befestigungseinsatz für 1702055
 Kit abatible para 1702055 Acero Cincado

Ref	Kg	Mat	Sup/Finish Acabado	Emark	Lot
1702096	1.2	STEEL	Zn	E ₉	1

ECE Regulation R73

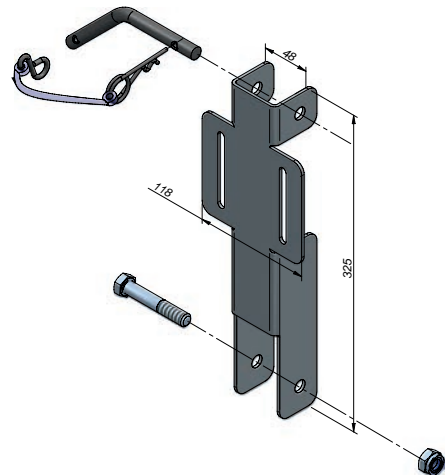
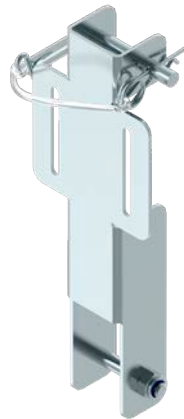

Vertical Anticrash Anodized Alu Profile L=0,1m.
 Profil Vertikal Aluminium Eloxiert L=0,1m.
 Perfil Vertical Aluminio Anodizado L=0,1m.

Ref	Kg	Mat	Sup/Finish Acabado	Pos	Lot	Pack
1702012	0.36	Al	Anod	↑	1	2

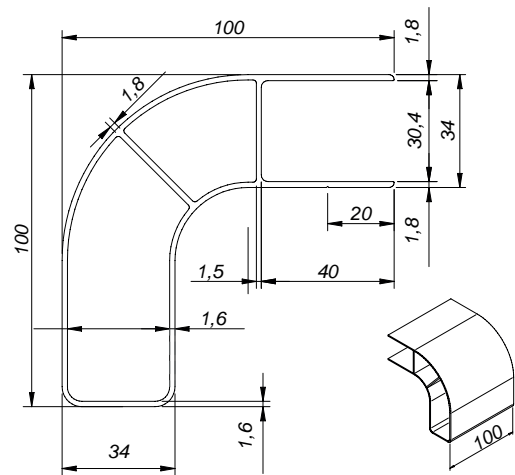
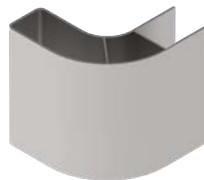

Zinc Plated Support Base (Ø54)
 Anschraubflansch (Ø54) Verzinkt
 Base Soporte (Ø54) Cincado

Ref	Kg	Mat	Sup/Finish Acabado	Col	Ø	Thickn. Espesor	Lot
0106080	0.92	STEEL	Zn	Ag	54	2.5	2

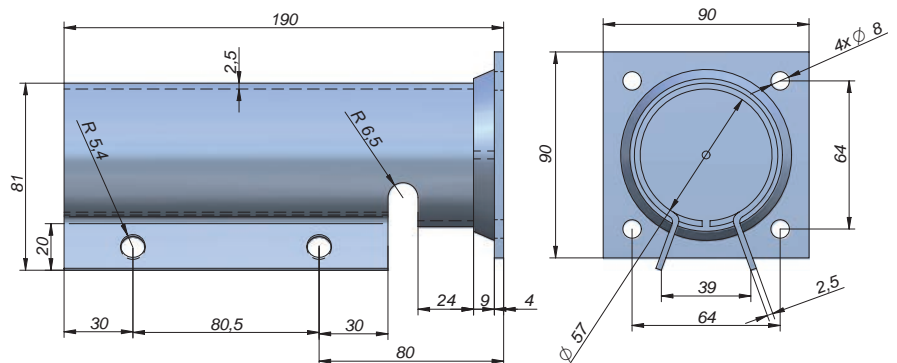



SIDE ANTI CRASH / SEITLICHE SCHUTZVORRICHTUNG / PARAGOLPES LATERAL

LATERAL PROTECTION SYSTEM WITH STEP SISTEMA DE PROTECCIÓN LATERAL CON ESCALÓN

NEW

NEW 1702051



NEW 1702053

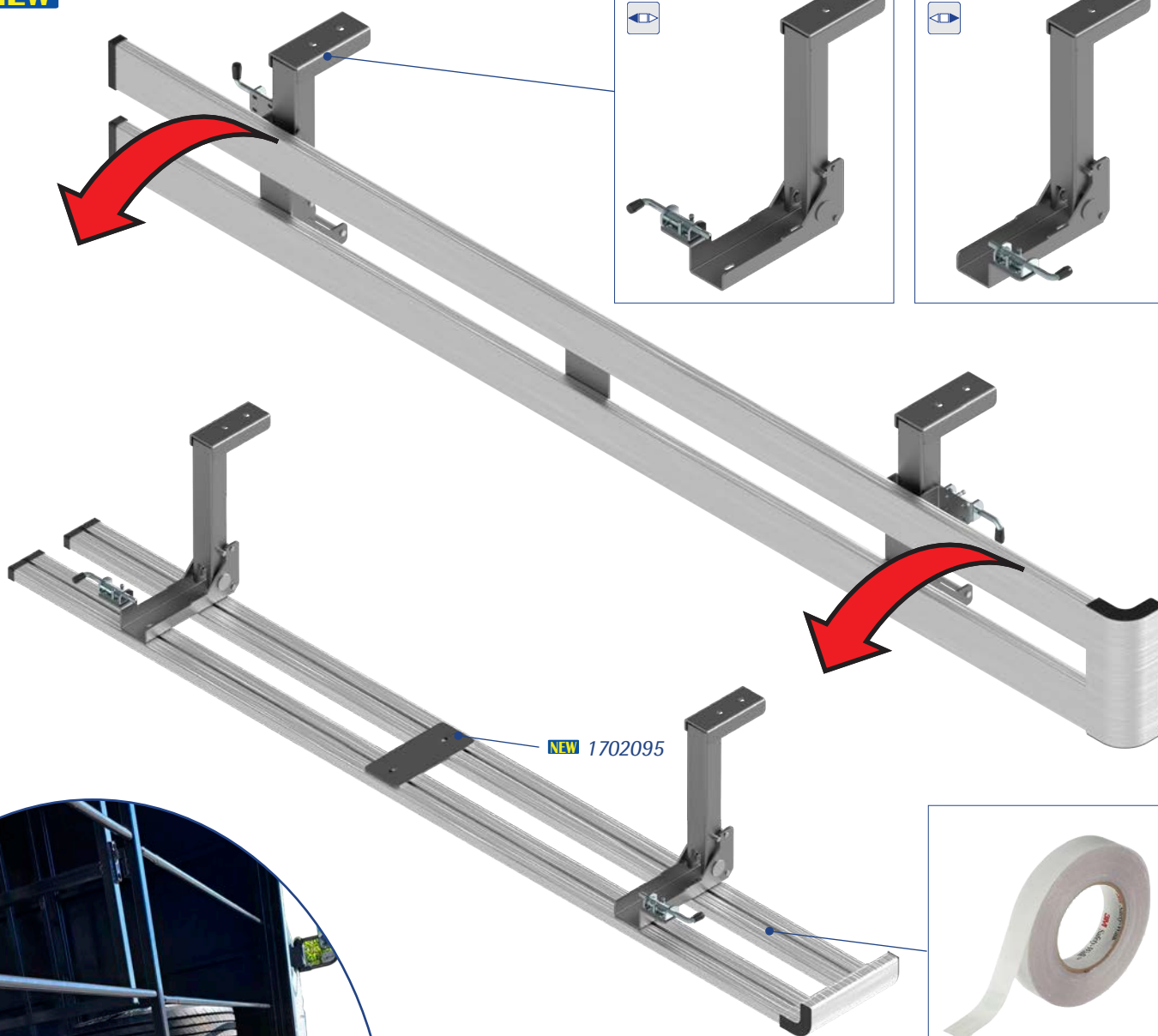

NEW 1702095



NEW 7206010

Antislip Tape
Cinta Antideslizante





Galvanized Steel Adjustable Support with Step
 Querträger für Unterfahrerschutz Halter Verzinkt mit Stufen
 Soporte Regulable Lateral Galvanizado c/Escalón

Ref	Kg	Mat	Sup/Finish Acabado	Lot
1702051	6.55	STEEL	Galv	1
1702053	6.55	STEEL	Galv	1

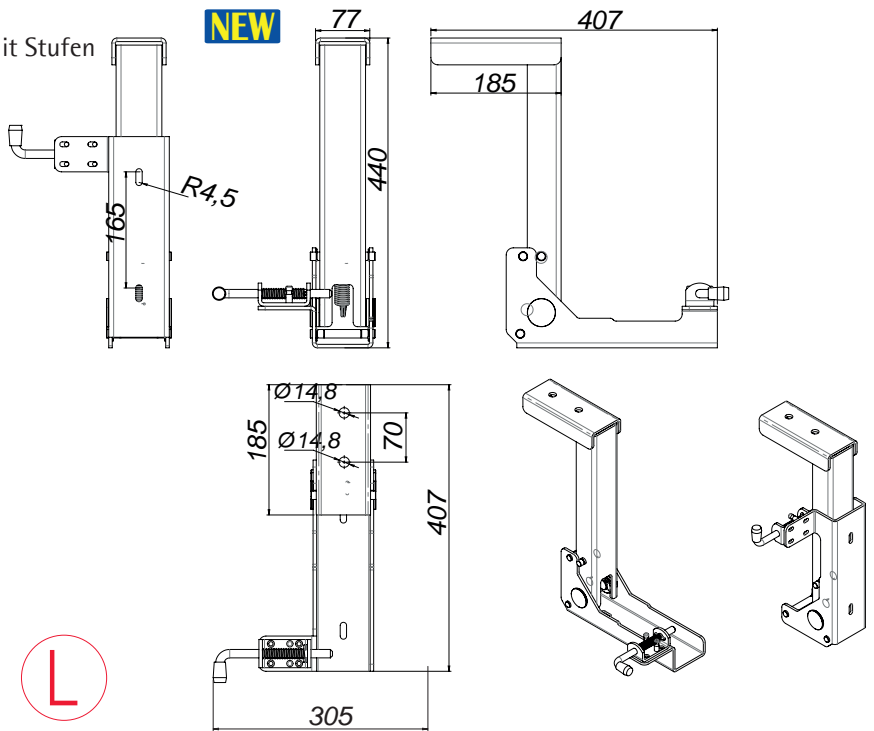

Antislip Tape 18,3m.x25,4mm
 Anti-Rutsch-Klebeband 18,3m.x25,4mm
 Cinta Antideslizante 18,3m.x25,4mm

Ref	Kg	Mat	Thickn. Espesor	Lot
7206010	0.34	STEEL	0.7	1

3M Safety-Walk™ | Minimum application temperature: 4°C | Do not wear barefoot
 3M Safety-Walk™ | Temperatura mínima de aplicación: 4°C | No usar descalzo

NEW



Reinforcement Plate for Side Anti Crash with Step
 Verstärkungsplatte für Seitliche Schutzvorrichtung
 Placa de Refuerzo para Antiempotramiento Lateral Escalón

Ref	Kg	Mat	Lot
1702095	1	Galv	1



NEW

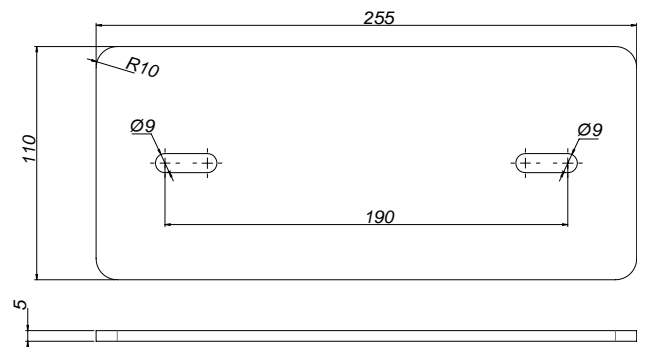

PLYWOOD BOARDS-CHASSIS / BODENPLATTEN-FAHRGESTELLZUBEHÖR / TABLEROS-CHASSIS



BUMPER END CAP / STOSSSTANGENENDSTÜCK / TOPE PARAGOLPES

PLYWOOD BOARDS-CHASSIS / BODENPLATTEN-FAHRGESTELLZUBEHÖR / TABLEROS-CHASSIS

Rubber Bumper Profile 2.600x125
Gummi-Rammschutzprofil 2.600x125
Perfil Paragolpes Goma 2.600x125

Ref	Kg	Mat	Hard. Dureza	Lot
1703010	35.1	EPDM	70° ± 5° Shore	1

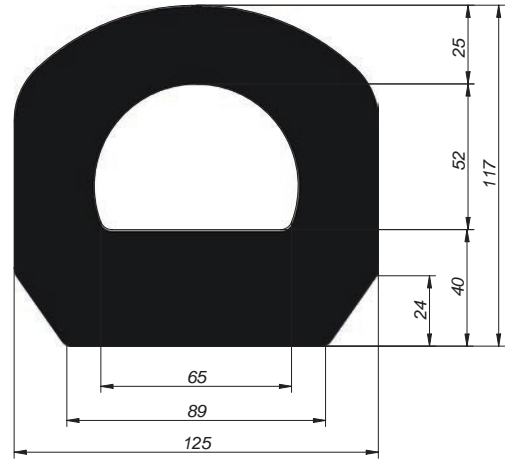
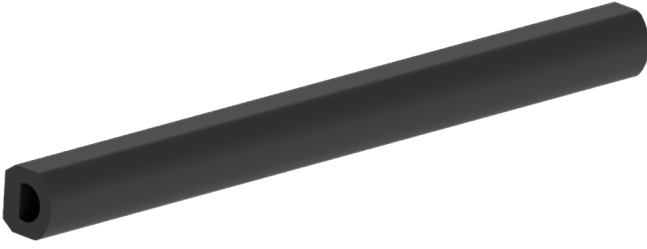

Rubber Bumper Profile 2.600x122
Gummi-Rammschutzprofil 2.600x122
Perfil Paragolpes Goma 2.600x122

Ref	Kg	Mat	Hard. Dureza	Lot
1703015	22.1	EPDM	70° ± 5° Shore	1

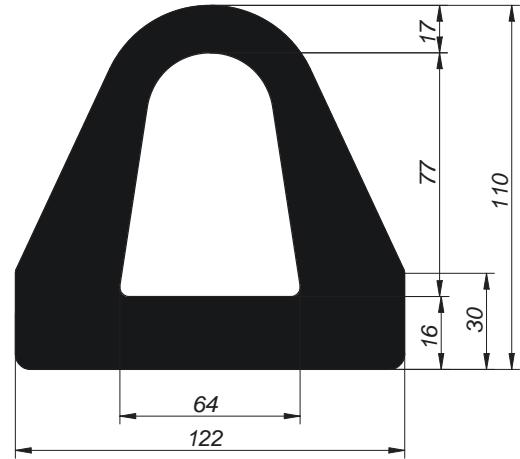
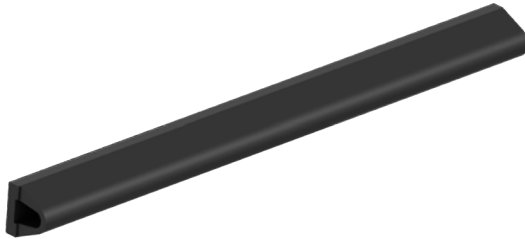

Rubber Bumper Profile 2.500x107
Gummi-Rammschutzprofil 2.500x107
Perfil Paragolpes Goma 2.500x107

Ref	Kg	Mat	Hard. Dureza	Lot
1703020	16.25	EPDM	70° ± 5° Shore	1

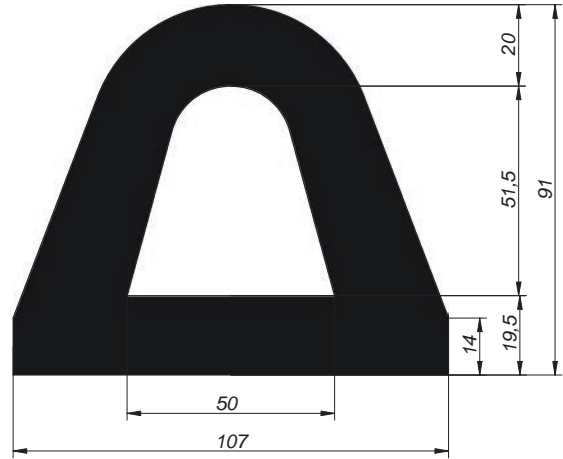
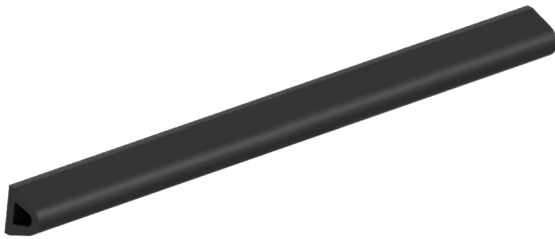

Rubber Bumper Profile 2.500x80
Gummi-Rammschutzprofil 2.500x80
Perfil Paragolpes PVC 2.500x80

Ref	Kg	Mat	Hard. Dureza	Lot
1703025	9.5	EPDM	70° ± 5° Shore	1

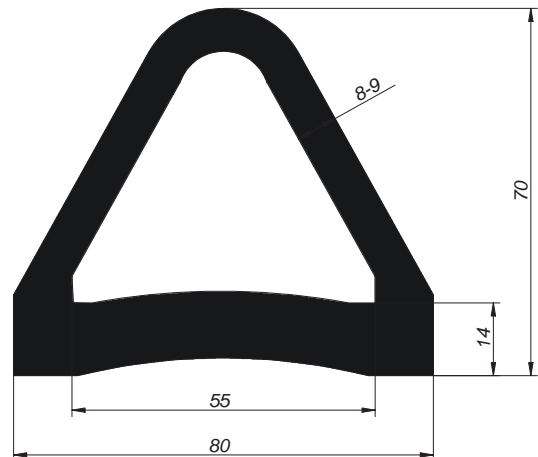
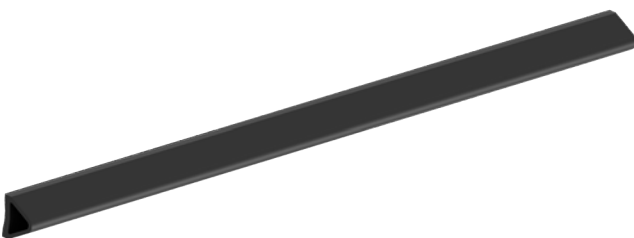

Rubber Bumper Profile 2.500x70
 Gummi-Rammschutzprofil 2.500x70
 Perfil Paragolpes Goma 2.500x70

Ref	Kg	Mat	Hard. Durezza	Lot
1703030	7.5	EPDM	70° ± 5° Shore	1

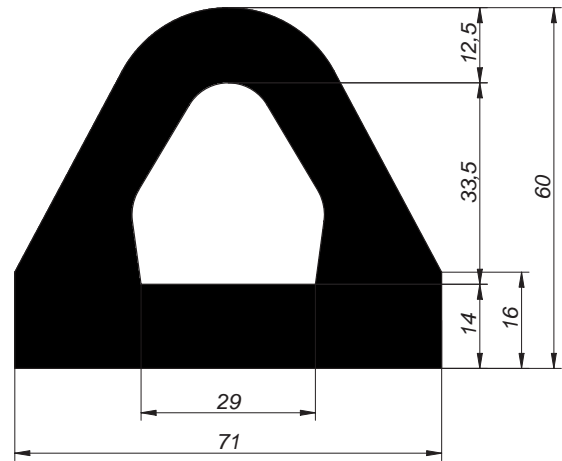
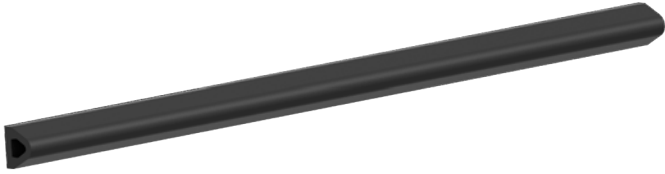

ADA-SLIDER PVC Bumper Profile L=3.000
 PVC-Rammschutzleiste ADA-SLIDER L=3000
 Tope Perfil Paragolpes ADA-SLIDER L=3.000 PVC

Ref	Kg	Mat	Lot
1703064	3.22	PVC	1

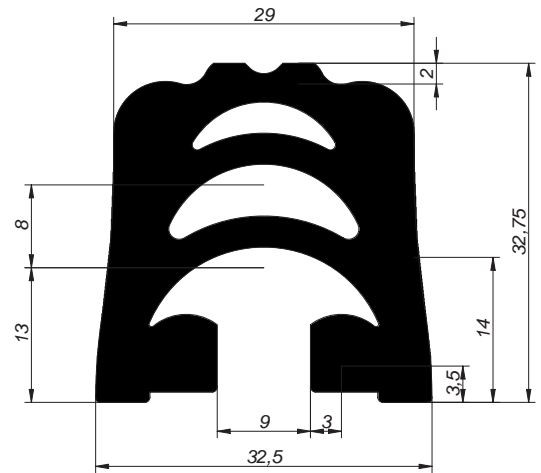

Rubber Bumper 125x80x87
 Gummi-Rammpuffer 125x80x87
 Tope 125x80x87 Goma

Ref	Kg	Mat	Lot
1703158	0.98		2

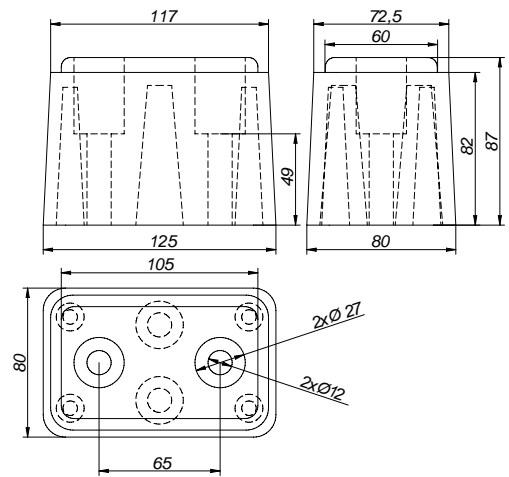
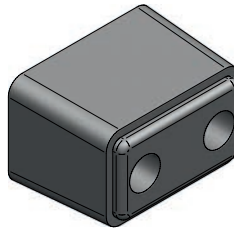
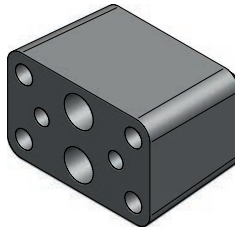

Rubber Bumper 195x80x80
 Gummi-Rammpuffer 195x80x80
 Tope 195x80x80 Goma

Ref	Kg	Mat	Lot
1703162	1.2		2

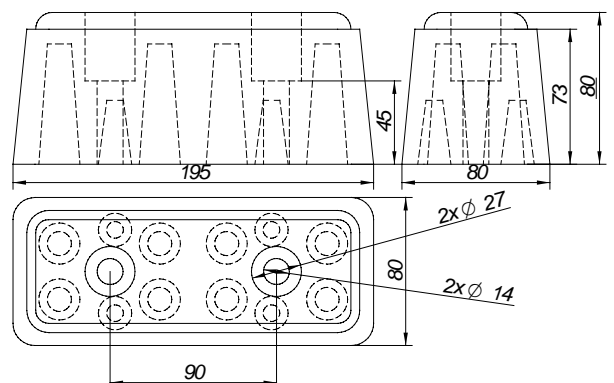
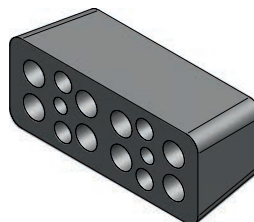
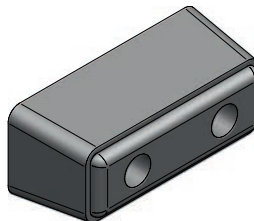

BUMPER END CAP / STOSSSTANGENENDSTÜCK / TOPE PARAGOLPES

PLYWOOD BOARDS-CHASSIS / BODENPLATTEN-FAHRGESTELLZUBEHÖR / TABLEROS-CHASIS

Rubber Bumper 200x52x50
Gummi-Rammpuffer 200x52x50
Tope 200x52x50 Goma

Ref	Kg	Mat	Lot
1703160	0.83		1

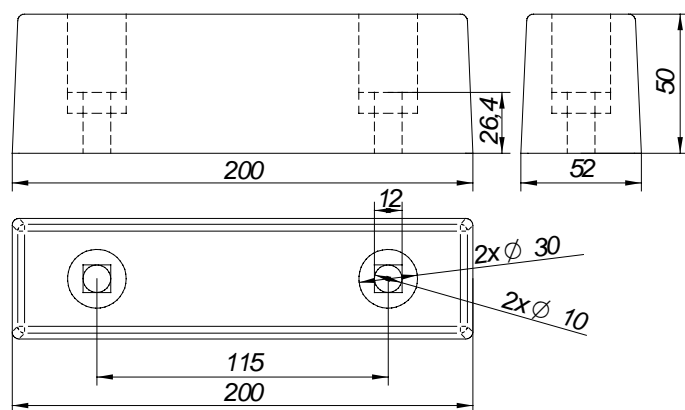
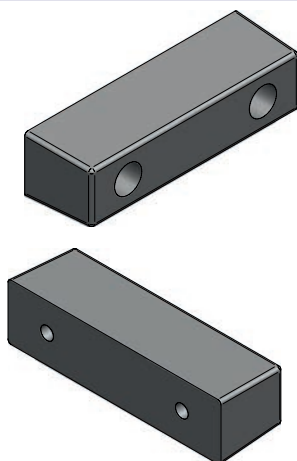

Rubber Bumper 210x50x55
Gummi-Rammpuffer 210x50x55
Tope 210x50x55 Goma

Ref	Kg	Mat	Lot
1703164	0.55		1

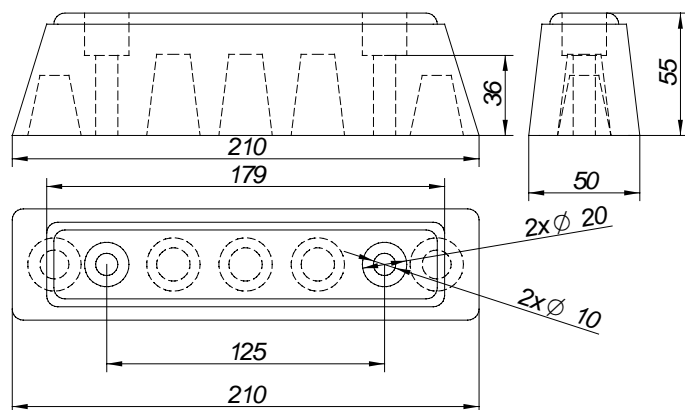
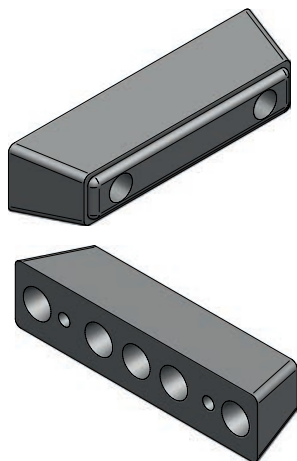

Rubber Bumper 245x80x90
Gummi-Rammpuffer 245x80x90
Tope 245x80x90 Goma

Ref	Kg	Mat	Lot
1703120	1.81		1

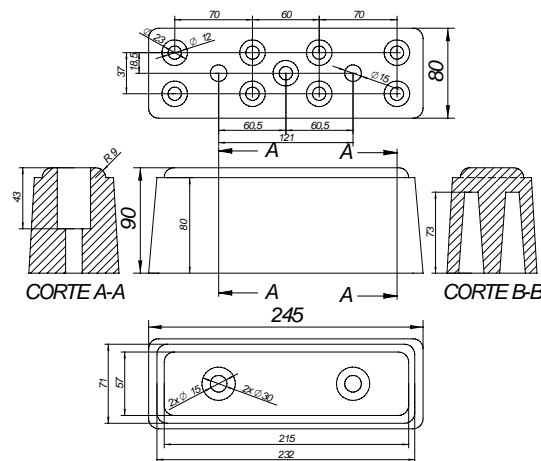
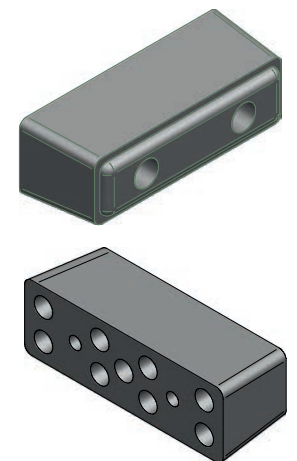

Rubber Bumper 310x35x60
Gummi-Rammpuffer 310x35x60
Tope 310x35x60 Goma

Ref	Kg	Mat	Lot
1703150	0.93		1

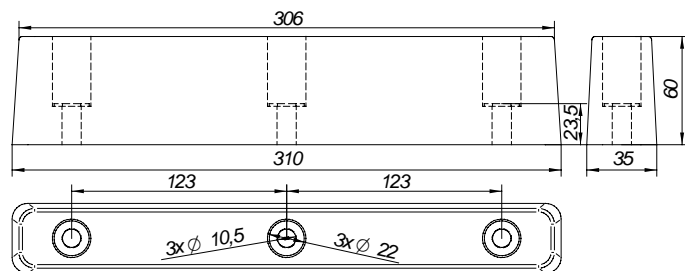

Rubber Bumper 360x100x103
 Gummi-Rammpuffer 360x100x103
 Tope 360x100x103 Goma

Ref	Kg	Mat	Lot
1703175	3.5		1

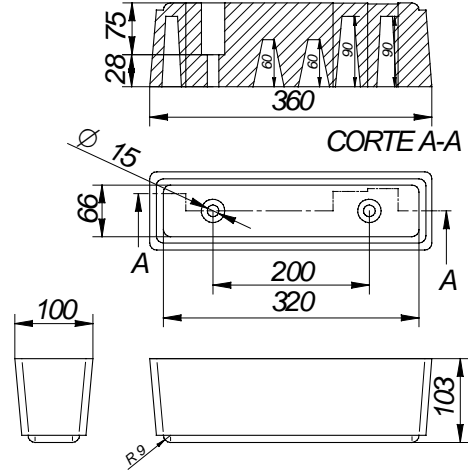
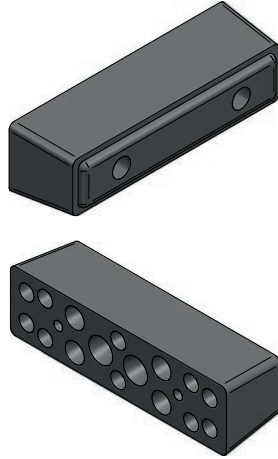

Rubber Bumper 430x135x100
 Gummi-Rammpuffer 430x135x100
 Tope 430x135x100 Goma

Ref	Kg	Mat	Lot
1703190	5.84		1

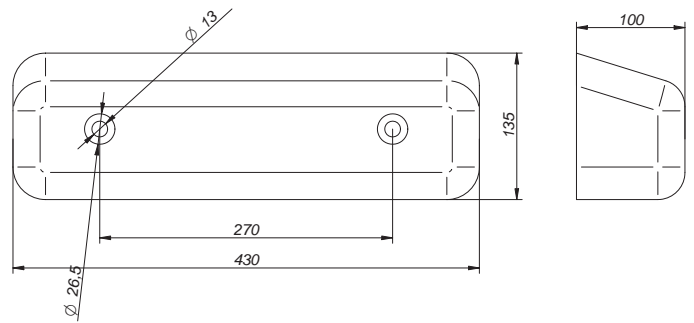
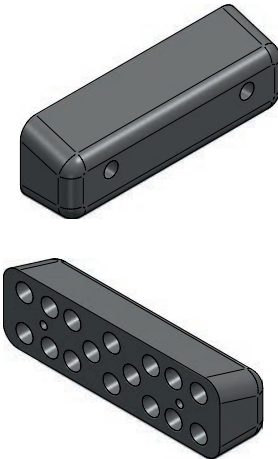

Rubber Bumper 490x80x83
 Gummi-Rammpuffer 490x80x83
 Tope 490x80x83 Goma

Ref	Kg	Mat	Lot
1703170	4.37		1

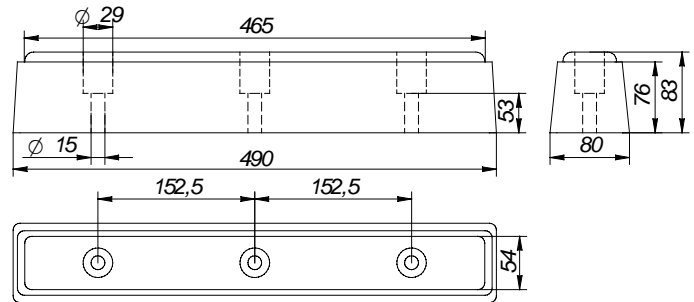
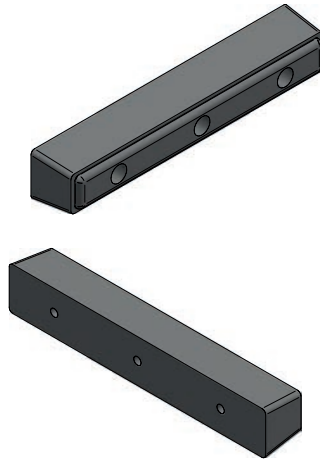

Rubber Bumper 595x100x120
 Gummi-Rammpuffer 595x100x120
 Tope 595x100x120 Goma

Ref	Kg	Mat	Lot
1703172	7.4		1

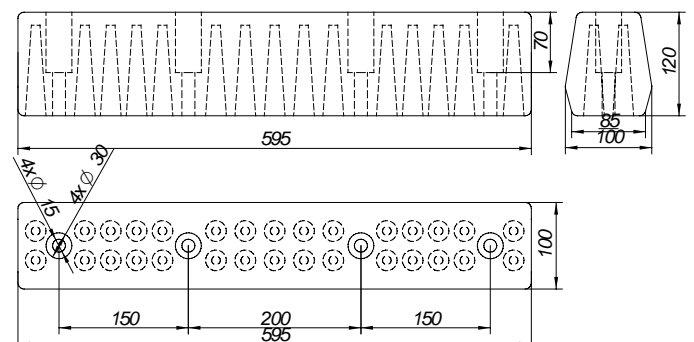
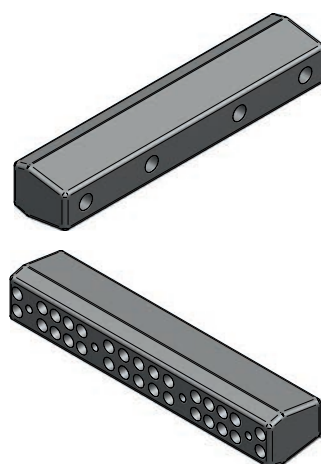



BUMPER END CAP / STOSSSTANGENENDSTÜCK / TOPE PARAGOLPES

PLYWOOD BOARDS-CHASSIS / BODENPLATTEN-FAHRGESTELLZUBEHÖR / TABLEROS-CHASSIS

Rubber Bumper 1000x85x95
Gummi-Rammpuffer 1000x85x95
Tope 1000x85x95 Goma

Ref	Kg	Mat	Lot
1703180	6.02		1

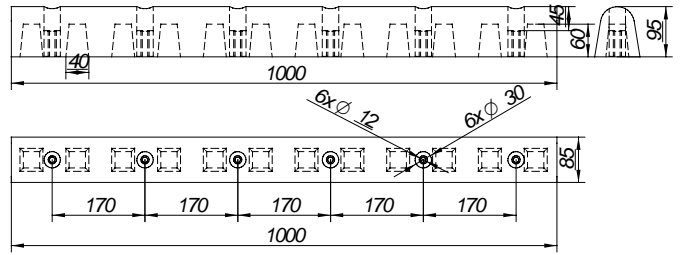

Rubber Bumper 163x125x76
Gummi-Rammpuffer 163x125x76
Tope 163x125x76 Goma

Ref	Kg	Mat	Lot
1703130	1.8		1

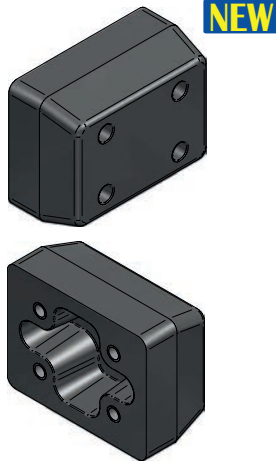

NEW

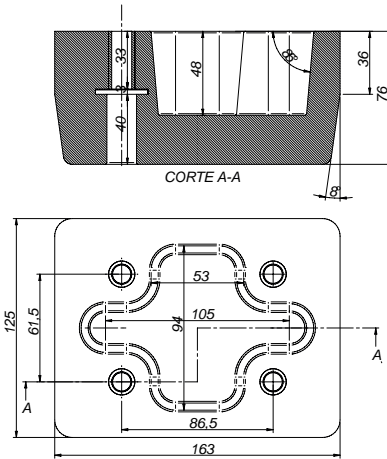

Rubber Bumper 374x65x70
Gummi-Rammpuffer 374x65x70
Tope 374x65x70 Goma

Ref	Kg	Mat	Lot
1703132	1.7		1

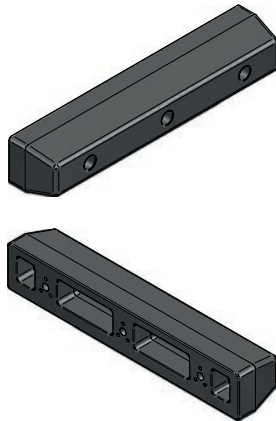

NEW

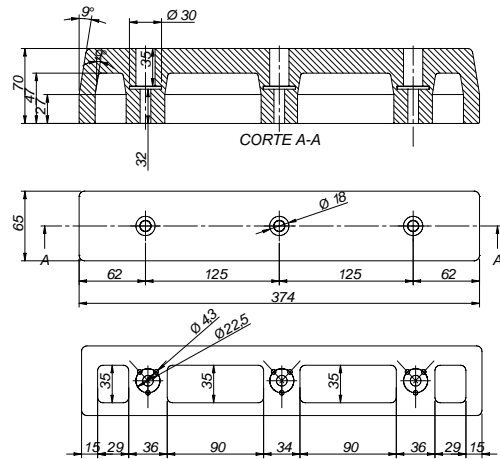

Rubber Bumper 158x107x86
Gummi-Rammpuffer 158x107x86
Tope 158x107x86 Goma

Ref	Kg	Mat	Lot
1703166	1.3		1

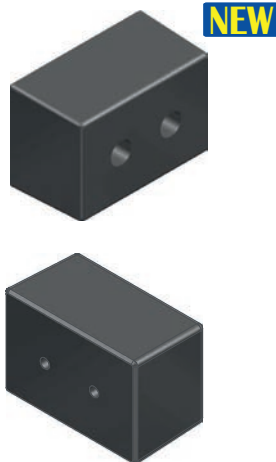

NEW

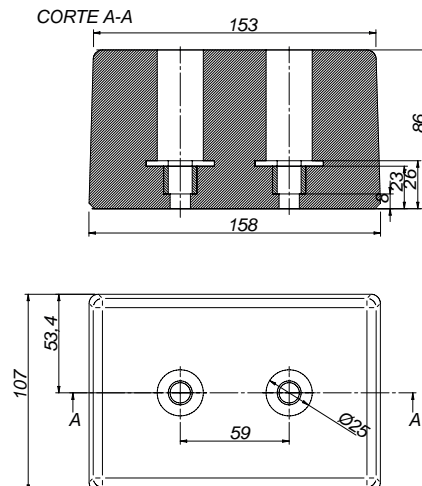

Rubber Bumper 540x120x65
 Gummi-Rammpuffer 540x120x65
 Tope 540x120x65 Goma

NEW

Ref	Kg	Mat	Lot
1703168	6.73		1

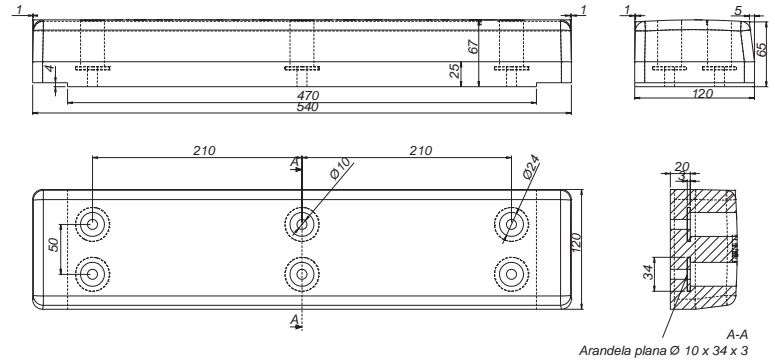

Rubber Bumper 430x155X89
 Gummi-Rammpuffer 430x155X89
 Tope 430x155X89 Goma

NEW

Ref	Kg	Mat	Lot
1703192	4.2		1

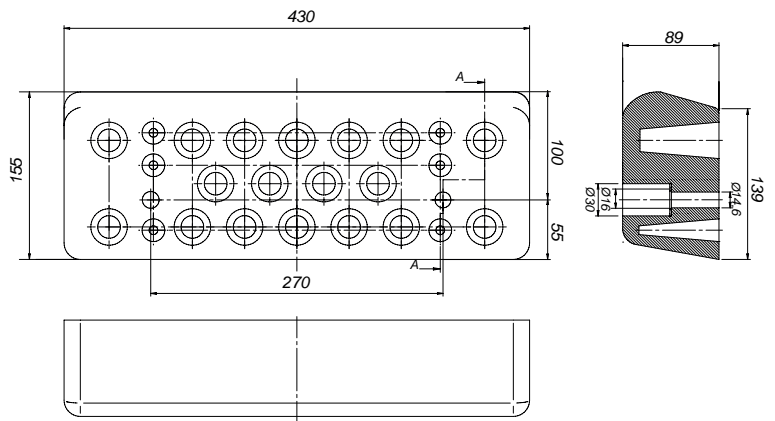



BUMPER END CAP / STOSSSTANGENENDSTÜCK / TOPE PARAGOLPES

PLYWOOD BOARDS-CHASSIS / BODENPLATTEN-FAHRGESTELLZUBEHÖR / TABLEROS-CHASSIS

Rubber Bumper Cone form 60xØ46
Gummi-Rammpuffer Kegelförmig 60xØ46
Tope Cónico Goma 60xØ46

Ref	Kg	Mat	Ø	Lot
1703184	0.08		46	2

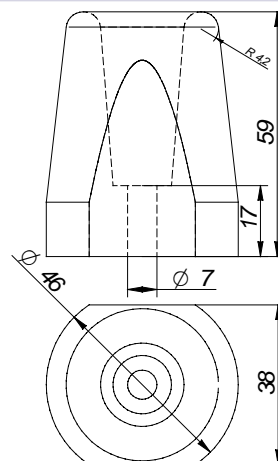
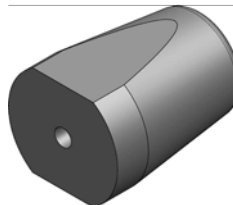
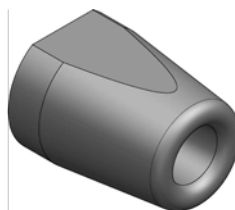

Rubber Bumper Cone form 75xØ64,5
Gummi-Rammpuffer Kegelförmig 75xØ64,5
Tope Cónico Goma 75xØ64,5

Ref	Kg	Mat	Ø	Lot
1703186	0.21		64.5	2

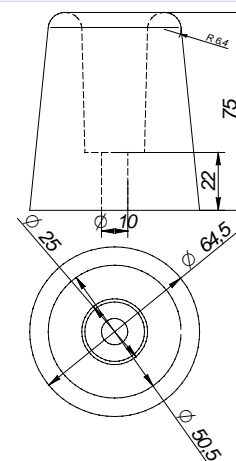
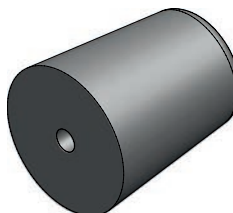
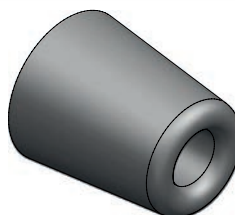

Pack 50 units Rubber Bumper Cone form 14xØ28
Pack 50 units Gummi-Rammpuffer Kegelförmig 14xØ28
Pack 50 uds. Tope Cónico Goma 14xØ28

NEW

Ref	Kg	Mat	Ø	Lot	Pack
1703183	0.65		28	1	50

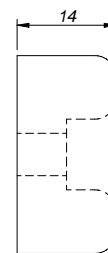
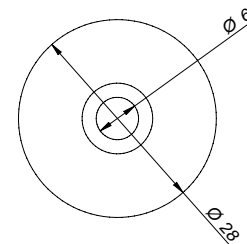
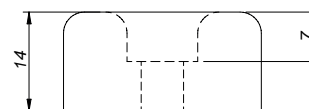
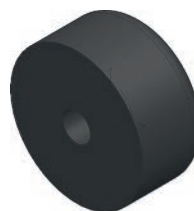

Pack 10 units Rubber Bumper Cone form 65xØ38
Pack 10 units Gummi-Rammpuffer Kegelförmig 65xØ38
Pack 10 uds. Tope Cónico Goma 65xØ38

NEW

Ref	Kg	Mat	Ø	Lot	Pack
1703189	0.66		38	1	10

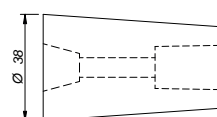
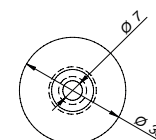
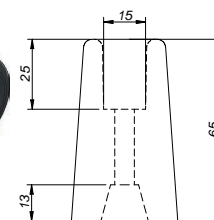

Rolling Support Simple Steel
 Rollenhalterung Einfach Stahl
 Soporte Rodillo Simple Acero

Ref	Kg	Mat	Sup/Finish Acabado	Lot
1703212	1.35	STEEL	Zn	2

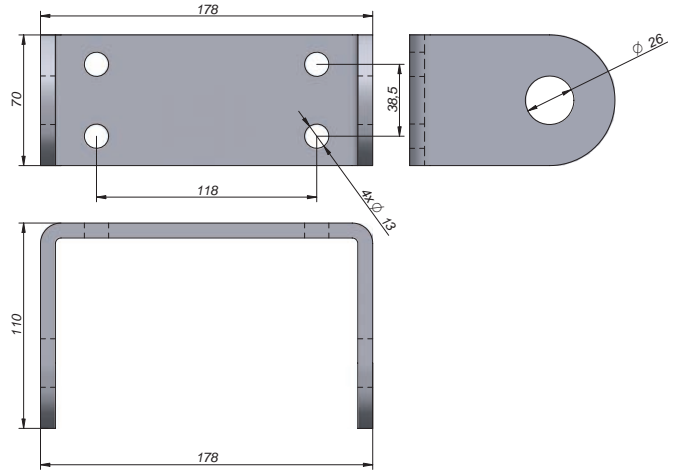
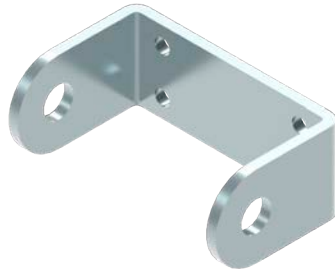

Steel Axle 200xØ25
 Achse 200xØ25 Stahl
 Eje Rodillo 200xØ25 Acero

Ref	Kg	Mat	Sup/Finish Acabado	Lot
1703214	0.78	STEEL	Zn	1

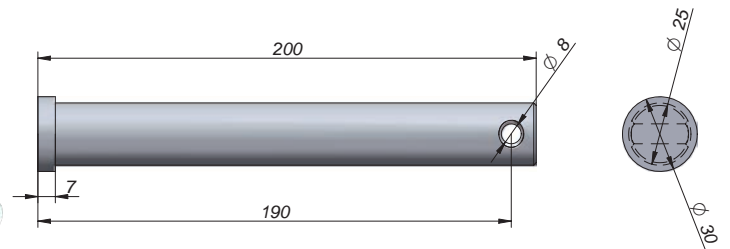
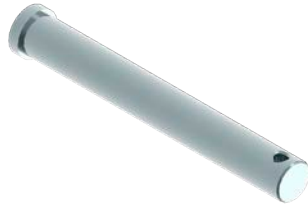

Rolling Support Double Steel
 Rollenhalterung Doppelt Stahl
 Soporte Rodillo Doble Acero

Ref	Kg	Mat	Sup/Finish Acabado	Lot
1703220	5.24	STEEL	Zn	1

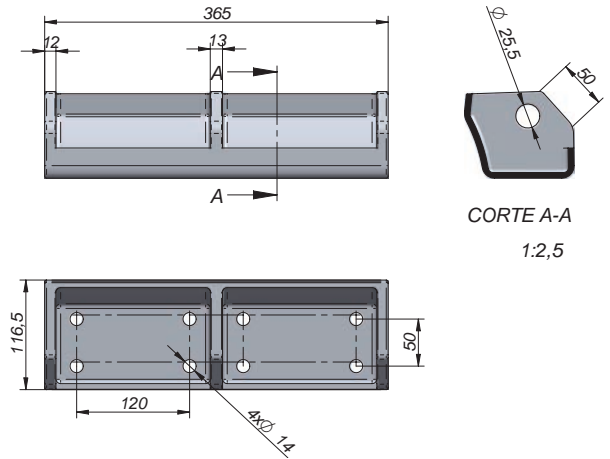

Steel Axle 388xØ25
 Achse 388xØ25 Stahl
 Eje Rodillo 388xØ25 Acero

Ref	Kg	Mat	Sup/Finish Acabado	Lot
1703222	1.51	STEEL	Zn	1

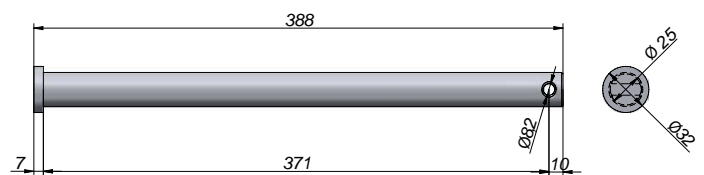
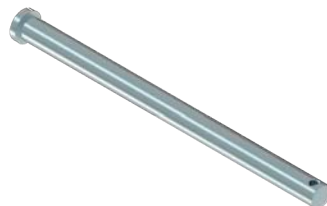



RUBBER ROLLING BUMPER / ROLLRAMMPUFFER / TOPE RODILLO

PLYWOOD BOARDS-CHASSIS / BODENPLATTEN-FAHRGESTELLZUBEHÖR / TABLEROS-CHASIS

Rolling Bumper Steel Pin
Stahl-Splint
Pasador Rodillo Acero

Ref	Kg	Mat	Lot
1703216	0.02	STEEL	4

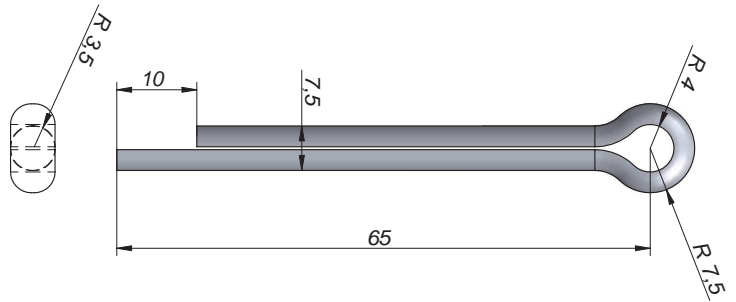

Rolling Bumper 80xØ100 Rubber with axle Bushing
Ersatzrolle 80xØ100 Gummi mit Buchse
Rodillo 80xØ100 Goma c/Casquillo interior

Ref	Kg	Mat	Lot
1703208	0.85		2

with metallic axle bushing
Con casquillo interior metálico

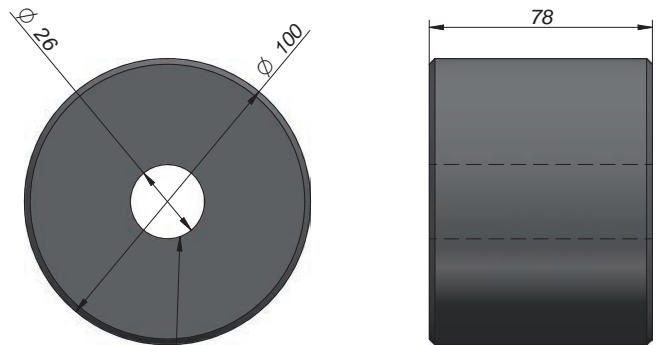

Rolling Bumper 130xØ100 Rubber with axle Bushing
Ersatzrolle 130xØ100 Gummi mit Buchse
Rodillo 130xØ100 Goma c/Casquillo interior

Ref	Kg	Mat	Lot
1703206	1.48		1

with metallic axle bushing
Con casquillo interior metálico

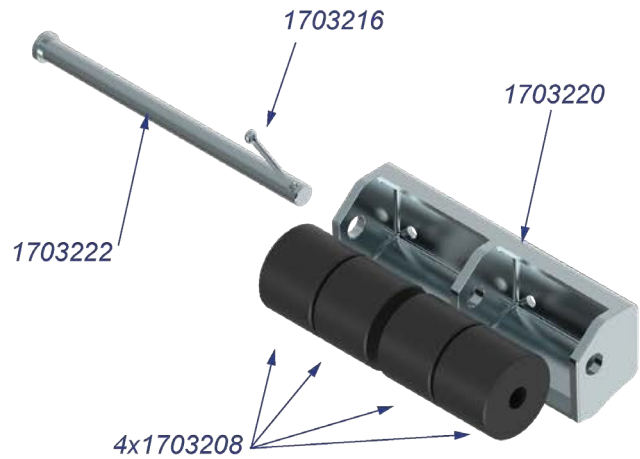
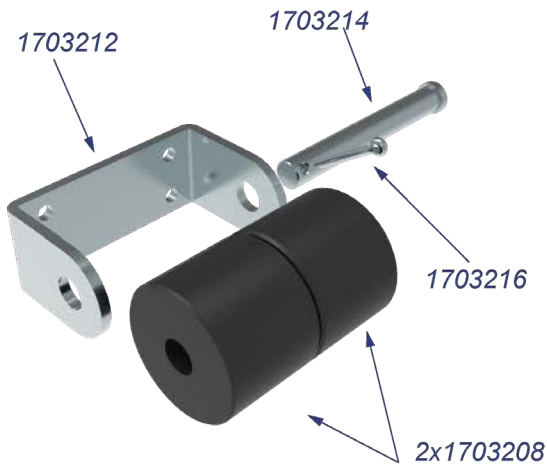
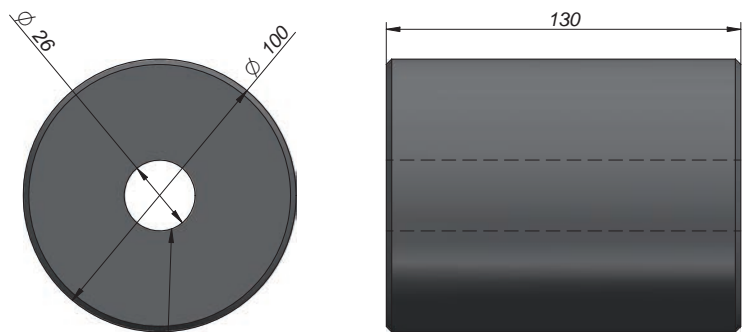

Horizontal Rear 2 Rolling Bumper
 Rollrammpuffer Horizontal, 2 Rollen
 Tope Trasero 2 Rodillos Horizontal

Ref	Kg	Mat	Sup/Finish Acabado	Pos	Lot
1703230	4	STEEL	Galv	↔	1

Bumper Rubber
 Rodillo de Goma

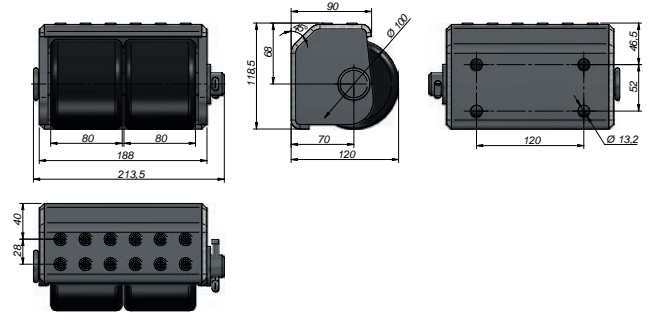

Horizontal Rear 4 Rolling Bumper
 Rollrammpuffer Horizontal, 4 Rollen
 Tope Trasero 4 Rodillos Horizontal

Ref	Kg	Mat	Sup/Finish Acabado	Pos	Lot
1703232	10	STEEL	Galv	↔	1

Bumper Rubber
 Rodillo de Goma

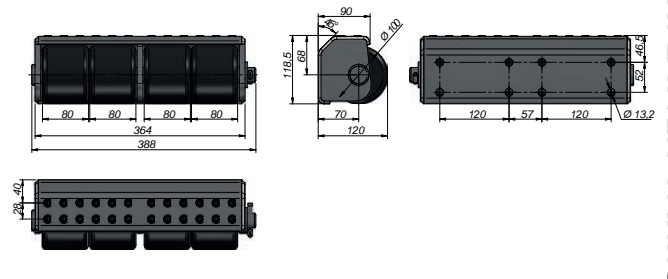

Vertical Rear 3 Rolling Bumper
 Rollrammpuffer Vertikal, 3 Rollen
 Tope Trasero 3 Rodillos Vertikal

Ref	Kg	Mat	Sup/Finish Acabado	Pos	Lot
1703234	13	STEEL	Galv	↕	1

Bumper Rubber
 Rodillo de Goma

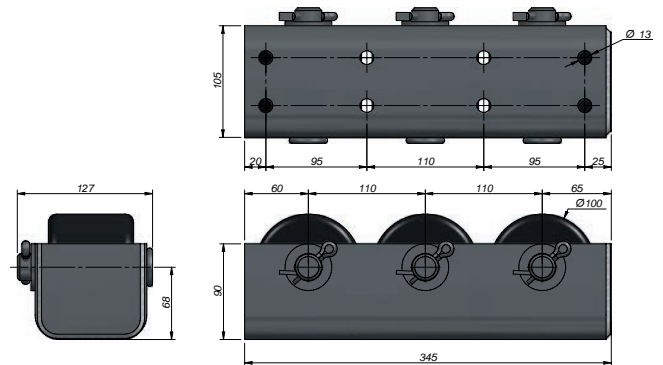

Rubber Bumper 155x67x77 2 Blocks
 Gummi-Rammpuffer 155x67x77 Doppelblock
 Tope Goma 2 Cuerpos 155x67x77

Ref	Kg	Mat	Lot
1703110	0.96		2

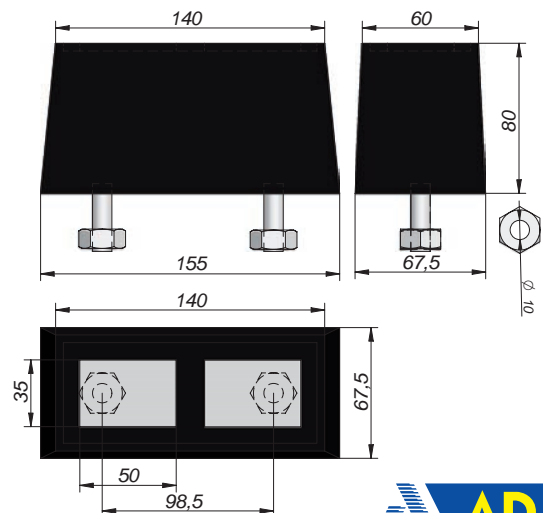



METAL BUMPER / METALLPUFFER / TOPES METÁLICOS

PLYWOOD BOARDS-CHASSIS / BODENPLATTEN-FAHRGESTELLZUBEHÖR / TABLEROS-CHASIS

Rear Bumper ADAROLL
Feder-Rammpuffer ADAROLL
Tope Paragolpes Trasero ADAROLL

NEW

Ref	Kg	Mat	Sup/Finish Acabado	Pos	Lot
1703256	6.9	STEEL	Galv		2

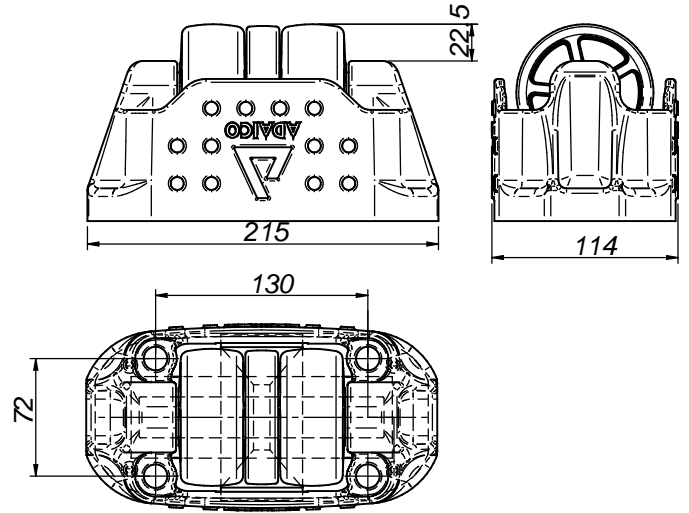

Rear Bumper 180x80x105 w/Shock Absorber
Feder-Rammpuffer 180x80x105 m/Dämpfer
Tope Paragolpes Trasero 180x80x105 c/Amortiguador

Ref	Kg	Mat	Pos	Lot
1703252	3	STEEL		2

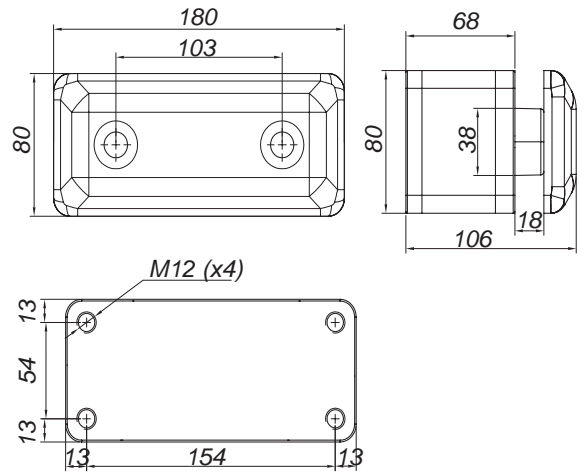

Rear Bumper 200x100x120 w/Shock Absorber
Feder-Rammpuffer 200x100x120 m/Dämpfer
Tope Paragolpes Trasero 200x100x120 c/Amortiguador

Ref	Kg	Mat	Pos	Lot
1703254	4.3	STEEL		2

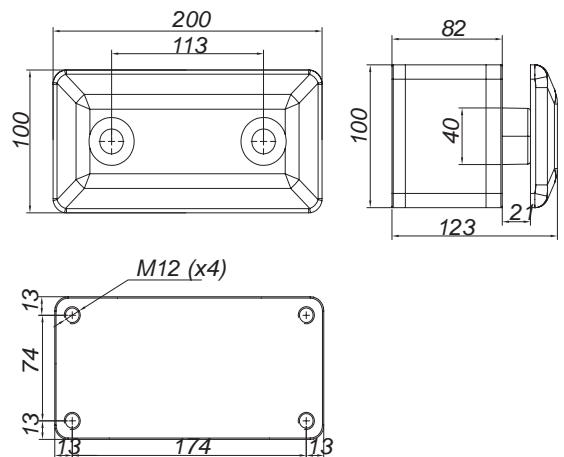

Transporte Frigorífico

Temperature Controlled Transport

Transport Frigorifique

Kühltransport

Transporte Frigorifico

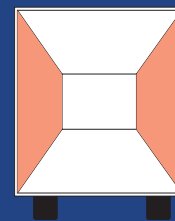

Poliéster

Polyester Laminates

Polyester

Polyester

Poliester



pag. 186-187

Transporte de Carne

Meat Transport

Transport de Viande

Fleischtransport

Transporte de Carnes



pag. 188-190

Pared Elevadora

Rollshutter

Cloison Mobile

Trennwand

Parede Elevatória



pag. 191-192

Ventiladores Techo

Roof Ventilator

Ventilateur De Toit

Deckenventilator

Ventilador Teto



pag. 193-196



POLYESTER LAMINATES / POLYESTER / POLIÉSTER

TEMPERATURE CONTROLLED TRANSPORT / KÜHLFAHRZEUG-ZUBEHÖR / TRANSPORTE FRIGORÍFICO

Mechanical Sanded Polyester Roll e= 2 mm.
Polyester Roll Mechanische Bearbeitung e= 2 mm.
Rollo de Poliéster Mecanizado Mecánico e= 2mm.

Ref	Kg	Mat	Sup/Finish Acabado	A	B	Thickn. Espesor	Lot
0401016	162	GRP	MMec	2000	30000	2±0,2	1
0401014	178.2	GRP	MMec	2200	30000	2±0,2	1
0401012	195	GRP	MMec	2400	30000	2±0,2	1
0401010	202.5	GRP	MMec	2500	30000	2±0,2	1
0401008	210	GRP	MMec	2600	30000	2±0,2	1
0401006	226.8	GRP	MMec	2800	30000	2±0,2	1
0401004	243	GRP	MMec	3000	30000	2±0,2	1

Application: Polyurethane Adhesive or Resin | RAL 9003 with Film
Aplicación: Adhesivo de Poliuretano o Resina | RAL 9003 c/Film
Conformidad materiales/articulos destinados a entrar en contacto con alimentos.
Legislación: (CE) 1935/04; (CE) 2023/06; (CE) 10/11; D.M. 21/03/1973

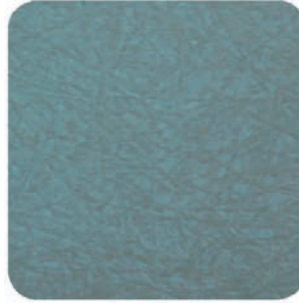

Adhesivo / Adhesive



Resina / Resin

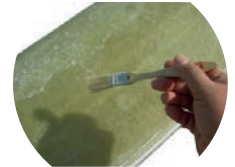

Mechanical Sanded Polyester Roll e= 1,5 mm.
Polyester Roll Mechanische Bearbeitung e= 1,5 mm.
Rollo de Poliéster Mecanizado Mecánico e= 1,5 mm.

Ref	Kg	Mat	Sup/Finish Acabado	A	B	Thickn. Espesor	Lot
0401027	111	GRP	MMec	2000	30000	1,5±0,2	1
0401026	138.6	GRP	MMec	2200	30000	1,5±0,2	1
0401022	157.5	GRP	MMec	2500	30000	1,5±0,2	1
0401020	270	GRP	MMec	3000	30000	1,5±0,2	1

Application: Polyurethane Adhesive or Resin | RAL 9003 with Film
Aplicación: Adhesivo de Poliuretano o Resina | RAL 9003 c/Film
Conformidad materiales/articulos destinados a entrar en contacto con alimentos.
Legislación: (CE) 1935/04; (CE) 2023/06; (CE) 10/11; D.M. 21/03/1973

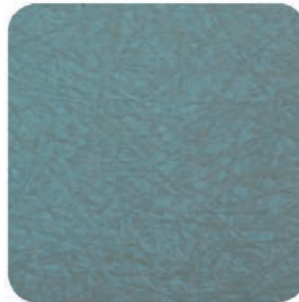

Adhesivo / Adhesive



Resina / Resin

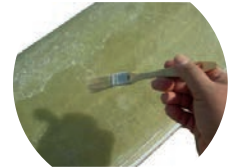



Sanded Polyester Roll
Polyester Rolle Bearbeitet
Rollo de Poliéster Mecanizado

Ref	Kg	Mat	Sup/Finish Acabado	A	B	Thickn. Espesor	Lot
0401170	180	GRP	MEC	2000	30000	2±0,2	1
0401165	198	GRP	MEC	2200	30000	2±0,2	1
0401163	234	GRP	MEC	2400	30000	2±0,2	1
0401160	225	GRP	MEC	2500	30000	2±0,2	1
0401158	234	GRP	MEC	2600	30000	2±0,2	1
0401155	252	GRP	MEC	2800	30000	2±0,2	1
0401150	270	GRP	MEC	3000	30000	2±0,2	1
0401221	202	GRP	MEC	2200	30000	2,5±0,2	1
0401229	234.72	GRP	MEC	2400	30000	2,5±0,2	1
0401232	254.28	GRP	MEC	2600	30000	2,5±0,2	1
0401231	273.84	GRP	MEC	2800	30000	2,5±0,2	1
0401233	293.4	GRP	MEC	3000	30000	2,5±0,2	1
0401226	342	GRP	MEC	1800	60000	3±0,2	1
0401235	238	GRP	MEC	2200	30000	3±0,2	1
0401238	476	GRP	MEC	2200	60000	3±0,2	1
0401236	260	GRP	MEC	2400	30000	3±0,2	1
0401240	520	GRP	MEC	2400	60000	3±0,2	1
0401237	285	GRP	MEC	2600	30000	3±0,2	1
0401244	570	GRP	MEC	2600	60000	3±0,2	1
0401239	306.5	GRP	MEC	2800	30000	3±0,2	1
0401245	613	GRP	MEC	2800	60000	3±0,2	1



Adhesivo / Adhesive



Application: Only with Polyurethane Adhesive | RAL 9003 c / Film
Aplicación: Sólo con Adhesivo de Poliuretano | RAL 9003 c/Film
Conformidad materiales/artículos destinados a entrar en contacto con alimentos. Legislación: (CE) 1935/04; (CE) 2023/06; (CE) 10/11; D.M. 21/03/1973

Sheet metal shears up to 1.6 mm
Blechscherer bis 1.6 mm
Cizalla para chapa hasta 1.6 mm

NEW

Ref	Kg	Article	Lot
0480070	3.01	Including: knife set 1 pair of keys 1 chip deflector Incluye: juego de cuchillas 1 pareja de llaves 1 deflector de virutas	1

Handy shears suitable for curves to cut and edge thin sheets
Cizalla manejable y apta en curvas para cortar y cantar chapas de poco grosor

ESPECIAL CORTE POLIÉSTER
SPECIAL FOR CUTTING POLYESTER
POUR COUPER LA PEAU POLYESTER



TEMPERATURE CONTROLLED TRANSPORT / KÜHLFAHRZEUG-ZUBEHÖR / TRANSPORTE FRIGORÍFICO



TRANSPORTE DE CARNE
MEAT TRANSPORT

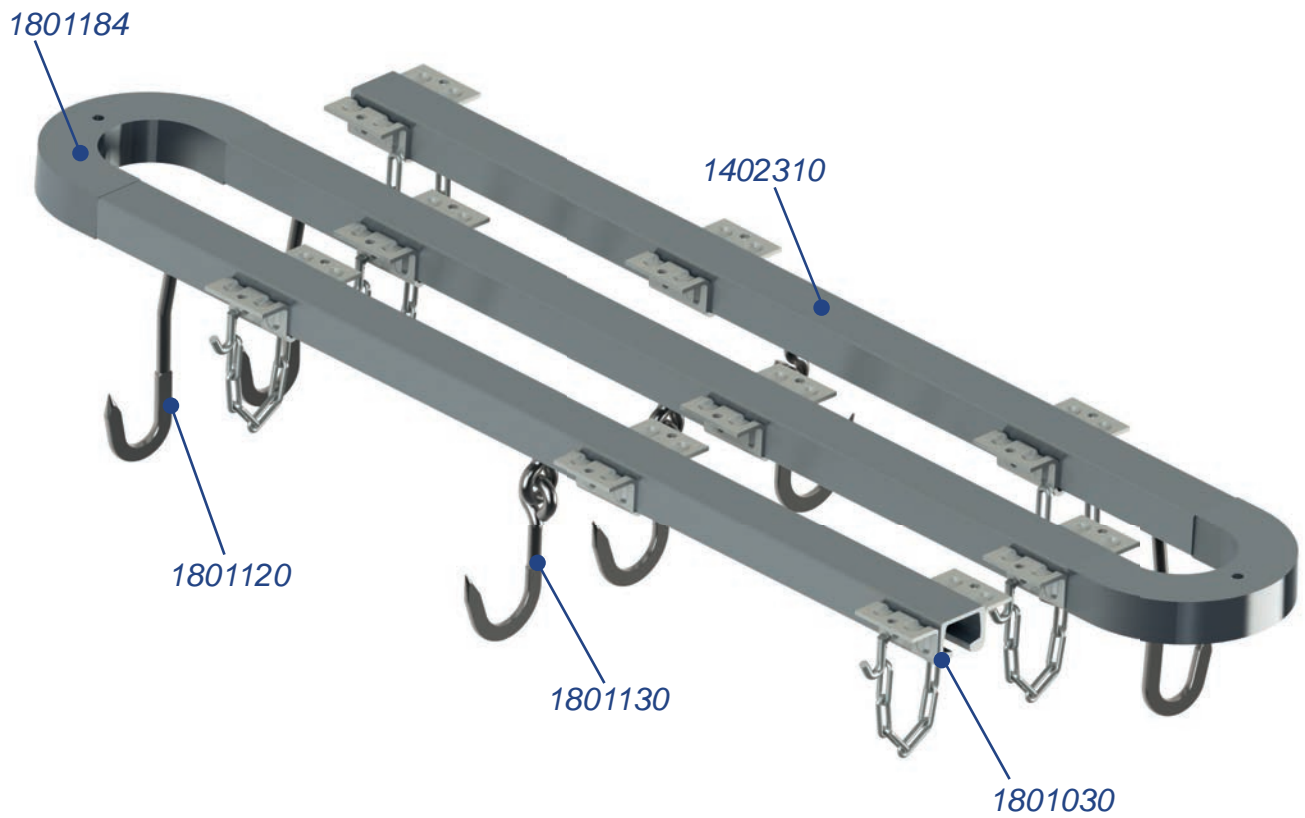

MEAT TRANSPORT / LAUFSCHIENE FLEISCHTRANSPORT / TRANSPORTE DE CARNE

Bar Profile Meat Hook Aluminium
Laufschiene Aluminium f. Fleischhaken Eloxiert
Barra Perfil Gancho Carne Aluminio

Ref	Kg	Mat	Sup/Finish Acabado	A	Thickn. Espesor	Lot
1402312	7.28		Anod	3 m.	4	1

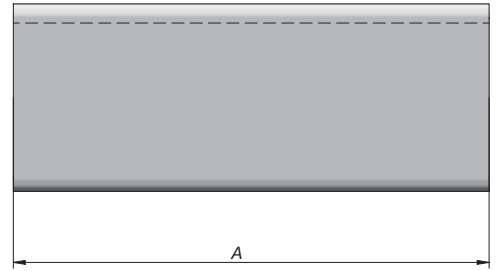
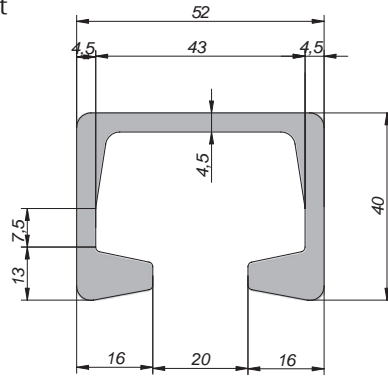

Track Support Kit Meat Hook Stainless Steel with Chain
Halte für Fleischhaken-Laufschiene, Edelstahl, Mit Kette
Kit Soporte Carril Gancho Carne Inox c/Cadena

Ref	Kg	Mat	Sup/Finish Acabado	Lot
1801030	0.42	INOX		10

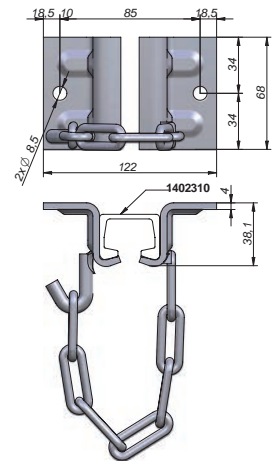

Meat Hook Fix Stainless Steel
Fleischhaken Fest, Edelstahl
Gancho Carne Fijo Inox

Ref	Kg	Mat	Sup/Finish Acabado	Lot
1801120	0.27	INOX		10

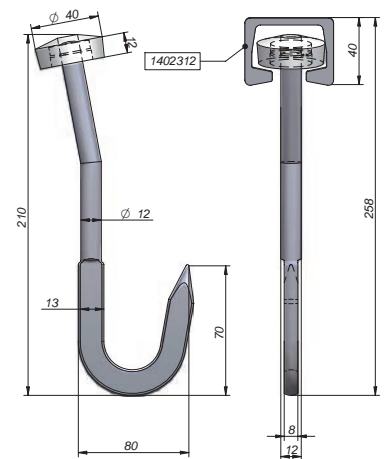
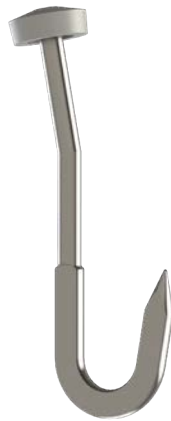

Meat Hook Fix
Fleischhaken Fest
Gancho Carne Fijo

Ref	Kg	Mat	Lot
1801122	0.23	INOX	10

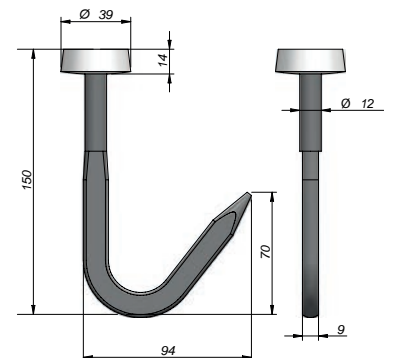

TEMPERATURE CONTROLLED TRANSPORT / KÜHLFAHRZEUG-ZUBEHÖR / TRANSPORTE FRIGORÍFICO



MEAT TRANSPORT / LAUFSCHIENE FLEISCHTRANSPORT / TRANSPORTE DE CARNE

TEMPERATURE CONTROLLED TRANSPORT / KÜHLFAHRZEUG-ZUBEHÖR / TRANSPORTE FRIGORÍFICO

Meat Hook Articulated Stainless Steel
Fleischhaken schwenkbar, Edelstahl
Gancho Carne Articulado Inox

Ref	Kg	Mat	Sup/Finish Acabado	Lot
1801130	0.42	INOX		10

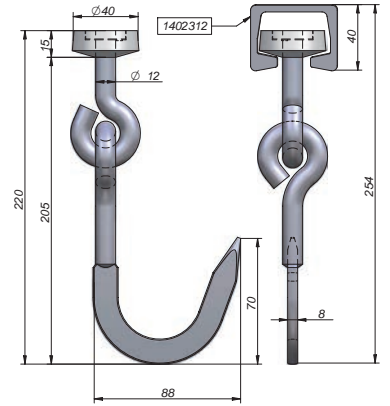

Hook Stainless Steel DIN 5047
Haken Edelstahl DIN 5047
Gancho Inox DIN 5047

Ref	Kg	Mat	Lot
1801132	1.35	INOX	1

Stainless steel hook; Galvanized steel anchoring
Gancho acero inoxidable; Anclaje de acero galvanizado/galvanisé

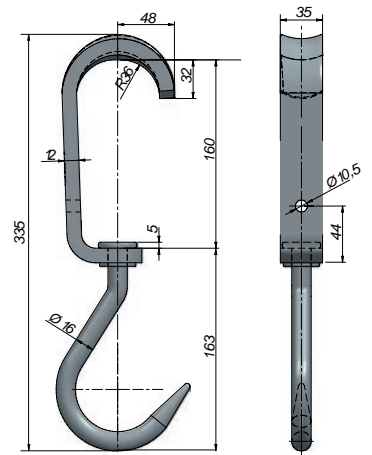

Washer Meat Hook Nylon
Ersatzlaufscheibe für Fleisch Haken Nylon
Arandela Gancho Carne Nylon

Ref	Kg	Mat	Lot
1801300	0.02	Ny	10

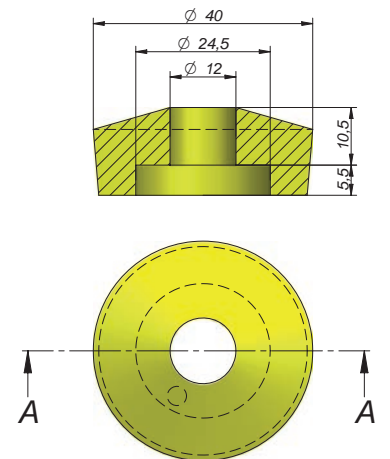
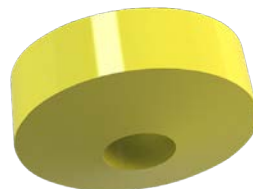

Rail Curve Meat Hook Aluminium
Kurvenschiene für Fleischhaken Aluminium
Curva Carril Gancho Carne Aluminio

Ref	Kg	Mat	Lot
1801184	0.6		1

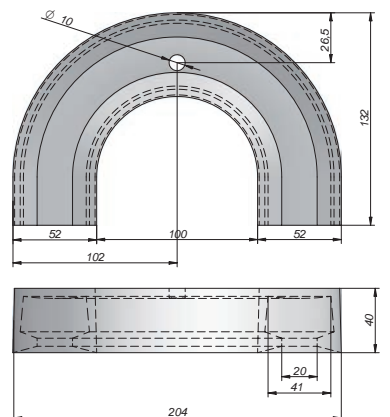
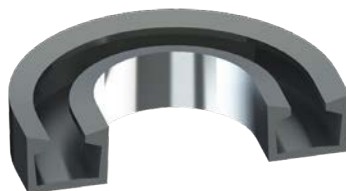

MECHANIC ANCHORING SYSTEM ROLLSHUTTER / LAUFSCHIENE ROLLTOR / SISTEMA ANCLAJE MANUAL PARED ELEVADORA



TEMPERATURE CONTROLLED TRANSPORT / KÜHLFAHRZEUG-ZUBEHÖR / TRANSPORTE FRIGORÍFICO

Parts Partes	Ref. Ref.	Quantity by Rollshutter Cantidad por Pared Móvil	
A	2201160	1 Kit = 2 uds.	
B	2201152 (Kg. 150)	4	
	2201159 (Kg. 200)		
	2201158 (Kg. 250)		
C	1402308 (3,5 m.)	According to measure <i>Según Medida</i>	
D	2201170 (3,5 m.)	According to measure <i>Según Medida</i>	
E	2201172	1	
F	2201178	1	



2 Set Lifter Arms in Stainless Steel
2 Set Liftarm Edelstahl
Kit 2 uds. Brazo Elevador

Ref	Kg	Mat	Lot
2201160	13.01	INOX	1

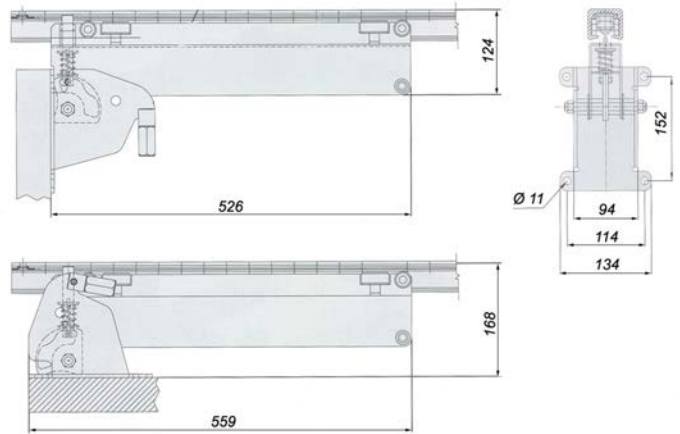

Gas Spring
Gasfeder
Amortiguador

Ref	Kg	Mat	Strength Fuerza	Lot
2201152	0.63	INOX	150 kg	1
2201159	0.63	STEEL	200 kg	1
2201158	0.67	STEEL	250 kg	1

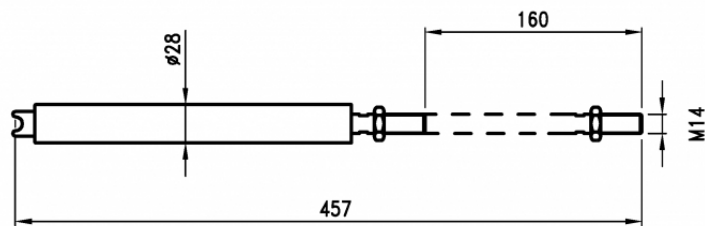

Bar Profile Rollshutter Aluminium Anodized
Laufschiene Aluminium Eloxiert
Perfil Pared Móvil Aluminio Anodizado

Ref	Kg	Mat	Sup/Finish Acabado	A	Lot
1402308	8.12	A	Anod	3,5 m.	1

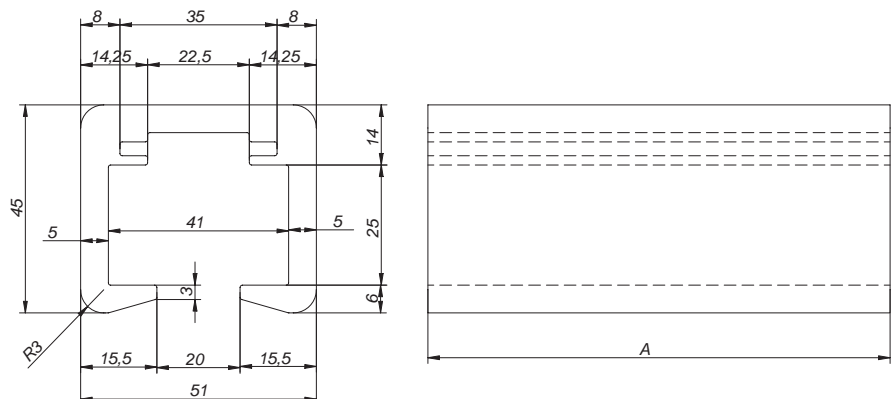



MECHANIC ANCHORING SYSTEM ROLLSHUTTER / LAUFSCHIENE ROLLTOR / SISTEMA ANCLAJE MANUAL PARED ELEVADORA

TEMPERATURE CONTROLLED TRANSPORT / KÜHLFAHRZEUG-ZUBEHÖR / TRANSPORTE FRIGORÍFICO

Rack for Mobile Inner Wall Track
Blockierleiste für Bewegliches Trennwandsystem
Cremallera Guía

Ref	Kg	Mat	A	Lot
2201170	1.78	INOX	3,5 m.	1

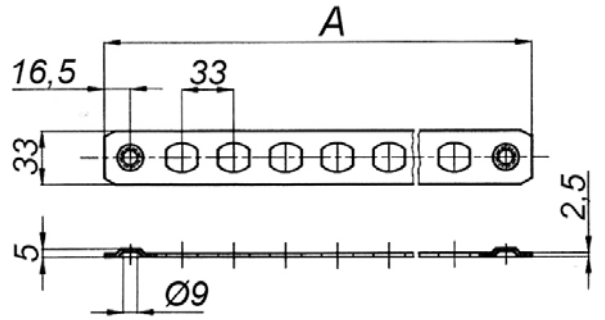

Runner Clamp
Laufwagen mit Blockierung
Tirador

Ref	Kg	Mat	Lot
2201172	1.88	INOX	1

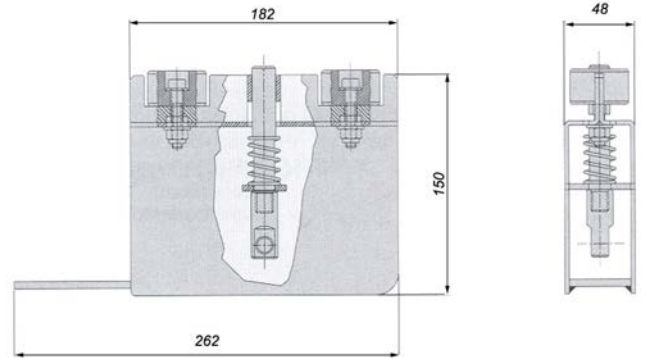

Holder
Halter
Resbalón

Ref	Kg	Mat	Lot
2201178	0.05	INOX	1

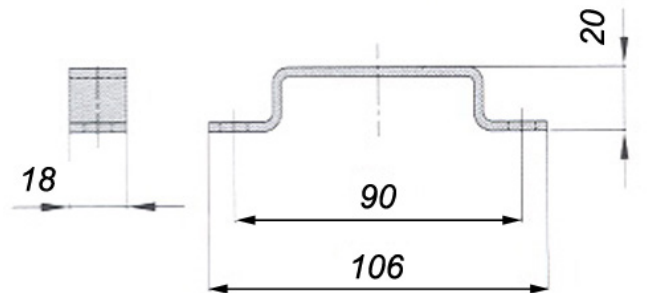

Gas Spring
Gasfeder
Amortiguador a Gas

Ref	Kg	A	B	C	D	Ø	Thickn. Espesor	Strength Fuerza	Lot
1683004	0.3	296-491	195	18	6.1	8	5	450 N	1
1683010	0.3	353,5-603,5	250	18	8.1	8	5	600 N	1
1683006	0.43	290-500	210	22	8.1	10	5	600 N	1
1683012	0.5	352-600	248	22	8.1	10	5	800 N	1
1683014	0.5	352-600	248	22	8.1	10	5	1.000 N	1
1683018	0.51	402-700	298	22	8.1	10	5	800 N	1
1683022	0.65	452-800	348	22	8.1	10	5	1.000 N	1
1683024	0.97	452-800	348	27	8.1	14	5	1.500 N	1
1683026	0.5	353,5-603,5	250	27	8.1	10	5	800 N	1

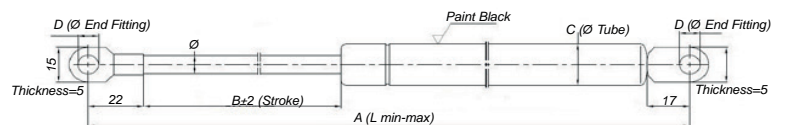

With threaded heads
Con cabezas roscadas

VENTILADORES DE TECHO ROOF VENTILATOR



TEMPERATURE CONTROLLED TRANSPORT / KÜHLFAHRZEUG-ZUBEHÖR / TRANSPORTE FRIGORÍFICO

Air extraction rate
Tasa de Extracción de aire

*Ref. 2569024/26 - 830 m³/h

Ref.	2569020/22	Ref.	2569030/32	2569034
Km/h	m3/h	Km/h	m3/h	m3/h
16	13,8	20	15	55
32	32,4	40	37	95
48	50,4	60	57	180
64	69,6	80	72	238
80	88,8	100	90	280
96	107,4	110	130	320
112	127,8			



Specifications
Características

Ref.	Ø Aguj. Trou	Ø Ext.	h (mm.)	😊	Works with engine off Funciona con motor apagado	Internal grille (separate) Rejilla interna (aparte)	V	W	switch	ECE R10	Dim. (mm.)	Color
2569030/32	80	230	56	✓	✓						230x230x56	●
2569034	100	235	120	✓	✓	Ref. 2569103					235x235x120	○
2569020/22	96	226	102								226x226x102	●
2569024/26	230-245		64			Ref. 2569101/02	12	80	Ref. 2569100	✓	385x312x64	●

Rotary Roof Ventilator SLIM Ø230xh56
Rotierend Dachventilator SLIM Ø230xh56
Aireador Techo Giratorio SLIM Ø230xh56

Ref	Kg	Col	Ø	Article	Lot
2569030	0.67	○	Ø80	Øexterior: 230 mm. Øexterior: 230 mm.	1
2569032	0.67	●	Ø80	Øexterior: 230 mm. Øexterior: 230 mm.	1

Ultra quiet (works even when stopped) | Air Extraction: 20Km/h: 15m3/h | 40Km/h: 37m3/h | 60Km/h: 57m3/h | 80Km/h: 72m3/h | 100Km/h: 90m3/h | 110Km/h: 130

Ultra silencioso (incluso en stop) | Extracción aire: 20Km/h: 15m3/h | 40Km/h: 37m3/h | 60Km/h: 57m3/h | 80Km/h: 72m3/h | 100Km/h: 90m3/h | 110Km/h: 130

NEW





ROOF VENTILATOR / DECKENVENTILATOR / VENTILADORES TECHO

TEMPERATURE CONTROLLED TRANSPORT / KÜHLFAHRZEUG-ZUBEHÖR / TRANSPORT FRIGORIFICO

Rotary Roof Ventilator Ø235xh120
Rotierend Dachventilator Ø235xh120
Aireador Techo Giratorio Ø235xh120

NEW

Ref	Kg	Col	Ø	Article	Lot
2569034	1.7	○	Ø100	Øexterior: 230 mm. Øexterior: 230 mm.	1

Ultra quiet (works even when stopped)|Air Extraction: 20Km/h: 55m3/h | 40Km/h: 95m3/h | 60Km/h: 180m3/h | 80Km/h: 238m3/h | 100Km/h: 280m3/h | 110Km/h: 320
Ultra silencioso (incluso en stop)|Extracción aire: 20Km/h: 55m3/h | 40Km/h: 95m3/h | 60Km/h: 180m3/h | 80Km/h: 238m3/h | 100Km/h: 280m3/h | 110Km/h: 320



Inner Grid for Roof Electric Aerator 2569034
Innere Gitter für Elektrisch Dachventilator 2569034
Rejilla interior para Aireador Techo 2569034

NEW

Ref	Kg	Mat	Col	Lot
2569103	1.7	🔪	●	1



INSTRUCCIONES DE INSTALACIÓN
INSTALLATION INSTRUCTIONS

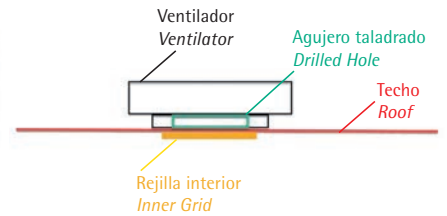

Roof Ventilator F2000 Black
Dachventilator F2000 Schwarz
Ventilador Techo F2000 Negro

Ref	Kg	Col	Lot
2569020	0.9	●	1

Can be fitted to vehicles with ribbed roofs provided that the gap between each rib is at least 145mm / 5.75".
Puede montarse en vehículos con techo acanalado siempre y cuando el espacio entre canales sea de por lo menos 145mm / 5.75".

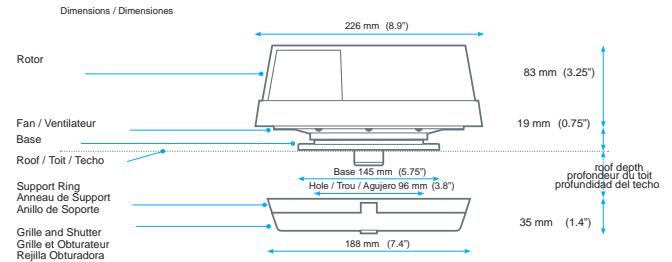

Roof Ventilator F2000 White
Dachventilator F2000 Weiss
Ventilador Techo F2000 Blanco

Ref	Kg	Col	Lot
2569022	0.9	○	1

Can be fitted to vehicles with ribbed roofs provided that the gap between each rib is at least 145mm / 5.75".
Puede montarse en vehículos con techo acanalado siempre y cuando el espacio entre canales sea de por lo menos 145mm / 5.75".

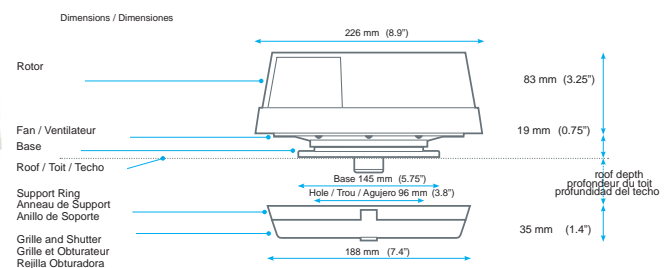

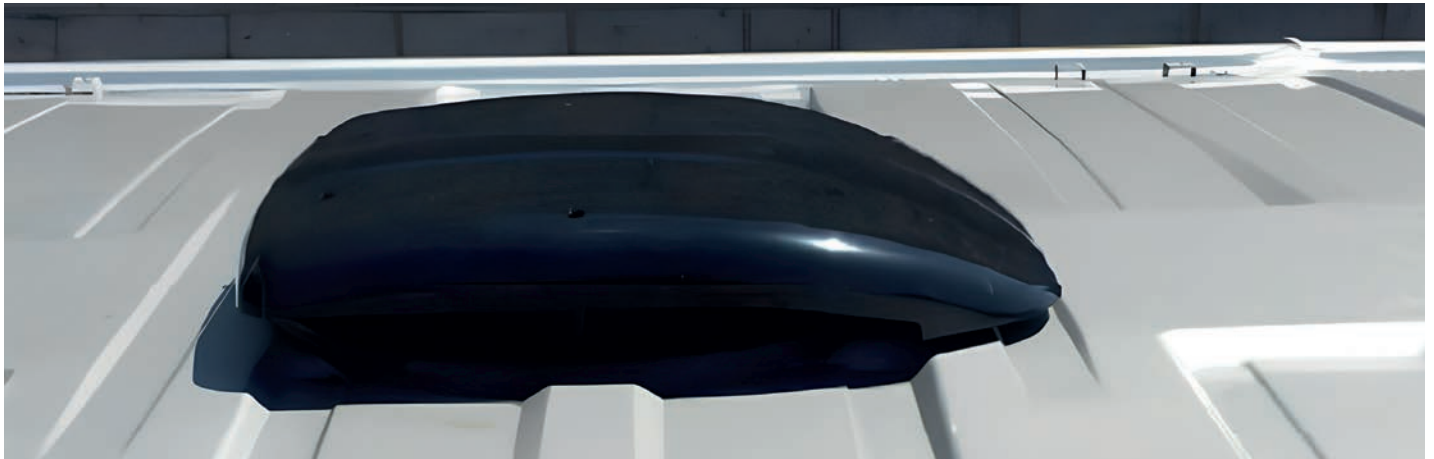

Electric Roof Ventilator 12V 80W
 Elektrisch Dachventilator 12V 80W
 Aireador Techo Eléctrico 12V 80W

NEW

Ref	Kg	Col	W	Emark	Lot
2569024	1.7		12v		1
2569026	1.7		12v		1

Functions: Extraction and/or aeration | Air extraction: 850 m3/h
 Funciones: Extracción y/o aireación | Extracción de aire: 850m3/h
 ECE-R10

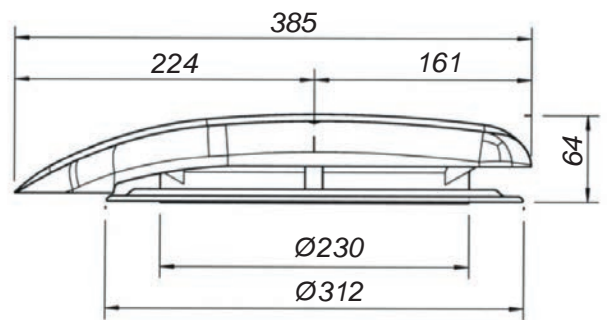

Inner Grid for Roof Aerator 2596024/26
 Inneres Gitter für Elektrisch Dachventilator 2596024/26
 Rejilla interior para Aireador 2569024/26

NEW

Ref	Kg	Col	Lot
2569101	0.15		1
2569102	0.15		1

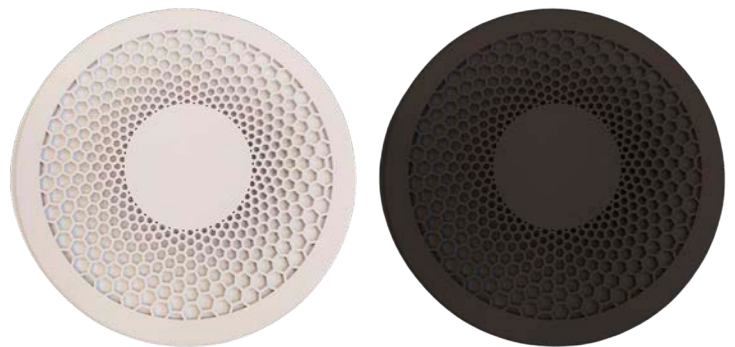

Switch for Roof Electric Aerator 2596024/26
 Schalter für Elektrisch Dachventilator 2596024/26
 Interruptor Inversor p/Aireador Eléctrico 2569024/26

NEW

Ref	Kg	Lot
2569100	0.39	1





ROOF VENTILATOR / DECKENVENTILATOR / VENTILADORES TECHO

TEMPERATURE CONTROLLED TRANSPORT / KÜHLFAHRZEUG-ZUBEHÖR / TRASPORTE FRIGORIFICO



Accesorios de Lonas
Curtain Accesories
Accessoires Cabine
Planenzubehör
Acessório de Lonas

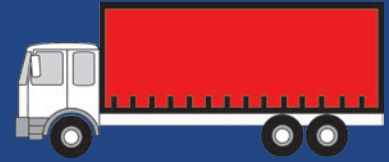

Ruletas

Rollers

Roulette

Rollen

Rodizios



pag. 198-211

Tensores

Tensioners

Tendeurs

Spanngetriebe

Tensores



pag. 212-222

Ganchos y Puentes

Curtain Hooks

Crochets

Planenhaken

Ganchos e Cintas

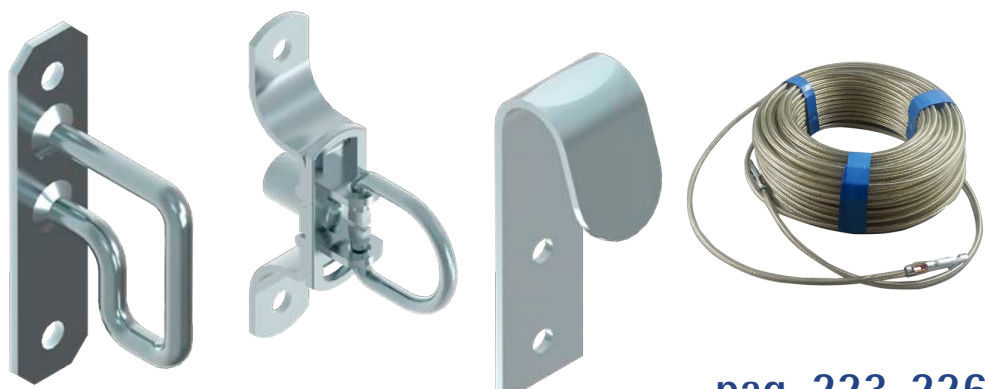

pag. 223-226

Hebillas

Buckles

Bas De Rideaux

Planschnallen

Cintas



pag. 227-230



ROLLERS / ROLLEN / RULETAS

CURTAIN ACCESSORIES / PLANEN-ZUBEHÖR / ACCESORIOS DE LONAS

Roller Simple Ø35x30 Beveled Edge Rol. Nylon
Laufrolle Einfach Ø35x30 Rol. Nylon
Ruleta Simple Ø35x30 Biselada Rod. Nylon

Ref	Kg	Mat	Lot
0801007	0.23	STEEL	10

Nylon Roller
Rodamiento Nylon

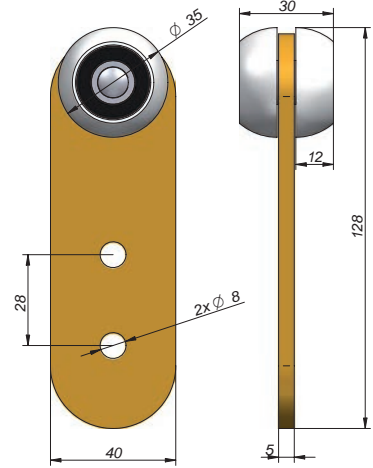

Wheel Ø35x12 Nylon Beveled Edge
Roller Ø35x12 Nylon
Rueda Ø35x12 Nylon Biselada

NEW

Ref	Kg	Mat	Col	Pack
0801302	0.23	Ny	○	10

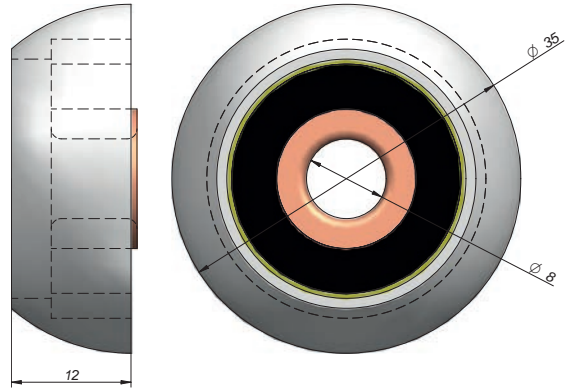

Roller Simple Ø35x30 Beveled Edge Drilled Rol. Nylon
Laufrolle Einfach Ø35x30 seitlich versetzt gebohrt Rol. Nylon
Ruleta Simple Ø35x30 Biselada Taladrada Rod. Nylon

Ref	Kg	Mat	Lot
0801121	0.24	STEEL	100

Nylon Roller
Rodamiento Nylon

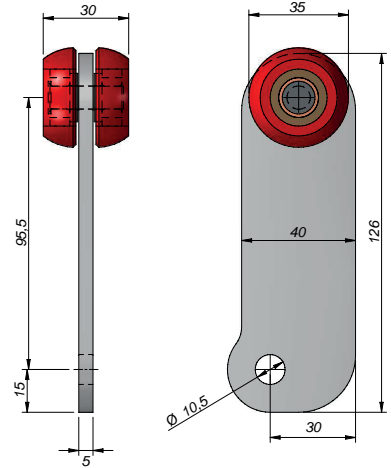
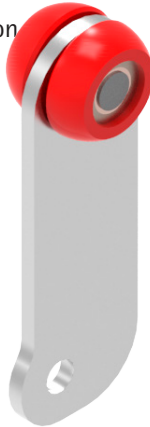

Roller Double Ø35x30 Beveled Edge Nylon Rol.
Laufrolle Einfach Ø35x30 Nylon Kugellager Anfassen
Ruleta Doble Ø35x30 Rod. Biselado

NEW

Ref	Kg	Mat	Sup/Finish Acabado	Lot	Pack
0801126	0.22	STEEL	Zn	1	10

Beveled Edge Roller
Rodamiento Biselado

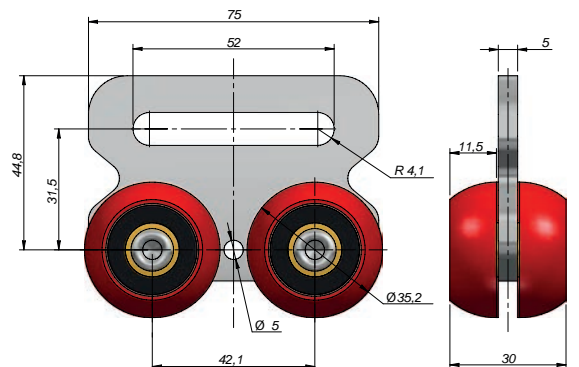

Roller Simple Ø36x30 Rol. Nylon
 Laufrolle Einfach Ø36x30 Rol. Nylon
 Ruleta Ø36x30 Rod. Nylon

Ref	Kg	Mat	Lot
0801012	0.13	STEEL	4

Nylon Roller
 Rodamiento Nylon

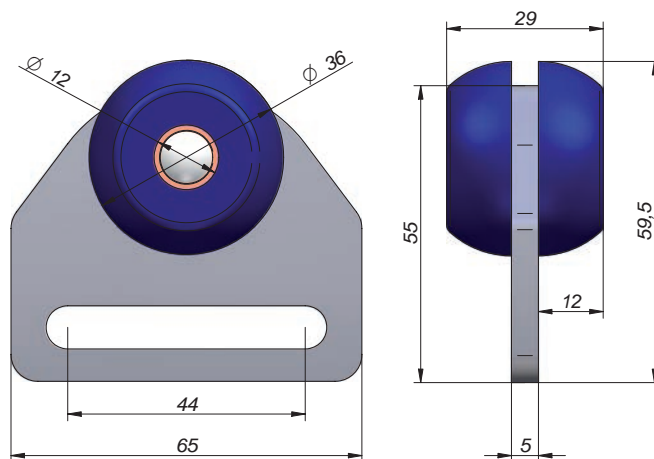
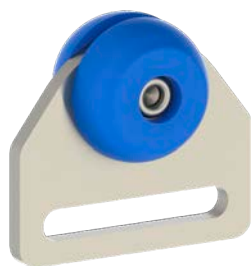

Roller Simple Ø36x30 Rol. Nylon
 Laufrolle Einfach Ø36x30 Rol. Nylon
 Ruleta Simple Ø36x30 Rod. Nylon

Ref	Kg	Mat	Lot
0801016	0.15	STEEL	10

Nylon Roller
 Rodamiento Nylon

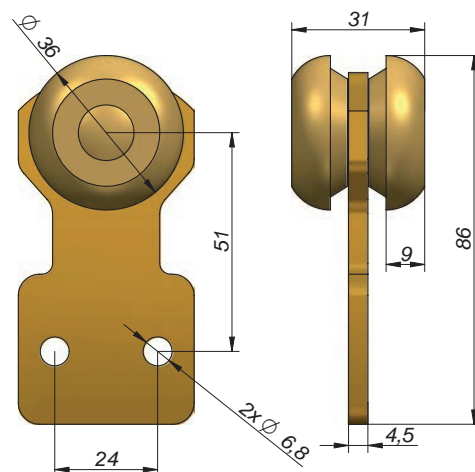

Roller Double Ø31x27 Rol. Nylon
 Laufrolle Doppelt Ø31x27 Rol. Nylon
 Ruleta Doble Ø31x27 Rod. Nylon

Ref	Kg	Mat	Lot
0801050	0.14	STEEL	1

Nylon Roller
 Rodamiento Nylon

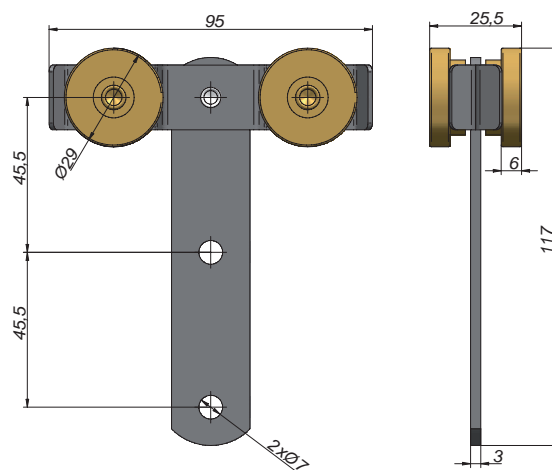

Roller Double Ø28x24 Rol. Nylon
 Laufrolle Doppelt Ø28x24 Rol. Nylon
 Ruleta Doble Ø28x24 Rod. Nylon

Ref	Kg	Mat	Sup/Finish Acabado	Lot
0801052	0.13	STEEL	Zn	10

Nylon Roller
 Rodamiento Nylon

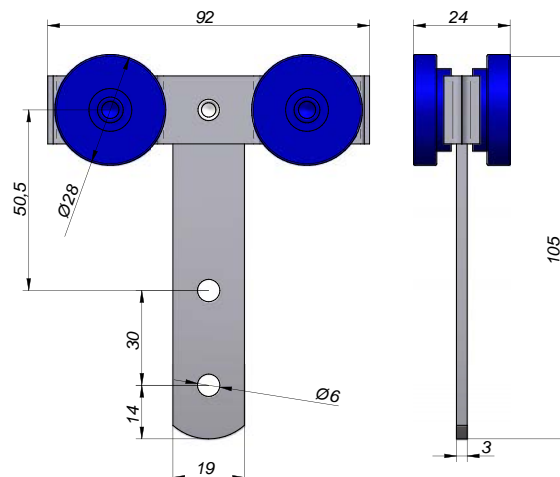



ROLLERS / ROLLEN / RULETAS

CURTAIN ACCESSORIES / PLANEN-ZUBEHÖR / ACCESORIOS DE LONAS

Roller Simple Ø38x30 Rol. Steel
Laufrolle Einfach Ø38x30 Rol. Stahl
Ruleta Simple Ø38x30 Rod. Acero

Ref	Kg	Mat	Lot
0801110	0.22	STEEL	10

Steel Roller
Rodamiento Acero

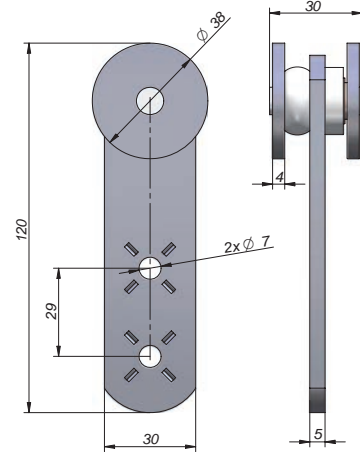
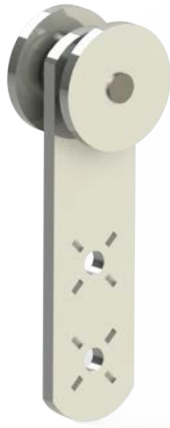

Roller Simple Ø30x24 Rol. Steel
Laufrolle Einfach Ø30x24 Rol. Stahl
Ruleta Simple Ø30x24 Rod. Acero

Ref	Kg	Mat	Lot
0801150	0.1	STEEL	10

Steel Roller
Rodamiento Acero

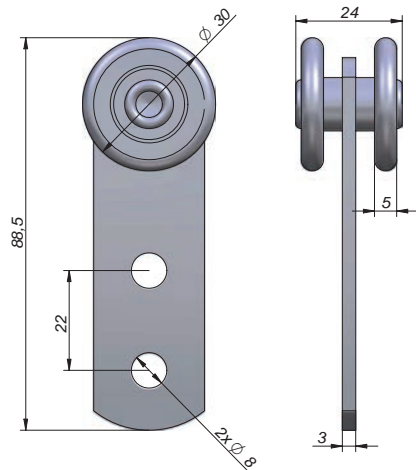

Roller Double Ø30x23 Rol. Steel
Laufrolle Doppelt Ø30x23 Rol. Stahl
Ruleta Doble Ø30x23 Rod. Acero

Ref	Kg	Mat	Lot
0801160	0.2	STEEL	10

Steel Roller
Rodamiento Acero

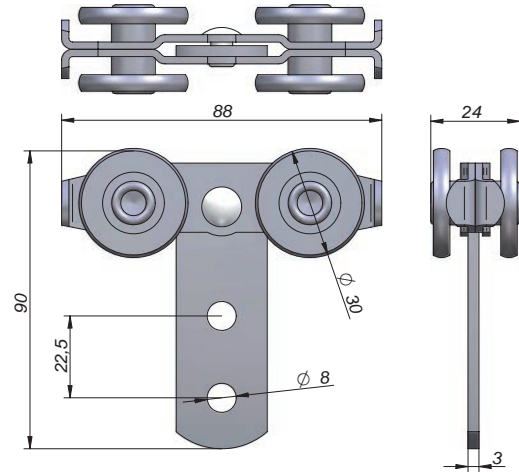

Roller Double Ø44x32 Rol. Steel
Laufrolle Doppelt Ø44x32 Rol. Stahl
Ruleta Doble Ø44x32 Rod. Acero

Ref	Kg	Mat	Lot
0801170	0.46	STEEL	10

Steel Roller
Rodamiento Acero

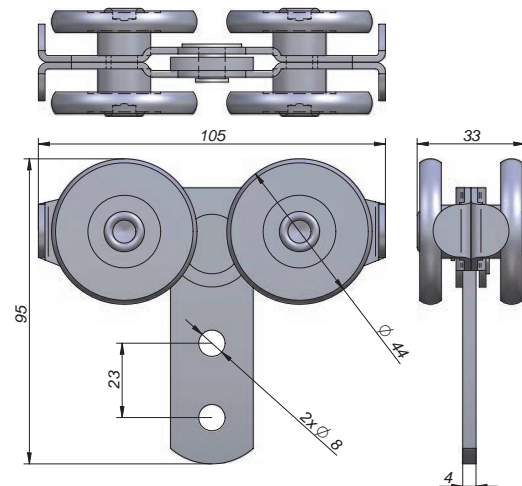



Roller Double Ø20x25 Rol. Steel Bolt 40 mm. w/Stop Nut
 Laufrolle Doppelt Ø20x25 Rol. Stahl Schraube 40 mm. m/Mutter
 Ruleta Doble Ø20x25 Rod. Acero Tor. 40 mm. c/Tuerca

Ref	Kg	Mat	Sup/Finish Acabado	Metric	Lot
0801113	0.16	STEEL	Zn	M8	10

Steel Roller | Stop Nut | Bolt 40 mm.
 Rodamiento Acero | Tor 40 mm. | Tuerca Autoblocante

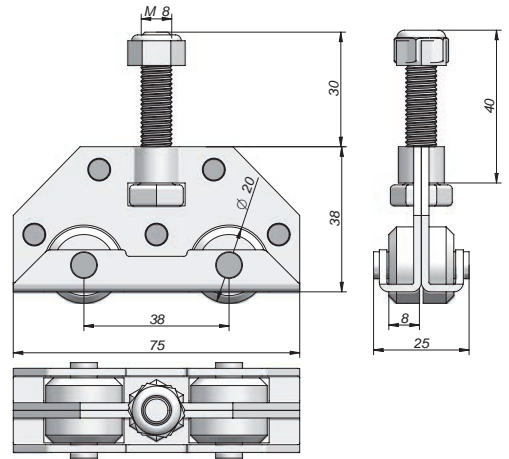
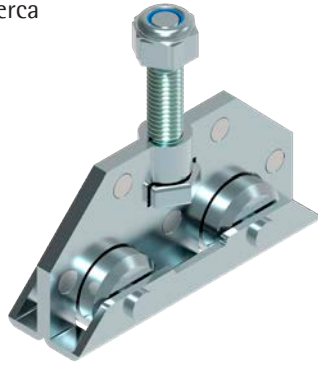

Roller Double Ø20x25 Rol. Nylon Bolt 40 mm. w/Stop Nut
 Laufrolle Doppelt Ø20x25 Rol. Nylon Schraube 40 mm. m/Mutter
 Ruleta Doble Ø20x25 Rod. Nylon Tor. 40 mm. c/Tuerca

Ref	Kg	Mat	Sup/Finish Acabado	Metric	Lot
0801116	0.15	STEEL	Zn	M8	10

Nylon Roller | Stop Nut | Bolt 40 mm.
 Rodamiento Nylon | Tor 40 mm. | Tuerca Autoblocante

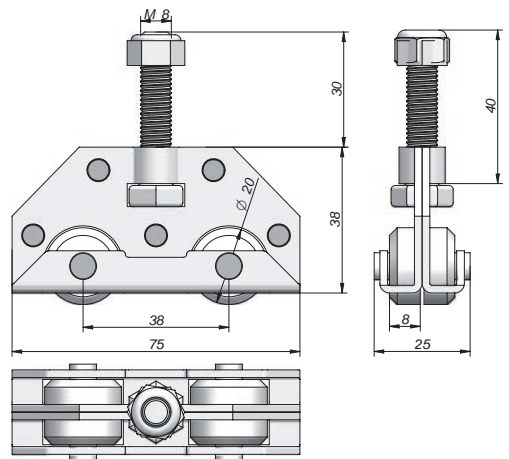
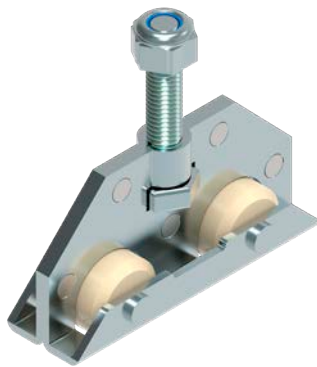

Roller Double Ø31x19 Rol. Red Nylon
 Laufwagen Ø31x19 Rol. Nylon Rot
 Carro Rodamientos Nylon Rojos Doble Ø31x19

Ref	Kg	Mat	Sup/Finish Acabado	Col	Thickn. Espesor	Lot
0801117	0.17	STEEL	Zn	Yellow	5	4

Nylon Red Roller
 Rodamiento Nylon Rojo

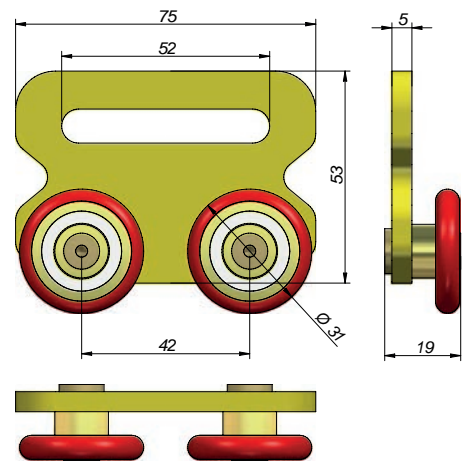
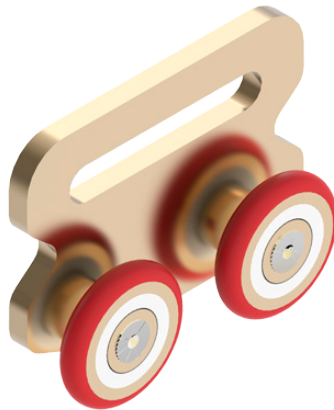

Roof Curtain Carriage Smz Ø30x24
 Dach Planen-Laufwagen Smz Ø30x24 Roulement Nylon
 Carro Lona Doble Ø30x24 Rod. Nylon Rueda Nylon

Ref	Kg	Mat	Col	Pack
0801124	2.05	STEEL	Yellow	10

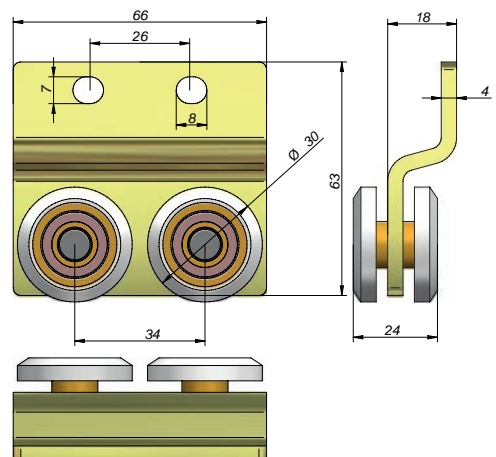



ROLLERS / ROLLEN / RULETAS

CURTAIN ACCESSORIES / PLANEN-ZUBEHÖR / ACCESORIOS DE LONAS

Carriage Ø30x25 for Tipper Steel Roller
Laufwagen Ø30x25 für Kipper Stahl Rolle
Carro Arquillo Ø30x25 Rueda Acero para Bañeras

Ref	Kg	Mat	Lot
0801118	0.28	STEEL	10

For Tipper Truck | Steel Roller
Carro Arquillo plegador para bañeras | Rodamiento Acero

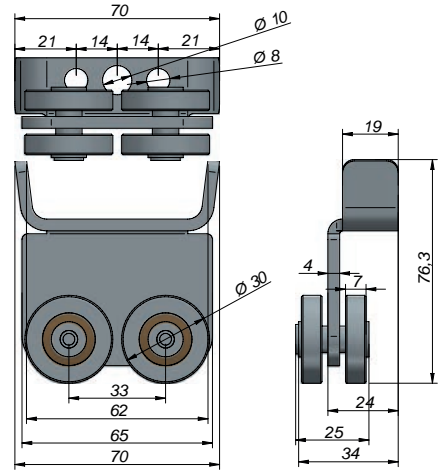

Carriage Ø30x25 for Tipper Nylon Roller
Laufwagen Ø30x25 für Kipper Nylon Rolle
Carro Arquillo Ø30x25 Rueda Nylon

Ref	Kg	Mat	Lot
0801119	0.12	STEEL	10

For Tipper Truck | Nylon Roller
Carro Arquillo plegador para bañeras | Rodamiento Nylon

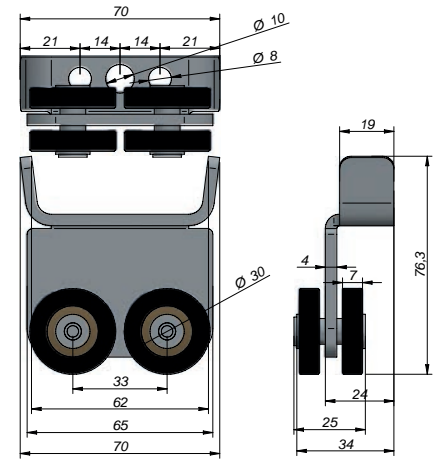

Carriage Ø29x27 for Tipper, Steel Roller
Laufwagen Ø29x27 für Kipper, Stahl Rolle
Carro Arquillo Ø29x27 Rueda Acero

Ref	Kg	Mat	Sup/Finish Acabado	Pack
0801125	2.6	STEEL	Zn	10

For Tipper Truck | Steel Roller
Carro Arquillo plegador para bañeras | Rodamiento Acero

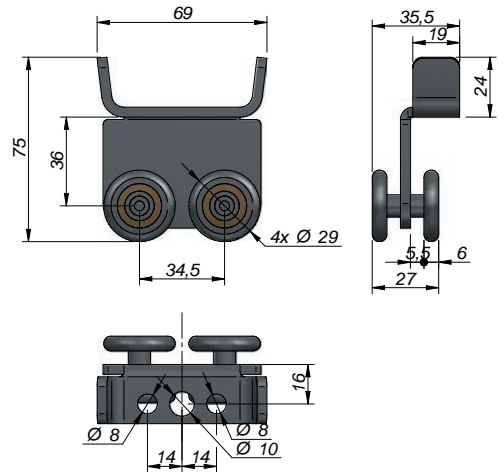

Up Carriage Curtain ADA-SLIDER Rol. Nylon
Planen-Laufrolle ADA-SLIDER Oben, Nylon
Carro Superior Lona ADA-SLIDER Rod. Nylon

Ref	Kg	Mat	Sup/Finish Acabado	Pos	Lot
0802113	0.12	STEEL	KTL	▲▼	10

Nylon Roller
Rodamiento Nylon

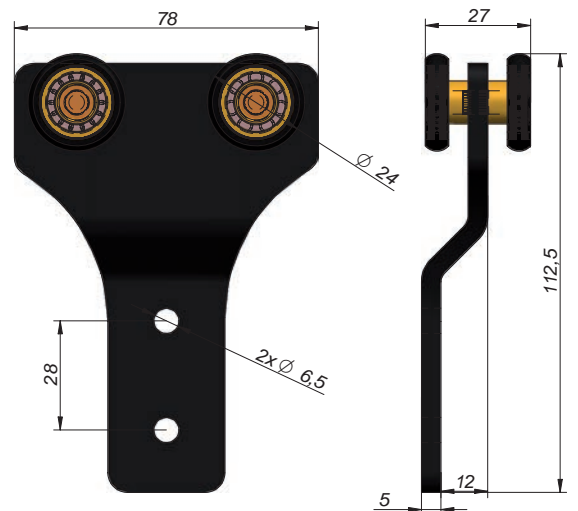

Up Carriage Door ADA-SLIDER Rol. Nylon
 Tür-Laufwagen ADA-SLIDER Oben, Nylon
 Carro Superior Puerta ADA-SLIDER Rod. Nylon

Ref	Kg	Mat	Sup/Finish Acabado	Pos	Lot
0802123	0.9	STEEL	KTL		1

Nylon Roller
 Rodamiento Nylon

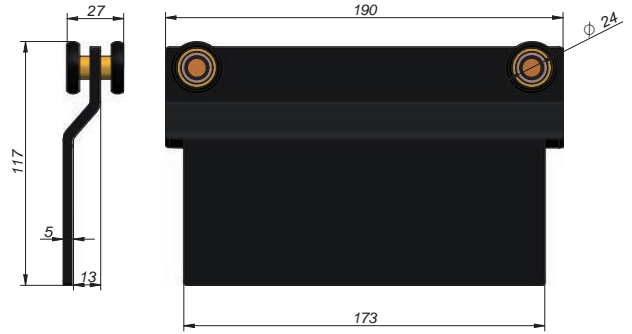
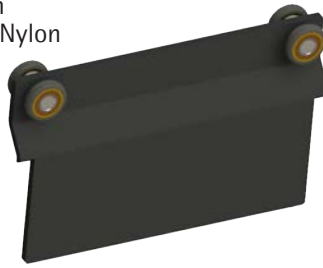

Down Carriage Curtain ADA-SLIDER Rol. Nylon
 Planen-Laufrolle ADA-SLIDER Unten, Nylon
 Carro Inferior Lona ADA-SLIDER Rod. Nylon

Ref	Kg	Mat	Sup/Finish Acabado	Pos	Lot
0802133	0.28	STEEL	KTL		1

Nylon Roller
 Rodamiento Nylon

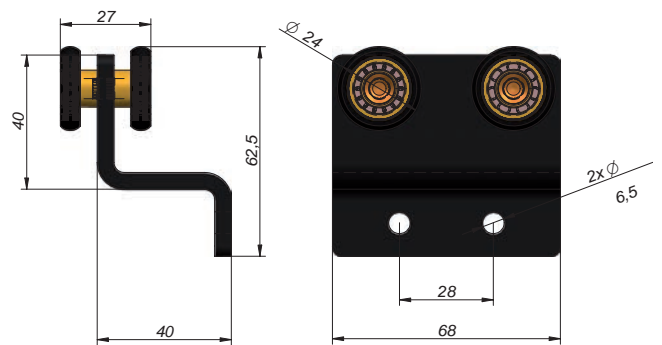

Down Carriage Door ADA-SLIDER Rol. Nylon
 Tür-Laufwagen ADA-SLIDER Unten, Nylon
 Carro Inferior Puerta ADA-SLIDER Rod. Nylon

Ref	Kg	Mat	Sup/Finish Acabado	Pos	Lot
0802143	2.53	STEEL	KTL		1
0802153	2.53	STEEL	KTL		1

Nylon Roller
 Rodamiento Nylon

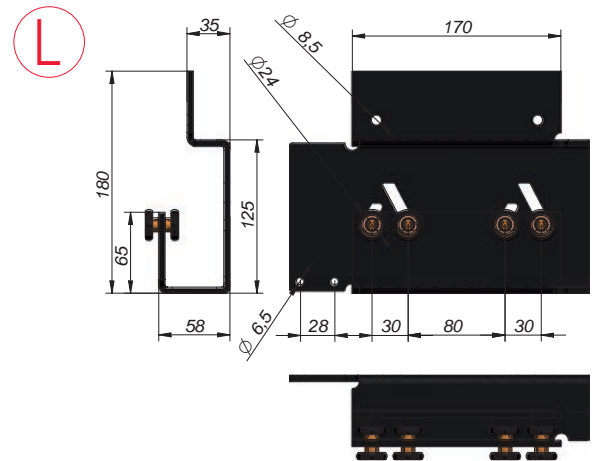

Wheel Nylon ADA-SLIDER
 Roller Nylon ADA-SLIDER
 Rueda Nylon ADA-SLIDER

Ref	Kg	Mat	Pack
0801396	0.1	Ny	10

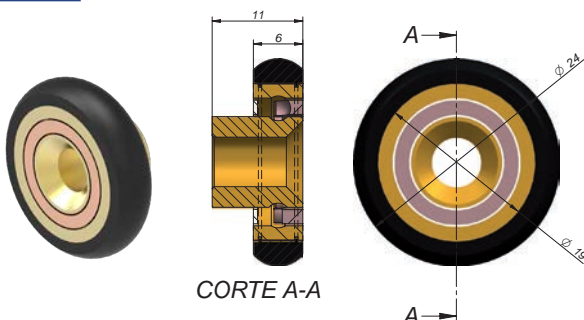

Steel Shafts 28xØ6
 Rollenachse Stahl 28xØ6
 Remache Acero Cincado Semitubular 28xØ6

Ref	Kg	Mat	Sup/Finish Acabado	Pack
0801397	0.06	STEEL	Zn	10

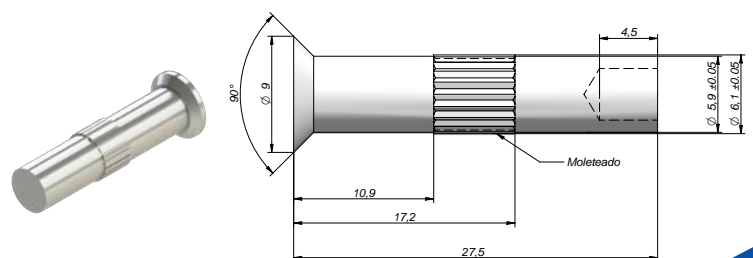

Carriage Ø26x26 H230 Zinc Plated Steel, Double
 Laufwagen Doppel Ø26x26 H230 Verzinkt Stahl
 Carro Doble Acero Cincado Ø26x26 H230

Ref	Kg	Mat	Sup/Finish Acabado	Col	Article	Lot
0801148	0.73	STEEL	Zn		OE1160355	1

NEW

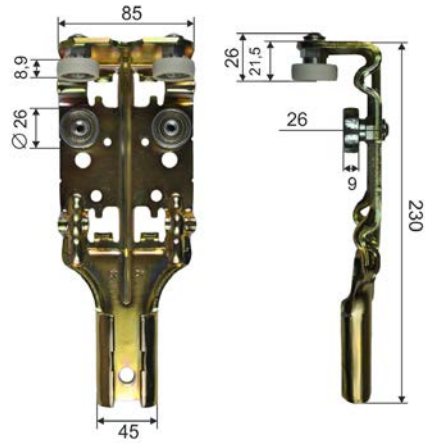

Roof Connector Zinc Plated Steel 590x140 Ø6
 Roof Connector Zinc Plated Steel 590x140 Ø6
 Arquillo Techo Acero Cincado 590x140 Ø6

Ref	Kg	Mat	Sup/Finish Acabado	Article	Lot
0801147	0.42	STEEL	Zn	OE334852	1

NEW

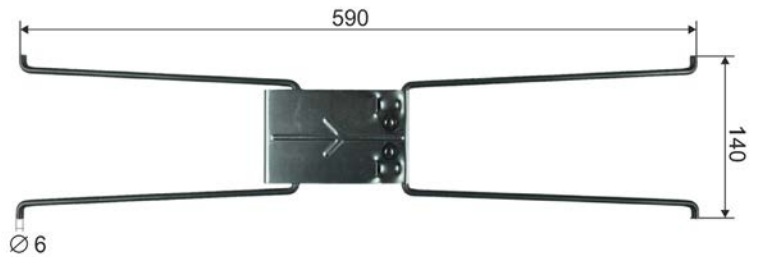

Roller Ø31,5x17, Double Rol. Nylon
 Laufwagen Doppel Ø31,5x17 Rol. Nylon
 Carro Rodamiento Nylon Ø31,5x17

Ref	Kg	Mat	Sup/Finish Acabado	Thickn. Espesor	Article	Pack
0801112	1.77	STEEL	Zn	5	OE4038085810	10

Nylon White Roller
 Rodamiento Nylon Blanco

NEW

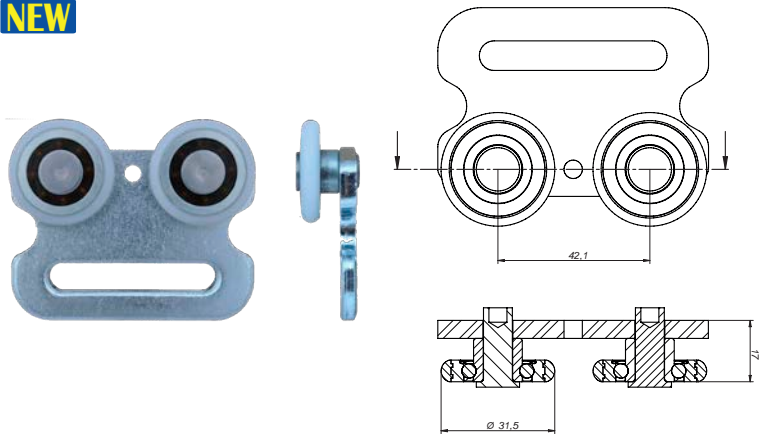

Roller Ø31,5x17, Double Rol. Nylon
 Laufrolle Doppelt Ø31,5x17
 Ruleta Doble Ø31,5x17

Ref	Kg	Mat	Sup/Finish Acabado	Article	Pack
0801122	0.42	STEEL	Zn	OE6353160	2

Nylon Roller
 Rodamiento Nylon

NEW

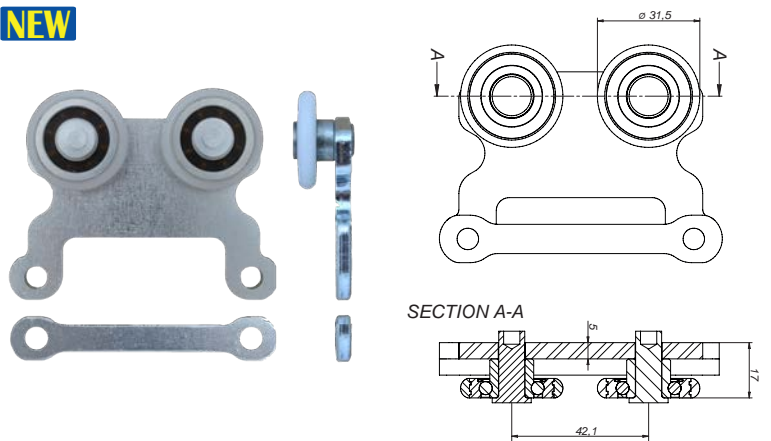



Roller Ø30,5x27 H110, Double Rol. Nylon
 Laufrolle Doppelt Ø30,5x27 H110
 Ruleta Doble Ø30,5x27 H110

NEW

Ref	Kg	Mat	Sup/Finish Acabado	Article	Pack
0801143	0.66	STEEL	Zn	OE371333	2

Nylon Roller
Rodamiento Nylon

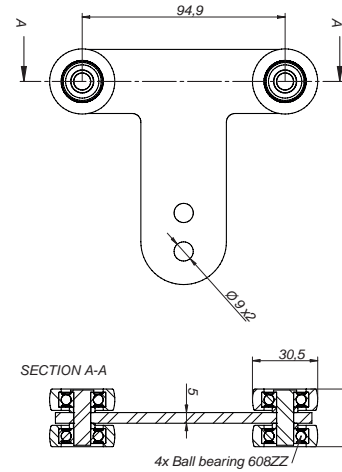

Roller Ø30,5x27 H96, Double Rol. Nylon
 Laufrolle Doppelt Ø30,5x27 H96
 Ruleta Doble Ø30,5x27 H96

NEW

Ref	Kg	Mat	Article	Pack
0801145	0.58	STEEL	OE306-52.130	2

Nylon Roller
Rodamiento Nylon

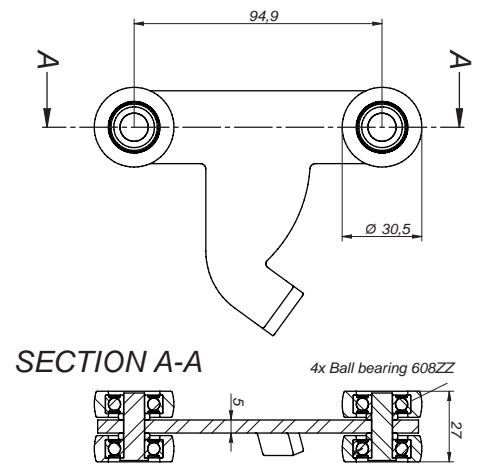

Roller Ø30,5x26 L160, Double Rol. Nylon
 Laufrolle Doppelt Ø30,5x26 L160
 Ruleta Doble Ø30,5x26 L160

NEW

Ref	Kg	Mat	Sup/Finish Acabado	Article	Pack
0801144	0.65	STEEL	Zn	OE1294061	2

Nylon Roller
Rodamiento Nylon

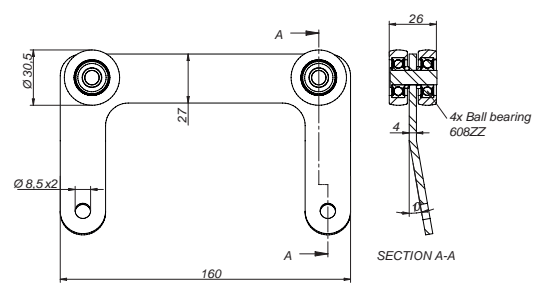

Carriage Ø22x21,5 L175 Zinc Plated Steel, Double
 Laufwagen Doppel Ø22x21,5 L175 Verzinkt Stahl
 Carro Acero Cincado Ø22x21,5 L175

NEW

Ref	Kg	Mat	Sup/Finish Acabado	Article	Lot
0801146	0.47	STEEL	Zn	OE6607528	2

Steel Roller
Roulement Acier

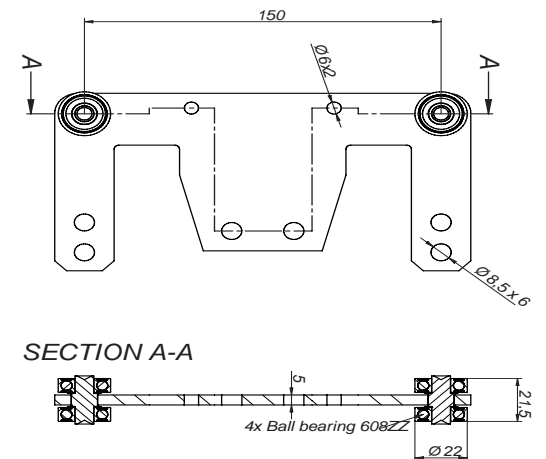

Roller Ø37x29,5, Simple Rol. Nylon
 Laufrolle Einfach Ø37x29,5 Rol. Nylon
 Ruleta Ø37x29,5 Rod. Nylon

NEW

Ref	Kg	Mat	Sup/Finish Acabado Acabado	Thickn. Acabado	Article	Pack
0801014	1.68	STEEL	Zn	5	OE1193343	10

Nylon Roller
 Rodamiento Nylon

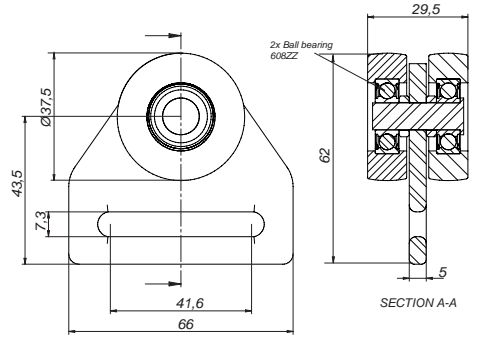
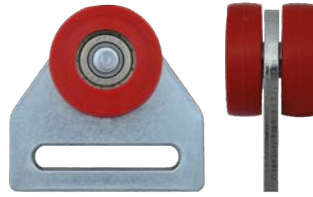

Roller, Simple Ø35x29 Rol. Nylon
 Laufrolle Einfach Ø35x29 Rol. Nylon
 Ruleta Ø35x29 Rod. Nylon

NEW

Ref	Kg	Mat	Sup/Finish Acabado Acabado	Thickn. Acabado	Article	Pack
0801018	1.63	STEEL	Zn	5	OE38030450	10

Nylon Roller
 Rodamiento Nylon

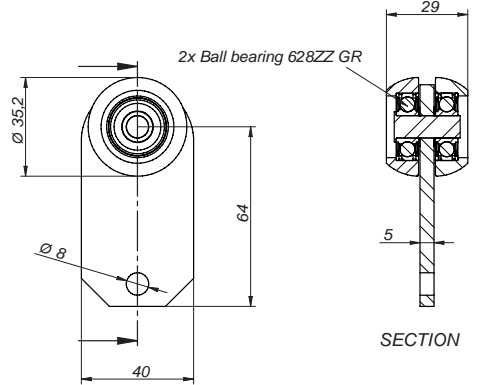

Roller, Simple Ø43x34,5 Rol. Nylon
 Laufrolle Einfach Ø43x34,5 Rol. Nylon
 Ruleta Ø43x34,5 Rod. Nylon

NEW

Ref	Kg	Mat	Sup/Finish Acabado Acabado	Thickn. Acabado	Article	Pack
0801127	0.42	STEEL	Zn	3		2

Nylon Roller
 Rodamiento Nylon

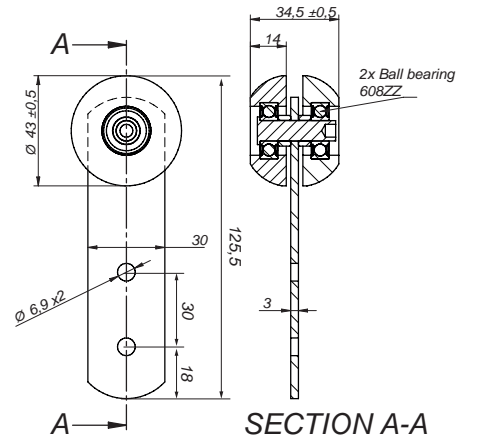

Roller, Simple Ø43x33,5 Rol. Nylon
 Laufrolle Einfach Ø43x33,5 Rol. Nylon
 Ruleta Ø43x33,5 Rod. Nylon

NEW

Ref	Kg	Mat	Sup/Finish Acabado Acabado	Thickn. Acabado	Article	Pack
0801128	0.352	STEEL	Zn	3		2

Nylon Roller
 Rodamiento Nylon

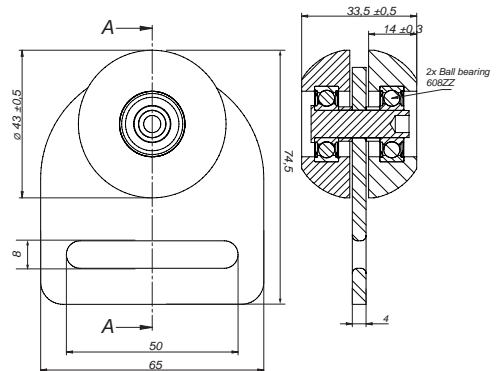

Roof Wheel Wheel Ø43x34,5 Nylon
 DachRoller Ø43x34,5 Nylon
 Rodamiento Techo Ø43x34,5 Nylon

Ref	Kg	Mat	Col	Pack
0801327	0.34	Ny	●	10

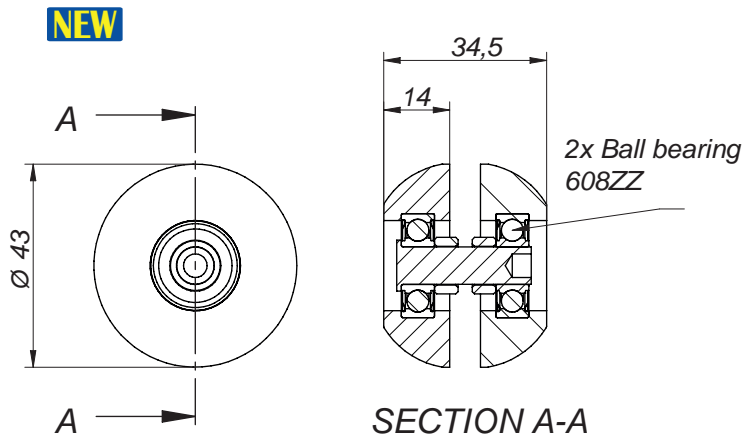

Wheel Ø24x7-8,5 Steel, Bolt M6
 Roller Ø24x7-8,5 Stahl, Schrauben M6
 Rodamiento Ø24x7-8,5 Acero, Tornillo M6

Ref	Kg	Mat	Metric	Article	Pack
0801318	0.37	STEEL	M6	OE6500389	10

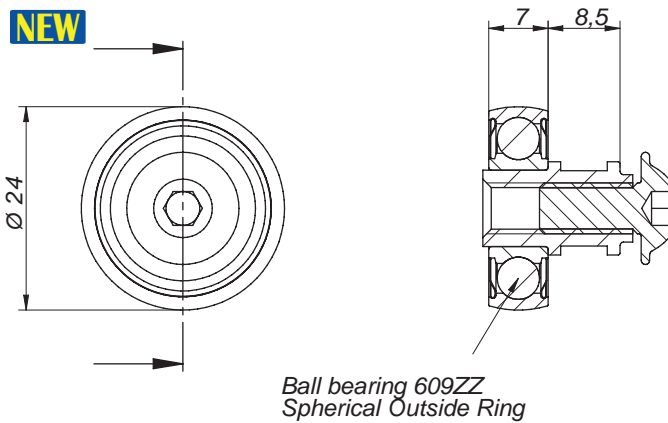

Wheel Ø24 M6 Nylon
 Roller Ø24 M6 Nylon
 Rodamiento Ø24 Tornillo M6 Nylon

Ref	Kg	Mat	Col	A	Metric	Article	Pack
0801314	0.33	Ny	●	8.8	M6	OE6352604	10
0802028	0.37	Ny	●	11.3	M6		10
0802029	0.5	Ny	●	19.1	M6		10

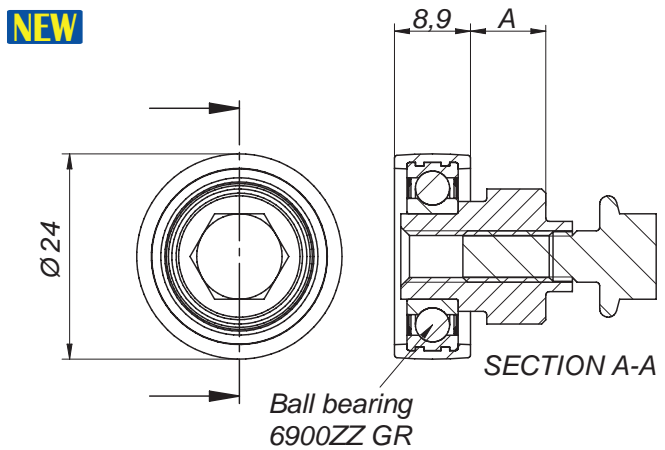

Wheel Ø26 M6 Nylon
 Roller Ø26 M6 Nylon
 Rodamiento Ø26 Tornillo M6 Nylon

Ref	Kg	Mat	Col	Metric	Pack
0801380	0.28	Ny	●	M6	10

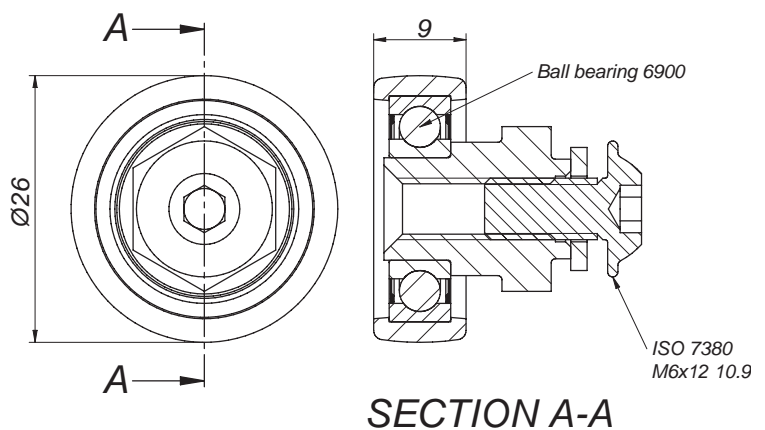



Roof Wheel Ø26x17 M6 Steel
DachRoller Ø26x17 M6 Stahl
Rodamiento Techo Ø26x17 M6 Acero

Ref	Kg	Mat	Metric	Pack
0801381	0.37	STEEL	M6	10

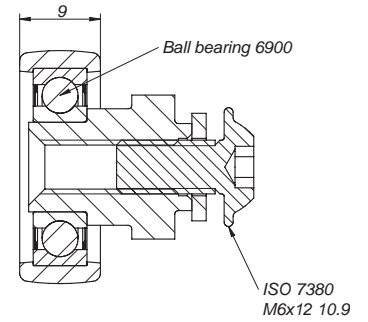
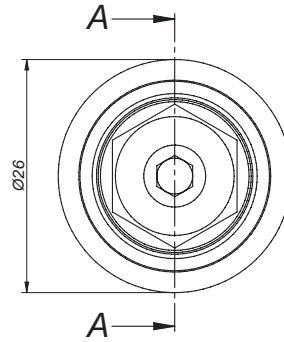

SECTION A-A

Roof Wheel Wheel Ø30x23 M8 Nylon
DachRoller Ø30x23 M8 Nylon
Rodamiento Techo Ø30x23 M8 Nylon

Ref	Kg	Mat	Metric	Pack
0801387	0.42	Ny	M8	10

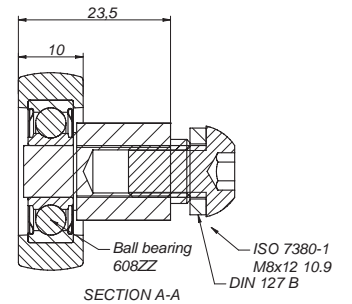
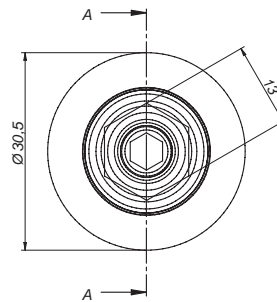

SECTION A-A

Roof Wheel Wheel Ø30x17 M6 Nylon
DachRoller Ø30x17 M6 Nylon
Rodamiento Techo Ø30x17 M6 Nylon

Ref	Kg	Mat	Metric	Pack
0801389	0.37	Ny	M6	10

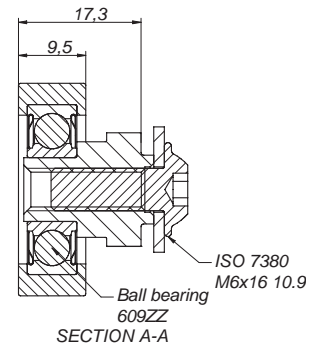
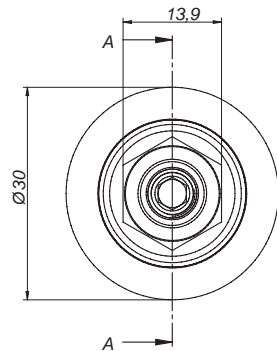

SECTION A-A

Wheel Ø31 M6 Nylon
Rollen Ø31 M6 Nylon
Rueda Ø31 M6 Nylon

Ref	Kg	Mat	Metric	Pack
0801391	0.3	Ny	M6	10

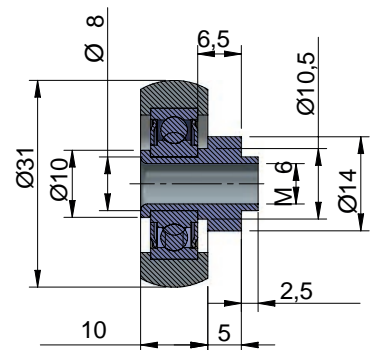
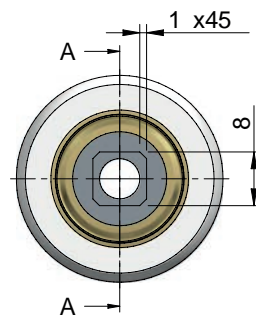

CORTE A-A

Wheel Ø35x11 Plastic
 Rolle Ø35x11 Kunststoff
 Rueda Ø35x11 Plástico

Ref	Kg	Mat	Pack
0801394	0.18		10

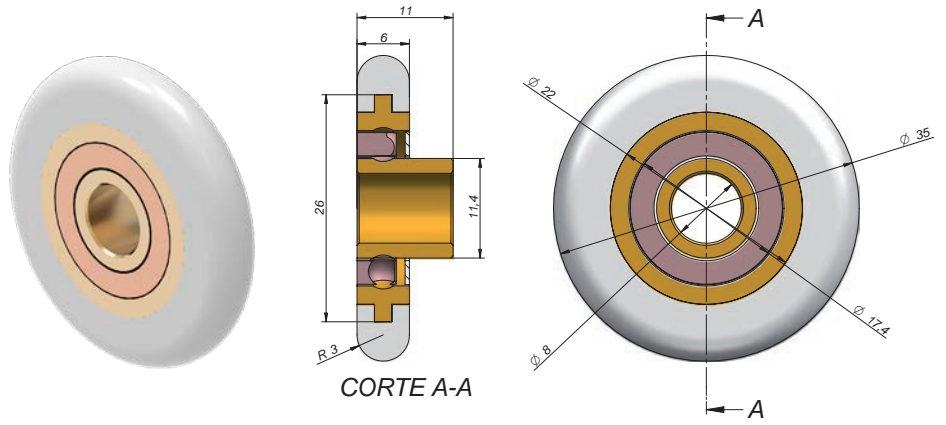

Steel Shaft 29,5xØ8
 Rollenachse Stahl 29,5xØ8
 Remache Acero Macizo 29,5xØ8

Ref	Kg	Mat	Sup/Finish Acabado	Pack
0801399	0.11	STEEL	Zn	10

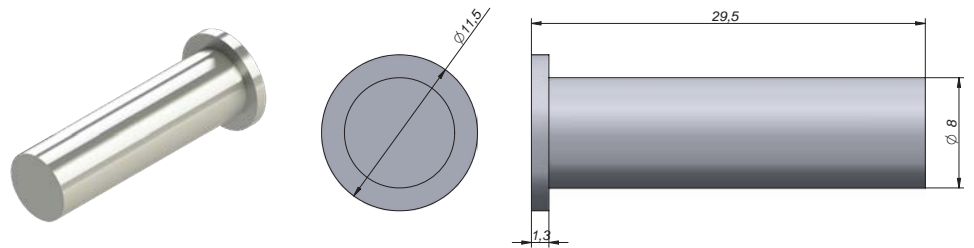

Wheel Ø26 Nylon, Bolt M6/16 with Washer
 Roller Ø26 Nylon, Schrauben M6/16 mit Unterlegscheibe
 Rodamiento Ø26 Acero, Tornillo M6/16 c/Arandela

Ref	Kg	Mat	Col	Metric	Article	Pack
0801312	0.29	Ny	●	M6	OE1057718	10

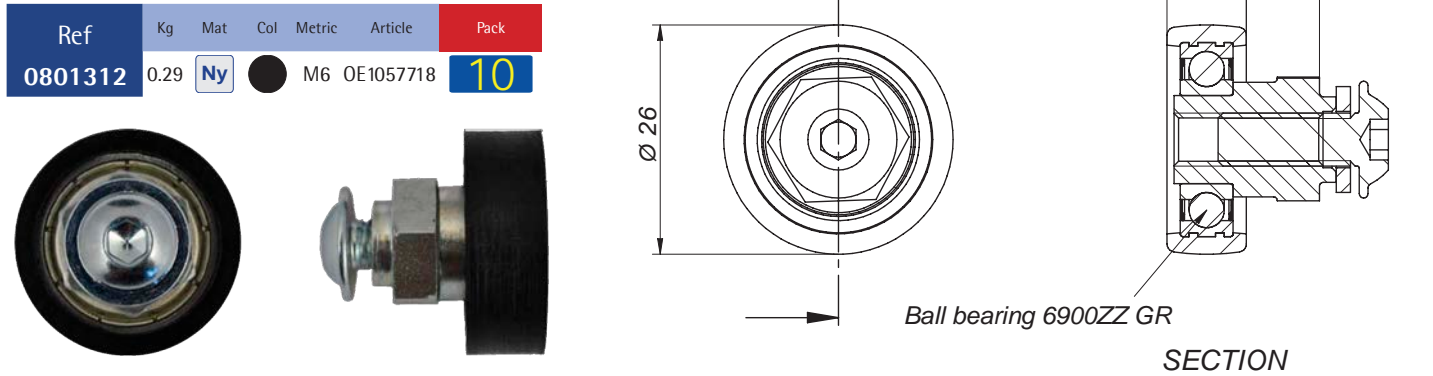

Wheel Ø26 Bolt M6 Nylon
 Roller Ø26 Schrauben M6 Nylon
 Rodamiento Ø26 Tornillo M6 Nylon

Ref	Kg	Mat	Col	A	Metric	Pack
0801326	0.32	Ny	●	8.5	M6	10

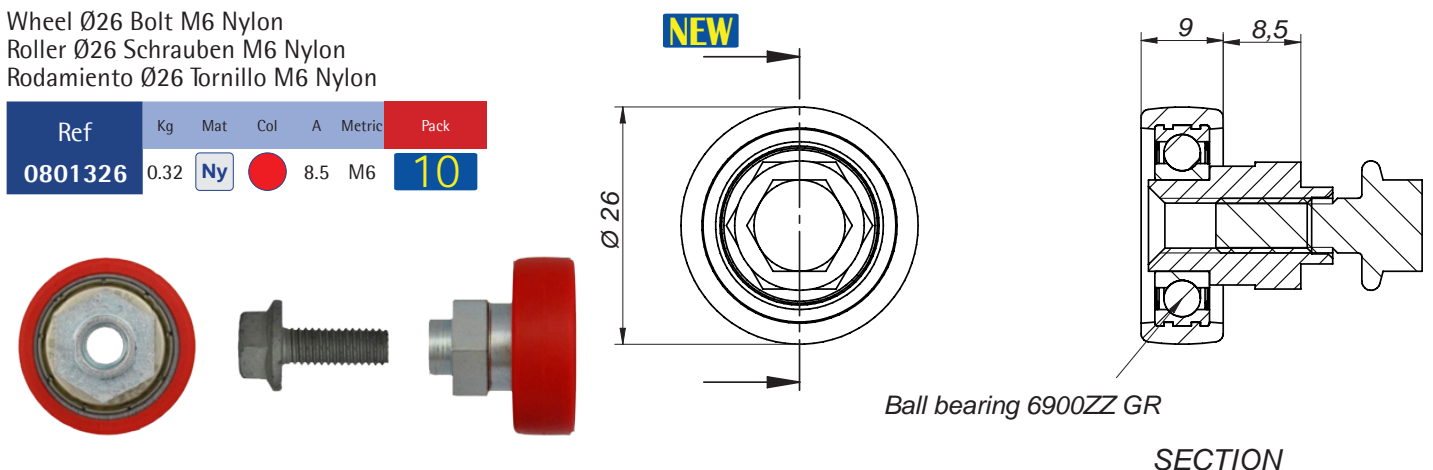



ROLLERS / ROLLEN / RULETAS

CURTAIN ACCESSORIES / PLANEN-ZUBEHÖR / ACCESORIOS DE LONAS

Wheel Ø24 Steel, Bolt M8 with Washer
Roller Ø24 Stahl, Schrauben M8 mit Unterlegscheibe
Rodamiento Ø24 Acero, Tornillo M8 c/Arandela

Ref	Kg	Mat	Metric	Article	Pack
0801310	0.29	STEEL	M8	OE66083004-83004	10

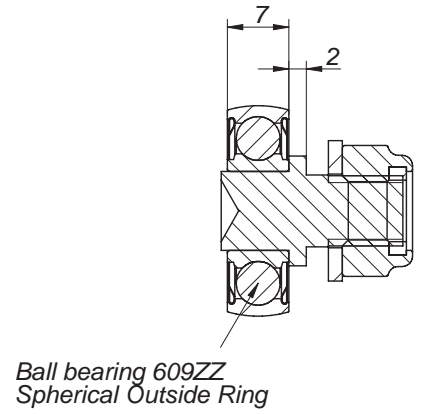
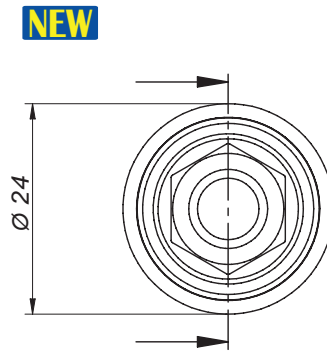
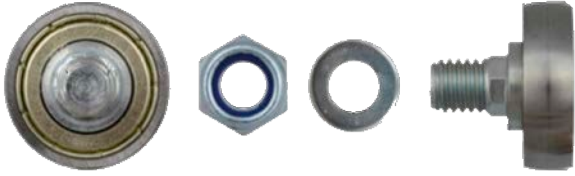

SECTION A-A

Wheel Ø31 Nylon, Bolt M6
Roller Ø31 Nylon, Schrauben M6
Rodamiento Ø31 Nylon, Tornillo M6

Ref	Kg	Mat	Col	Metric	Pack
0801322	0.31	Ny	○	M6	10

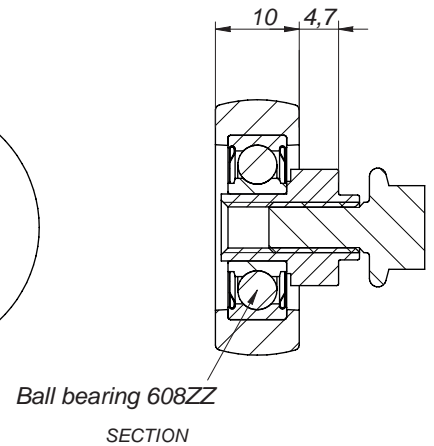
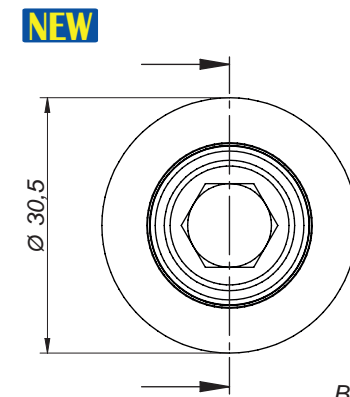

Wheel Ø31 Nylon, Bolt M6 with Washer
Roller Ø31 Nylon, Schrauben M6 mit Unterlegscheibe
Rodamiento Ø31 Nylon, Tornillo M6 c/Arandela

Ref	Kg	Mat	Col	Metric	Article	Pack
0801324	0.37	Ny	○	M6	OE1016466	10

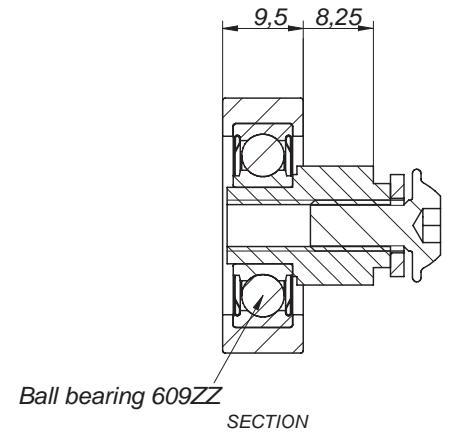
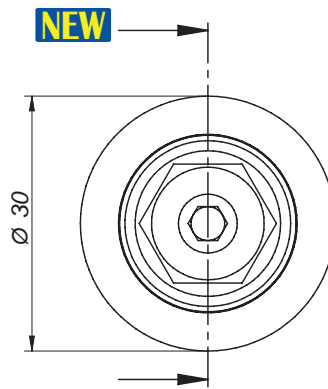
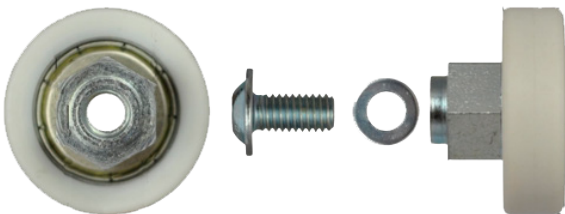

Wheel Ø24x7-7,25 Steel, Bolt M6
Roller Ø24x7-7,25 Stahl, Schrauben M6
Rodamiento Ø24x7-7,25 Acero, Tornillo M6

Ref	Kg	Mat	Metric	Article	Pack
0801316	0.37	STEEL	M6	OE801584	10

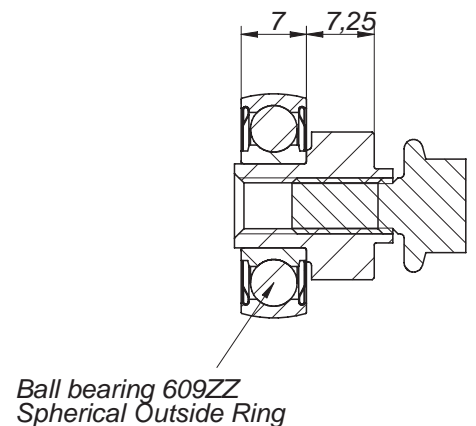
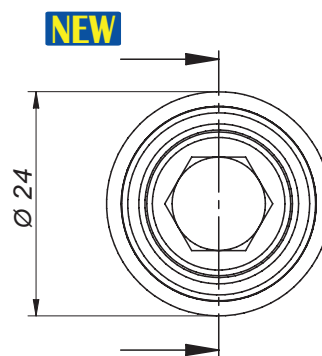



SECTION



List of Rollers-Profiles
 Rollen-Profil Aufstellung
 Tabla de aplicaciones Ruletas-Perfiles

CURTAIN ACCESSORIES / PLANEN-ZUBEHÖR / ACCESORIOS DE LONAS

Ref.	Description Beschreibung Descripción						
							1403030
0801007	Roller Ø35x30 Nylon Wheel beveled edge <i>Roller Simple Ø35x30 Rol. Nylon</i> Ruleta Ø35x30 Rod. Nylon biselado					✓	
0801012	Roller Ø36x30 Nylon Wheel <i>Roller Simple Ø36x30 Rol. Nylon</i> Ruleta Ø36x30 Rod. Nylon					✓	
0801016	Roller Ø36x30 Nylon Wheel <i>Roller Simple Ø36x30 Rol. Nylon</i> Ruleta Ø36x30 Rod. Nylon					✓	
0801110	Roller Ø38x30 Steel Wheel <i>Roller Simple Ø38x30 Rol. Stahl</i> Ruleta Ø38x30 Rod. Acero			✓	✓		
0801170	Roller Ø44x32 Steel Wheel <i>Roller Doppel Ø44x32 Rol. Stahl</i> Ruleta Ø44x32 Rod. Acero				✓		
0802113	Up Curtain Carriage ADA-SLIDER Ø25x27 Nylon Wheel <i>Laufwagen Plane ADA-SLIDER Ø25x27 Oben Rol. Nylon</i> Carro Sup. Lona ADA-SLIDER Ø25x27 Rod. Nylon		✓				✓
0802123	Up Door Carriage ADA-SLIDER Ø25x27 Nylon Wheel <i>Laufwagen Tür ADA-SLIDER Ø25x27 Oben Rol. Nylon</i> Carro Sup. Puerta ADA-SLIDER Ø25x27 Rod. Nylon		✓				✓
0802133	Down Curtain Carriage ADA-SLIDER Ø25x27 Nylon Wheel <i>Laufwagen Plane ADA-SLIDER Ø25x27 Rol. Nylon</i> Carro Inferior Lona ADA-SLIDER Ø25x27 Rod. Nylon		✓				✓
0802143 0802153	Down Door Carriage ADA-SLIDER Ø25x27 Nylon Wheel <i>Laufwagen Tür Ø25x27 Unten Rol. Nylon</i> Carro Inferior Puerta ADA-SLIDER Ø25x27 Rod. Nylon		✓				✓



ADATENSIONER

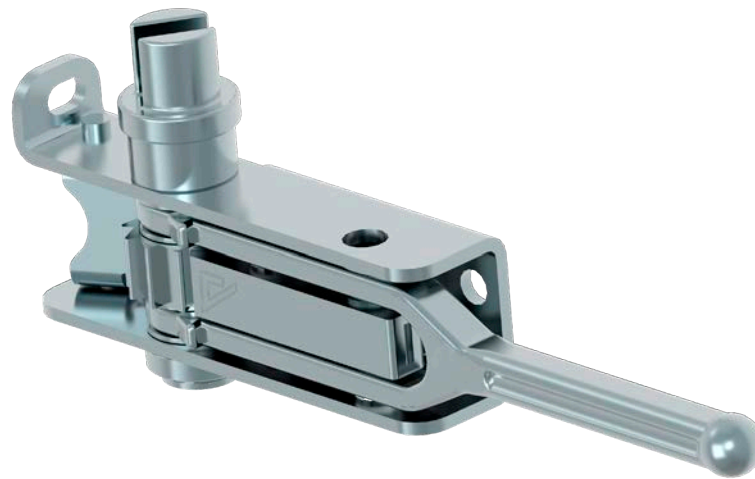
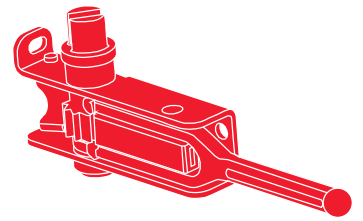

CURTAIN ACCESSORIES / PLANEN-ZUBEHÖR / ACCESORIOS DE LONAS

✓ **Slotted Drive Version**
(left & right)
Versión Adaptador Ranura
(izda & dcha)

✓ **Square Drive Version**
(left & right)
Versión Adaptador Cuadrado
(izda & dcha)

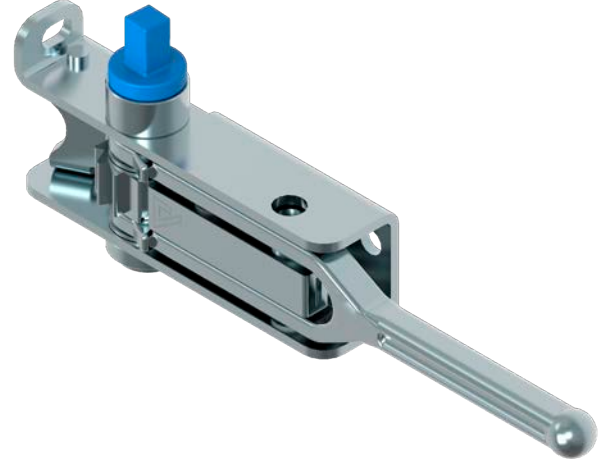
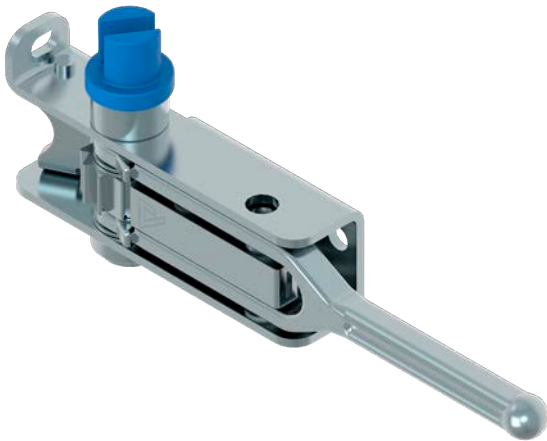

✓ **Antitheft System**
Sistema antirrobo

The design of the ADA-SAFETENSIONER, once closed, prevents any type of external manipulation that allows the slack of curtain, avoiding the access to interior of trailer.

El diseño del ADA-SAFETENSIONER, una vez cerrado, evita cualquier tipo de manipulación externa que permita el destensado de la lona, evitando así el acceso al interior del remolque.

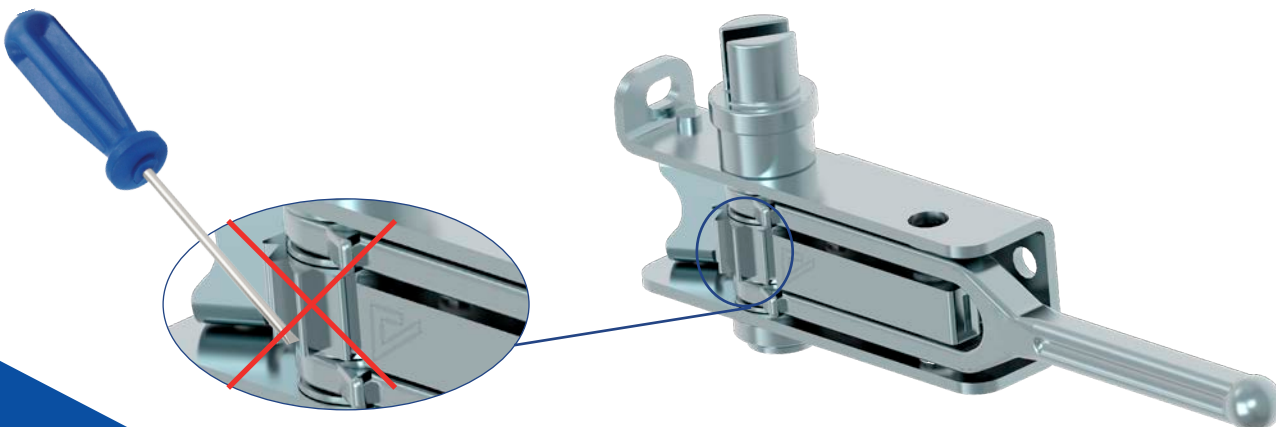

✓ Durability & Robustness Durabilidad & Robustez

- Saline fog chamber test: DIN EN ISO 9227
- Material: Zinc Nickel + Inorganic zinc laminated
- Test de Niebla Salina: DIN EN ISO 9227
- Material: Zinc Niquel + Zinc laminar inorgánico

Test: > 100.000 cycles

Test: > 100.000 ciclos



Ergonomic & Patented Ergonómico & Patentado



✓ Precision (Fine adjustment) / No lubrication Precisión (Ajuste fino) / No necesita lubricación



- 12 Teeth
- 12 Dientes

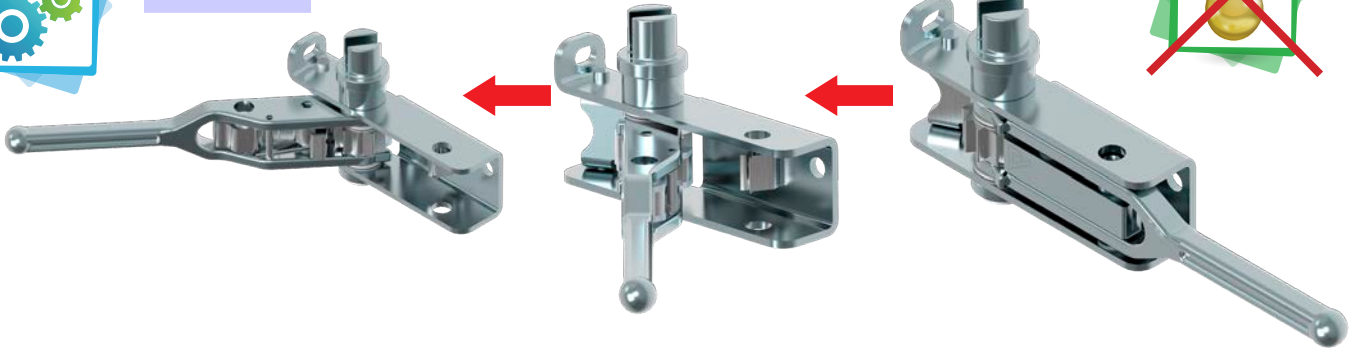

Ada-Tensioner Curtain Tensioner Slotted Drive
Ada-Tensioner Planspanverschluss m. Schlitzwelle
Ada-Tensioner Adaptador Ranura

Ref	Kg	Mat	Pos	Lot
1001180	1.5	STEEL		1
1001182	1.5	STEEL		1

Antitheft System | Durability & Robustness | Ergonomic | Patented |
No lubrication | Fine adjustment
Sistema antirrobo | Durabilidad/Robustez | Ergonómico | Patentado |
No necesita lubricación | Ajuste fino

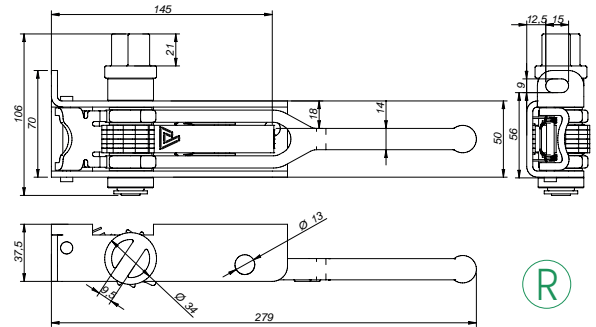
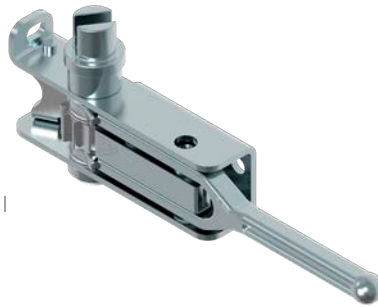

Ada-Tensioner Curtain Tensioner Square Drive
Ada-Tensioner Planspanverschluss Vierkantwelle
Ada-Tensioner Adaptador Cuadrado

Ref	Kg	Mat	Pos	Lot
1001184	1.5	STEEL		1
1001186	1.5	STEEL		1

Antitheft System | Durability & Robustness | Ergonomic | Patented |
No lubrication | Fine adjustment
Sistema antirrobo | Durabilidad/Robustez | Ergonómico | Patentado |
No necesita lubricación | Ajuste fino

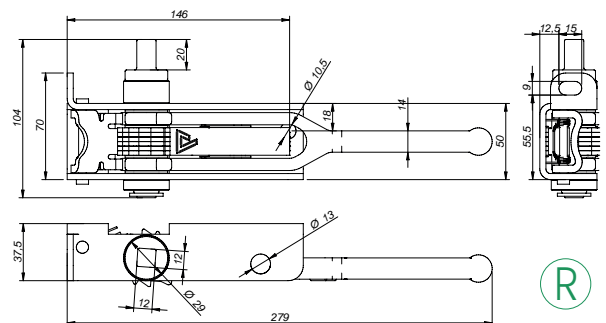
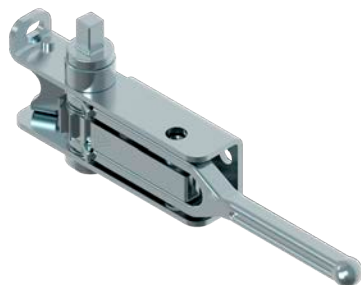



ADAHANDY

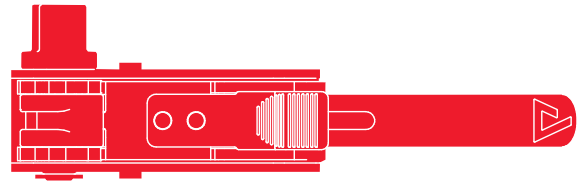

Our "COMPACT" version for TIGHT SPACES

Nuestra versión "COMPACT" para ESPACIOS REDUCIDOS

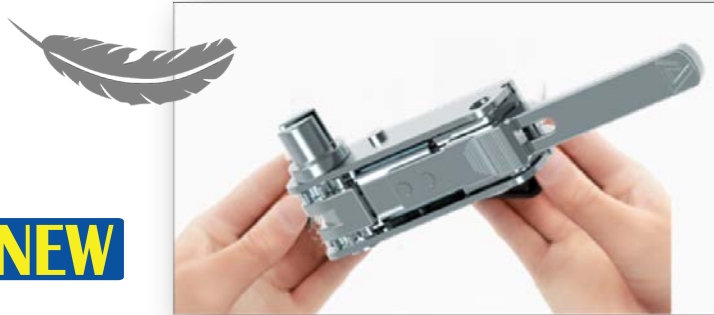

NEW

- ✓ **Short & Light**
Tamaño reducido y ligero

This tensioner will fit in any space and its weight is only 1,2 Kg.
Este tensor se ajusta a cualquier espacio y tiene un peso de sólo 1,2Kg.

- ✓ **Slotted Drive Version**
(left & right)
Versión Adaptador Ranura
(izda & dcha)

- ✓ **Square Drive Version**
(left & right)
Versión Adaptador Cuadrado
(izda & dcha)

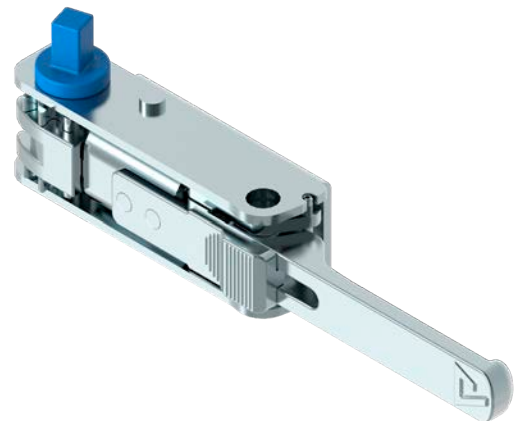
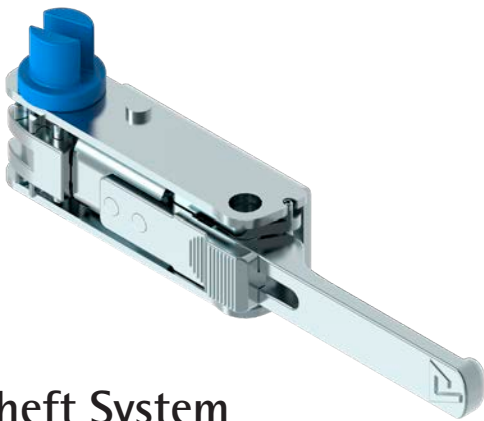

- ✓ **Antitheft System**
Sistema antirrobo

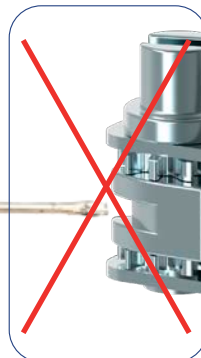

The design of the ADA-HANDY tensioner, once closed, prevents any type of external manipulation that allows the slack of curtain, avoiding the access to the interior of the trailer.

El diseño del ADA-HANDY, una vez cerrado, evita cualquier tipo de manipulación externa que permita el destensado de la lona, evitando así el acceso al interior del remolque.



✓ Durability & Robustness
Durabilidad & Robustez

- Test: > 100,000 cycles / > 100.000 ciclos
- Inorganic zinc laminated treatment against corrosion
Tratamiento anticorrosión inorgánico de zinc laminar

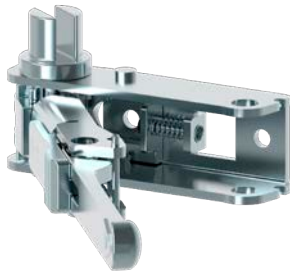

✓ Ergonomic & Patented
Ergonómico & Patentado

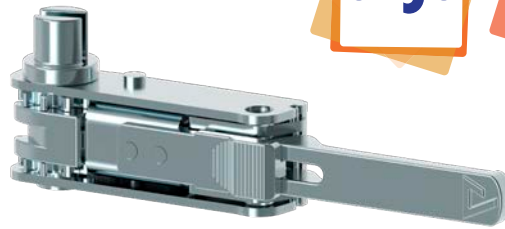

✓ Precision (Fine adjustment) / No lubrication
Precisión (Ajuste fino) / No necesita lubricación



Ada-Handy Curtain Tensioner Slotted Drive
Ada-Handy Planspanverschluss m. Schlitzwelle
Ada-Handy Adaptador Ranura

Ref	Kg	Mat	Pos	Lot
1001190	1.25	STEEL		1
1001192	1.25	STEEL		1

"COMPACT" version for tight spaces | Antitheft System |
Durability & Robustness | Ergonomic | Patented | No lubrication |
Fine adjustment
Versión "COMPACT" para espacios reducidos | Sistema antirrobo |
Durabilidad/Robustez | Ergonómico | Patentado | No necesita lubricación |
Ajuste fino

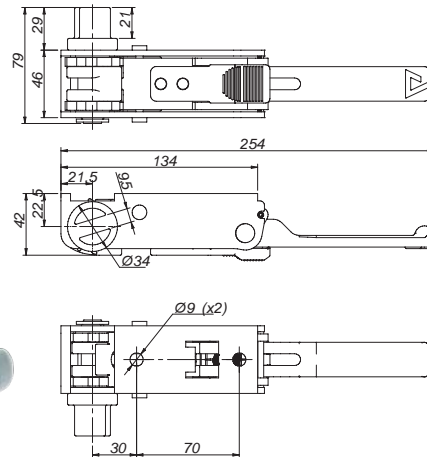
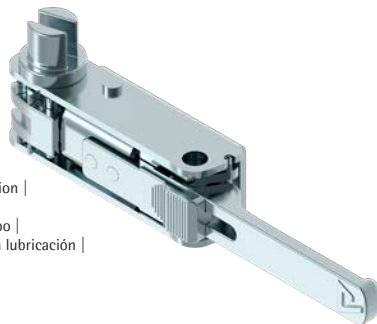

Ada-Handy Curtain Tensioner Square Drive
Ada-Handy Planspanverschluss Vierkantwelle
Ada-Handy Adaptador Cuadrado

Ref	Kg	Mat	Pos	Lot
1001194	1.3	STEEL		1
1001196	1.3	STEEL		1

"COMPACT" version for tight spaces | Antitheft System |
Durability & Robustness | Ergonomic | Patented | No lubrication |
Fine adjustment
Versión "COMPACT" para espacios reducidos | Sistema antirrobo |
Durabilidad/Robustez | Ergonómico | Patentado | No necesita lubricación |
Ajuste fino

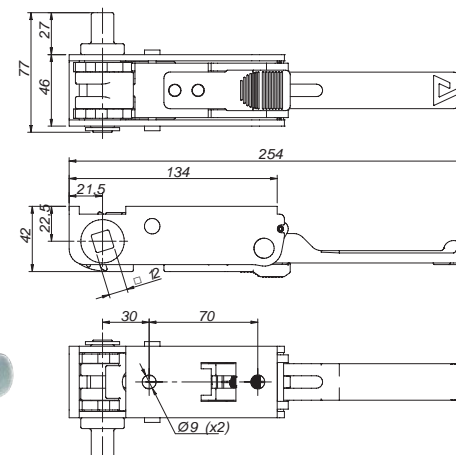
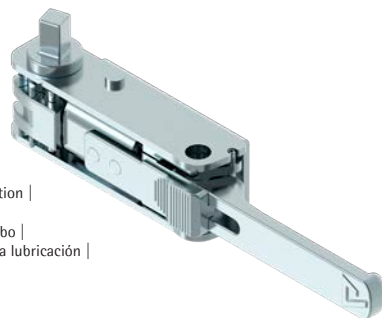



TENSIONER / PLANSpanNGETRIEBE / TENSORES

CURTAIN ACCESSORIES / PLANEN-ZUBEHÖR / ACCESORIOS DE LONAS

Curtain Tensioner 280x50x110
Planspannverschluss 280x50x110
Tensor Lona 280x50x110

Ref	Kg	Mat	Sup/Finish Acabado	Col	Pos	Lot
1001005	1.93	STEEL	Zn	Yellow	Eye	1
1001006	1.93	STEEL	Zn	Yellow	Eye	1

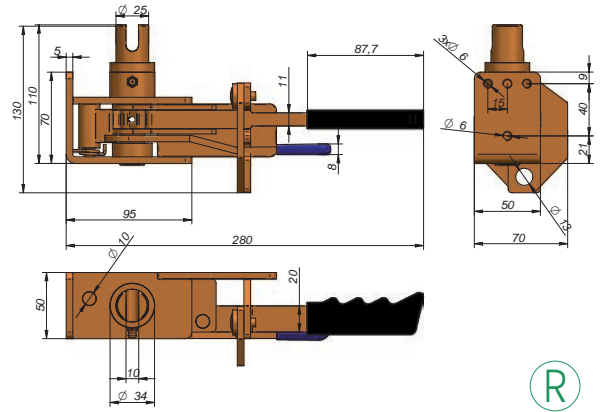
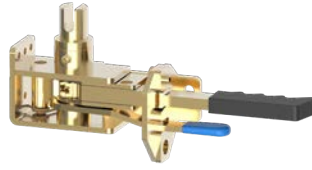

Curtain Tensioner 275x40x110
Planspannverschluss 275x40x110
Tensor Lona 275x40x110

Ref	Kg	Mat	Sup/Finish Acabado	Col	Pos	Lot
1001007	2	STEEL	Zn	Ag	Eye	1
1001008	2	STEEL	Zn	Ag	Eye	1

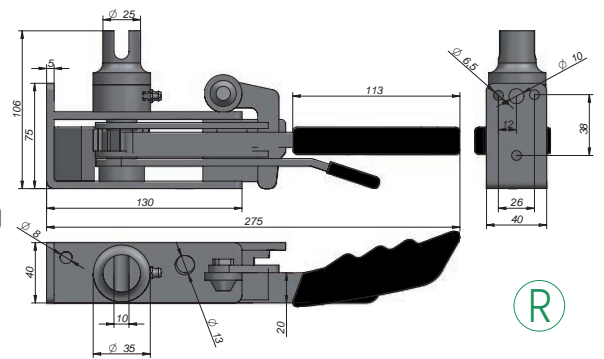

Curtain Tensioner (Telescopic Handle)
Planspanngetriebe (Ausziehbarer Handgriff)
Tensor Lona (Mango Telescópico)

Ref	Kg	Mat	Lot
1001156	2.5	STEEL	1

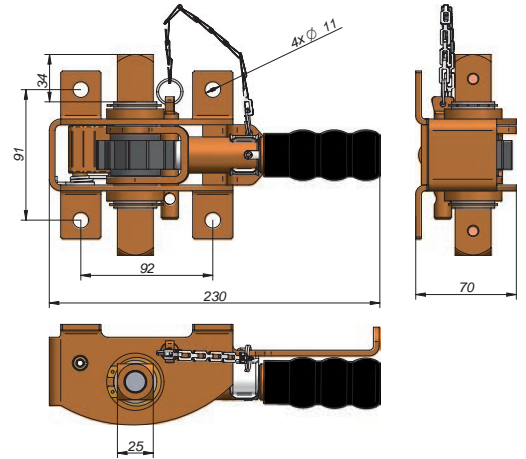
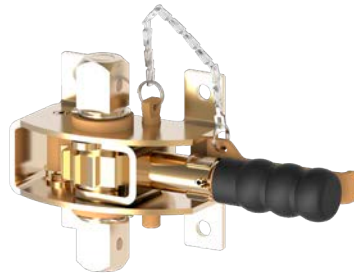

Articulated Curtain Tensioner (Telescopic Handle)
Planspanngetriebe (Ausziehbarer Handgriff)
Tensor Lona Articulado (Mango Telescópico)

Ref	Kg	Mat	Lot
1001157	2.2	STEEL	1

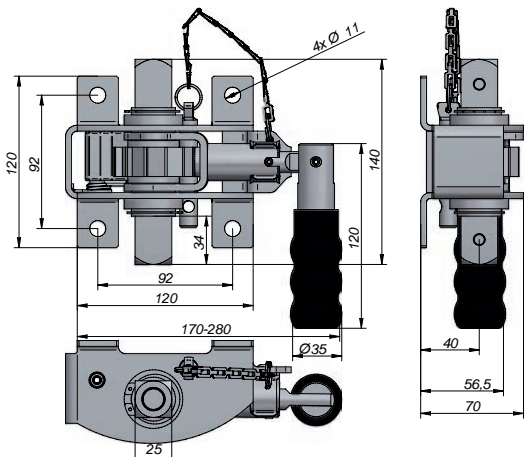

Curtain Tensioner (Endless)
Planspanngetriebe (Endlos)
Tensor Lona Sinfín

Ref	Kg	Mat	Pos	Lot
1001110	1.65	STEEL		1
1001120	1.65	STEEL		1

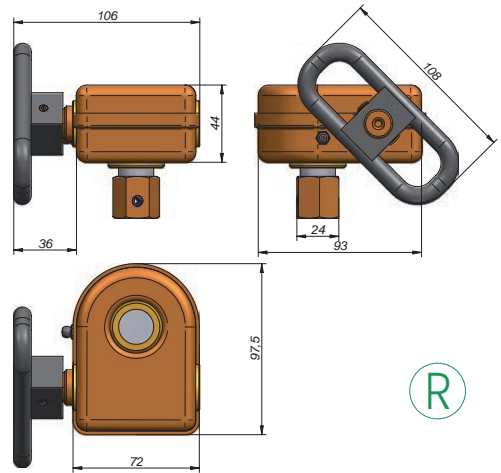
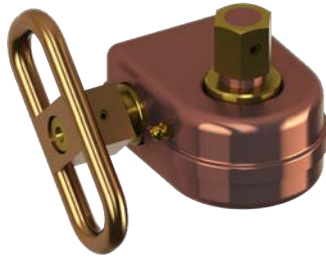

Curtain Tensioner Steel Galvanized Dacromet 12x12
Planspannverschluss Stahl Feuerverzinkt/Dacromet 12x12
Tensor de Lona Acero Galvanizado Dacromet 12x12

Ref	Kg	Mat	Sup/Finish Acabado	Pos	Lot
1001164	1.25	STEEL	Zn		1
1001166	1.25	STEEL	Zn		1

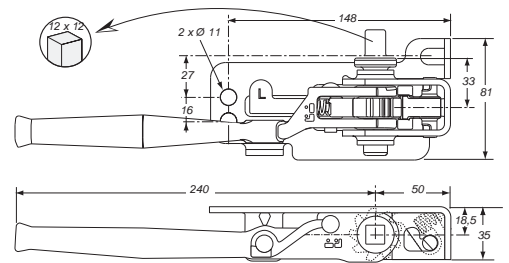

Curtain Tensioner 78x50x50 (14) (Handlelevel)
Planspanngetriebe 78x50x50 (14) (Kurbel)
Tensor Lona 78x50x50 (14) (Manivela)

Ref	Kg	Mat	Lot
1001070	1.07	STEEL	2

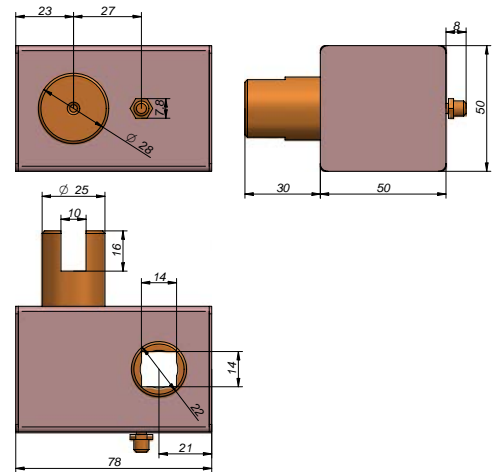
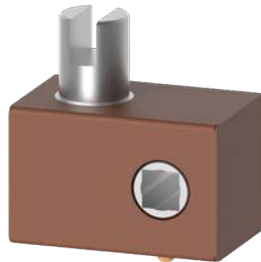

Handle Tensioner Ø10 (□14)
Kurbel für Planspanngetriebe Ø10 (□14)
Manivela Tensor Lona Ø10 (□14)

Ref	Kg	Mat	Sup/Finish Finish	Lot
1001420	0.22	STEEL	Zn	10

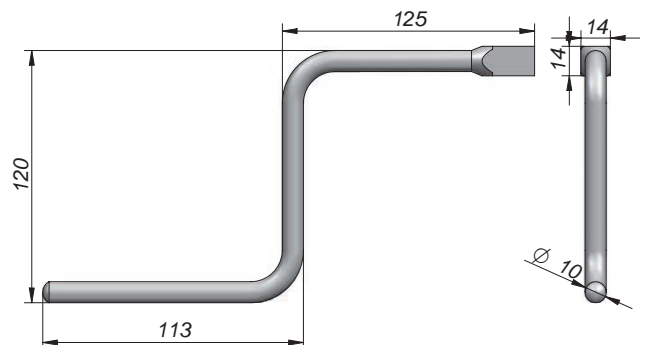



TENSIONER / PLANSPANNGETRIEBE / TENSORES

CURTAIN ACCESSORIES / PLANEN-ZUBEHÖR / ACCESORIOS DE LONAS

Curtain Tensioner 60x30x30 (10) (Handlelevel)
Planspanngetriebe 60x30x30 (10) (Kurbel)
Tensor Lona 60x30x30 (10) (Manivela)

Ref	Kg	Mat	Lot
1001074	0.28	STEEL	2

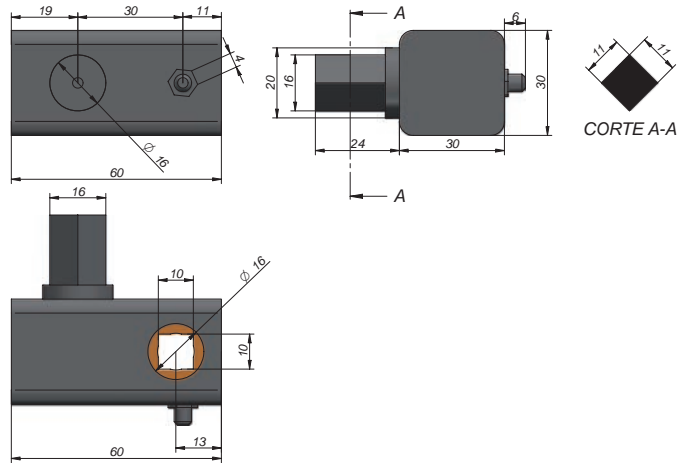

Handle Tensioner Ø10 (□10)
Kurbel für Planspanngetriebe Ø10 (□10)
Manivela Tensor Lona Ø10 (□10)

Ref	Kg	Mat	Sup/Finish Acabado	Lot
1001440	0.22	STEEL	Zn	2

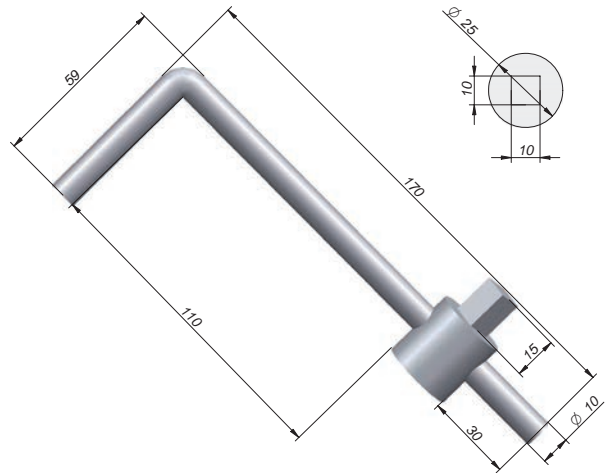

Curtain Tensioner 100x80x80 (Wheel)
Planspanngetriebe 100x80x80 (Rad)
Tensor Lona 100x80x80 (Rueda)

Ref	Kg	Mat	Pos	Lot
1001050	2.29	STEEL		1
1001060	2.29	STEEL		1

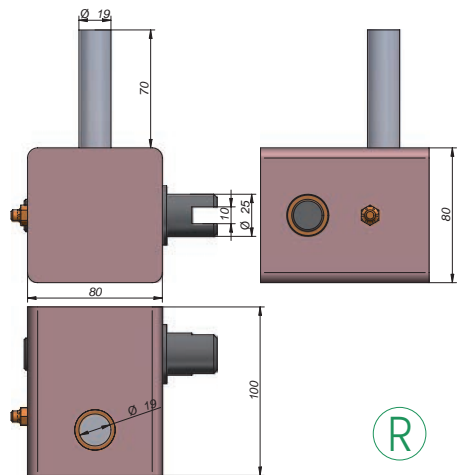
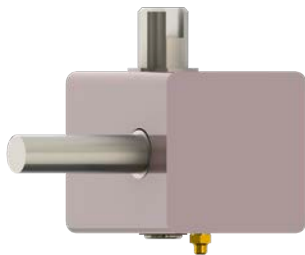

Curtain Tensioner Wheel
Aluminium-Spannrad
Rueda Tensor Lona

Ref	Kg	Mat	Lot
1001400	0.22		2

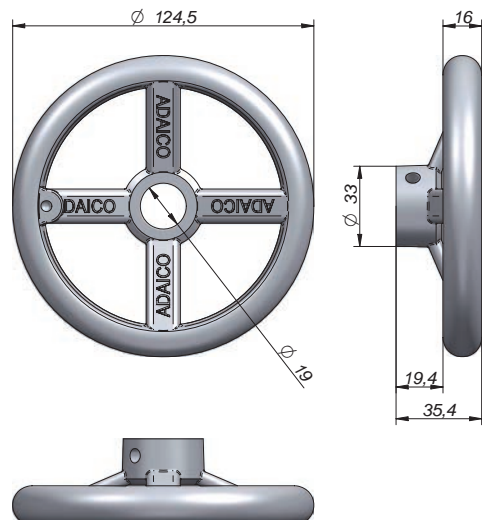



TENSORES DE LONA
CURTAIN TENSIONER

CURTAIN ACCESSORIES / PLANEN-ZUBEHÖR / ACCESORIOS DE LONAS

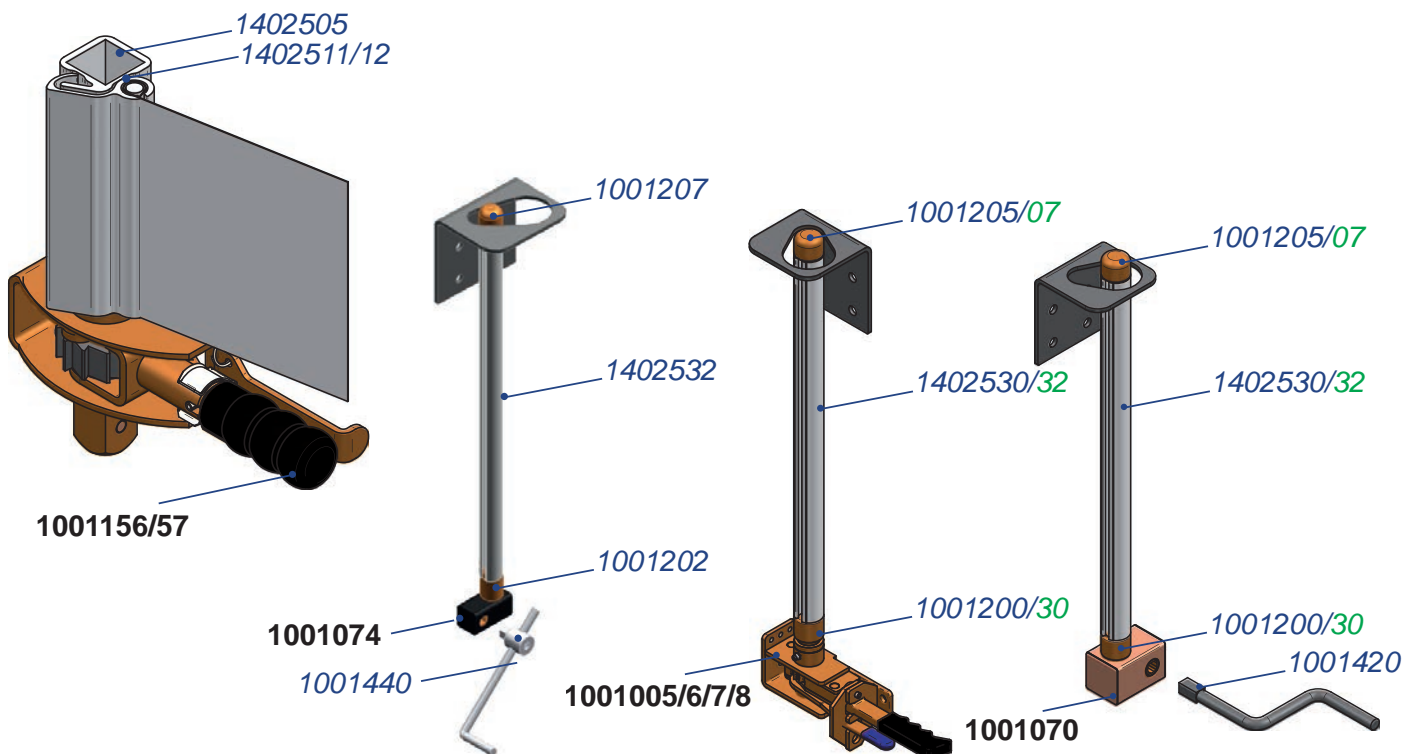
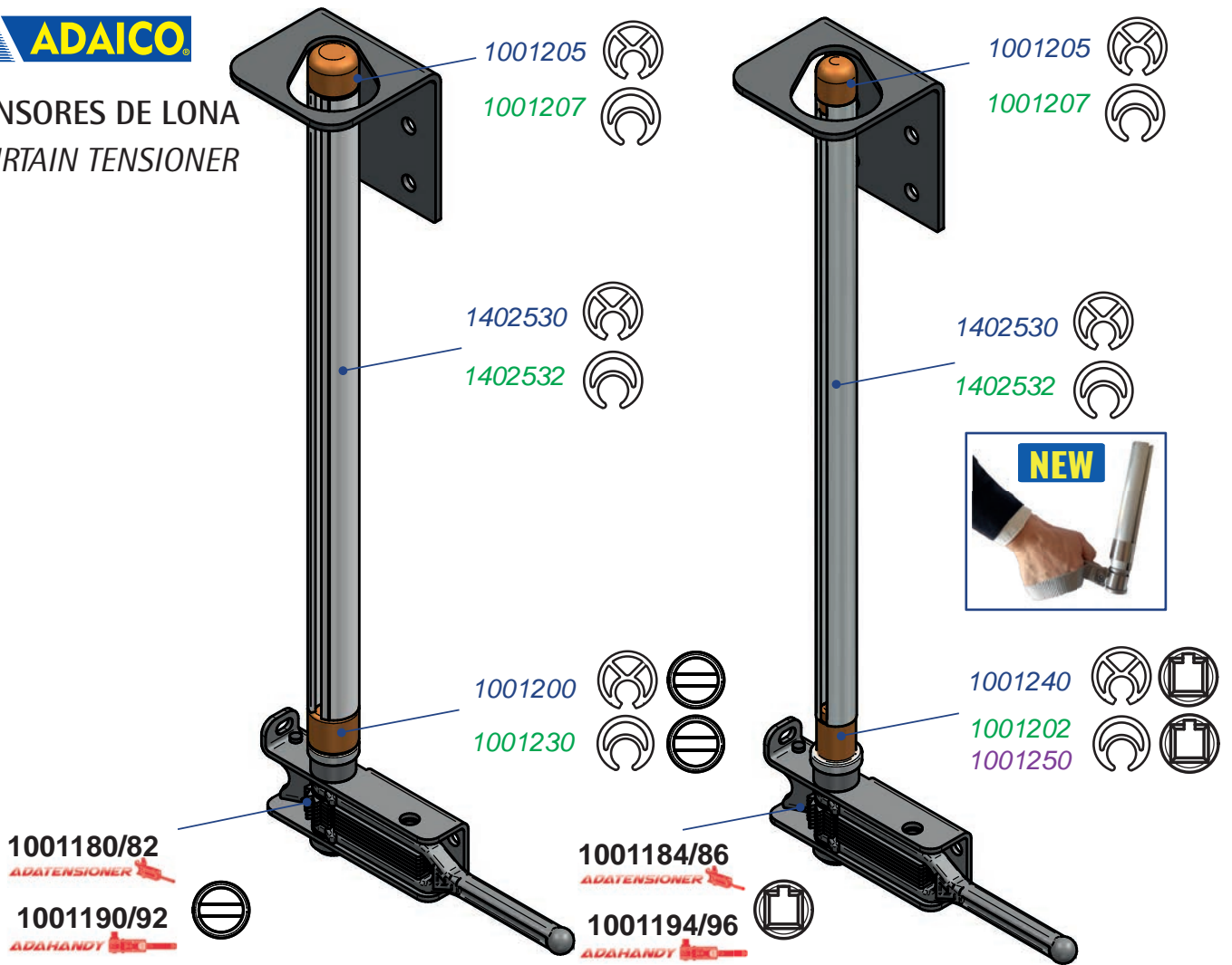

Aluminium Curtain Profile 3m.xØ27
 Panenspannprofil 3m.xØ27 Aluminium
 Perfil Lona 3m.xØ27 Aluminio

Ref	Kg	Mat	A	Lot
1402532	2.17		3m.	2

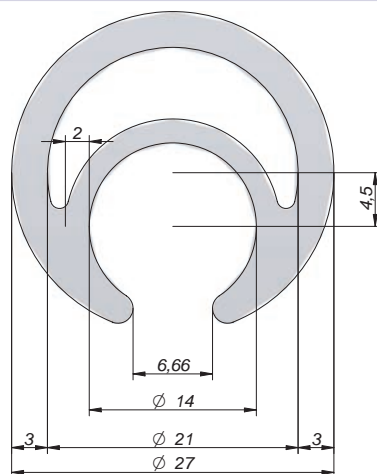
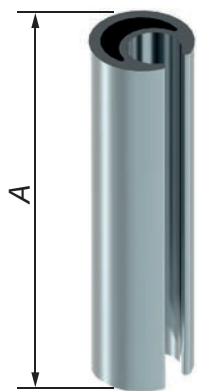

Adaptor Tension Bar 57xØ27 Up Half Moon
 Einsatz f. Planspannrohr 57xØ27 Oben Halbmond
 Adaptador Tensor 57xØ27 Superior Media Luna

Ref	Kg	Mat	Pos	Lot
1001207	0.15	Cu-Zn		2

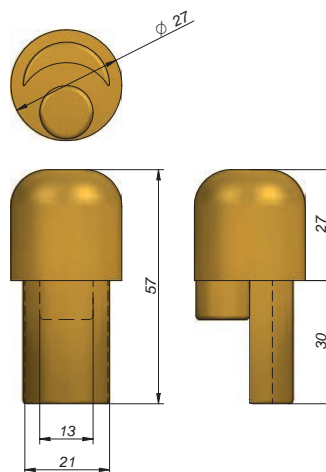

Adaptor Tension Bar 60xØ27 Down Half Moon
 Einsatz f. Planspannrohr 60xØ27 Unten Halbmond
 Adaptador Tensor 60xØ27 Inferior Media Luna

Ref	Kg	Mat	Pos	Lot
1001230	0.17	Cu-Zn		2

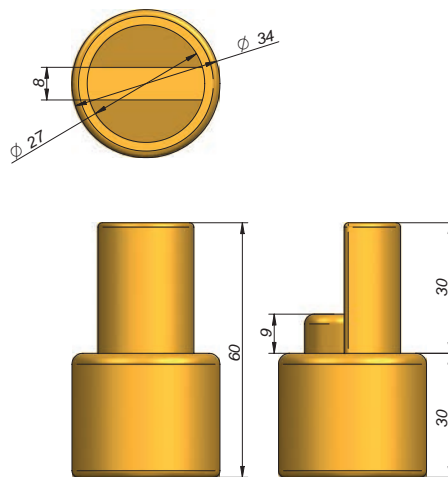
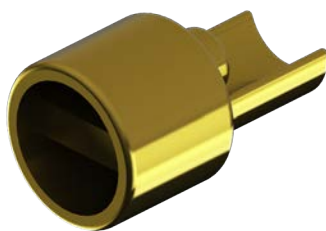

Adaptor Tension Bar 60xØ26 Down Half Moon
 Einsatz f. Planspannrohr 60xØ26 Unten Halbmond
 Adaptador Tensor 60xØ26 Inferior Media Luna

Ref	Kg	Mat	Pos	Lot
1001202	0.14	Cu-Zn		2

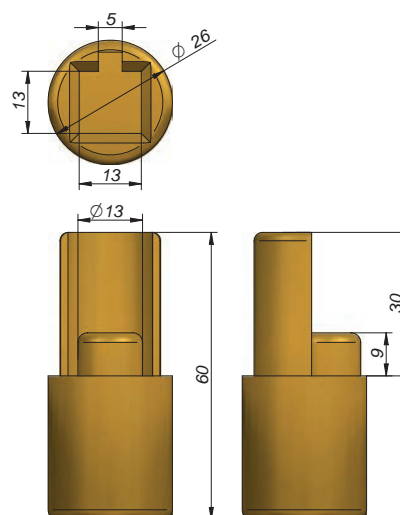
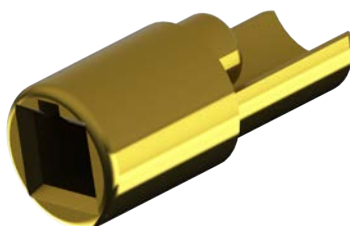

Aluminium Curtain Profile 3m.xØ34
 Panenspannprofil 3m.xØ34 Aluminium
 Perfil Lona 3m.xØ34 Aluminio

Ref	Kg	Mat	A	Lot
1402530	3.43		3m.	2

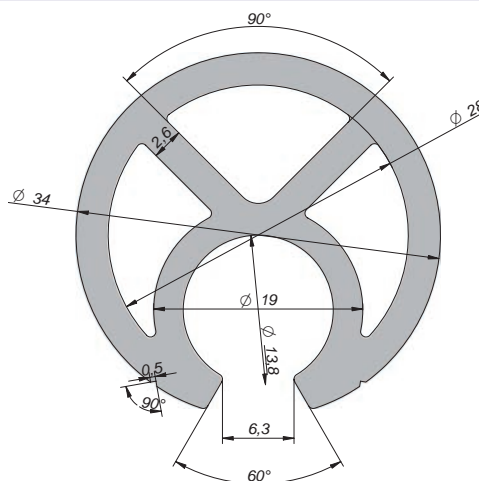
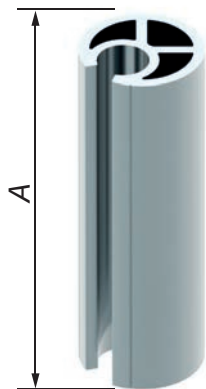

Adaptor Tension Bar 59xØ34 Down
 Einsatz f. Planspannrohr 59xØ34 Unten
 Adaptador Tensor 59xØ34 Inferior

Ref	Kg	Mat	Pos	Lot
1001200	0.19	Cu-Zn		2

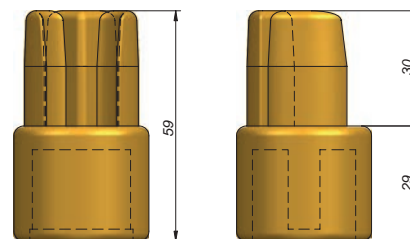
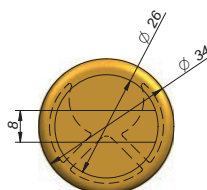

Adaptor Tension Bar 56xØ34 Up
 Einsatz f. Planspannrohr 56xØ34 Oben
 Adaptador Tensor 56xØ34 Superior

Ref	Kg	Mat	Pos	Lot
1001205	0.25	Cu-Zn		2

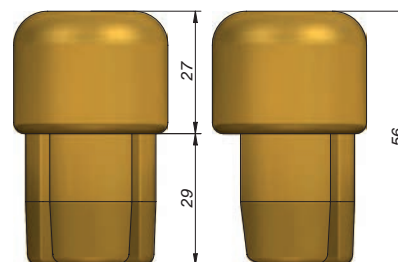
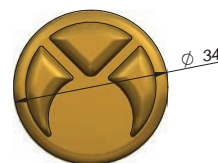



Reinforcing Ring
Anillo de Refuerzo

● Ref. 1001244

Made in stainless steel to protect the Adaptor tension in heavy tension force.
Fabricado en acero inoxidable para proteger el adaptador de tensor en caso de una gran fuerza de tensión.

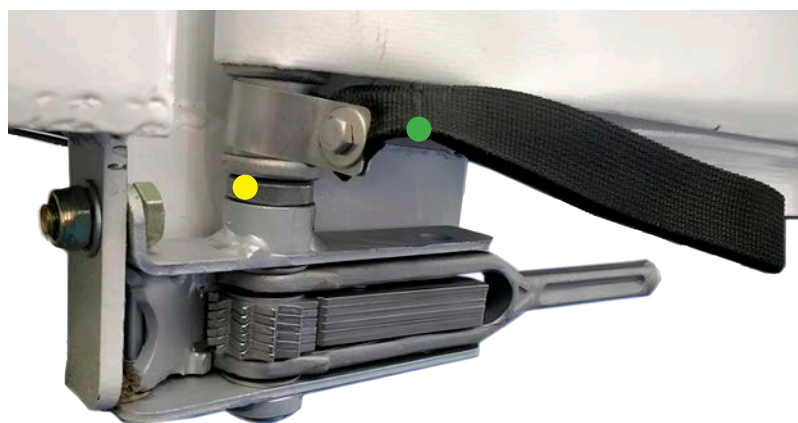

Nylon Handle Set
Kit de Sujeción en Nylon

● Ref. 1001242

Made in stainless steel to lift and remove the profile from the curtain tensioner.
Fabricado en acero inoxidable y nylon para levantar y quitar el perfil del tensor de lona.



Adaptor Tension Profile
Adaptador Tensor

● Ref. 1001240/50

Made in stainless steel to offer super anti-corrosion ability.
Fabricado en acero inoxidable para ofrecer una alta resistencia a la corrosión.



Adaptor Tension Bar 66,3xØ27,5 Down
Einsatz f. Planspanrohr 66,3xØ27,5 Unten
Adaptador Tensor 66,3xØ27,5 Inferior

Ref	Kg	Mat	Pack
1001240	0.8	INOX	4

NEW

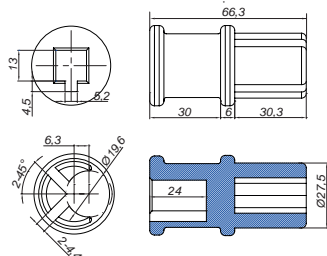

Adaptor Tension Bar 60xØ26 Down Half Moon
Einsatz f. Planspanrohr 60xØ26 Unten Halbmond
Adaptador Tensor 60xØ26 Inferior Media Luna

Ref	Kg	Mat	Pos	Lot	Pack
1001250	0.8	INOX	△▽	2	4

NEW

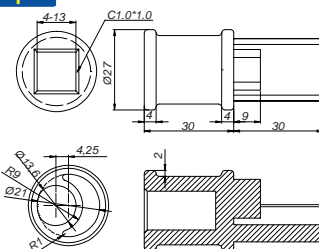

Nylon Handle Set for Adaptor Tension
Sangle Set Nylon für Einsatz
Kit Cinta Nylon Adaptador

Ref	Kg	Mat	Pack
1001242	0.04	Ny	4

Stainless Steel Components
Componentes en Acero Inoxidable

NEW

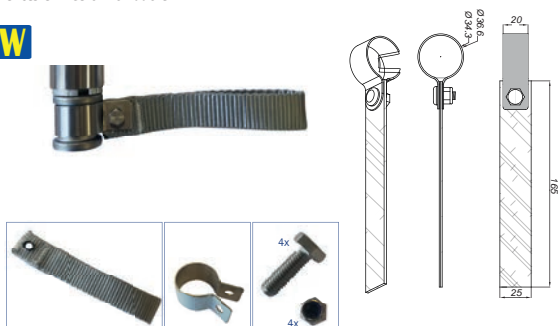

Reinforcing Ring for Adaptor Tension
Verstärkungsring für Einsatz
Anillo de Refuerzo Adaptador

Ref	Kg	Mat	Pack
1001244	0.04	INOX	4

NEW

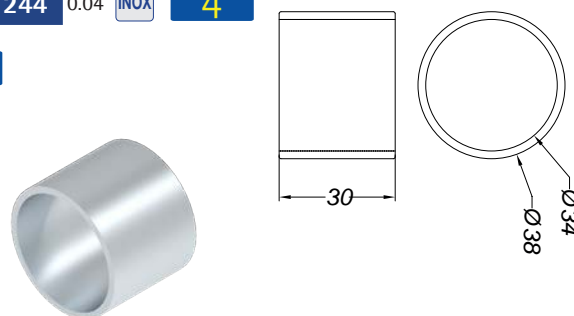

Forged Hook 80x56
 Geschmiedeter U-Haken 80x56
 Gancho de soldar Forjado 80x56

Ref	Kg	Mat	Lot
1501010	0.18	Forged	10

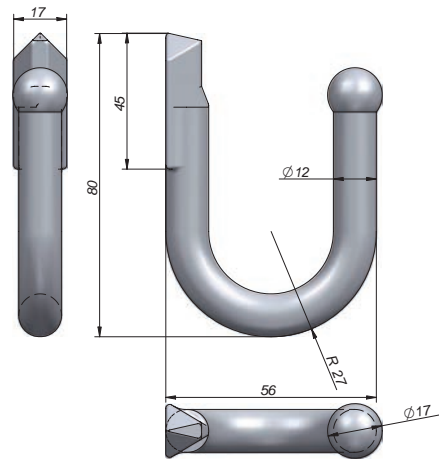
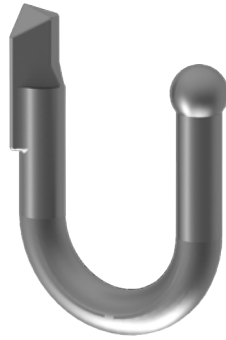

Forged Hook to weld 58x46
 Geschmiedeter U-Haken zum Anschweißen 58x46
 Gancho de soldar Forjado 58x46

Ref	Kg	Mat	Lot
1501015	0.1	Forged	10

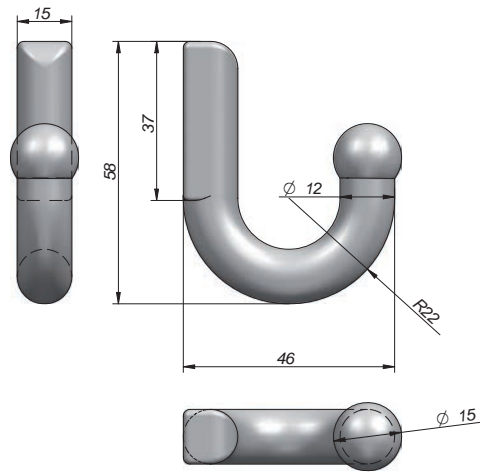

Pivot Hook Steel
 Zapfenhaken Stahl
 Pivote para Soldar Forjado

Ref	Kg	Mat	Lot
1501020	0.03	Forged	10

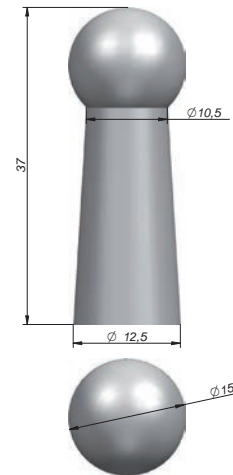
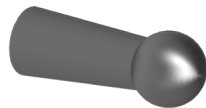

Flat Tendeur for Chain
 Geschmiedeter Pannketten-Haken Stahl
 Tensor de Cadena Plano

Ref	Kg	Mat	Lot
1501030	0.34	Forged	4

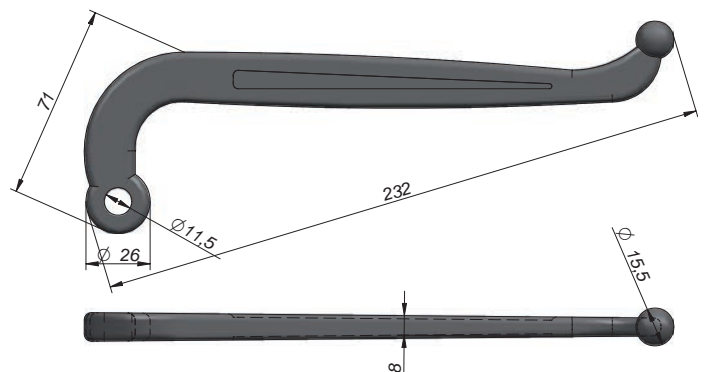

Vertical Hook Zinc Plated 40x15x19
 Planhaken Verzinkt 40x15x19
 Gancho Chapa Recto 40x15x19

Ref	Kg	Mat	Sup/Finish Acabado	Thickn. Espesor	Lot
1501038	0.01	STEEL	Zn	1.5	50

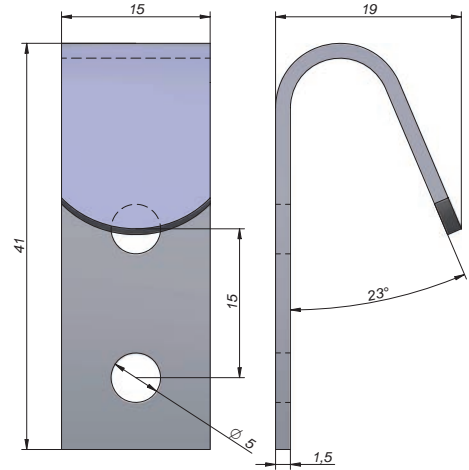

Vertical Hook Zinc Plated 70x20x24
 Planhaken Verzinkt 70x20x24
 Gancho Chapa Recto 70x20x24

Ref	Kg	Mat	Sup/Finish Acabado	Thickn. Espesor	Lot
1501040	0.03	STEEL	Zn	2	50

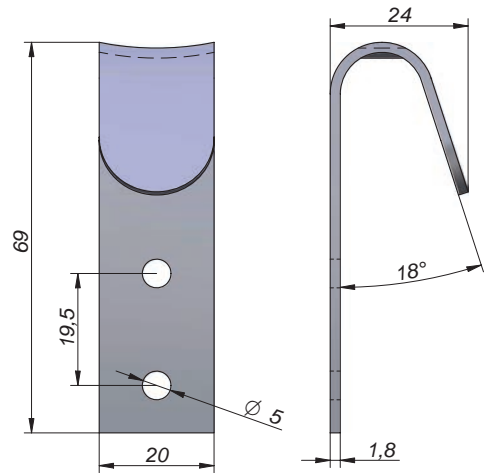
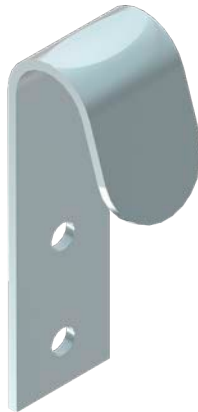

Steel Flat Hook
 Planhaken Verzinkt Stahl
 Gancho Chapa Corazón

Ref	Kg	Mat	Sup/Finish Acabado	Thickn. Espesor	Lot
1501045	0.03	STEEL	Zn	1.5	20

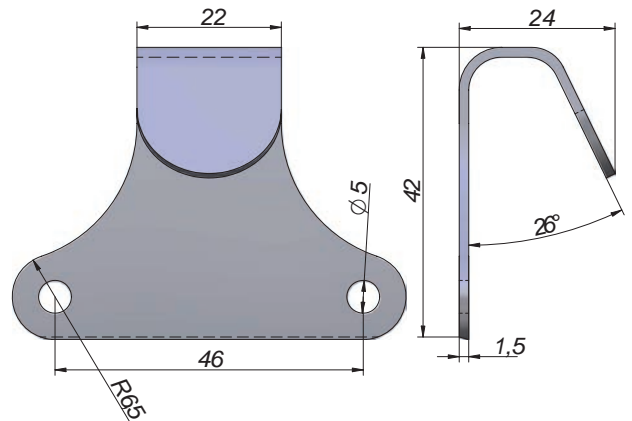
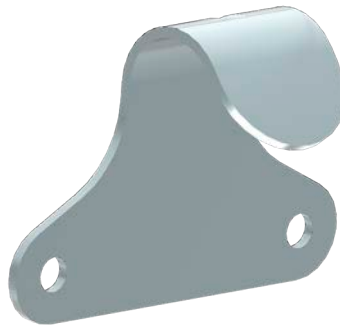

Cobra Plastic Hook
 Cobra Haken Kunststoff
 Gancho Cobra Plástico

Ref	Kg	Mat	Thickn. Espesor	Lot
1501055	0.02	PLASTIC	5	10

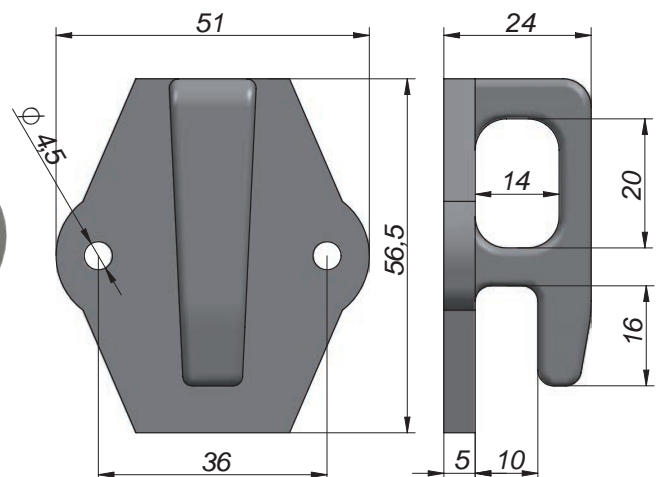

TIR Curtain Hook
Planhaken TIR, verzinkt
Puente Precinto TIR

Ref	Kg	Mat	Sup/Finish Acabado	Thickn. Espesor	Lot
1501110	0.03	STEEL	Zn	2	20

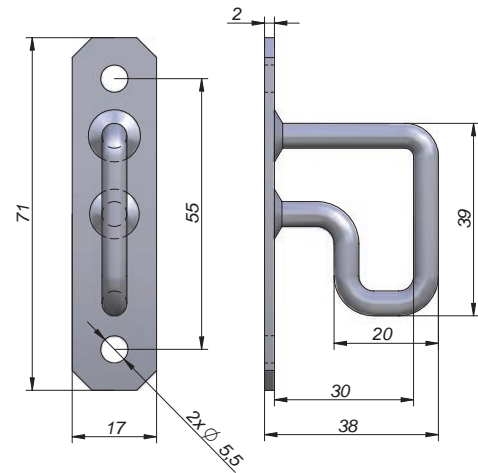

Curtain Hook Folding
Bügelkrampe klappbar, verzinkt
Precinto de anilla Abatible

Ref	Kg	Mat	Sup/Finish Acabado	Thickn. Espesor	Lot
1501120	0.06	STEEL	Zn	3	10

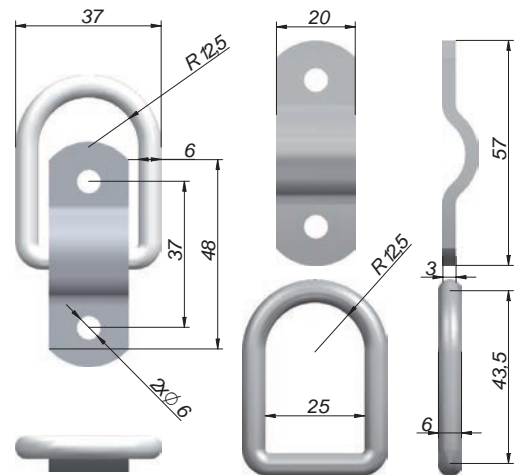

Folding Curtain Hook
Planen-Drehwirbel, verzinkt
Puente Precinto TIR Abatible

Ref	Kg	Mat	Sup/Finish Acabado	Thickn. Espesor	Lot
1501125	0.05	STEEL	Zn	2	10

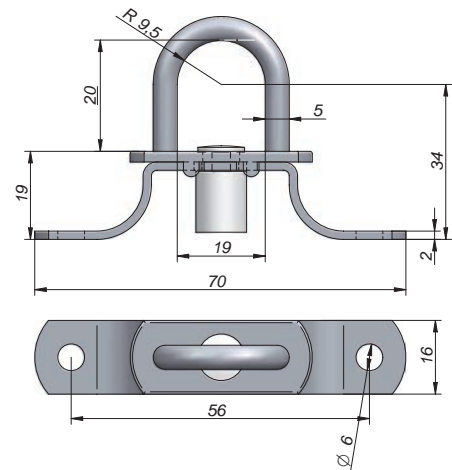

Revolving Folding Curtain Hook
Planen-Drehwirbel, klappbar, verzinkt
Puente Precinto TIR Abatible Giratorio

Ref	Kg	Mat	Sup/Finish Acabado	Thickn. Espesor	Lot
1501128	0.04	STEEL	Zn	2	50

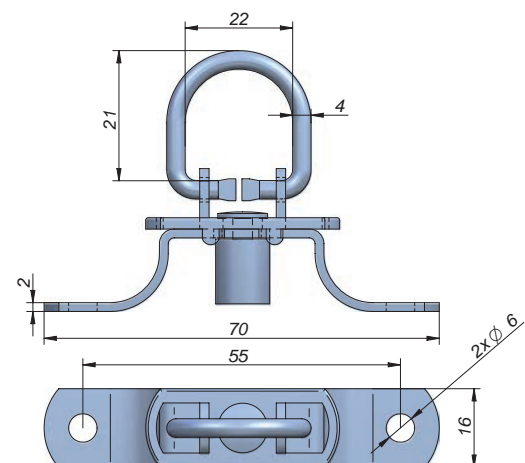



CURTAIN HOOKS / PLANENHAKEN / GANCHOS Y PUENTES PRECINTO

CURTAIN ACCESSORIES / PLANEN-ZUBEHÖR / ACCESORIOS DE LONAS

TIR Cable Roll
TIR-Kabel Rolle
Rollo Cable TIR

Ref	Kg	Mat	A	Ø	Lot
0901158	1.14	 PVC	21 m.	5.8	1
0901159	1.4	 PVC	26 m.	5.8	1
0901160	1.55	 PVC	33,5 m.	5.8	1
0901164	1.62	 PVC	40 m.	5.8	1
0901166	2.1	 PVC	46 m.	5.8	1



TIR Cable Roll without cap 100m.
TIR Kabelrolle ohne Endstück 100m.
Rollo Cable TIR sin terminal 100 m.

Ref	Kg	Mat	A	Ø	Lot
0901168	4.6	 PVC	100 m.	5.8	1



TIR Cable Roll
TIR Kabel-Endstück
Terminal Rollo Cable TIR

Ref	Kg	Pack
0901171	0.1	10

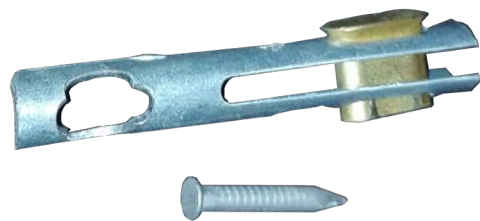

Stainless Steel Buckle (Push) w/Stainless Steel Hook
 Planen-Spanner Edelstahl (Push) m/Flachhaken Edelstahl
 Hebilla Completa Inox Pulsador c/Gancho Inox

Ref	Kg	Mat	A	Lot
0901026	0.46	INOX	700	5
0901027	0.46	INOX	900	1

Stainless Steel Hook
 Gancho Inox

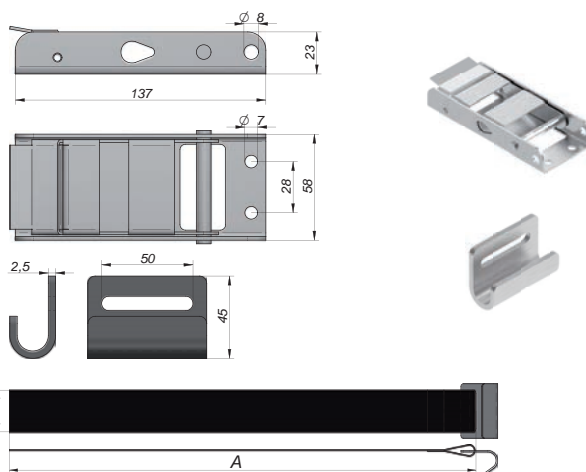

Stainless Steel Buckle (Plastic Push) Stainless Steel Hook
 Planen-Spanner Edelstahl (Plastik-Push) m/Flachhaken Edelstahl
 Hebilla Completa Inox Pulsador Plástico c/Gancho Inox

Ref	Kg	Mat	A	Lot
0901031	0.46	INOX	900	1
0901032	0.4	INOX	670	5

Stainless Steel Hook
 Gancho Inox

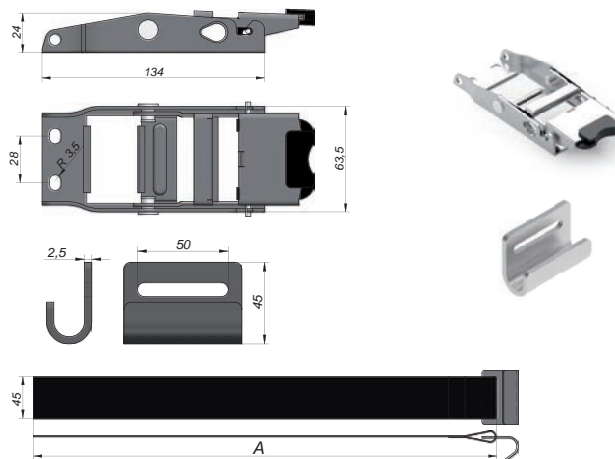

Stainless Steel Buckle (Plastic Push) w/Zinc Plated Hook
 Planen-Spanner Edelstahl (Plastik-Push) m/Drahthaken Verzinkt
 Hebilla Completa Inox Pulsador Plástico c/Gancho Cincado

Ref	Kg	Mat	A	Lot
0901033	0.46	INOX	900	1

Zinc Plated Hook
 Gancho varilla cincado

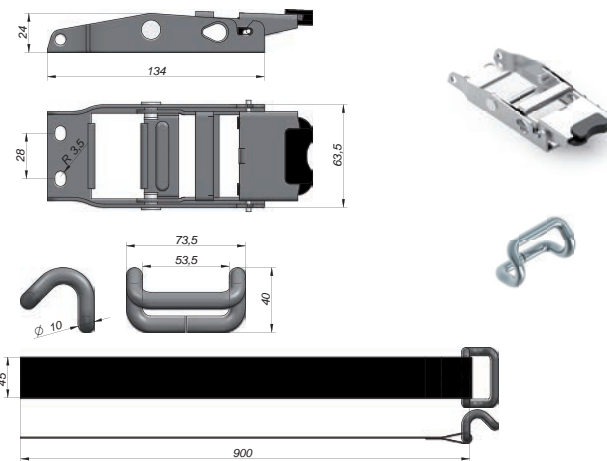

Stainless Steel Buckle "Over/Center" Stainless Steel Hook
 Overcenter-Spanner Komplett Edelstahl m/Flachhaken Edelstahl
 Hebilla Completa Inox "Over/Center" c/Gancho Inox

Ref	Kg	Mat	A	Lot
0901041	0.388	INOX	900	1
0901042	0.275	INOX	670	1

Stainless Steel Hook
 Gancho Inox

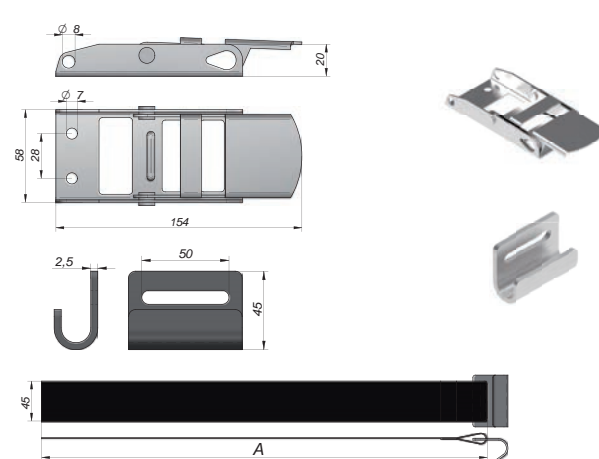



BUCKLES / PLANEN-SPANNER / HEBILLAS

CURTAIN ACCESSORIES / PLANEN-ZUBEHÖR / ACCESORIOS DE LONAS

Stainless Steel Buckle "Over/Center" Zinc Plated Steel Hook
Overcenter-Spanner Komplett Edelstahl m/Flachhaken Verzinkt
Hebilla Completa Inox "Over/Center" c/Gancho Cincado

Ref	Kg	Mat	A	Lot
0901045	0.3	INOX	900	1

Zinc Plated Steel Hook
Gancho Acero Cincado

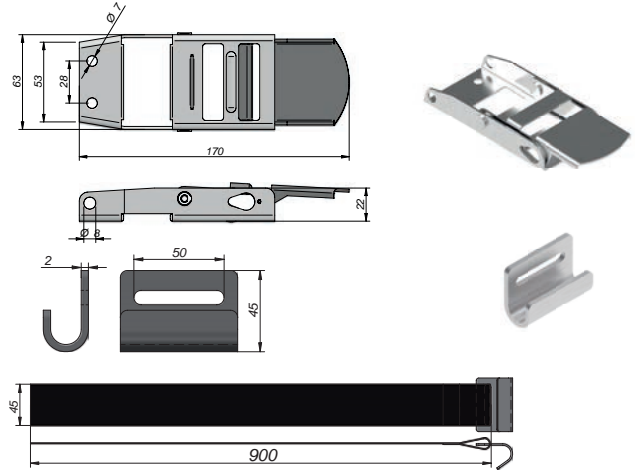

Stainless Steel Buckle "Over/Center" w/Zinc Plated Hook
Overcenter-Spanner Komplett Edelstahl m/Drahhaken Verzinkt
Hebilla Completa Inox "Over/Center" c/Gancho Cincado

Ref	Kg	Mat	Lot
0901043	0.46	INOX	1

Zinc Plated Hook
Gancho varilla cincado

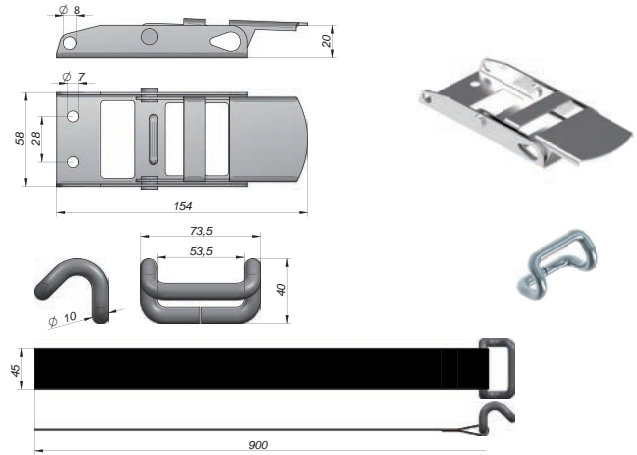

Stainless Steel Buckle (Plastic Push), 3 nerves hook
Planen-Spanner Edelstahl (Plastik-Push) mit 3 Nerven Haken
Hebilla Completa Inox Pulsador Plástico c/Gancho 3 Nervios

Ref	Kg	Mat	A	Lot
0901046	0.38	INOX	900	1

3 nerves Hook Stainless Steel
Gancho Acero Inoxidable 3 Nervios

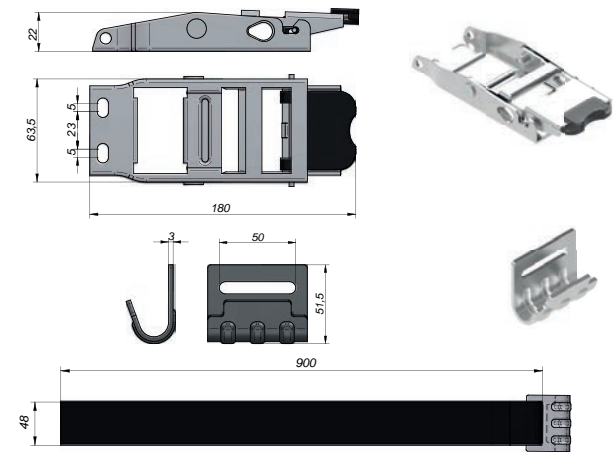

Strap with 3 nerves Hook Stainless Steel
Ersatzgurtband - 3 Nerven Haken Edelstahl
Cinta de hebilla c/Gancho 3 Nervios Inox

Ref	Kg	Mat	A	Pack
0901118	1.3	INOX	900	10
0901117	1.3	INOX	700	10

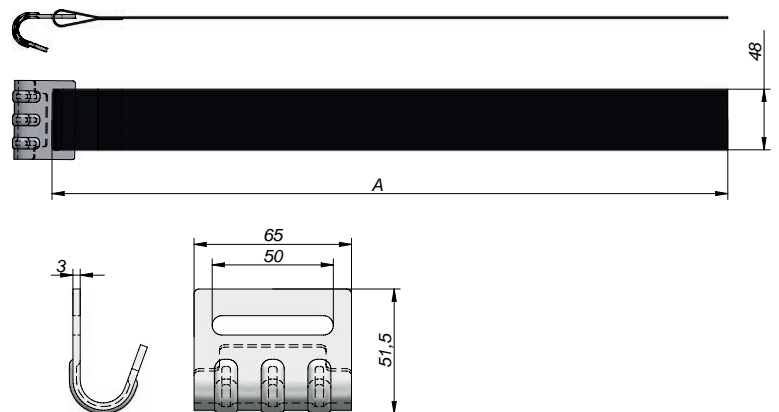

Strap with Closed Buckle Hook
Ersatzgurtband - Flachhaken Edelstahl
Cinta con Gancho Cerrado

Ref	Kg	Mat	Lot
0901119	0.2	INOX	10

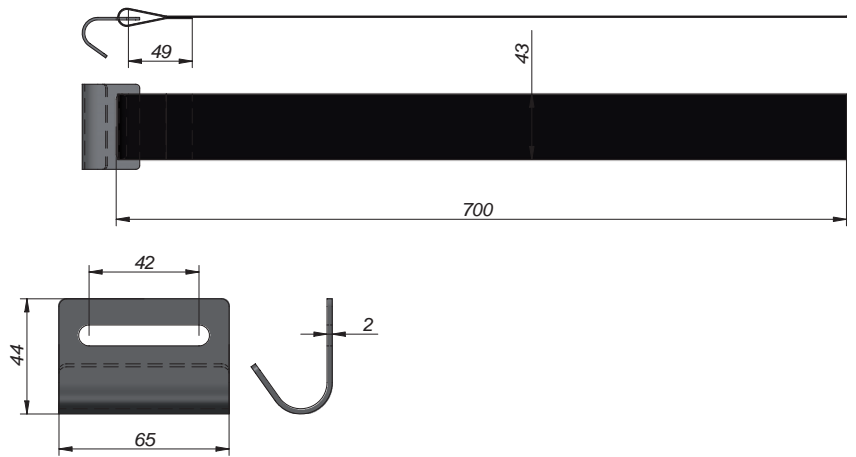

Strap with Zinc Plated Buckle Hook
Ersatzgurtband - Drahhaken Verzinkt
Cinta con Gancho Cincado

Ref	Kg	Mat	Sup/Finish Acabado	Lot
0901120	0.2	STEEL	Zn	10

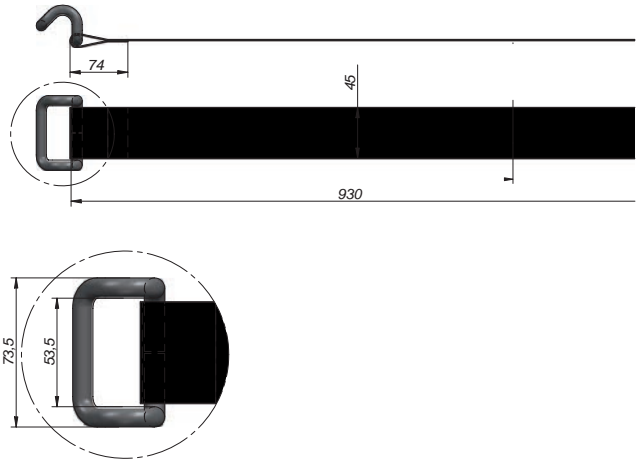

Buckle Cover Stainless Steel 2 Bolts/Nut
Schnallenverbinder, Edelstahl, 2 Schrauben/Muttern
Tapa Hebilla Inox 2 Tornillos/Tuerca

Ref	Kg	Mat	Metric	Pack
0901255	0.25	INOX	M6	10

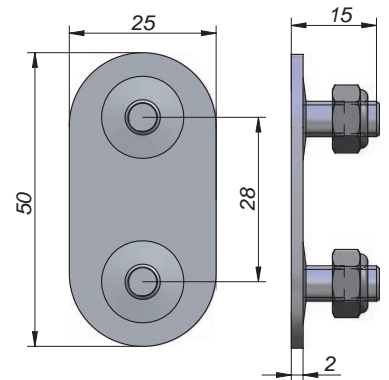

Buckle Cover Plastic 2 Bolts/Nut
Schnallenverbinder, Kunststoff, 2 Schrauben/Muttern
Tapa Hebilla Plástico Negra 2 Tornillos/Tuerca

Ref	Kg	Mat	Metric	Pack
0901251	0.2	INOX	M6	10

Stainless steel screw
Tornillo en acero inoxidable

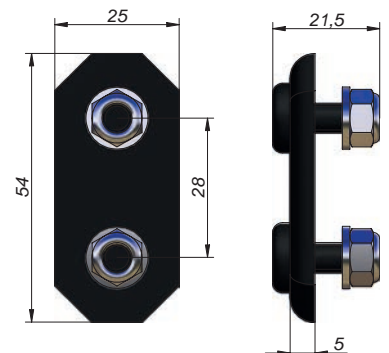



BUCKLES / PLANEN-SPANNER / HEBILLAS

CURTAIN ACCESSORIES / PLANEN-ZUBEHÖR / ACCESORIOS DE LONAS

Steel Plate "Outfolding"
Ausfalt-Stahlband
Muelle "Outfolding"

Ref	Kg	Mat	Pack
0902061	0.1	INOX	10

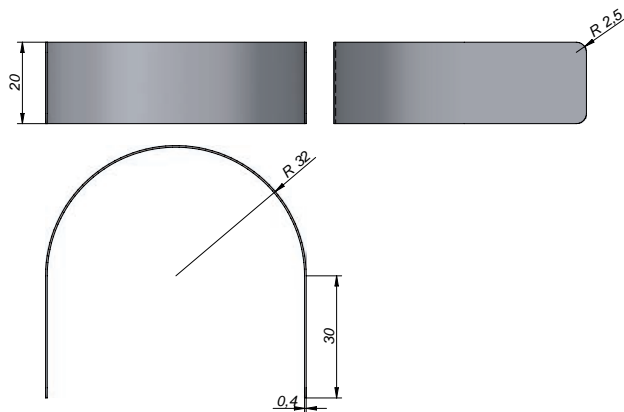

PP "Outfolding" ADA-SLIDER
"Ausfalt"-PVC-Band ADA-SLIDER
Plástico "Outfolding" ADA-SLIDER

Ref	Kg	Mat	A	Lot
0902064	0.06	PP	2 m.	2

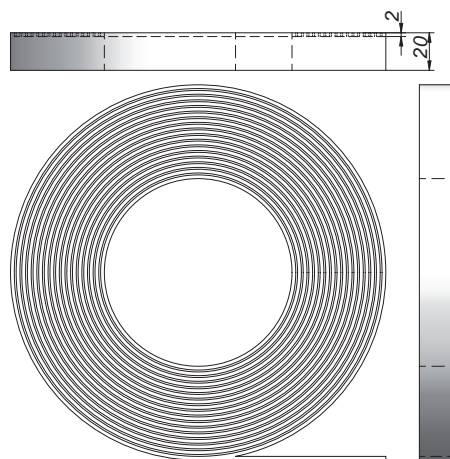

Weldable Tape Roll 100m.x49mm. 1.300Kg.
Schweißbares Gurtband 100m.x49mm. 1.300Kg.
Cinta soldable Rollo 100m.x49mm. 1.300Kg.

Ref	Kg	Mat	Col	Thickn. Espesor	Lot
0901172	5.2	GRP	Grey	1±0,3 mm.	1
0901174 NEW	5.2	GRP	Black	1±0,3 mm.	1
0901176	5.2	GRP	White	1±0,3 mm.	1

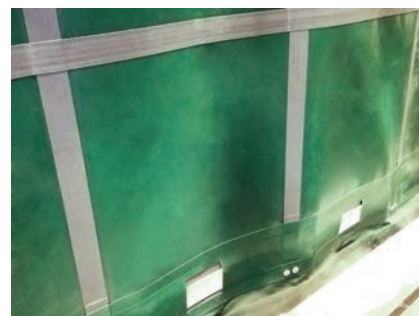

100% Polyester with PVC Coating | Breaking Load: 1.300 Kg. (12750N) |
Temperature Range: -20bis +60°C
100% Poliéster con recubrimiento PVC | Carga Rotura: 1.300 Kg. (12750N) |
Rango Temperatura: -20bis +60°C

Vandal-Proof Weldable Tape Roll 130m.x23mm.
Antivandalismusband 130m.x23mm.
Cinta Soldable Antivandálica, Rollo 130m.x23mm.

Ref	Kg	Mat	Col	Lot
0901178	3.6	PVC	Grey	1

Metallic inner wire Ø1,5mm.
Cable interior metálico Ø1,5 mm.



Cierres

Locks

Fermetures

Verschlüsse

Fechos

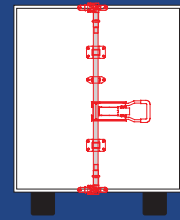

Cierres de Cartola

Sideboard Lock

Fermeture de Ridelle

Seitenwandverschlüsse

Fechos de Taipais



pag. 232

Cierres y Uñas

Locks and Clamps

Fermetures et Gâches

Verschlüsse / Klemmen

Fechos e Unhas



pag. 233-241

Tiradores de Muelle

Runner Clamps

Vérous à Ressort

Federriegel

Puxador de Mola



pag. 242-243

Cierres de Cajón

Box Locks

Fermetures Tiroirs

Kastenverschlüsse

Fechos de Caixas

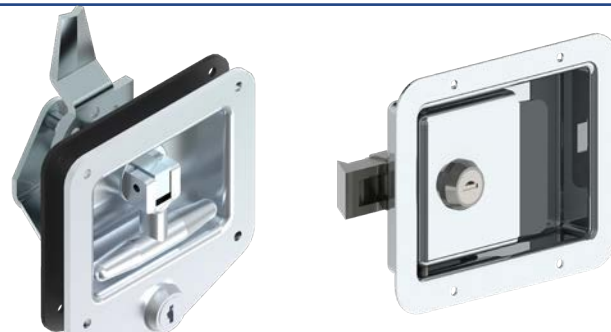

pag. 244-246

Cierres Falleba

Trailer Door Gear

Crémones

Drehstangenverschlüsse

Fechos de Porta

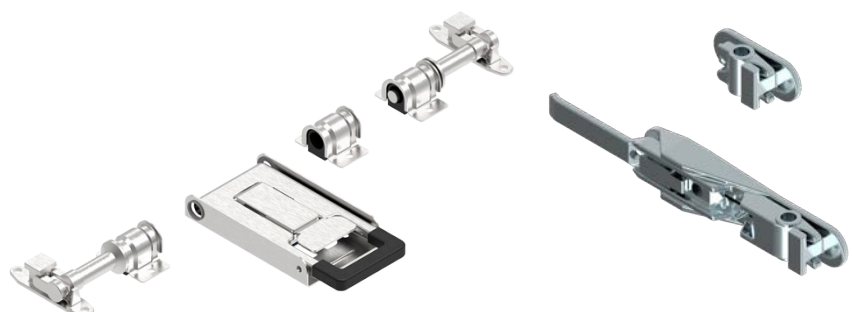

pag. 247-252



SIDEBORD LOCK / SEITENWANDVERSCHLÜSSE / CIERRES DE CARTOLA

LOCKS / VERSCHLÜSSE / CIERRES

Sideboard Lock
Bordwand-Langwegverschluss
Cierre Lateral Aluminio Cartola

Ref	Kg	Mat	Sup/Finish Acabado	Pos	A	B	C	Lock Type Cierre	Lot
1201016	1.15		Anod		415	324			1
1201018	1.15		Anod		415	324			1
1201020	1.47		Anod		615	483			1
1201022	1.47		Anod		615	483			1
1201030	1.57		Anod		815	677			1
1201032	1.57		Anod		815	677			1
1201040	1.89		Anod		1015	471	805		1
1201042	1.89		Anod		1015	471	805		1

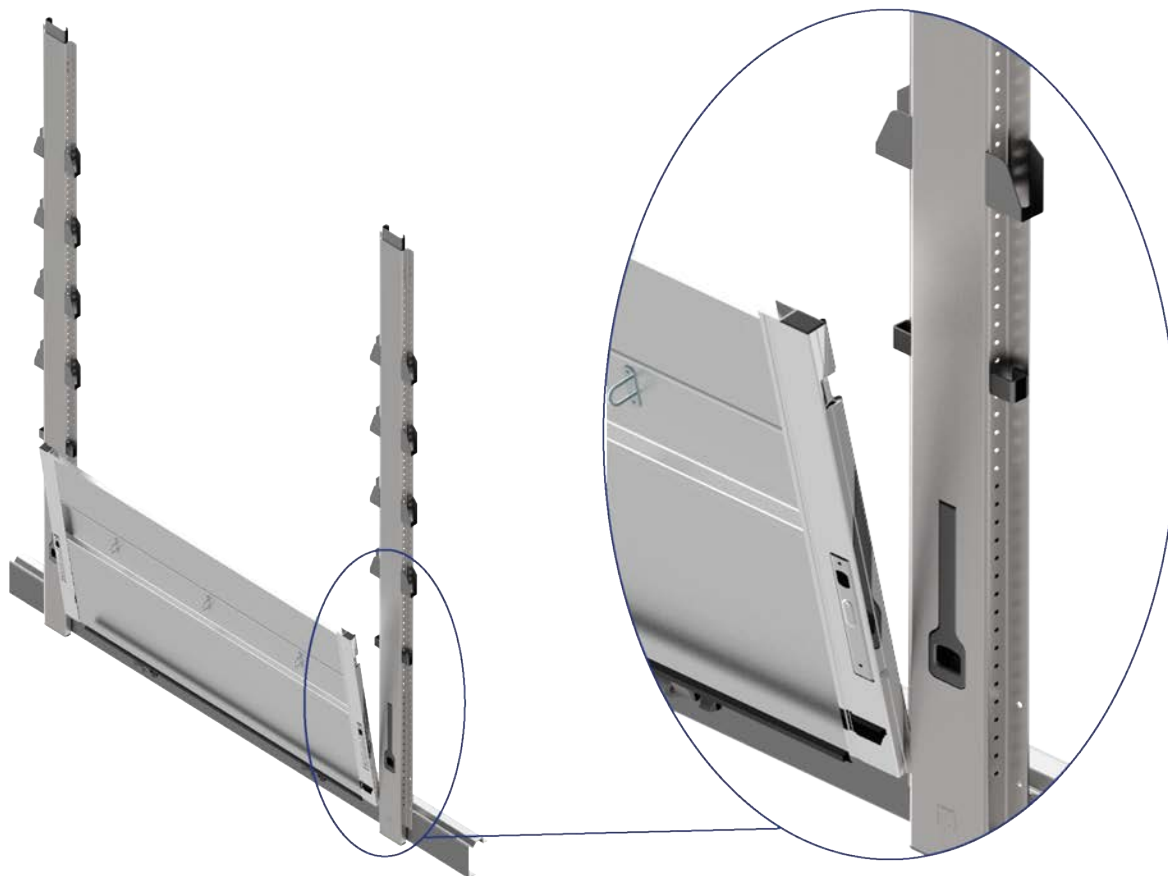
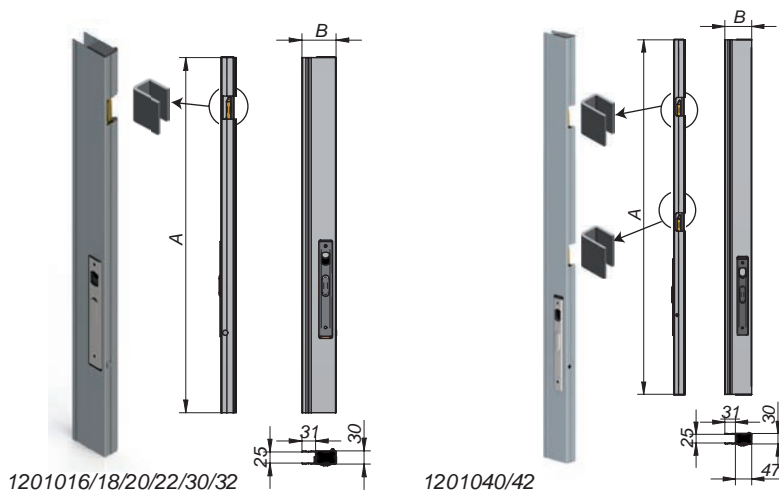

Sideboard Lock Pocket 23x32
Rungentasche für Langwegverschluss 23x32
Uña Cierre Cartola 23x32

Ref	Kg	Mat	Lot
1204056	0.05	STEEL	10

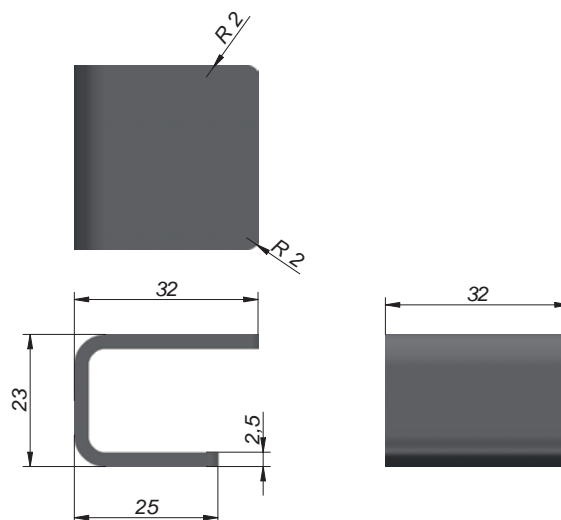



German Lock 77x64 Zinc Plated
 Verschluss 77x64 Verzinkt
 Cierre Alemán 77x64 Cincado

Ref	Kg	Mat	Sup/Finish Acabado	Lock Type Cierre	Lot
1201210	0.37	Forged	Zn	T6	4

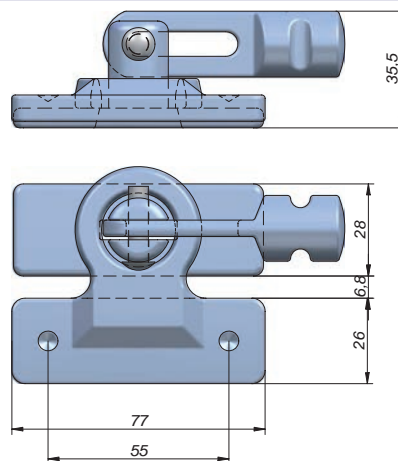
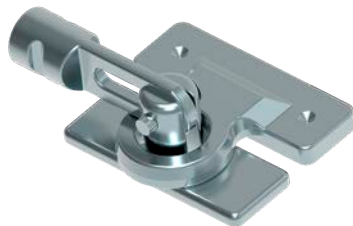

German Lock 124x93 Zinc Plated
 Verschluss 124x93 Verzinkt
 Cierre Alemán 124x93 Cincado

Ref	Kg	Mat	Sup/Finish Acabado	Lock Type Cierre	Lot
1201212	0.95	Forged	Zn	T5	2

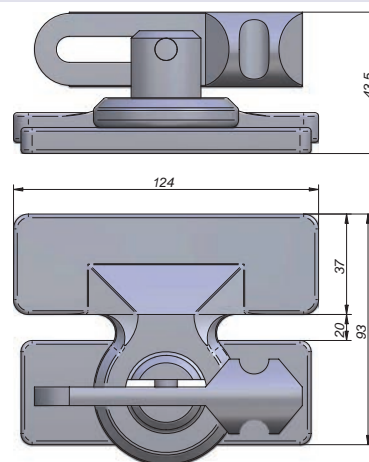
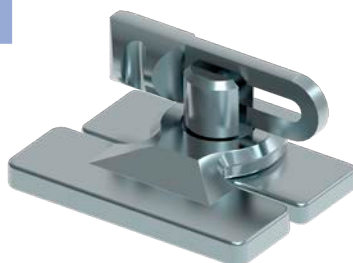

Forged Spring Lock
 Geschmiedeter Federriegelverschluss
 Cierre Muelle Forjado

Ref	Kg	Mat	A	B	C	D	E	Lock Type Cierre	Lot
1201215	1.15	Forged	285	180	20	15	33	T9	2

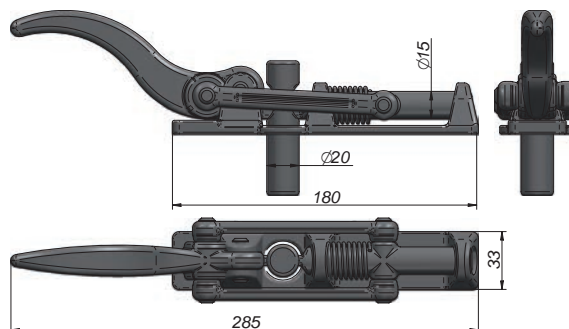
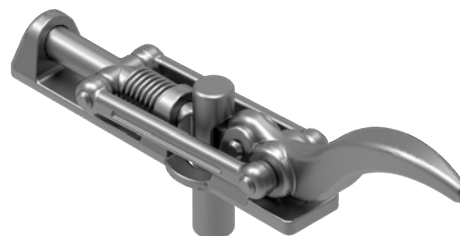



LOCKS AND CLAMPS / VERSCHLÜSSE / CIERRES Y UÑAS

LOCKS / VERSCHLÜSSE / CIERRES

Forged Zinc Plated Lock 146x42
 Verschluss Geschmiedet-Verzinkt 146x42
 Cierre Catalán Forjado Cincado 146x42

Ref	Kg	Mat	Sup/Finish Acabado	Lock Type Cierre	Lot
1201225	0.35	Forged	Zn	C4	2

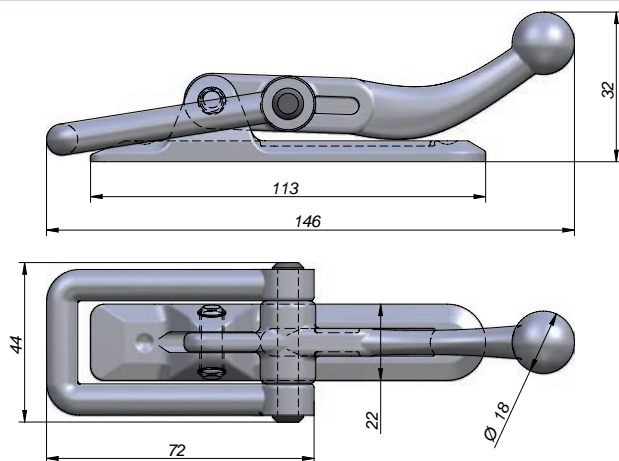

Fix Pocket U-4
 Verschluss-Gegenhalter U-4
 Uña Fija U-4

Ref	Kg	Mat	Sup/Finish Acabado	Lock Type Cierre	Lot
1204015	0.1	Forged	Zn	C4	2

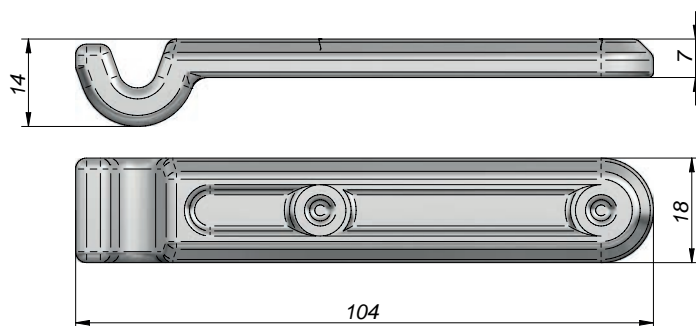

Forged Zinc Plated Lock 190x52
 Verschluss Geschmiedet-Verzinkt 190x52
 Cierre Catalán Forjado Cincado 190x52

Ref	Kg	Mat	Sup/Finish Acabado	Lock Type Cierre	Lot
1201220	0.51	Forged	Zn	C3	2

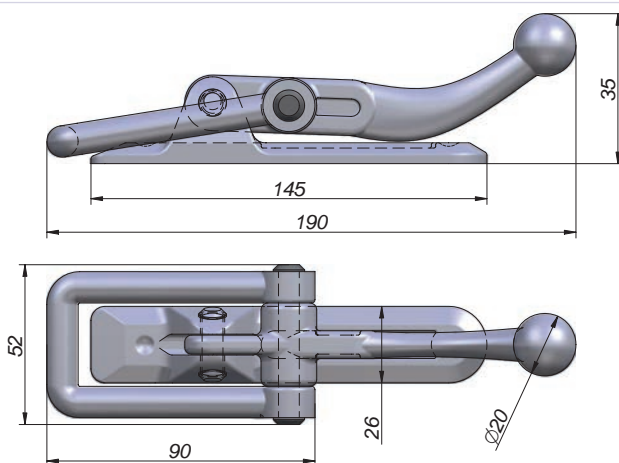

Fix Pocket U-3
 Verschluss-Gegenhalter U-3
 Uña Fija U-3

Ref	Kg	Mat	Sup/Finish Acabado	Lock Type Cierre	Lot
1204017	0.17	Forged	Zn	C3	2

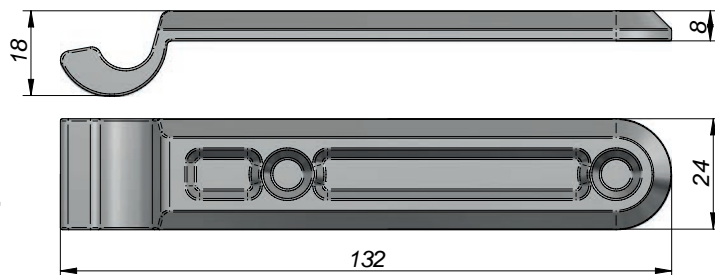

Lock with Safety Device Zinc Plated Forged
 Verschluss Geschmiedet mit Sicherung - Verzinkt
 Cierre c/Seguro Forjado Cincado

Ref	Kg	Mat	Sup/Finish Acabado	Lock Type Cierre	Lot
1201235	1.05	Forged	Zn	C8	2

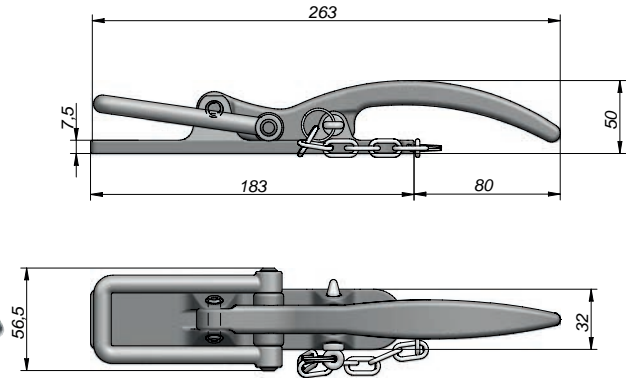

Zinc Plated Articulated Pocket 72x54
 Verschluss-Gegenhalter, klappbar, Verzinkt 72x54
 Uña Articulada 72x54 Cincada

Ref	Kg	Mat	Sup/Finish Acabado	Thickn. Espesor	Lock Type Cierre	Lot
1204030	0.26	Forged	Zn	10	C8	2

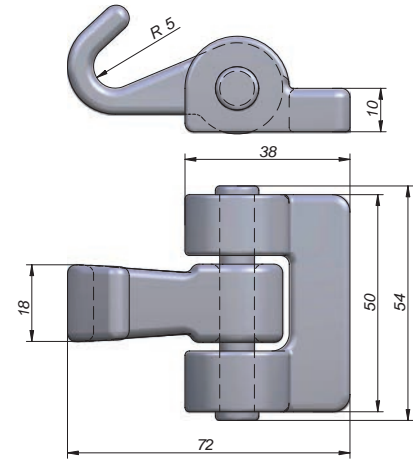

Lock with Safety Device Zinc Plated Steel
 Verschluss Geschmiedet mit Sicherung - Verzinkt
 Cierre c/Seguro Acero Cincado

Ref	Kg	Mat	Sup/Finish Acabado	Lock Type Cierre	Lot
1201240	0.62	STEEL	Zn	C9	2

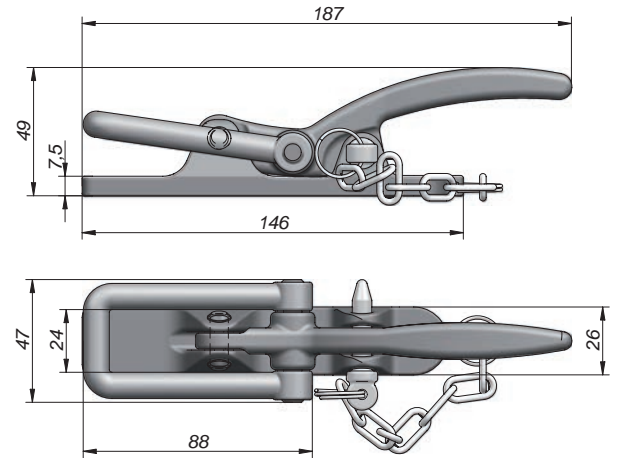

Zinc Plated Articulated Pocket 79x72
 Verschluss-Gegenhalter, klappbar, Verzinkt 79x72
 Uña Articulada 79x72 Cincada

Ref	Kg	Mat	Sup/Finish Acabado	Thickn. Espesor	Lock Type Cierre	Lot
1204040	0.23	Forged	Zn	6.5	C9	2

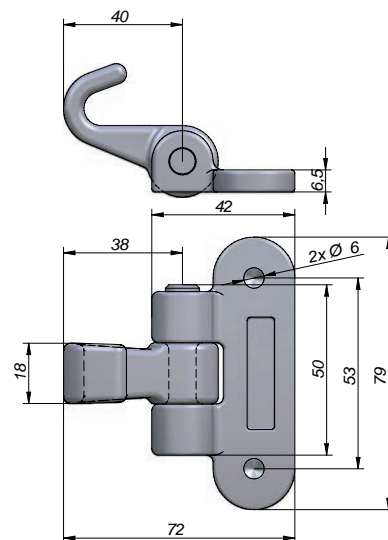

Zinc Plated Lock with padlock
 Kastenverschluss Verzinkt mit Schloss
 Cierre Remolque Chapa Cincado c/Candado

Ref	Kg	Mat	Sup/Finish Acabado	Lot
1201309	0.35	STEEL	Zn	1

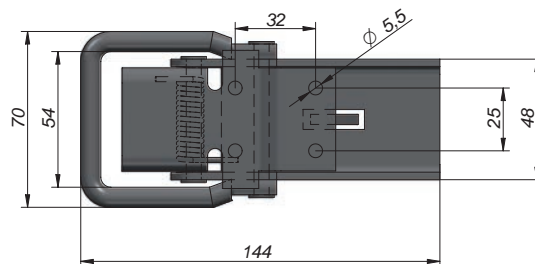
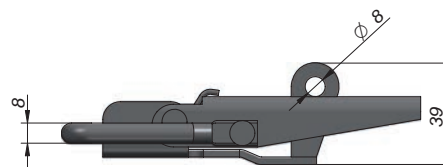

Zinc Plated Lock 145x68
 Kastenverschluss Verzinkt 145x68
 Cierre Remolque Chapa Cincado 145x68

Ref	Kg	Mat	Sup/Finish Acabado	Lot
1201310	0.33	STEEL	Zn	4

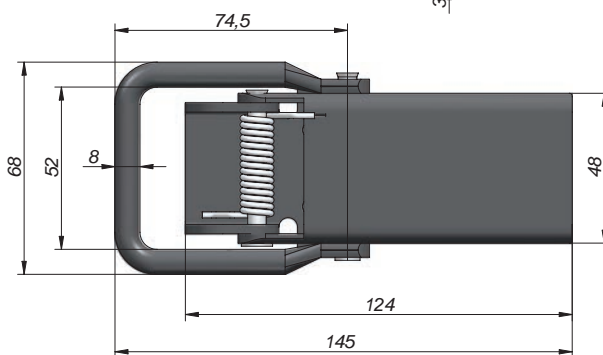
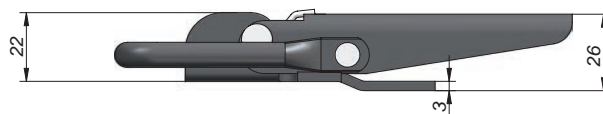

Zinc Plated Pocket Fix 57x40
 Verschluss-Gegenhalter 57x40 Verzinkt
 Uña Fija 57x40 Cincada

Ref	Kg	Mat	Sup/Finish Acabado	Thickn. Espesor	Lot
1204050	0.08	STEEL	Zn	4	4

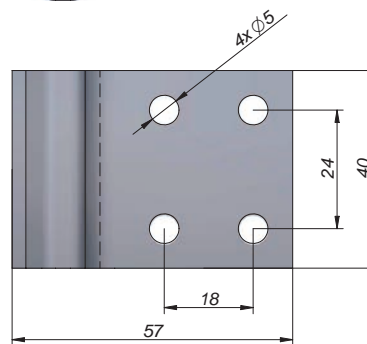
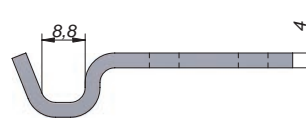

Zinc Plated Lock 95x45
 Kastenverschluss Verzinkt 95x45
 Cierre Remolque Chapa Cincado 95x45

Ref	Kg	Mat	Sup/Finish Acabado	Lot
1201311	0.11	STEEL	Zn	2

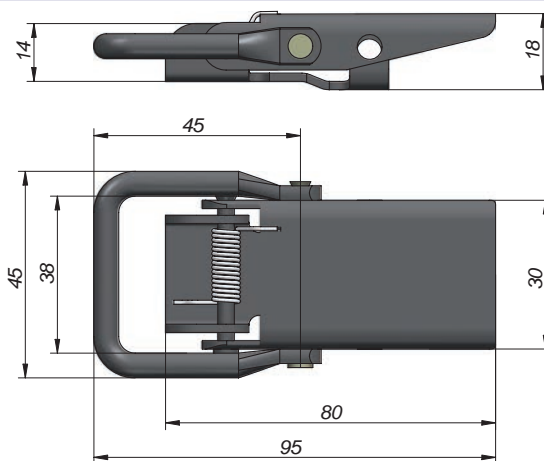

Zinc Plated Fix Pocket 83x25
 Verschluss-Gegenhalter 83x25 Verzinkt
 Uña Fija 83x25 Cincada

Ref	Kg	Mat	Sup/Finish Acabado	Thickn. Espesor	Lot
1204052	0.06	STEEL	Zn	3	5

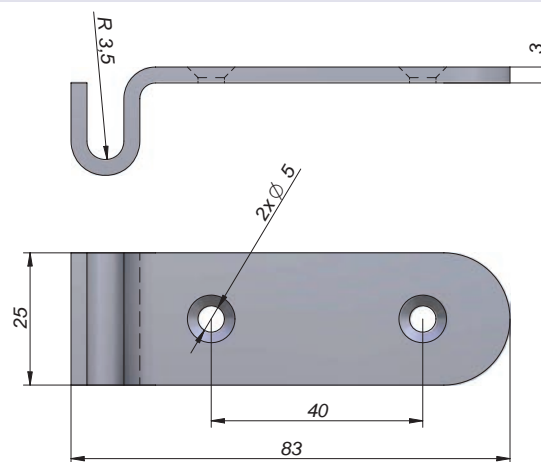

Zinc Plated Fix Pocket 88x25
 Verschluss-Gegenhalter 88x25 Verzinkt
 Uña Fija 88x25 Cincada

Ref	Kg	Mat	Sup/Finish Acabado	Thickn. Espesor	Lot
1204054	0.05	STEEL	Zn	3	5

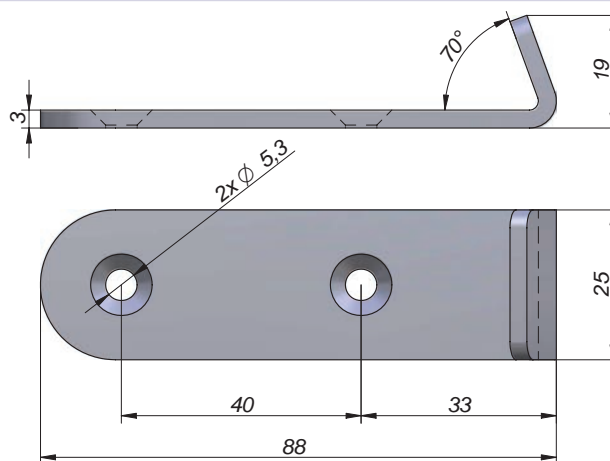

Zinc Plated Side Wall Lock
 Aufbau-Bordwandverschluss Verzinkt
 Cierre Cartola Cincado

Ref	Kg	Mat	Sup/Finish Acabado	Lot
1201342	1.11	STEEL	Zn	1

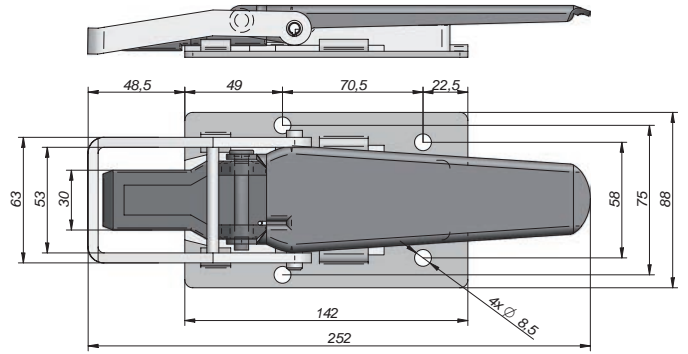

Pocket Fix (Side Wall Lock) Steel
 Rungentasche f. Aufbau-Bordwandverschluss, Stahl
 Uña Fija (Cierre Cartolas) Acero

Ref	Kg	Mat	Thickn. Espesor	Lot
1204012	0.06	STEEL	5	2

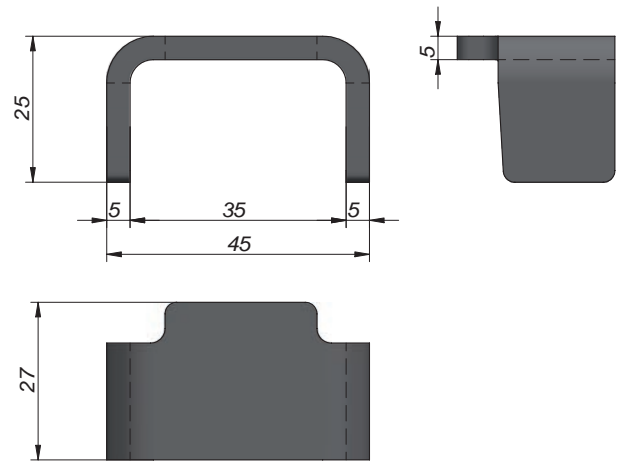
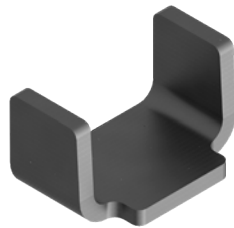

Zinc Plated Encastred Lock
 Einbau-Bordwandverschluss Verzinkt
 Cierre Cartola Empotrado Cincado

Ref	Kg	Mat	Sup/Finish Acabado	Thickn. Espesor	Key Llave	Lot
1201362	1.37	STEEL	Zn	2		2

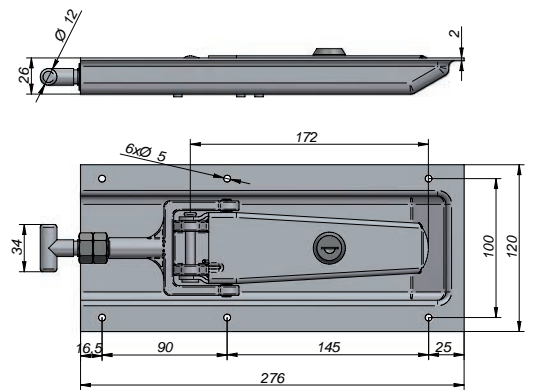

Fix Pocket (Encastred Lock)
 Verschluss-Gegenhalter für Einbau-Bordwandverschluss
 Uña Fija (Cierre Empotrado)

Ref	Kg	Mat	Thickn. Espesor	Lot
1204062	0.21	STEEL	5	10

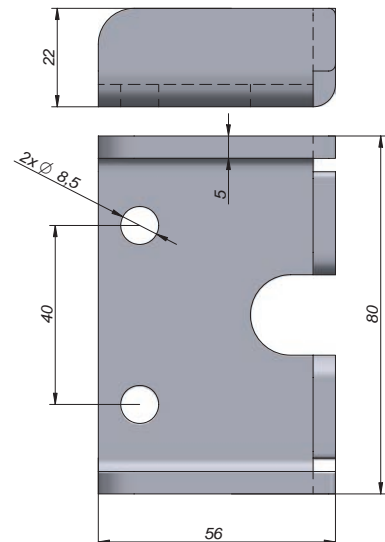

ADA-SLIDER "Tens-Lock" Adjustable Delivery Truck Door Lock
 Verstellbar Verschluss "Tens-Lock" für ADA-SLIDER
 Cierre Puerta "Tens-Lock" ADA-SLIDER Ajustable

Ref	Kg	Mat	Sup/Finish Acabado	Key Llave	Lot
1201372	2.54	STEEL	KTL		1

Tens-Lock permits tightening the curtain horizontally by regulation of 2 nuts | internal spring which will softly taking it to its original position
 Tens-Lock permite tensar la lona horizontalmente mediante la simple regulación de 2 tuercas | muelle interno para cerrarlo a su posición original

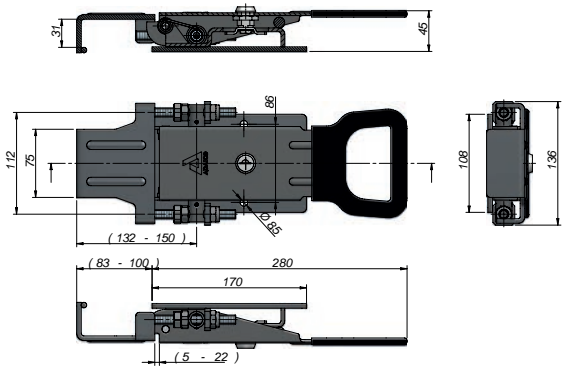
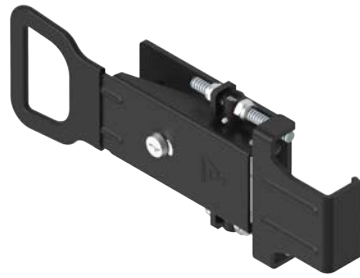

ADA-SLIDER Delivery Truck Door Lock
 Verschluss ADA-SLIDER
 Cierre Botellero Puerta ADA-SLIDER

Ref	Kg	Mat	Sup/Finish Acabado	Key Llave	Lot
1201375	2.26	STEEL	KTL		2

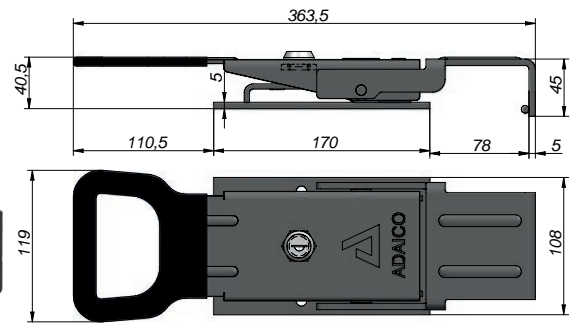

ADA-SLIDER Delivery Truck Double Door Lock
 Verschluss Doppel ADA-SLIDER
 Cierre Doble Botellero Puerta ADA-SLIDER

Ref	Kg	Mat	Sup/Finish Acabado	Key Llave	Lot
1201374	7.6	STEEL	KTL		1

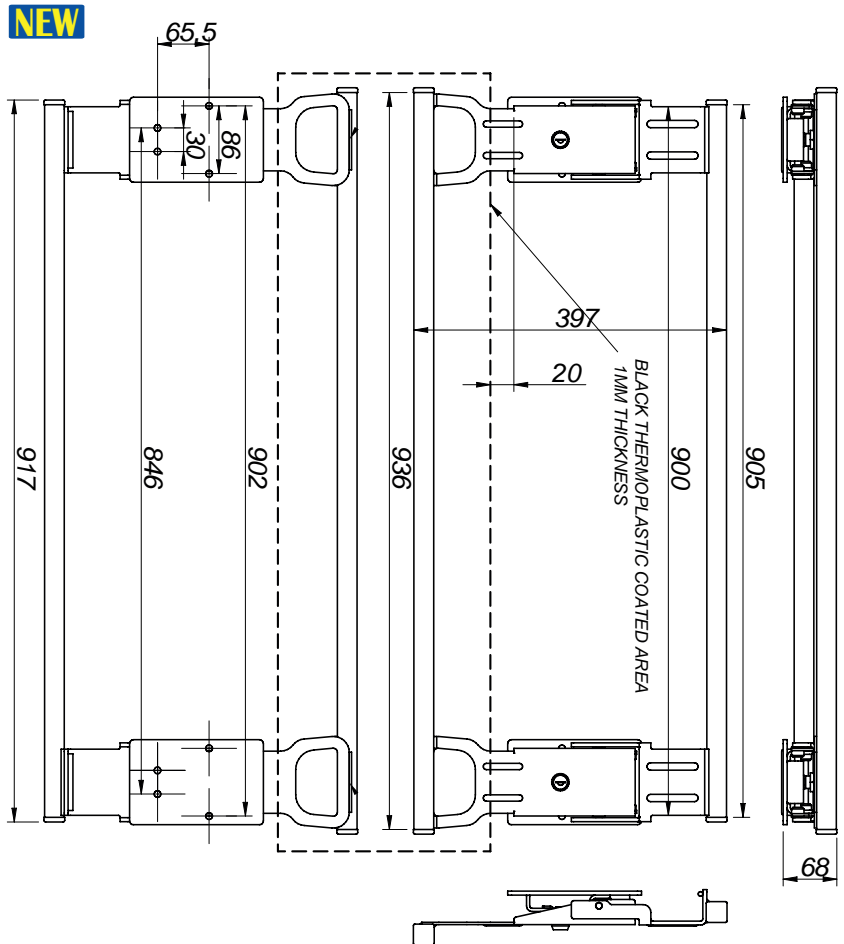
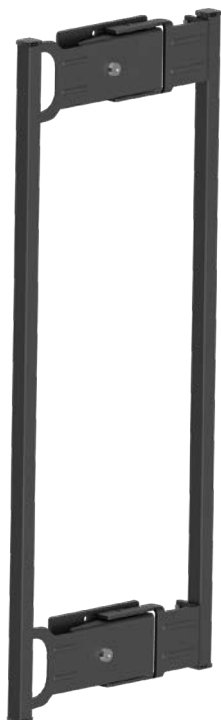



LOCKS AND CLAMPS / VERSCHLÜSSE / CIERRES Y UÑAS

LOCKS / VERSCHLÜSSE / CIERRES

Steel Holder (ADA-SLIDER Lock)
Verschluss-Gegenhalter (ADA-SLIDER Verschluss)
Resbalón Acero (Cierre ADA-SLIDER)

Ref	Kg	Mat	Lot
1201385	0.2	STEEL	4

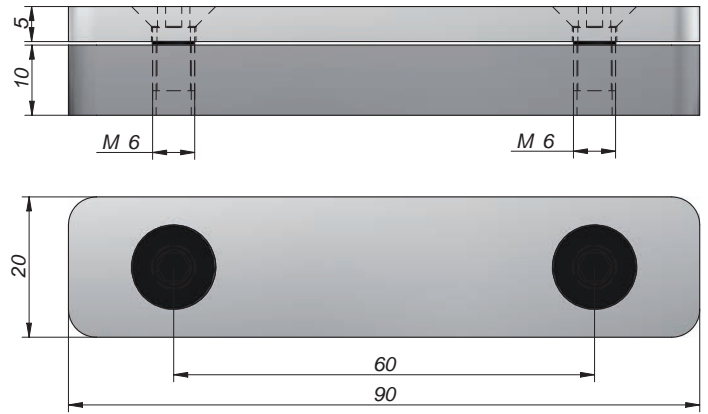

Lock Cylinder w/Key
Schließzylinder m/Schlüssel
Bombín c/Llave

Ref	Kg	Mat	A	Article	Key Llave	Lot
1201383	0.07	STEEL	Ø20	For Lock 1201362 Para cierre 1201362		2
1201384	0.07	STEEL	Ø18	For Locks 1201372/74/75 Para cerrres 1201372/74/75		2

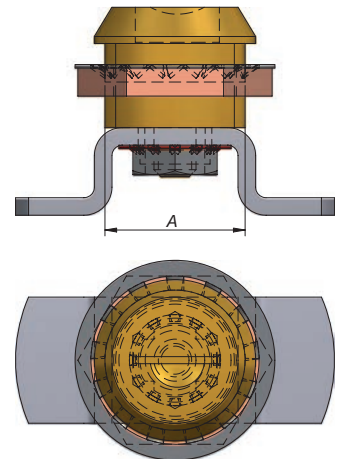

Handle
Handgriff
Manilla Roscada

Ref	Kg	Mat	Sup/Finish Acabado	A	B	C	D	E	F	Ø	Thread Rosca	Lot
1201253	0.25	Forged	Zn	125	37	39	19	Ø13	103.5	14	5/8"	2
1201255	0.26	Forged	Zn	136	43	41	20	Ø13	115	17	3/4"	2

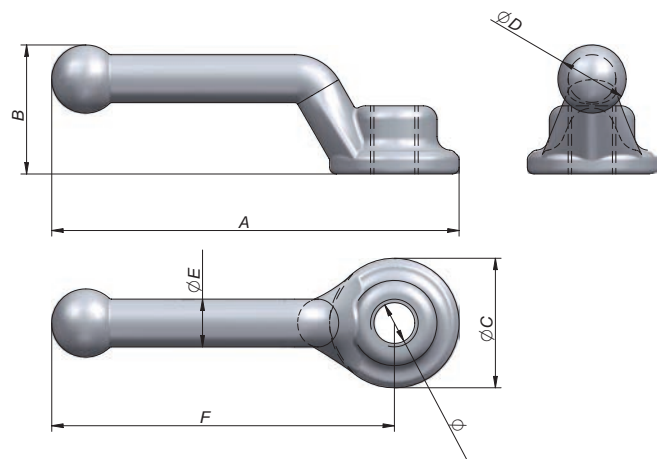

Tiltable Lateral Lock with Catch
Kipphebelverschluss
Cierre Lateral Abatible c/Uña

Ref	Kg	Mat	Pos	Lot
1201270	1.2	STEEL		1
1201271	1.2	STEEL		1



Lock with Pick
Spannverschluss
Cierre de Pico

1201281 - R

Ref	Kg	Mat	Pos	Lot
1201280	0.73	Forged		100
1201281	0.73	Forged		100

1201280 - L

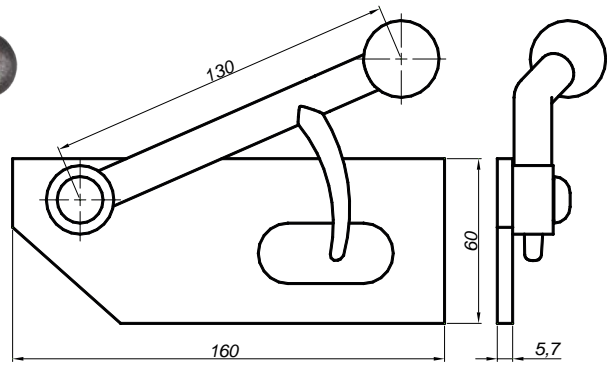

Clamp for Lock with Pick
Gegenhalter für Spannverschluss
Enganche para Cierre de Pico

Ref	Kg	Mat	Pos	Lot
1201282	0.05	Forged		100

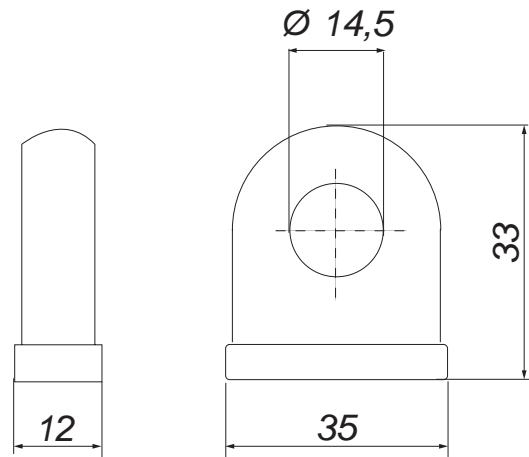

Tipper Lorry Lock Ø18
Muldenkipper Verschluss Ø18
Cierre Volquete Tipo "Carro-Bote" Ø18

Ref	Kg	Mat	Ø	Lot
1201265	1.4	STEEL	18	1

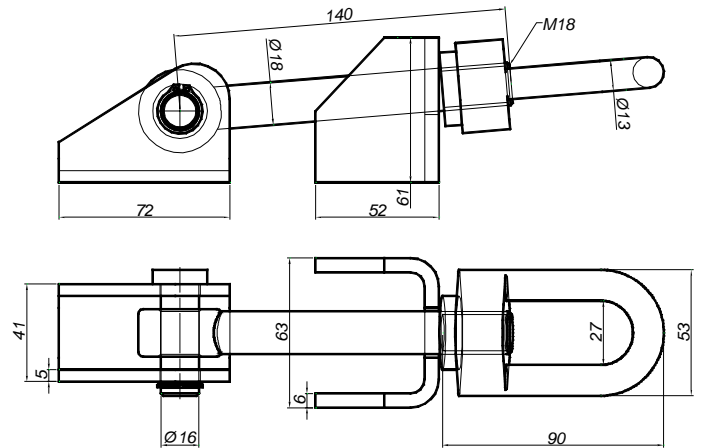

Stainless Steel Door Lock and Hook
Klappenverschluss-Bügel Edelstahl
Cierre Portillón Inox-Enganche

Ref	Kg	Mat	Lock Type Cierre	Lot
1203025	0.28	INOX		1
1203030	0.03			1

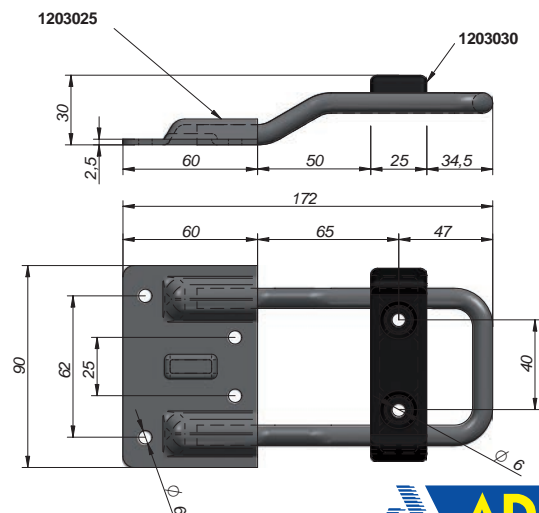



SPRING RUNNER CLAMPS / FEDERRIEGEL / TIRADORES DE MUELLE

LOCKS / VERSCHLÜSSE / CIERRES

Spring Runner Clamp 165xØ12 with Safety Device
 Federriegel-Verschluss 165xØ12 m/Sicherung
 Tirador Muelle 165xØ12 Cincado c/Seguro

Ref	Kg	Mat	Sup/Finish Acabado	Lot
1201410	0.36	STEEL	Zn	2

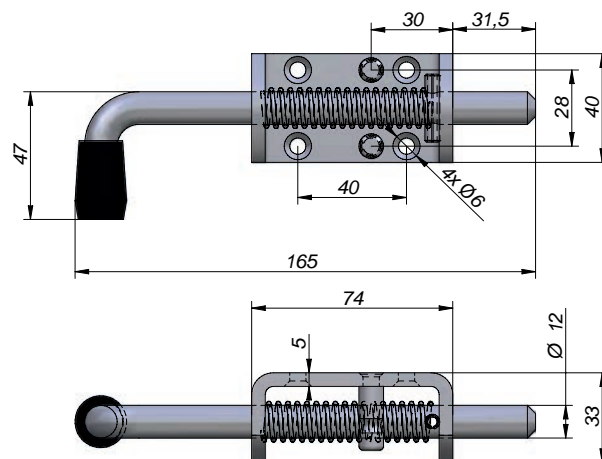
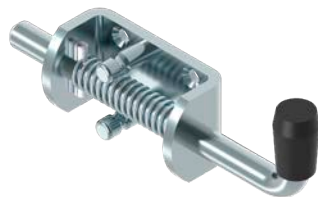

Spring Runner Clamp 190xØ12 with Safety Device
 Federriegel-Verschluss 190xØ12 m/Sicherung
 Tirador Muelle 190xØ12 Cincado c/Seguro

Ref	Kg	Mat	Sup/Finish Acabado	Lot
1201412	0.37	STEEL	Zn	2

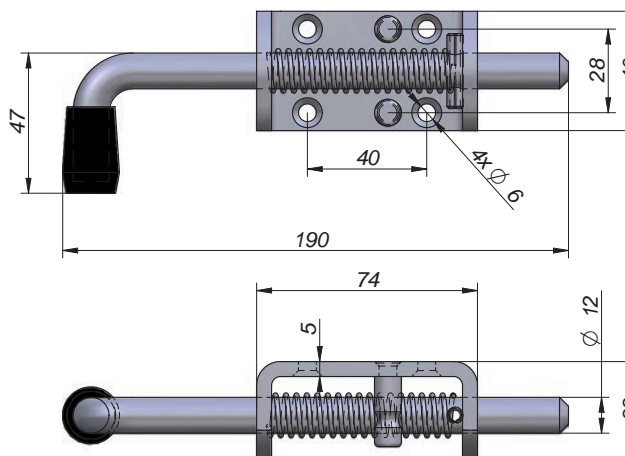
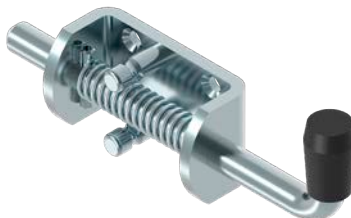

Zinc Plated Spring Runner Clamp 222,5xØ16
 Federriegel-Verschluss 222,5xØ16 Verzinkt
 Tirador Muelle 222,5xØ16 Cincado

Ref	Kg	Mat	Sup/Finish Acabado	Lot
1201413	0.69	STEEL	Zn	2

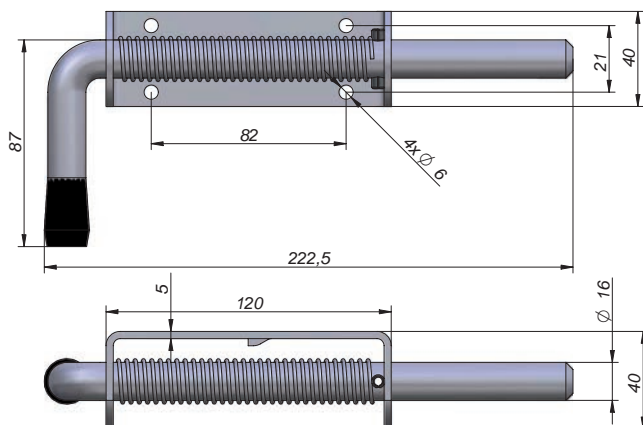

Steel Lock 180xØ10 with Spring
 Verschluss 180xØ10 Stahl mit Feder innenliegend
 Cierre Ganadero 180xØ10 Acero c/Muelle

Ref	Kg	Mat	Lot
1201430	0.23	STEEL	2

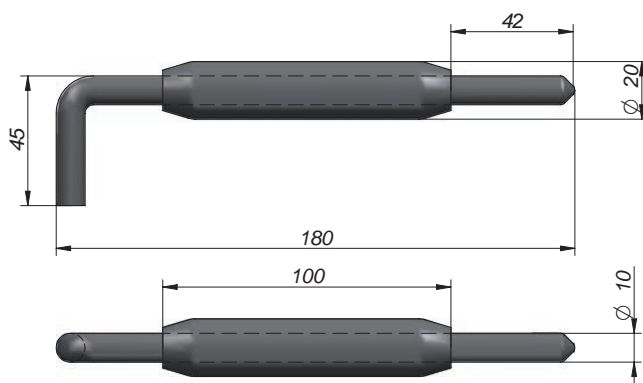

Steel Lock 182xØ14 with Spring
 Verschluss 182xØ14 Stahl mit Feder innenliegend
 Cierre Ganadero 182xØ14 Acero c/Muelle

Ref	Kg	Mat	Lot
1201440	0.33	STEEL	2

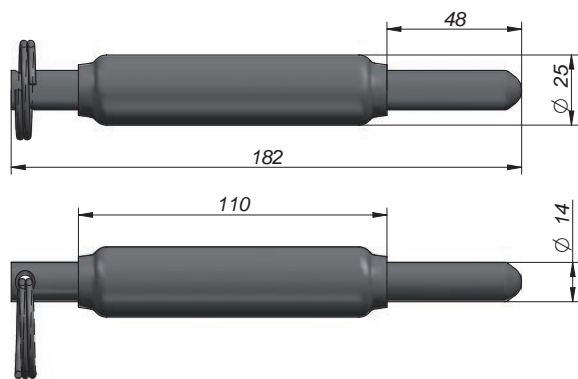

LOCKS / VERSCHLÜSSE / CIERRES

Bolt with Spring
 Federriegel
 Cerrojo c/Muelle

Ref	Kg	Mat	Sup/Finish Acabado	A	B	C	Lot
1201470	0.14	STEEL	Zn	72	55	Ø14	5
1201472	0.14	STEEL	Zn	70	52	Ø12	5
1201474	0.14	STEEL	Zn	72	55	Ø10	2

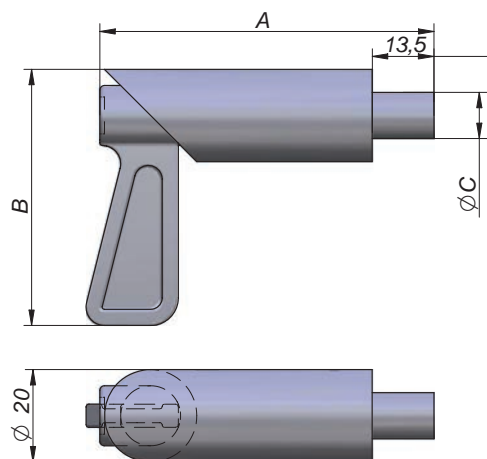



BOX LOCKS / KASTENVERSCHLÜSSE / CIERRES DE CAJÓN

LOCKS / VERSCHLÜSSE / CIERRES

Adjustable Paddle Lock (Whole Stainless Steel)
Kastenverschluss, Verstellbar (Ganzen Teil Edelstahl)
Cierre Cajón Regulable (Entero Inox)

Ref	Kg	Mat	Sup/Finish Acabado	Key Llave	Lot
1203002	0.56	INOX			1

Stainless Steel Whole (Body and interior parts) |
Adjustable (25-50)
Entero en Acero Inoxidable (Cuerpo y piezas interiores) |
Regulable (25-50)

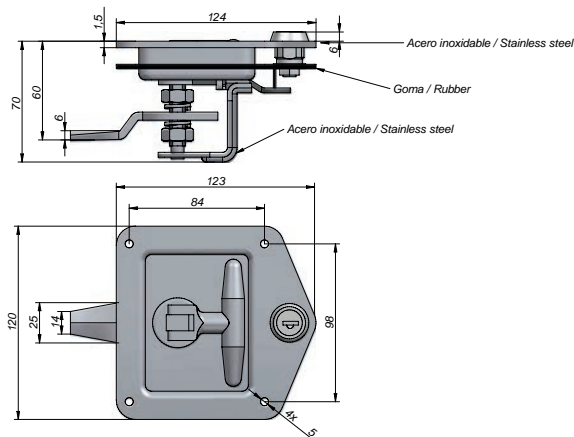

Adjustable Paddle Lock Stainless Steel
Kastenverschluss Edelstahl, Verstellbar
Cierre Cajón Regulable (Inox-Cincado)

Ref	Kg	Mat	Sup/Finish Acabado	Key Llave	Lot
1203003	0.56	INOX			1

Stainless Steel Body | Internal parts in zinc plated steel |
Adjustable (25-50)
Cuerpo en Acero Inoxidable | Piezas interiores en acero cincado |
Regulable (25-50)

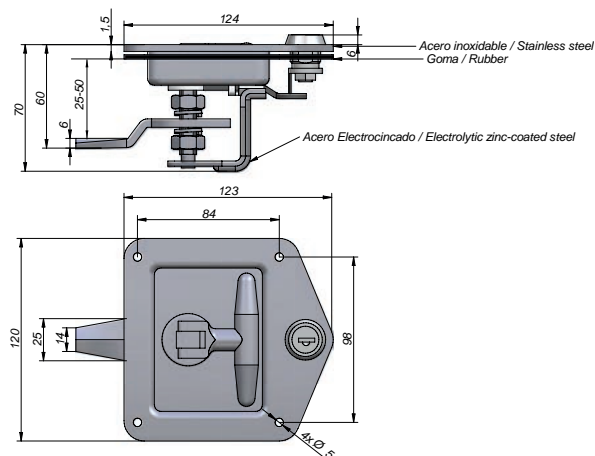

Paddle Lock INOX 145x115
Kastenverschluss INOX 145x115
Cierre Cajón INOX 145x115

Ref	Kg	Mat	Sup/Finish Acabado	Thickn. Espesor	Key Llave	Lot
1203005	0.56	INOX		1.2		1

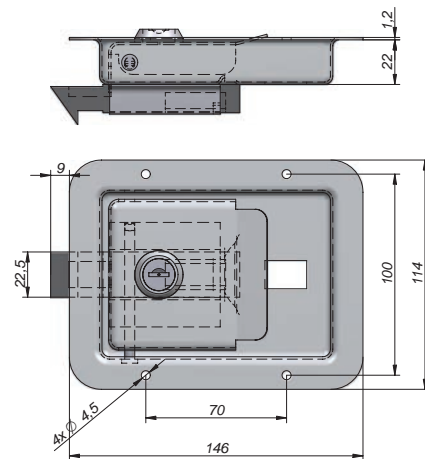

Paddle Lock INOX 120x90
Kastenverschluss INOX 120x90
Cierre Cajón INOX 120x90

Ref	Kg	Mat	Sup/Finish Acabado	Thickn. Espesor	Key Llave	Lot
1203007	0.45	INOX		1.2		1

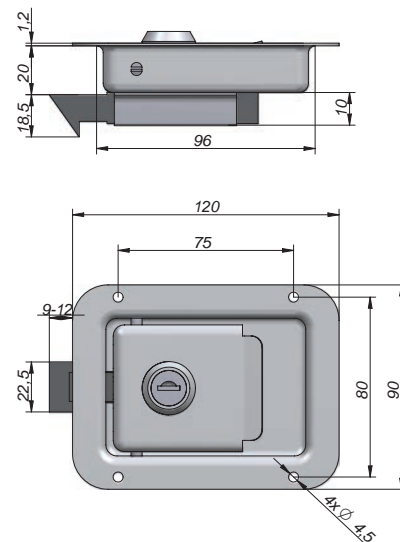

Paddle Lock Encastred 140x90 Black
 Kastenverschluss Innenliegend 140x90 Schwarz
 Cierre Cajón Empotrado Negro 140x90 Apertura interior

Ref	Kg	Mat	Sup/Finish Acabado	Col	Thickn. Espesor	Key Llave	Lot
1203017	0.4	STEEL			1.2		1

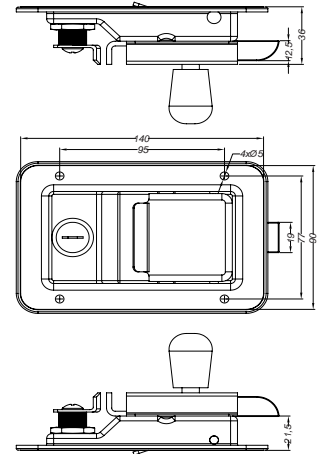

Paddle Lock Encastred 140x90 Stainless Steel
 Kastenverschluss Innenliegend 140x90 Edestahl
 Cierre Cajón Empotrado Inox 140x90 Apertura interior

Ref	Kg	Mat	Sup/Finish Acabado	Thickn. Espesor	Key Llave	Lot
1203018	0.4	INOX		1.2		1

Low carbon steel mechanism: (Latch, Cam, Cylinder)
 Mecanismo en Acero bajo carbono: (Pestillo, Leva, Bombín)

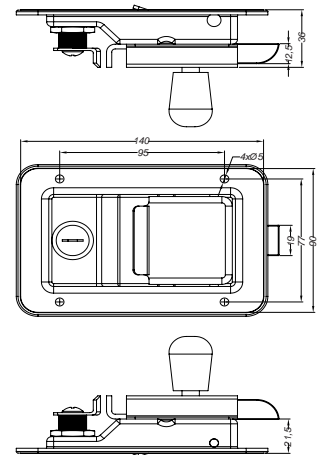

Interior Black Lock
 Kastenverschluss Innenliegend Schwarz
 Cierre de Cajón Empotrado

Ref	Kg	Mat	Sup/Finish Acabado	Col	Key Llave	Lot
1203016	0.28	STEEL				1

Adjustable depth (1-35 mm.)
 Profundidad regulable (1-35 mm.)

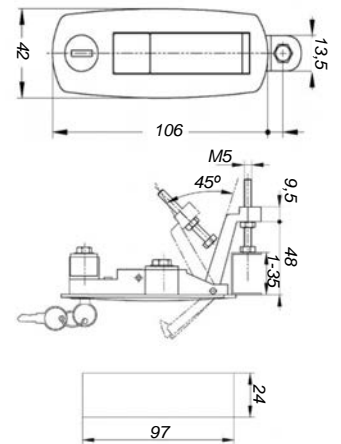
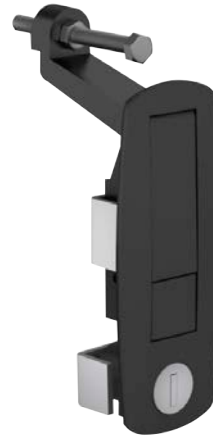

Box Lock 115x22x11,5 Steel
 Zungenriegel-Verschluss 115x22x11,5
 Cierre Cajón 115x22x11,5 Acero

Ref	Kg	Mat	Sup/Finish Acabado	Col	Lot
1203058	0.1	STEEL			2

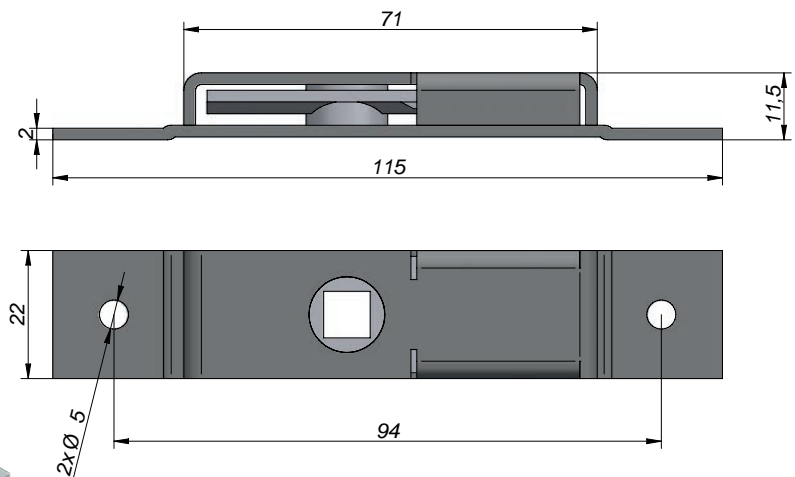
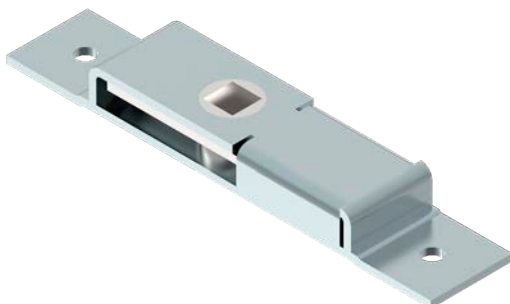



BOX LOCKS / KASTENVERSCHLÜSSE / CIERRES DE CAJÓN

LOCKS / VERSCHLÜSSE / CIERRES

Box Lock 126x25x13 Steel
Zungenriegel-Verschluss 126x25x13
Cierre Cajón 126x25x13 Acero Inoxidable

Ref	Kg	Mat	Lot
1203062	0.17	INOX	1

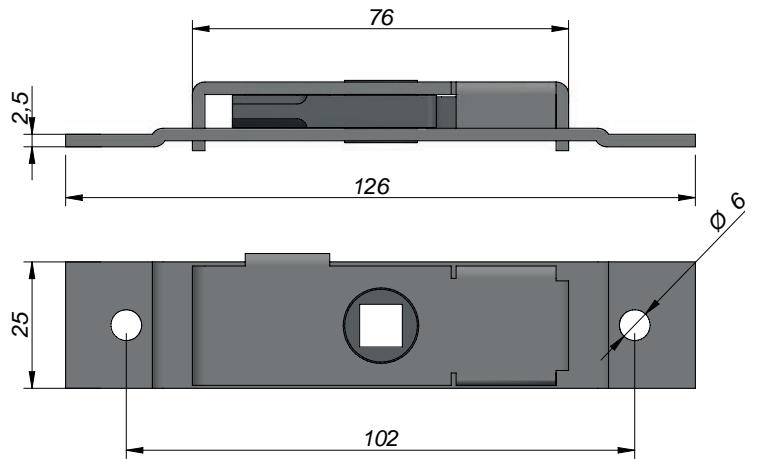
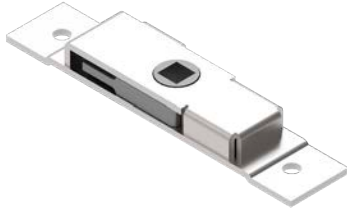

Key Lock Box
Multi-Vierkantschlüssel
Llave Cierre Cajón

Ref	Kg	Mat	Lot
1203094	0.11	STEEL	1

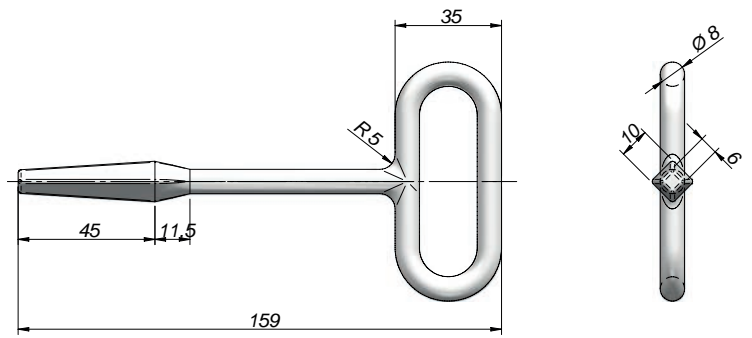
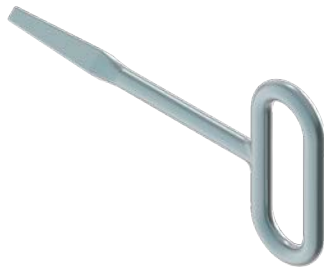

Delivery Truck Door Gear (Ø21 mm.), Reversible
 Drehstangenverschluss (Ø21 mm.), Reversibel
 Cierre Furgón Trasero (Ø21 mm.) Reversible

Ref	Kg	Mat	Sup/Finish Acabado	Pos	Ø	Key Llave	Lot
1202016	2.86	STEEL	Zn		21		1

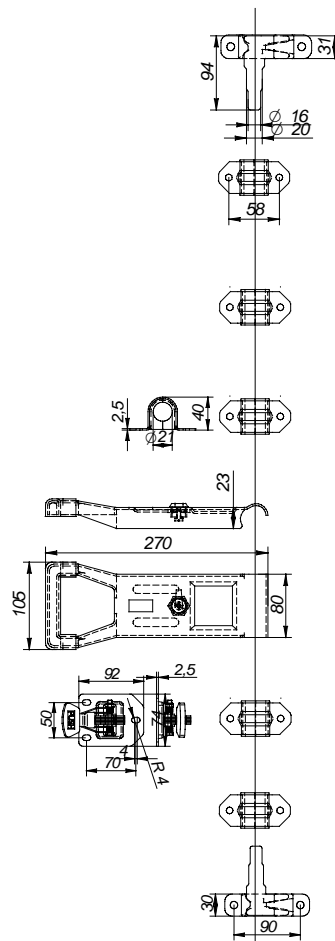
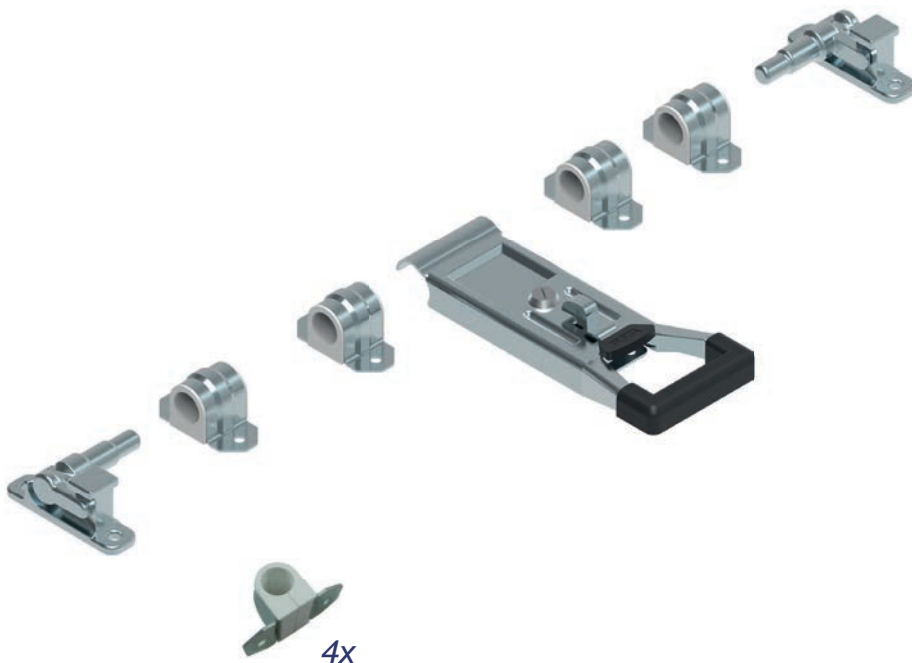

Trailer Door Gear (Ø27 mm.), Reversible
 Drehstangenverschluss (Ø27 mm.), Reversibel
 Cierre Furgón Trasero (Ø27 mm.), Reversible

Ref	Kg	Mat	Sup/Finish Acabado	Pos	Ø	Key Llave	Lot
1202028	3.09	STEEL	Zn		27		1

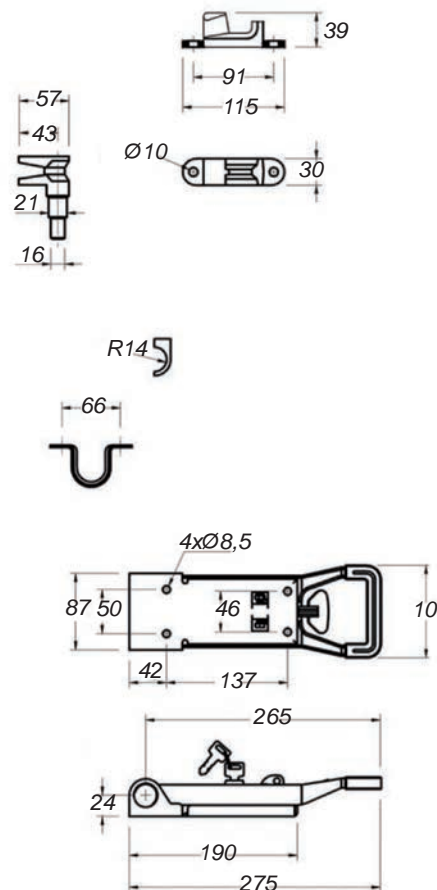
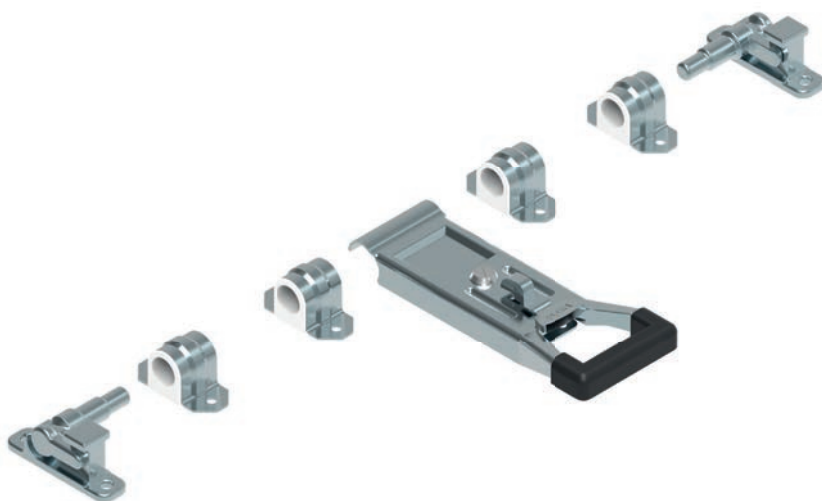



TRAILER DOOR GEAR / DREHSTANGENVERSCHLÜSSE / CIERRES FALLEBA

LOCKS / VERSCHLÜSSE / CIERRES

Trailer Door Gear (Ø27 mm.) Stainless Steel, Reversible
 Drehstangenverschluss (Ø27 mm.) Edelstahl, Reversibel
 Cierre Furgón Trasero (Ø27 mm.) Inox, Reversible

Ref	Kg	Mat	Pos	Ø	Key Llave	Lot
1202004	4.5	INOX		27		1

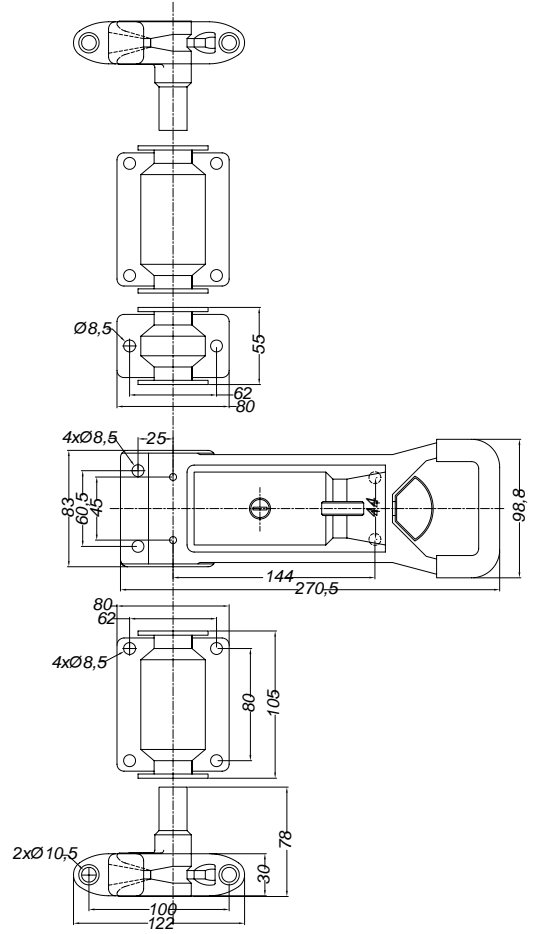
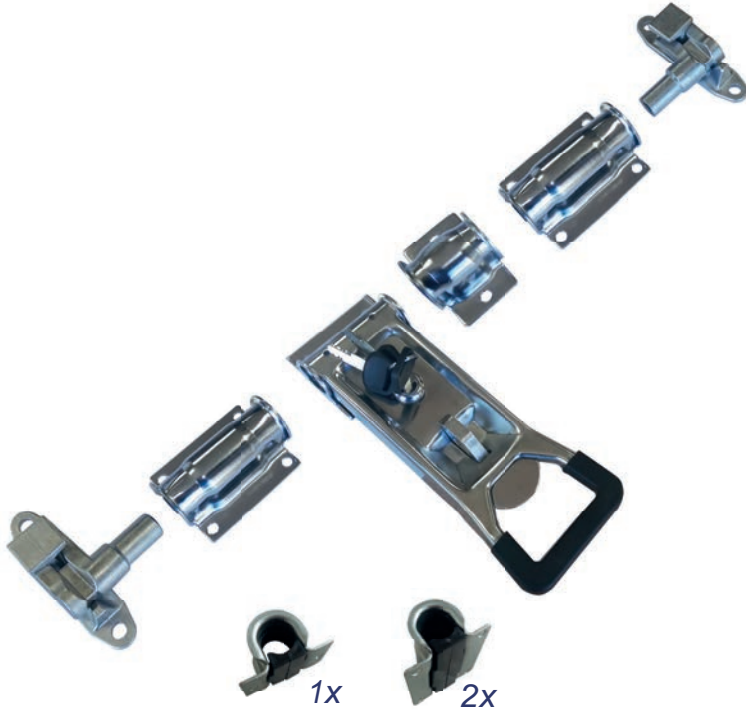

Container Trailer Door Gear (Ø27 mm.), Reversible
 Drehstangenverschluss Container (Ø27 mm.), Reversibel
 Cierre Falleba Container Asa (Ø27 mm.) Reversible, Reversible

Ref	Kg	Mat	Sup/Finish Acabado	Pos	Ø	Lot
1202029	5.34	STEEL	Zn		27	1
1202031	5.34	INOX			27	1

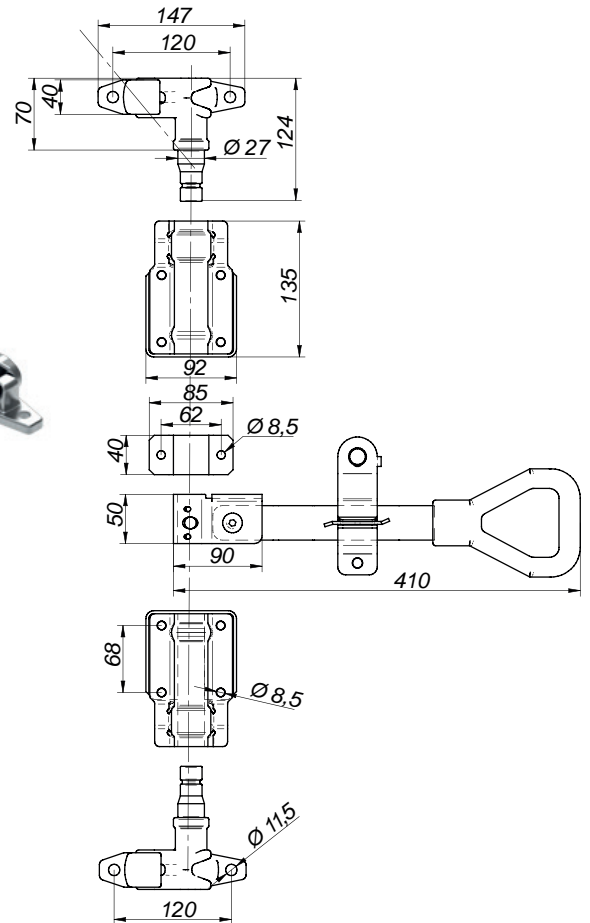



Trailer Door Gear (Ø27 mm.)
Drehstangenverschluss (Ø27 mm.)
Cierre Falleba (Ø27 mm.)

Ref	Kg	Mat	Sup/Finish Acabado	Pos	Ø	Lot
1202022	5.58	STEEL	Zn		27	1
1202023	5.58	STEEL	Zn		27	1

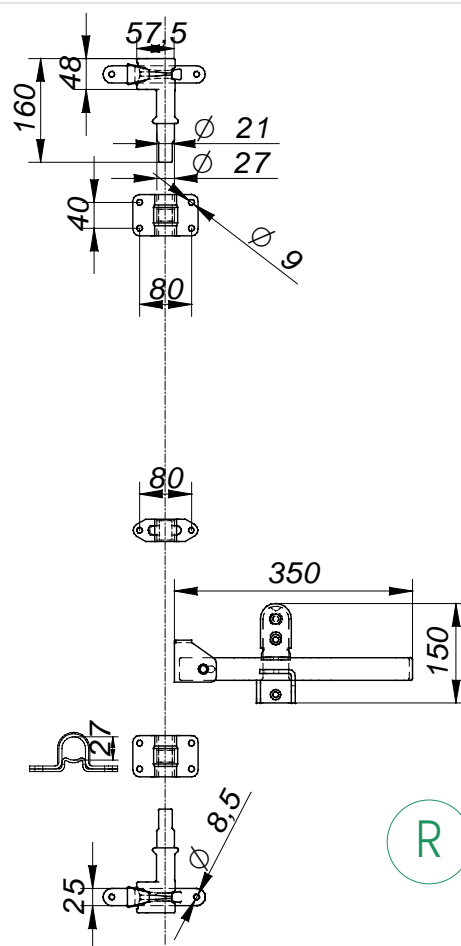
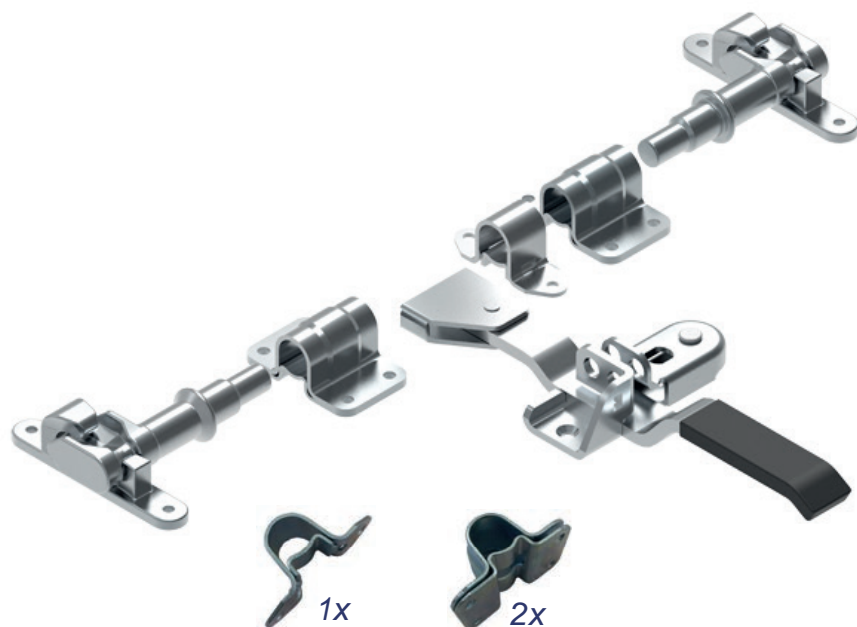

LOCKS / VERSCHLÜSSE / CIERRES

Trailer Door Gear (Ø27 mm.), Reversible
Drehstangenverschluss (Ø27 mm.), Reversibel
Cierre Falleba (Ø27 mm.), Reversible

Ref	Kg	Mat	Sup/Finish Acabado	Pos	Ø	Lot
1202024	4.98	STEEL	Zn		27	1
1202032	4.98	INOX			27	1

NEW

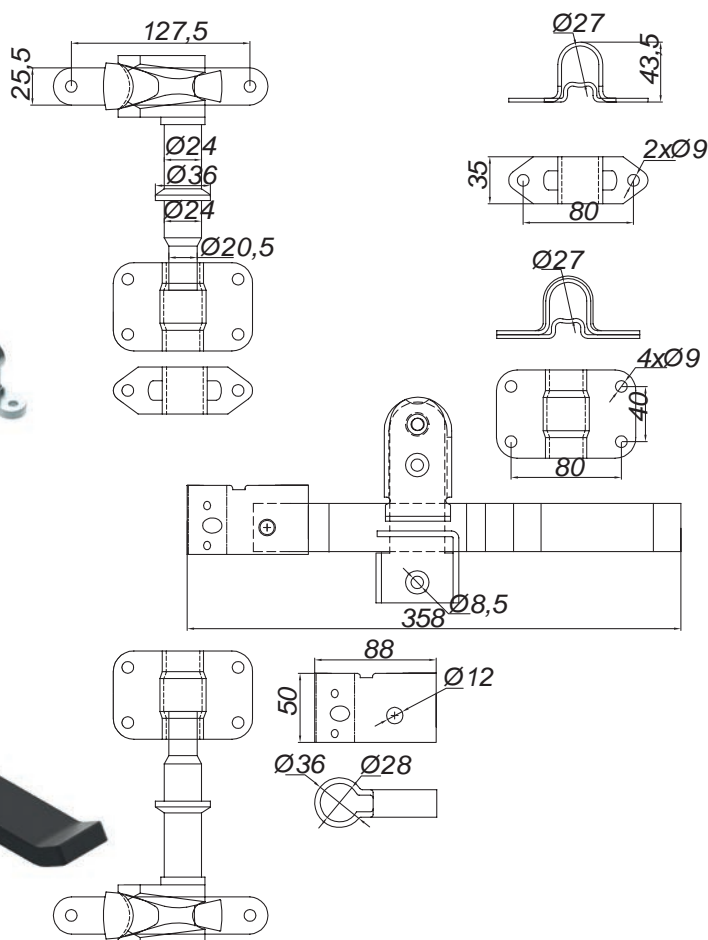
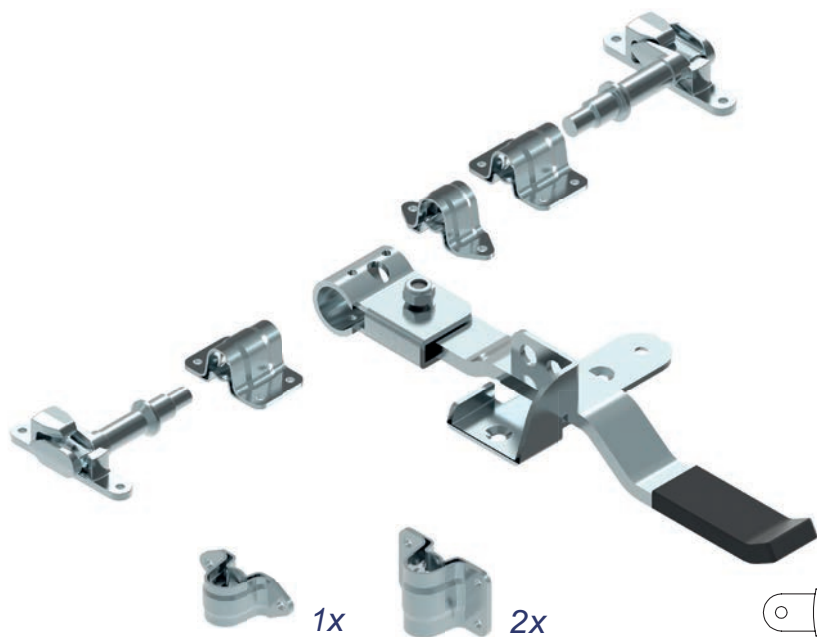



TRAILER DOOR GEAR / DREHSTANGENVERSCHLÜSSE / CIERRES FALLEBA

LOCKS / VERSCHLÜSSE / CIERRES

Rear Lock Flat Exterior (Ø27 mm.) Stainless Steel, Reversible
 Drehstangenverschluss Aussenliegend (Ø27 mm.) Edelstahl, Reversibel
 Cierre Externo (Ø27 mm.) Acero Inoxidable, Reversible

Ref	Kg	Mat	Pos	Ø	Key Llave	Lock Type Cierre	Lot
1202120	0.99	INOX		27			2
1202128	0.55	INOX		27			2
1202140	0.27	INOX		27			3
1202272	1.68	INOX		27			1

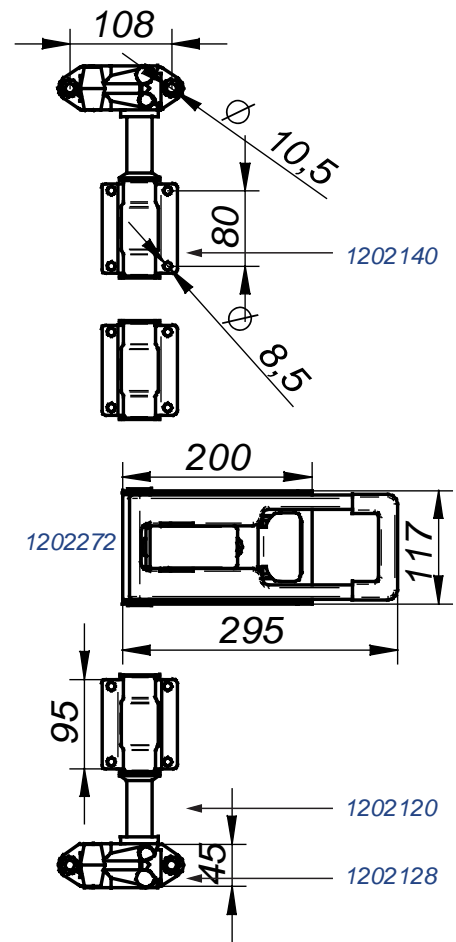

Rear Lock Flat Exterior (Ø21 mm.) Stainless Steel, Reversible
 Drehstangenverschluss Aussenliegend (Ø21 mm.) Edelstahl, Reversibel
 Cierre Externo (Ø21 mm.) Acero Inoxidable, Reversible

Ref	Kg	Mat	Pos	Ø	Key Llave	Lock Type Cierre	Lot
1202124	0.54	INOX		21			2
1202129	0.26	INOX		21			2
1202142	0.15	INOX		21			2
1202278	1.57	INOX		21			1

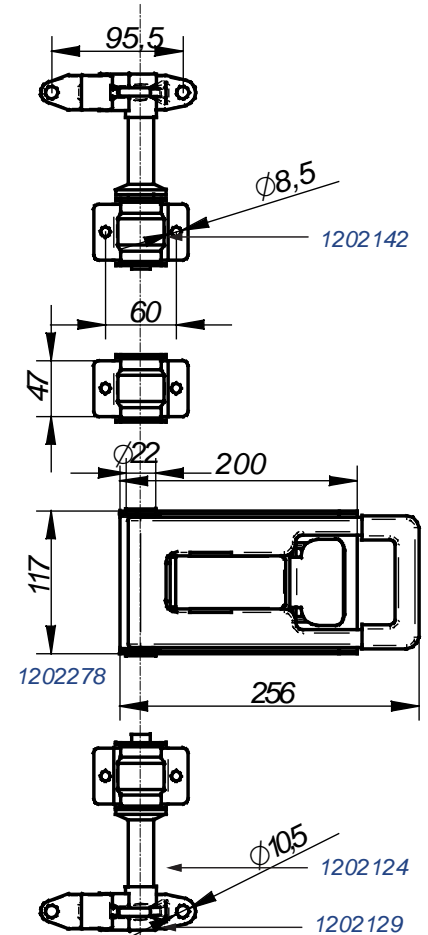

Rear Lock Flat Interior (Ø16 mm.) Stainless Steel, Reversible
 Drehstangenverschluss Innenliegend (Ø16 mm.) Edelstahl, Reversibel
 Cierre Empotrado (Ø16 mm.) Acero Inoxidable, Reversible

Ref	Kg	Mat	Pos	Ø	Key Llave	Lock Type Cierre	Lot
1202214	1.66	INOX		16			1
1202386	0.13	INOX		16			1
1202387	0.13	INOX		16			1
1202388	0.15	INOX		16			2

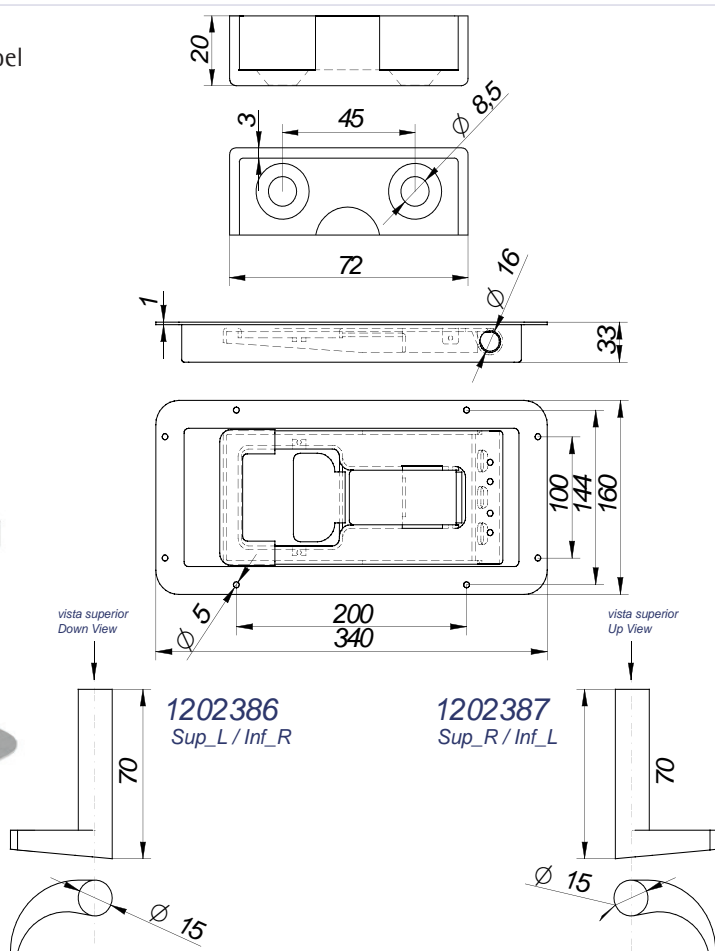
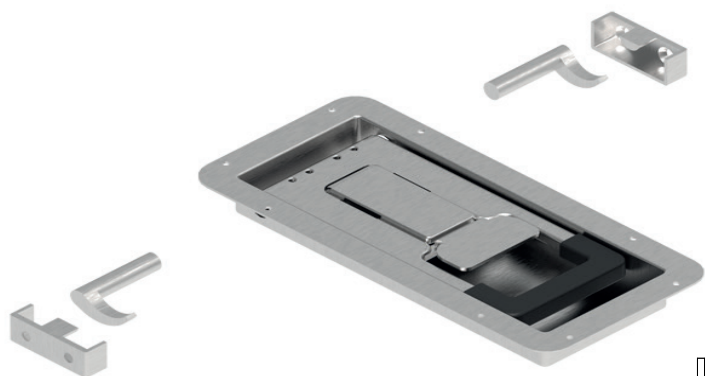

LOCKS / VERSCHLÜSSE / CIERRES

Lock Superkit
 Verschluss Superkit
 Cierre Superkit Completo

Ref	Kg	Mat	Sup/Finish Acabado	Ø	Lock Type Cierre	Lot
1202092	2.94	STEEL	Zn	16		1
1202093	2.3	STEEL	Zn	18		1

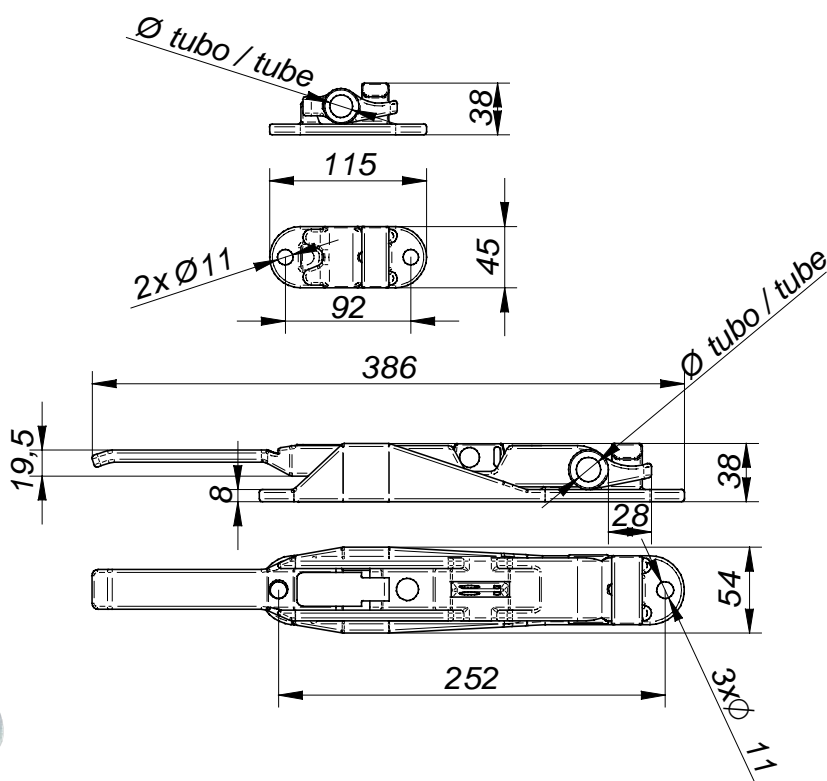
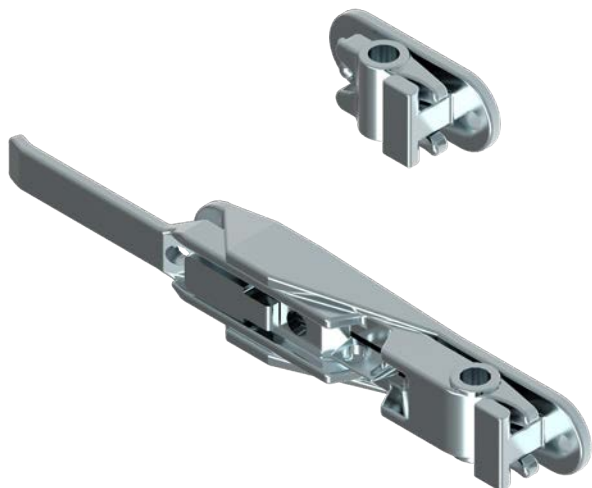



TRAILER DOOR GEAR / DREHSTANGENVERSCHLÜSSE / CIERRES FALLEBA

LOCKS / VERSCHLÜSSE / CIERRES

Top Cam for Superkit Lock Ø18
Höher Spannzapfen für Superkit Ø18
Leva Superior para Cierre Superkit Ø18

Ref	Kg	Mat	Sup/Finish Acabado	Ø	Lock Type Cierre	Lot
1202101	0.23	STEEL	Zn	18		1

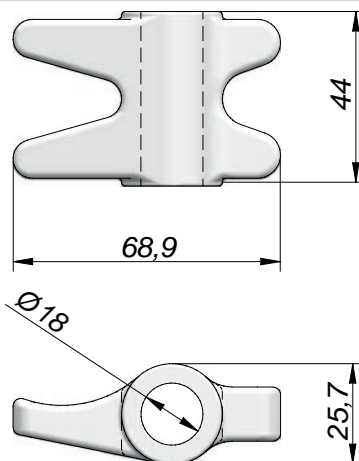

Top Keeper for Superkit Lock Ø18
Höherhalter für Superkit Ø18
Cremona Superior para Cierre Superkit Ø18

Ref	Kg	Mat	Sup/Finish Acabado	Ø	Lock Type Cierre	Lot
1202103	0.37	STEEL	Zn	18		1

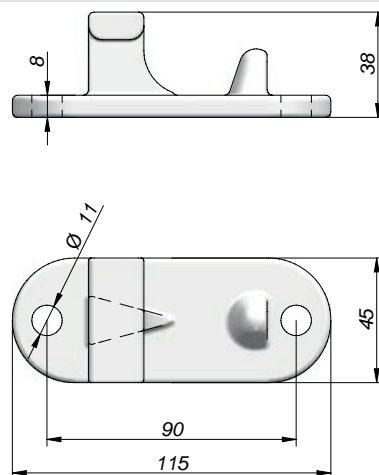

Superkit Lock Keeper Ø18
Gegenhalter Verschluss Superkit Ø18
Cremona Cierre Superkit Ø18

Ref	Kg	Mat	Sup/Finish Acabado	Ø	Lock Type Cierre	Lot
1202097	0.91	STEEL	Zn	18		10

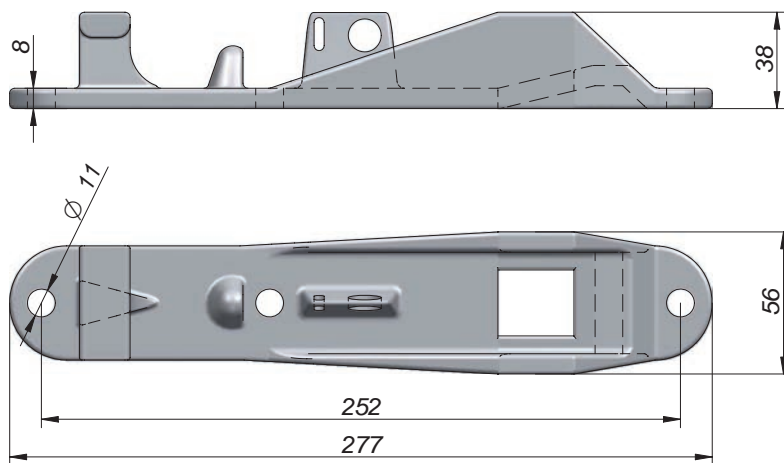

Superkit Lock Handle Ø18
Griff Verschluss Superkit Ø18
Manilla Cierre Superkit Ø18

Ref	Kg	Mat	Sup/Finish Acabado	Ø	Lock Type Cierre	Lot
1202100	0.84	STEEL	Zn	18		10

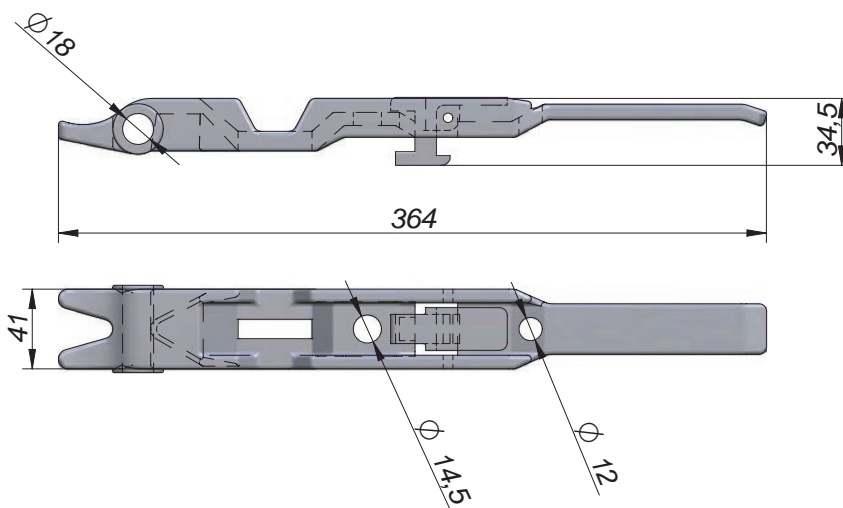

Bisagras

Hinges

Charnières

Scharniere

Dobradiças

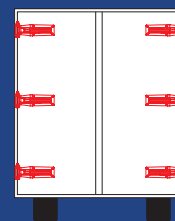

Bisagra Cartola

Sideboard Hinge

Charnière de Ridelle

Bordwandscharnier

Dobradiças de Caixa



pag. 254-255

Bisagra Trasera

Rear Hinge

Penture

Rückwandscharnier

Dobradiça Traseira

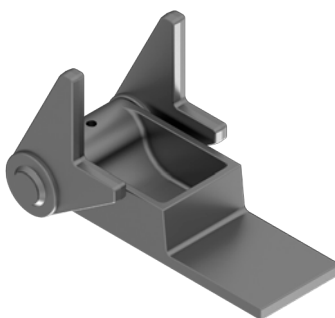

pag. 256-257

Bisagra Lateral

Side Hinge

Charnière Lisse

Seitenscharnier

Dobradiça Lateral

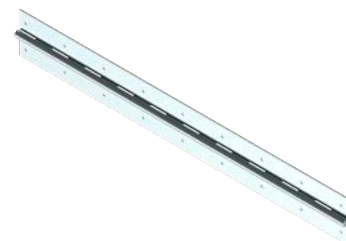
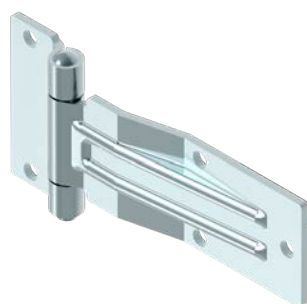

pag. 258-261

Bisagras de Forja

Forged Hinges

Charnière en fer Forgé

Schmiedeeisenscharnier

Dobradiça Forjada

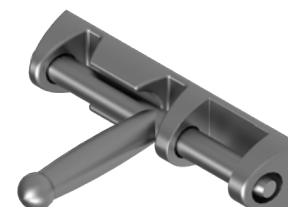
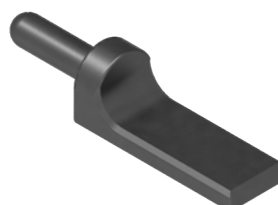

pag. 262-266



SIDEBOARD HINGE / BORDWANDSCHARNIERE / BISAGRA CARTOLA

HINGES / SCHARNIERE / BISAGRAS

Side Board Hinge 174x50
Bordwandscharnier-Oberteil 174x50
Bisagra Baranda Chapa 174x50

Ref	Kg	Mat	Lot
1301120	0.51	STEEL	1

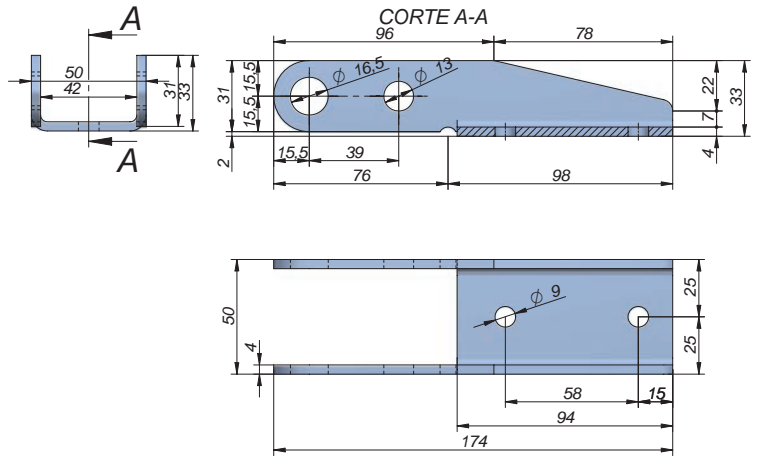

"G" Hinge Support for 1301120
Scharnier-Unterteil "G" (f. 1301120)
Soporte "G" para Bisagra Baranda 1301120

Ref	Kg	Mat	Lot
1301122	0.22	STEEL	1

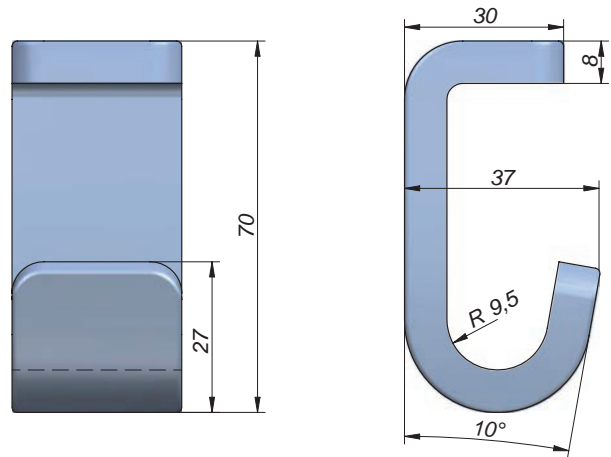

Hinge Pin Zinc TIR-7
Bordwandscharnier-Kit Verzinkt TIR-7
Bisagra TIR-7 Forja-Cincado

Ref	Kg	Mat	Sup/Finish Acabado	Lot
1301140	0.67	STEEL	Zn	2

Zinc Plated Drop Gudgeon | Forged Drop Hinge
Macho Cincado | Hembra Forja

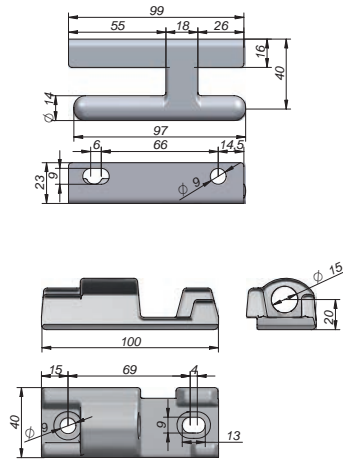

Side Board Hinge (Low Base)
Bordwandscharnier-Kit Verzinkt (Kleine Nut)
Bisagra (Base Baja)

Ref	Kg	Mat	Sup/Finish Acabado	Lot
1301142	0.64	STEEL	Zn	2

Zinc Plated Drop Gudgeon | Forged Drop Hinge
Macho Cincado | Hembra Forja

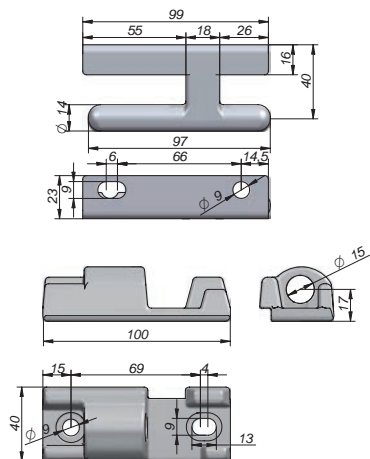

Side Board Hinge Zinc Plated
Bordwandscharnier-Kit Verzinkt
Bisagra Cartola Cincada

Ref	Kg	Mat	Sup/Finish Acabado	Lot
1301160	0.88	Forged	Zn	6

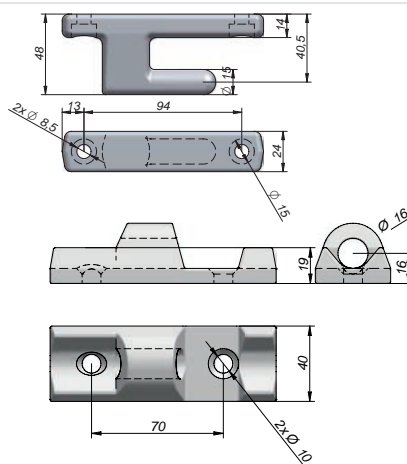

Side Board Hinge Zinc Plated
Bordwandscharnier-Kit Verzinkt
Bisagra Cartola Forja Cincada

Ref	Kg	Mat	Sup/Finish Acabado	Lot
1301170	0.4	Forged	Zn	20

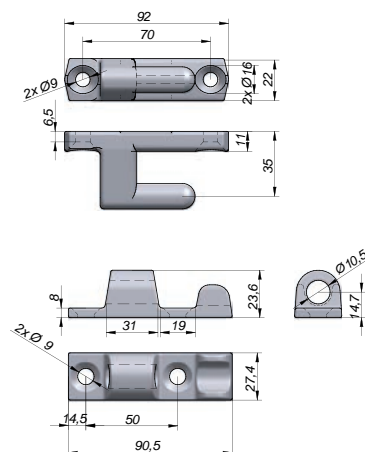

Side Board Hinge
Bordwandscharnier-Kit
Bisagra Cartola Chapa

Ref	Kg	Mat	Sup/Finish Acabado	Lot
1301130	0.49	STEEL	Zn	2

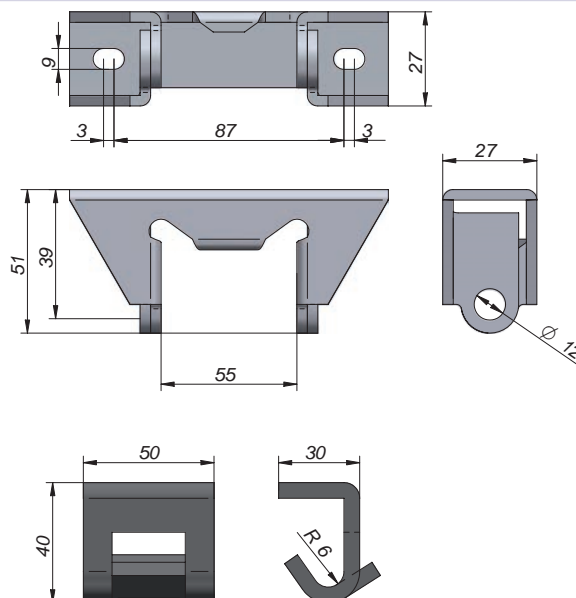



REAR HINGE / HECKTÜRSCHARNIERE / BISAGRA TRASERA

HINGES / SCHARNIERE / BISAGRAS

Rear Hinge 278x120 w/Support
Hecktürscharnier 278x120 mit Scharnierbock
Bisagra Trasera Forja 278x120 c/Soporte

Ref	Kg	Mat	Lot
1302110	1.46	Forged	2

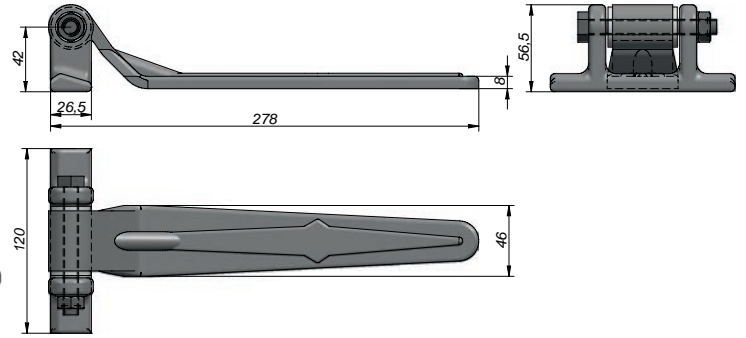

Rear Hinge with Support
Hecktürscharnier mit Scharnierbock
Bisagra Trasera Forja para Basculante c/Soporte

Ref	Kg	Mat	Thickn. Espesor	Lot
1302112	2.86	Forged	7	2

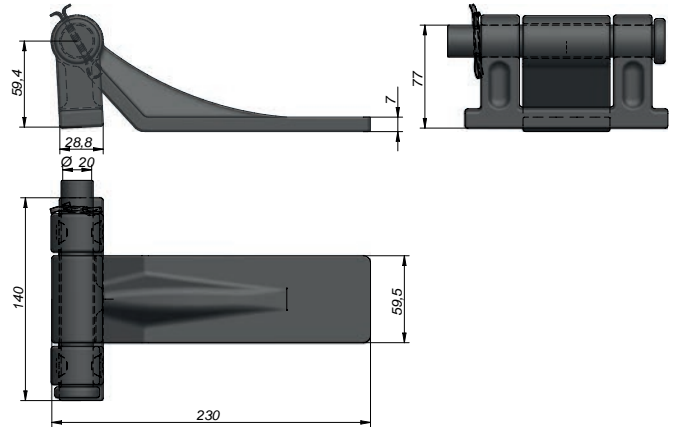
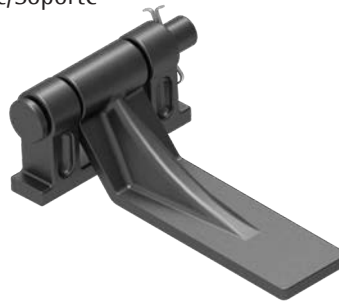

Door Hinge
Heckscharnier
Bisagra para Basculante

Ref	Kg	Mat	Lot
1301116	3.69	Forged	1

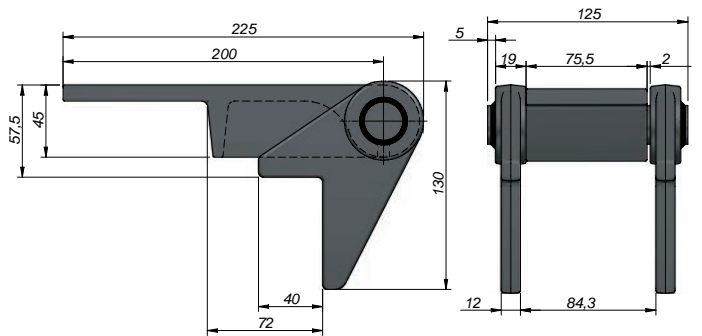
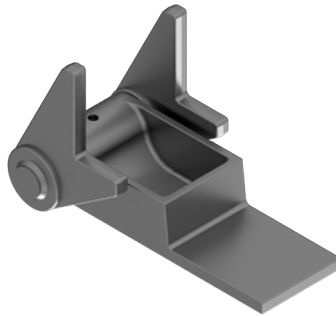

Rear Hinge 330x63xØ12 (4)
Hecktür-Scharnierblatt 330x63xØ12 (4)
Bisagra Trasera 330x63xØ12 (4)

Ref	Kg	Mat	Sup/Finish Acabado	Thickn. Espesor	Lot
1302127	1.08	STEEL	Zn	4	1

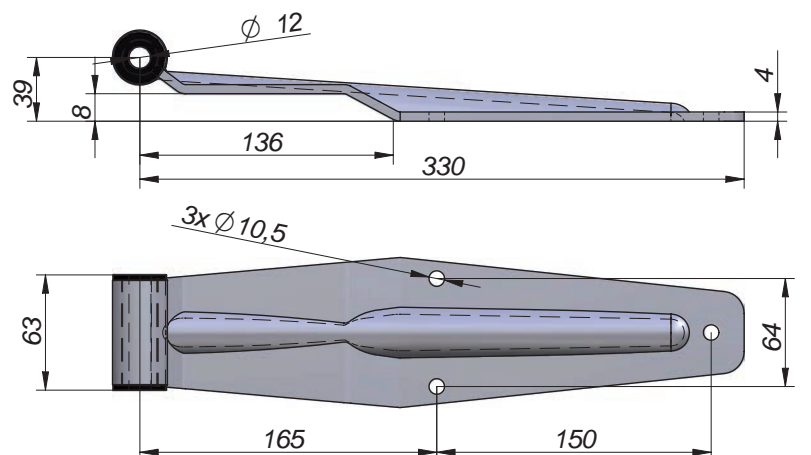

Rear Hinge 246x63xØ12 (5)
 Hecktür-Scharnierblatt 246x63xØ12 (5)
 Bisagra Trasera 246x63xØ12 (5)

Ref	Kg	Mat	Sup/Finish Acabado	Thickn. Espesor	Lot
1302129	0.84	STEEL	Zn	5	2

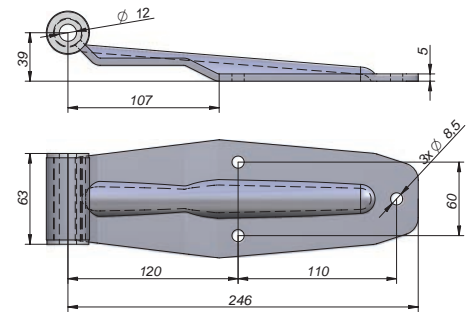

Rear Hinge Support Ø12 with Bolt
 Scharnierbock Ø12 mit Schrauben
 Soporte de Bisagra Trasera Ø12 c/Tornillo-Tuerca

Ref	Kg	Mat	Sup/Finish Acabado	Lot
1302212	0.36	STEEL	Zn	2

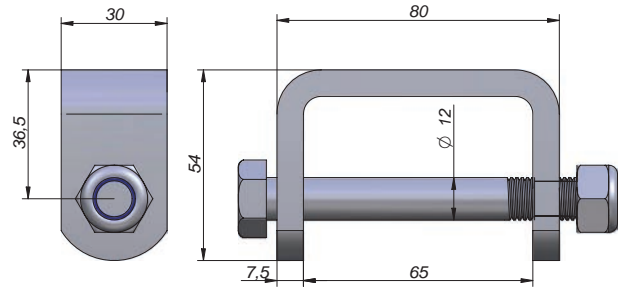

Rear Hinge 295x80 with Support
 Hecktürscharnier 295x80 mit Scharnierbock
 Bisagra Trasera Chapa 295x80 c/Soporte

Ref	Kg	Mat	Sup/Finish Acabado	Thickn. Espesor	Lot
1302136	1.21	STEEL	Zn	4	1

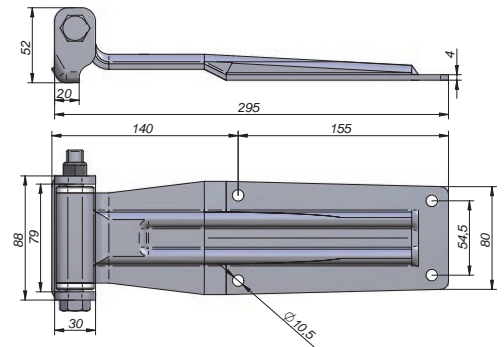
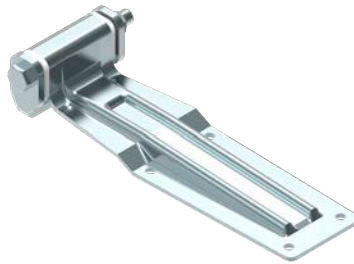

Rear Hinge 255x82 with Support
 Hecktürscharnier 255x82 mit Scharnierbock
 Bisagra Trasera Acero 255x82 c/Soporte

Ref	Kg	Mat	Sup/Finish Acabado	Thickn. Espesor	Lot
1302137	0.7	STEEL	Zn	4	1

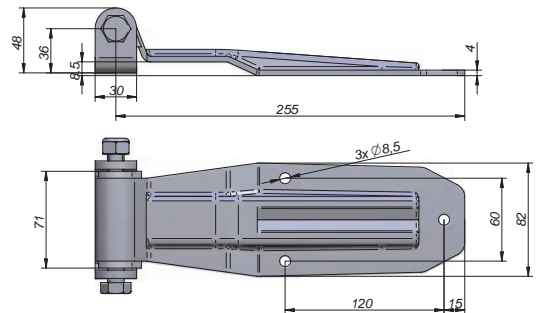

Rear Hinge 262x86 (4) with Support
 Hecktürscharnier 262x86 (4) avec Support
 Bisagra Trasera Chapa 262x86 (4) c/Soporte c/Suporte

Ref	Kg	Mat	Sup/Finish Acabado	Thickn. Espesor	Lot
1302141	1.2	STEEL	Zn	4	1
1302410	1.2	INOX		4	1

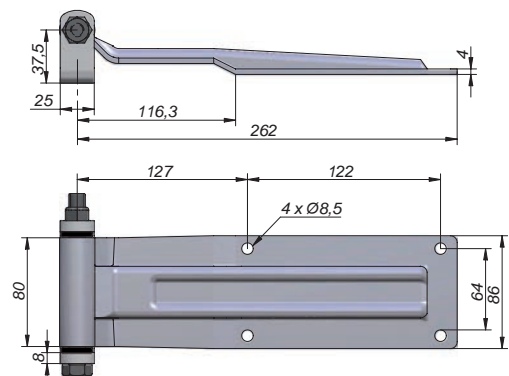
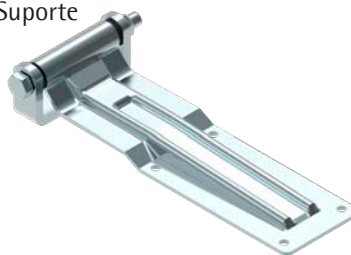

SIDE HINGE / SEITENTÜRSCHARNIERE / BISAGRA LATERAL

HINGES / SCHARNIERE / BISAGRAS

Side Hinge Plane
Seitentürscharnier klein
Bisagra Lateral Lisa

Ref	Kg	Mat	Sup/Finish Acabado	Thickn. Espesor	Lot
1303022	0.15	STEEL	Zn	4	10
1303202	0.15	INOX		4	10

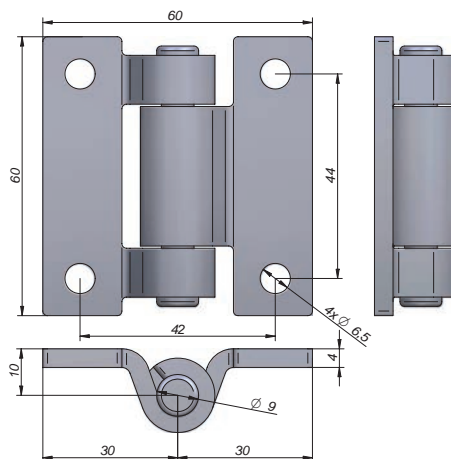

Side Hinge Nerve
Seitentürscharnier gesickt Verzinkt
Bisagra Lateral Nervio Cincado

Ref	Kg	Mat	Sup/Finish Acabado	Thickn. Espesor	Lot
1303025	0.87	STEEL	Zn	5	4

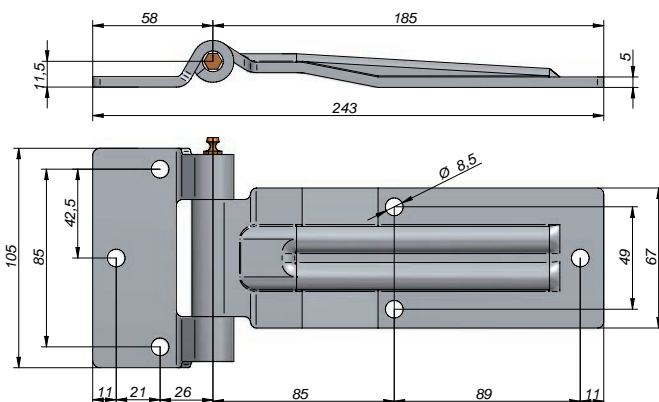
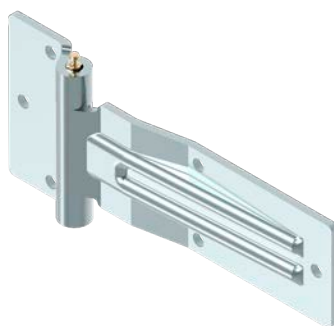

Side Hinge Nerve
Seitentürscharnier gesickt
Bisagra Lateral Nervio

Ref	Kg	Mat	Sup/Finish Acabado	Thickn. Espesor	Lot
1303032	0.4	STEEL	Zn	4	2
1303232	0.4	INOX		4	1

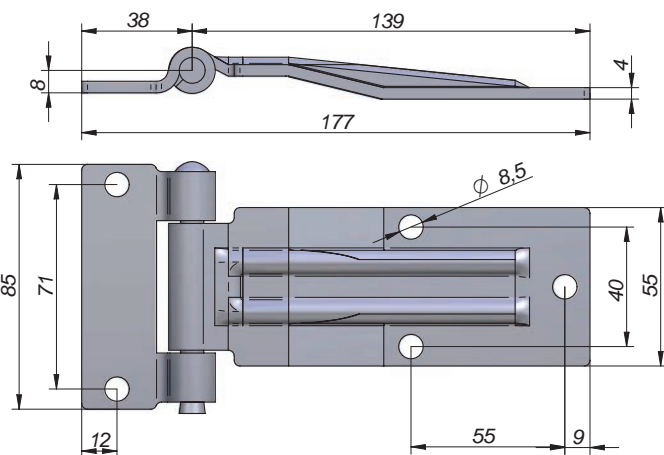
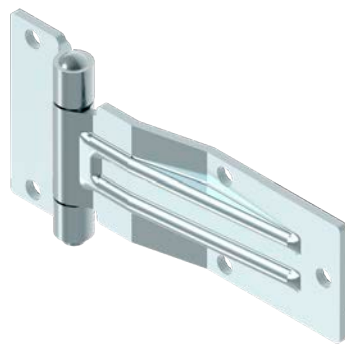

Strap Hinge
Seitentürscharnier gesickt
Bisagra Lateral de Libro

Ref	Kg	Mat	Sup/Finish Acabado	Thickn. Espesor	Lot
1303034	0.49	STEEL	Zn	3	1
1303244	0.49	INOX		3	1

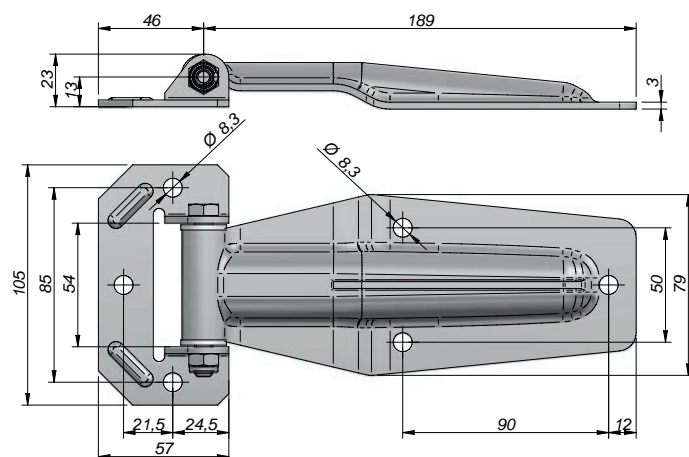
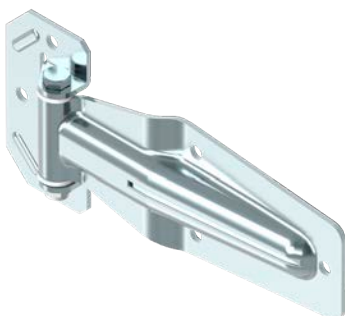

Side Hinge Plane Stainless Steel
Seitentürscharnier Glatt Edelstahl
Bisagra Lateral Lisa inox

Ref	Kg	Mat	Thickn. Espesor	Lot
1303238	0.3	INOX	3	2

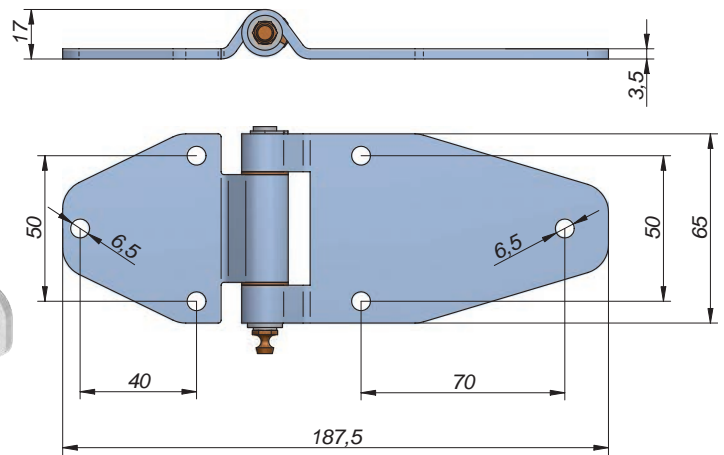

Side Hinge Plane Stainless Steel
Seitentürscharnier Glatt Edelstahl
Bisagra Lateral Lisa Inox

Ref	Kg	Mat	Thickn. Espesor	Lot
1303240	0.54	INOX	4	2

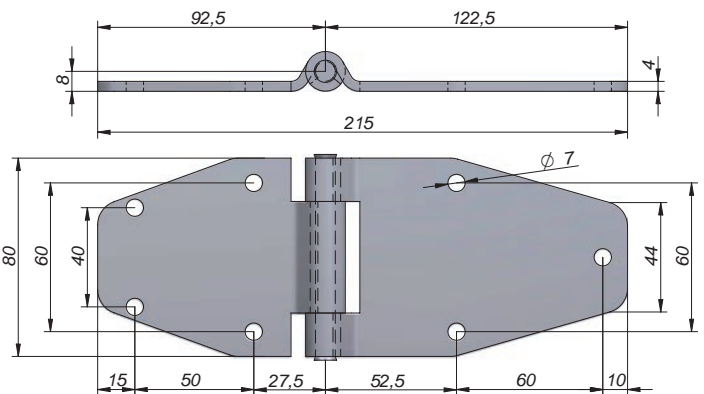
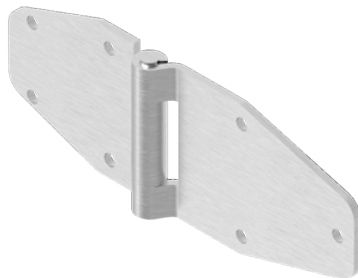

Side Hinge Plane Stainless Steel
Seitentürscharnier Glatt Edelstahl
Bisagra Lateral Lisa Inox

Ref	Kg	Mat	Thickn. Espesor	Lot
1303242	0.31	INOX	4	2

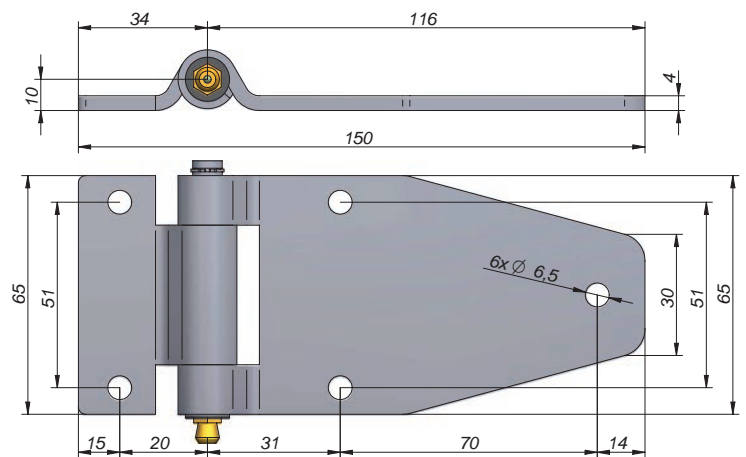
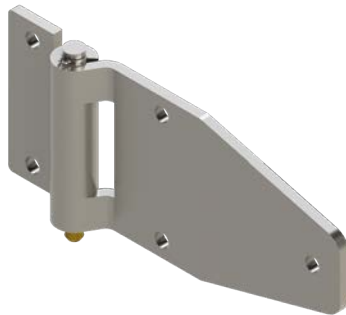

Side Hinge
Seitentürscharnier Glatt
Bisagra Lateral Lisa

Ref	Kg	Mat	Sup/Finish Acabado	Thickn. Espesor	Lot
1303046	0.19	STEEL	Zn	4	10
1303261	0.2	INOX		4	4

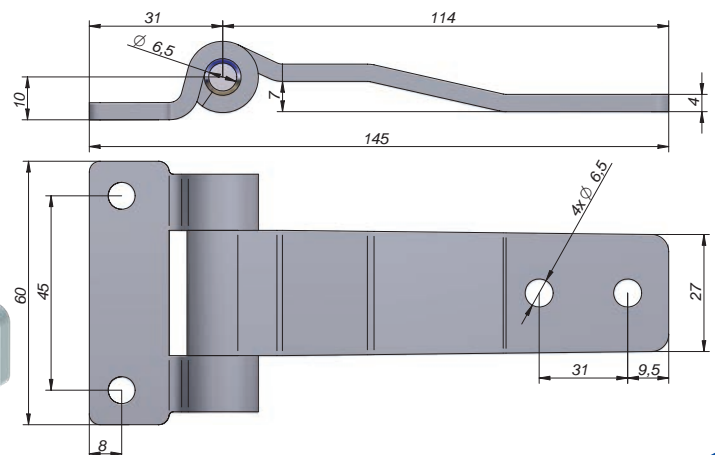
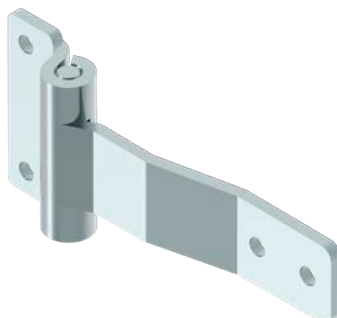



SIDE HINGE / SEITENTÜRSCHARNIERE / BISAGRA LATERAL

HINGES / SCHARNIERE / BISAGRAS

Side Hinge flat-polished
Seitentürscharnier flach-glatt
Bisagra Lateral Plana-Lisa

Ref	Kg	Mat	Sup/Finish Acabado	Thickn. Espesor	Lot
1303056	0.19	STEEL	Zn	4	10
1303281	0.2	INOX		4	2

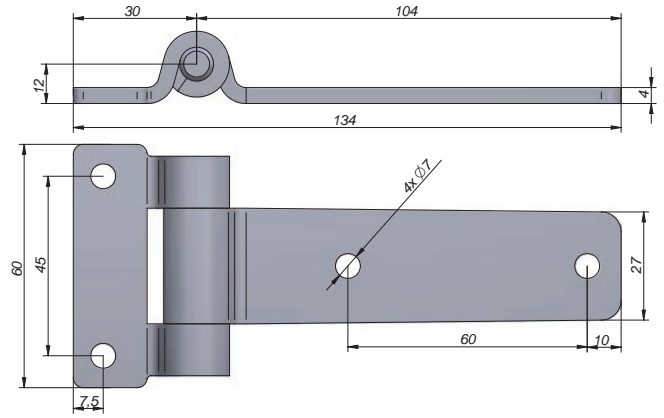
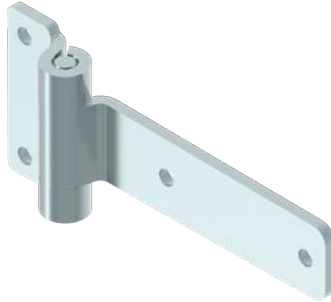

Side Hinge Plane Nerve Stainless Steel
Seitentürscharnier Glatt-gesickt Edelstahl
Bisagra Lateral Nervio Inox

Ref	Kg	Mat	Thickn. Espesor	Lot
1303250	0.14	INOX	3	2

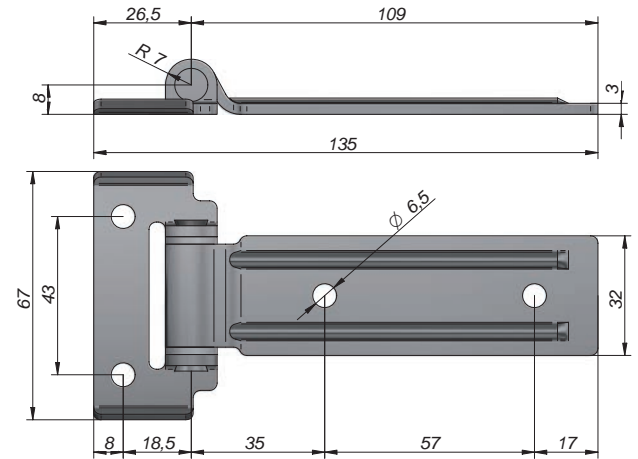

Side Hinge Plane Stainless Steel
Seitentürscharnier Glatt Edelstahl
Bisagra Lateral Lisa Inox

Ref	Kg	Mat	Thickn. Espesor	Lot
1303205	0.05	INOX	2	2

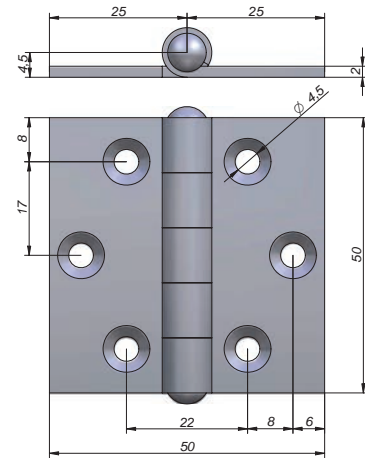

Complete Hinge (28 mm.)
Tür-Scharnierband (28 mm.)
Bisagra Continua (28 mm.)

Ref	Kg	Mat	A	B	C	Lot
1303340	3.42		2,4 m.	190	170	1
1303350	3.82		2,7 m.	120	140	1

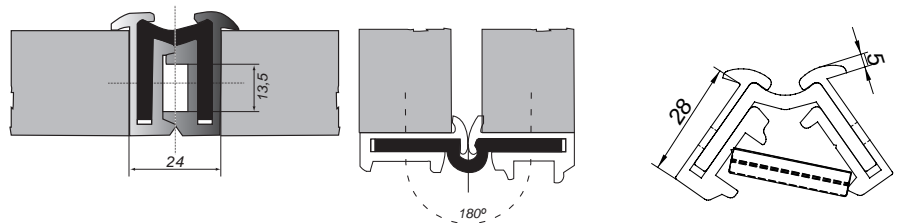

Dimensiones de los agujeros lado derecho
Right side hole dimensions

Vista desde arriba
Top view

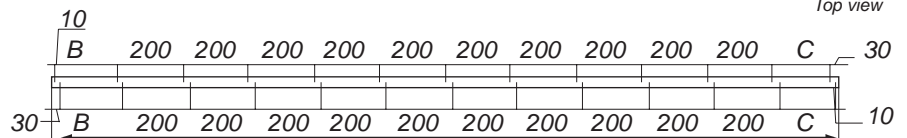

Dimensiones de los agujeros lado izquierdo
Left side hole dimensions

Piano Hinge Ø4 mm.
 Klavier-Scharnierband Ø4 mm.
 Bisagra Piano Ø4 mm.

Ref	Kg	Mat	A	B	C	D	Article	Lot
1303351	2.35	INOX	2000	33	1980	10	AISI201	1
1303352	2.35	INOX	2000	33	1980	10	AISI304	1
1303354	2.94	INOX	2500	41	2460	20	AISI304	1
1303355	2.94	INOX	2500	41	2460	20	AISI201	1
1303362	2.7	INOX	2300	38	2280	10	AISI201	1

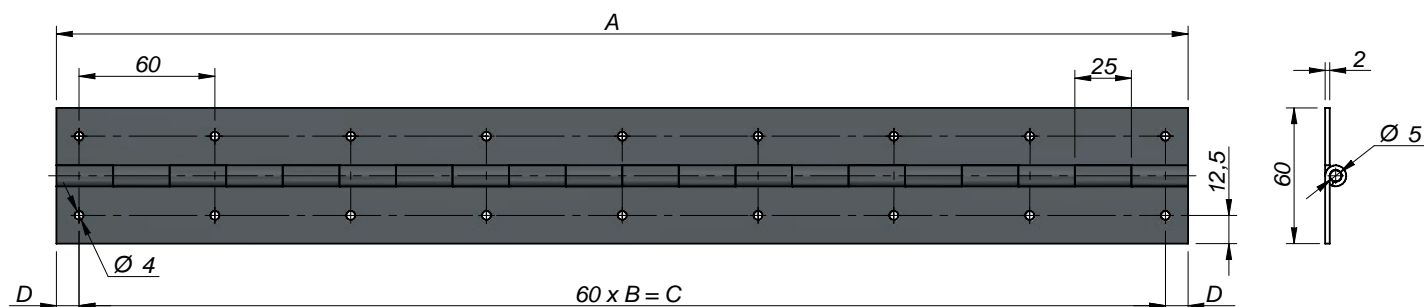
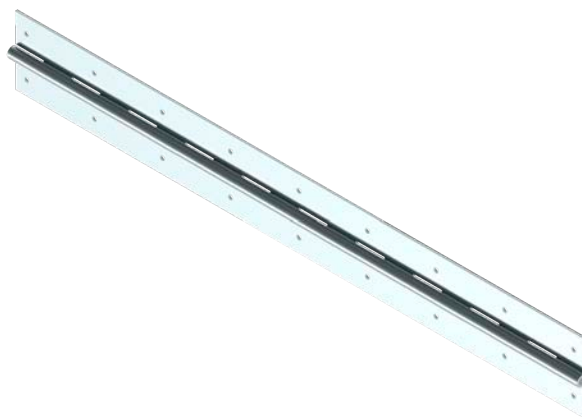

$B = N^{\circ}$ Agujeros / N_{Holes}

Stainless Steel Piano Hinge Ø5 mm.
 Klavier-Scharnierband Edelstahl Ø5 mm.
 Bisagra Piano Acero Inoxidable Ø5 mm.

Ref	Kg	Mat	A	B	C	D	Article	Lot
1303359	2.94	INOX	2300	19	2280	10	AISI201	1

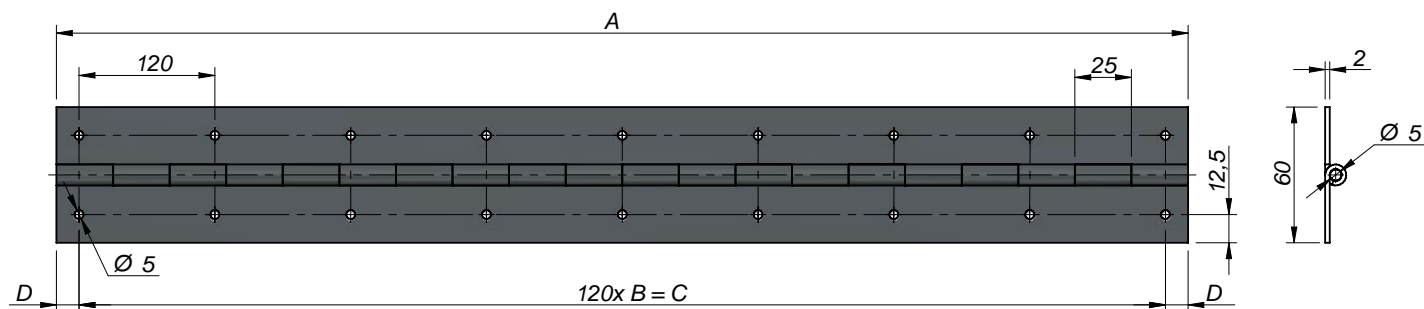

$B = N^{\circ}$ Agujeros / N_{Holes}



FORGED HINGES / SCHARNIERE GESCHMIEDET / BISAGRAS DE FORJA

HINGES / SCHARNIERE / BISAGRAS

Male Plane Ø12
Scharnierbolzen Ø12
Macho Liso Ø12

Ref	Kg	Mat	Ø	Lot
1306005	0.16	Forged	12	4

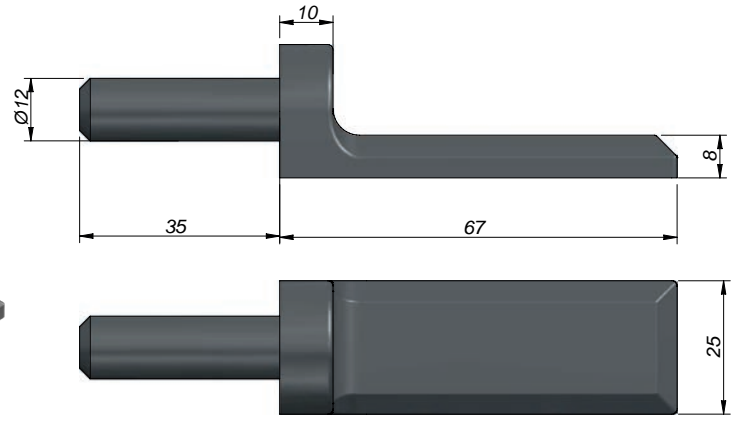
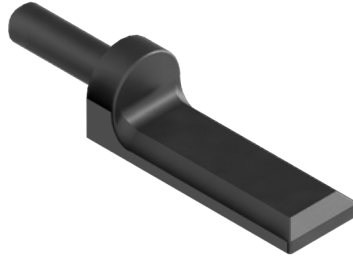

Male Plane Ø14
Scharnierbolzen Ø14
Macho Liso Ø14

Ref	Kg	Mat	Ø	Lot
1306004	0.26	Forged	14	10

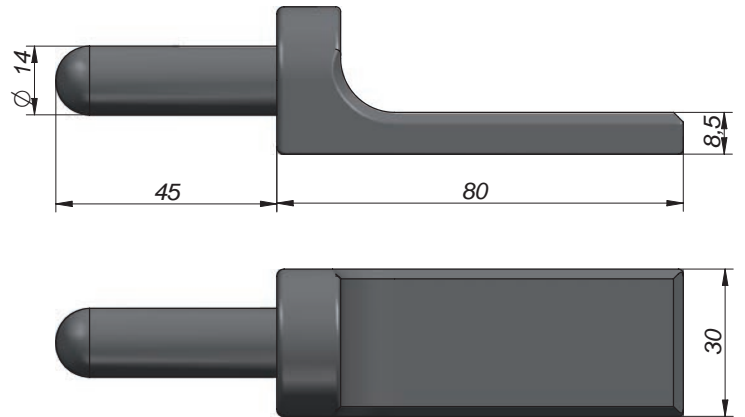
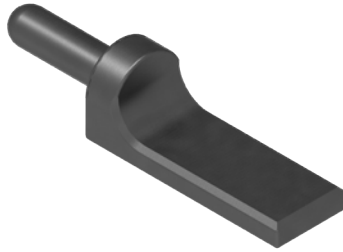

Female Plane (Ø14,5)
Scharnier (Ø14,5)
Hembra Lisa (Ø14,5)

Ref	Kg	Mat	Ø	Lot
1306104	0.31	Forged	14.5	2

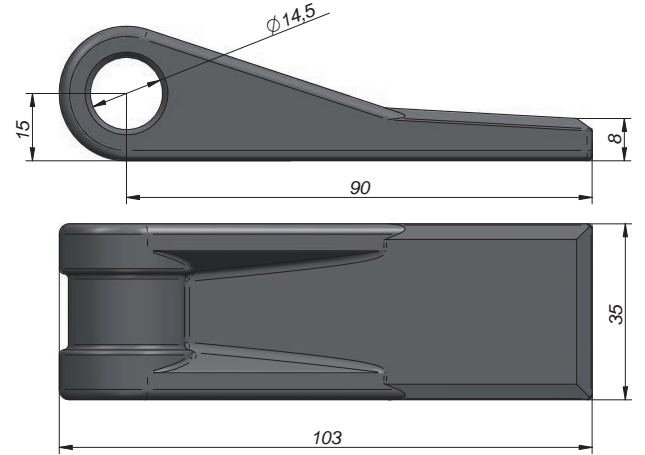

Female Plane (Ø16,5)
Scharnier (Ø16,5)
Hembra Lisa (Ø16,5)

Ref	Kg	Mat	Ø	Lot
1306102	0.44	Forged	16.5	2

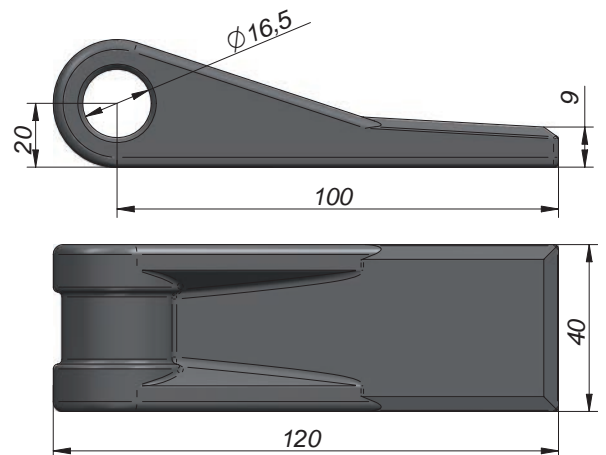

Male Plane Ø20
Scharnierbolzen Ø20
Macho Liso Ø20

Ref	Kg	Mat	Ø	Lot
1306090	0.65	Forged	20	20

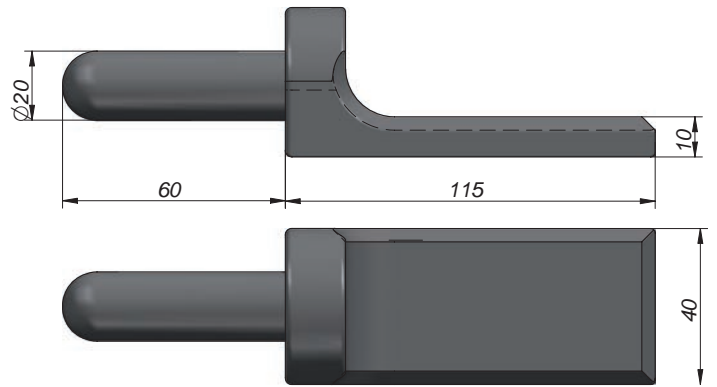
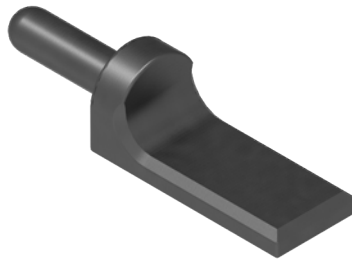

Drop Forged Steel Ø19
Fahnenangel, Gesenkstahl Ø19
Gozne Ø19 Forja

NEW

Ref	Kg	Mat	Ø	Lot
1306008	1.41	Forged	19	1

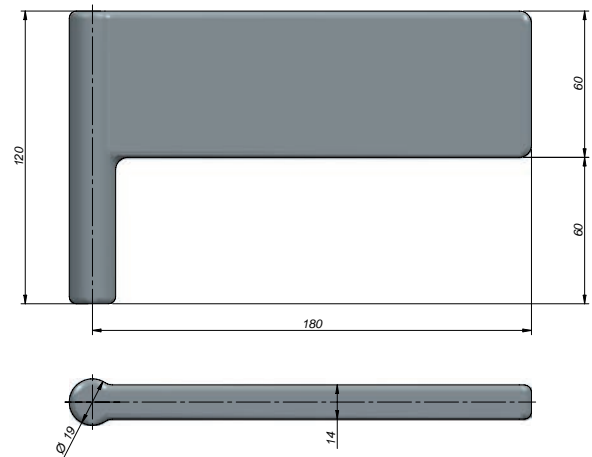
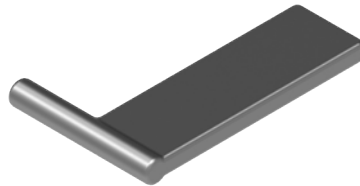

Female Plane (Ø20) with grease nipple
Scharnier (Ø20) mit Schmiernippel
Hembra Lisa (Ø20) c/Engrasador

Ref	Kg	Mat	Ø	Lot
1306190	0.6	Forged	20	20

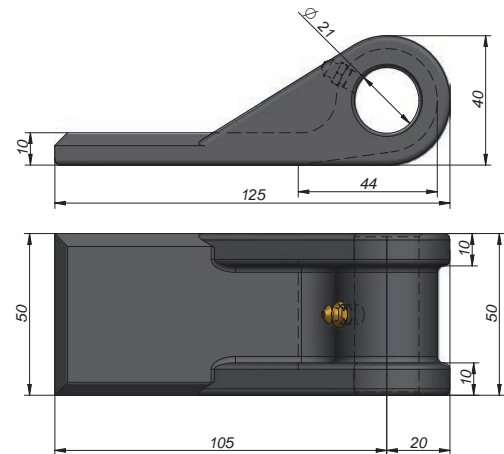

Male Nerve Ø15
Scharnierbolzen Ø15
Macho Nervio Ø15

Ref	Kg	Mat	Ø	Lot
1306020	0.24	Forged	15	2

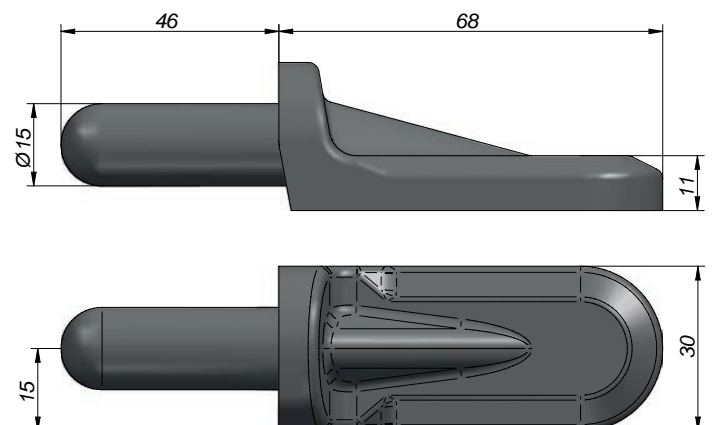
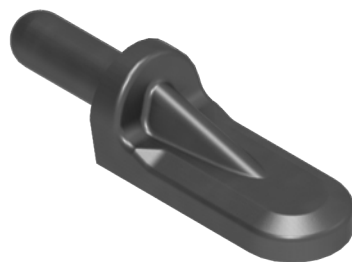



FORGED HINGES / SCHARNIERE GESCHMIEDET / BISAGRAS DE FORJA

HINGES / SCHARNIERE / BISAGRAS

Female Plane (Ø16,5)
Scharnier (Ø16,5)
Hembra Lisa (Ø16,5)

Ref	Kg	Mat	Ø	Lot
1306130	0.28	Forged	16.5	4

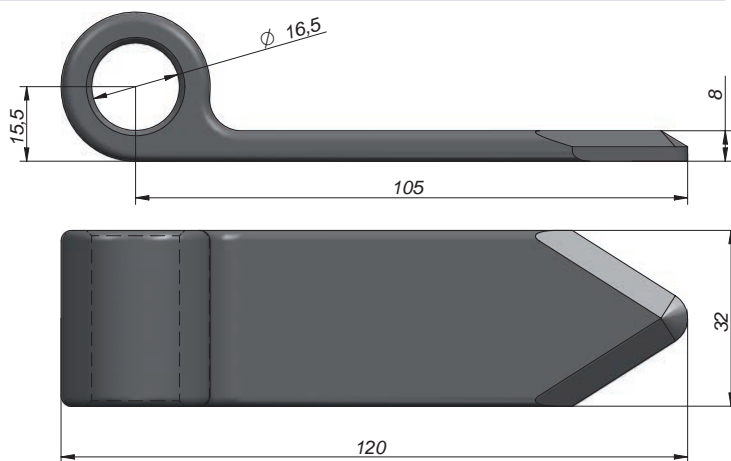

Female Plane (Ø16)
Scharnier (Ø16)
Hembra Lisa (Ø16)

Ref	Kg	Mat	Ø	Lot
1306140	0.23	Forged	16	2

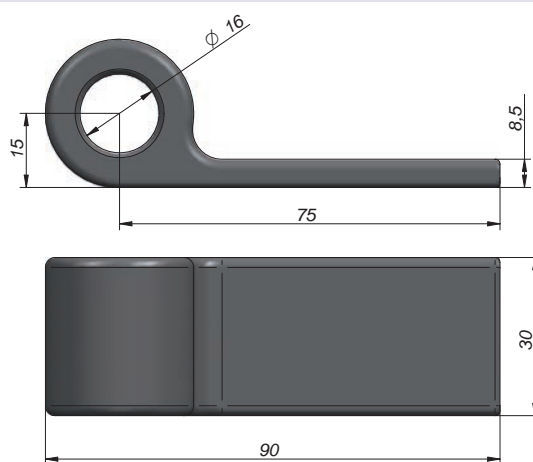
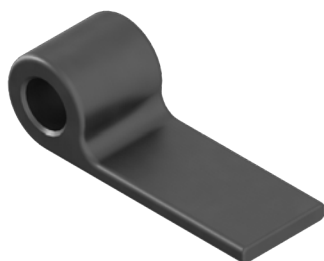

Male Nerve Ø16,5
Scharnierbolzen Ø16,5
Macho Nervio Ø16,5

Ref	Kg	Mat	Ø	Lot
1306010	0.34	Forged	16.5	4

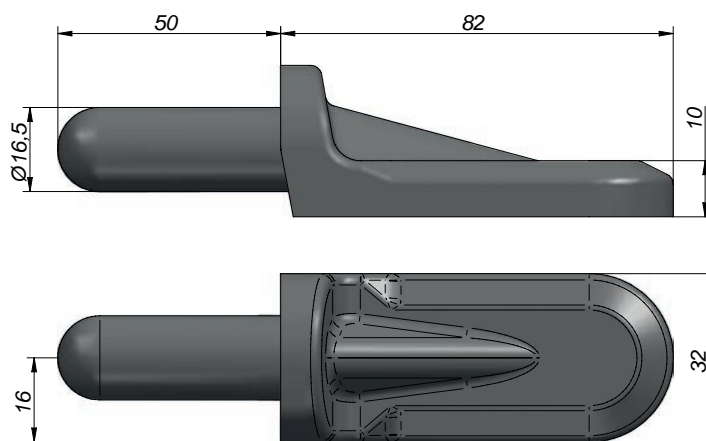

Female Nerve (Ø18)
Scharnier (Ø18) Gekröpft
Hembra Nervio (Ø18)

Ref	Kg	Mat	Ø	Lot
1306120	0.38	Forged	18	5

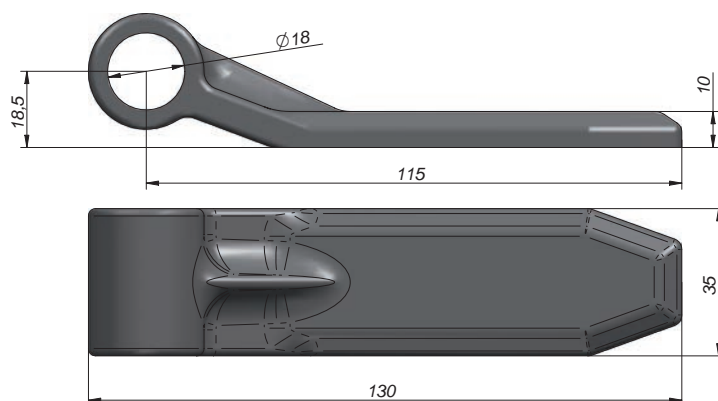

Female Nerve (Ø18)
Scharnier (Ø18) Gekröpft
Hembra Nervio (Ø18)

Ref	Kg	Mat	Sup/Finish Acabado	Ø	Lot
1306180	0.8	Forged	Zn	18	3

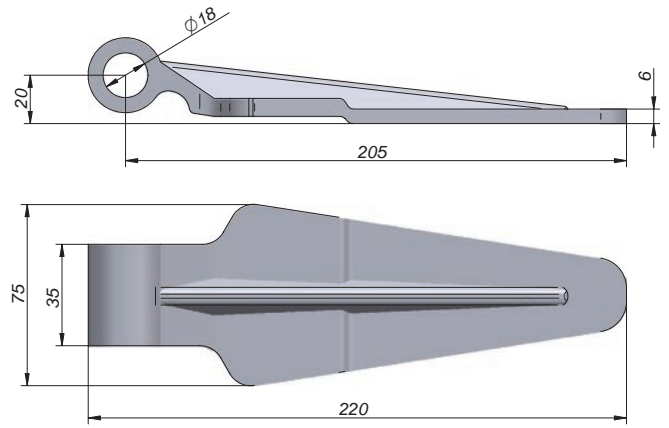
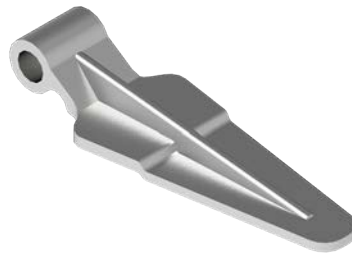

Female Nerve (Ø28)
Scharnier Geschmiedet (Ø28)
Hembra Contenedor Nervio (Ø28)

Ref	Kg	Mat	Ø	Lot
1306184	1.55	Forged	28	1

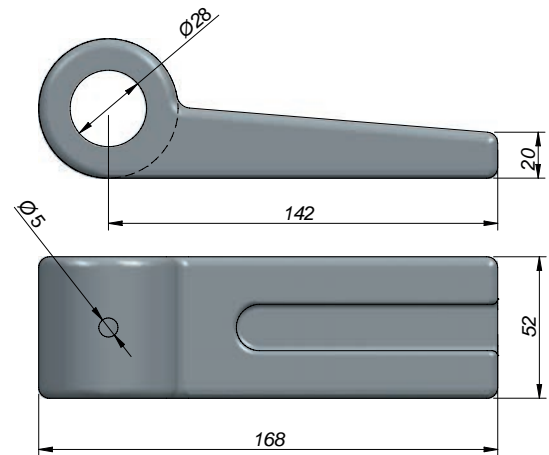

Female Nerve (Ø22)
Scharnier Geschmiedet (Ø22) Gekröpft
Hembra Contenedor Nervio (Ø22)

Ref	Kg	Mat	Ø	Lot
1306186	1.14	Forged	28	1

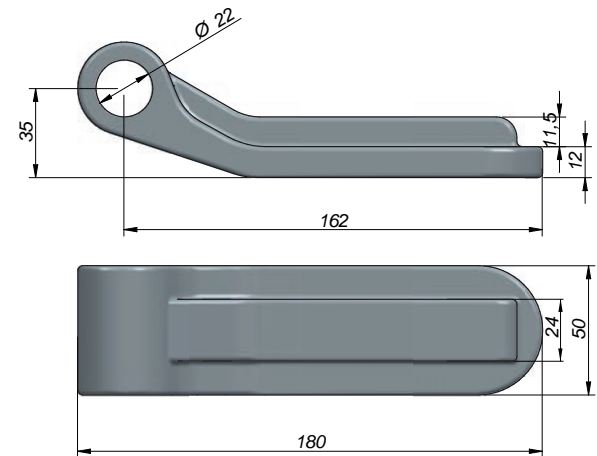

Female Nerve (Ø20)
Scharnier (Ø20) Gekröpft
Hembra Nervio (Ø20)

Ref	Kg	Mat	Ø	Lot
1306110	0.63	Forged	20	2

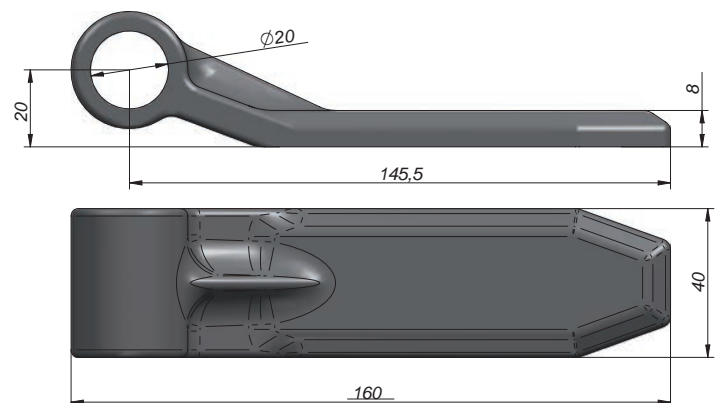



FORGED HINGES / SCHARNIERE GESCHMIEDET / BISAGRAS DE FORJA

HINGES / SCHARNIERE / BISAGRAS

Small Bolt (Ø17)
Schieberiegelverschluss Klein (Ø17)
Cerrojo Pequeño (Ø17)

Ref	Kg	Mat	Ø	Lot
1201250	0.78	Forged	17	2

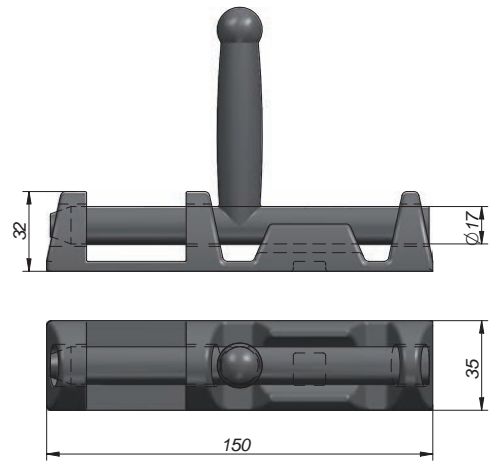
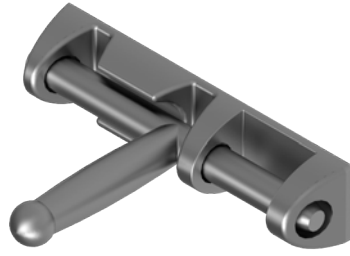

Big Bolt (Ø19)
Schieberiegelverschluss Gross (Ø19)
Cerrojo Grande (Ø19)

Ref	Kg	Mat	Ø	Lot
1201245	1.25	Forged	19	1

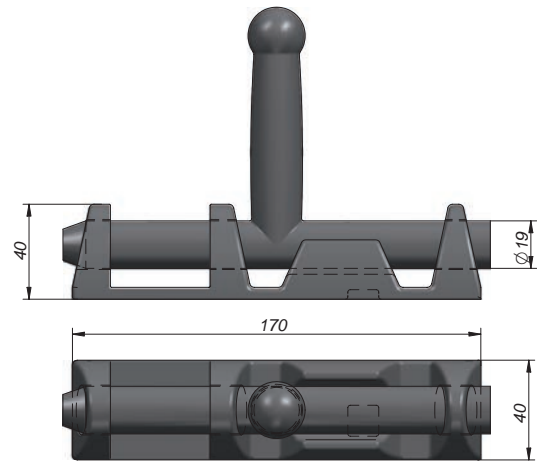
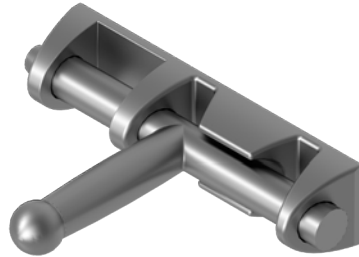

Perfiles

Profiles

Profils

Profile

Perfis



Perfiles de Cartola
Side Board Profiles
Ridelles
Stecklattenprofile
Perfis de Painel

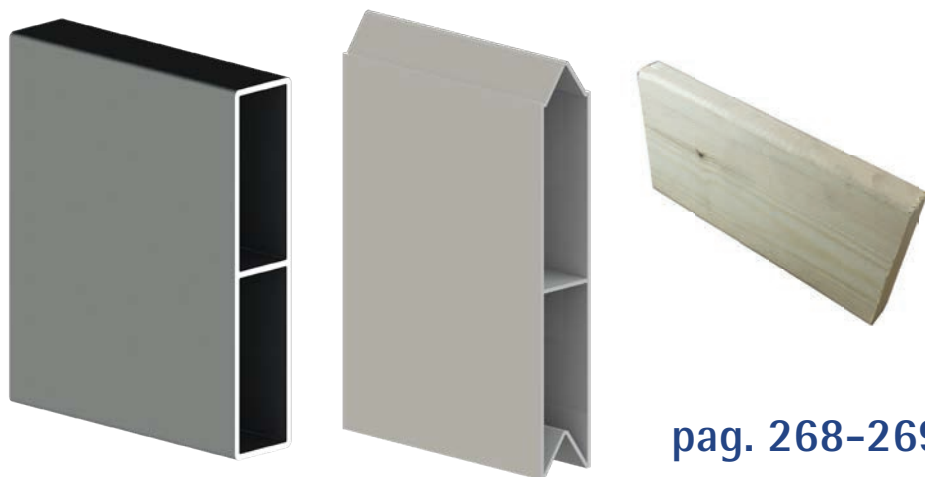

pag. 268-269

Perfiles Lona y Techo
Curtain / Roof Profiles
Profil Bâche
Planen / Dachprofile
Perfis Lona e Teto



pag. 270-273

Perfiles de Puerta
Door Profiles
Profil de Porte
Türdichtprofile
Perfis de Porta

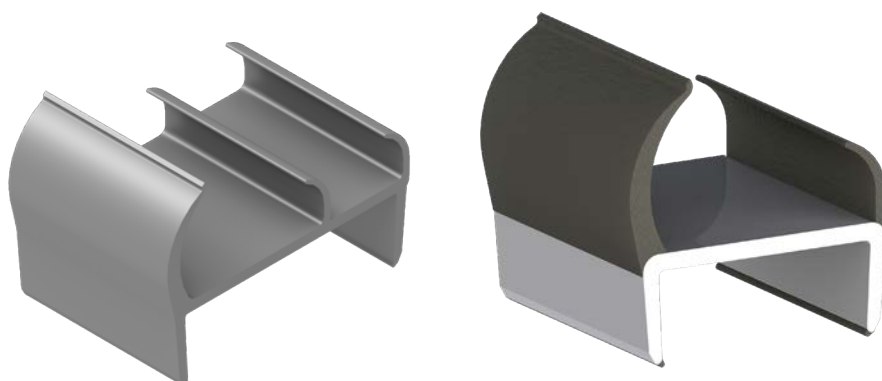

pag. 274-276



SIDE BOARD PROFILES / STECKLATTENPROFILE / PERFILES DE CARTOLA

PROFILES / PROFILE / PERFILES

Aluminium Side Plank Profile 120x25
Aluminium Einstecklatte 120x25
Barra Perfil Cartola 120x25 Aluminio

Ref	Kg	Mat	A	Lot
1402091	3.54		3,25m.	2

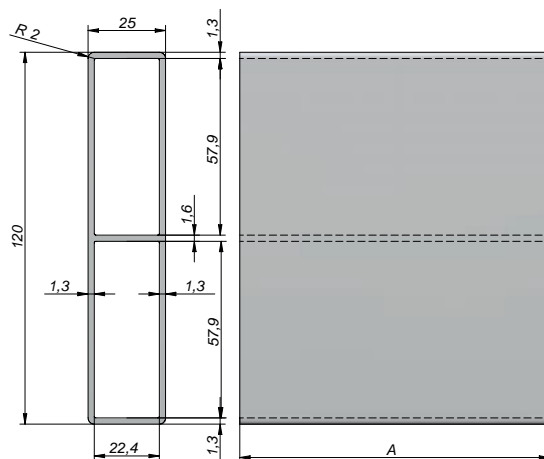
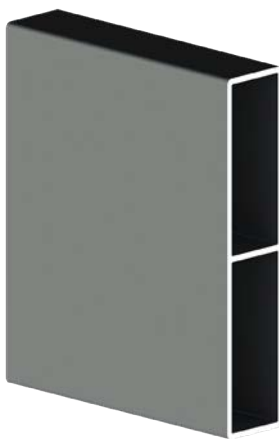

Plastic Cap 120x25
Endkappe Kunststoff 120x25 für Alu-Stecklatte
Tapón Perfil de Cartola 120x25

Ref	Kg	Mat	Pack
1402210	0.12		4

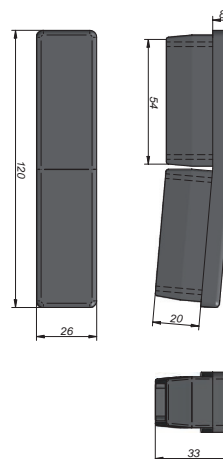

Aluminium Slip-on Plank Profile 140x25
Aluminium Einstecklatte 140x25
Barra Perfil Apilable 140x25 Aluminio

Ref	Kg	Mat	A	Lot
1402101	4.36		3,25m.	2

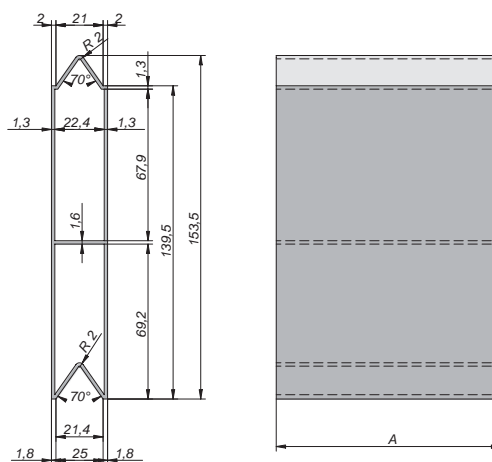

Aluminium Slip-on Plank Profile 110x25
Aluminium Einstecklatte 110x25
Barra Perfil Apilable 110x25 Aluminio

NEW

Ref	Kg	Mat	A	Lot
1402104	3.12		3,25m.	2

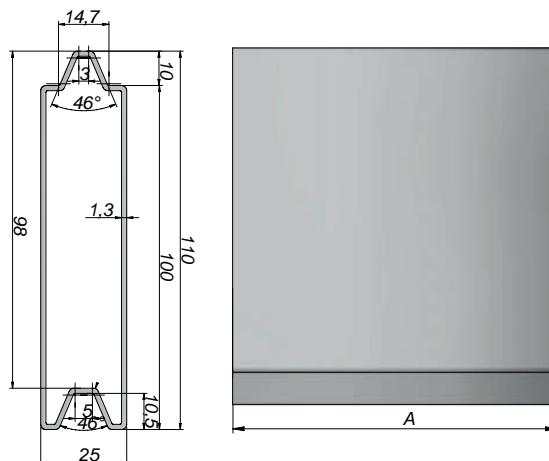
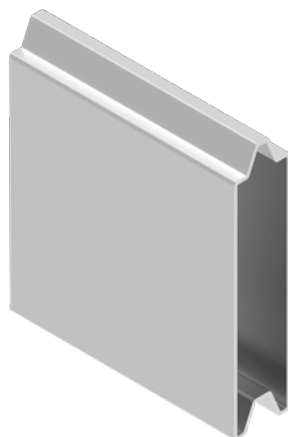



Wooden Plug-in Lath 120x25
 Holzstecklatten Holz 120x25
 Tabla Baranda Pino Cepillado 120x25

Ref	Kg	Mat	A	B	C	Article	Lot
1402080	4.64		2,7m.	120	25		6
1402082	5.67		3,3m.	120	25		6
1402083 NEW	5.67		3,3m.	120	25	Phytosanitary Mark NIMF-15 con Tratamiento fitosanitario NIMF-15	6

Brushed pine wood (rounded polishing). Density at 12% from H (Kg./m3): 500-520-540. Hardness: Soft / semi-hard. Hardness coefficient: 2
 Gebürstete Kiefer (poliert, abgerundet) | Dichte bei 12% H. (kg / m3): 500-520-540 | Härte: Weich-Mittel Hart | Härteoeffizient: 2

PROFILES / PROFILE / PERFILES

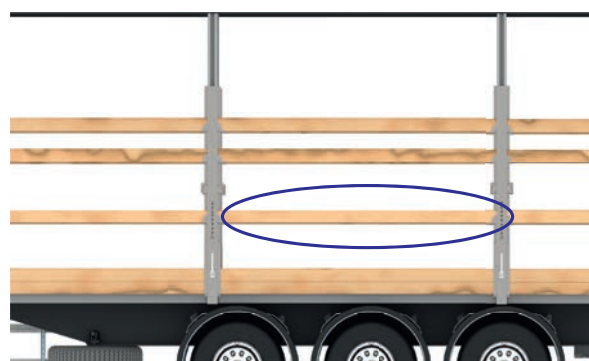
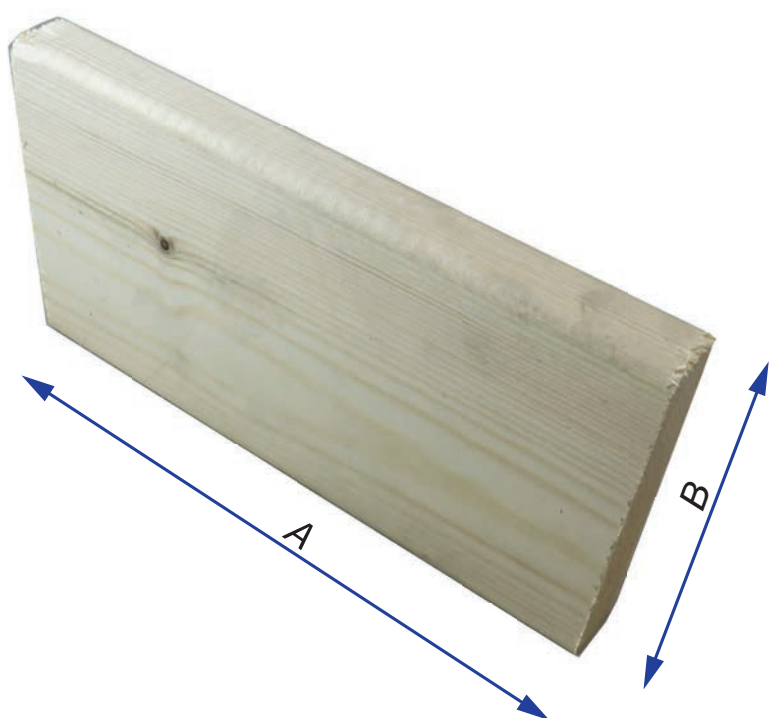

CURTAIN AND ROOF PROFILES / PLANEN-,DACH- & LAUFSCHIENENPROFILE / PERFILES DE LONA Y TECHO

PROFILES / PROFILE / PERFILES

Horizontal Aluminium Rail Profile ADA-SLIDER
Laufschieneprofil Aluminium Horizontal ADA-SLIDER
Perfil Horizontal ADA-SLIDER Aluminio

Ref	Kg	Mat	Pos	A	Lot
1402412	5.64	Al	↔	3m.	2
1402410	7.52	Al	↔	4m.	2
1402408	9.4	Al	↔	5m.	2
1402406	11.27	Al	↔	6m.	2
1402404	13.15	Al	↔	7m.	

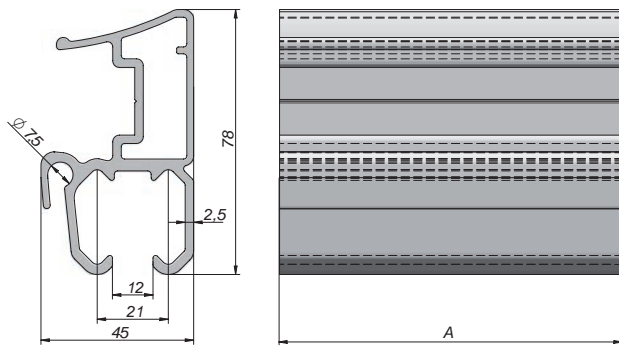

Vertical Aluminium Profile ADA-SLIDER
Türprofil Vertikal Aluminium ADA-SLIDER
Perfil Vertical ADA-SLIDER Aluminio

Ref	Kg	Mat	Pos	A	Lot
1402427	7.49	Al	↕	2,1m.	2
1402429	8.56	Al	↕	2,4m.	2
1402431	9.98	Al	↕	2,8m.	2

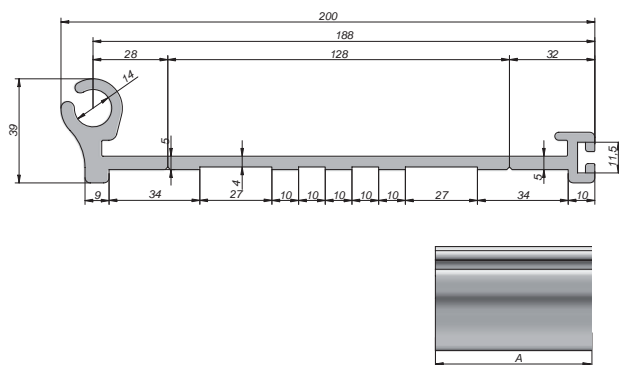

Curtain Profile, Aluminium
Scheibepanprofil, Aluminium
Perfil de Lona Aluminio

Ref	Kg	Mat	A	Lot
1402440	14.34	Al	7m.	2

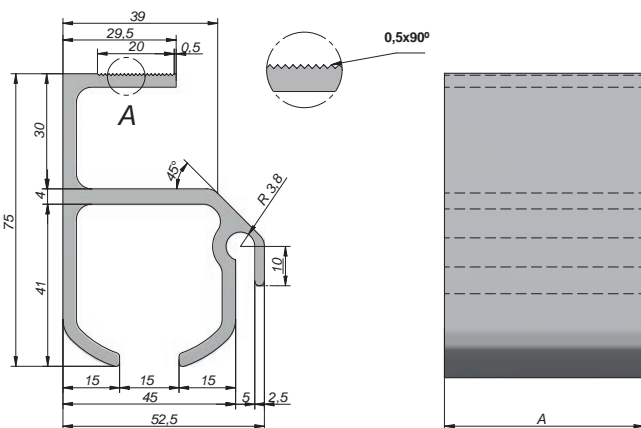
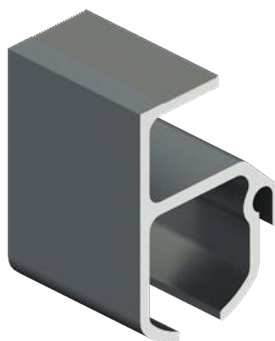

Galvanized Steel Bar Profile
Laufschieneprofil Stahl feuerverzinkt
Perfil Acero Galvanizado para goma

Ref	Kg	Mat	Sup/Finish Acabado	A	Thickn. Espesor	Lot
1403010	20.55	STEEL	Galv	7m.	2	1
1403012	22.9	STEEL	Galv	7,8m.	2	1
1490006 NEW	16.15	STEEL	Galv	5,5m.	2	1

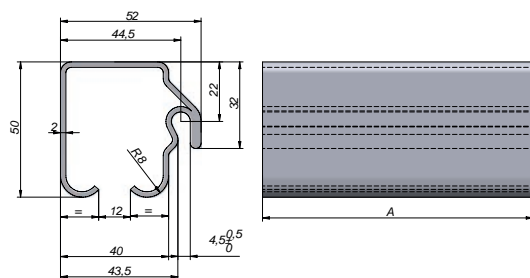

CURTAIN AND ROOF PROFILES / PLANEN-,DACH- & LAUSCHIENENPROFILE / PERFILES DE LONA Y TECHO

Galvanized Steel Bar Profile
 Laufschienenprofil Stahl feuerverzinkt
 Perfil Acero Galvanizado

Ref	Kg	Mat	Sup/Finish Acabado	A	Thickn. Espesor	Lot
1403020	17.6	STEEL	Galv	7m.	2	1
1403018	19	STEEL	Galv	7,8m.	2	1

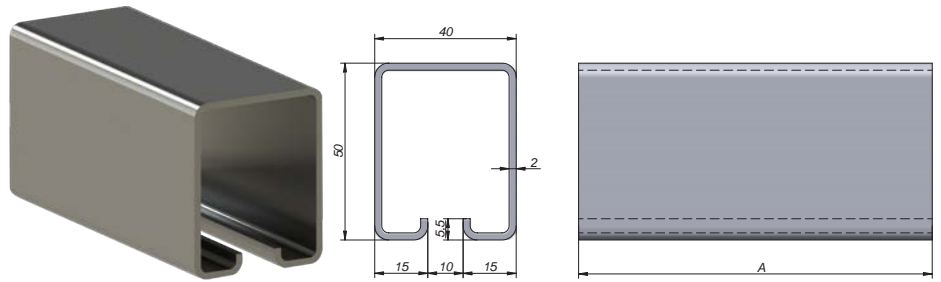

Galvanized Steel Bar Profile
 Laufschienenprofil Stahl feuerverzinkt
 Perfil Acero Galvanizado

Ref	Kg	Mat	Sup/Finish Acabado	A	Thickn. Espesor	Lot
1403030	9.9	STEEL	Galv	7m.	1.5	1

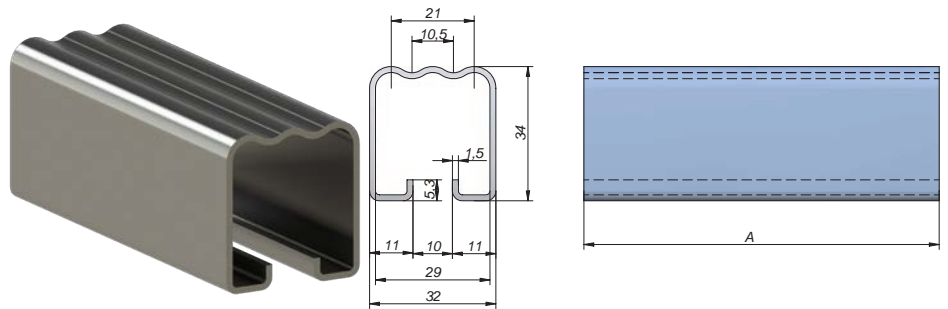

Curtain Profile Aluminium
 Planeneinhakprofil Aluminium
 Perfil Lona Aluminio

Ref	Kg	Mat	A	Lot
1402511	2.84	Al	3m.	2
1402512	3.12	Al	3,3m.	2

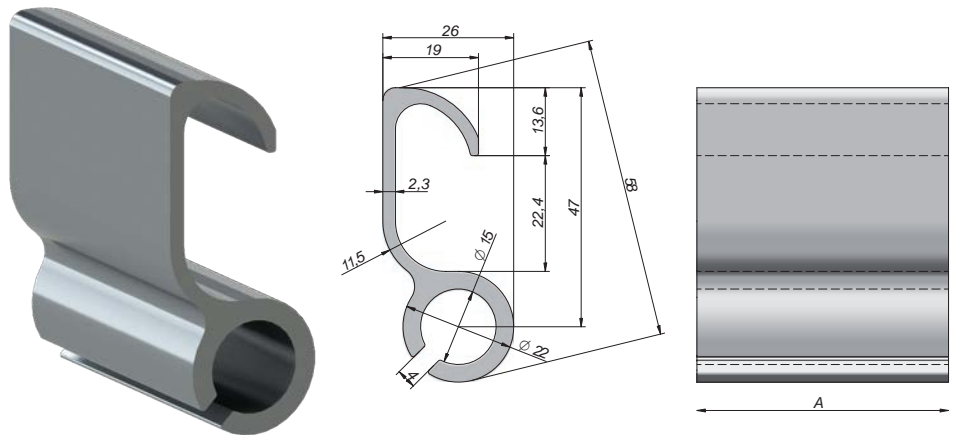

Curtain Profile Aluminium
 Planeneinhakprofil Aluminium
 Perfil Lona Aluminio

Ref	Kg	Mat	A	Lot
1402505	5.21	Al	3m.	2

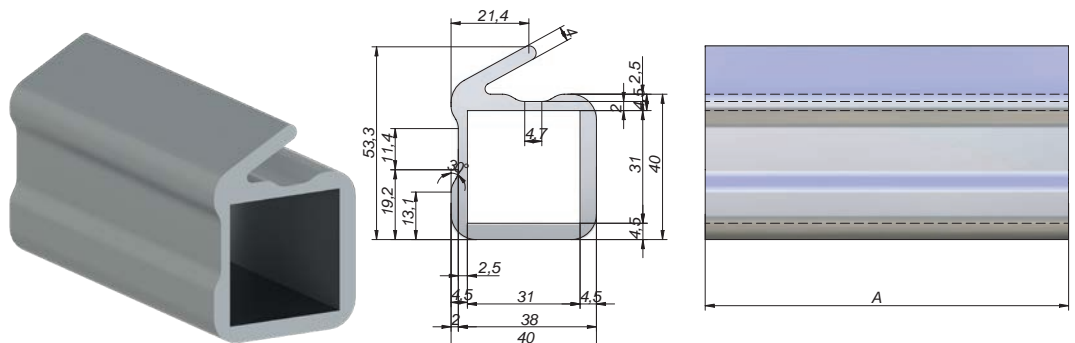



CURTAIN AND ROOF PROFILES / PLANEN-,DACH- & LAUFSCHIENENPROFILE / PERFILES DE LONA Y TECHO

PROFILES / PROFILE / PERFILES

Curtain Profile Aluminium
Planenein的角度 Aluminium
Perfil Lona Aluminio

Ref	Kg	Mat	A	Lot
1402517	1.38		2,55m.	1

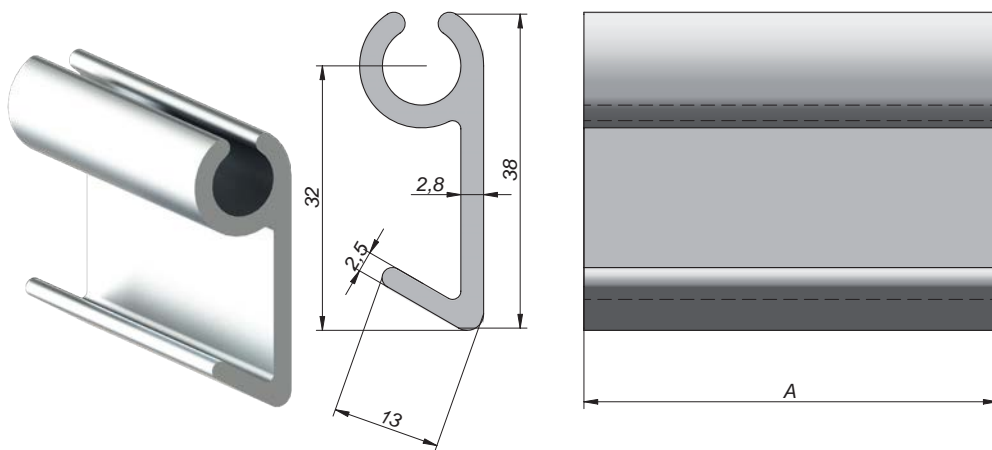

Curtain Profile Aluminium
Planenein的角度 Aluminium
Perfil Lona Aluminio

Ref	Kg	Mat	A	Lot
1402519	2.51		3m.	2

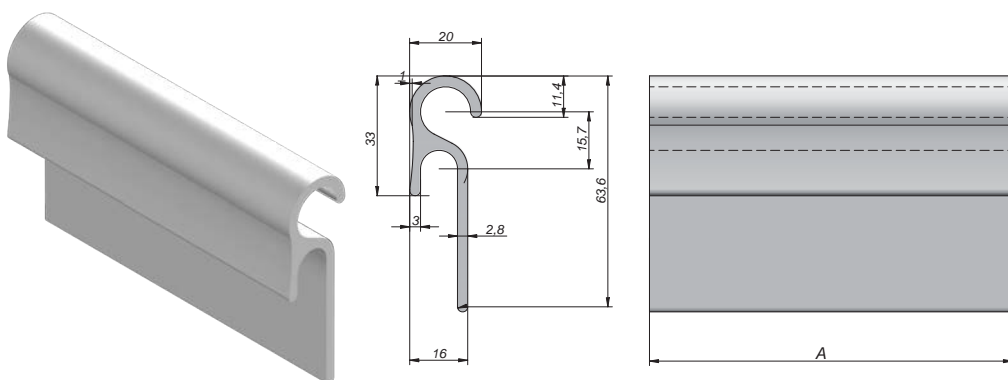

Profile Roll Exterior PVC
PVC Dichtlippenprofil
Rollo Perfil Exterior PVC

Ref	Kg	Mat	Col	A	Thickn. Espesor	Lot
1404170	7.43			14m.	4	1
1404172	7.43			14m.	4	1
1404174	39.2			56m.	4	1
1404177	39.5			56m.	4	1

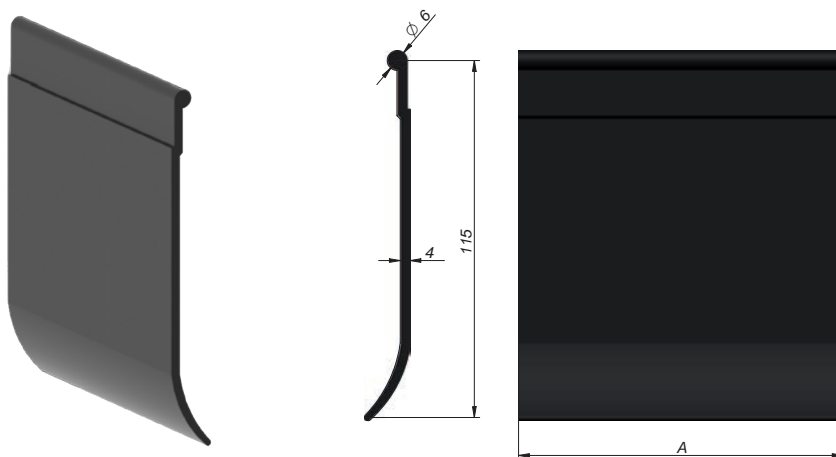

Interior Profile PVC Roll
PVC Dichtlippenprofil, Schwarz
Rollo Perfil Interior PVC

Ref	Kg	Mat	Col	A	Thickn. Espesor	Lot
1404190	9.1			14m.	4	1
1404187	39.3			56m.	4	1

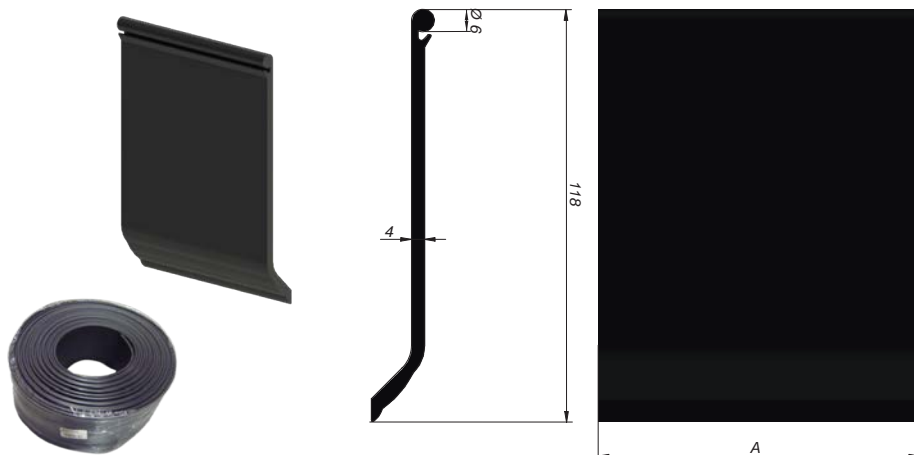

CURTAIN AND ROOF PROFILES / PLANEN-,DACH- & LAUFSCHIENENPROFILE / PERFILES DE LONA Y TECHO

ADA-SLIDER Profile Roll PVC Vertical
 Türdicht-Profil ADA-SLIDER PVC Vertikal
 Rollo Perfil PVC Vertical ADA-SLIDER

Ref	Kg	Mat	Col	Pos	A	Thickn. Espesor	Lot
1404202	1.77				10m.	4	1

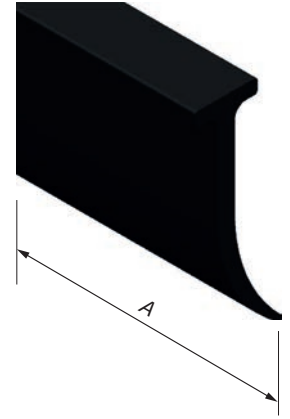
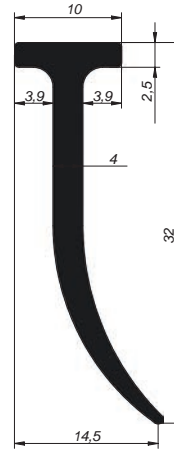

PROFILES / PROFILE / PERFILES

Outfolding Roll
 Rollband
 Rollo Fleje

Ref	Kg	Mat	Col	A	B	Thickn. Espesor	Lot
1404181	2.25			50m.	20	2.5	1
1404180	15			100m.	63	2.5	1

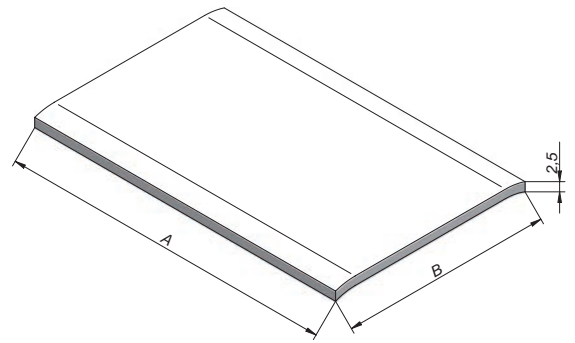



DOORS PROFILES / TÜRDICHTPROFILE / PERFILES DE PUERTA

PROFILES / PROFILE / PERFILES

Bar Profile PVC
Türdichtprofil PVC, 2-lippig
Perfil PVC

Ref	Kg	Mat	A	B	C	D	E	Lot
1401058	1.23		2,8m.	20	26	18	15	1
1401059	1.32		3m.	20	26	18	15	1
1401048	1.12		2,8m.	25	26	21	15	1
1401049	1.2		3m.	25	26	21	15	1
1401042	1.18		2,8m.	30	36	20	15	1
1401041	1.26		3m.	30	36	20	15	1
1401034	1.23		2,8m.	35	33	20	15	1
1401028	1.23		2,8m.	40	36	18	20	1
1401029	1.32		3m.	40	36	18	20	1

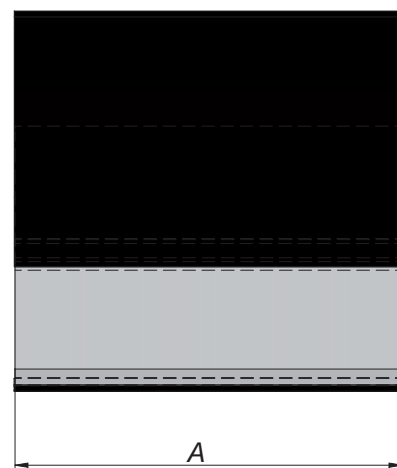
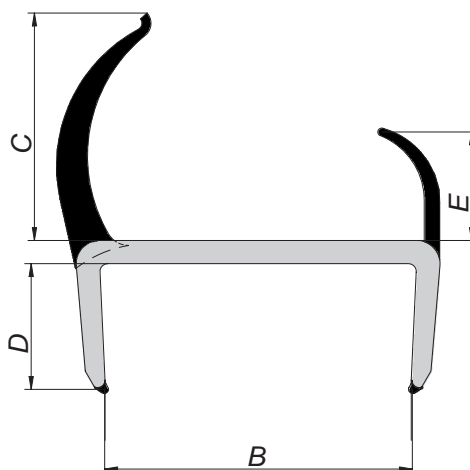

Bar Profile PVC
Türdichtprofil PVC, 3-lippig
Perfil Puerta PVC

Ref	Kg	Mat	Col	A	B	C	D	E	Lot
1401024	2.07			3m.	64	66.7	72.7	20	8
1401014	2.67			3m.	83	85.5	91.5	25	6

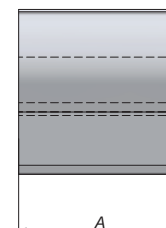
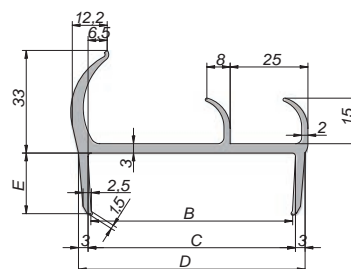
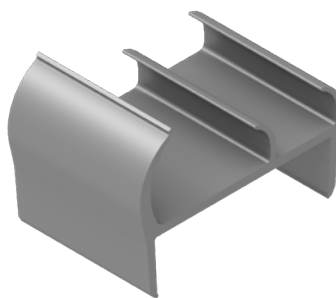

Bar Profile PVC Black-Grey
Türdichtprofil PVC, 3-lippig Schwarzgrau
Perfil Puerta PVC Negro-Gris

Ref	Kg	Mat	Col	A	Lot
1401070	1.88			2,8m.	1

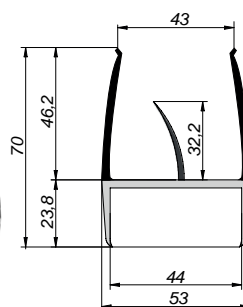

Bar Profile PVC Grey-Grey
Türdichtprofil PVC ,3-lippig Grau-Grau
Perfil Puerta PVC Gris-Gris

Ref	Kg	Col	A	Lot
1492002	1.88		2,7m.	1

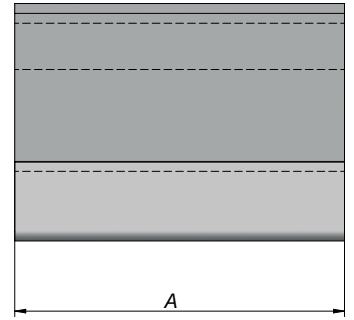
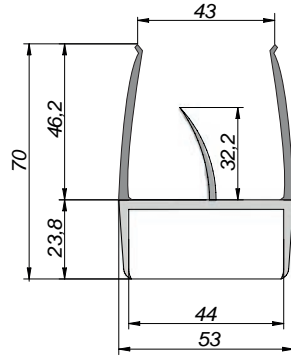
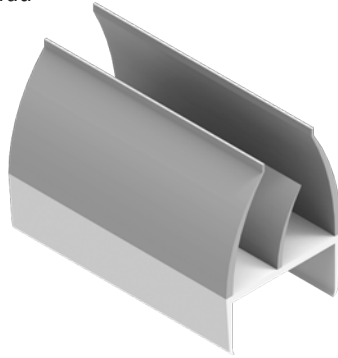

Bar Profile PVC Black-Grey Co-extruded
Türdichtprofil PVC Schwarzgrau coextrudiert
Perfil Puerta PVC Negro-Gris Co-extruido

Ref	Kg	Mat	Col	A	Lot
1401071	2.08			2,8m.	1

Ideal for refrigerated truck
Ideal para camión refrigerado

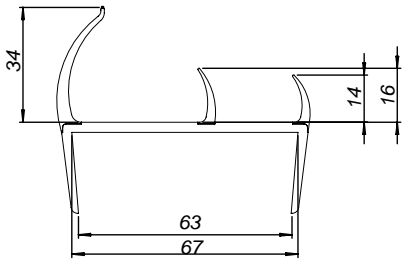
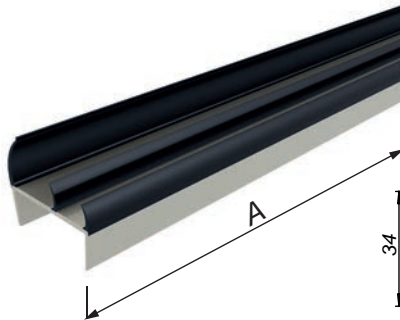

Angle for Door Profile 1401071
Angle für Profil 1401071
Angulo para Perfil Puerta 1401071

NEW

Ref	Kg	Mat	Col	Lot	Pack
1401090	0.2			1	20

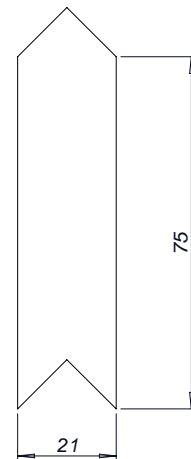

Bar Profile PVC Black Co-extruded
Türdichtprofil PVC Schwarz coextrudiert
Perfil Puerta PVC Negro Co-extruido

Ref	Kg	Mat	Col	A	Lot
1401073	3.14			2,8m.	1

Ideal for refrigerated truck
Ideal para camión refrigerado

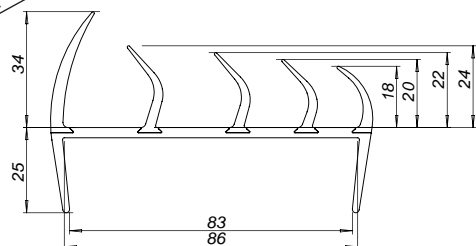
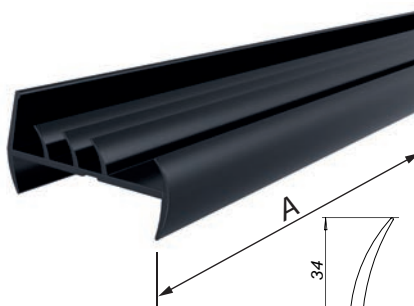



Bar Profile PVC Black Co-extruded
Türdichtprofil PVC Schwarz coextrudiert
Perfil Puerta PVC Negro Co-extruido

NEW

Ref	Kg	Mat	Col	A	Lot
1401075	1.96			2,8m.	1

Ideal for refrigerated truck
Ideal para camión refrigerado

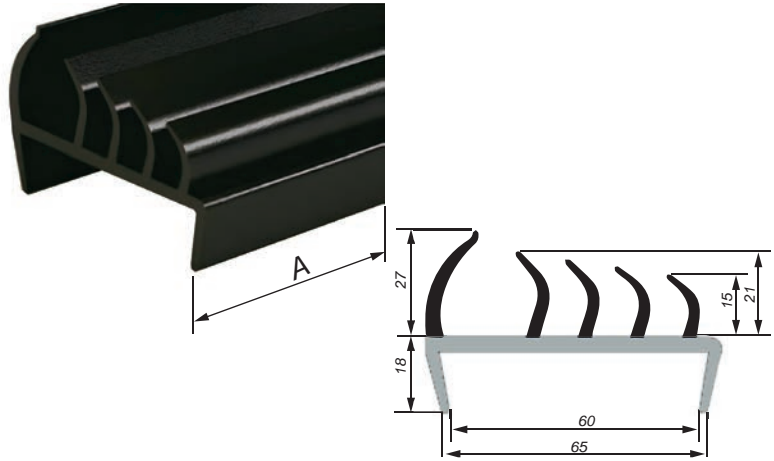

Bar Profile PVC Black-Grey Co-extruded
Türdichtprofil PVC Schwarzgrau coextrudiert
Perfil Puerta PVC Negro-Gris Co-extruido

NEW

Ref	Kg	Mat	Col	A	Lot
1401082	1.12			2,8m.	1

Ideal for rear and lateral doors
Ideal para puertas traseras y laterales

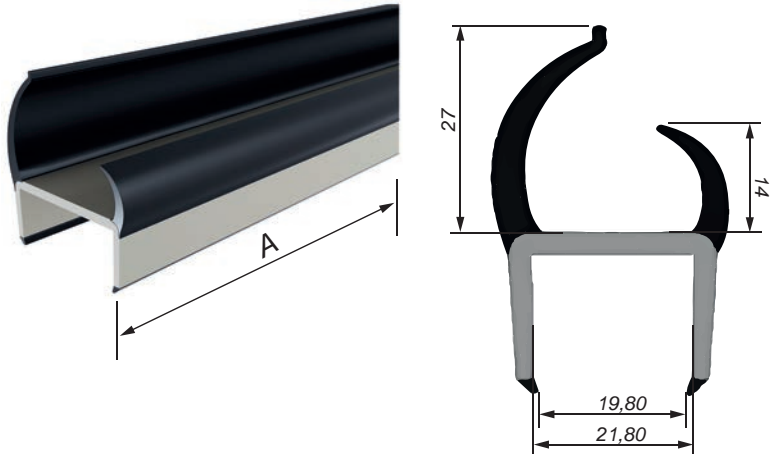

Bar Profile PVC Black-Grey Co-extruded
Türdichtprofil PVC Schwarzgrau coextrudiert
Perfil Puerta PVC Negro-Gris Co-extruido

Ref	Kg	Mat	Col	A	Lot
1401084	1.26			2,8m.	1

Ideal for rear and lateral doors
Ideal para puertas traseras y laterales

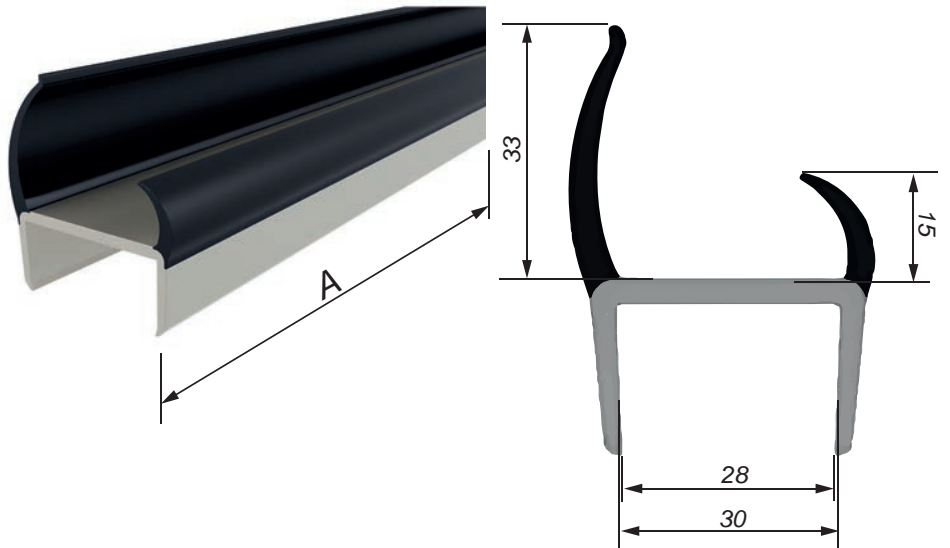

Suministros Industriales
Industrial Supplies
Fournitures Industrielles
Industriebedarf
Suplementos Industriais

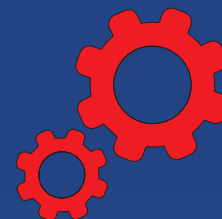

Remaches
Rivets
Rivets
Nieten
Rebites



pag. 278-294

Tornillería
Bolts
Boulons
Schrauben
Parafusos



pag. 295-296

Discos
Discs
Disques
Scheiben
Discos



pag. 297-302

Máquina Y Accesorios
Machines And Acces.
Machines Et Accessoires
Maschinen Und Zubehör
Máquinas E Acessórios



pag. 303-315

Químicos
Chemicals
Produits Chimiques
Chemiestreifen
Químicos



pag. 316-317

Soldadura
Welding
Accessoires De Soudure
Schweissen
Soldadura



pag. 318

ADARIVETS

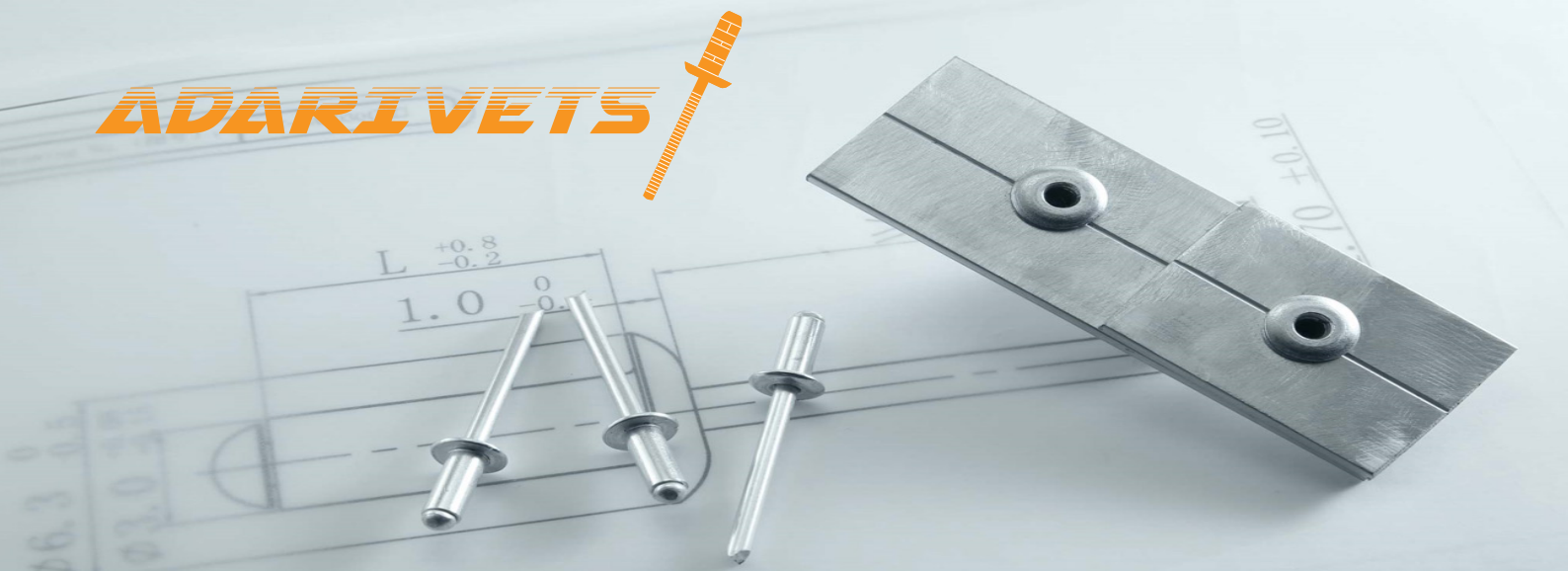

NEW



BENEFITS / VENTAJAS

- ✓ Efficient and safe fastening.
Sujeción eficaz y segura.
- ✓ Standard & structural rivets.
Remaches estándar y estructurales.
- ✓ Rivet nuts.
Tuercas remachables.
- ✓ Fine finishing.
Acabados finos.
- ✓ Multiple applications for the Commercial Vehicle.
Múltiples aplicaciones para Vehículo Industrial.
- ✓ Cordless, pneumatic and manual Rivet Tools.
Remachadoras a batería, neumáticas y manuales.
- ✓ ADAICO QUALITY guaranteed.
Calidad garantizada por ADAICO.





Dome Head Aluminium/Steel
 Flachrundkopf Aluminium/Stahl
 Cabeza Alomada Aluminio/Acero

NEW

Ref	Kg	Mat	Ø	A	B	C	D	E	F	Thickn. Espesor	Pack
2803008	0.9		3.0	8	3,5-5,5	6.3	Ø3,1	800	500	1	1000
2804806	1.1		4.8	6	1,5-2,5	9.7	Ø4,9	2230	1690	1.2	500
2804808	1.15		4.8	8	2,5-4,0	9.7	Ø4,9	2230	1690	1.2	500
2804810	1.25		4.8	10	4,0-6,0	9.7	Ø4,9	2230	1690	1.2	500
2804812	1.3		4.8	12	6,0-8,0	9.7	Ø4,9	2230	1690	1.2	500
2804814	1.5		4.8	14	8,0-10,0	9.7	Ø4,9	2230	1690	1.2	500
2804816	1.45		4.8	16	10,0-12,0	9.7	Ø4,9	2230	1690	1.2	500
2804818	1.55		4.8	18	12,0-14,0	9.7	Ø4,9	2230	1690	1.2	500
2804820	1.5		4.8	20	14,0-16,0	9.7	Ø4,9	2230	1690	1.2	500
2804920	0.75		4.8	20	14,0-16,0	9.7	Ø4,9	2230	1690	1.2	250
2804822	0.83		4.8	22	16,0-18,0	9.7	Ø4,9	2230	1690	1.2	250
2804825	0.9		4.8	25	17,0-21,0	9.7	Ø4,9	2230	1690	1.2	250
2804828	1.08		4.8	28	20,0-23,0	9.7	Ø4,9	2230	1690	1.2	250
2804830	1.2		4.8	30	23,0-25,0	9.7	Ø4,9	2230	1690	1.2	250
2804835	1.1		4.8	35	25,0-30,0	9.7	Ø4,9	2230	1690	1.2	250
2804840	1.15		4.8	40	30,0-35,0	9.7	Ø4,9	2230	1690	1.2	250
2804845	1.1		4.8	45	35,0-39,0	9.7	Ø4,9	2230	1690	1.2	200
2804850	1.15		4.8	50	39,0-44,0	9.7	Ø4,9	2230	1690	1.2	200
2804855	0.5		4.8	55	44,0-49,0	9.7	Ø4,9	2230	1690	1.2	100
2804860	0.97		4.8	60	49,0-54,0	9.7	Ø4,9	2230	1690	1.2	150
2806010	1.15		6.0	10	3,0-5,0	12	Ø6,1	3900	3000	1.9	250
2806012	1.17		6.0	12	5,0-7,0	12	Ø6,1	3900	3000	1.9	250
2806014	1.21		6.0	14	7,0-9,0	12	Ø6,1	3900	3000	1.9	250
2806016	1.23		6.0	16	9,0-11,0	12	Ø6,1	3900	3000	1.9	250
2806018	1.33		6.0	18	11,0-13,0	12	Ø6,1	3900	3000	1.9	250
2806020	1.4		6.0	20	13,0-15,0	12	Ø6,1	3900	3000	1.9	250
2806022	1.48		6.0	22	15,0-17,0	12	Ø6,1	3900	3000	1.9	250
2806026	1.25		6.0	26	18,0-20,0	12	Ø6,1	3900	3000	1.9	200
2806030	1.35		6.0	30	19,0-24,0	12	Ø6,1	3900	3000	1.9	200
2806412	1.4		6.4	12	3,0-6,0	13	Ø6,5	4090	3120	2.2	250
2806422	1.5		6.4	22	14,0-16,0	13	Ø6,5	4090	3120	2.2	250
2806430	1.5		6.4	30	19,0-23,0	13	Ø6,5	4090	3120	2.2	200
2806415	1.5		6.4	15	7,0-9,0	13	Ø6,5	4090	3120	2.2	250
2806418	1.55		6.4	18	10,0-12,0	13	Ø6,5	4090	3120	2.2	250
2806426	1.5		6.4	26	18,0-19,0	13	Ø6,5	4090	3120	2.2	200

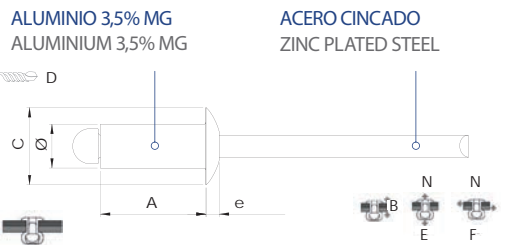

INDUSTRIAL SUPPLIES / INDUSTRIEBEDARF / SUMINISTROS INDUSTRIALES

STANDARD RIVET / STANDARD NIETE / REMACHE STANDARD

INDUSTRIAL SUPPLIES / INDUSTRIEBEDARF / SUMINISTROS INDUSTRIALES

Dome Head Aluminium/Steel Painted
Flachrundkopf Aluminium/Stahl Lackiert
Cabeza Alomada Alu/Acero Lacado

NEW

Ref	Kg	Mat	Col	Ø	A	B	C	D	E	F	Thickn. Espesor	Pack
2803412	2.48			4.0	12	6,5-8,5	8	Ø4,1	1600	1300	1.3	500
2803418	2.48			4.0	18	12,5-14,5	8	Ø4,1	1600	1300	1.3	500

Ref	Kg	Mat	Col	Ø	A	B	C	D	E	F	Thickn. Espesor	Pack
2803512	2.48			4.8	12	6,0-8,0	9.5	Ø4,9	2230	1690	1.4	500
2803516	1.45			4.8	16	10,0-12,0	9.5	Ø4,9	2230	1690	1.4	500

RAL9003
UNE-EN ISO 14589/15977

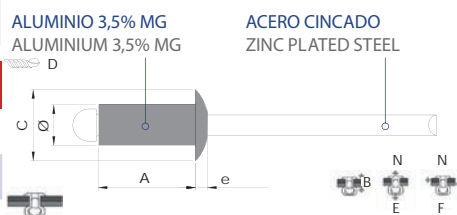

Countersunk Head Aluminium/Steel
Senkkopf Aluminium/Stahl
Cabeza Avellanada Aluminio/Acero

NEW

Ref	Kg	Mat	Ø	A	B	C	D	E	F	Pack
2802520	3.18		4.8	20	14,0-16,0	9	Ø4,9	2230	1690	500

Application: flat or preformed metal sheets or plates, thickness ≥ 1 mm | Do not combine soft elements | Body-shank tightness
Aplicación: chapas o placas de metal preformadas o planas, espesores ≥ 1 mm | No combinar elementos blandos | Estanqueidad cuerpo-vástago
UNE-EN ISO 14589/15983

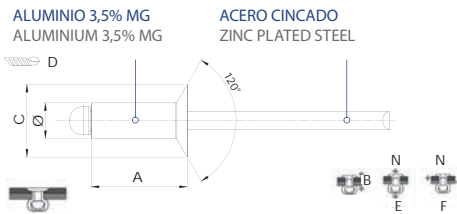

Flat Head Aluminium/Steel
Flachkopf Aluminium/Stahl
Cabeza Ancha Aluminio/Acero

NEW

Ref	Kg	Mat	Ø	A	B	C	D	E	F	Thickn. Espesor	Pack
2814010	0.9		4.0	10	5,0-6,5	12	Ø4,1	1600	1200	1.5	500

Ref	Kg	Mat	Ø	A	B	C	D	E	F	Thickn. Espesor	Pack
2814808	0.6		4.8	8	2,5-4,0	14	Ø4,9	2230	1690	1.8	250
2814810	0.7		4.8	10	4,5-6,0	14	Ø4,9	2230	1690	1.8	250
2814812	0.7		4.8	12	6,0-8,0	14	Ø4,9	2230	1690	1.8	250
2814814	0.75		4.8	14	8,0-10,0	14	Ø4,9	2230	1690	1.8	250
2814816	0.8		4.8	16	10,0-12,0	14	Ø4,9	2230	1690	1.8	250
2814818	0.85		4.8	18	12,0-14,0	14	Ø4,9	2230	1690	1.8	250
2814820	0.9		4.8	20	14,0-16,0	14	Ø4,9	2230	1690	1.8	250
2814824	0.95		4.8	24	18,0-21,0	14	Ø4,9	2230	1690	1.8	250
2814828	0.95		4.8	28	21,0-23,0	14	Ø4,9	2230	1690	1.8	250
2814830	0.76		4.8	30	23,0-25,0	14	Ø4,9	2230	1690	1.8	200
2814835	0.85		4.8	35	25,0-30,0	14	Ø4,9	2230	1690	1.8	200

Ref	Kg	Mat	Ø	A	B	C	D	E	F	Thickn. Espesor	Pack
2816016	1.1		6.0	16	10,0-12,0	18	Ø6,1	3900	3000	2.1	250

Application: flat or preformed metal sheets or plates, thickness ≥ 1 mm | Do not combine soft elements | Body-shank tightness
Aplicación: chapas o placas de metal preformadas o planas, espesores ≥ 1 mm | No combinar elementos blandos | Estanqueidad cuerpo-vástago

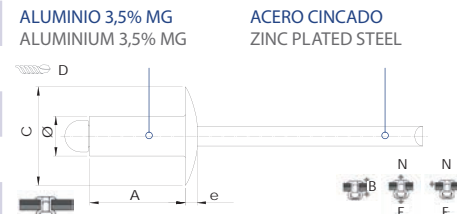

Flat Head Aluminium/Steel White Painted
 Flachkopf Aluminium/Stahl Lackiert Weiss
 Cabeza Ancha Aluminio/Acero Lacado Blanco

NEW

Ref	Kg	Mat	Col	Ø	A	B	C	D	E	F	Thickn. Espesor	Pack
2811416	0.8			4.8	16	10,0-12,0	14	Ø4,9	2230	1690	1.8	250



ALUMINIO 3,5% MG
ALUMINIUM 3,5% MG

ACERO CINCADO
ZINC PLATED STEEL

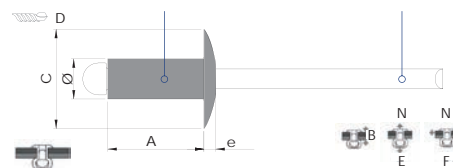

Flat Head Aluminium/Steel Black Painted
 Flachkopf Aluminium/Stahl Lackiert Schwarz
 Cabeza Ancha Aluminio/Acero Lacado Negro

NEW

Ref	Kg	Mat	Col	Ø	A	B	C	D	E	F	Thickn. Espesor	Pack
2812518	1.67			4.8	18	12,0-14,0	14	Ø4,9	2230	1690	1.8	500



ALUMINIO 3,5% MG
ALUMINIUM 3,5% MG

ACERO CINCADO
ZINC PLATED STEEL

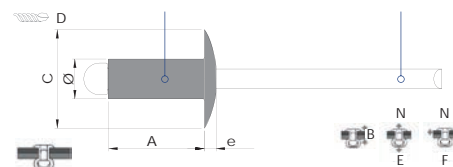

ExtraFlat Head Aluminium/Steel
 ExtraFlachkopf Aluminium/Stahl
 Cabeza ExtraAncha Aluminio/Acero

NEW

Ref	Kg	Mat	Ø	A	B	C	D	E	F	Thickn. Espesor	Pack
2815014	0.81		4.8	14	8,0-10,0	16	Ø4,9	2230	1690	1.8	250
2815020	0.92		4.8	20	13,0-15,0	16	Ø4,9	2230	1690	1.8	250



ALUMINIO 3,5% MG
ALUMINIUM 3,5% MG

ACERO CINCADO
ZINC PLATED STEEL

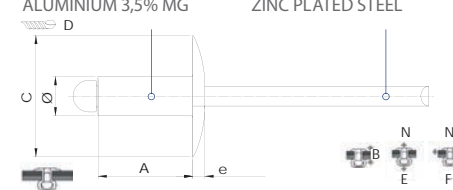

Application: flat or preformed metal sheets or plates, thickness ≥ 1 mm | Do not combine soft elements | Body-shank tightness
 Aplicación: chapas o placas de metal preformadas o planas, espesores ≥ 1 mm | No combinar elementos blandos | Estanqueidad cuerpo-vástago

Dome Head Aluminium/Aluminium
 Flachrundkopf Aluminium/Aluminium
 Cabeza Alomada Alu/Alu

Ref	Kg	Mat	Ø	A	B	C	D	E	F	Thickn. Espesor	Pack
2854808	0.45		4.8	8	2,5-4,0	12.7	Ø6,6-6,9	1700	1300	3	500
2854810	0.5		4.8	10	4,0-6,0	12.7	Ø6,6-6,9	1700	1300	3	500
2854812	0.58		4.8	12	6,0-8,0	12.7	Ø6,6-6,9	1700	1300	3	500
2854814	0.63		4.8	14	8,0-10,0	12.7	Ø6,6-6,9	1700	1300	3	500
2854816	0.65		4.8	16	10,0-12,0	12.7	Ø6,6-6,9	1700	1300	3	500
2854818	0.8		4.8	18	12,0-14,0	12.7	Ø6,6-6,9	1700	1300	3	500
2854820	0.87		4.8	20	13,0-15,0	12.7	Ø6,6-6,9	1700	1300	3	500
2854825	0.49		4.8	25	15,0-20,0	12.7	Ø6,6-6,9	1700	1300	3	250
2854830	0.55		4.8	30	20,0-25,0	12.7	Ø6,6-6,9	1700	1300	3	250
2854835	0.63		4.8	35	25,0-30,0	12.7	Ø6,6-6,9	1700	1300	3	250



ALUMINIO 2,5% MG
ALUMINIUM 2,5% MG

ALUMINIO 7A03
ALUMINIUM 7A03

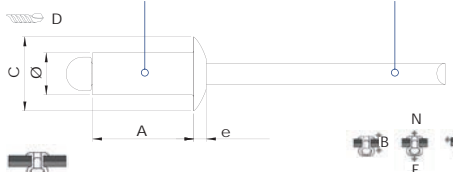

Application: flat or preformed metal sheets or plates, thickness ≥ 1 mm | Do not combine soft elements | Body-shank tightness
 Aplicación: chapas o placas de metal preformadas o planas, espesores ≥ 1 mm | No combinar elementos blandos | Estanqueidad cuerpo-vástago
 UNE-EN ISO 15981

STANDARD RIVET / STANDARD NIETE / REMACHE STANDARD

INDUSTRIAL SUPPLIES / INDUSTRIEBEDARF / SUMINISTROS INDUSTRIALES

Dome Head Steel/Steel
Flachrundkopf Stahl/Stahl
Cabeza Alomada Acero/Acero

NEW

Ref	Kg	Mat	Ø	A	B	C	D	E	F	Thickn. Espesor	Pack
2804012	1.3	STEEL	4.0	12	6,5-8,0	8	Ø4,1	2200	1700	1.3	500

Ref	Kg	Mat	Ø	A	B	C	D	E	F	Thickn. Espesor	Pack
2834806	1.5	STEEL	4.8	6	1,0-2,5	9.5	Ø4,9	3100	2900	1.4	500
2834808	1.6	STEEL	4.8	8	2,5-4,0	9.5	Ø4,9	3100	2900	1.4	500
2834810	1.85	STEEL	4.8	10	4,0-6,0	9.5	Ø4,9	3100	2900	1.4	500
2834812	1.8	STEEL	4.8	12	6,0-8,0	9.5	Ø4,9	3100	2900	1.4	500
2834814	1.95	STEEL	4.8	14	8,0-10,0	9.5	Ø4,9	3100	2900	1.4	500
2834816	2.05	STEEL	4.8	16	9,0-11,0	9.5	Ø4,9	3100	2900	1.4	500
2834818	2.25	STEEL	4.8	18	11,0-13,0	9.5	Ø4,9	3100	2900	1.4	500
2834820	2.4	STEEL	4.8	20	13,0-15,0	9.5	Ø4,9	3100	2900	1.4	500
2834822	2.5	STEEL	4.8	22	15,0-17,0	9.5	Ø4,9	3100	2900	1.4	250
2834825	1.3	STEEL	4.8	25	17,0-20,0	9.5	Ø4,9	3100	2900	1.4	250
2834830	1.4	STEEL	4.8	30	20,0-25,0	9.5	Ø4,9	3100	2900	1.4	250

Ref	Kg	Mat	Ø	A	B	C	D	E	F	Thickn. Espesor	Pack
2836012	1.7	STEEL	6.0	12	4,0-6,0	12	Ø6,1	4800	4300	1.9	250
2836015	1.7	STEEL	6.0	15	6,0-10,0	12	Ø6,1	4800	4300	1.9	250
2836018	1.85	STEEL	6.0	18	9,5-12,5	12	Ø6,1	4800	4300	1.9	250

Ref	Kg	Mat	Ø	A	B	C	D	E	F	Thickn. Espesor	Pack
2836412	1.95	STEEL	6.4	12	4,0-6,0	13	Ø6,5	5700	4900	2.2	250
2836415	1.95	STEEL	6.4	15	6,0-9,0	13	Ø6,5	5700	4900	2.2	250
2836418	2.35	STEEL	6.4	18	9,0-11,0	13	Ø6,5	5700	4900	2.2	250

Application: flat or preformed metal sheets or plates, thickness ≥ 1 mm | Do not combine soft elements | Body-shank tightness
Aplicación: chapas o placas de metal preformadas o planas, espesores ≥ 1 mm | No combinar elementos blandos | Estanqueidad cuerpo-vástago
UNE-EN ISO 14589/15979

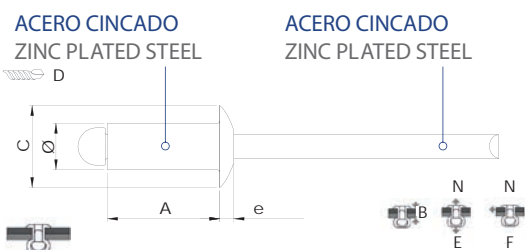

Flat Head Steel/Steel
Flachkopf Stahl/Stahl
Cabeza Ancha Acero/Acero

Ref	Kg	Mat	Ø	A	B	C	D	E	F	Thickn. Espesor	Pack
2831516	1.05	STEEL	4.8	16	9,0-11,0	14	Ø4,9	3100	2900	1.6	250

Application: flat or preformed metal sheets or plates, thickness ≥ 1 mm | Do not combine soft elements | Body-shank tightness
Aplicación: chapas o placas de metal preformadas o planas, espesores ≥ 1 mm | No combinar elementos blandos | Estanqueidad cuerpo-vástago

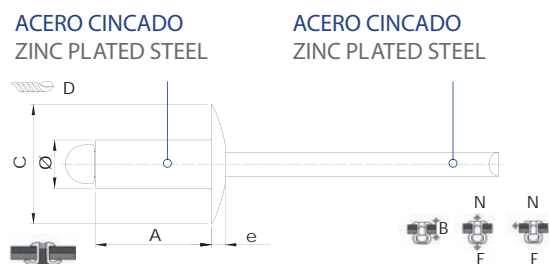

Dome Head Stainless Steel/Stainless Steel Flachrundkopf Edelstahl/Edelstahl Cabeza Alomada Inox/Inox

Ref	Kg	Mat	Ø	A	B	C	D	E	F	Thickn. Espesor	Pack
2801512	1.8	INOX	4.8	12	6,0-8,0	9.5	Ø4,9	5000	4000	1.4	500
2801516	2.05	INOX	4.8	16	9,0-11,0	9.5	Ø4,9	5000	4000	1.4	500
2801520	5.04	INOX	4.8	20	13,0-15,0	9.5	Ø4,9	5000	4000	1.4	500

Ref	Kg	Mat	Ø	A	B	C	D	E	F	Thickn. Espesor	Pack
2801620	2.05	INOX	6.0	20	12,0-14,0	12	Ø6,1	8830	6500	2	250

UNE-EN ISO 14589/15983

Ref	Kg	Mat	Ø	A	B	C	D	E	F	Thickn. Espesor	Pack
2801712	2.05	INOX	6.4	12	4,5-6,0	13	Ø6,5	9300	7500	2.2	250

Application: flat or preformed metal sheets or plates, thickness ≥ 1 mm | Do not combine soft elements | Body-shank tightness
Aplicación: chapas o placas de metal preformadas o planas, espesores ≥ 1 mm | No combinar elementos blandos | Estanqueidad cuerpo-vástago
UNE-EN ISO 14589/15983



ACERO INOXIDABLE A2
STAINLESS STEEL A2

ACERO INOXIDABLE A2
STAINLESS STEEL A2

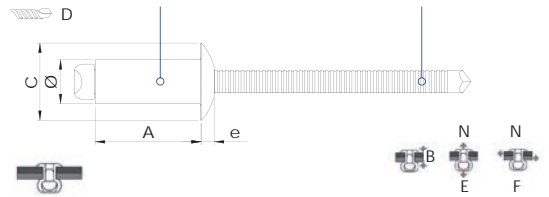

Countersunk Head Stainless Steel/Stainless Steel Senkkopf Edelstahl/Edelstahl Cabeza Avellanada Inox/Inox

NEW

Ref	Kg	Mat	Ø	A	B	C	D	E	F	Pack
2800516	2.25	INOX	4.8	16	9,0-11,0	9	Ø4,9	5000	4000	500

Application: flat or preformed metal sheets or plates, thickness ≥ 1 mm | Do not combine soft elements | Body-shank tightness
Aplicación: chapas o placas de metal preformadas o planas, espesores ≥ 1 mm | No combinar elementos blandos | Estanqueidad cuerpo-vástago
UNE-EN ISO 14589/15984



ACERO INOXIDABLE A2
STAINLESS STEEL A2

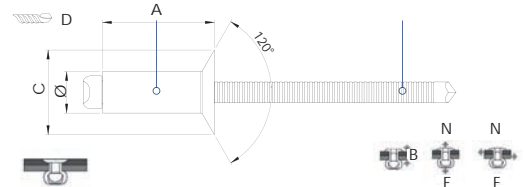

ACERO INOXIDABLE A2
STAINLESS STEEL A2



MULTIGRIP RIVET / MULTIGRIP NIETE / REMACHE MULTIGRIP

INDUSTRIAL SUPPLIES / INDUSTRIEBEDARF / SUMINISTROS INDUSTRIALES

Dome Head Aluminium/Steel
Flachrundkopf Aluminium/Stahl
Cabeza Alomada Aluminio/Acero

Ref	Kg	Mat	Ø	A	B	C	D	E	F	Thickn. Espesor	Pack
2874812	1.25		4.8	12	2,0-8,0	9.5	Ø4,9-5,0	1700	1200	1.5	500
2874816	1.44		4.8	16	6,0-12,0	9.5	Ø4,9-5,0	1700	1200	1.5	500
2874825	0.9		4.8	25	14,0-20,0	9.5	Ø4,9-5,0	1700	1200	1.5	250

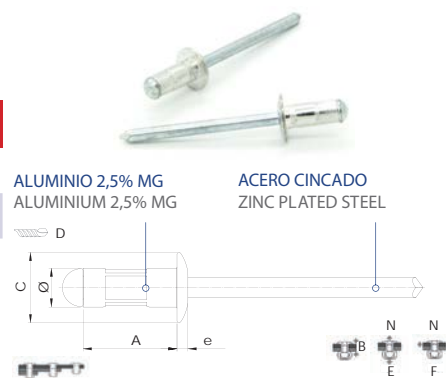

Application: Thicknesses ≥ 1 mm and metal/plastic | Do not combine soft elements | No Body-shank tightness
Aplicación: espesores ≥ 1 mm | Metal con metal/plástico (No combinar elementos blandos); Láminas; Agujero liso | No estanqueidad cuerpo-vástago



ALUMINIO 2,5% MG
ALUMINIUM 2,5% MG

ACERO CINCADO
ZINC PLATED STEEL

Dome Head Black Painted
Flachrundk Lackiert Schwarz
Cabeza Alomada Lacado

Ref	Kg	Mat	Col	Ø	A	B	C	D	E	F	Thickn. Espesor	Pack
2872512	2.48			4.8	12	2,0-8,0	9.5	Ø4,9-5,0	1700	1200	1.5	500

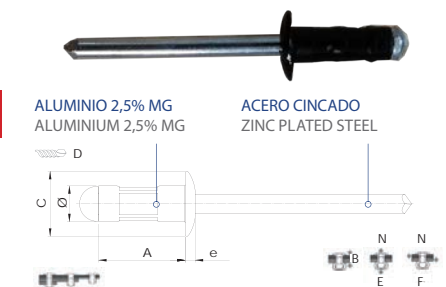

ALUMINIO 2,5% MG
ALUMINIUM 2,5% MG

ACERO CINCADO
ZINC PLATED STEEL

Flat Head Aluminium/Steel
Flachkopf Aluminium/Stahl
Cabeza Ancha Aluminio/Acero

Ref	Kg	Mat	Ø	A	B	C	D	E	F	Thickn. Espesor	Pack
2871516	0.93		4.8	16	6,0-12,0	14	Ø4,9-5,0	1700	1200	1.6	250

Application: Thicknesses ≥ 1 mm and metal/plastic | Do not combine soft elements | No Body-shank tightness
Aplicación: espesores ≥ 1 mm | Metal con metal/plástico (No combinar elementos blandos); Láminas; Agujero liso | No estanqueidad cuerpo-vástago





ALUMINIO 2,5% MG
ALUMINIUM 2,5% MG

ACERO CINCADO
ZINC PLATED STEEL

X-Large Head Aluminium/Steel
X-Large Kopf Aluminium/Stahl
Cabeza Extra Grande Aluminio/Acero

NEW

Ref	Kg	Mat	Ø	A	B	C	D	E	F	Thickn. Espesor	Pack
2875510	0.74		4.8	10	1,0-6,0	16	Ø4,9-5,0	1700	1200	1.8	250
2875516	0.84		4.8	16	6,0-12,5	16	Ø4,9-5,0	1700	1200	1.8	250
2875525	1.03		4.8	25	12,5-20,0	16	Ø4,9-5,0	1700	1200	1.8	250



Application: Thicknesses ≥ 1 mm and metal/plastic | Do not combine soft elements | No Body-shank tightness
Aplicación: espesores ≥ 1 mm | Metal con metal/plástico (No combinar elementos blandos); Láminas; Agujero liso | No estanqueidad cuerpo-vástago



ALUMINIO 2,5% MG
ALUMINIUM 2,5% MG

ACERO CINCADO
ZINC PLATED STEEL

Dome Head Stainless Steel/Stainless Steel
Flachrundkopf Edelstahl/Edelstahl
Cabeza Alomada Inox/Inox

Ref	Kg	Mat	Ø	A	B	C	D	E	F	Thickn. Espesor	Pack
2873512	2.48		4.8	12	2,5-6,5	9.5	Ø4,9-5,0	4500	4100	1.6	500
2873515	2.21		4.8	15	5,5-9,5	9.5	Ø4,9-5,0	4500	4100	1.6	500
2873517	2.33		4.8	17.5	7,0-11,0	9.5	Ø4,9-5,0	4500	4100	1.6	500

Application: Thicknesses ≥ 1 mm and metal/plastic | Do not combine soft elements | No Body-shank tightness
Aplicación: espesores ≥ 1 mm | Metal con metal/plástico (No combinar elementos blandos); Láminas; Agujero liso | No estanqueidad cuerpo-vástago



ACERO INOXIDABLE A2
STAINLESS STEEL A2

ACERO INOXIDABLE A2
STAINLESS STEEL A2

Dome Head Aluminium/Steel
Flachrundkopf Aluminium/Stahl
Cabeza Alomada Aluminio/Acero

Ref	Kg	Mat	Ø	A	B	C	D	E	F	Thickn. Espesor	Pack
2824810	1.25	STEEL	4.8	10	0,5-4,0	9.5	Ø5,2-5,3	1600	1690	1.4	500
2824812	1.35	STEEL	4.8	12	2,0-6,0	9.5	Ø5,2-5,3	1600	1690	1.4	500
2824814	1.5	STEEL	4.8	14	4,0-8,0	9.5	Ø5,2-5,3	1600	1690	1.4	500
2824816	1.65	STEEL	4.8	16	6,0-10,0	9.5	Ø5,2-5,3	1600	1690	1.4	500
2824818	1.68	STEEL	4.8	18	8,0-12,0	9.5	Ø5,2-5,3	1600	1690	1.4	500
2824820	1.73	STEEL	4.8	20	10,0-14,0	9.5	Ø5,2-5,3	1600	1690	1.4	500
2824822	0.83	STEEL	4.8	22	12,0-16,0	9.5	Ø5,2-5,3	1600	1690	1.4	250
2824825	0.9	STEEL	4.8	25	16,0-19,0	9.5	Ø5,2-5,3	1600	1690	1.4	250
2824830	1	STEEL	4.8	30	19,0-24,0	9.5	Ø5,2-5,3	1600	1690	1.4	250
2824835	1	STEEL	4.8	35	24,0-29,0	9.5	Ø5,2-5,3	1600	1690	1.4	250
2824840	1.13	STEEL	4.8	40	29,0-34,0	9.5	Ø5,2-5,3	1600	1690	1.4	250
2824845	1.25	STEEL	4.8	45	34,0-39,0	9.5	Ø5,2-5,3	1600	1690	1.4	250
2824850	1.1	STEEL	4.8	50	38,0-42,0	9.5	Ø5,2-5,3	1600	1690	1.4	200
2824855	0.6	STEEL	4.8	55	42,0-47,0	9.5	Ø5,2-5,3	1600	1690	1.4	100
2824860	0.61	STEEL	4.8	60	47,0-52,0	9.5	Ø5,2-5,3	1600	1690	1.4	100
2824865	0.65	STEEL	4.8	65	52,0-57,0	9.5	Ø5,2-5,3	1600	1690	1.4	100

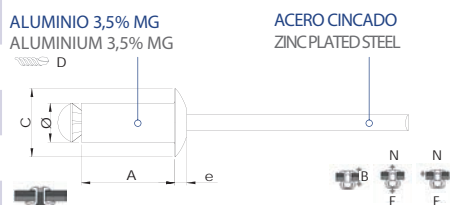

Ref	Kg	Mat	Ø	A	B	C	D	E	F	Thickn. Espesor	Pack
2826435	0.86	STEEL	6.4	35	21,0-26,0	13	Ø6,5-6,6	3200	3300	2.2	100

Application: for soft and / or fragile materials (wood, rubber, plastic, thicknesses ≥ 1 mm and uneven surfaces) | No Body-shank sealing
Aplicación: para materiales blandos y/o frágiles (madera, goma, plástico, espesores ≥ 1 mm y superficies irregulares) | No Estanqueidad cuerpo-vástago
ISO 14588/14589/15977

Dome Head Aluminium/Steel White Painted
Flachrundkopf Aluminium/Stahl Lackiert Weiss
Cabeza Alomada Aluminio/Acero Lacado Blanco

NEW

Ref	Kg	Mat	Col	Ø	A	B	C	D	E	F	Thickn. Espesor	Pack
2825512	1.31	STEEL	○	4.8	12	2,0-6,0	9.5	Ø5,2-5,3	1600	1690	1.4	500
2825516	1.45	STEEL	○	4.8	16	6,0-10,0	9.5	Ø5,2-5,3	1600	1690	1.4	500
2825520	0.73	STEEL	○	4.8	20	10,0-14,0	9.5	Ø5,2-5,3	1600	1690	1.4	250

ISO 15977

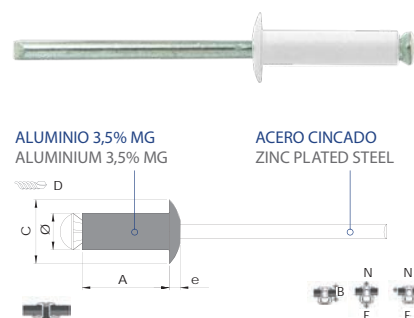

Dome Head Aluminium/Steel Black Painted
Flachrundkopf Aluminium/Stahl Lackiert Schwarz
Cabeza Alomada Aluminio/Acero Lacado Negro

NEW

Ref	Kg	Mat	Col	Ø	A	B	C	D	E	F	Thickn. Espesor	Pack
2824520	1.59	STEEL	●	4.8	20	10,0-14,0	14	Ø5,2-5,3	1600	1690	1.8	500



INDUSTRIAL SUPPLIES / INDUSTRIEBEDARF / SUMINISTROS INDUSTRIALES



FLOWER RIVET / FLOR NIETE / REMACHE FLOR

INDUSTRIAL SUPPLIES / INDUSTRIEBEDARF / SUMINISTROS INDUSTRIALES

Flat Head Aluminium/Steel
Flachkopf Aluminium/Stahl
Cabeza Ancha Aluminio/Acero

Ref	Kg	Mat	Ø	A	B	C	D	E	F	Thickn. Espesor	Pack
2821516	0.95		4.8	16	6,0-10,0	14	Ø5,2-5,3	1600	1690	1.8	250
2821520	0.9		4.8	20	10,0-14,0	14	Ø5,2-5,3	1600	1690	1.8	250
2821524	1.43		4.8	24	16,0-19,0	14	Ø5,2-5,3	1600	1690	1.8	250
2821535	0.68		4.8	35	24,0-29,0	14	Ø5,2-5,3	1600	1690	1.8	150

Application: for soft and / or fragile materials (wood, rubber, plastic, thicknesses ≥ 1 mm and uneven surfaces) | No Body-shank sealing
Aplicación: para materiales blandos y/o frágiles (madera, goma, plástico, espesores ≥ 1 mm y superficies irregulares) | No Estanqueidad cuerpo-vástago



ALUMINIO 3,5% MG
ALUMINIUM 3,5% MG

ACERO CINCADO
ZINC PLATED STEEL

Flat Head Aluminium/Steel Painted
Flachkopf Aluminium/Stahl Lackiert
Cabeza Ancha Aluminio/Acero Lacado Blanco

NEW

Ref	Kg	Mat	Col	Ø	A	B	C	D	E	F	Thickn. Espesor	Pack
2822518	0.9			4.8	18	8,0-12,0	14	Ø5,2-5,3	1600	1690	1.8	250



ALUMINIO 3,5% MG
ALUMINIUM 3,5% MG

ACERO CINCADO
ZINC PLATED STEEL

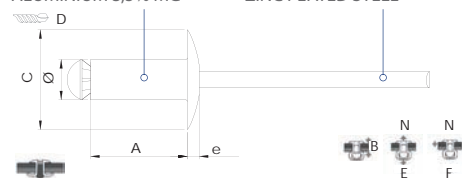

Flat Head Aluminium/Steel Painted
Flachkopf Aluminium/Stahl Lackiert
Cabeza Ancha Aluminio/Acero Lacado Negro

NEW

Ref	Kg	Mat	Ø	A	B	C	D	E	F	Thickn. Espesor	Pack
2823520	0.95		4.8	20	10,0-14,0	14	Ø5,2-5,3	1600	1690	1.8	250



ALUMINIO 3,5% MG
ALUMINIUM 3,5% MG

ACERO CINCADO
ZINC PLATED STEEL

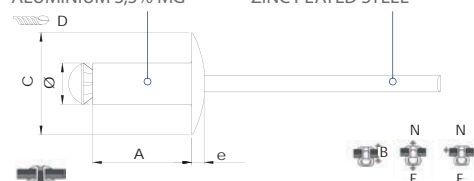

Dome Head Aluminium/Stainless Steel
Flachrundkopf Aluminium/Edelstahl
Cabeza Alomada Aluminio/Inox

Ref	Kg	Mat	Ø	A	B	C	D	E	F	Thickn. Espesor	Pack
2820512	1.35		4.8	12	2,0-6,0	9.5	Ø5,2-5,3	1600	1690	1.4	500

Application: for soft and / or fragile materials (wood, rubber, plastic, thicknesses ≥ 1 mm and uneven surfaces) | No Body-shank sealing
Aplicación: para materiales blandos y/o frágiles (madera, goma, plástico, espesores ≥ 1 mm y superficies irregulares) | No Estanqueidad cuerpo-vástago



ALUMINIO 3,5% MG
ALUMINIUM 3,5% MG

ACERO INOXIDABLE A2
STAINLESS STEEL A2

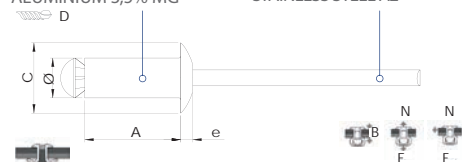

Dome Head Aluminium/Aluminium Flachrundkopf Aluminium/Stahl Cabeza Alomada Aluminio/Acero

Ref	Kg	Mat	Ø	A	B	C	D	E	F	Thickn. Espesor	Pack
2884811	1.15		4.8	11	5,0-6,5	9.5	Ø4,9	3100	2200	2	500
2884812	1.25		4.8	12.5	6,5-8,0	9.5	Ø4,9	3100	2200	2	500
2884818	1.25		4.8	18	11,0-13,0	9.5	Ø4,9	3100	2200	2	500
2884825	0.9		4.8	25	15,0-19,0	9.5	Ø4,9	3100	2200	2	250

Ref	Kg	Mat	Ø	A	B	C	D	E	F	Thickn. Espesor	Pack
2886416	1.55		6.4	16	7,0-10,0	12.7	Ø6,5	4900	3600	2.5	250

Application: Metal parts thickness ≥ 1 mm | Not recommended for wood, plastic or soft materials | Body-shank tightness
 Aplicación: Partes metálicas de espesores desde al menos ≥ 1 mm | No recomendable: madera, plástico o materiales blandos |
 Estandeidad cuerpo-vástag
 ISO 15973



ALUMINIO 5% MG
ALUMINIUM 5% MG

ACERO PAVONADO
BLUED STEEL

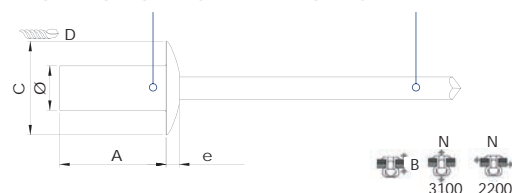

Dome Head Stainless Steel A-2/Stainless Steel Flachrundkopf Edelstahl A-2/Edelstahl Cabeza Alomada Inox A-2/Inox

NEW

Ref	Kg	Mat	Ø	A	B	C	D	E	F	Thickn. Espesor	Pack
2883512	1.95		4.8	12	5,0-6,5	9.5	Ø4,9	4400	4000	2	500
2883516	2.25		4.8	16	7,0-9,0	9.5	Ø4,9	4400	4000	2	500
2881520	1.95		4.8	20	10,5-13,0	9.5	Ø4,9	4400	4000	2	500

Application: Metal parts thickness ≥ 1 mm | Not recommended for wood, plastic or soft materials | Body-shank tightness
 Aplicación: Partes metálicas de espesores desde al menos ≥ 1 mm | No recomendable: madera, plástico o materiales blandos |
 Estandeidad cuerpo-vástag
 ISO 14589/16585



ACERO INOXIDABLE A2
STAINLESS STEEL A2

ACERO INOXIDABLE 2Cr13
STAINLESS STEEL 2Cr13

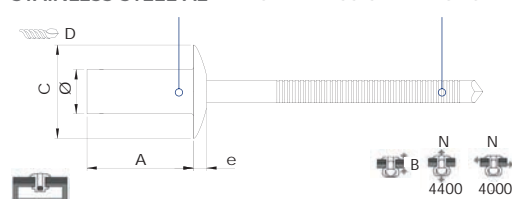

Multigrip Steel/Steel
Multigrip Stahl/Stahl
Cabeza Alomada Acero/Acero

Ref	Kg	Mat	Ø	A	B	C	D	E	F	Thickn. Espesor	Pack
2846023	1.95		6.0	19-23,2	9,0-12,0	12	Ø6,1	5400	8500	1.8	250

Application: Thicknesses ≥ 1 mm and metal / metal or metal / plastic High shear and tensile strength | Body-shank tightness
Aplicación: espesores ≥ 1 mm | Todo tipo de metal con metal/metal con plástico | Estanqueidad cuerpo-vástago

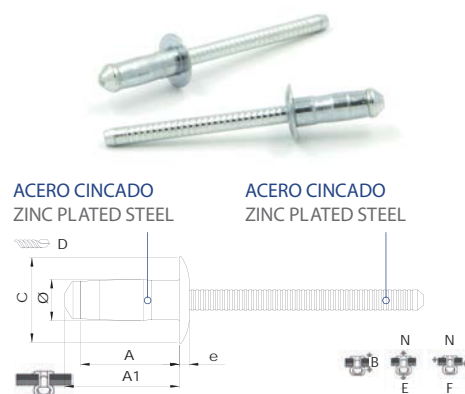

ACERO CINCADO
ZINC PLATED STEEL

ACERO CINCADO
ZINC PLATED STEEL

Multigrip Stainless Steel/Stainless Steel
Multigrip Edelstahl/Edelstahl
Multigrip Cabeza Alomada Inox/Inox

Ref	Kg	Mat	Ø	A	B	C	D	E	F	Thickn. Espesor	Pack
2842515	2.2		4.8	11,5-15,5	3,5-6,0	9.5	Ø4,9	5000	3900	1.5	500

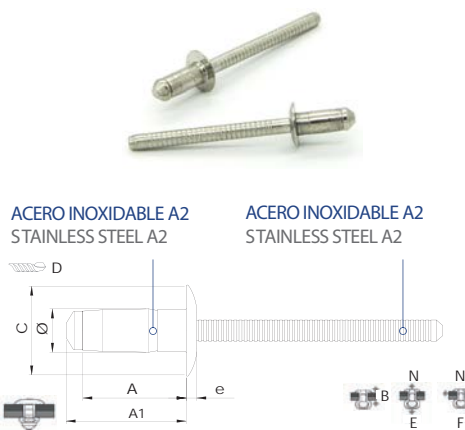

ACERO INOXIDABLE A2
STAINLESS STEEL A2

ACERO INOXIDABLE A2
STAINLESS STEEL A2

Cup Lock Dome Head Alu/Alu
Cup Lock Flachrundkopf Alu/Alu
Cup Lock Cabeza Alomada Alu/Alu

Ref	Kg	Mat	Ø	A	B	C	D	E	F	Thickn. Espesor	Pack
2864814	0.7		4.8	14	1,6-11,0	9.5	Ø4,9-5,1	2000	2400	2.2	500

Ref	Kg	Mat	Ø	A	B	C	D	E	F	Thickn. Espesor	Pack
2866414	0.4		6.4	14	2,0-9,5	12.7	Ø6,6-6,9	3600	5600	3	250
2866420	0.2		6.4	20	2,0-15,9	12.7	Ø6,6-6,9	3600	5600	3	200

Application: Thicknesses ≥ 1 mm and metal / metal or metal / plastic High shear and tensile strength | Body-shank tightness
Aplicación: Espesores ≥ 1 mm y metal/metal o metal/plástico | Alta resistencia al cizallamiento y a la tracción | Estanqueidad cuerpo-vástago



ALUMINIO 5% MG
ALUMINIUM 5% MG

ALUMINIO 7A03
ALUMINIUM 7A03

Dome Head Steel/Steel
Flachrundkopf Stahl/Stahl
Cup Lock Cabeza Alomada Acero/Acero

Ref	Kg	Mat	Ø	A	B	C	D	E	F	Thickn. Espesor	Pack
2844814	1.95		4.8	14	1,6-11,0	9.5	Ø4,9-5,1	4400	5700	2.2	500

Ref	Kg	Mat	Ø	A	B	C	D	E	F	Thickn. Espesor	Pack
2846414	0.86		6.4	14	2,0-9,5	12.7	Ø6,6-6,9	8200	10600	3	250
2846314	1.78		6.4	14	2,0-9,5	12.7	Ø6,6-6,9	8200	10600	3	200
2846420	1.76		6.4	20	2,0-15,9	12.7	Ø6,6-6,9	8200	10600	3	200

Application: Thicknesses ≥ 1 mm and metal / metal or metal / plastic High shear and tensile strength | Body-shank tightness
Aplicación: Espesores ≥ 1 mm y metal/metal o metal/plástico | Alta resistencia al cizallamiento y a la tracción | Estanqueidad cuerpo-vástago



ACERO CINCADO
ZINC PLATED STEEL

ACERO CINCADO
ZINC PLATED STEEL

Cup Lock Countersunk Head Steel/Steel
Cup Lock Senkkopf Stahl/Stahl
Cup Lock Cabeza Avellanada Acero/Acero

Ref	Kg	Mat	Ø	A	B	C	D	E	F	Thickn. Espesor	Pack
2841617	1.03	STEEL	6.4	17	4,1-12,1	10.6	Ø6,6-6,9	8200	10600	2	250
2841623	1.88	STEEL	6.4	23	10,5-18,4	10.6	Ø6,6-6,9	8200	10600	2	200

Application: Thicknesses \geq 1 mm and metal / metal or metal / plastic High shear and tensile strength | Body-shank tightness
Aplicación: Espesores \geq 1 mm y metal/metal o metal/plástico | Alta resistencia al cizallamiento y a la tracción | Estanqueidad cuerpo-vástago



ACERO CINCADO
ZINC PLATED STEEL

ACERO CINCADO
ZINC PLATED STEEL

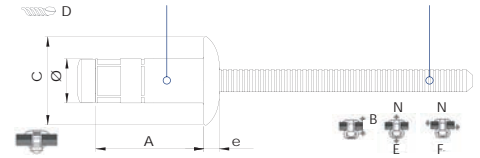

Dome Head Stainless Steel/Stainless Steel
Niete Flachrundkopf Edelstahl/Edelstahl
Cabeza Alomada Inox/Inox

NEW

Ref	Kg	Mat	Ø	A	B	C	D	E	F	Thickn. Espesor	Pack
2843614	2.2	INOX	6.4	14.5	2,0-9,5	12.7	Ø6,6-6,9	8200	10600	3	250
2843620	2.08	INOX	6.4	20.5	2,0-15,9	12.7	Ø6,6-6,9	8200	10600	3	200

Application: Thicknesses \geq 1 mm and metal / metal or metal / plastic High shear and tensile strength | Body-shank tightness
Aplicación: Espesores \geq 1 mm y metal/metal o metal/plástico | Alta resistencia al cizallamiento y a la tracción | Estanqueidad cuerpo-vástago



ACERO INOXIDABLE A2
STAINLESS STEEL A2

ACERO INOXIDABLE A2
STAINLESS STEEL A2

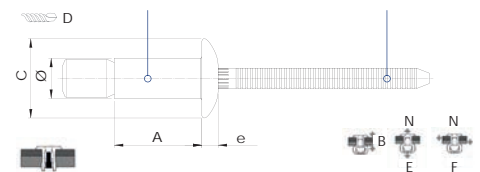

Cup Lock Countersunk Head Stainless Steel/Stainless Steel
Cup Lock Senkkopf Edelstahl/Edelstahl
Cup Lock Cabeza Avellanada Inox/Inox

NEW

Ref	Kg	Mat	Ø	A	B	C	D	E	F	Thickn. Espesor	Pack
2843623	1.86	INOX	6.4	23.5	10,5-18,4	10.6	Ø6,6-6,9	8200	10600	2	200

Application: Thicknesses \geq 1 mm and metal / metal or metal / plastic High shear and tensile strength | Body-shank tightness
Aplicación: Espesores \geq 1 mm y metal/metal o metal/plástico | Alta resistencia al cizallamiento y a la tracción | Estanqueidad cuerpo-vástago



ACERO INOXIDABLE A2
STAINLESS STEEL A2

ACERO INOXIDABLE A2
STAINLESS STEEL A2

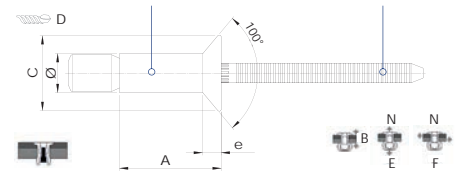

H-Lock Steel/Steel
H-Lock Stahl/Stahl
H.Lock Cabeza Alomada Acero/Acero

NEW

Ref	Kg	Mat	Ø	A	B	C	D	E	F	Thickn. Espesor	Pack
2841614	2.35	STEEL	6.4	14.5	6,8-8,8	12.8	Ø6,5-6,7	6500	9000	2.9	250
2841610	1.95	STEEL	6.4	12.5	2,4-4,8	12.8	Ø6,5-6,7	6500	9000	2.9	250
2841612	2	STEEL	6.4	12.5	4,8-6,8	12.8	Ø6,5-6,7	6500	9000	2.9	250
2841616	2.35	STEEL	6.4	16.5	8,8-10,8	12.8	Ø6,5-6,7	6500	9000	2.9	200
2841618	2.5	STEEL	6.4	18.5	10,8-12,8	12.8	Ø6,5-6,7	6500	9000	2.9	200
2841620	2.1	STEEL	6.4	20.5	12,8-14,8	12.8	Ø6,5-6,7	6500	9000	2.9	200



ACERO CINCADO
ZINC PLATED STEEL

ACERO CINCADO
ZINC PLATED STEEL

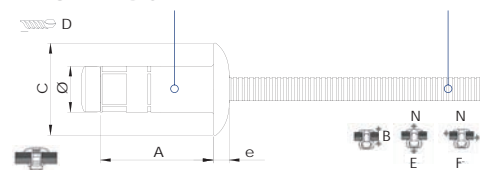

Ref	Kg	Mat	Ø	A	B	C	D	E	F	Thickn. Espesor	Pack
2841816	2.13	STEEL	7.8	16	7,0-10,0	16	Ø8,0-8,3	9300	10600	3.6	150

Application: Thicknesses \geq 1 mm and metal / metal or metal / plastic High shear and tensile strength | Body-shank tightness
Aplicación: Espesores \geq 1 mm y metal/metal o metal/plástico | Alta resistencia al cizallamiento y a la tracción | Estanqueidad cuerpo-vástago

ADAPLY



The ADAPLY rivet is a riveted joint system. It fixes the board to the chassis, and also offers great resistance to traction and shear.

El remache ADAPLY es un sistema de unión remachada. Fija el tablero con el chasis, y además, ofrece una gran resistencia a la tracción y cizallamiento.



ADVANTAGES/FEATURES

- ✓ Durable and indivisible fixation.
- ✓ Improves other conventional joining systems.
- ✓ Quick installation in chain work systems.
- ✓ Car countersunk head on truck floor without pre-countersunk hole.
- ✓ Great resistance to traction and shear.
- ✓ Wide riveting range.

VENTAJAS/CARACTERÍSTICAS

- ✓ Fijación duradera e indivisible.
- ✓ Mejora otros sistema de unión convencionales.
- ✓ Rápida instalación en sistemas de trabajo en cadena.
- ✓ Auto avellanado de la cabeza en el suelo del camión sin agujero previo avellanado.
- ✓ Gran resistencia a la rotura por tracción y/o cizallamiento.
- ✓ Amplio rango de remachado.

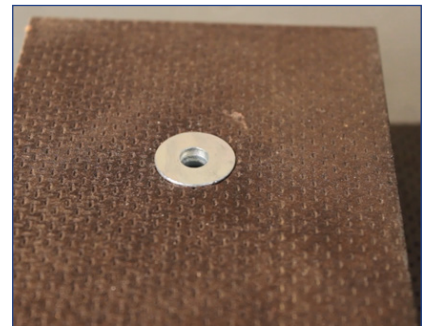
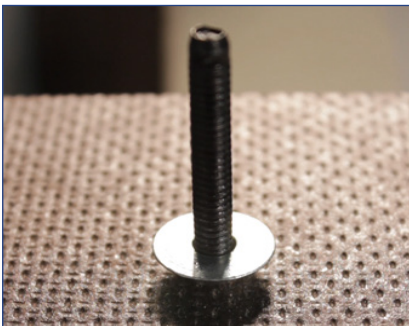

ADAPLY Rivet Standard Head Steel/Steel
ADAPLY Niete Standard Stahl/Stahl
Remache ADAPLY Cabeza Standard Acero/Acero

NEW

Ref	Kg	Mat	Sup/Finish Acabado	Ø	C	D	Thickn. Espesor	Pack
2898054	12.5	STEEL STEEL	Zn	8.0	17	Ø8,3-8,6	5.5	500

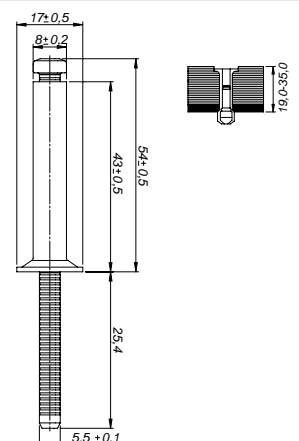

Lock Bolt Supergrip Steel Ø4,8
Sperrbolzen Supergrip Stahl Ø4,8
Perno Supergrip Cabeza Alomada Acero Ø4,8

NEW

Ref	Kg	Mat	Ø	A	B	C	D	Thickn. Espesor	Pack
2892546	17	STEEL	4.8	46	1,6-15,9	9.5	Ø5,1	3	1000

Lock bolt not included (2890248)
No incluye collarin (2890248)

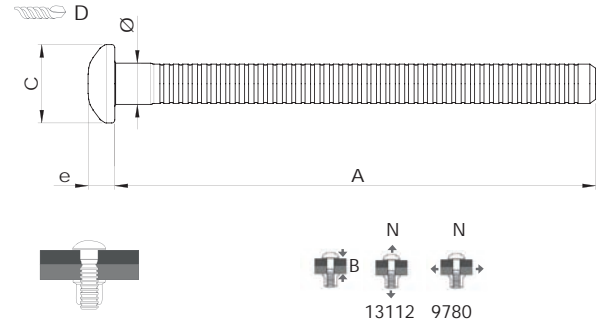

Lock Bolt Supergrip Steel Ø6,4
Sperrbolzen Supergrip Stahl Ø6,4
Perno Supergrip Cabeza Alomada Acero Ø6,4

NEW

Ref	Kg	Mat	Ø	A	B	C	D	Thickn. Espesor	Pack
2891653	12.36	STEEL	6.4	53	1,6-15,9	12.5	Ø6,6	3.6	1000

Lock bolt not included (2890164)
No incluye collarin (2890164)

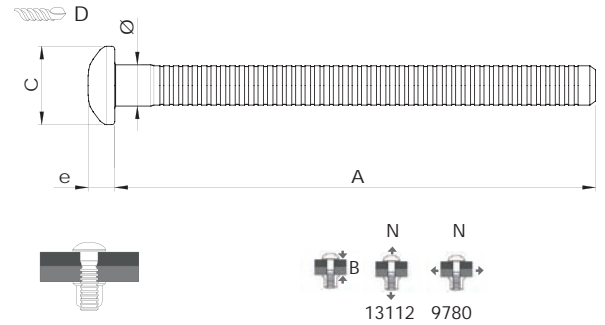

Collar Lock Bolt Supergrip Steel
Pilzgriff Sperrbolzen Supergrip Stahl
Collarin Perno Supergrip Cabeza Alomada Acero

NEW

Ref	Kg	Mat	Ø	A	B	C	Pack
2890164	4	STEEL	6.4	10	9.9	13	1000
2890248	17	STEEL	4.8	8	10	7.3	1000

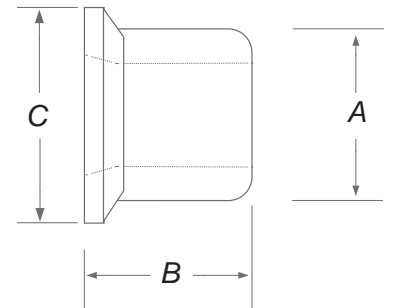

Lock Bolt Bull-Lock Steel Ø4,8 Flat Head
Sperrbolzen Bull-Lock Stahl Ø4,8 Flachkopf
Perno Supergrip Cabeza Plana Acero Ø4,8

NEW

Ref	Kg	Mat	Sup/Finish Acabado	Ø	Pack
2893546	6.8	STEEL	Zn	4.8	1000

Lock bolt not included (2890348)
No incluye collarin (2890348)

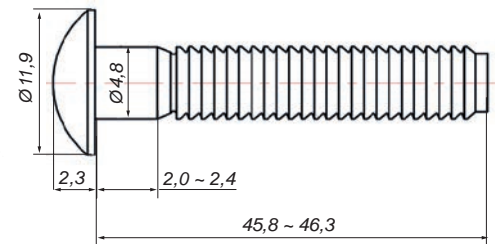

Collar Lock Bolt Supergrip Steel Ø4.8
Pilzgriff Sperrbolzen Supergrip Stahl Ø4.8
Collarin Perno Supergrip Cabeza Ancha Acero Ø4.8

NEW

Ref	Kg	Mat	Sup/Finish Acabado	Col	Ø	Pack
2890348	2.8	STEEL	Zn	Yellow	4.8	1000

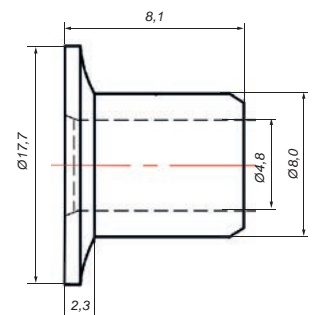

LOCK BOLT-COLLAR BOLT / SPERRBOLZEN-PILZGRIFF / PERNO-COLLARIN

INDUSTRIAL SUPPLIES / INDUSTRIEBEDARF / SUMINISTROS INDUSTRIALES

Lock Bolt Bull-Lock Steel Ø4,8 Dome Head
 Sperrbolzen Bull-Lock Stahl Ø4,8 Flachrundkopf
 Perno Bull-Lock Acero Ø4,8 Cabeza Alomada

NEW

Ref	Kg	Mat	Ø	A	B	C	D	Thickn. Espesor	Pack
2894836	2.8	STEEL	4.8	35.6	1,6-4,8	9.5	Ø5,0	3.2	500
2894839	6	STEEL	4.8	38.9	4,8-8,0	9.5	Ø5,0	3.2	500

Lock bolt not included (2897966)
 No incluye collarin (2897966)

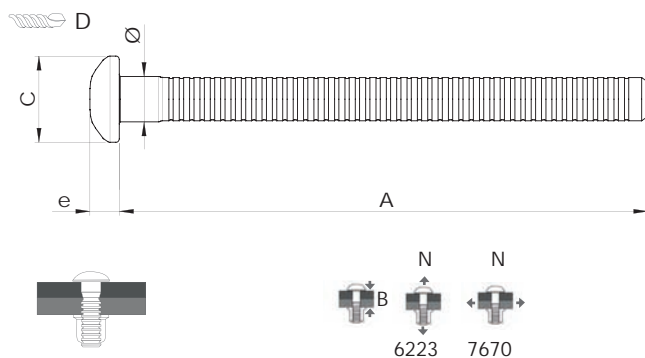

Lock Bolt Bull-Lock Steel Ø6,4 Dome Head
 Sperrbolzen Bull-Lock Stahl Ø6,4 Flachrundkopf
 Perno Bull-Lock Acero Ø6,4 Cabeza Alomada

NEW

Ref	Kg	Mat	Ø	A	B	C	D	Thickn. Espesor	Pack
2896439	10.2	STEEL	6.4	38.6	1,6-4,8	12.6	Ø6,6	3.65	1000
2896442	11	STEEL	6.4	41.8	4,8-8,0	12.6	Ø6,6	3.65	1000

Lock bolt not included (2891081)
 No incluye collarin (2891081)

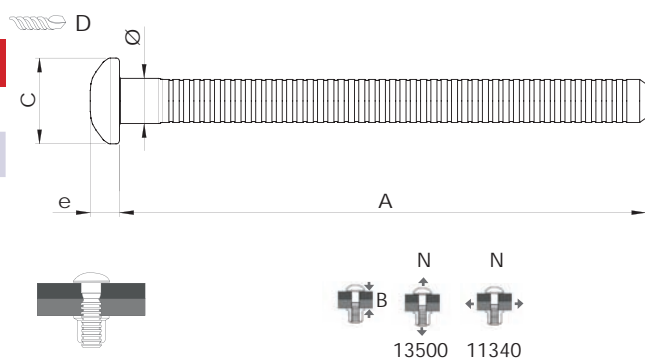

Collar Lock Bolt Bull-Lock Steel
 Pilzgriff Sperrbolzen Bull-Lock Stahl
 Collarin Perno Bull-Lock Ala Normal Acero

NEW

Ref	Kg	Mat	Ø	A	B	C	Pack
2891081	3	STEEL	6.4	10,2-10,4	7,4-8,2	6,75	1000
2897966	2	STEEL	4.8	7,7-7,9	5,5-6,6	5	1000

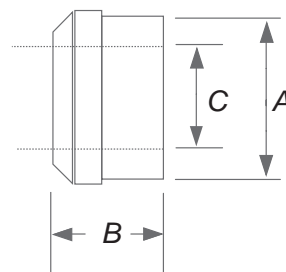

Lock Bolt Bull-Lock Flat Head Aluminium Ø6,4
 Sperrbolzen Bull-Lock Flachkopf Aluminium Ø6,4
 Perno Bull-Lock Aluminium Cabeza Ancha Ø6,4

NEW

Ref	Kg	Mat	Ø	Pack
2896441	6.5	ALUMINIUM	6.4	1000

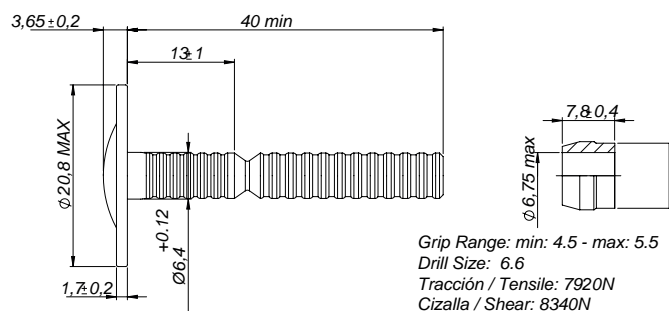

Flat Head Cylindrical Grooved Open End Zylindrisch Gerillt Flachkopf Cabeza Ancha Cilíndrica Ranurada Abierta

NEW

Ref	Kg	Mat	Metric	A	B	C	D	E	F	Thickn. Espesor	Pack
2890012	1.8	STEEL	M5	12	0,5-3,0	9,5-6,9	Ø7,0	10000	6,0	1	500
2890003	1.7	STEEL	M6	14.5	0,5-3,0	12,5-8,9	Ø9,0	15000	10,0	1.5	500
2890011	1.45	STEEL	M8	16	0,5-3,0	15,5-10,9	Ø11,0	27000	24,0	1.5	250
2890030	1.4	STEEL	M10	17	1,0-3,5	18,5-12,9	Ø13,0	37000	48,0	2	200
2890031	1.2	STEEL	M12	23	1,0-4,0	22,5-15,9	Ø16,0	54000	82,0	2	100

Materials where only one side is accessible | It's recommended for applications as tubes, extrusion, metal sheets and plastic
Adecuada para aplicaciones de un único acceso | Recomendable para tubos, extrusión, chapas metálicas y plástico.

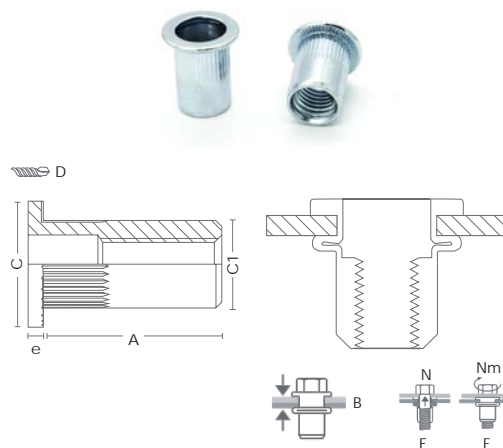

Reduced Head Cylindrical Grooved Open End Zylindrisch gerillt Reduzierter Senkkopf Cabeza Reducida Cilíndrica Ranurada Abierta

Ref	Kg	Mat	Metric	A	B	C	D	E	F	Thickn. Espesor	Pack
2890006	1.15	STEEL	M8	15.5	0,5-3,0	11,5-10,9	Ø11,0	27000	24,0	0.5	250
2890032	1.45	STEEL	M6	14	0,5-3,0	9,5-8,9	Ø9,0	15000	10,0	0.5	500

Materials where only one side is accessible | It's recommended for applications as tubes, extrusion, metal sheets and plastic
Adecuada para aplicaciones de un único acceso | Recomendable para tubos, extrusión, chapas metálicas y plástico.

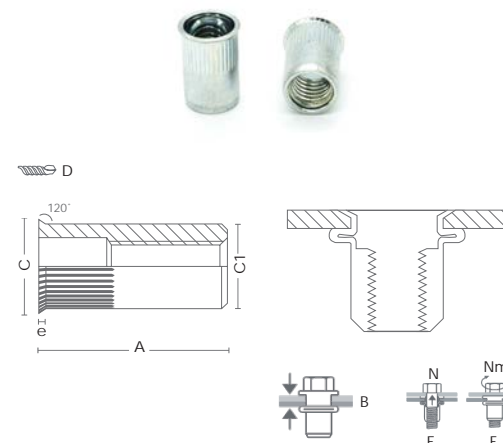

Small Head Semi-Hex Open End Kleiner Seinkopf Semi-Hex Cabeza Reducida Semi-Hexagonal Abierta

NEW

Ref	Kg	Mat	Metric	A	B	C	D	E	F	Thickn. Espesor	Pack
2890021	3.85	STEEL	M6	15.5	0,5-3,0	10,0-8,9	9.1	15000	10,0	0.5	500
2890010	1.4	STEEL	M8	17	0,5-3,0	12,0-10,9	11.1	27000	24,0	0.5	250

Materials where only one side is accessible | It's recommended for applications as tubes, extrusion, metal sheets and plastic
Adecuada para aplicaciones de un único acceso | Recomendable para tubos, extrusión, chapas metálicas y plástico.

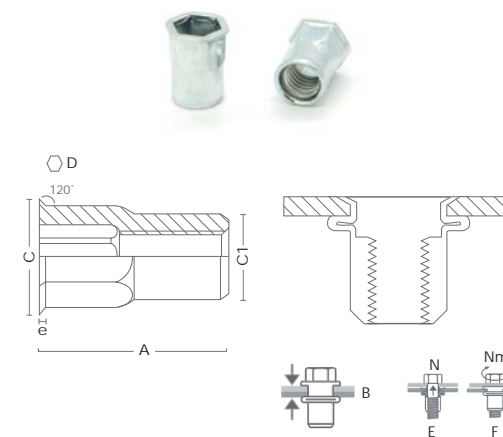

Flat Head Hexagonal Open End Kleiner Flachkopf Sechskant Cabeza Ancha Hexagonal Abierta

NEW

Ref	Kg	Mat	Metric	A	B	C	D	E	F	Thickn. Espesor	Pack
2890018	7.43	STEEL	M8	17.5	0,5-3,0	15,5-10,8	11	27000	24,0	1.5	250
2890023	1.53	STEEL	M10	22	1,0-4,0	16-12,9	13.1	37000	48,0	2	150
2890033	2.1	STEEL	M6	15.5	0,5-3,0	12,0-8,8	9,0	15000	10,0	1.5	500

Materials where only one side is accessible | It's recommended for applications as tubes, extrusion, metal sheets and plastic
Adecuada para aplicaciones de un único acceso | Recomendable para tubos, extrusión, chapas metálicas y plástico.

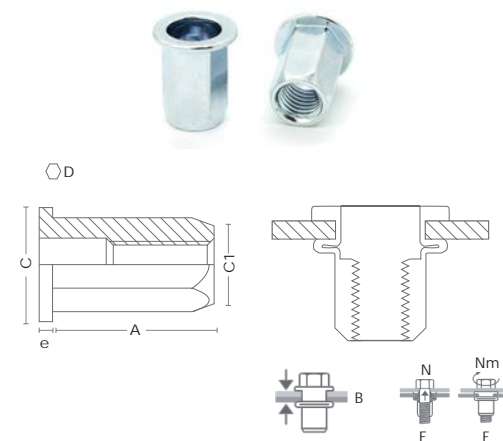



RIVER NUT / NIETMUTTER / TUERCAS REMACHABLES

INDUSTRIAL SUPPLIES / INDUSTRIEBEDARF / SUMINISTROS INDUSTRIALES

Reduced Head Hexagonal Open End
Sechskant Reduzierter Senkkopf
Cabeza Reducida Hexagonal Abierta

Ref	Kg	Mat	Metric	A	B	C	D	E	F	Thickn. Espesor	Pack
2890001	1.9	STEEL	M6	16	0,5-3,0	10,0-8,9	9.1	15000	10,0	0.7	500
2890002	1.4	STEEL	M8	18	0,5-3,0	12-10,9	11.1	27000	24,0	0.7	250
2890022	1.54	STEEL	M8	20.5	4,0-6,0	12-10,9	11.1	27000	24,0	0.7	250

Materials where only one side is accessible | It's recommended for applications as tubes, extrusion, metal sheets and plastic
Adecuada para aplicaciones de un único acceso | Recomendable para tubos, extrusión, chapas metálicas y plástico.

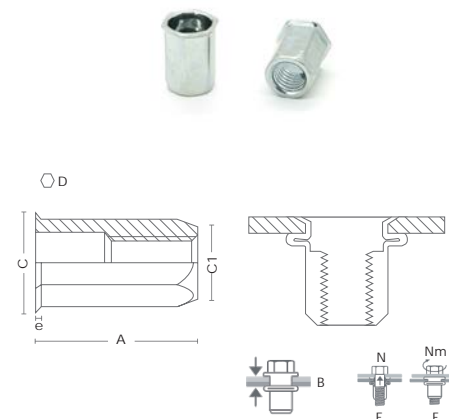

Reduced Head Hexagonal Close End
Sechskant Reduzierter Geschlossen
Cabeza Reducida Hexagonal Cerrada

NEW

Ref	Kg	Mat	Metric	A	B	C	D	E	F	Thickn. Espesor	Pack
2890019	1.86	STEEL	M8	23	0,5-3,0	12-10,9	11.1	27000	24,0	0.7	200

Materials where only one side is accessible | It's recommended for applications as tubes, extrusion, metal sheets and plastic
Adecuada para aplicaciones de un único acceso | Recomendable para tubos, extrusión, chapas metálicas y plástico.

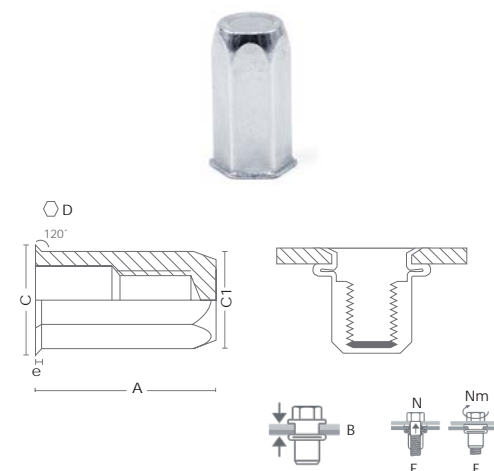

Flat Head Cylindrical Grooved Open End M8, Stainless Steel
Zylindrisch Gerillt Flachkopf M8, Edelstahl
Cabeza Ancha Ranurada Abierta M8

NEW

Ref	Kg	Mat	Metric	A	B	C	D	E	F	Thickn. Espesor	Pack
2890020	5.8	INOX	M8	16	0,5-3,0	15,5-10,9	Ø11,0	27000	24,0	1.5	250

Materials where only one side is accessible | It's recommended for applications as tubes, extrusion, metal sheets and plastic
Adecuada para aplicaciones de un único acceso | Recomendable para tubos, extrusión, chapas metálicas y plástico.

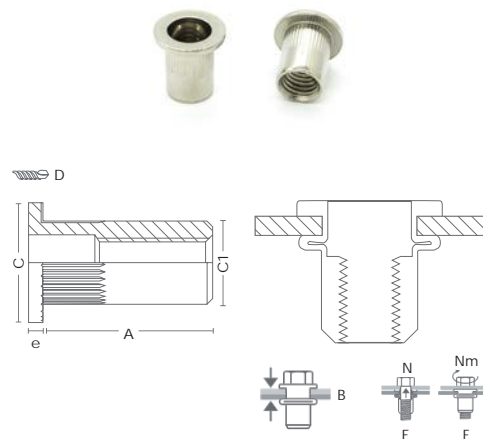

Flat Head Cylindrical Grooved Open End, Aluminium
Zylindrisch Gerillt Flachkopf, Aluminium
Cabeza Ancha Cilíndrica Ranurada Abierta, Aluminio

NEW

Ref	Kg	Mat	Metric	A	B	C	D	E	F	Thickn. Espesor	Pack
2890004	0.32	ALU	M5	12	0,5-3,0	10,0-6,9	Ø7,0	5500	4,0	1	500

Materials where only one side is accessible | It's recommended for applications as tubes, extrusion, metal sheets and plastic
Adecuada para aplicaciones de un único acceso | Recomendable para tubos, extrusión, chapas metálicas y plástico.

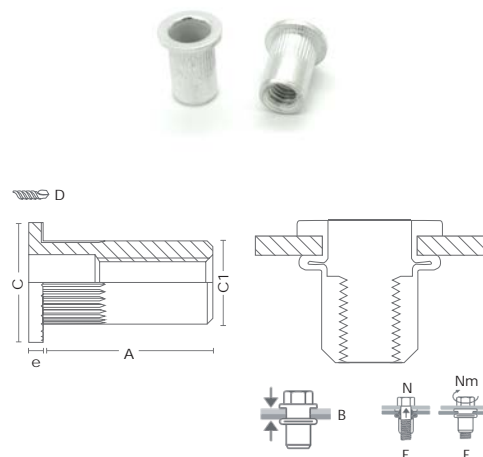

Hinge Plate 50x18x6
 Einlegeschiene f. Scharnier 50x18x6 Verzinkt
 Pletina Bisagra 50x18x6

Ref	Kg	Mat	Sup/Finish Acabado	Lot	Pack
2102049	1.95	STEEL	Zn	1	50

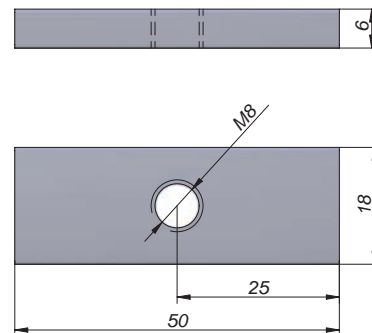
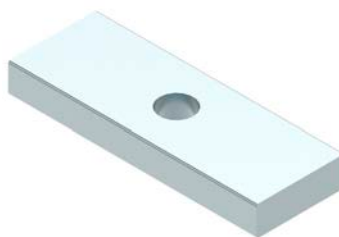

Hinge Plate 137x18x6 Zinc Plated 3 Holes
 Einlegeschiene 3-Loch f. Scharnier 137x18x6 Verzinkt
 Pletina Bisagra 137x18x6 Cincado 3 Agujeros

Ref	Kg	Mat	Sup/Finish Acabado	Lot	Pack
2102052	1.05	STEEL	Zn	1	10

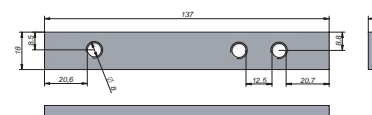
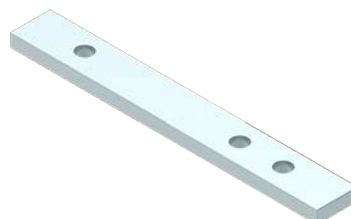

Zinc Plated Sleeve Nut
 Hülsenmutter Verzinkt
 Vaso Roscados Cincado

Ref	Kg	Mat	Sup/Finish Acabado	A	Metric	Lot	Pack
2102021	1.25	STEEL	Zn	23	M8	1	50
2102025	1.5	STEEL	Zn	27	M8	1	50

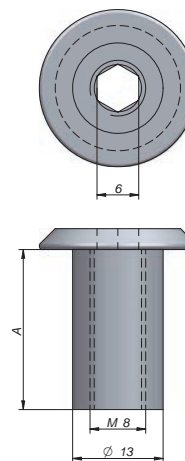

Bolt Allen DIN 912
 Zylinderschraube mit Innensechskant DIN 912
 Tornillo Allen DIN 912

Ref	Kg	Mat	Sup/Finish Acabado	A	Metric	Hard. Dureza	Lot
2101030	0.01	STEEL	Zn	20	M8x20	8.8	50

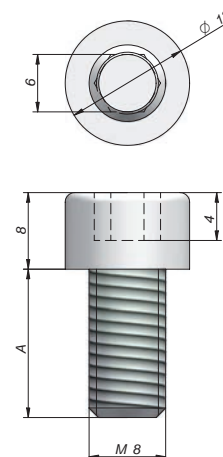



BOLTS / SCHRAUBEN / TORNILLERÍA

INDUSTRIAL SUPPLIES / INDUSTRIEBEDARF / SUMINISTROS INDUSTRIALES

Bolt for Plywood

Torx-Selbstschneidschrauben Dacromet

Tornillo Alas fijación pisos madera

Ref	Kg	Mat	Col	A	B	Metric	Lot	Pack
2521011	12.5	STEEL	●	60	15	M6,3	1	1000
2521012	11.5	STEEL	●	60	12	M6,3	1	1000
2521013	6.5	STEEL	●	50	12	M5,5	1	1000

Finish: DACROMET
Acabado: DACROMET

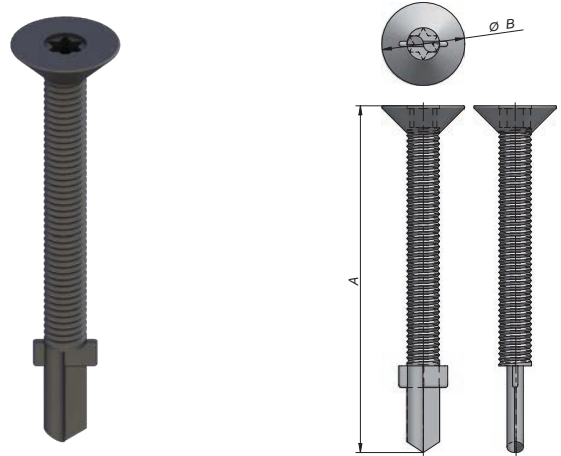

Screwdriver Bit S2 T30

Torx Schrauberbit S2 T30

Punta de atornillar S2 T30

Ref	Kg	Mat	Lot
2521090	0.01	STEEL	10



Screwdriver Bit Torx27 for 2521010

Bohrer S2 Torx27 für 2521010

Punta de atornillar Torx27 Larga para 2521010

Ref	Kg	Mat	Lot
2521094	0.01	STEEL	10



Bolt Edestahl 5X25

Schraube 5x25 Edelstahl

Tornillo Zócalo Inox 5x25

Ref	Kg	Mat	Lot	Pack
2521016	3	INOX	1	1000

Panhead screw 12mm | Panel Fixing - Wood | Soft and Hardwood Drill |
Tightening torque: 29 Kgxcmm | Breaking torque: 15.50 Kgxcmm | Hollow Head Torx20
Cabeza Alomada 12 mm | Fijación de Panel-Madera | Taladra Madera Blanda y Dura |
Par Apriete: 29 Kgxcmm | Par Ruptura: 15,50 Kgxcmm | Cabeza Hueco torx20

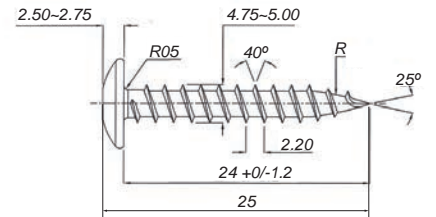
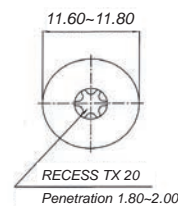



DISCS / DISCOS









NEW

BENEFITS / VENTAJAS

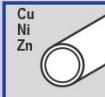
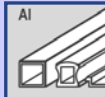
- ✓ The highest cutting speed in the market.
La mayor velocidad de corte del mercado.
- ✓ Time saving.
Ahorro tiempo de trabajo.
- ✓ Fine finishing.
Acabados finos.
- ✓ Multiple applications for the commercial vehicle (Steel, aluminium, polyester,...).
Múltiples aplicaciones para vehículo industrial (acero, aluminio, poliéster,...).
- ✓ Excellent ergonomomy (low vibration)
Excelente ergonomía (menor vibración).
- ✓ Available in diameters 115, 125 & 180 mm.
Disponibles en diámetros 115, 125 y 180 mm.
- ✓ ADAICO QUALITY guaranteed.
Calidad garantizada por ADAICO.

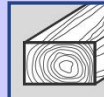
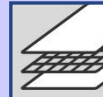
Applications Aplicaciones

								
Stainless Steel <i>Acero Inoxidable</i>	Unalloyed Steel <i>Acero no aleado</i>	Non ferrous metals <i>Metales no férricos</i>	Aluminium <i>Aluminio</i>	Super Alloys <i>Super Aleaciones</i>	Wood <i>Madera</i>	Polyester <i>Poliéster</i>	Lacquer <i>Pintura</i>	Glass <i>Cristal</i>

**DISCO CORTE
CUTTING DISC**



Cutting Disc PRO Metal
Trennscheiben PRO Metal
Disco Corte PRO Metal

NEW

Ref	Kg	Ø	Thickn. Espesor	Article	Pack
0471115	0.7	Ø115	1	Máx RPM: 13300 min-1 Flat Máx RPM: 13300 min-1 Plano	25
0471231	0.85	Ø230	2	Máx RPM: 6650 min-1 Conical Máx RPM: 6650 min-1 Cóncavo	25

Fast cutting speed (80 m/s) and consistent performance | An aggressive and functional line of products for general daily use
Velocidad de corte rápida (80 m/s) y un rendimiento constante | Una línea de productos agresiva y funcional para uso diario en general
EN 12413



Cutting Disc PRO Inox/Metal
Trennscheiben PRO Inox/Metal
Disco Corte PRO Inox/Metal

NEW

Ref	Kg	Ø	Thickn. Espesor	Article	Pack
0471116	0.7	Ø115	1	Máx RPM: 13300 min-1 Flat Máx RPM: 13300 min-1 Plano	25
0471125	0.8	Ø125	1	Máx RPM: 12250 min-1 Flat Máx RPM: 12250 min-1 Plano	25
0471230	0.85	Ø230	2	Máx RPM: 6650 min-1 Conical Máx RPM: 6650 min-1 Cóncavo	25

Fast cutting speed (80 m/s) and consistent performance | An aggressive and functional line of products for general daily use
Velocidad de corte rápida (80 m/s) y un rendimiento constante | Una línea de productos agresiva y funcional para uso diario en general
EN 12413



Cutting Disc PREMIUM Inox/Metal
Trennscheiben PREMIUM Inox/Metal
Disco Corte PREMIUM Inox/Metal

NEW

Ref	Kg	Ø	Thickn. Espesor	Article	Pack
0470115	0.75	Ø115	1	Máx RPM: 13300 min-1	25
0470125	0.85	Ø125	1	Máx RPM: 12250 min-1	25

Flat | Speed: 80 m/s | Fine cut (precise and clean) | double reinforcement | Contaminant-free (stainless steel) | outer layer smooth | Superior cutting rate and useful life
Plano | Velocidad (80 m/s) | Corte fino (preciso y limpio) | doble refuerzo | Libre contaminantes (inoxidable) | Capa ext. lisa | Vida útil y tasa corte superior
EN 12413



Cutting Disc PREMIUM ULTRA CUT Inox/Metal
Trennscheiben PREMIUM ULTRA CUT Inox/Metal
Disco Corte PREMIUM ULTRA CUT Inox/Metal

NEW

Ref	Kg	Ø	Thickn. Espesor	Article	Pack
0472115	1.25	Ø115	1	Máx RPM: 13300 min-1	25
0472125	0.8	Ø125	1	Máx RPM: 12250 min-1	25

Flat | Ultra-fast cutting speed (80 m/s) | Long life | Burr Reduction | Consistency | Greater Stability
Plano | Velocidad de corte ultrarrápida | Larga Vida | Reducción de Rebabas | Consistencia | Mayor Estabilidad



**DISCO DESBASTE
GRINDING DISC**

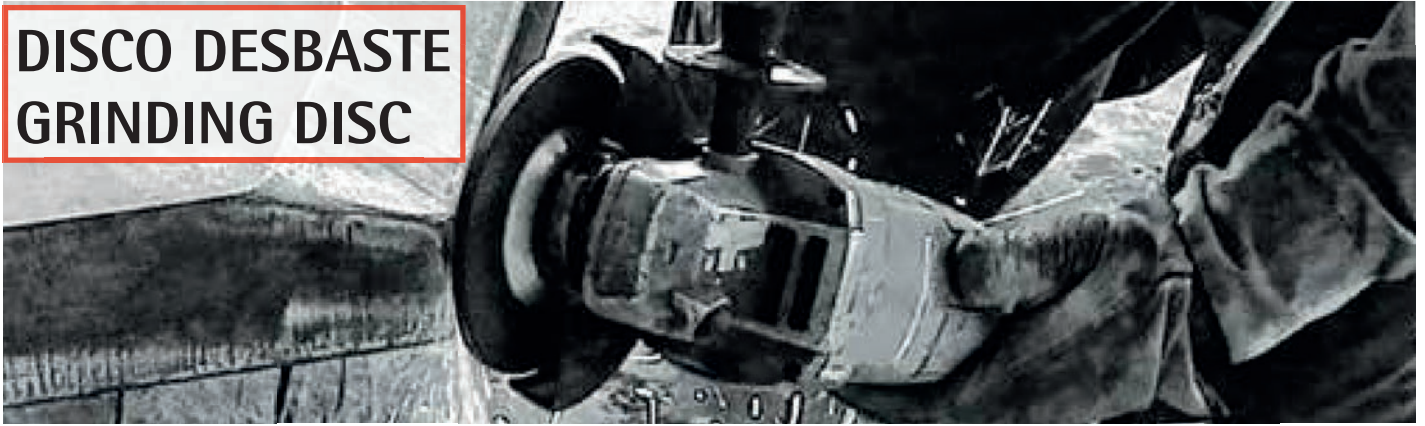

Grinding Disc PRO Metal
Schruppscheiben PRO Metal
Disco Desbaste PRO Metal

NEW

Ref	Kg	Ø	Thickn. Esesor	Article	Pack
0460115	1.55	Ø115	6.5	Máx RPM: 13300 min-1	10
0460125	1.85	Ø125	6.5	Máx RPM: 12250 min-1	10
0460180	3.75	Ø180	6.5	Máx RPM: 8500 min-1	10

Conical | Speed: 80 m/s | Grinding fast in metal
Cóncavo | Velocidad (80 m/s) | Desbaste rápido en metal
EN 12413



Grinding Disc PREMIUM Inox/Metal
Schruppscheiben PREMIUM Inox/Metal
Disco Desbaste PREMIUM Inox/Metal

NEW

Ref	Kg	Ø	Thickn. Esesor	Article	Pack
0461115	1.8	Ø115	7	Máx RPM: 13300 min-1	10
0461125	2	Ø125	7	Máx RPM: 12250 min-1	10

Conical | Speed: 80 m/s | Grinding fast in metal
Cóncavo | Velocidad (80 m/s) | Desbaste rápido en metal
EN 12413

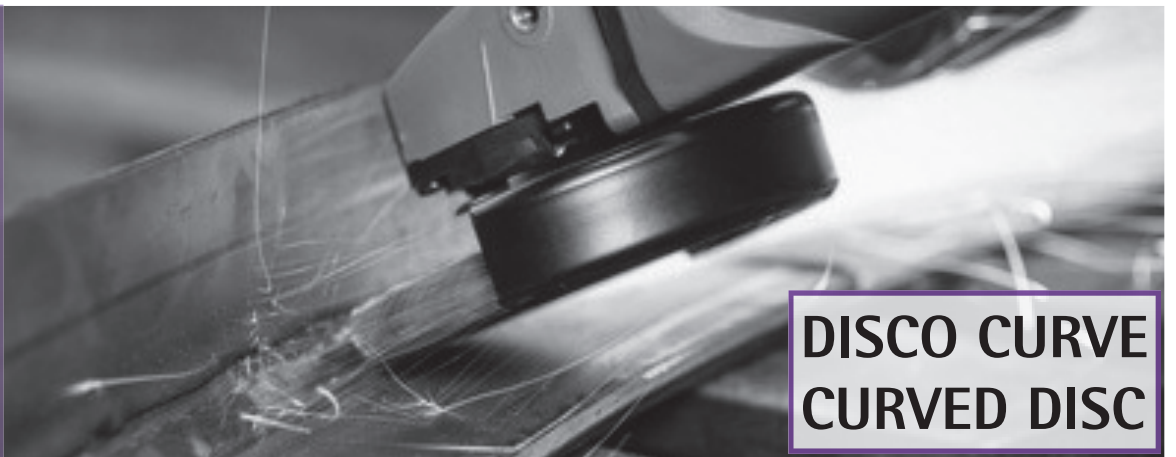
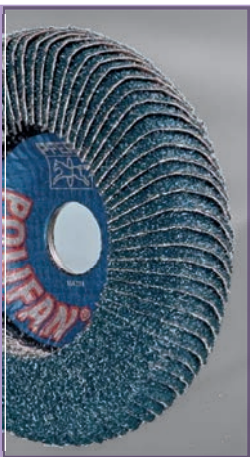
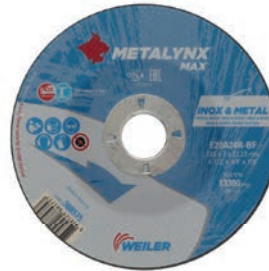

**DISCO CURVE
CURVED DISC**

Flap Disc Zirconio "CURVE"
Flächerscheiben Zirconio "CURVE"
Disco Láminas Zirconio "CURVE"

NEW

Ref	Kg	A	Ø	Article	Pack
0445540	1.16	40	Ø125	Máx RPM: 12200 min-1	10

Steel&Stainless | Angle machining, welding removal, edging and deburring | High chip removal capacity. Fast roughing. Cost savings
Acero&Inox | Mecanizado en ángulo, eliminación soldadura, canteado y desbarbado | Alta capacidad arranque virutas. Desbaste rápido. Ahorro costes
EN 13743





**DISCO LÁMINAS
FLAP DISC**

Flap Disc PRO Inox/Metal Zirconio
Flächerscheiben PRO Inox/Metal Zirconio
Disco Láminas PRO Inox/Metal Zirconio

Ref	Kg	A	Ø	Article	Pack
0441540	1	40	Ø115	Máx RPM: 13300 min-1	10
0441560	1	60	Ø115	Máx RPM: 13300 min-1	10
0441580	1	80	Ø115	Máx RPM: 13300 min-1	10
0442540	1	40	Ø125	Máx RPM: 12250 min-1	10
0442560	1	60	Ø125	Máx RPM: 12250 min-1	10
0442580	1	80	Ø125	Máx RPM: 12250 min-1	10



Conical | Speed: 80 m/s | Contaminant-free (-0.1% Fe, S, Cl) | Extremely long life and shortest grinding time, maximize productivity
Cóncavo | Velocidad (80 m/s | Rendimiento, consistencia y confiabilidad al desbastar y dar acabado al metal | Libre de contaminantes, menos del 0,1% de hierro, azufre y cloro
EN 13743

Flap Disc Steel/Stainless Steel ADVANCE
Flächerscheiben Stahl/Edelstahl ADVANCE
Disco Láminas Acero/Inox ADVANCE

NEW

Ref	Kg	A	Ø	Article	Pack
0443540	1.02	40	Ø115	Máx RPM: 13300 min-1	10
0443560	0.94	60	Ø115	Máx RPM: 13300 min-1	10
0443580	0.94	80	Ø115	Máx RPM: 13300 min-1	10
0444540	1.12	40	Ø125	Máx RPM: 12250 min-1	10
0444560	1.07	60	Ø125	Máx RPM: 12250 min-1	10
0444580	1.02	80	Ø125	Máx RPM: 12250 min-1	10



Conical | Speed: 80 m/s | Higher productivity (useful life + speed) | Fast and cold grinding (> work, > speed) | Contaminant-free (- 0.1% iron, sulfur and chlorine)
Cóncavo | Velocidad (80 m/s | Mayor productividad (vida útil+velocidad) | Desbaste rápido y en frío (> trabajo, > rapidez) | Libre contaminantes(- 0,1% de hierro, azufre y cloro)
EN 13743



Fiber Disc Ceramic
Keramik-Fiberscheiben
Disco Fibra Cerámico

Ref	Kg	A	Ø	Pack
0431560	1.31	60	Ø115	50
0431580	1.31	80	Ø115	50
0432560	1.42	60	Ø125	50
0432580	1.42	80	Ø125	50
0438080	2.05	80	Ø180	50

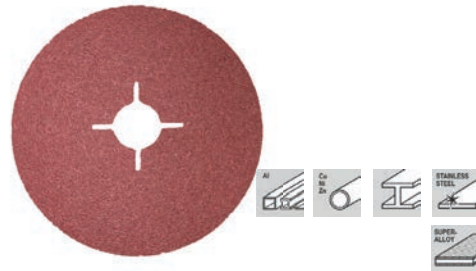

Grit: Ceramic | Bracking: Vulcanised fibre | Optimus: Unalloyed Steel and Stainless Steel | Suitable: Superalloys, Aluminium y NF-metals | EN 13743
Grano: Cerámico | Soporte: fibra vulcanizada | Óptimo: Acero no aleado y Acero Inoxidable | Adecuado: Superaleaciones, Aluminio y metales no férricos | EN 13743

Fiber Disc Ceramic PLUS
Keramik-Fiberscheiben PLUS
Disco Fibra Cerámico PLUS

Ref	Kg	A	Ø	Pack
0411536	1.31	36	Ø115	50
0412536	1.42	36	Ø125	50
0418036	2.05	36	Ø180	50

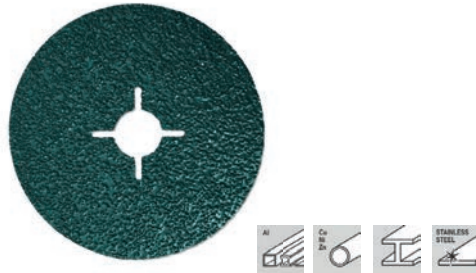

Grit: Ceramic | Bracking: Vulcanised fibre | Optimus: Unalloyed Steel | Suitable: Stainless Steel, Aluminium and NF-Metals | EN 13743
Grano: Cerámico | Soporte: fibra vulcanizada | Óptimo para Acero no aleado | Adecuado también para Acero Inoxidable, Aluminio y metales no férricos | EN 13743

Fiber Disc - Special ALUMINIUM
Fiberscheiben - speziell für ALUMINIUM
Disco Fibra - Especial ALUMINIO

Ref	Kg	A	Ø	Pack
0421536	0.15	36	Ø115	50
0421560	1.48	60	Ø115	50
0421580	1.48	80	Ø115	50
0422536	1.42	36	Ø125	50
0422560	1.48	60	Ø125	50
0422580	1.42	80	Ø125	50
0428036	2.05	36	Ø180	50
0428080	2.05	60	Ø180	50



Grit: Ceramic | Bracking: Vulcanised fibre | Optimus: Unalloyed Steel, Aluminium, NF-Metals | Suitable: Wood, Composite materials, Lacquer
Grano: Cerámico | Soporte: fibra vulcanizada | Óptimo: Acero no aleado, Aluminio y metales no férricos | Adecuado: Madera, materiales compuestos, pintura | EN 13743

Disc - Silicon Carbide, Special for POLYESTER
Scheiben - Siliziumkarbid, speziell für POLYESTER
Disco Carburo Silicio Especial POLIÉSTER

Ref	Kg	A	Ø	Pack
0451524	1.48	80	Ø115	50
0452524	1.48	24	Ø125	50

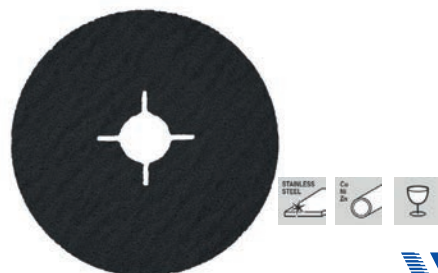

Grit: Silicon Carbide | Bracking: Vulcanised fibre | Optimus: Stainless Steel, NF-Metals, Glass-Stone-Ceramic | Suitable: Angle Grinder
Grano: Carburo de Silicio | Soporte: fibra vulcanizada | Óptimo: Acero Inoxidable, metales no férricos, vidrio-piedra-cerámica | Adecuado: Lijadora radial



Support Disc Medium
 Platte Mittel
 Plato Soporte Medio

Ref	Kg	Ø	Metric	Article
0411500	0.09	Ø115	M14	Grit: Medium Grano Medio
0412500	0.1	Ø125	M14	Grit: Medium Grano Medio
0418000	0.14	Ø180	M14	Grit: Medium Grano Medio

EN 13743



Support Disc Hard
 Platte Hard
 Plato Soporte Duro

Ref	Kg	Ø	Metric	Article
0411501	0.09	Ø115	M14	Grit: Hard Grano Duro
0412501	0.1	Ø125	M14	Grit: Hard Grano Duro
0418001	0.14	Ø180	M14	Grit: Hard Grano Duro

EN 13743



Flexible Tube Support Disc
 Platte Flexibles Rohr
 Plato Soporte Tubo Flexible

Ref	Kg	Ø	Metric
0411502	0.09	Ø115	M14
0412502	0.09	Ø125	M14
0418002	0.09	Ø180	M14

ISO 15636



Battery Rivet Gun IERO 5.0 (Rivets)
Nietpistole Batterie 5.0 (Niete)
Remachadora Bateria IERO 5.0 (Remaches)

Ref	Kg	V	Article	Lot
2880001	2.15	18v	1xBattery 1xBatería	1
2880002	2.51	18v	2xBatteries 2xBaterías	1

Application: Steel/Alu/Stainless Steel=Ø2.4-Ø5.0 | Setting Force: 12kn | Working Stroke: 21mm. |
Direct current motor: 18V
Aplicación: Acero/Alu/Inox=Ø2.4-Ø5.0 | Fuerza Tracción: 12kn | Carrera: 21mm. |
Motor de corriente: 18V
Certificado CE



Colector de vástagos
Nail collector



Ø2,4mm - Ø5,0mm
Acero / Aluminio / A2
Steel / Aluminium / Stainless Steel

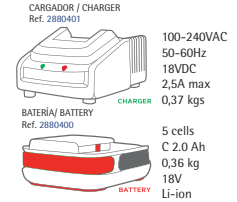

CARGADOR / CHARGER
Ref. 2880401
100-240VAC
50-60Hz
18VDC
2,5A max
0,37 kgs

BATERIA/ BATTERY
Ref. 2880400
5 cells
C 2.0 Ah
0,36 kg
18V
Li-ion

Battery Rivet Gun IERO 6.0 (Rivets)
Nietpistole Batterie 6.0 (Niete)
Remachadora Bateria IERO 6.0 (Remaches)

Ref	Kg	Article	Lot
2880004	2.15	2xBatteries 2xBaterías	1

Application: Steel/Alu/Stainless Steel=Ø4.8-Ø6.4 | Setting Force: 20kn | Working Stroke: 25mm. |
Direct current motor: 18V
Aplicación: Acero/Alu/Inox=Ø4.8-Ø6.4 | Fuerza Tracción: 20kn | Carrera: 25mm. |
Motor de corriente: 18V
Certificado CE

NEW



Colector de vástagos
Nail collector

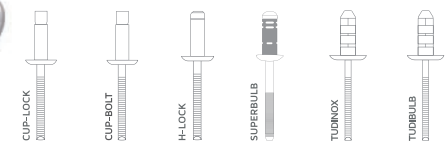

Ø4,8mm - Ø6,4mm
Acero / Aluminio / A2
Steel / Aluminium / Stainless Steel

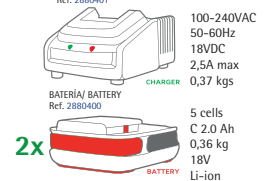

CARGADOR / CHARGER
Ref. 2880401
100-240VAC
50-60Hz
18VDC
2,5A max
0,37 kgs

BATERIA/ BATTERY
Ref. 2880400
5 cells
C 2.0 Ah
0,36 kg
18V
Li-ion

Battery Rivet Gun IERO 7.0 (Lock Bolts)
Nietpistole Batterie 7.0 (Sperrbolzen)
Remachadora Bateria IERO 7.0 (Pernos)

Ref	Kg	Article	Lot
2880003	2.26	2xBatteries 2xBaterías	1

Application: Steel/Alu=Ø4.8-Ø6.0 | Setting Force: 23kn | Working Stroke: 19mm. |
Direct current motor: 18V | Tool Nozzle piece not included
Aplicación: Acero/Alu=Ø4.8-Ø6.0 | Fuerza Tracción: 23kn | Carrera: 19mm. |
Motor de corriente: 18V | Boquilla no incluida
Certificado CE

NEW



*Sin Boquilla
Without Nose

Colector de vástagos
Nail collector

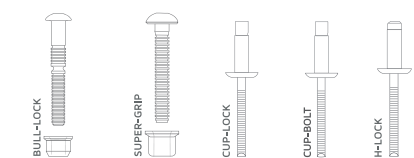

Ø4,8mm - Ø6,4mm
Acero / Aluminio / A2
Steel / Aluminium / Stainless Steel

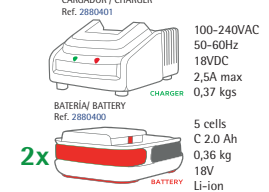

CARGADOR / CHARGER
Ref. 2880401
100-240VAC
50-60Hz
18VDC
2,5A max
0,37 kgs

BATERIA/ BATTERY
Ref. 2880400
5 cells
C 2.0 Ah
0,36 kg
18V
Li-ion

Tool Nozzle for Riveting IERO 7.0/MAX70
Nietpistoledüse IERO 7.0/MAX70
Boquilla p/Remachadora batería IERO 7.0/MAX70

Ref	Kg	Metric	Article	Lot
2880248	0.14	4.8	for Bull Lock p/Bull Lock	1
2880264	0.14	6.4	for Bull Lock p/Bull Lock	1
2880348	0.14	4.8	for Lock Bolt Supergrip p/Lock Bolt Supergrip	1
2880364	0.14	6.4	for Lock Bolt Supergrip p/Lock Bolt Supergrip	1

NEW





MACHINES AND ACCESSORIES / MASCHINEN UND ZUBEHÖR / MÁQUINA Y ACCESORIOS

INDUSTRIAL SUPPLIES / INDUSTRIEBEDARF / SUMINISTROS INDUSTRIALES

Battery for Rivet Gun IERO
 Batterie für Nietpistole IERO
 Bateria para Remachadora IERO

NEW

Ref	Kg	Article	Lot
2880400	0.36	Battery for 2880001/02/03/04 Remachadoras 2880001/02/03/04	1

Rated Voltage: 18V Li-ion- 2.0 Ah | Cells: 5 cells | Capacity: 2.0 Ah



IERO Rivet Gun Battery Charger
 Batterie Ladegerät Nietpistole IERO
 Cargador de Bateria para Remachadora IERO

NEW

Ref	Kg	Lot
2880401	0.37	1



Hydropneumatic Riveting Tool (4,8-6,4)
 Hydro-pneumatische Nietpistole (4,8-6,4)
 Remachadora Oleoneumática (4,8-6,4)

Ref	Kg	Lot
2880008	1.7	1

All alloys Ømm=4.8*/5.0/6.0/6.4* (*also structural) | Air consumption: 4,8l. | Setting Force: 18kn | Working Stroke: 26mm. | Operating Air Pressure: 5-7bar
 Todas aleaciones Ømm=4.8*/5.0/6.0/6.4* (*también estructurales) | Consumo aire: 4,8l. | Fuerza Tracción: 18kn | Carrera: 26mm. | Presión trabajo: 5-7bar
 Certificado CE



Ø4,8mm - Ø6,4mm
 Acero / Aluminio / A2
 Steel / Aluminium / Stainless Steel

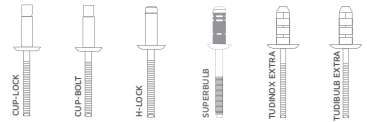

También Remaches Estructurales
 Also structural Rivets

Hydropneumatic Riveting Tool Nozzle
 Hydro-pneumatische Nietpistoledüse
 Boquilla repuesto remachadoras Neumáticas

Ref	Kg	Metric	Lot
2880148	0.01	4.8	1
2880160	0.01	6	1
2880164	0.01	6.4	1



Hydropneumatic Riveting Tool (Ø3,2-6,4)
Hydro-pneumatische Nietpistole (Ø3,2-6,4)
Remachadora Oleoneumática (Ø3,2-6,4)

NEW

Ref	Kg	Lot
2880007	1.3	1

All alloys Ømm.=3.2/4.0/4.8/5.0/6.0/6.4 | Air consumption: 2,6l. | Setting Force: 10kn | Working Stroke: 20mm. | Operating Air Pressure: 5-7bar
Aplicación: Todas aleaciones Ømm.=3.2/4.0/4.8/5.0/6.0/6.4 | Consumo aire: 2,6l. | Fuerza Tracción: 10kn | Carrera: 20mm. | Presion trabajo: 5-7bar
Certificado CE



Aspiración de vástago
Mandrel Aspiration

Ø3,2mm - Ø6,4mm
Acero / Aluminio / A2
Steel / Aluminium / Stainless Steel

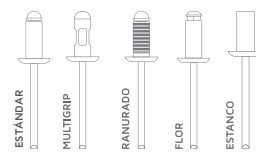

Hydropneumatic Riveting Tool (4-6,4)
Hydro-pneumatische Nietpistole (4-6,4)
Remachadora Oleoneumática (4-6,4)

Ref	Kg	Lot
2880009	1.3	1

All alloys Ømm=4.0/4.8/5.0/6.0/6.4 | Air consumption: 1,6l. | Setting Force: 10kn | Working Stroke: 20mm. | Operating Air Pressure: 5-7bar
Todas aleaciones Ømm=4.0/4.8/5.0/6.0/6.4 | Consumo aire: 1,6l. | Fuerza Tracción: 10kn | Carrera: 20mm. | Presion trabajo: 5-7bar
Certificado CE



Ø4,0mm - Ø6,4mm
Acero / Aluminio / A2
Steel / Aluminium / Stainless Steel

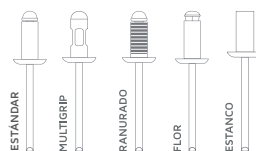

Hydropneumatic Riveting Tool (Ø2,4-5,0)
Hydro-pneumatische Nietpistole (Ø2,4-5,0)
Remachadora Oleoneumática (Ø2,4-5,0)

Ref	Kg	Lot
2880010	1.1	1

All alloys Ømm=2.4-4.0; Aluminium Ømm=2.4-5.0 | Air consumption: 1,6l. | Setting Force: 7Kn | Working Stroke: 18mm. | Operating Air Pressure: 5-7bar
Todas aleaciones Ømm=2.4-4.0 | Aluminio Ømm=2.4-5.0 | Consumo aire: 1,6l. | Fuerza Tracción: 7kn | Carrera: 18mm. | Presion trabajo: 5-7bar
Certificado CE



Aspiración de vástago
Mandrel Aspiration

Ø2,4mm - Ø5,0mm
Acero / Aluminio / A2
Steel / Aluminium / Stainless Steel

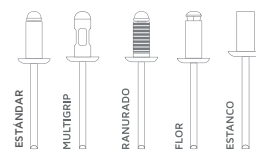

Pneumatic Riveting Tool for Nuts M4-M12
Pneumatische Nietpistole für Nietmutter M4-M12
Remachadora Neumática para tuercas M4-M12

NEW

Ref	Kg	Metric	Lot
2880012	2.46	M4-M12	1

For Rivet Nuts | All alloys M4 - M5 - M6 - M8 - M10 - M12 | Setting Force: 30kn | Working Stroke: 7mm. | Operating Air Pressure: 5-7bar
Para tuercas | Todas aleaciones M4 - M5 - M6 - M8 - M10 - M12 | Fuerza Tracción: 30kn | Carrera: 7mm. | Presion trabajo: 5-7bar
Certificado CE



¡RÁPIDO CAMBIO DE UTILLAJE!
QUICK TOOL CHANGE!

M3 - M12
Acero / Aluminio / A2
Steel / Aluminium / Stainless Steel

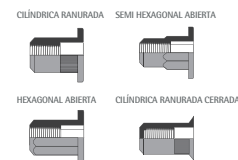

REGULADOR DE PRESIÓN
PRESION REGULATOR





MACHINES AND ACCESSORIES / MASCHINEN UND ZUBEHÖR / MÁQUINA Y ACCESORIOS

INDUSTRIAL SUPPLIES / INDUSTRIEBEDARF / SUMINISTROS INDUSTRIALES

Pneumatic Riveting Tool for Nuts M3-M12
Pneumatische Nietpistole für Nietmutter M3-M12
Remachadora Neumática para tuercas M3-M12

Ref	Kg	Metric	Lot
2880013	2.46	M3-M12	1

For Rivet Nuts | All alloys M3 - M4 - M5 - M6 - M8 - M10 - M12 | Setting Force: 30kn | Working Stroke: 7mm. | Operating Air Pressure: 5-7bar
Para tuercas | Todas aleaciones M3 - M4 - M5 - M6 - M8 - M10 - M12 | Fuerza Tracción: 30kn | Carrera: 7mm. | Presion trabajo: 5-7bar
Certificado CE



¡PIEZAS UNIVERSALES!
UNIVERSAL PIECES!

M3 - M12
Acero / Aluminio / A2
Steel / Aluminium / Stainless Steel

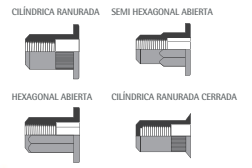

REGULADOR DE PRESIÓN
PRESION
REGULATOR



Pneumatic Riveting Tool MAX70
Pneumatische Nietpistole MAX70
Remachadora Neumática MAX70

Ref	Kg	Lot
2880014	2.9	1

Alu-Steel-St Steel | Ømm.=4.8-9.8 | Air consumption: 4,8l. | Setting Force: 28-39kn | Working Stroke: 17mm. | Operating Air Pressure: 5-7bar | Set not included (the same Adapter IERO 7.0)
Aluminio-Acero-Inox | Ømm.=4.8-9.8 | Consumo aire: 4,8l. | Fuerza Tracción: 28-39kn | Carrera: 17mm. | Presion trabajo: 5-7bar | Kit no incluido (mismo adaptador que IERO 7.0)
Certificado CE



NEW

Ø4,8mm - Ø9,8mm
Acero / Aluminio / A2
Steel / Aluminium / Stainless Steel

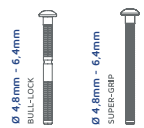

Pneumatic Riveting Tool MAX100 for ADAPLY
Pneumatische Nietpistole MAX100 für ADAPLY
Remachadora Neumática MAX100 para remache ADAPLY

Ref	Kg	Lot
2880015	5.5	1

Alu-Steel-St Steel | Ømm.=6.4-9.8 | Air consumption: 8,4l. | Setting Force: 30,6-42,84kn | Working Stroke: 22mm. | Operating Air Pressure: 5-7bar | set not included
Aluminio-Acero-Inox | Ømm.=6.4-9.8 | Consumo aire: 8,4l. | Fuerza Tracción: 30,6-42,84kn | Carrera: 22mm. | Presion trabajo: 5-7bar | Kit no incluido
Certificado CE



NEW

Ø6,4mm - Ø9,8mm
Acero / Aluminio / A2
Steel / Aluminium / Stainless Steel

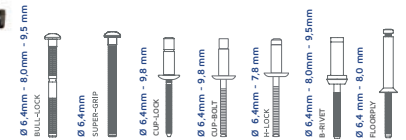

ADAPLY Set for Pneumatic Riveting Tool MAX100
ADAPLY Set für Pneumatische Nietpistole MAX100
Kit ADAPLY p/Remachadora Neumática MAX100

Ref	Kg	Lot
2880564	0.14	1



NEW



Hand Tool for Rivet
Manuelle-Nietmaschine
Remachadora Manual de Alicates



Ø2,4mm - Ø4,8mm
Acero / Aluminio
Steel / Aluminium

Ref	Kg	Lot
2880005	0.53	1

Application: Aluminium Ømm=2.4/3.2/4.0/4.8 | Steel Ømm=2.4/3.2/4.0
Aplicación: Aluminio Ømm=2.4/3.2/4.0/4.8 | Acero Ømm=2.4/3.2/4.0



Two Hand Rivet Tool
Hebel-Nietmaschine
Remachadora Manual de Palanca



Ø3,2mm - Ø6,4mm
Acero / Aluminio / A2
Steel / Aluminium / Stainless Steel

Ref	Kg	Lot
2880006	1.81	1

Application: Aluminium Ømm=3.0/4.0/5.0/6.0/6.4 / All alloys Ømm=3.0/4.0/5.0/6.0/6.4
Aplicación: Aluminio Ømm=3.0/4.0/5.0/6.0/6.4 / Todas aleaciones Ømm=3.0/4.0/5.0/6.0/6.4

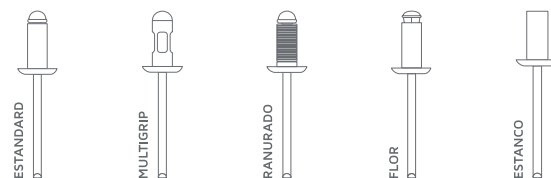

Two Hand Rivet Tool for Rivet Nuts
Hebel-Nietmaschine für Nietmutter
Remachadora Manual Palanca para Tuercas Remachables

NEW



Ref	Kg	Metric	Lot
2880011	2.2	M3-M10	1

Application: All alloys M3-M4-M5-M6-M8-M10
Aplicación: Todas aleaciones M3-M4-M5-M6-M8-M10
Certificado CE



MACHINES AND ACCESSORIES / MASCHINEN UND ZUBEHÖR / MÁQUINA Y ACCESORIOS

INDUSTRIAL SUPPLIES / INDUSTRIEBEDARF / SUMINISTROS INDUSTRIALES

Eco magnetic core drill for up to 32 mm
Eco-Magnet-Kernbohrmaschine bis 32 mm
Máquina perforadora con imán Eco hasta 32 mm

NEW

Ref	Kg	Article	Lot
0480031	17.34	Including: hand pump bottle holder lashing strap centring pin 100 mm contact guard socket head wrench 5 mm. Incluye: bomba de lubricación manual soporte para botellas correa de amarre centrador de 100 mm protección contra contacto	1

Small and powerful single-speed universal magnetic core drill with clockwise/anti-clockwise operation | maximum functionality for flexible working
Máquina perforadora con imán Eco de 1 velocidad | pequeña y ligera | funcionalidad básica para la perforación con corona



Universal magnetic core drill for up to 35 mm
Universal-Magnet-Kernbohrmaschine bis 35 mm
Máquina perforadora con imán universal hasta 35 mm

NEW

Ref	Kg	Article	Lot
0480032	17.15	Including: coolant tank lashing strap swarf hook centering pin contact guard Incluye: depósito de refrigerante correa de amarre gancho para virutas centrador protección contra contacto	1

Small and powerful single-speed universal magnetic core drill with clockwise/anti-clockwise operation | maximum functionality for flexible working
Con imán universal ligera y carrera extra larga de 1 velocidad con giro a derecha/izquierda | máxima funcionalidad para trabajar de forma flexible



Compact magnetic core drilling machine 36 mm
Compact-Magnet-Kernbohrmaschine bis 36 mm
Máquina perforadora con imán compacta hasta 36 mm

NEW

Ref	Kg	Article	Lot
0480030	14.25	1/2" ratchet Key extension 5 mm Allen key 5 mm T key cooler pump protection clamp auxiliary grip Incluye: trinquete de 1/2" prolongación de llave llave Allen 5 mm llave T 5 mm bomba refrigerante protección amarre puño auxiliar	1

The smallest on the market (L290xH169xW154) | Ideal for work in confined spaces
La más pequeña del mercado (L290xH169xW154) | Idónea para trabajos en espacios reducidos



HSS Special 25 Core Bit with 3/4 in Fitting
 HSS Special 25 Kernbohrer mit 3/4 In Aufnahme
 Corona perforadora HSS Especial con alojamiento 3/4"

NEW

Ref	Kg	Ø	Article	Lot
0480213	0.08	Ø13	Cutting depth 25 mm Profundidad corte 25 mm	1
0480215	0.08	Ø15	Cutting depth 25 mm Profundidad corte 25 mm	1
0480217	0.09	Ø17	Cutting depth 25 mm Profundidad corte 25 mm	1
0480220	0.1	Ø20	Cutting depth 25 mm Profundidad corte 25 mm	1
0480222	0.1	Ø22	Cutting depth 25 mm Profundidad corte 25 mm	1

Long service life. For drilling multi-layered materials in a single process
 Gran duración. Para la perforación de materiales de varias capas en un solo paso de trabajo



Carbide Core Drill Bit with Holder
 Hm-Kernbohrer mit Aufnahme
 Corona perforadora con alojamiento

NEW

Ref	Kg	Ø	Article	Lot
0480415	0.08	Ø15	Cutting depth 20 mm Profundidad corte 20 mm	1
0480417	0.11	Ø17	Cutting depth 20 mm Profundidad corte 20 mm	1

Outstanding cutting performance in all common metals.
 Máxima duración gracias al dentado de metal duro | Rendimiento de arranque de virutas excelente en todos los metales usuales



TCT ULTRA 35 Core Bit with Holder
 HM ULTRA 35 Kernbohrer mit Aufnahme
 Corona perforadora ULTRA Metal Duro con alojamiento

NEW

Ref	Kg	Ø	Article	Lot
0480120	0.09	Ø15	Cutting depth 35 mm Profundidad corte 35 mm	1

Very long service life and outstanding cutting performance | Metric dimensions, cutting depth 35 mm.
 Máxima resistencia y excelente rendimiento de arranque de virutas. Dimensiones métricas, profundidad de corte 35 mm.





MACHINES AND ACCESSORIES / MASCHINEN UND ZUBEHÖR / MÁQUINA Y ACCESORIOS

INDUSTRIAL SUPPLIES / INDUSTRIEBEDARF / SUMINISTROS INDUSTRIALES

Universal two-speed drill, up to 13 mm
Zweigang-Bohrmaschine bis 13 mm
Taladro de dos velocidades hasta 13 mm

NEW



Ref	Kg	Article	Lot
0480050	4.89	Including: single sheath metal quick clamping drill chuc additional handle Incluye: portabrocas de sujeción rápida puño auxiliar	1

Universal two-speed drill, up to 13 mm with ideal speed range for steel and stainless steel |
For metric screwdriving applications up to M27
Taladro de 2 velocidades universal hasta 13 mm con velocidad ideal para acero y acero inoxidable

Two-Speed Hand Drill up to 16 mm
Zweigang-Bohrmaschine bis 16 mm
Taladro de dos velocidades hasta 16 mm

NEW



Ref	Kg	Article	Lot
0480051	5.6	Including: single sheath metal quick clamping drill chuc additional handle Incluye: portabrocas de sujeción rápida puño auxiliar	1

Powerful two-speed drill with speed setting for flexible use in metal construction
Potente taladro de dos velocidades con ajuste de la velocidad para el uso flexible en la construcción metálica.



Compact Angle Grinder WSG 7-125 Câble 4 m
Kompakt Winkelschleifer WSG 7-125 Kabel 4 m
Amoladora Angular Compacta WSG 7-125 Cable 4 m

NEW



Ref	Kg	Ø	Article	Lot
0480712	1.8	125		1

for light grinding and cutting jobs | Including: 1 guard, 1 pair of flanges, 1 handle, 1 wrench
Para trabajos de desbaste y corte sencillos | Incluye: 1 cubierta protectora, 1 puño auxiliar, 1 pareja
bridas, 1 llave

Compact Angle Grinder CG 10-125 Câble 4 m
Kompakt Winkelschleifer CG 10-125 Kabel 4 m
Amoladora Angular Compacta CG 10-125 Cable 4 m

NEW



Ref	Kg	Ø	Article	Lot
0481012	2.1	125		1

for complex deburring, grinding, and cutting work | Including: 1 guard, 1 handle, 1 tool-free
quick-release nut, 1 wrench
Para trabajos de desbarbado, desbaste y corte | Incluye: 1 cubierta protectora, 1 empuñadura, 1
tuerca de banco rápida sin herramienta, 1 llave

Compact Angle Grinder Ø 125 mm
Kompakt Winkelschleifer Ø 125 mm
Amoladora angular compacta Ø 125 mm

NEW



Ref	Kg	Ø	Lot
0480912	2.2	Ø125	1

for complex deburring, grinding, and cutting work | Including: 2 guards, 1 handle, 1 tool-free
quick-release nut, 1 wrench
Para trabajos de desbarbado, desbaste y corte | Incluye: 2 cubiertas protectoras, 1 empuñadura, 1
tuerca de banco rápida sin herramienta, 1 llave

Wheel Guard Ø150 mm
Schutzhaube Ø150 mm
Cubierta Protectora para Amoladora angular Ø150 mm

NEW



Ref	Kg	Ø	Lot
0480913	0.15	Ø150	1

for serrated and roughing discs
para discos multiláminas y de desbaste



MACHINES AND ACCESSORIES / MASCHINEN UND ZUBEHÖR / MÁQUINA Y ACCESORIOS

INDUSTRIAL SUPPLIES / INDUSTRIEBEDARF / SUMINISTROS INDUSTRIALES

cordless angle grinder, Ø115 mm
Akku-Winkelschleifer Ø115 mm
Amoladora angular a batería Ø115 mm

NEW



Ref	Kg	Article	Lot
0480812	5.26	Battery not included Including: 1 Tool-free quick-clamping nut 1 key 1 protective cover for cutting work	1
		Batería no incluida Incluye: tuerca de banco rápida sin herramienta llave cubierta protectora para trabajos de tronzado	

Powerful cordless angle grinder with unique operating concept for particularly safe working
Amoladora angular a batería de gran potencia con un concepto de mando exclusivo para trabajar de forma especialmente segura

Cordless angle grinder, Ø125 mm
Akku-Winkelschleifer Ø125 mm
Amoladora angular a batería Ø125 mm

NEW



Ref	Kg	Ø	V	Article	Lot
0481122	5.81	125	18v	Battery not included includes: 1 protective cover 1 quick tightening nut without tools 1 anti-vibration handle 1 key	1
				Batería no incluida cubierta protectora Incluye: tuerca de banco rápida sin herramienta Empuñadura antivibración llave	

Dust-resistant and powerful, compact cordless angle grinder for effective cutting, grinding and deburring work in assembly jobs
Amoladora angular a batería resistente al polvo y de gran potencia para trabajos efectivos de corte, desbaste y desbarbado durante trabajos de montaje

2 Batteries Set 18V/4 AH + Charger
Set 2 Batterie 18V/4 AH mit Schnellladegerät
Set 2 Batería de iones de litio 18V/4 AH + Cargador

NEW



Ref	Kg	Lot
0480083	2.74	1

Special for Angle Grinder 0480812 | 2 Li-ion batteries with charge status indicato
Especial para Radial 0480812 | 2 baterías de iones de litio con cargador rápido

Magnetic vice with a jaw width of 100 mm
Magnetschraubstock mit Backenbreite von 100 mm
Mordaza imantada con anchura de mordaza 100 mm

NEW

Ref	Kg	Lot
0480100	9.17	1

Unique Market | Flexible | Perfect Setting: Pre-Magnetization 30% | Security | Open: 7,800 N (Thickness >4mm) | Modular, Adaptable | productivity
Única del mercado | Flexible | Ajuste perfecto: Pre-magnetización 30% | Seguridad | Agarre 7.800 N (espesor >4mm) | Modular, adaptable | Productividad



4-speed cordless drill/driver
4-Gang Akku-Bohrschrauber
Taladro atornillador a batería de 4 velocidades

Ref. 0480001
Set completo / Complete Set

NEW

Ref. 0480002
Solo taladro / Only drill



Ref	Kg	Article	Lot
0480001	7.34	Complete set, including: 2 batteries and charger Set completo, incluye: 2 baterías y cargador	1
0480002	4.07	Only Drill/Driver (no battery), including: 1 drill chuck (120 Nm); 1 belt clip; 1 magnetic bit storage; 1 handle Sólo Taladro (sin batería), incluye: 1 portabrocas (120 Nm); 1 gancho cinturón; 1 almacenaje para puntas de atornillado; 1 empuñadura	1

4-speed cordless drill/driver with brushless motor | for drilling and tapping up to 12 mm and drilling with carbide hole saws
Taladro atornillador a batería 4 velocidades con motor sin escobillas | Para taladrar y rosacar hasta 12 mm y taladrado con sierra de corona de metal

Bit Holder 1/4" Hexagonal
Bithalter 1/4" Hexagonal
Portapuntas 1/4" Hexagonal

NEW



Ref	Kg	Lot
0480006	0.12	1

1/4 in hexagon socket bit holder with convenient one-handed operation and powerful neodymium magnet
Portapuntas de hexágono 1/4" interior con práctico manejo con una sola mano y potente imán de neodimio

Tapping collet
Gewindebohr-Spannzange
Pinza Portapiezas para Roscado

NEW



Ref	Kg	Lot
0480007	0.15	1

Efficient thread tapping through reliable tapping drill hold | The tapping drill bit can be easily changed without the need for any tools
Perforación eficiente de roscas mediante la sujeción fiable de la roscadora; evita deslizamiento | Cambio cómodo y sin herramienta de la roscadora

Hole Saw Adapter
Lochsäge-Adapter
Adaptador para Sierra de Corona

NEW



Ref	Kg	Lot
0480009	0.45	1

To drill large holes | Perfectly suited to diameters of up to 40 mm.
Para perforar diámetros grandes | Óptimo hasta un diámetro de 40 mm.

Strong Metal Socket Adapter
Schwermetall Bohrfutter
Portabrocas Desmontable Mordaza para Metal Duro

NEW



Ref	Kg	Lot
0480011	0.46	1

Socket adapter to hold sockets with 1/2 in square holder
Portabrocas de mordazas planas con pretensado automático metálico Röhm | Capacidad de sujeción 1,5-13 mm. | Exactitud concéntrica (hasta 0,35 mm)

Angle Head
Winkelpopf
Cabezal Angular

NEW



Ref	Kg	Lot
0480005	0.48	1

for drilling, tapping and screwdriving in confined spaces | drill chucks, bit holders or socket adapters can be attached to the angled head
Cabezal angular metálico para perforar, rosacar y atornillar en espacios estrechos | Apto para portabrocas, portapuntas o adaptador para llave de paso

Drill Chuck
Bohrfutter
Portabrocas Desmontable

NEW



Ref	Kg	Lot
0480008	0.33	1

Solid metal drill chuck Röhm with carbide-tipped clamping jaws and high clamping forces | Maximum torque 120 Nm
Portabrocas metálico Röhm con garras de metal duro y fuerzas de sujeción elevadas. El portabrocas se desliza sobre la punta | Par máximo 120 Nm

Socket Adapter
Stecknussadapter
Adaptador para Llave de Paso

NEW



Ref	Kg	Lot
0480010	0.13	1

Socket adapter to hold sockets with 1/2 in square holder
Adaptador para utilizar llaves de vaso de 1/2" cuadrado



MACHINES AND ACCESSORIES / MASCHINEN UND ZUBEHÖR / MÁQUINA Y ACCESORIOS

INDUSTRIAL SUPPLIES / INDUSTRIEBEDARF / SUMINISTROS INDUSTRIALES

Cordless impact wrench/driver up to M18
Akku-Schlagschrauber bis M18
Llave de impacto a batería hasta M18

NEW

Ref	Kg	Article	Lot
0480040	3.55	Battery not included Including: belt clip magnetic bit storage Batería no incluida Incluye: gancho cinturón almacenaje para puntas de atornillado	1

Cordless impact wrench/driver with brushless motor and 6-stage torque setting | For metric screwdriving applications up to M18
Llave de impacto a batería con motor sin escobillas y ajuste del par en 6 niveles | Para atornillados métricos hasta M18



Cordless impact wrench/driver up to M27
Akku-Schlagschrauber bis M27
Llave de impacto a batería hasta M27

NEW

Ref	Kg	Article	Lot
0480041	5.33	Battery not included Batería no incluida	1

Cordless impact wrench/driver with brushless motor and 6-stage torque setting | For metric screwdriving applications up to M27
Llave de impacto a batería con motor sin escobillas y ajuste del par en 6 niveles | Para atornillados métricos hasta M27



2 Batteries Set 18V/6 AH + Charger
Set 2 Batterie 18V/6 AH mit Schnellladegerät
Set 2 Baterías de iones de litio 18V/6 AH + Cargador

NEW

Ref	Kg	Lot
0480082	3.27	1

2 Li-ion batteries with charge status indicato | Bluetooth® connectivity for connection to a mobile terminal and use with the myFEIN app
2 baterías de iones de litio con cargador rápido | Conectividad Bluetooth® para la conexión con terminal móvil y uso con la app myFEIN



Battery Quick Charger
Batterie Schnellladegerät
Cargador Rápido

NEW

Ref	Kg	Lot
0480080	1.05	1

high charge current of 8 amps | Large LED with charge state indicator and USB port
Tiempos de carga reducidos (8A) | Pantalla LED con indicador del nivel de carga y conexión USB



Battery 18V 6Ah
Batterie 18V 6Ah
Batería de iones de litio 18V 6Ah

NEW

Ref	Kg	V	Lot
0480081	0.77	18v	1

Li-ion battery with charge status indicato | Protects the battery and tool from overload, overheating and total discharge
Batería de iones de litio con indicador del nivel de carga | Protege la batería y la máquina frente a sobrecarga, sobrecalentamiento y descarga total



Oscillating Tool 700 mm
Oszillierer 700 mm
Herramienta oscilante 700 mm

NEW

Ref	Kg	Article	Lot
0480060	4.57	Including: protective cover for changing tools Hone Incluye: cubierta de protección para cambiar la herramienta piedra de afilar	1

Ideal for the automotive sector
Idónea para el sector de la automoción



Oscillating Tool 700 mm Special for crystals
Oszillierer 700 mm Speziell für Kristalle
Herramienta oscilante 700 mm Especial Lunas

NEW

Ref	Kg	Lot
0480061	4.94	1

Special for crystals | Wide range of accessories for the automotive and industrial vehicle sector
Especial para Lunas | Amplio equipamiento de accesorios para el sector de la automoción y vehículos industriales



Sheet metal shears up to 1.6 mm
Blechscherer bis 1.6 mm
Cizalla para chapa hasta 1.6 mm

NEW

ESPECIAL CORTE POLIÉSTER
SPECIAL FOR CUTTING POLYESTER
POUR COUPER LA PEAU POLYESTER

Ref	Kg	Article	Lot
0480070	3.01	Including: knife set 1 pair of keys 1 chip deflector Incluye: juego de cuchillas 1 pareja de llaves 1 deflector de virutas	1

Handy shears suitable for curves to cut and edge thin sheets
Cizalla manejable y apta en curvas para cortar y cantear chapas de poco grosor





ADAFLEX

Characteristics:

ADAFLEX is a mono-component elastomeric sealer based on polyurethane. It has high elasticity, good resistance to tearing and to the weather. After application, it polymerizes with the moisture from the air to form a flexible joint.

Características:

ADAFLEX es un sellador elastomérico monocomponente a base de poliuretano. Tiene alta elasticidad, buena resistencia al desgarro y a la intemperie. Después de la aplicación, polimeriza con la humedad del aire para formar una junta flexible.



Application:

ADAFLEX is recommended for joining and sealing in the field of industrial bodywork. It adheres without primer on the most common surfaces: anodized aluminum, lacquered metal, polyester, glass, etc. However, due to the great variety of surfaces and installation conditions, it is necessary to carry out preliminary tests on difficult materials (especially non-ferrous metals or lacquers and other plastic supports such as PVC, PMMA or ABS), where abrasion or the use of a primer will improve adhesion.

Aplicación:

ADAFLEX se recomienda para unir y sellar en el campo de la carrocería industrial. Se adhiere sin imprimación sobre las superficies más comunes: aluminio anodizado, metal lacado, poliéster, vidrio, etc. Sin embargo, debido a la gran variedad de superficies y condiciones de instalación, es necesario llevar a cabo pruebas preliminares en materiales difíciles (especialmente en metales no ferrosos o lacados y otros soportes de plástico como PVC, PMMA o ABS), donde la abrasión o el uso de una imprimación mejorarán la adhesión.

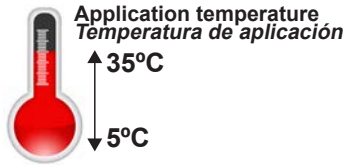
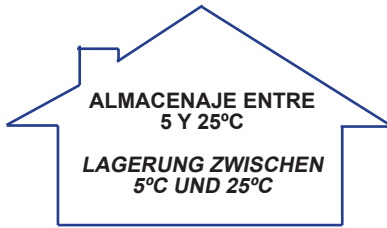

Specifications / Especificaciones:

Density at 20 ° C: Black: 1,15 ± 0,02 / Others: 1.16 ± 0.02
 Layer formation time at 23 ° C and 50% RH: approx. 50 min
 Crosslinking speed: at 23 ° C and 50% RH:> 3 mm / 24 h
 Shore A hardness (internal method IT-20 according to ISO 868 - 3 seconds): approx. 40
 Resistance to temperature: -40 to + 80 ° C
 Resistance to diluted acids and bases: Medium
 Resistance to UV rays: Good
 Resistance to water and salt spray: Excellent
 Compatibility with paints on polymerized mastic:
 - Water: Yes
 - Acrylics: necessary tests
 Specific data: Tear strength (ISO 34): approx. 8.5 N / mm.
 Module 100% (ISO 37): approx. 0.3 MPa
 Break module (ISO 37): approx. 1.4 MPa
 Breakage elongation (ISO 37): > 600%

Densidad a 20°C: Negro: 1,15 ± 0,02 / Otros: 1,16 ± 0,02
 Tiempo de formación de la capa a 23 ° C y 50 % HR: aprox. 50 min
 Velocidad de reticulación: a 23 ° C y 50 % HR: > 3 mm/24 h
 Dureza Shore A (método interno IT-20 según norma ISO 868 - 3 segundos): aprox. 40
 Resistencia a la temperatura: -40 à +80°C
 Resistencia a los ácidos y bases diluido: Media
 Resistencia a los rayos UV: Buena
 Resistencia al agua y niebla salina: Excelente
 Compatibilidad con pinturas sobre masilla polimerizada:
 - Al agua: Sí
 - Acrílicas: pruebas necesarias
 Datos específicos: Resistencia al desgarre (ISO 34): aprox. 8.5 N / mm.
 Módulo 100% (ISO 37): aprox. 0.3 MPa
 Módulo rotura (ISO 37): aprox. 1.4 MPa
 Alargamiento rotura (ISO 37): > 600%

Adaflex 12 Cartridge Box 300 ml.
 Adaflex Karton mit 12 Kartuschen 300 ml.
 Adaflex Caja 12 Cartuchos 300 ml.

Ref	Kg	Col	Cap.L	Lot
0402102	5		0.3	1
0402104	5		0.3	1
0402106	5		0.3	1



Adaflex 20 Sausage Box 600 ml.
 Adaflex Karton mit 20 Schlauchbeutel 600 ml.
 Adaflex Caja 20 Salchichas 600 ml.

Ref	Kg	Col	Cap.L	Lot
0402112	14.5		0.3	1
0402116	14.5		0.3	1
0402114	14.5		0.3	1



Butyl Rubber Band 28m.x55 e= 1mm.
 Butyl Kautschuk 28m.x55 e= 1mm.
 Rollo Butilo 28m.x55 e= 1mm.

Ref	Kg	Thickn. Espesor	Lot
0402140	2.1	1	1





Welding Wire Coil Steel ER70S-6
Schweissnaht Spule Stahl ER70S-6
Rollo Hilo Soldadura ER70S-6

Ref	Kg	Mat	Ø	Lot
0403004	15	STEEL	Ø0,8	1
0403006	20	STEEL	Ø1,0	1
0403008	20	STEEL	Ø1,2	1

ØInt: 52 mm. | Ø Ext: 270 mm. | Wide = 100 mm
ØInt: 52 mm. | Ø Ext: 270 mm. | Ancho = 100 mm



Sistemas de Sujeción de Carga

Load Fastening Systems

Systèmes d'Arrimage

Ladungssicherung

Sistema de Fixação de Carga

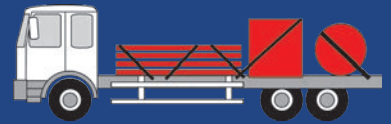

Amarres de Carga
Lashing Straps
Ensemble D'arrimage
Spanngurte
Cinta Amarração

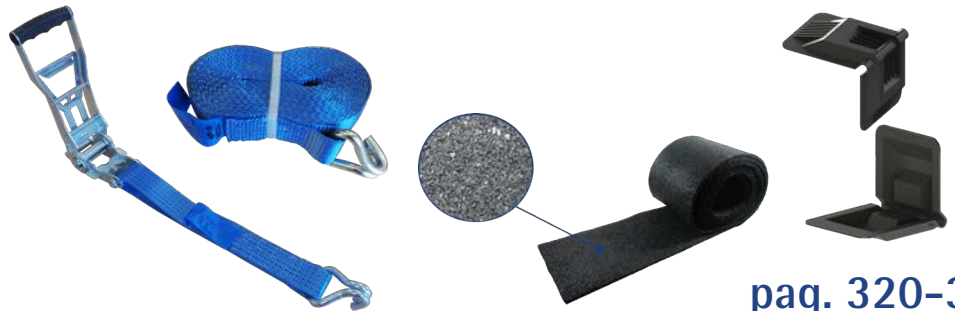

pag. 320-326

Perfiles de Carga
Loading Rails
Rampes de Chargement
Zurrschienen
Perfis de Carga



pag. 327-337

Barras de Carga
Load Safety Bars
Barres Antivol
Sicherheitsladestangen
Barras de Carga



pag. 338-345

Tensores de Cuerda
Rope Tensioners
Treuils
Seilspanner
Tensores de Corda

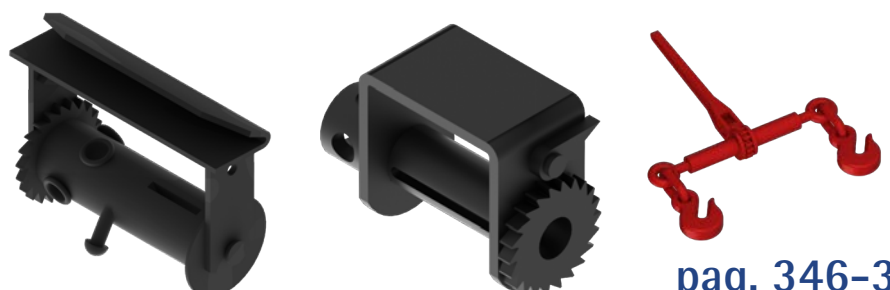

pag. 346-347

Argollas
Rings
Anneaux
Zurringe
Argolas

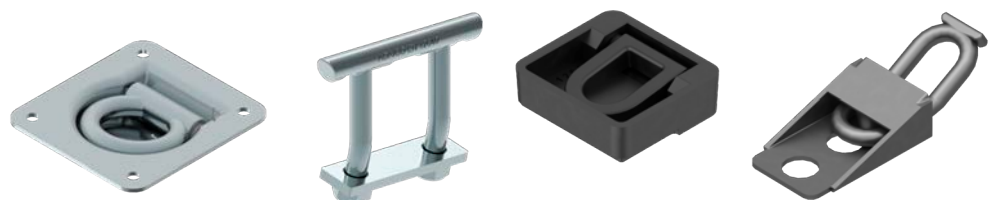

pag. 348-350



AMARRES DE CARGA LASHING STRAPS



Homologated Tension Strap 3.000 Kg.
Spanngurt 3.000 Kg. Annerkant
Zuncho 3.000 Kg. Homologado

Ref	Kg	Mat	Sup/Finish Acabado	Lot
2301025	1.3	GRP	Zn	1

Web: 6,8 (+0,5)m. x 3,8cm. | TF: 150daN | LC:1500-3000 daN | Double J Hook Ø9.3 mm. |
No for Lifting | 100% Polyester | Elongation of webbing (max): 7%
Cinta: 6,8 (+0,5)m. x 3,8cm. | TF: 150daN | LC:1500-3000 daN | Gancho J Doble Ø9.3 mm. |
No para elevación | 100% Poliéster | Elongación de cinta (máx): 7%
EN12195-2

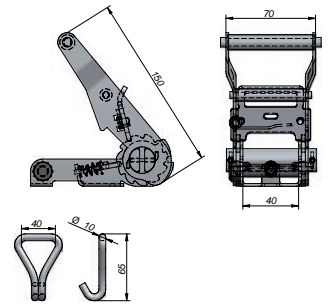

Homologated Tension Strap 2.000 Kg.
Spanngurt 2.000 Kg. Annerkant
Zuncho 2.000 Kg. Homologado

Ref	Kg	Mat	Sup/Finish Acabado	Lot
2301026	0.83	GRP	Zn	1

Web: 3,7 (+0,3)m. x 3,8cm. | TF: 150daN | LC:1000-2000 daN | Double J Hook Ø9.0 mm. |
No for Lifting | 100% Polyester | Elongation of webbing (max): 7%
Cinta: 3,7 (+0,3)m. x 3,8cm. | TF: 150daN | LC:1000-2000 daN | Gancho J Doble Ø9.0 mm. |
No para elevación | 100% Poliéster | Elongación de cinta (máx): 7%
EN12195-2

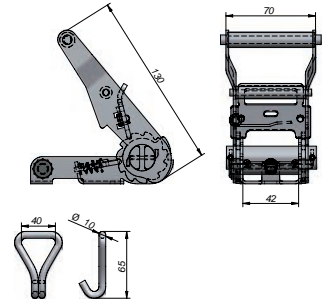

Homologated Tension Strap 5.000 Kg.
Spanngurt 5.000 Kg. Annerkant
Zuncho 5.000 Kg. Homologado

Ref	Kg	Mat	Sup/Finish Acabado	Lot
2301027	2.75	GRP	Zn	1

Web: 8,5 (+0,5)m. x 5cm. | TF: 250daN | LC:2500-5000 daN | Double J Hook Ø12.2 mm. |
No for Lifting | 100% Polyester | Elongation of webbing (max): 7%
Cinta: 8,5 (+0,5)m. x 5cm. | TF: 250daN | LC:2500-5000 daN | Gancho J Doble Ø12.2 mm. |
No para elevación | 100% Poliéster | Elongación de cinta (máx): 7%
EN12195-2

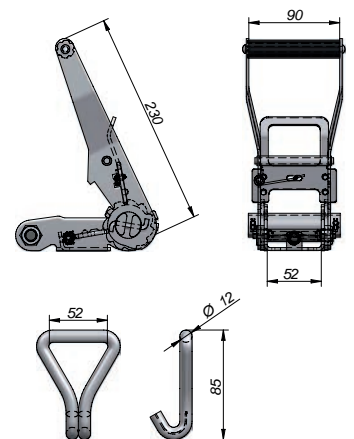

Homologated Tension Strap "Ergo" 5.000 Kg Spanngurt "Ergo" 5.000 Kg Annerkant Zuncho "Ergo" 5.000 Kg. Homologado

Ref	Kg	Mat	Sup/Finish Acabado	Article	Lot
2301030	2.75	GRP	Zn	web: 8,5 (+0,5)m. x 5cm. cinta: 8,5 (+0,5)m. x 5cm.	1
2301032	3.3	GRP	Zn	web: 11,5 (+0,5)m. x 5cm. cinta: 11,5 (+0,5)m. x 5cm.	1

TF: 500daN | LC:2500-5000 daN | Double J Hook Ø11.6 mm. | No for Lifting | 100% Polyester | Elongation of webbing (max): 7%
TF: 500daN | LC:2500-5000 daN | Gancho J Doble Ø11.6 mm. | No para elevación | 100% Poliéster | Elongación de cinta (máx): 7%
EN12195-2

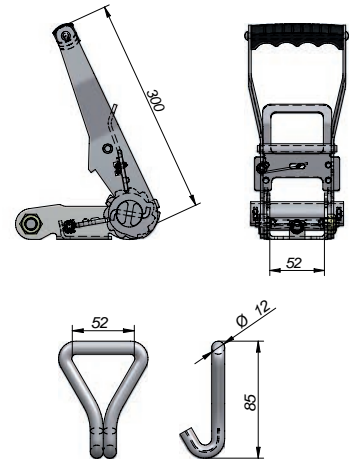

Homologated Tension Strap 4.000 Kg. Spanngurt 4.000 Kg. Annerkant Zuncho 4.000 Kg. Homologado

Ref	Kg	Mat	Sup/Finish Acabado	Lot
2301034	2.27	GRP	Zn	1

Web: 8,5 (+0,5)m. x 5cm. | TF: 200daN | LC:2000-4000 daN | Double J Hook Ø11.6 mm. | No for Lifting | 100% Polyester | Elongation of webbing (max): 7%
Cinta: 8,5 (+0,5)m. x 5cm. | TF: 200daN | LC:2000-4000 daN | Gancho J Doble Ø11.6 mm. | No para elevación | 100% Poliéster | Elongación de cinta (máx): 7%
EN12195-2

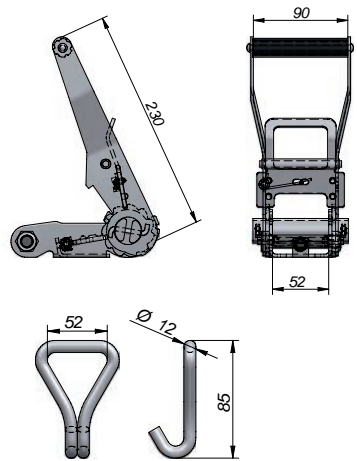

Homologated Tension Strap 4.000 Kg. with open hook Spanngurt 4.000 Kg. mit offenem Drahtaken Annerkant Zuncho 4.000 Kg. c/Gancho abierto Homologado

Ref	Kg	Mat	Sup/Finish Acabado	Lot
2301036	2.22	GRP	Zn	1

Web: 8,5 (+0,5)m. x 5cm. | TF: 200daN | LC:2000-4000 daN | Open J Hook Ø11.6 mm. | No for Lifting | 100% Polyester | Elongation of webbing (max): 7%
Cinta: 8,5 (+0,5)m. x 5cm. | TF: 200daN | LC:2000-4000 daN | Gancho J Abierto Ø11.6 mm. | No para elevación | 100% Poliéster | Elongación de cinta (máx): 7%
EN12195-2

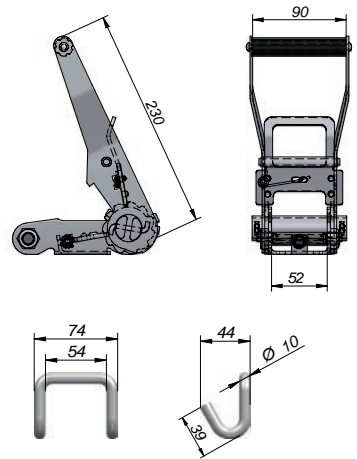

Homologated Tension Strap 2.000 Kg. with COMBI hook Spanngurt 2.000 Kg. mit COMBI-Endbeschlag Annerkant Zuncho 2.000 Kg. c/Gancho COMBI Homologado

Ref	Kg	Mat	Sup/Finish Acabado	Article	Lot
2301064	1.1	GRP	Zn	web: 6 (+0,5)m. x 5cm. cinta: 6 (+0,5)m. x 5cm.	1
2301065	1	GRP	Zn	web: 3,5 (+0,5)m. x 5cm. cinta: 3,5 (+0,5)m. x 5cm.	1

TF: 150daN | LC:1000-2000 daN | COMBI Hook | No for Lifting! | 100% Polyester | Elongation of webbing (max): 7%
TF: 150daN | LC:1000-2000 daN | Gancho COMBI | No para elevación | 100% Poliéster | Elongación de cinta (máx): 7%
EN12195-2

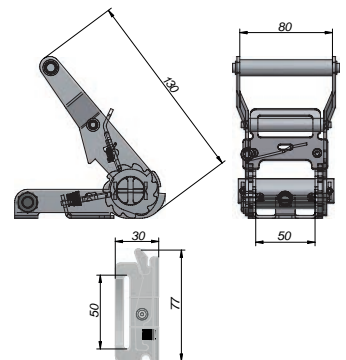



LASHING STRAPS / SPANNURTE / AMARRES DE CARGA

LOADING FASTENING SYSTEMS / LADUNGSSICHERUNG / SISTEMAS DE SUJECCIÓN DE CARGA

Tension Strap Transport of Vehicles 5.000 Kg. with cover
Spanngurt Fahrzeugtransport 5.000 Kg. mit Schutz
Zuncho Transporte Vehículos 5.000 Kg. c/Funda

Ref	Kg	Mat	Sup/Finish Acabado	Lot
2301072	2.8	GRP	Zn	1

Web: 2,5m. x 5cm. | TF: 250daN | LC:2500-5000 daN | Double J Hook Ø12.2 mm. |
No for Lifting | 100% Polyester | Elongation of webbing (max): 7%
Cinta: 2,5m. x 5cm. | TF: 250daN | LC:2500-5000 daN | Gancho J Doble Ø12.2 mm. |
No para elevación | 100% Poliéster | Elongación de cinta (máx): 7%
EN12195-2

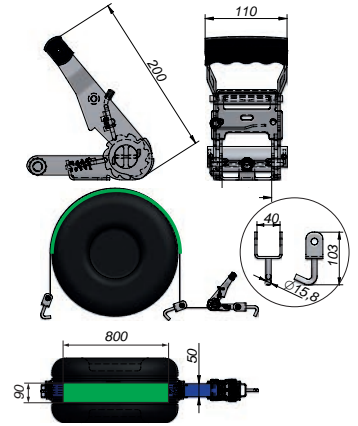

Tensioning Ratchet LC 25kN
Spannratsche LC 25kN
Carraca Tensora LC 25kN

Ref	Kg	Mat	Sup/Finish Acabado	Pack
2301028	17.76	STEEL	Zn	20

LC:2500 daN



Tension Strap (8,5mx5cm) 5.000 Kg w/hook
Spanngurt (8,5mx5cm) 5.000 Kg mit Haken
Cinta Eslinga (8,5mx5cm) 5.000 Kg. c/gancho cerrado

Ref	Kg	Mat	Sup/Finish Acabado	Lot
2301090	1.1	GRP	Zn	1

Closed Hook
Gancho Cerrado

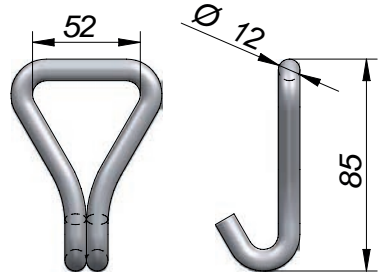

Tension Strap (0,49mx5cm.) with COMBI Hook
Spanngurt (0,49mx5cm) COMBI Haken
Cinta Eslinga (0,49mx5cm) c/gancho COMBI

Ref	Kg	Mat	Sup/Finish Acabado	Lot
2301091	0.29	GRP	Zn	1

COMBI Hook
Gancho COMBI

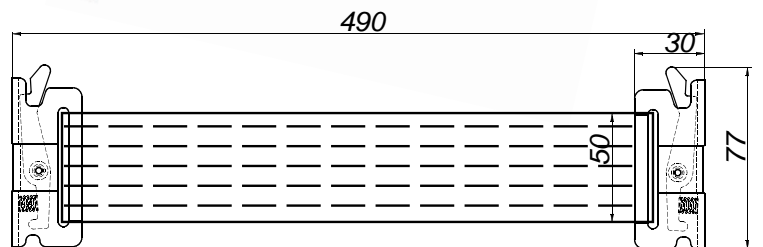
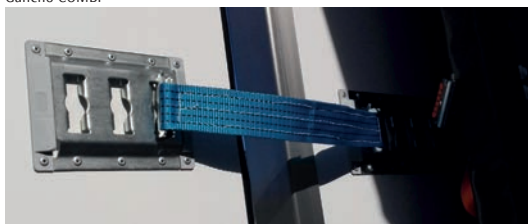



Anti-slip Carpet
 Antirutsch-Matte
 Alfombra antideslizante

Ref	Kg	Mat	A	B	Thickn. Espesor	Lot
2301082	8.75		5000	250	8	1
2301083	3.5		5000	100	8	1
2301086	3		5000	250	3	1

Made of highly pressed rubber granule(recycle material) |
 High sliding friction coefficient >0.6. | Temperature range -40/+115°C
 Material: Gránulos de caucho fuertemente presionado (reciclable) |
 Coeficiente fricción de deslizamiento > 0.6 | Rango de Temperatura -40°C / + 115°C

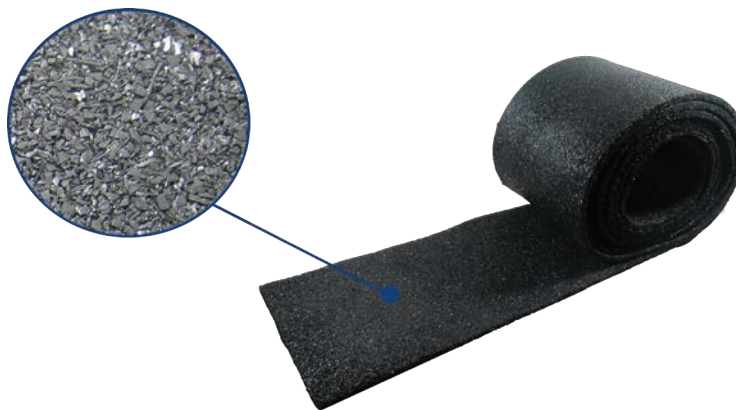

LOADING FASTENING SYSTEMS / LADUNGSSICHERUNG / SISTEMAS DE SUJECCIÓN DE CARGA



ADAICO Label (according to Norm EN12195-2)

Etiqueta ADAICO (según Norma EN12195-2)

According to the EN 12195-2 Norm, tension straps must be provided with a label with specifications shown on it. This label must be attached to both the ratchet parts. For polyester tension straps, the label must be blue.

Según la norma EN 12195-2, las cintas de amarre deben ir provistas de una etiqueta con las especificaciones del fabricante. Debe estar cosida en ambas partes del dispositivo tensor. Para cintas tensoras de poliéster, la etiqueta debe ser azul.

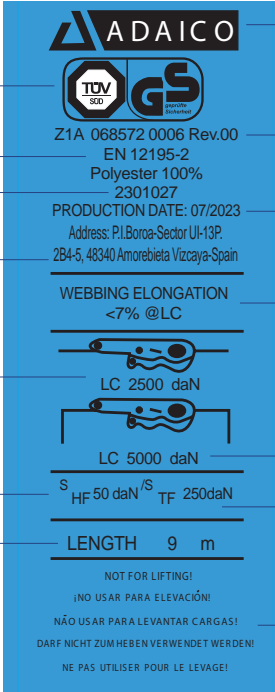

The TÜV SÜD certification Mark
La marca de certificación TÜV SÜD

Manufactured according to Norm EN12195-2
Fabricado según Norma EN12195-2

ADAICO Reference
Referencia ADAICO

Manufacturer or distributor address
Dirección del fabricante o distribuidor

Lashing capacity for tension in straight line (value in daN*)
Capacidad de carga tensión directa (valor en daN)*

SHF: Standard Hand Force (value in daN*)
SHF: Fuerza manual normalizada (valor en daN)*

Total length of web, including all parts
Longitud total de la cinta, incluida todas las partes

* 1 Kg. = 9,81 N
10 N = 1 daN
=> 1 daN ca 1 k

Name of manufacturer or distributor
Nombre del fabricante o distribuidor

Nº homologation ADAICO
Nº de homologación ADAICO

Fecha de fabricación
Manufacturing date

Stretching of the lashing strap
Alargamiento de la cinta

Lashing Capacity by strapping (value in daN*)
Capacidad de carga tensión doble (valor en daN)*

STF: Standard Tension Force (value in daN*)
STF: Fuerza de tensión normalizada (valor en daN)*

Warning: may not be used for lifting!
Aviso: No puede ser utilizado para elevar cargas

ADAICO LASHING STRAPS

ESLINGAS ADAICO

Ref.	LC1	LC2	SHF	STF	L	EN12195-2
2301025	1.500 daN	3.000 daN	50 daN	150 daN	7,3m.	✓
2301026	1.000 daN	2.000 daN	50 daN	150 daN	4m.	✓
2301027	2.500 daN	5.000 daN	50 daN	250 daN	9m.	✓
2301030	2.500 daN	5.000 daN	50 daN	500 daN	9m.	✓
2301032	2.500 daN	5.000 daN	50 daN	500 daN	12m.	✓
2301034	2.000 daN	4.000 daN	50 daN	250 daN	9m.	✓
2301036	2.000 daN	4.000 daN	50 daN	250 daN	9m.	✓
2301064	1.000 daN	2.000 daN	50 daN	150 daN	6,5m.	✓
2301065	1.000 daN	2.000 daN	50 daN	150 daN	4m.	✓
2301072	2.500 daN	5.000 daN	50 daN	250 daN	2,5m.	✓
2301090	2.500 daN	5.000 daN	50 daN	250 daN	8,5m.	✓

PERSONALIZATION WITH LOGO

PERSONALIZACION CON LOGO



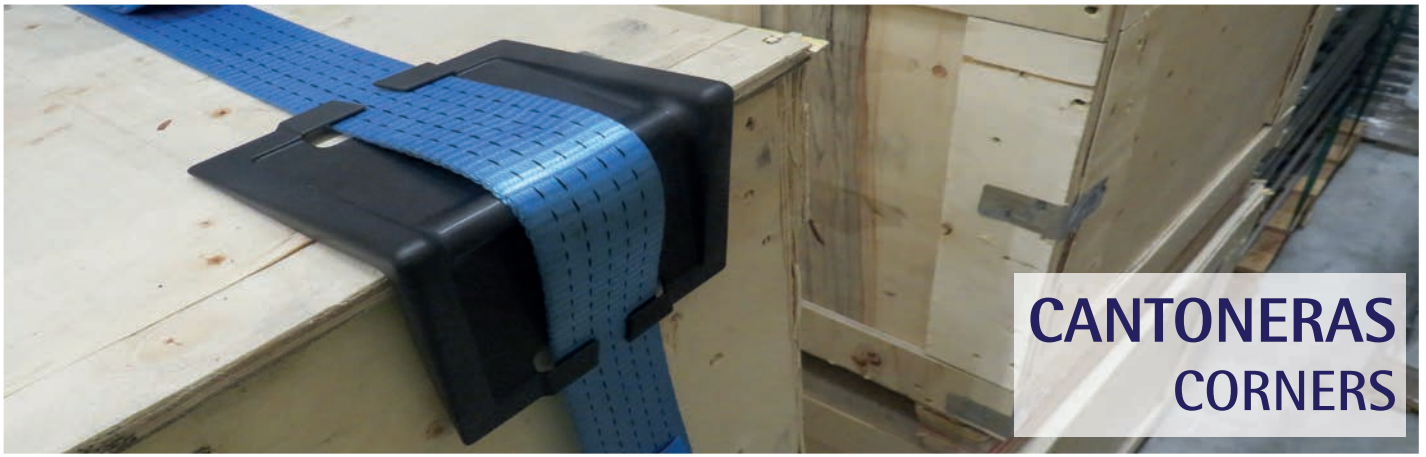

**CANTONERAS
CORNERS**

Corner Protector 90° max: 60 mm.
Kantenschutzwinkel für Spanngurte 90° max: 60 mm.
Cantonera Pallet Plástico 90° máx: 60 mm.

Ref	Kg	Mat	Col	Thickn. Espesor	Lot
2301096	0.07	PP	●	5.5	20

Strap maximum width: 60 mm. | strap slots secure your strap in place | Reinforced structure | Antislip grip
Ancho máx correa: 60 mm. | Ranuras impiden salida de correa | Estructura reforzada | Agarre antideslizante

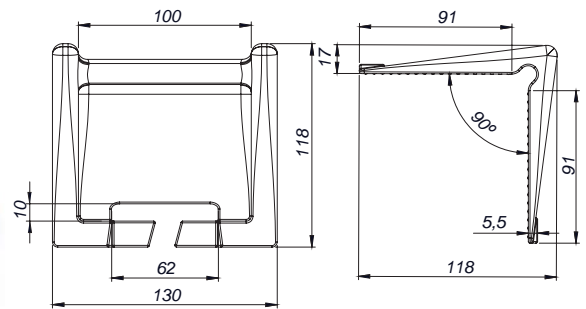

Corner Protector 90° max: 80 mm.
Kantenschutzwinkel für Spanngurte 90° max: 80 mm.
Cantonera Pallet Plástico 90° máx: 80 mm.

Ref	Kg	Mat	Col	Thickn. Espesor	Lot
2301097	0.07	PP	●	5.5	20

Strap maximum width: 80 mm. | strap slots secure your strap in place | Reinforced structure | Antislip grip
Ancho máx correa: 80 mm. | Ranuras impiden salida de correa | Estructura reforzada | Agarre antideslizante

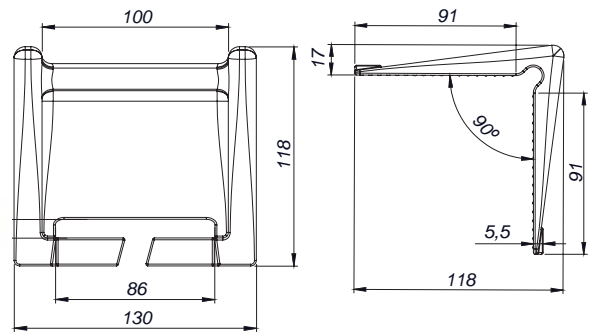

Corner Protector 90-180° max: 60 mm.
Kantenschutzwinkel für Spanngurte 90-180° max: 60 mm.
Cantonera Pallet Plástico 90-180° máx: 60 mm.

Ref	Kg	Mat	Col	Thickn. Espesor	Lot
2301095	0.31	PP	●	4	10

Strap maximum width: 60 mm. | strap slots secure your strap in place | Robust | 2 pressure points to ensure optimum tension distribution
Ancho máx correa: 60 mm. | Ranuras impiden salida de correa | Robustez | 2 puntos de presión (garantizan distribución óptima de la fuerza de tracción)

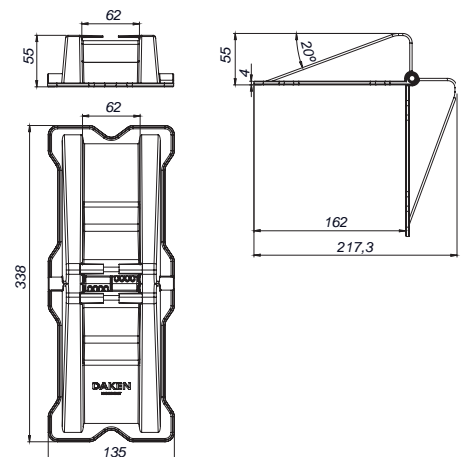



LASHING STRAPS / SPANNURTE / AMARRRES DE CARGA

LOADING FASTENING SYSTEMS / LADUNGSSICHERUNG / SISTEMAS DE SUJECCIÓN DE CARGA

Pallet Corner Protector 90x90x130
Kantenschutzwinkel 90x90x130
Cantenera Pallet 90x90x130

Ref	Kg	Mat	Col	Thickn. Espesor	Lot
2301093	0.08	PE	●	2.5	1

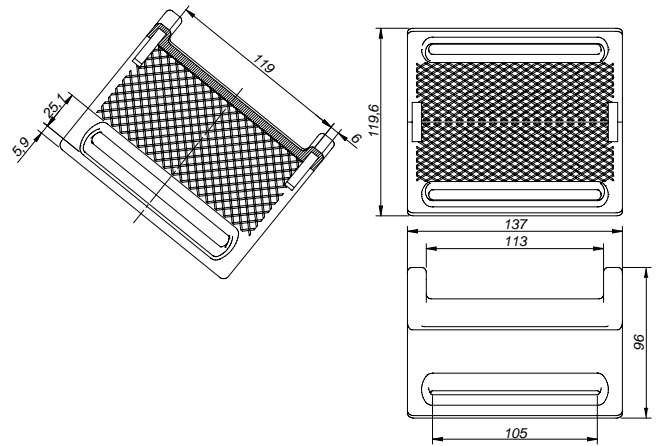

Corner Protector for Paper Coil
Kantenschutzwinkel für Papiercoil
Cantenera para Bobinas papel

Ref	Kg	Mat	Col	Lot
2301094	0.23	PE	●	1

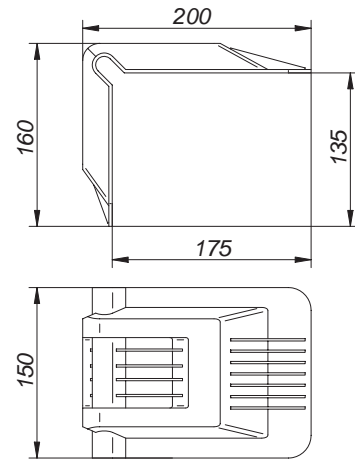

Black Plastic PE-HD Corner Protector 185x145
Kantenschutzwinkel Kunststoff PE-HD Schwarz 185x145
Cantenera Plástico PE_HD Negra 185x145

Ref	Kg	Mat	Col	A	Lot
2301076	4	PE	●	2400	1
2301078	2	PE	●	1200	1



Yellow Plastic Corner Protector 800x193x193
Kantenschutzwinkel Kunststoff Gelb 800x193x193
Cantenera Plástico Amarilla 800x193x193

Ref	Kg	Mat	Col	Lot
2301098	1.13	PE	●	1

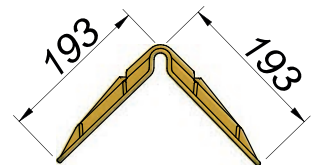
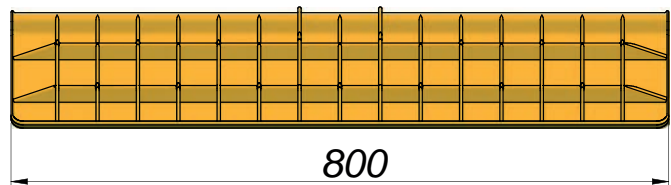
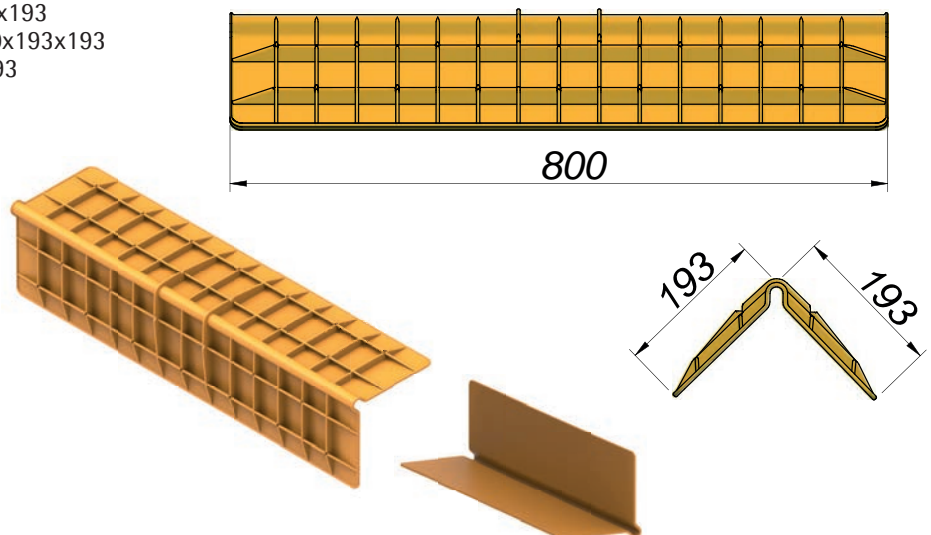



**PERFIL COMBI
COMBI RAIL**

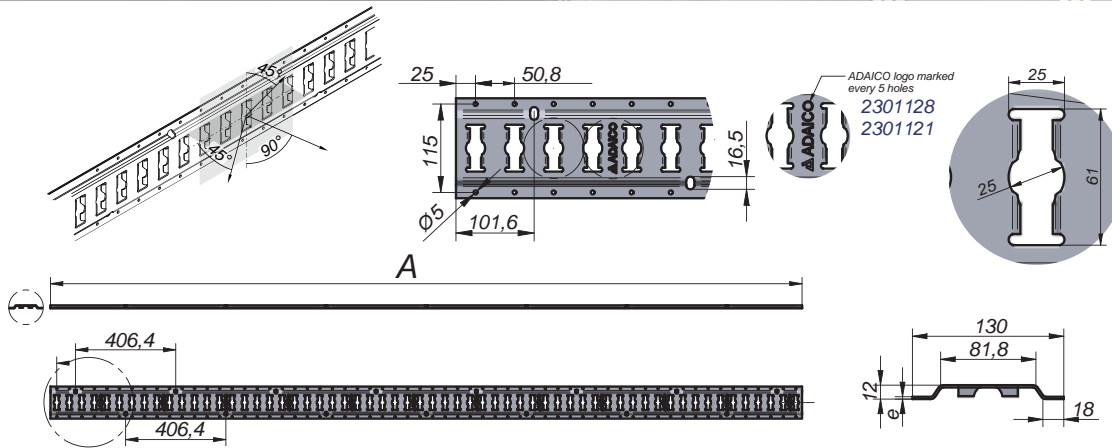

Aplicaciones
Applications



Steel AZM ADAICO COMBI Anchor Track e=2mm.
ADAICO KOMBI-Zurrschiene Stahl AZM e=2mm.
Perfil COMBI ADAICO Acero AZM e=2mm.

Ref	Kg	Mat	Sup/Finish Acabado	Pos	A	Thickn. Espesor	Lot
2301121	5.6	STEEL	AZM		3050	2	1

NEW

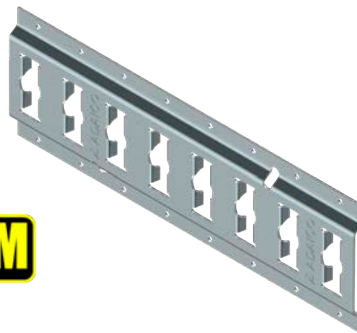

New Coating

Nuevo Recubrimiento **AZM**

- ✓ High resistance against corrosion (1.000h saline fog test)
- ✓ Material: steel with AZM coating **AZM** (aluminum-zinc-magnesium)
- ✓ Price savings against stainless steel
- ✓ Optimal for isothermic vehicles and ideal for environments exposed to chlorides and ammonia
- ✓ Alta resistencia a la corrosión (1.000h. test de niebla salina)
- ✓ Material: acero con recubrimiento **AZM** (aluminio-zinc-magnesio)
- ✓ Ahorro de Precio frente al acero Inox
- ✓ Idóneo para vehículos isoterms y entornos con exposición a cloruros y amoniacos



LOADING FASTENING SYSTEMS / LADUNGSSICHERUNG / SISTEMAS DE SUJECCIÓN DE CARGA



LOADING RAILS / ZURRSCHIENEN / PERFILES DE CARGA

LOADING FASTENING SYSTEMS / LADUNGSSICHERUNG / SISTEMAS DE SUJECCIÓN DE CARGA

Zinc Plated Steel ADAICO COMBI Anchor Track e=2mm.
ADAICO KOMBI-Zurrschiene Verzinkt e=2mm.
Perfil COMBI ADAICO Acero Cincado e=2mm.

Ref	Kg	Mat	Sup/Finish Acabado	Pos	A	Thickn. Espesor	Lot
2301128	5.6	STEEL	Zn		3050	2	1

LC 90° = 941 daN | LC 45° = 568 daN
Capacidad de carga 90° = 941 daN | Capacidad de carga 45° = 568 daN

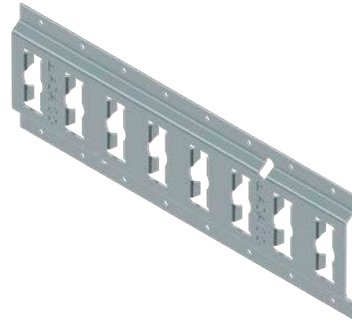

Zinc Plated Steel COMBI Anchor Track e=2,5mm.
ADAICO KOMBI-Zurrschiene Verzinkt e= 2,5mm.
Perfil COMBI Acero Cincado e=2,5mm.

Ref	Kg	Mat	Sup/Finish Acabado	Pos	A	Thickn. Espesor	Lot
2301120	6.8	STEEL	Zn		3050	2.5	1

LC 90° = 971 daN | LC 45° = 616 daN
Capacidad de carga 90° = 971 daN | Capacidad de carga 45° = 616 daN

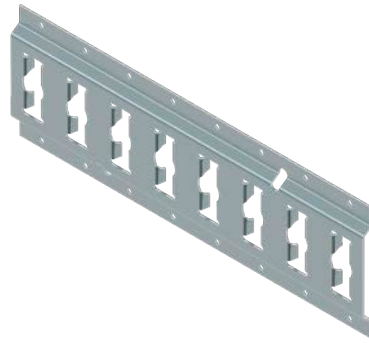

Stainless Steel COMBI Anchor Track e=2mm.
KOMBI-Ankerschiene Edelstahl e=2mm.
Perfil COMBI Acero Inoxidable e=2mm.

Ref	Kg	Mat	Pos	A	Thickn. Espesor	Lot
2301124	7	INOX		3050	2	1

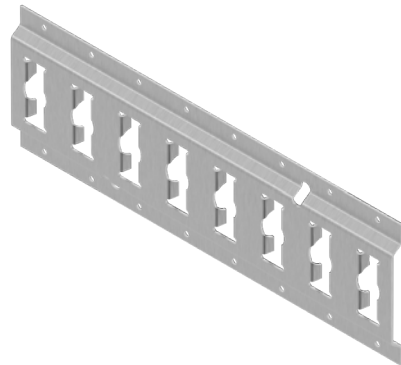

Aluminium COMBI Anchor Track e=3mm.
KOMBI-Ankerschiene Aluminium e=3mm.
Perfil COMBI Aluminio e=3mm.

Ref	Kg	Mat	Pos	A	Thickn. Espesor	Lot
2301125	2.85			3048	3	1

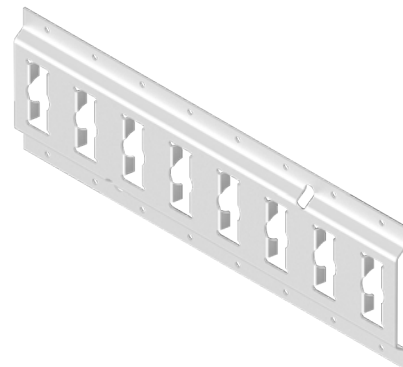

Plastic End Cap for COMBI Anchor Track
Endstück Kunststoff f. KOMBI Zurrschiene
Terminal Plástico Perfil COMBI

Ref	Kg	Mat	Lot	Pack
2301101	0.2		1	20

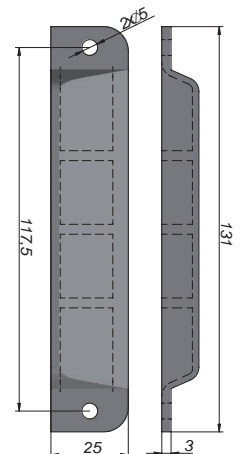



Vértical COMBI Anchor Track
KOMBI-Zurrschiene Vertikal
Perfil COMBI Vertical

Ref	Kg	Mat	Sup/Finish Acabado	Pos	Thickn. Espesor	Lot
2301136	6.4	STEEL	Zn		2.5	1

LC 90° = 1630 daN | LC 45° = 624 daN
Capacidad de carga 90° = 1630 daN | Capacidad de carga 45° = 624 daN

Aplicaciones
Applications

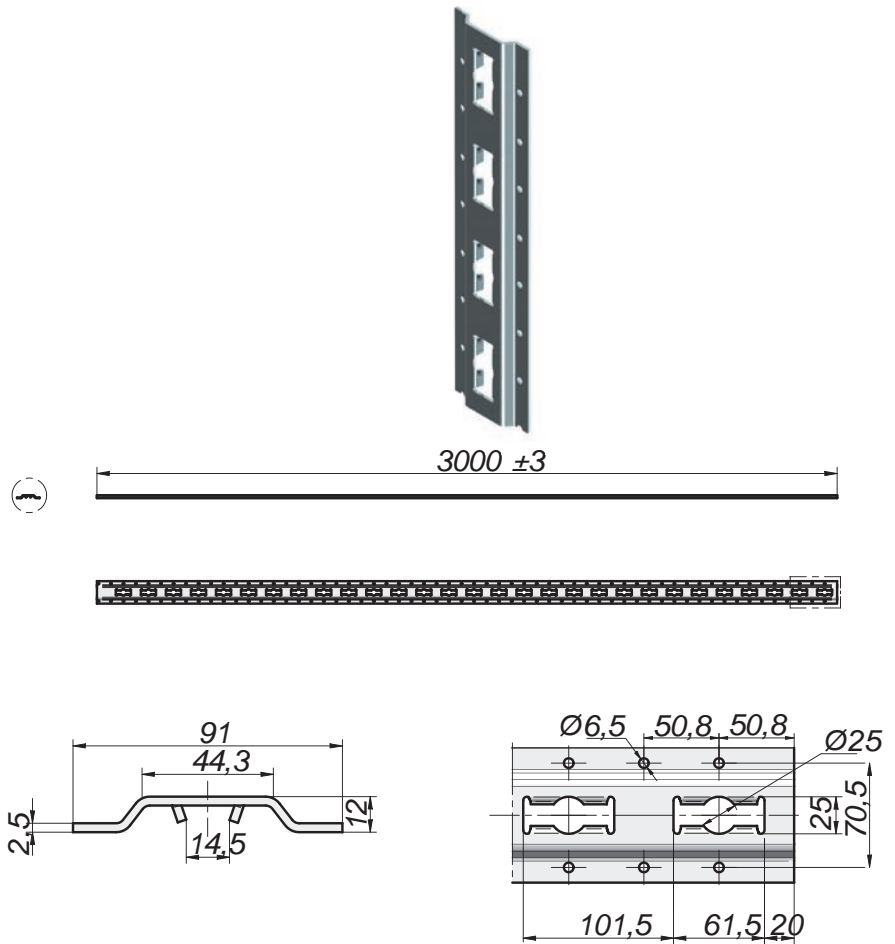
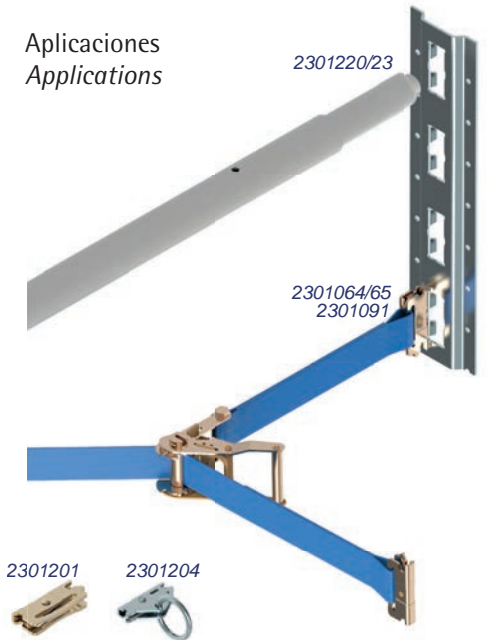

Encastred COMBI Anchor Track 3.048x130 e=2,5 mm.
KOMBI-Zurrschiene Innenliegend 3048x130 e=2,5 mm.
Perfil COMBI Empotrado 3048x130 e=2,5 mm.

Ref	Kg	Mat	Sup/Finish Acabado	Thickn. Espesor	Lot
2301110	6.4	STEEL	Zn	2.5	1

Aplicaciones
Applications

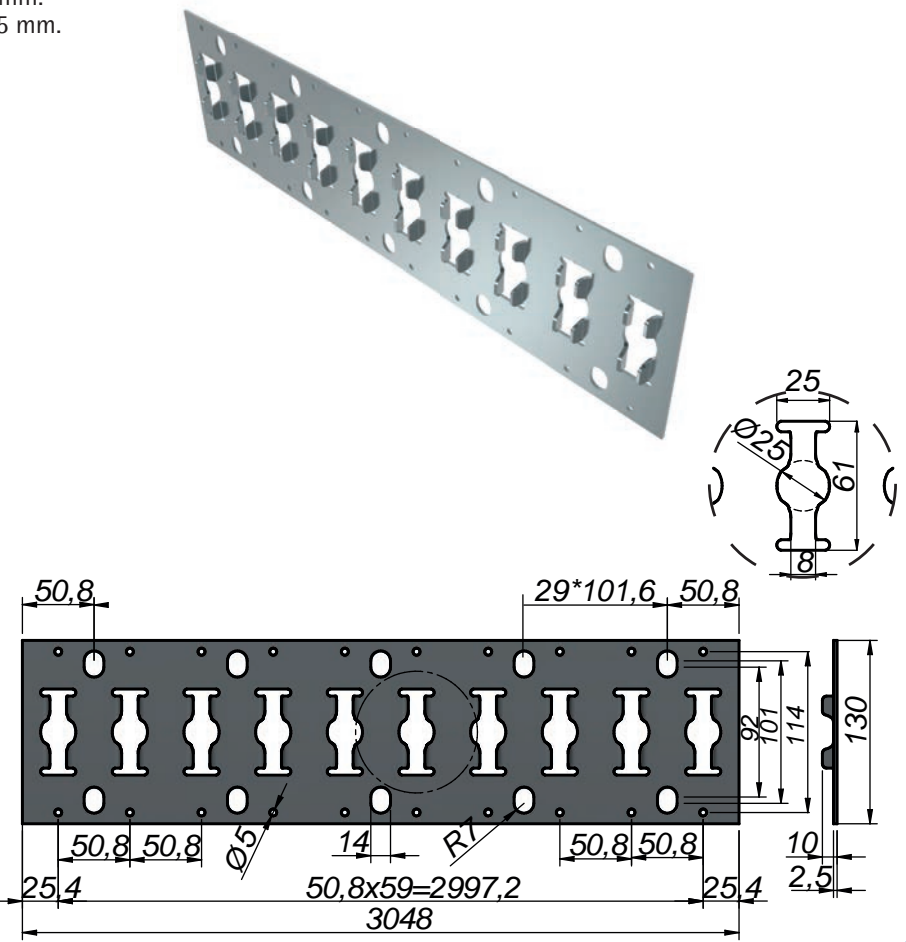
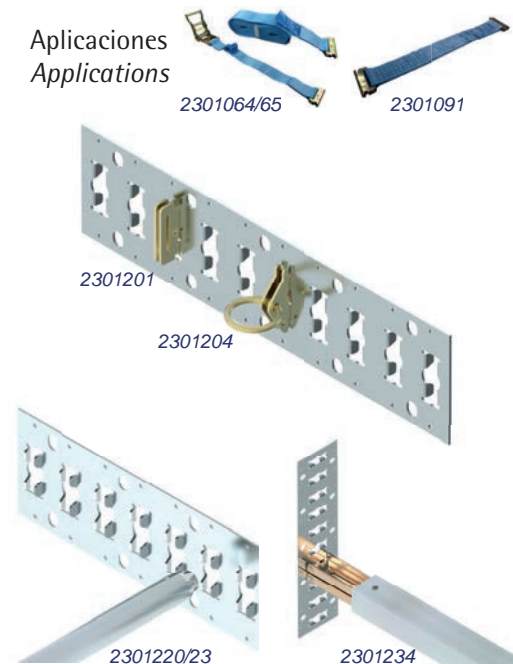

LOADING FASTENING SYSTEMS / LADUNGSSICHERUNG / SISTEMAS DE SUJECIÓN DE CARGA



Lock Cap for COMBI Profile
Endstück für KOMBI-Zurrschiene COMBI
Terminal Cierre para Perfil COMBI

Ref	Kg	Mat	Sup/Finish Acabado	Lot
2301201	0.09	STEEL	Zn	10

Breaking Limit 1227 daN
Capacidad de Rotura 1227 daN

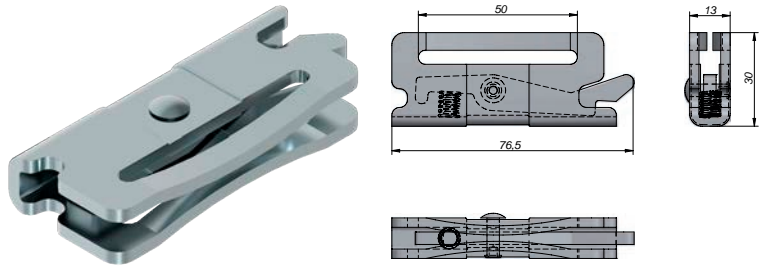

Lock Cap for COMBI Profile with articulated Ring
Endstück für KOMBI-Zurrschiene mit Ring
Terminal Cierre para Perfil COMBI c/Anilla Articulada

Ref	Kg	Mat	Sup/Finish Acabado	Lot
2301204	0.15	STEEL	Zn	4

Breaking Limit 2500 daN | Working Limit 400 daN
Capacidad de Rotura 2500 daN | Capacidad de Trabajo 400 daN

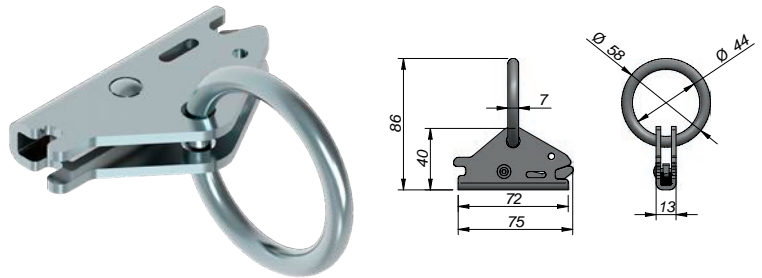

Round Hole Anchor Track 3.000x82x12,5 (2) Horizontal
Rundloch-Zurrschiene 3.000x82x12,5 (2) Horizontal
Perfil Carga 3.000x82x12,5 (2) Horizontal

Ref	Kg	Mat	Sup/Finish Acabado	Thickn. Espesor	Lot
2301150	3.8	STEEL	Zn	2	1

LC 90° = 1170 daN | LC 45° = 586 daN
Capacidad de carga 90° = 1170 daN | Capacidad de carga 45° = 586 daN

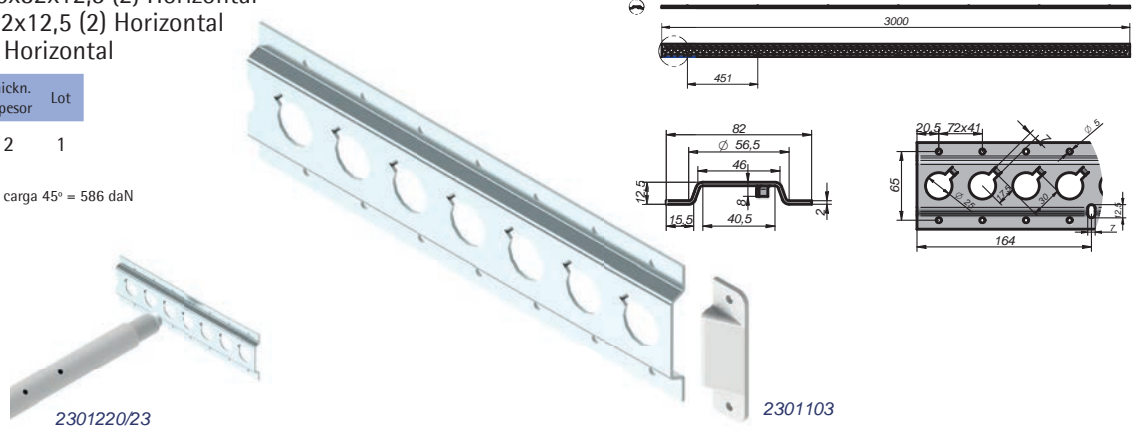

Aplicaciones
Applications



2301103

Plastic End Cap for Round Hole Anchor Track
Endstück Kunststoff f. Zurrschiene
Terminal Perfil Carga Plástico

Ref	Kg	Mat	Lot	Pack
2301103	0.07	Plastic	1	20

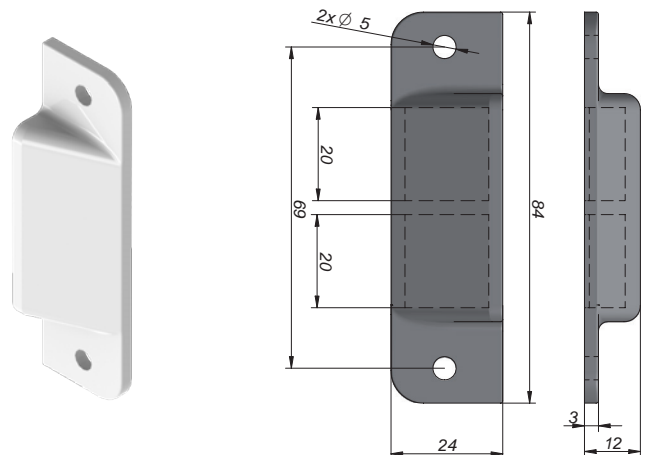

**PERFIL ENMOQUETADO
CARPET PROFILE**

Profile Carpet Covered
Polster-Schiene
Perfil Enmoquetado

Ref	Kg	Mat	Sup/Finish Acabado	A	B	C	Thickn. Espesor	Article	Lot
2301157	2.4			2085	150	25	3		4
2301158	5			4160	150	25	3		4
2301160	6			5000	150	25	3		4
2301162	8	STEEL	Galv	5000	170	30	1		4
2301164	7	STEEL	Galv	5000	170	30	1	with holes c/agujeros	4

Carpeted profile for cargo protection
Perfil enmoquetado para protección de carga

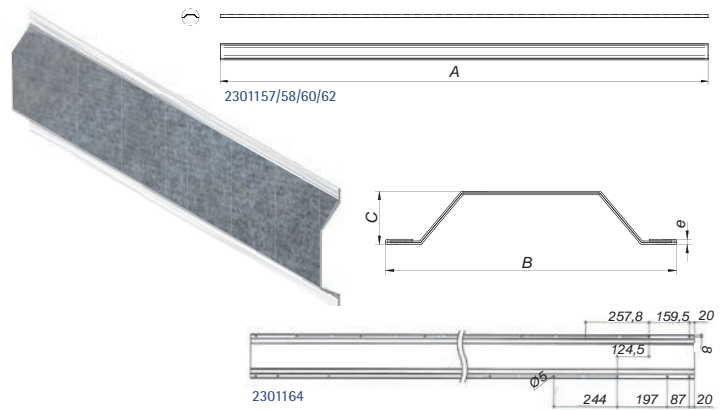

Galvanized Steel Keyhole Anchor Track 3.000x133
Schlüsselloch-Profil Stahl Feuerverzinkt 3.000x133
Perfil Bocallave Horizontal Galvanizado 3.000x133

Ref	Kg	Mat	Sup/Finish Acabado	Pos	Thickn. Espesor	Lot
2301132	5	STEEL	Galv		1.5	1

LC90° = 1081 daN | LC45° = 314 daN
Capacidad de carga 90° = 1081 daN | Capacidad de carga 45° = 314 daN

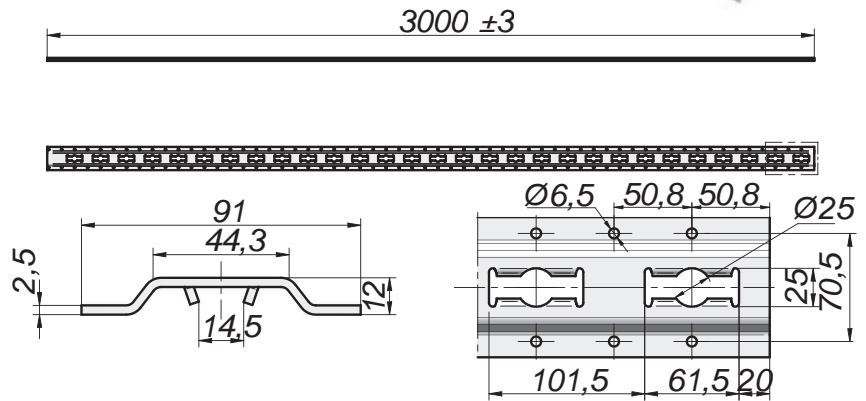

Aplicaciones
Applications



2301242

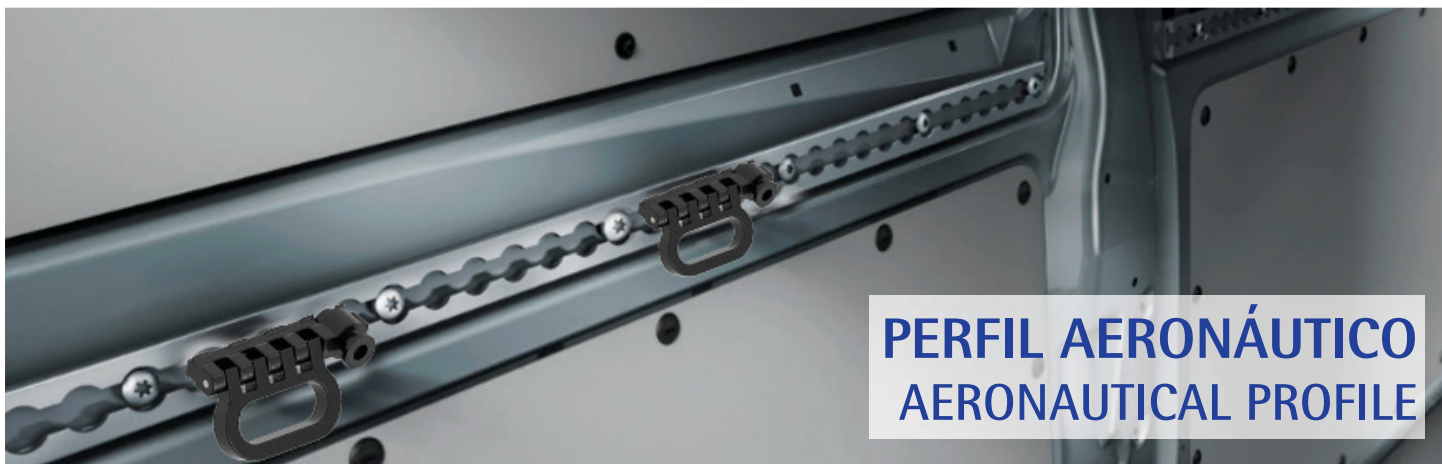

**PERFIL AERONÁUTICO
AERONAUTICAL PROFILE**

Aplicaciones
Applications

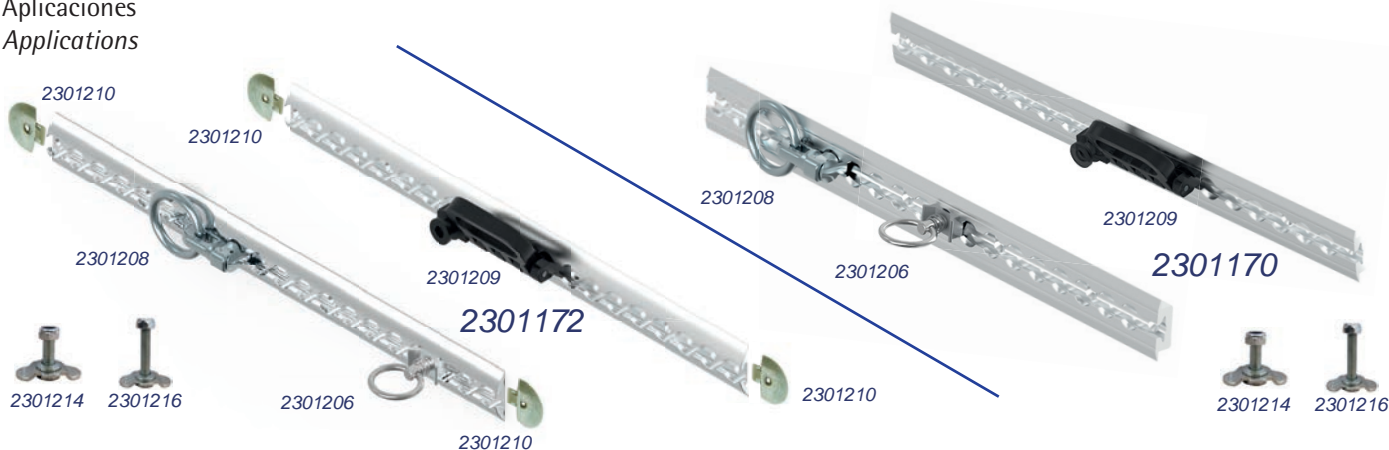

Encastred Airline Profile Anchor Track 2.540x50x15
Airline Schiene Innenliegend 2.540x50x15
Perfil Aeronáutico para Empotrar 2.540x50x15

Ref	Kg	Mat	Lot
2301170	2.87		1

LC90° = 1825 daN | LC45° = 605 daN
Capacidad de carga 90° = 1825 daN | Capacidad de carga 45° = 605 daN

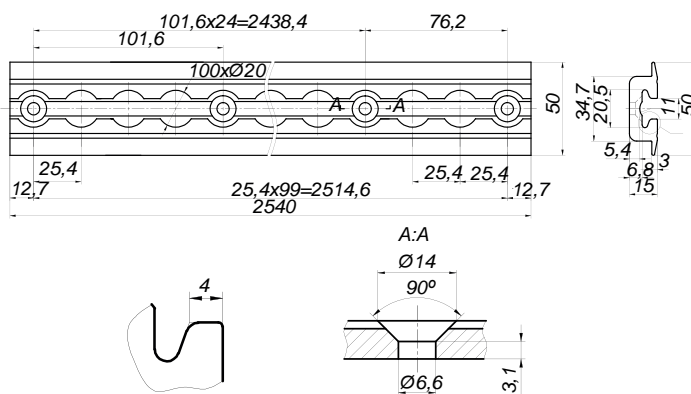

Airline Profile Anchor Track 3.000x50x11,5
Airline Schiene 3.000x50x11,5
Perfil Aeronáutico 3.000x50x11,5

Ref	Kg	Mat	Sup/Finish Acabado	Lot
2301172	2.26		Anod	1

LC 90° = 967 daN | LC 45° = 605 daN
Capacidad de carga 90° = 967 daN | Capacidad de carga 45° = 605 daN

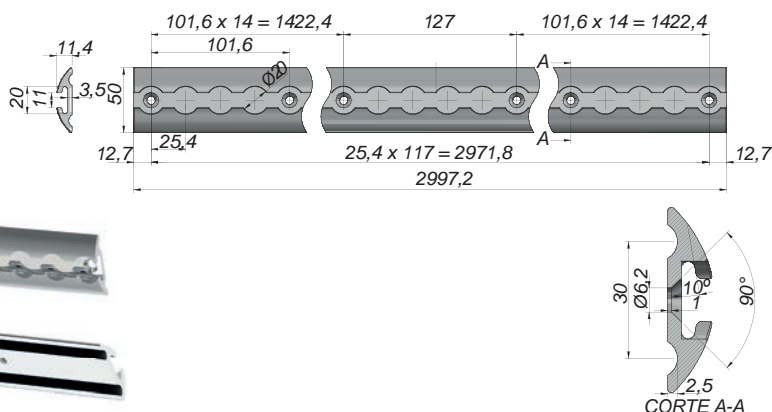

Plastic End Cap for Airline Anchor Track 2301172
 Endstück Kunststoff für 2301172
 Terminal Rail Plástico para 2301172

Ref	Kg	Mat	Lot
2301210	0.01		10

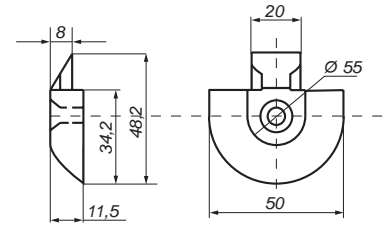

Double Airline Fitting
 Doppel-Endbeschlag mit Ring für Airline Schiene
 Terminal Cierre para Perfil Aeronáutico Doble c/Anilla

Ref	Kg	Mat	Sup/Finish Acabado	Lot
2301208	0.14	STEEL	Zn	4

Breaking Limit 1300 daN | Working Limit 850 daN
 Capacidad de Rotura 1300 daN | Capacidad de Trabajo 850 daN

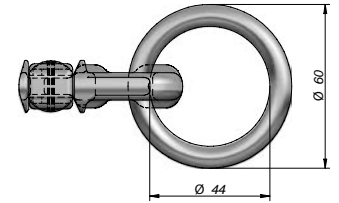
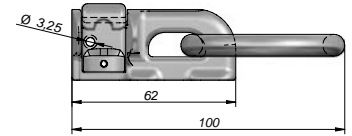

Airline Lashing Point Ø45x10,3 for 2301206
 Basisprofil Ø45x10,3 für 2301206
 Base Aeronáutica Ø45x10,3 para 2301206

Ref	Kg	Mat	Lot
2301205	0.02		4

Breaking Limit 530 daN
 Capacidad de Rotura 530 daN

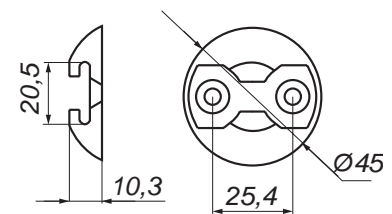

Single Airline Fitting
 Einfach-Endbeschlag mit Ring für Airline Schiene
 Terminal Cierre para Perfil Aeronáutico Simple c/Anilla

Ref	Kg	Mat	Sup/Finish Acabado	Lot
2301206	0.05	STEEL	Zn	10

Material: Aluminum anchor base and metal ring | Breaking Limit 2560 daN | Working Limit 1640 daN
 Material: Base anclaje aluminio | Anillo, resorte y pilar en Acero Cincado | Capacidad de Rotura 2560 daN | Capacidad de Trabajo 1640 daN

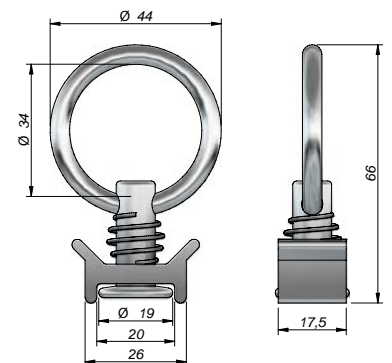



LOADING RAILS / ZURRSCHIENEN / PERFILES DE CARGA

LOADING FASTENING SYSTEMS / LADUNGSSICHERUNG / SISTEMAS DE SUJECCIÓN DE CARGA

Quatro Airline Fitting, Black KTL
Einfach-Endbeschlag für Airline Schiene, KTL Schwarz
Argolla Cierre para Perfil Aeronáutico KTL Negro

Ref	Kg	Mat	Sup/Finish Acabado	Col	Lot
2301209	0.39	Forged	KTL	●	2

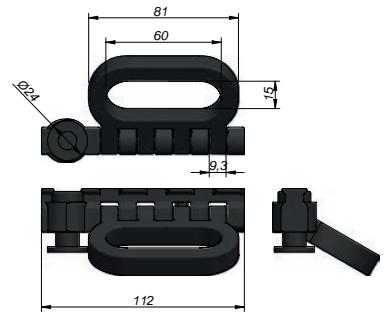

Fixing Set L= 25 mm for Airline Profil
Befestigungssatzf L= 25 mm für Airline Schiene
Set Fijación para Perfil Aeronáutico L=25 mm.

NEW

Ref	Kg	Mat	Lot	Pack
2301214	0.36	STEEL	1	10

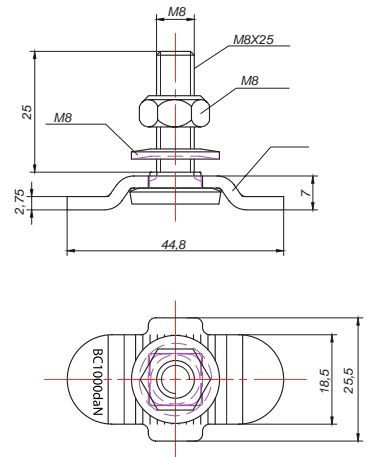

Fixing Set L= 45 mm for Airline Profil
Befestigungssatzf L= 45 mm für Airline Schiene
Set Fijación para Perfil Aeronáutico L=45 mm.

NEW

Ref	Kg	Mat	Lot	Pack
2301216	0.43	STEEL	1	10

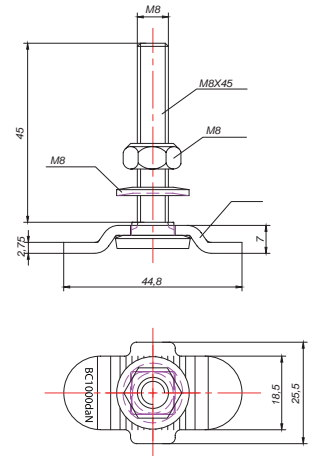

DOUBLE DECK SYSTEM FOR DRY BOX & CONTAINERS

SISTEMA DOBLE PISO PARA CARGA SECA Y CONTENEDOR

LOADING FASTENING SYSTEMS / LADUNGSSICHERUNG / SISTEMAS DE SUJECIÓN DE CARGA

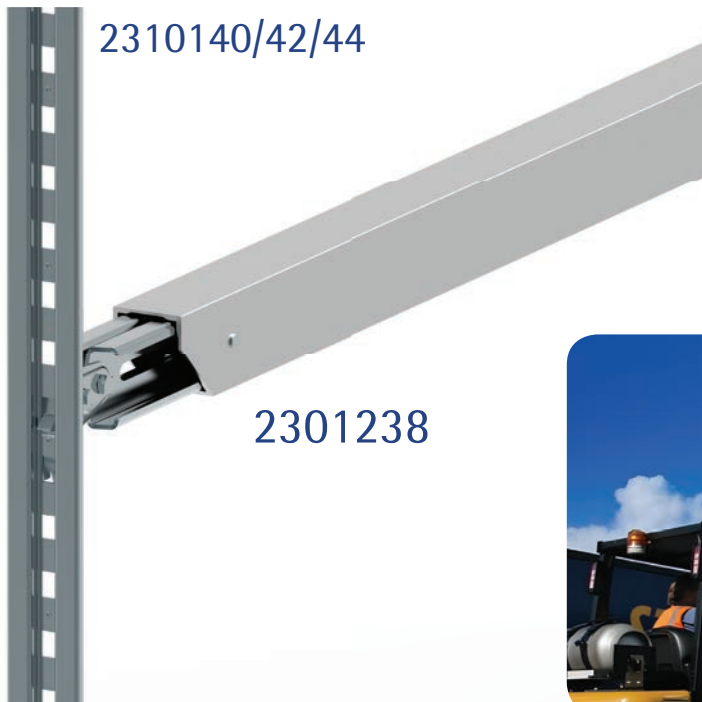

GARMENT TRANSPORT

TRANSPORTE DE ROPA

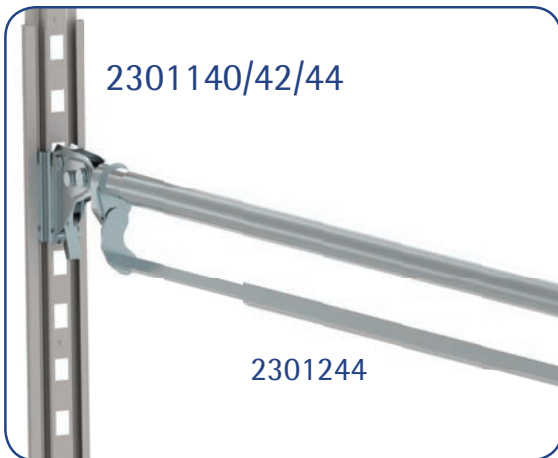

Anchor Track for Garment Rail 2301244
 Rundloch-Zurrschiene für Kleiderstangen Ausziehbar 2301244
 Perfil Galvanizado p/Barra Ropa 2301244

NEW

Ref	Kg	Mat	Sup/Finish Acabado	A	Thickn. Espesor	Lot
2301142	3.38	STEEL	Galv	1524	44987	1
2301140	4.8	STEEL	Galv	2160	44987	1
2301144	5.53	STEEL	Galv	2489	44987	1

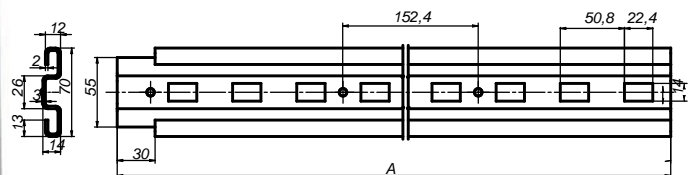



DOUBLE DECK SYSTEM FOR CURTAIN SIDER

SISTEMA DOBLE PISO PARA CAMIÓN DE LONA

LOADING FASTENING SYSTEMS / LADUNGSSICHERUNG / SISTEMAS DE SUJECIÓN DE CARGA



Double Deck Side Profile for Curtainsider
Längsbalken Stahl Verzinkt mit Schüsselloch für LKW-Planen
Perfil Lateral Doble Piso p/Camión Lonas

Ref	Kg	Mat	Sup/Finish Acabado	Col	Pos	A	Strength Fuerza	Article	Lot
2301130	7.5	STEEL	KTL	●		1070	1.250 daN	min: 1.095 - max: 1.110 ±5	1
2301131	13.5	STEEL	KTL	●		2200	1.250 daN	min: 2.225 - max: 2.240 ±5	1

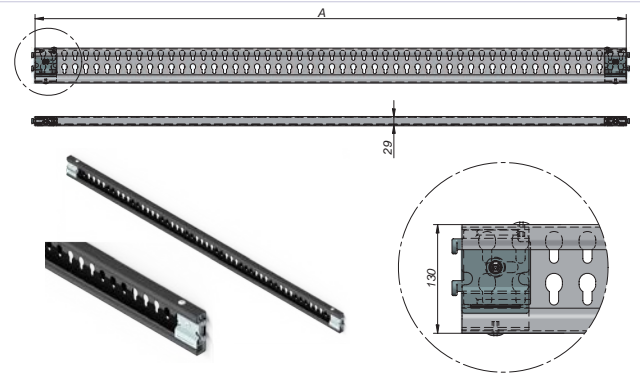

Double Deck Loading Bar for Curtainsider
Ladebalken Doppelstocksystem für LKW-Planen
Barra Carga Aluminio Doble Piso p/Camión Lonas

Ref	Kg	Mat	Strength Fuerza	Lot
2301236	7.5		1.000 daN	1

LC = 1439 daN | min: 2.200 - max: 2.510 ±5
Capacidad de Carga: 1439 daN | min: 2.200 - máx: 2.510 ±5

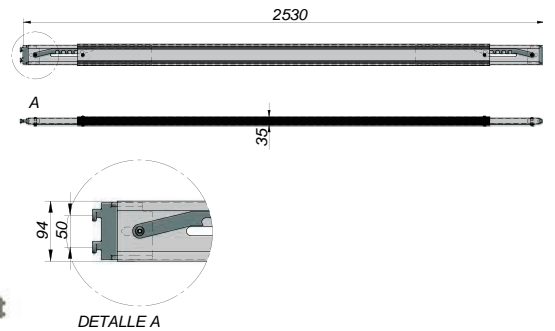

Double Deck Timberholder for Curtainsider
Lattentasche für Doppelstocksystem für LKW-Planen
Cartolilla Doble Piso p/Camión Lonas

Ref	Kg	Mat	Sup/Finish Acabado	Lot
2301212	0.34	STEEL	Zn	1

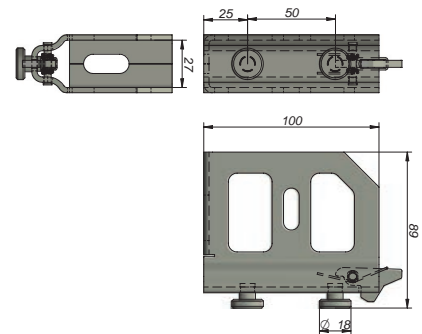

Double Deck U Profile for Curtainsider
U-Profil f. Doppelstocksystem für LKW-Planen
U Doble Piso Bocallave p/Camión Lonas

Ref	Kg	Mat	Pos	Thickn. Espesor	Article	Lot
2301138	2.2	STEEL		3	to weld para soldar	1

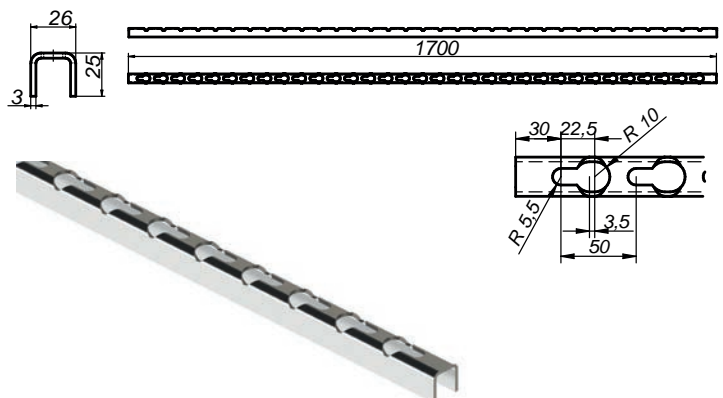



Pin Anchor Track
Stäbchen-Zurrleistenprofil
Perfil Escalera

Ref	Kg	Mat	Lot
2301134	4.3		1

LC90° = 984 daN | LC45° = 857 daN
Capacidad de carga 90° = 984 daN | Capacidad de carga 45° = 857 daN

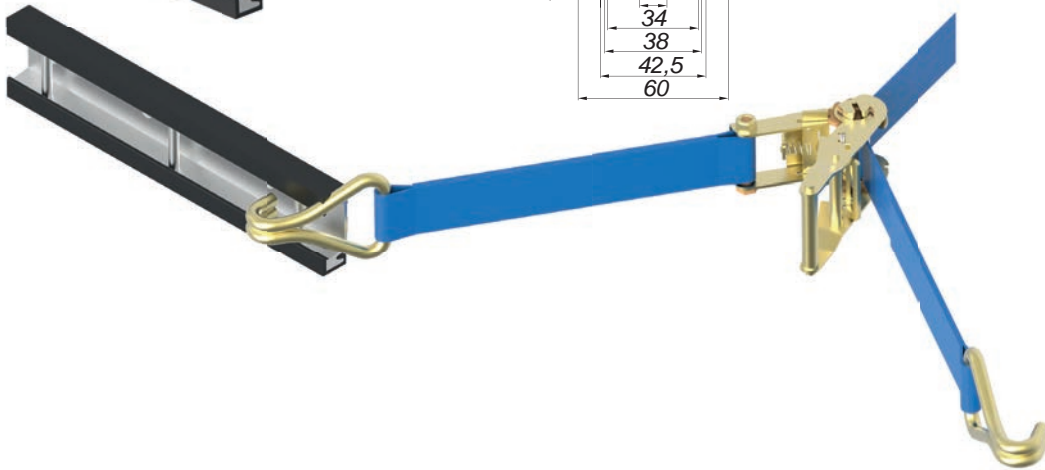
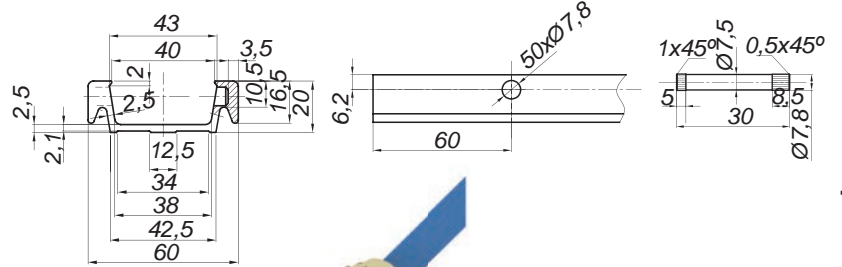
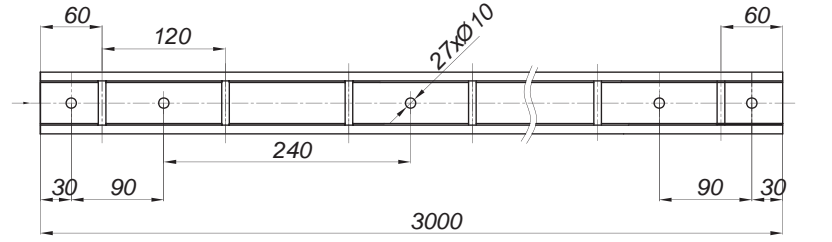

Tool stowage clamp with belt
Utensilienhalter mit Gummiband
Soporte de Herramientas con cincha

Ref	Kg	Mat	Sup/Finish Acabado	Lot
1201320	0.15	STEEL	Zn	10

EPDM shore 20A

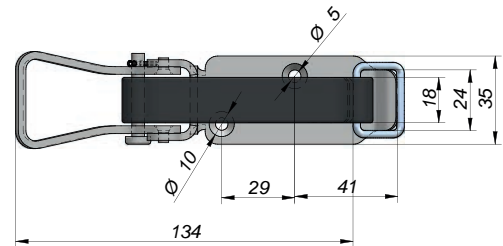
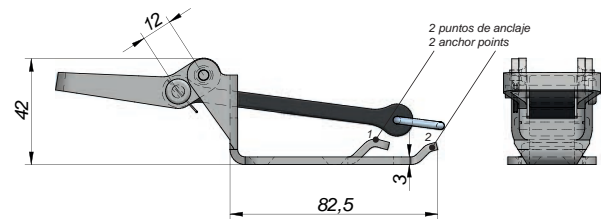
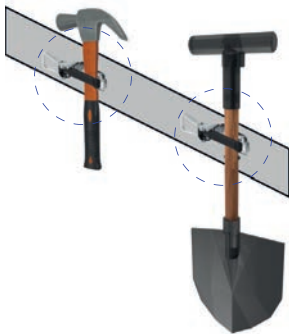

LOADING FASTENING SYSTEMS / LADUNGSSICHERUNG / SISTEMAS DE SUJECIÓN DE CARGA



BARRA DE CARGA DE ACERO STEEL CARGO BAR



Perfil
Profile

COMBI 2301128/20/24/25/21

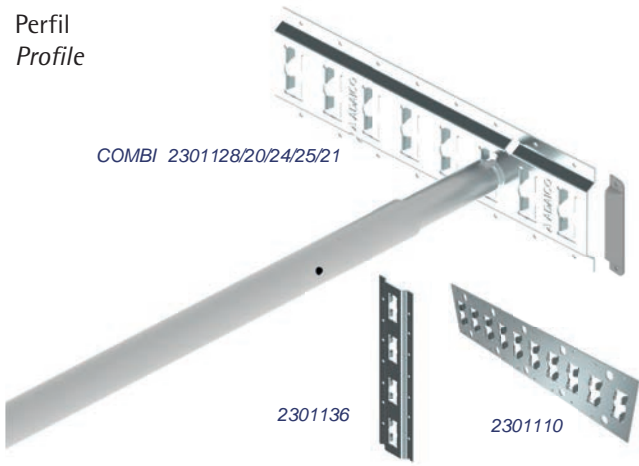

Shoring Bar 2320-2660xØ42 Telescopic w/Push Botton (Ø24)
Teleskop-Rundsperrstange 2320-2660xØ42 m. kon. Kopf (Ø24)
Barra Carga 2320-2660xØ42 Telescópica c/Pulsador (Ø24)

Ref	Kg	Mat	Ø	Lot
2301220	7.5	STEEL	42	1

LC 500 DaN | min: 2320 - max: 2660 (Ø42)
Capacidad de Carga: 500 DaN | min: 2320 - máx: 2660 (Ø42)

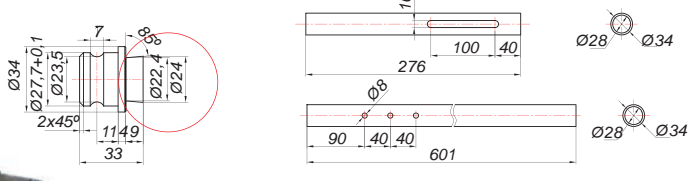
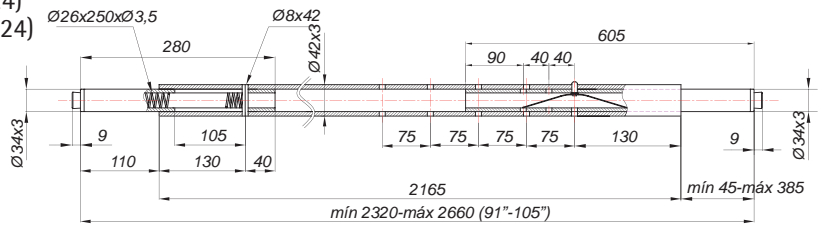

Shoring Bar 2320-2660xØ42 Telescopic w/Push Botton (Ø18)
Teleskop-Rundsperrstange 2320-2660xØ42 m. Kopf (Ø18)
Barra Carga 2320-2660xØ42 Telescópica c/Pulsador (Ø18)

Ref	Kg	Mat	Ø	Lot
2301223	7.5	STEEL	42	1

LC = 517 daN | min: 2320 - max: 2660
Capacidad de Carga: 517 daN | min: 2320 - máx: 2660

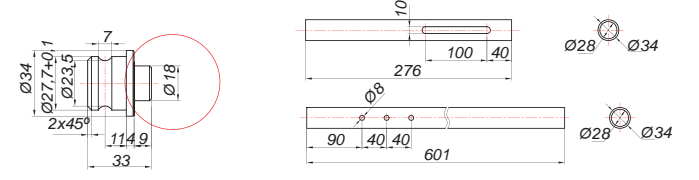
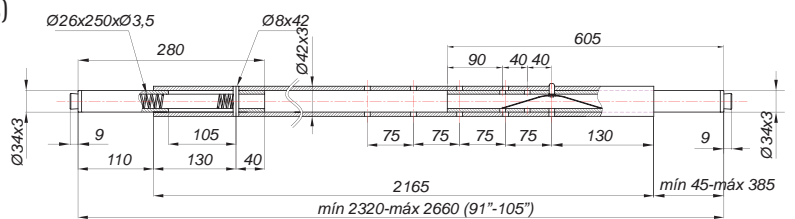



BARRA DE CARGA ALUMINIO
"TACO-TACO"

RATCHET CARGO BAR
IN ALUMINIUM

Telescopic Cargo Bar Ø42 w/Spring
Klemmbalken Verstellbar Ø42 m/Feder
Barra Carga Ø42 c/Muelle 2 topes

Ref	Kg	Mat	Ø	Lot
2301309	4.48		42	1

LC 150 daN | min: 2300 - max: 2960 (Ø42)
Capacidad de Carga: 150 Kg. | min: 2300 - máx: 2960 (Ø42)

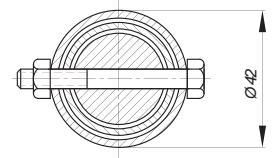
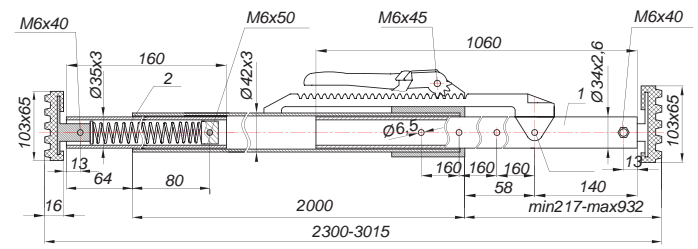

Telescopic Cargo Bar w/Spring - Down Handle
Klemmbalken Verstellbar m/Feder - Griff unten
Barra Carga Taco/Punta - Manilla Inferior

Ref	Kg	Mat	Ø	Lot
2301316	5		42	1

LC 422 daN | Length 3.014 mm. | min: 2294 - max: 3009
Capacidad de Carga (Fuerza a Compresión) 422 daN | Longitud 3.014 mm. | min: 2294 - máx: 3009

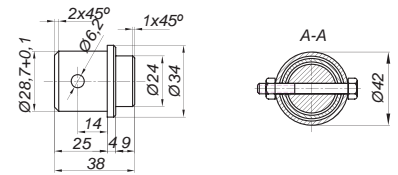
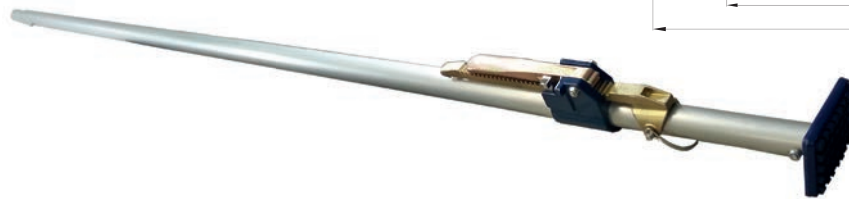
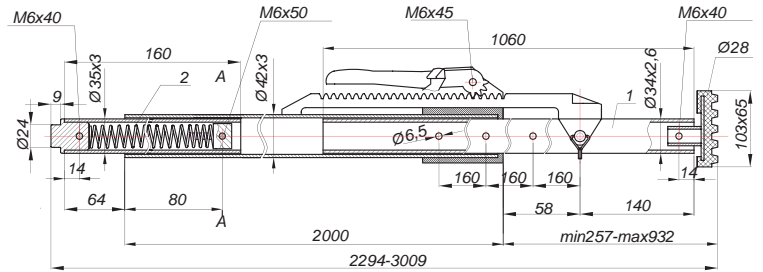

Telescopic Cargo Bar w/Spring - Up Handle
Klemmbalken Verstellbar m/Feder - Griff oben
Barra Carga Taco/Punta - Manilla Superior

Ref	Kg	Mat	Ø	Lot
2301318	5		42	1

LC 663 daN | Length 2.950 mm. | min: 2294 - max: 3009
Capacidad de Carga (Fuerza a Compresión) 663 daN | Longitud 2.950 mm. | min: 2294 - máx: 3009

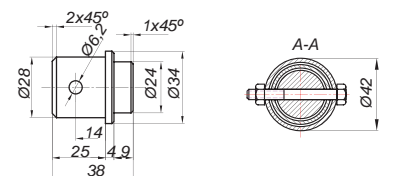
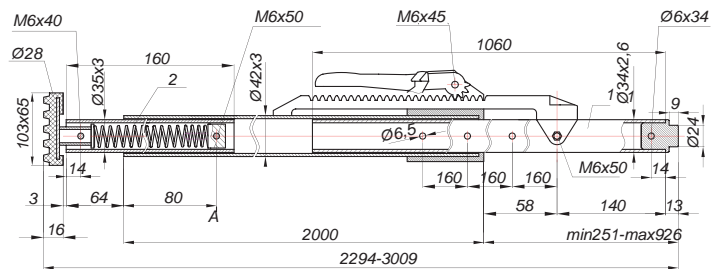



Housing Rack Ø42
 Verstell-Verschluss Ø42
 Cierre Cremallera Ø42

Ref	Kg	Mat	Ø	Lot
2301362	1.15	STEEL	42	1



Rubber Foot for Cargo Bar
 Ersatz-Gummifuß für Klemmbalken
 Tope Barra Telescopica

Ref	Kg	Mat	Lot
2301370	0.35		2

Includes screw and nut
 Incluye tornillo y tuercia

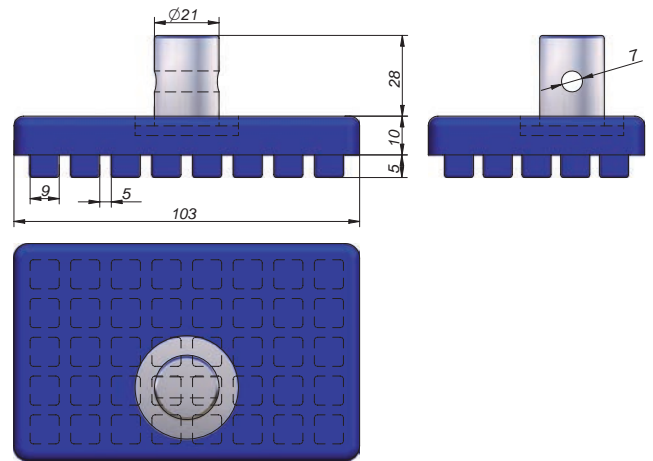

Cargo Hoop Sets f/bar Ø42
 Bügelsatz f/Klemmbalken Ø42
 Kit de Arcos para barra Ø42

Ref	Kg	Mat	Lot
2301365	5.4	STEEL	1

Telescopic bar no included
 Barra no incluida

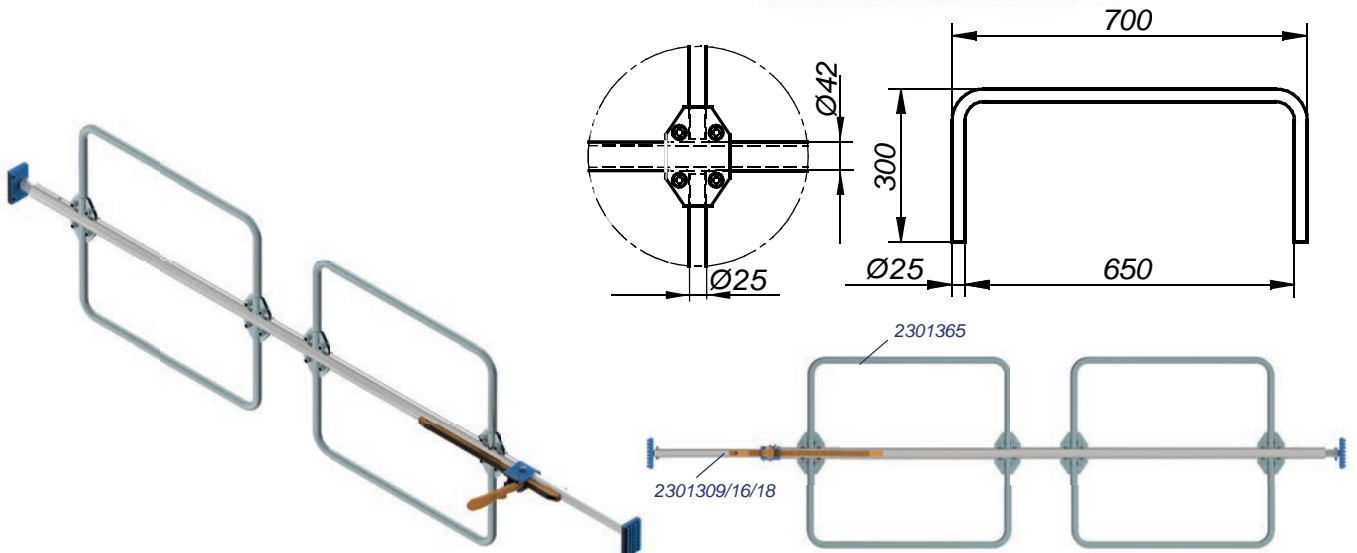
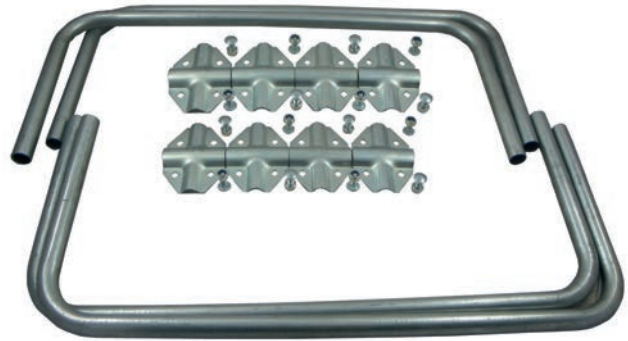

TABIQUE MÓVIL PARTING WALL LOCK



LOADING FASTENING SYSTEMS / LADUNGSSICHERUNG / SISTEMAS DE SUJECCIÓN DE CARGA

Parting Wall Lock 2400-2700 with 2 End Plugs
Zwischenwandverschluss 2400-2700 Aluminium
Barra Carga Extensible 2400-2700 Aluminio 2 Cierres

Ref	Kg	Mat	Thickn. Espesor	Lot
2301228	8.3		2	1

LC 350 DaN | min: 2400 - max: 2700
Capacidad de Carga: 350 DaN | min: 2400 - máx: 2700

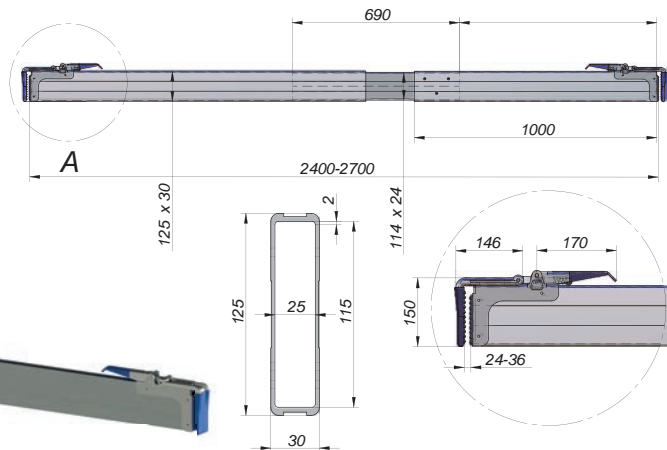

End Plug for Parting Wall Lock
Klemmverschluss m. 3-fach Kunststoffüberzug
Cierre Enganche Barra Carga

Ref	Kg	Mat	Lot
2301217	1.7		2

3 plastic covers
3 cubiertas de plástico

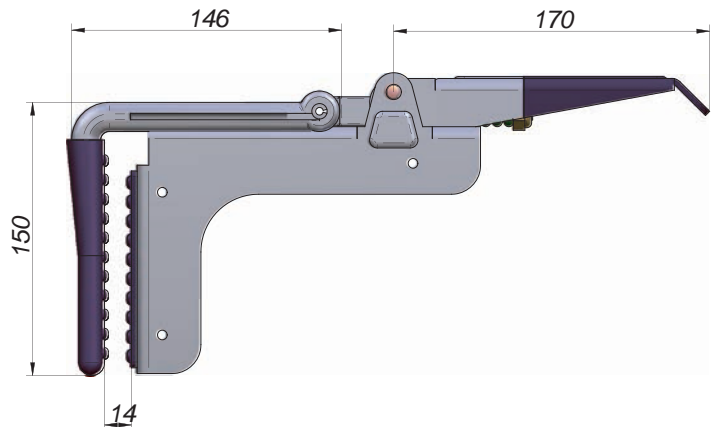

Anti-slip Protector for Lock 2301217
Kunststoffüberzug für Klemmverschluss 2301217
Terminal Plástico para Cierre 2301217

Ref	Kg	Mat	Col	Lot
2301219	0.01			1





**BARRA ROPA
GARMENT RAIL**

Perfil 2301132
Profile



Accesorios
Accessories

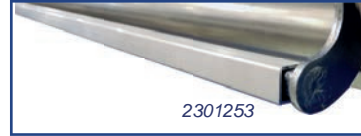
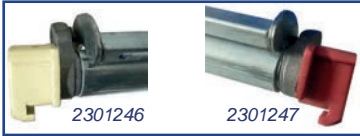

Extensible Garment Rail 2420-2510 (Ø36)
Kleiderstangen Ausziehbar 2420-2510 (Ø36)
Barra para Ropa Extensible 2420-2510 (Ø36)

Ref	Kg	Ø	Thickn. Espesor	Cap.Kg	Lot
2301242	7.4	36	2.5	300	1

LC = 333 daN | min: 2420 - max: 2510
Capacidad de Carga = 333 daN | min: 2420 - máx: 2510

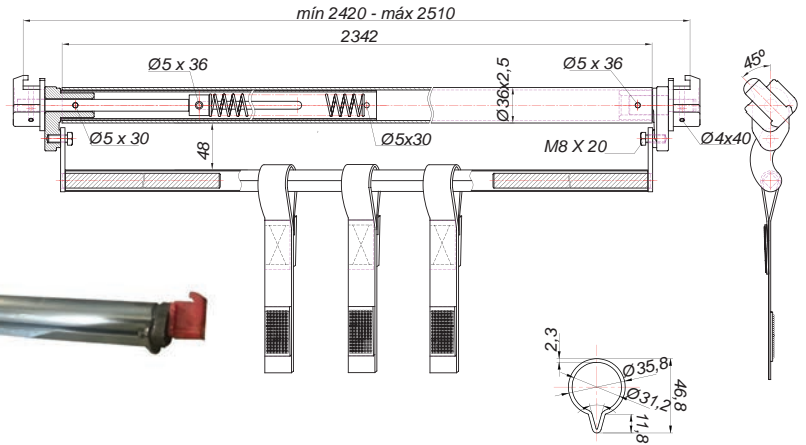

Cap for Garment Bar Extension 2301246
Endbeschlag weiß für Kleiderstange 2301242
Terminal Plástico para barra 2301242

Ref	Kg	Mat	Col	Lot
2301246	0.1			10
2301247	0.1			10

2301246

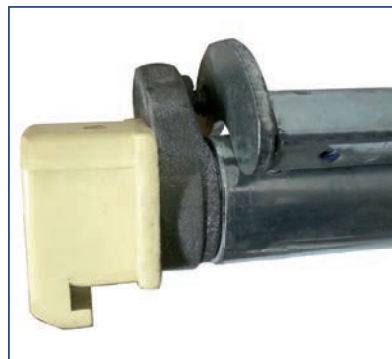

2301247

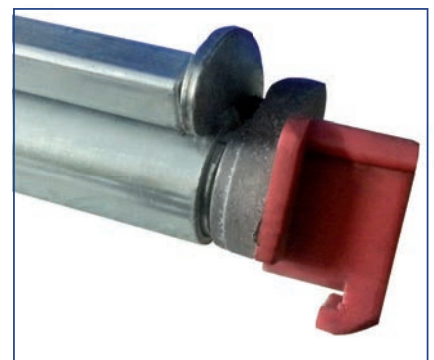

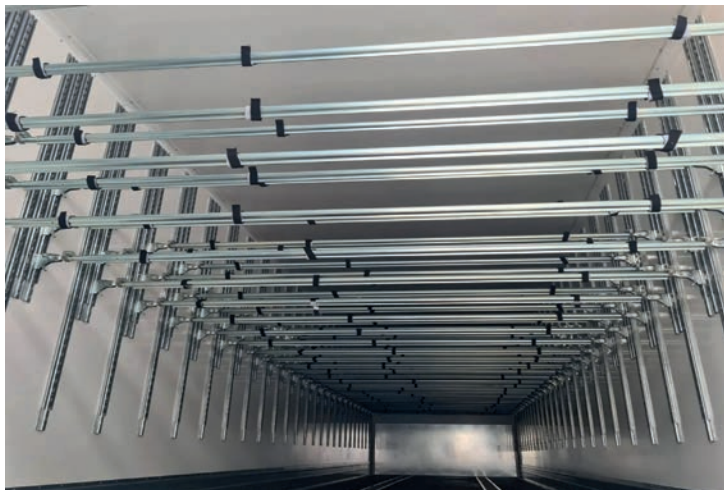

BARRA ROPA GARMENT RAIL



LOADING FASTENING SYSTEMS / LADUNGSSICHERUNG / SISTEMAS DE SUJECIÓN DE CARGA

Perfil
Profile

2301140/42/44



Accesorios
Accessories

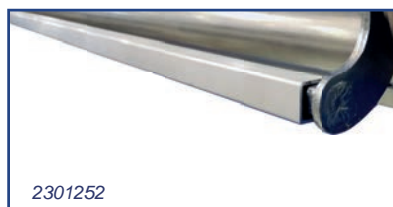

Extensible Garment Rail
Kleiderstangen Ausziehbar
Barra para Ropa Extensible

Ref	Kg	Ø	Thickn. Espesor	Lot
2301244	8	36	2.5	1

LC: 314 daN | min: 2450 - máx: 2730
Capacidad de Carga: 314 daN | min: 2450 - máx: 2730

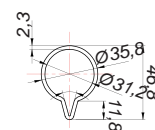
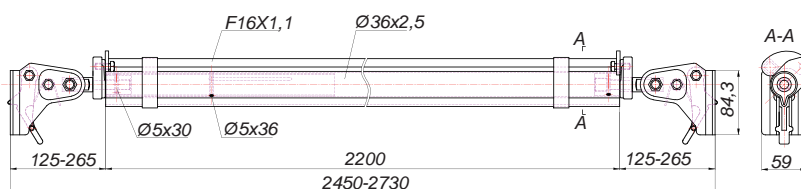

Cap for Garment Rail 2301244
Set für Kleiderstangen 2301244
Terminal p/barra 2301244

Ref	Kg	Lot	Pack
2301251	1.13	1	2





Kit 2 axes Left-Right for Garment Rail 2301242
 2 Achsen Set für Kleiderstangen 2301242
 Kit 2 Ejes Izdo-Dcho p/barra 2301242

NEW

Ref	Kg	Lot
2301250	0.42	1

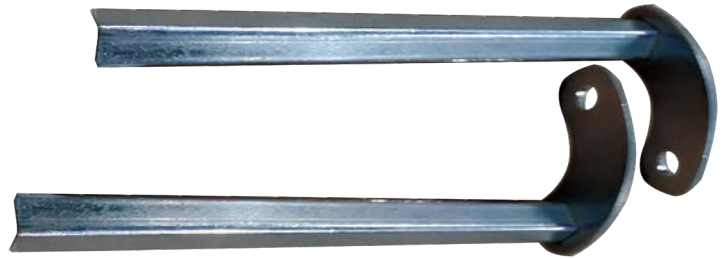

Kit 2 axes Left-Right for Garment Rail 2301244
 2 Achsen Links-Rechts Set für Kleiderstangen 2301244
 Kit 2 Ejes Izdo-Dcho p/barra 2301244

NEW

Ref	Kg	Mat	Sup/Finish Acabado	Lot
2301249	0.49	STEEL	Zn	1



Square Tube for Garment Rail
 Quadratisch Tube Für Kleiderstangen
 Tubo Cuadrado Aluminio Anodizado p/barras de ropa

NEW

Ref	Kg	Mat	Sup/Finish Acabado	A	Article	Lot
2301252	0.46		Anod	2200	for 2301244 para Barra 2301244	1
2301253	0.46		Anod	2300	for 2301242 para Barra 2301242	1

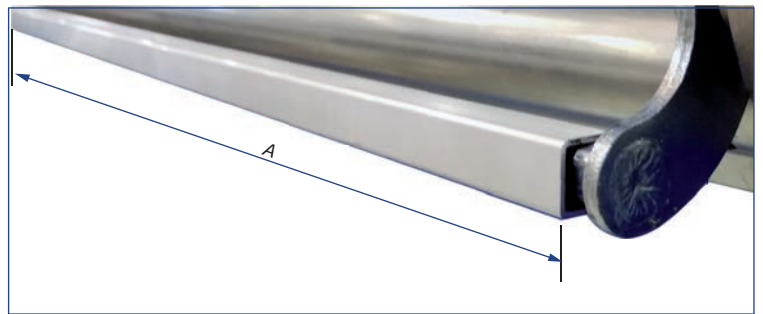

Velcro for Garment Rail 2301242/44
 Klettverschlussband für Kleiderstangen 2301242/44
 Velcros ADAICO p/barras 2301242/44

NEW

Ref	Kg	Lot	Pack
2301248	0.1	1	10





BARRA DOBLE PISO CARGA SECA - CONTENEDOR DOUBLE DECK CARGO BAR FOR DRY BOX - CONTAINERS

LOADING FASTENING SYSTEMS / LADUNGSSICHERUNG / SISTEMAS DE SUJECIÓN DE CARGA



Perfil
Profile

2301140/42/44

Accesorios
Accessories



Captive Decking Beam
Ladebalken Doppelstocksystem aus Aluminium
Barra Cautiva Doble Piso Furgón Cerrado

NEW

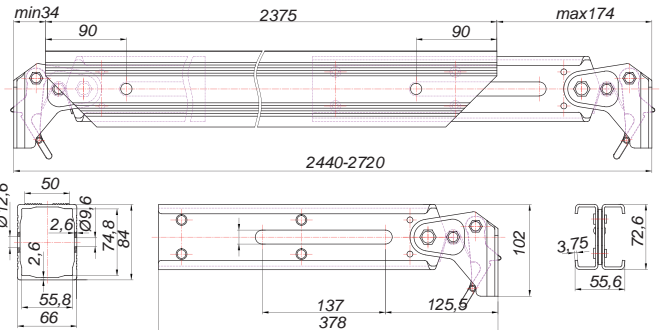

Ref	Kg	Mat	Lot
2301238	11		1

LC = 1000 daN | min: 2440 - max: 2720 | Aluminium AL6005A-T5
Capacidad de Carga: 1000 daN | min: 2440 - máx: 2720 | Aluminio AL6005A-T5



Sliding Decking Beam for COMBI Anchor Track
Sperrbalken Aluminium für COMBI Profile
Barra Carga Aluminio p/perfil COMBI

Ref	Kg	Mat	Lot
2301234	9		1

LC = 1392 daN | min: 2330 - max: 2612
Capacidad de Carga: 1392 daN | min: 2330 - máx: 2612

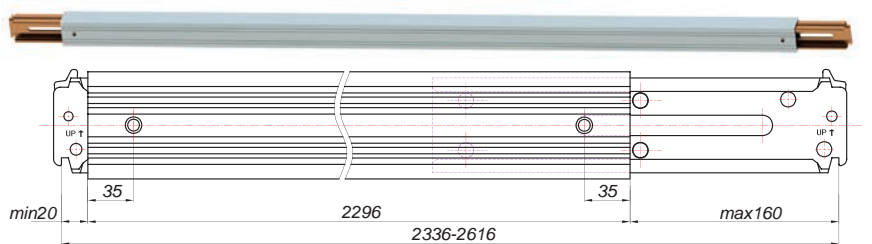

Perfil
Profile

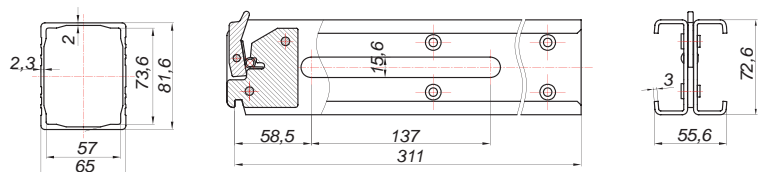
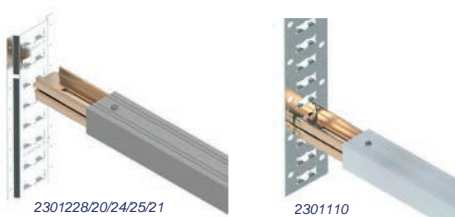



TORNOS TENSORES
ROPE TENSIONER

Lashing Drum (Ø60)
Spanngetriebe für Gurt und Seil (Ø60)
Torno Tensor Cinta-Cuerda (Ø60)

Ref	Kg	Mat	Col	Lot
1002020	2.13	STEEL	●	2

LC: 1500 daN

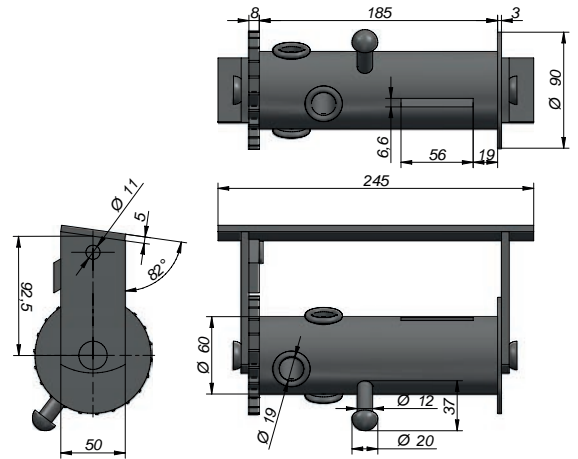

Slidable Lashing Drum (Ø60)
Spanngetriebe für Gurt und Seil (Ø60) Versetzbar
Torno Tensor Cinta-Cuerda (Ø60) Desplazable

Ref	Kg	Mat	Col	Lot
1002030	2.2	STEEL	●	2

LC: 1000 daN

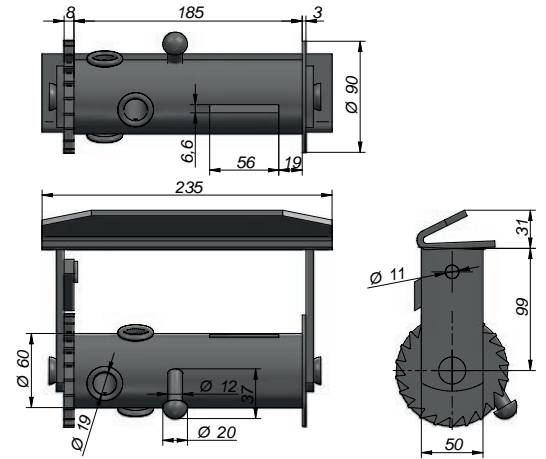

Rope Tensioner Heavy Duty (Ø60)
Spanngetriebe für Gurt für Höhe Anforderung (Ø60)
Torno Tensor Cuerda Gran Tonelaje (Ø60)

Ref	Kg	Mat	Lot
1002040	3.9	STEEL	2

LC: 2300 daN

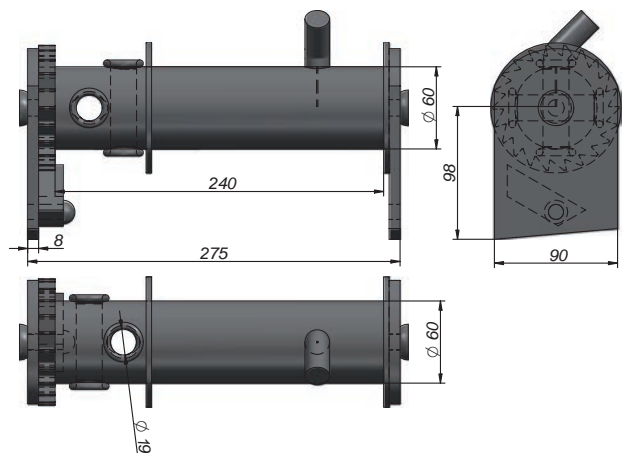
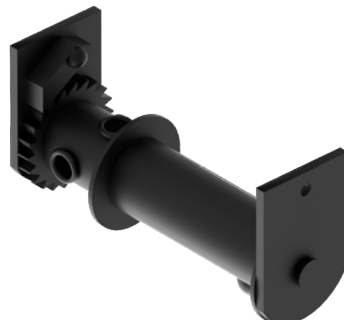

Lashing Drum (Ø48)
Spanngetriebe für Gurt (Ø48)
Torno Tensor Cinta (Ø48)

Ref	Kg	Mat	Col	Lot
1002045	4	STEEL	●	1

LC: 4800 daN

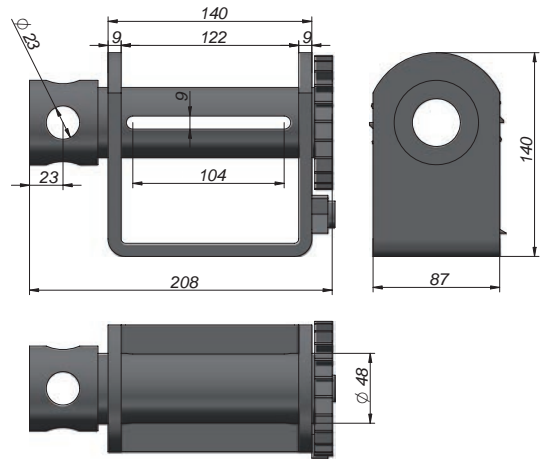

Chain Tensioner with Ring and Hook 1/2-5/8
Ratschenlastspanner Container mit Ring und Haken 1/2-5/8
Tensor de Cadena con Argolla-Gancho 1/2-5/8

Ref	Kg	Mat	Sup/Finish Acabado	Col	A	Ø	Lot
1002060	6.7	STEEL		●	1/2-5/8	23	1

WLL 13000 LBS | MBS 4000 LBS | Working limit: 5.900 kg. | Breaking limit: 20.400 Kg.
WLL 13000 LBS | MBS 4000 LBS | Limite Trabajo: 5.900 kg. | limite de Rotura: 20.400 Kg.

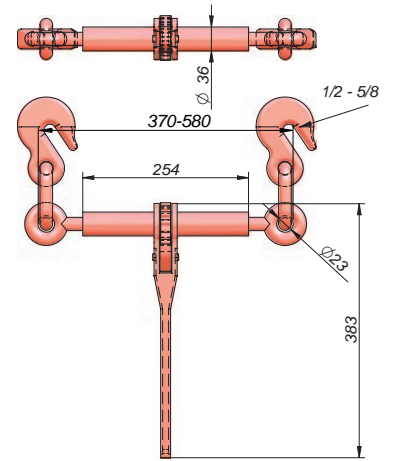

Chain Tensioner 1/2-5/8
Ratschenlastspanner Container 1/2-5/8
Tensor de Cadena 1/2-5/8

Ref	Kg	Mat	Sup/Finish Acabado	Col	A	Lot
1002064	3.92	STEEL		●	1/2-5/8	1

WLL 13000 LBS | MBS 4000 LBS | Working limit: 5.900 kg. | Breaking limit: 20.400 Kg.
WLL 13000 LBS | MBS 4000 LBS | Limite Trabajo: 5.900 kg. | limite de Rotura: 20.400 Kg.

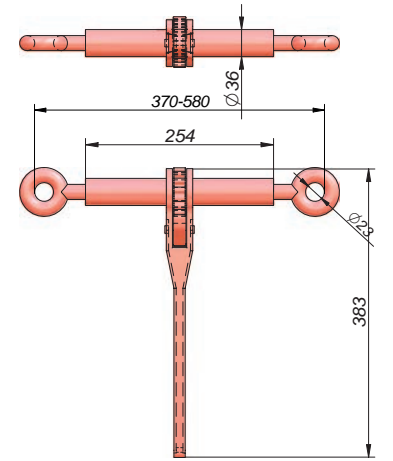

Chain Tensioner 3/8-1/2
Ratschenlastspanner Container 3/8-1/2
Tensor de Cadena 3/8-1/2

Ref	Kg	Mat	Sup/Finish Acabado	Col	A	Lot
1002066	3.5	STEEL		●	3/8-1/2	1

WLL 9200 LBS | MBS 33000 LBS | Working Limit: 4.300 kg. | Breaking Limit: 15.000 Kg.
WLL 9200 LBS | MBS 33000 LBS | Limite Trabajo: 4.300 kg. | limite de Rotura: 15.000 Kg.

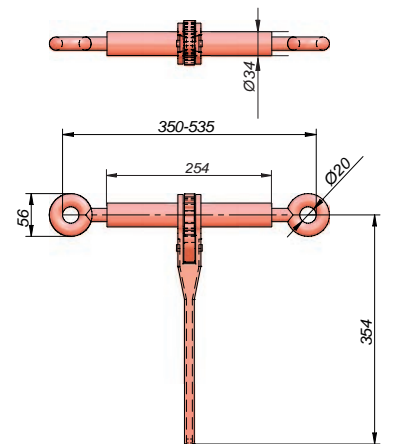

LOADING FASTENING SYSTEMS / LADUNGSSICHERUNG / SISTEMAS DE SUJECIÓN DE CARGA

ARGOLLAS RINGS



Floor Ring Steel w/Plate
Zurrbügel Stahl verzinkt m/Platte
Argolla Suelo Acero c/Pletina

Ref	Kg	Mat	Sup/Finish Acabado	Lot
1501046	0.37	Forged	Zn	4

LC > 2000 daN. | VCA Certificate
EN 12640

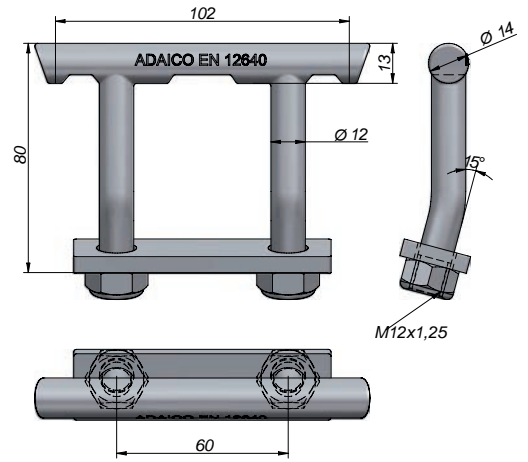

Steel Embedded Ring 95x102
Zurrring klappbar mit Platte 95x102 Stahl verzinkt
Argolla Empotrada 95x102

Ref	Kg	Mat	Sup/Finish Acabado	Thickn. Espesor	Lot
1501050	0.39	STEEL	Zn	2.5	4

LC > 2000 daN. | VCA Certificate
EN 12640

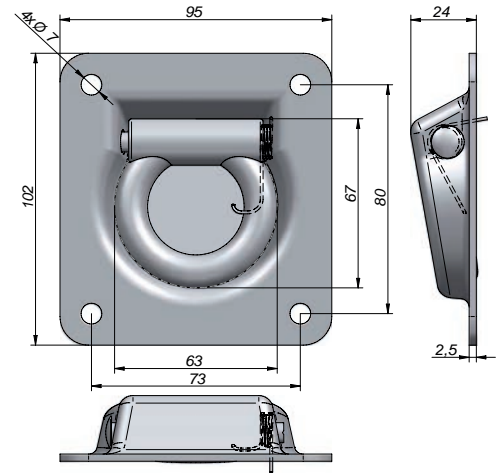

Steel Embedded Ring 125x150
Zurrring klappbar mit Platte 125x150 Stahl verzinkt
Argolla Empotrada 125x150

Ref	Kg	Mat	Thickn. Espesor	Lot
1501052	0.67	STEEL	2.5	2

With drain hole
Con agujero de desagüe.

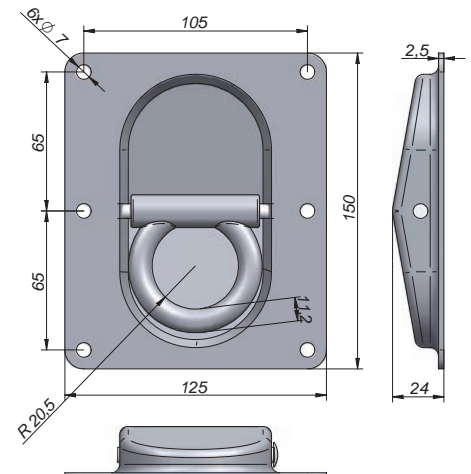

Forged Embedded Ring 97x90x29
 Zurring Stahl geschmiedet 97x90x29 zum Einschweißen
 Argolla Empotrada 97x90x29 Forjada

Ref	Kg	Mat	Thickn. Espesor	Lot
1501053	0.9	Forged	6	2

LC = 3125 daN

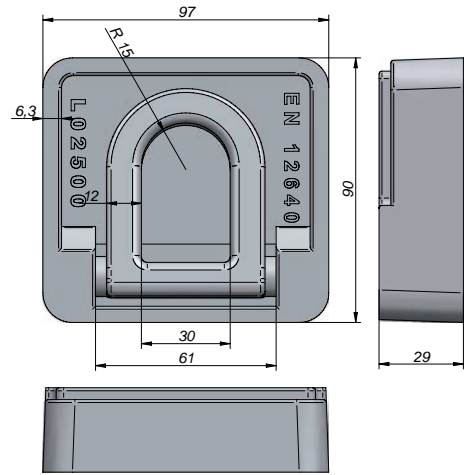
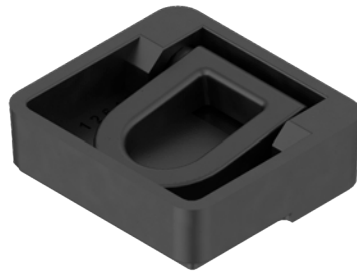

Embedded Ring 105x66 Steel
 Zurring 105x66 Stahl, versenkbar
 Argolla Empotrada 105x66 Acero

Ref	Kg	Mat	Lot
1501054	0.57	STEEL	1

LC = 3125 daN

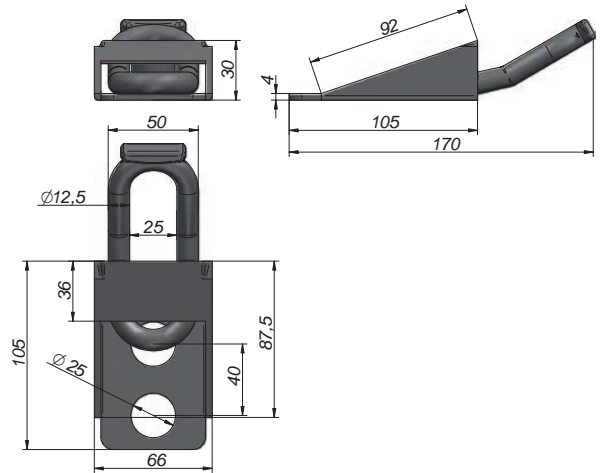

Raw Steel 7T Lashing Ring 120x120 w/support for welding
 Zurring Raw Stahl 7T 120x120 m/Halterzum Anschweissen
 Argolla 7T 120x120 Acero Bruto c/soporte soldable

NEW

Ref	Kg	Mat	Lot
1501060	1.2	STEEL	1

LC = 7000 daN
 UNI EN 12640:2019 DIN 75410-1:2003 EN 29367-2 : 2000

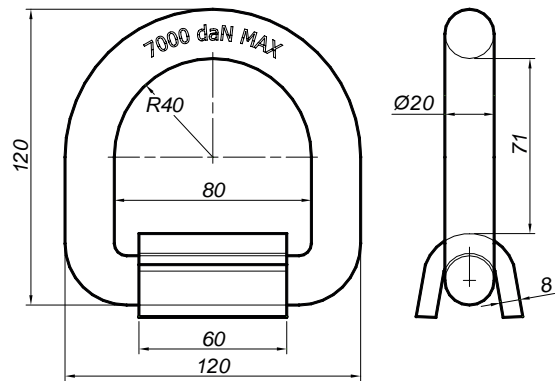

Raw Steel 12T Lashing Ring 130x150 w/support for welding
 Zurring Raw Stahl 12T 130x150 m/Halterzum Anschweissen
 Argolla 12T 130x150 Acero Bruto c/soporte soldable

NEW

Ref	Kg	Mat	Lot
1501061	2	STEEL	1

LC = 12000 daN
 EN 29367-2 : 2000

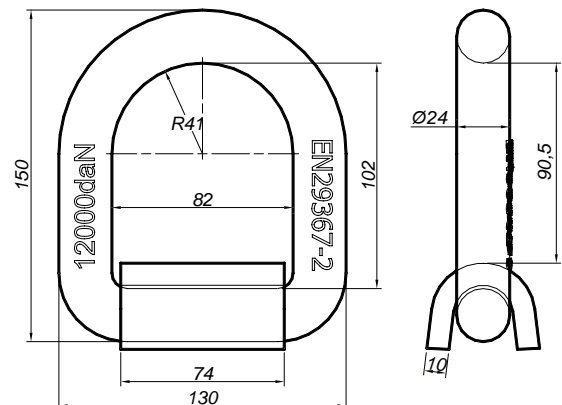

LOADING FASTENING SYSTEMS / LADUNGSSICHERUNG / SISTEMAS DE SUJECIÓN DE CARGA



RINGS / ZURRRINGE / ARGOLLAS

LOADING FASTENING SYSTEMS / LADUNGSSICHERUNG / SISTEMAS DE SUJECIÓN DE CARGA

Steel Lashing 12T Ring 130x150 w/support with holes
Zurrring Stahl Lashing 12T Ring 130x150 m/Halterwith holes
Argolla 12T 130x150 Acero c/soporte c/agujeros

NEW

Ref	Kg	Mat	Sup/Finish Acabado	Lot
1501062	2.69	STEEL	Zn	1
1501063	2.69	STEEL	Galv	1

LC = 12000 daN
EN 29367-2 : 2000

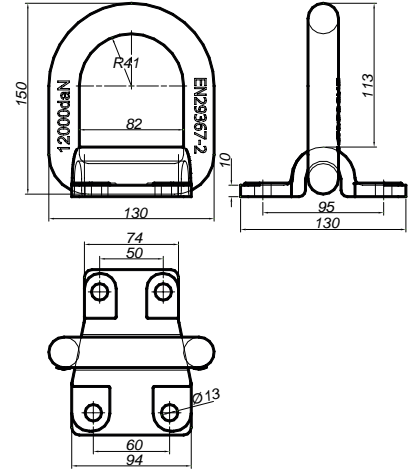

Raw Steel 15T Lashing Ring 122x150 w/support for welding
Zurrring Raw Stahl 15T 122x150 m/Halterzum Anschweissen
Argolla 15T 122x150 Acero Bruto c/soporte soldable

NEW

Ref	Kg	Mat	Lot
1501065	2.4	STEEL	1

LC = 15000 daN
UNI EN 12640:2001 DIN 75410-1:2003 EN 29367-2 : 2000

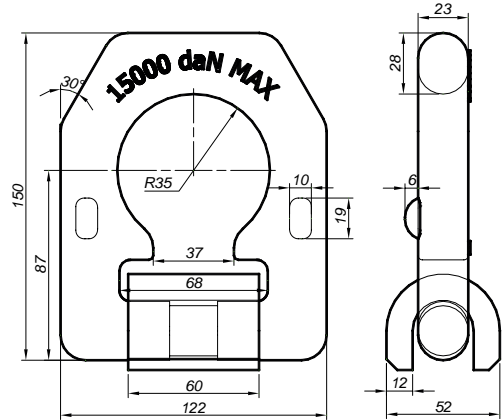

Zinc Plated Steel 15T Lashing Ring 122x150 w/plate
Zurrring Verzinkt Stahl 15T 122x150 m/Einlegeschiene
Argolla 15T 122x150 Acero Cincada c/pletina

NEW

Ref	Kg	Mat	Sup/Finish Acabado	Lot
1501066	2.81	STEEL	Zn	1

LC = 15000 daN

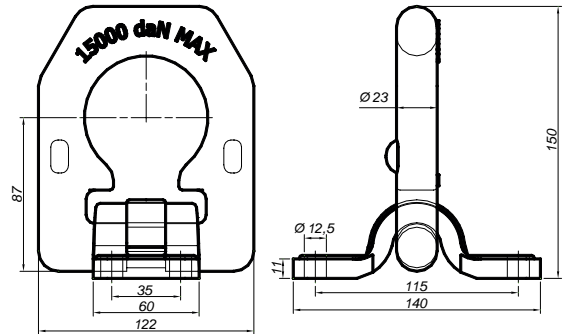

Iluminación y Señalización

Lighting and Warning

Éclairage et Signalétique

Lichter und Warnmarkierung

Iluminação e Sinalização

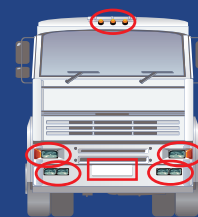

Luces Interiores

Interior Lights

Éclairage Intérieur

Innenbeleuchtung

Luzes Interiores



pag. 352-354

Pilotos

Lights

Feux

Blinker

Pilotos



pag. 355-378

Visión Trasera

Rear View Camera

Caméra De Recul

Rückfahrkamera

Câmera De Marcha Atrás



pag. 379-380

Espejos Retrovisores

Rear View Mirrors

Rétroviseurs

Spiegel

Espelhos Retrovisores



pag. 381-386

Señalización

Marking

Signalisation

Markierung

Sinalização



pag. 387-394



LUCES INTERIORES
INTERIOR LIGHTS

Ceiling Light LED Ø155
LED-Innenleuchte Ø155 12V/24V
Plafón Interior LED Ø155

Ref	Kg	V	E-mark	Lot
6901316	0.2	12/24v	E4	1

IP 67 | Cable 180 mm. fly lead | Raw Lumen: 420 | Effective Lumen: 294 | HV CD: 300
EMC R10

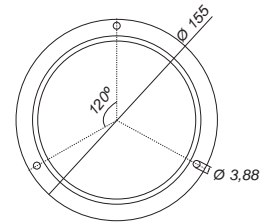

LED Ceiling Light with PIR sensor
LED-Deckenleuchte mi Sensor PIR
Plafón LED con sensor PIR

Ref	Kg	V	E-mark	Article	Lot
2569001	0.18	12/24v	E6	with PIR sensor con sensor de presencia	1
2569005	0.18	12/24v	E6	no sensor, connected to 2569001 sin sensor, se conecta al 2569001	1

21 SMD LEDs | RAW Lumen 1397 | Effective Lumen 704 | HV CD 160 | IP67 | Cable 180 mm. |
Temperature -30°C~50°C
EMC R10

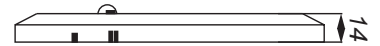
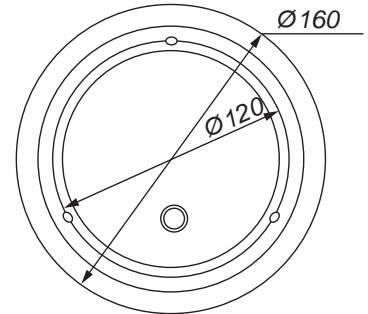

Ceiling Light Cap/Dachlampekappe
Dachlampekappe
Aro de Superficie para Plafón

Ref	Kg	Lot
6901317	0.06	1

for 6901316 and 2569001/2569005
para 6901316 y 2569001/2569005

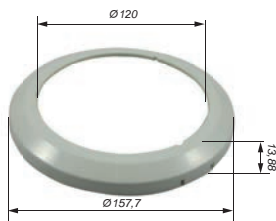

Ceiling Light Ring
Dachlampering
Aro de Empotrar para Plafones 6901316/2569001/2569005

Ref	Kg	Lot
6901318	0.03	1

for 6901316 and 2569001/2569005
para 6901316 y 2569001/2569005

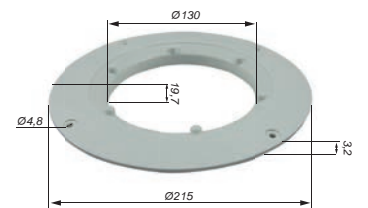

LED Ceiling Light Ø177 mm.
LED-Deckenleuchte Ø177 mm
Plafón LED Ø177 mm.

Ref	Kg	Ø	V	Lot
2569008	0.24	177	12/24V	1

39 SMD LEDs | RAW Lumen 780 | Effective Lumen 546 | HV CD 500 | IP67 | Cable 180 mm. fly lead | Temperature -30°C~50°C
39 SMD LEDs | RAW Lumen 780 | Effective Lumen 550 | HV CD 500 | IP67 | Cable 180 mm. fly lead | Temperatura -30°C~50°C | Touch Switch
EMC R10

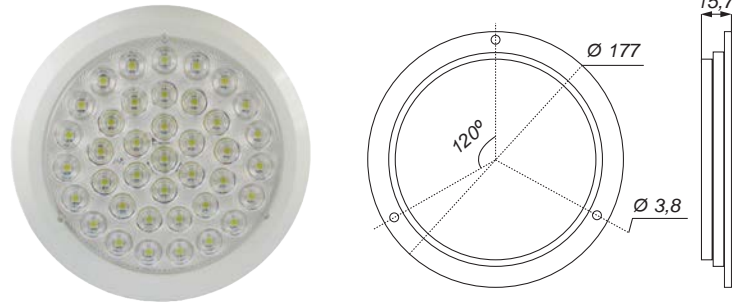

LED Ceiling Light Ø75 mm. Touch Switch
LED-Deckenleuchte Ø75 mm Touch Switch
Plafón LED Ø75 mm. Touch Switch

NEW

Ref	Kg	Ø	V	Lot
2569009	0.03	75	12/24V	1

6 LEDs | RAW Lumen 120 | Effective Lumen 85 | HV CD 35 | IP67 | Cable 100 mm. fly lead | Temperature -30°C~50°C
6 LEDs | RAW Lumen 120 | Effective Lumen 85 | HV CD 35 | IP67 | Cable 100 mm. fly lead | Temperatura -30°C~50°C
EMC R10

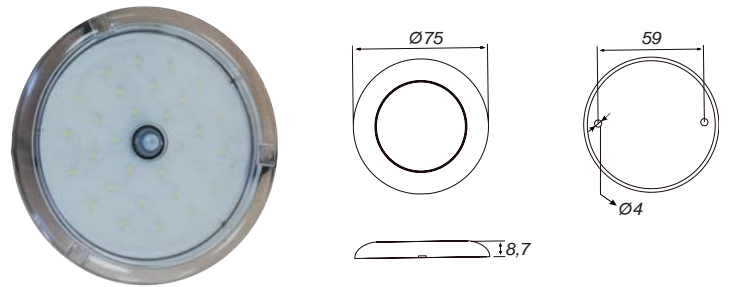

LED Interior Lamp L=400 w/switch
LED-Leiste L=400 - mit Schalter
Regleta LED L=400 c/interruptor

Ref	Kg	V	Emark	Lot
6901306	0.11	12/24V	E ₄	1

18 LEDs | Cable 100 mm. fly lead | Raw Lumen: 1197 | Effective Lumen: 600 | HV CD: 130 | Temperature -30°C~50°C
18 SMD LEDs | Raw Lumen: 1197 | Effective Lumen: 600 | HV CD: 130 | Cable 100 mm. fly lead | Temperatura -30°C~50°C
EMC R10

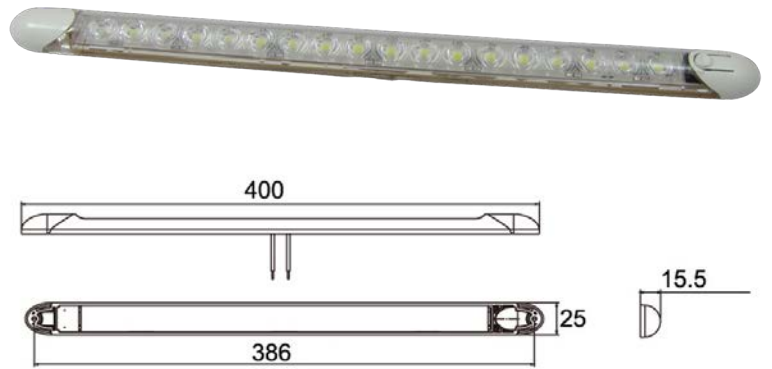

LED Interior Lamp L=250 w/switch
LED-Leiste L=250 - mit Schalter
Regleta LED L=250 c/interruptor

Ref	Kg	V	Emark	Lot
6901308	0.06	12/24V	E ₆	1

9 LEDs | Cable 180 mm. fly lead | Raw Lumen: 600 | Effective Lumen: 300 | HV CD: 140 | Temperature -30°C~50°C
9 SMD LEDs | Raw Lumen: 600 | Effective Lumen: 300 | HV CD: 140 | Cable 180 mm. fly lead | Temperatura -30°C~50°C
EMC R10

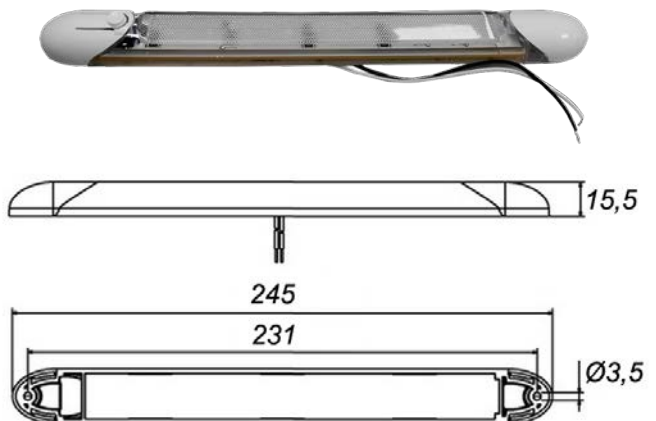

LIGHTING AND WARNING / BELEUCHTUNG UND MARKIERUNG / ILLUMINACIÓN Y SEÑALIZACIÓN



LED Ceiling Light 130X46 Rectangular
Dachlampe LED 130X46 Rechteckig
Plafón Interior Rectangular LED 130x46

Ref	Kg	V	Lot
2569010	0.07	12v	2

10 SMD LEDs | RAW Lumen 210 | Effective Lumen 147 | HV CD 48 | IP67 | Cable 150 mm. fly lead | Temperature -30°C~50°C CE

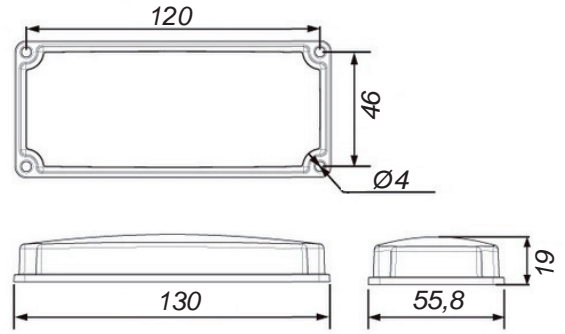

Ceiling Light LED 140x70x10 300 Lumen
Dachlampe LED 140x70x10 300 Lumen
Plafón interior Rectangular LED 140x70x10 300 Lumen

Ref	Kg	V	E-mark	Lot
2569017	0.09	12v		1
2569018	0.09	12/24v	E ₂	1

6 LEDs | 300 Lumen | 2,5W | IP69K | Housing: Polycarbonate
6 LEDs OSRAM | 300 Lumen | 2,5W | IP69K | Carcasa: Policarbonato

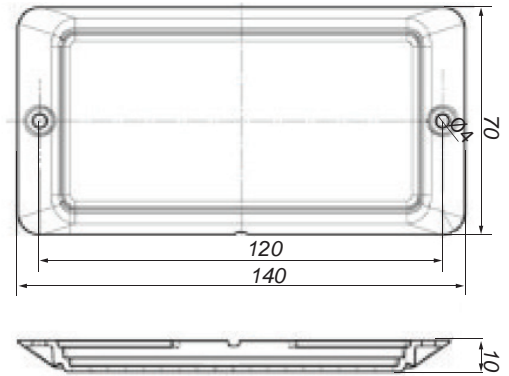

LED Ceiling Light 172x100 without switch
Dachlampe LED 172x100 ohne Schalter
Plafón Interior LED 172x100 sin Interruptor

Ref	Kg	V	Lot
2569012	0.14	12/24v	1

36 SMD LEDs | RAW Lumen 12225 | Effective Lumen 1222 | HV CD 354 | IP67 | Cable 170 mm. fly lead | Temperature -30°C~50°C

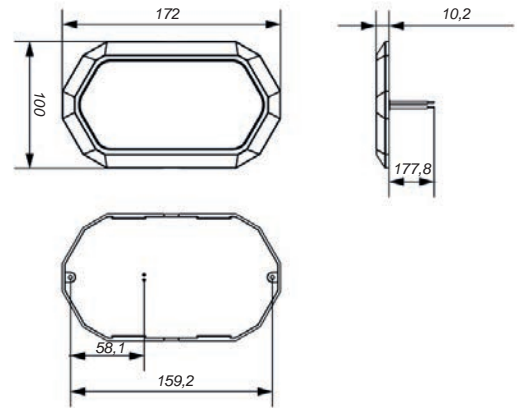

Round Ceiling Light LED 114x22
Dachlampe LED 114x22
Plafón interior LED 114x22

Ref	Kg	Ø	V	Lot
2569015	0.09	11.4	12v	1

18 LEDs | RAW Lumen 600 | Effective Lumen 390 | HV CD 101 | Frosted Polycarbonate Lens | Surface Mounting | Cable 160 mm. fly lead
18 LEDs | RAW Lumen 600 | Effective Lumen 390 | HV CD 101 | Lentes de Policarbonato esmerilado | Montaje superficial | cable 160 mm. fly lead

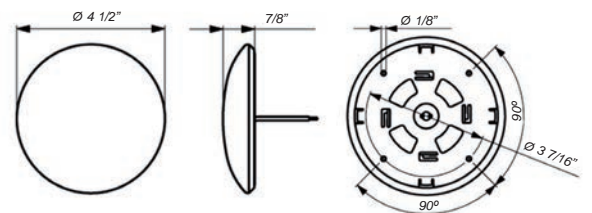



PILOTOS LATERALES SIDE LAMPS

LIGHTING AND WARNING / BELEUCHTUNG UND MARKIERUNG / ILLUMINACIÓN Y SEÑALIZACIÓN

Side Light LED with Support
LED-Seitenleuchte Gelb mit Halter
Piloto Gálibo LED c/Soportre

Ref	Kg	Col	Pos	V	Emark	Article	Function Funciones	Lot
2596060	0.08	Red		12/24v	E ₉	Cable 500 mm.		1
9698056	0.08	Yellow		12/24v	E ₉	Cable 300 mm.		1

3 LEDs | IP67 | Includes Bracket | PRS connector
3 LEDs | IP67 | Incluye soporte | Conector PRS
ECE | EMC R10 | Australian Design Rules

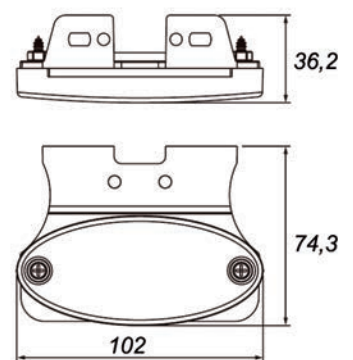

Side Light LED
Seitenleuchte LED
Piloto Gálibo LED

Ref	Kg	Col	Pos	V	Emark	Function Funciones	Lot
2596061	0.08	White		12/24v	E ₉		1

3 LEDs | IP67 | Cable 300 mm. PRS connector
3 LEDs | IP67 | Cable 300 mm. conector PRS
ECE | EMC R10 | Australian Design Rules

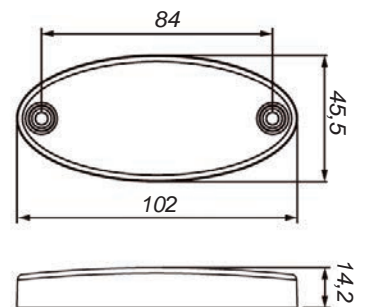

Side Light LED with Support
LED-Umrissleuchte mit Halter
Piloto Gálibo c/Soportre LED

Ref	Kg	Col	Pos	V	Emark	Article	Function Funciones	Lot
2596062	0.17	Yellow		24v	E ₄	Cable 500 mm.		1
2596065	0.2	Yellow		24v	E ₄	Cable 1.500 mm.		1

IP67 | Includes Bracket | PRS connector
Incluye soporte | IP67 | Conector PRS
ECE Approval

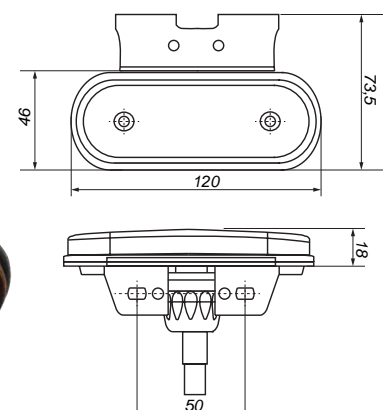



SIDE LAMP / SEITENLICHT / PILOTOS LATERALES

LIGHTING AND WARNING / BELEUCHTUNG UND MARKIERUNG / ILLUMINACIÓN Y SEÑALIZACIÓN

Marker Lamp LED Yellow
LED-Seitenleuchte Gelb
Piloto Gálbo Amarillo LED

Ref	Kg	Col	Pos	V	Emark	Function Funciones	Lot
2596069	0.1			24v	E4		1

IP67 | Cable 500 mm. PRS connector
IP67 | Cable 500 mm conector PRS
ECE Approval

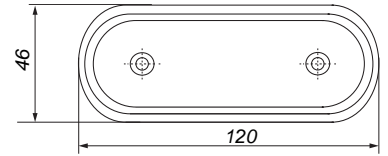

Oval Warning Light Support
Positionsleuchte Oval Halter
Soporte Piloto Gálbo Ovalado

Ref	Kg	Mat	Col	Lot
9698072	0.02			1

Compatible: 2596060/9698056/2596061/2596062/65/69

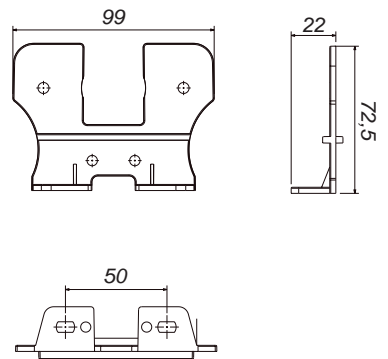

Blink Device for Side Marker Lamps LED Cable 500 mm.
Blink-Modul für Seitenmarkierungsleuchten LED Kabel 500 mm.
Dispositivo Intermitencia Gálbo LED Cable 500 mm.

Ref	Kg	Pos	V	Emark	Article	Lot
2595994	0.18		12/24v	E6	Cable 500 mm.	1

Side markers flash synchronously with D.I. | Compatible: 2596060/62/65/69 and 9698056 |
IP67 | -30~C50°C | 1 unit per side, 2 units per vehicle
Pilotos laterales parpadean sincronizado con intermitentes |
Compatible: 2596060/62/65/69 y 9698056 | IP67 | -30~C50°C | 1 x lateral, 2 x vehículo
Según ECE R48, Rev6, los vehículos de las categorías O3 y O4 (remolques >3,5t)
homologados después del 18/10/2017 | EMC R10 Approved

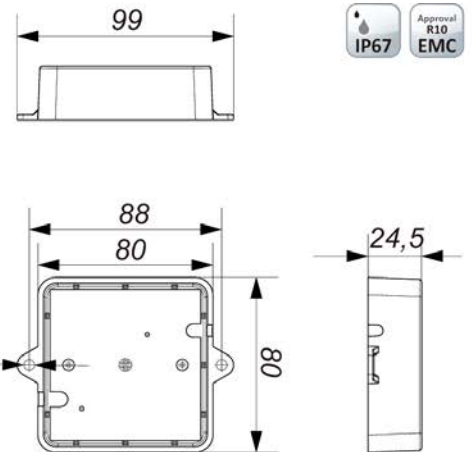

Connection Diagram

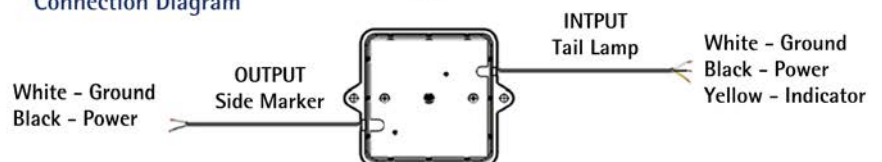

Marker Lamp LED Yellow with Bracket
LED-Seitenleuchte Gelb mit Halter
Piloto Gálbo Amarillo c/Soporte LED

Ref	Kg	Col	Pos	V	Emark	Function Funciones	Lot
2596005	0.09			12/24v			1

3 LEDs | Includes Bracket | 300 mm cable w /PRS connector | IP67
3 LEDs | Incluye soporte | Cable 300 mm. conector PRS | IP67
ECE | Australian Design Rules

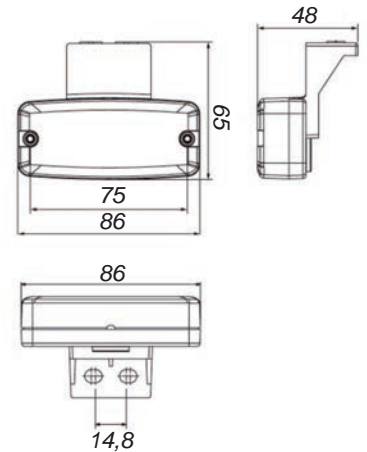

Marker Lamp LED w/Bracket w/Base
LED-Seitenleuchte Gelb mit Halter mit Boden
Piloto Gálbo c/Soporte c/Base LED

Ref	Kg	Col	Pos	V	Emark	Function Funciones	Lot
2596052	0.12			24v			10
2596053	0.12			24v			10

IP67 | Cable 500 mm. PRS connector
IP67 | Cable 500 mm conector PRS
ECE Approval

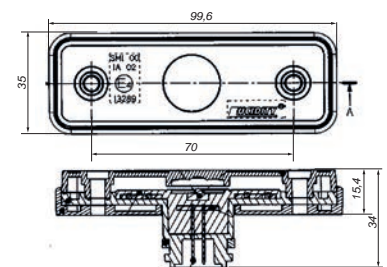

Warning Light LED intermittent with Cable
Seiten-Blinkleuchte LED mit Kabel
Piloto Gálbo LED Intermitente con Cable

Ref	Kg	Col	Pos	V	Emark	Article	Function Funciones	Lot
2595996	0.08			12/24v				1

Light: LED | Superior optic design to meet ECE R6 CAT 5 homologation | Reflex | Cable 500 mm. | IP67
Luz: LED | Diseño óptico superior para cumplir con la homologación ECE R6 CAT 5 | Reflex | Cable 500 mm. | IP67
ECE | Australian Design Rules

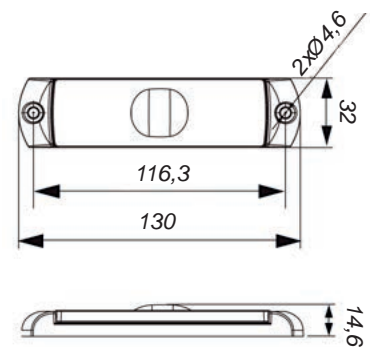

Warning Light LED intermittent, with bracket with Cable
Seiten-Blinkleuchte LED mit Halterung, mit Kabel
Piloto Gálbo LED Intermitente c/Soporte c/Cable

Ref	Kg	Col	Pos	V	Emark	Article	Function Funciones	Lot
2595998	0.06			12/24v				1

Light: LED | Superior optic design to meet ECE R6 CAT 5 homologation | Reflex | Cable 500 mm. | IP67 | Bracket included (9698070)
Luz: LED | Diseño óptico superior para cumplir con la homologación ECE R6 CAT 5 | Reflex | Cable 500 mm. | IP67 | Incluye soporte (9698070)
ECE | Australian Design Rules

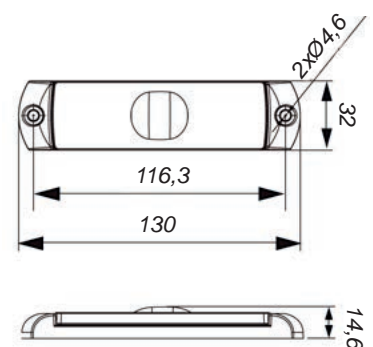



SIDE LAMP / SEITENLICHT / PILOTOS LATERALES

LIGHTING AND WARNING / BELEUCHTUNG UND MARKIERUNG / ILLUMINACIÓN Y SEÑALIZACIÓN

Warning Light LED
Warnlicht LED
Piloto Gálibo LED

Ref	Kg	Col	Pos	V	Emark	Function Funciones	Lot
2596007	0.17	Orange	Left	12/24v	E4	Warning	1
2596009	0.17	Red	Left	12/24v	E4	Warning	1
2596011	0.17	White	Left	12/24v	E4	Warning	1

Light: LED | Reflex | IP67 | Cable 500 mm. PRS connector
Luz: LED | Reflex | IP67 | Cable 500 mm conector PRS
ECE | Australian Design Rules

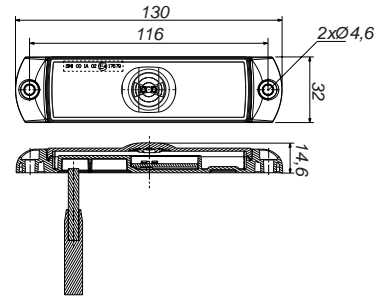

Warning Light LED
LED-Positionsleuchte
Piloto Gálibo LED

Ref	Kg	Col	Pos	V	Emark	Function Funciones	Lot
9698064	0.25	White	Left	24v	E4	Warning	1
9698066	0.25	Red	Left	24v	E4	Warning	1
9698068	0.25	Orange	Left	24v	E4	Warning	1

Light: LED | Reflex | IP67 | Cable 500 mm. PRS connector
Luz: LED | Reflex | IP67 | Cable 500 mm conector PRS
ECE | Australian Design Rules

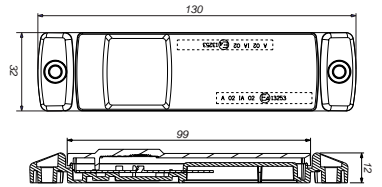

Warning Light Support
Positionsleuchte Halter
Soporte Piloto Gálibo

Ref	Kg	Lot
9698070	0.1	1

Compatible: 2595996/2595998/2596007/09/11/9698064/66/68

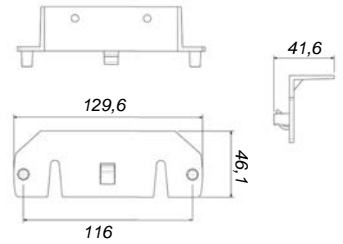

Marker Lamp LED without Brackett, Cable 500 mm.
LED-Seitenleuchte ohne Halter, Kabel 500 mm.
Piloto Gálibo LED sin Soporte Cable 500 mm.

Ref	Kg	Col	Pos	V	Emark	Function Funciones	Lot
2596067	0.85	White	Left	12/24v	E4	Warning	1
2596068	0.85	Orange	Left	12/24v	E4	Warning	1

Cable 500 mm. | IP67
ECE

NEW

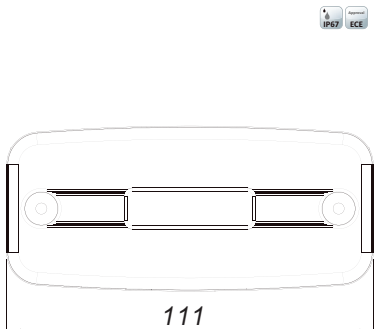

Warning Light Red LED with Black Housing
LED-Warnlicht Rot mit Gehäuse Schwarz
Piloto Galibo LED Rojo c/Carcasa Negra

Ref	Kg	Col	Pos	V	Emark	Lot
2596048	0.05			12/24v		2

LED | 500 mm. cable | IP67
LED | Cable 500 mm. | IP67
Australian Design Rules

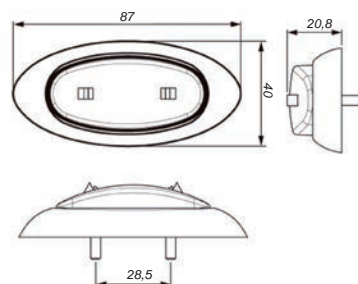

Warning Light White LED with Black Housing
LED-Warnlicht Weiß mit Gehäuse Schwarz
Piloto Galibo LED Blanco c/Carcasa Negra

Ref	Kg	Col	Pos	V	Emark	Lot
2596050	0.05			12/24v		1

LED | 500 mm. cable | IP67
LED | Cable 500 mm. | IP67
Australian Design Rules

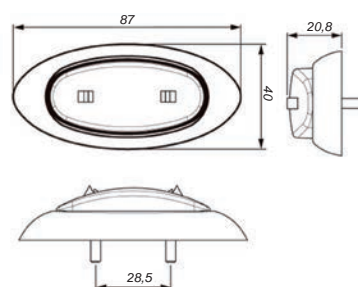

Marker Lamp LED
Warnlicht LED
Piloto Galibo LED

Ref	Kg	Col	Pos	V	Emark	Lot
2596056	0.3			12/24v		1
2596057	0.3			12/24v		1
2596058	0.3			12/24v		1

LED | IP67 | 140 mm. cable
LED | IP67 | Cable: 140 mm.
ECE | Australian Design Rules

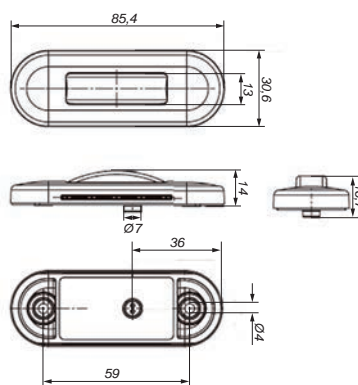

Marker Lamp LED 3,5 m. Cable without Connector
Warnlicht LED Kabel 3,5 m. ohne Stecker
Piloto Galibo LED Cable 3,5 m. sin Conector

Ref	Kg	Col	Pos	V	Emark	Lot
2596064	0.1			12/24v		1
2596066	0.1			12/24v		1

LED | IP67 | 3,5 m. cable
LED | IP67 | Cable: 3,5 m.
ECE | Australian Design Rules

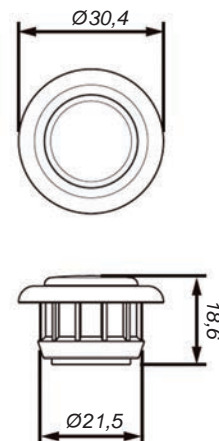



SIDE LAMP / SEITENLICHT / PILOTOS LATERALES

LIGHTING AND WARNING / BELEUCHTUNG UND MARKIERUNG / ILUMINACIÓN Y SEÑALIZACIÓN

Pack 10 units Cover of click in PRS Connector
Pack 10 units Clip PRS-Anschluss
Pack 10 uds Clip Conector PRS

Ref	Kg	Lot	Pack
9698082	0.3	1	10

Clip for PRS connectors
Clip para conectores PRS

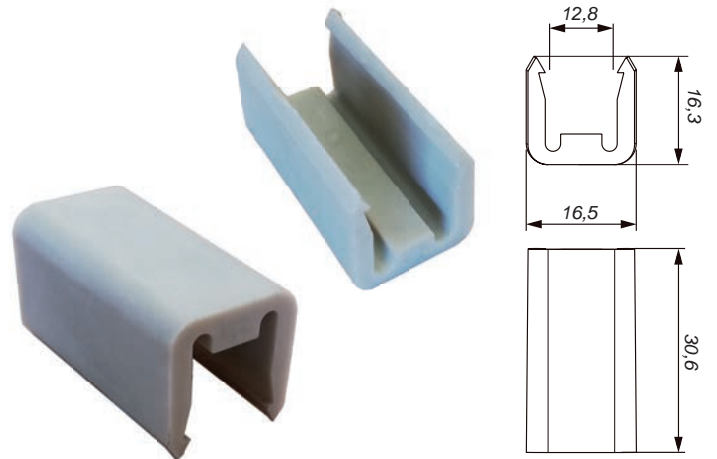

Flat PRS Cable with 2 Cores
100m-Rolle 2-adriges Kabel PRS
Rollo Cable Plano Universal PRS 2 núcleos

Ref	Kg	Article	Lot
2597012	17		1

Flat cable with 2 cores | Cross Sectional Area of cores: 2x1,5 mm²
Doble Núcleo | Área Sección transversal núcleos: 2x1,5 mm²

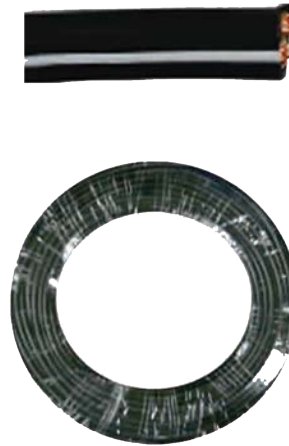

3rd Stop Lamp
3. Stop-Licht LED
Tercera Luz de Freno

Ref	Kg	V	Emark	Function Funciones	Lot
2596024	0.13	12/24v	E ₄		1
9698062	0.08	12/24v	E ₄		1

LED | IP67 | Cable 190 mm. fly lead
ECE

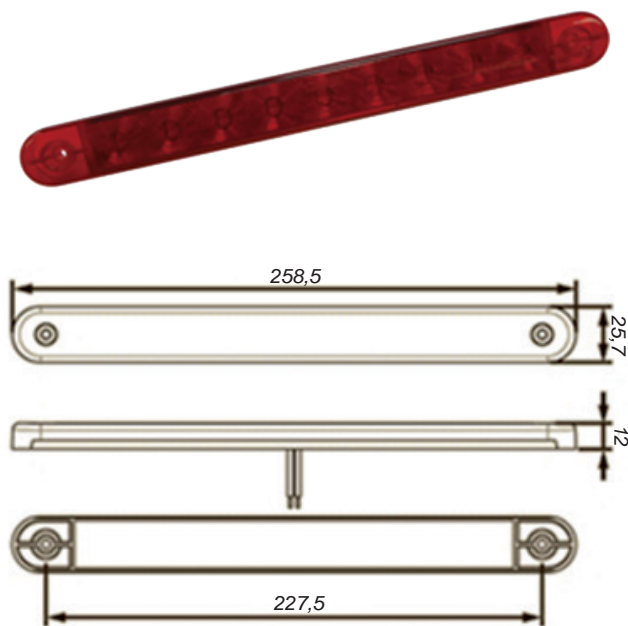



FAROS TRASEROS
REAR LIGHT

Rear Light LED 6 in 1
LED-Heckleuchte 6 in 1
Piloto Trasero LED 6 en 1

Ref	Kg	Pos	V	Emark	Function Funciones	Lot
2596040	0.57		12/24v	E6		1
2596042	0.57		12/24v	E6		1

LED | IP67 | Cable 2.000 mm.
ECE | EMC R10

2596040



IP67
EMC
ECE

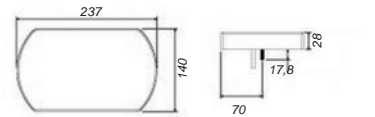
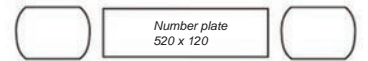

2596042

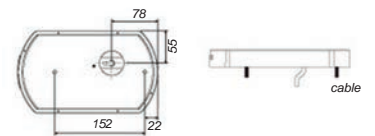
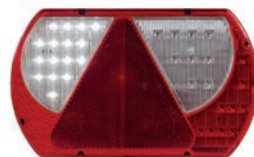

Rear Light LED 150x80
LED-Heckleuchte 150x80
Piloto Trasero LED 150x80

Ref	Kg	Pos	V	Emark	Function Funciones	Lot
2596046	0.24		12/24v	E6		1

SMD LEDs | IP67 | cable 300 mm.
ECE

Glo
IP67
Approval
ECE

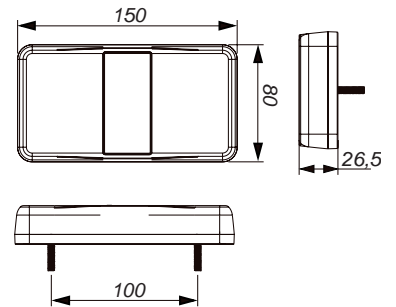

Rear Light LED 6 in 1
Hintere Lichter LED 6 in 1
Piloto Trasero LED 6 en 1

Ref	Kg	Pos	V	Emark	Article	Function Funciones	Lot
2596078	0.9		12/24v	E6	7-Pins 7 pines		1
2596079	0.9		12/24v	E6	7-Pins 7 pines		1
2596080	1.1		12/24v	E6	Cable 2 m.		1
2596081	1.1		12/24v	E6	Cable 2 m.		1

SMD LEDs | IP67 | Glo-Trac optical technology
ECE

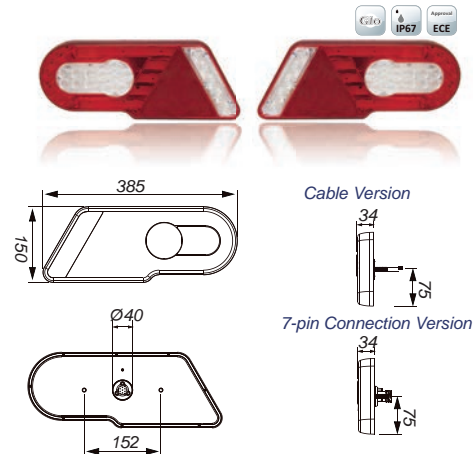

Glo
IP67
Approval
ECE

Cable Version

7-pin Connection Version



REAR LIGHT / HINTERE LICHTER / FAROS TRASEROS

LIGHTING AND WARNING / BELEUCHTUNG UND MARKIERUNG / ILLUMINACIÓN Y SEÑALIZACIÓN

Rear Light LED 7 in 1 Trailer Version
Hintere Lichter LED 7 in 1 Anhänger
Piloto Trasero LED Remolque 7 en 1

Ref	Kg	Pos	V	Emark	Function Funciones	Lot
2596036	1.47		12/24v	E6		1
2596037	1.47		12/24v	E6		1

SMD LEDs | IP67 | 7-pin connector
SMD LEDs | IP67 | Conector 7-pin
ECE | Australian Design Rules

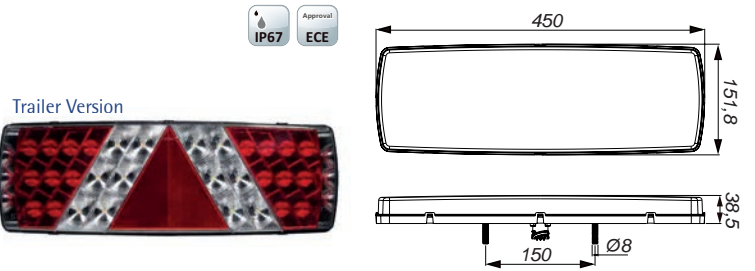

Rear Light LED 7 in 1 Truck Version
Hintere Lichter LED 7 in 1 Zugmaschine
Piloto Trasero LED Tractora 7 en 1

Ref	Kg	Pos	V	Emark	Function Funciones	Lot
2596038	1.47		12/24v	E6		1
2596039	1.47		12/24v	E6		1

SMD LEDs | IP67 | 7-pin connector
SMD LEDs | IP67 | Conector 7-pin
ECE | Australian Design Rules

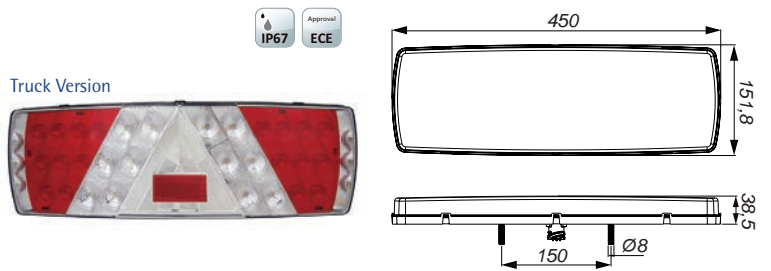

Rear Light LED 6 in 1, Cable 2.000mm.
Hintere Lichter LED 6 in 1, kabel 2.000mm.
Piloto Trasero LED 6 en 1 c/Cable 2.000mm.

Ref	Kg	Pos	V	Emark	Function Funciones	Lot
2596093	0.68		12/24v	E6		1
2596094	0.68		12/24v	E6		1

SMD LEDs | IP67 | 2000mm. Cable
SMD LEDs | IP67 | Cable 2000 mm.
ECE



Rear Light LED 6 in 1 LED Hor-Ver, Cable 500mm.
Hintere Lichter LED 6 in 1 Hor-Ver, kabel 500mm.
Piloto Trasero LED 6 en 1 Hor-Ver c/Cable 500mm.

Ref	Kg	Pos	V	Emark	Function Funciones	Lot
2596096	0.45		12/24v	E6		1

SMD LEDs | IP69K | 500mm. Cable | Glo-Trac optical Technology
SMD LEDs | IP69K | Cable 500mm. | Glo-Trac optical Technology
ECE | EMC R10

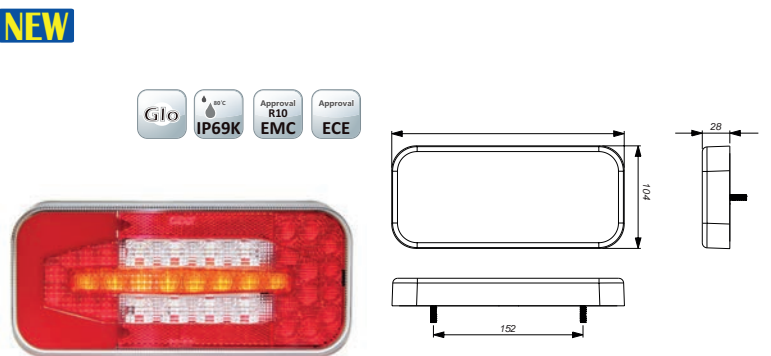



Rear Light LED 8 in 1 GloTrac 370x117,7
 Heckleuchte Links LED 8 in 1 GloTrac 370x117,7
 Piloto Trasero LED 8 en 1 GloTrac 370x117,7

Ref	Kg	Pos	V	Emark	Function Funciones	Lot
2596082	1.94		24v	E ₆		1
2596083	1.94		24v	E ₆		1

SMD LEDs | IP65 | Replaceable Lens (reduce cost maintenance) | 7-pin connector | Progressive LED -D.I. | Glo-Trac optical Technology
 SMD LEDs | IP65 | Lentes reemplazables (mantenimiento) | Conector 7-pin | Intermitente progresivo LED | Glo-Trac optical Technology
 ECE | EMC R10

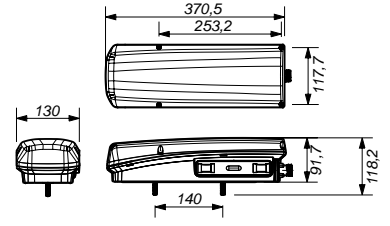

Rear Light LED 8 in 1 GloTrac 504,5x114
 Heckleuchte Rechts LED 8 in 1 GloTrac 504,5x114
 Piloto Trasero LED 8 en 1 GloTrac 504,5x114

Ref	Kg	Pos	V	Emark	Function Funciones	Lot
2596085	2.12		24v	E ₆		1
2596086	2.12		24v	E ₆		1

SMD LEDs | IP69K | Replaceable Lens (reduce cost maintenance) | Sealed AMP connector | Progressive LED -D.I. | Glo-Trac optical Technology
 SMD LEDs | IP69K | Lentes reemplazables (mantenimiento) | conector AMP sellado | Intermitente progresivo LED | Glo-Trac optical Technology
 ECE | EMC R10

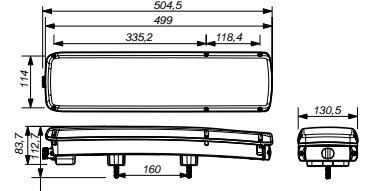

Rear Light LED 7 en 1 401,8x112,3
 Heckleuchte Rechts LED 7 in 1 - 401,8x112,3
 Piloto Trasero LED 7 en 1 401,8x112,3

Ref	Kg	Pos	V	Emark	Function Funciones	Lot
2596087	2.04		12/24v	E ₆		1
2596088	2.04		12/24v	E ₆		1

SMD LEDs | IP65 | Stainless Steel Hardware | Replaceable Lens (maintenance)
 SMD LEDs | IP65 | Hardware Acero Inox | Lentes reemplazables (mantenimiento)
 ECE | Australian Design Rules

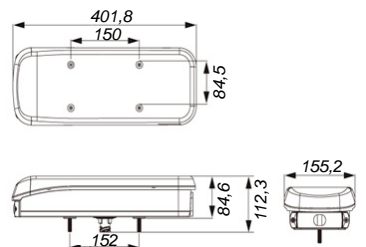

Rear Light LED 8 en 1 Glo Trac
 Heckleuchte LED 8 in 1 Glo Trac
 Piloto Trasero LED 8 en 1 Glo Trac

Ref	Kg	Pos	V	Emark	Function Funciones	Lot
2596089	2.08		12/24v	E ₆		1
2596090	2.08		12/24v	E ₆		1

SMD LEDs | IP65 | Stainless Steel Hardware | Replaceable Lens (maintenance) | Glo-Trac optical Technology | Built-in Lateral connector
 SMD LEDs | IP65 | Hardware Acero Inox | Lentes reemplazables (mantenimiento) | Glo-Trac optical Technology | Conector lateral incorporado
 ECE | Australian Design Rules

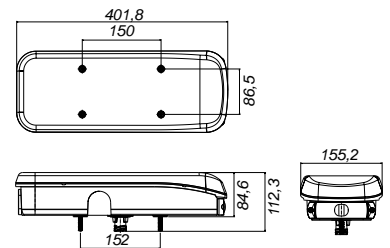



REAR LIGHT / HINTERE LICHTER / FAROS TRASEROS

LIGHTING AND WARNING / BELEUCHTUNG UND MARKIERUNG / ILLUMINACIÓN Y SEÑALIZACIÓN

Rear Light LED DAF Multifunction 8pin Connector
LED-Heckleuchte DAF Multifunktion 8pin Connector
Piloto Trasero LED DAF Multifunción Conector 8pin

Ref	Kg	Pos	V	Emark	Function Funciones	Lot
2596110	1.94		24v	E6		1
2596112	1.94		24v	E6		1

SMD LEDs | IP67 | Glo-Trac optical Technology | Replaceable Lens (maintenance) | Built-in Lateral connector
SMD LEDs | IP67 | Glo-Trac optical Technology | Lentes reemplazables | Conector lateral incorporado
ECE | Australian Design Rules

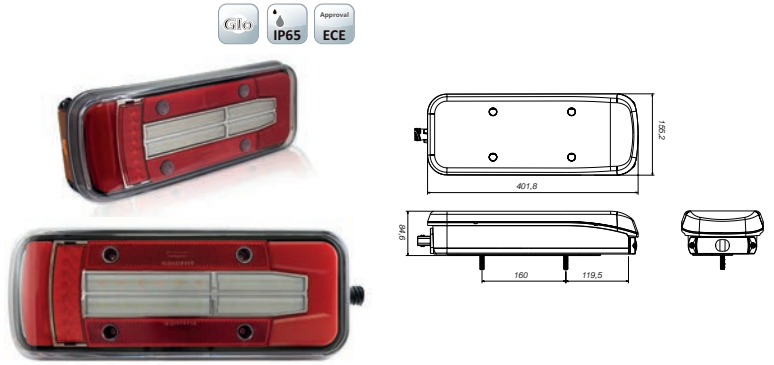

Rear Light LED SCANIA/MAN Multifunction 7pin Connector
LED-Heckleuchte SCANIA/MAN Multifunktion 7pin Connector
Piloto Trasero LED SCANIA/MAN Multifunción Conector 7pin

Ref	Kg	Pos	V	Emark	Function Funciones	Lot
2596114	1.94		24v	E6		1
2596116	1.94		24v	E6		1

SMD LEDs | IP67 | Glo-Trac optical Technology | Replaceable Lens (maintenance) | Built-in Lateral connector
SMD LEDs | IP67 | Glo-Trac optical Technology | Lentes reemplazables | Conector lateral incorporado
ECE | Australian Design Rules

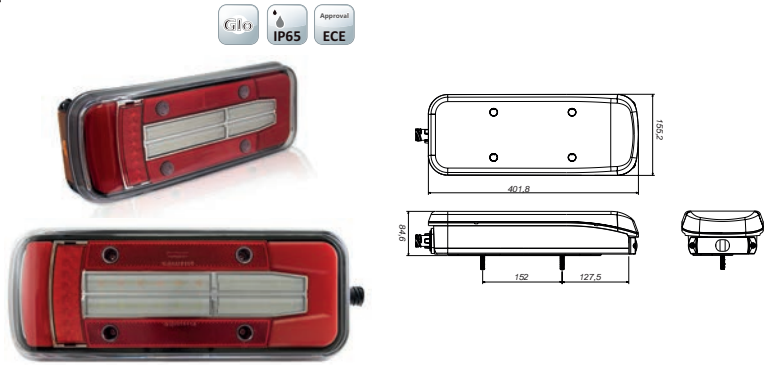

Rear Light LED VOLVO Multifunction 7pin Connector
LED-Heckleuchte VOLVO Multifunktion 7pin Connector
Piloto Trasero LED VOLVO Multifunción Conector 7pin

Ref	Kg	Pos	V	Emark	Function Funciones	Lot
2596118	1.94		24v	E6		1
2596120	1.94		24v	E6		1

SMD LEDs | IP67 | Glo-Trac optical Technology | Replaceable Lens (maintenance) | Built-in Lateral connector
SMD LEDs | IP67 | Glo-Trac optical Technology | Lentes reemplazables | Conector lateral incorporado
ECE | Australian Design Rules

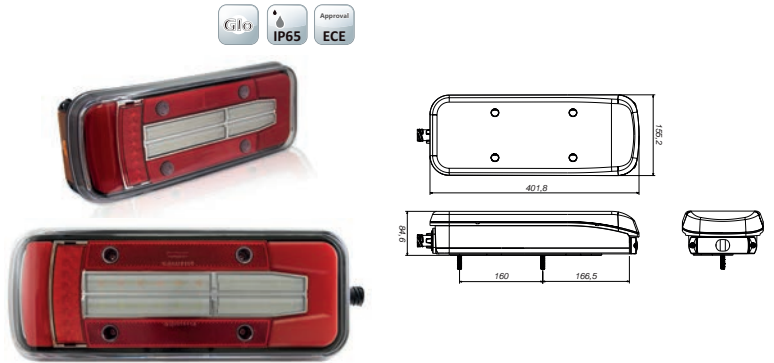

LED Rear Combination Lamp
Hintere Lichter LED mit Nummernschildhalter Lichter
Piloto Trasero Multifunción LED con luz matrícula

Ref	Kg	Pos	V	Emark	Function Funciones	Lot
2596084	0.15		12v	E6		1

SMD LEDs | IP67 | Homologated for plate sizes: 520x120 mm. y 340x240 mm. | 500 mm. Cable
SMD LEDs | IP67 | Homologada para tamaños de placas: 520x120 mm. y 340x240 mm. | cable 500 mm.
ECE | Australian Design Rules

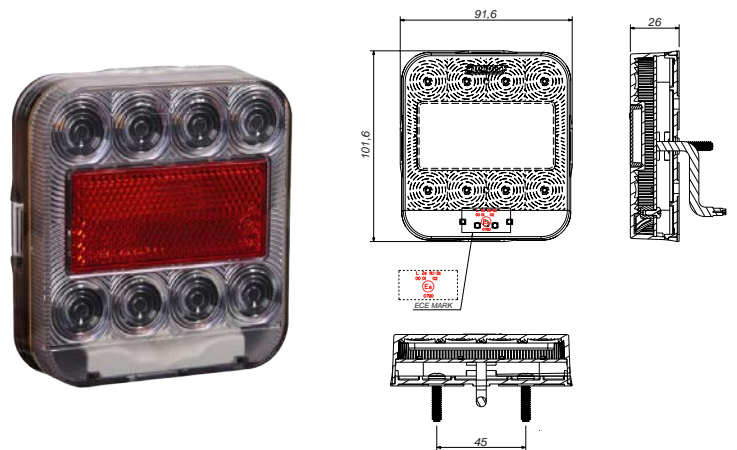

Round Lamp LED Stop-Tail-D.I.
LED-Heckleuchte Rund Stop-/Rückfahrlicht
Piloto Trasero Redondo LED Freno-Intermitente

Ref	Kg	Pos	V	Emark	Function Funciones	Lot
2596043	0.05		12/24v			1

LED | IP67 | Cable 300 mm.
ECE | EMC R10

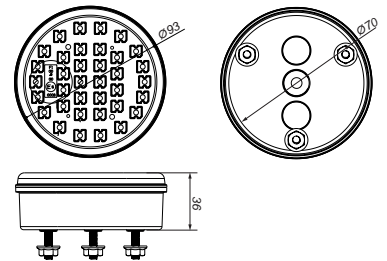

Round Lamp LED Reverse-Fog
LED-Heckleuchte Rund Nebelleuchte/Rückfahrlicht
Piloto Trasero Redondo LED Marcha atrás-Antiniebla

Ref	Kg	Pos	V	Emark	Function Funciones	Lot
2596044	0.05		12/24v			1

LED | IP67 | Cable 300 mm.
ECE | EMC R10

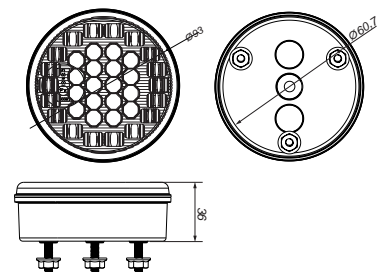

Slim LED Rear Light Bar - 3-in-1 functions
3-in-1 Stop-Licht LED
Barra Multifunción 3 en 1 Cable

Ref	Kg	Pos	V	Emark	Function Funciones	Lot
2595800	0.17		12/24v			1

SMD LEDs | IP67 | Ideal for caravans and motorhome |
3-in-1 functions: stop, tail and direction indicator | Cable 1000 mm.
SMD LEDs | IP67 | Ideal para caravanas y autocaravanas |
3 Funciones en 1 | cable 1000 mm.
ECE | EMC R10

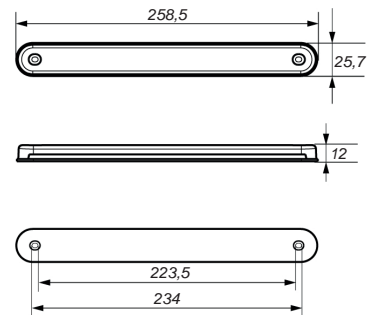



PILOTOS DE GÁLIBO END OUTLINE MARKER

Curved End Outline Marker Lamp LED with cap
LED-Umrissleuchte Rechts mit Gummifuß
Piloto Anchura LED A/R/C Curvado c/Terminal

Ref	Kg	Col	Pos	V	Emark	Lot
9698050	0.23			24v		1
9698052	0.23			24v		1

SMD LEDs | IP67 | 500 mm. cable PRS connector | Multifunción 3 in 1
SMD LEDs | IP67 | Cable 500 mm. conector PRS | Multifunción 3 en 1
ECE | EMC R10

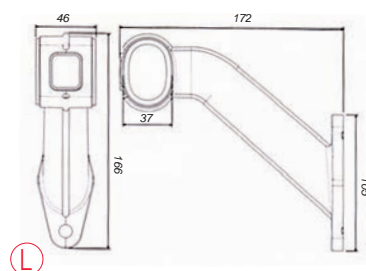

End Outline Marker Lamp LED 3-in-1 Left-Right
LED-Umrissleuchte mit Gummiarm 3-in-1 Links-Rechts
Piloto Anchura LED Reversible (Izq-Dcho)

Ref	Kg	Col	V	Emark	Lot
2596012	0.18		12/24v		1

SMD LEDs | IP 67 | 500 mm cable PRS connector
SMD LEDs | IP 67 | Cable 500 mm conector PRS
ECE | Australian Design Rules

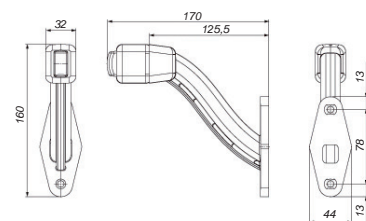

End Outline Marker Lamp LED 3-in-1 A/R/C
Umrissleuchte LED 3-in-1A/R/C
Piloto Anchura LED 3 en 1 A/R/C

Ref	Kg	Col	Pos	V	Emark	Lot
2596070	0.2			12/24v		1
2596071	0.2			12/24v		1

SMD LEDs | IP67 | 500 mm. cable PRS connector | Multifunción 3 in 1
SMD LEDs | IP67 | Cable 500 mm. conector PRS | Multifunción 3 en 1
ECE Approval

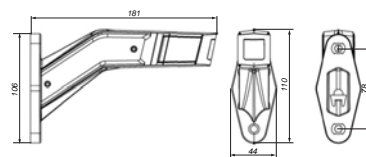

Cobra End Outline Marker Lamp LED 3-in-1 L=182
 LED-Umrissleuchte mit Gummiarm Links A/R/C 3-in-1 L=182
 Piloto Anchura "Cobra" LED 3 en 1 A/R/C L=182



Ref	Kg	Col	Pos	V	Emark	Lot
2596072	0.2			12/24v	E4	1
2596073	0.2			12/24v	E4	1

SMD LEDs | IP67 | 500 mm. cable PRS connector | Multifunccion 3 en 1 Black Polycarbonate Shell |
 Forma aerodinámica
 SMD LEDs | IP67 | Cable 500 mm. conector PRS | Multifunción 3 en 1 Carcasa Policarbonato Negra |
 Forma aerodinámica
 ECE | EMC R10

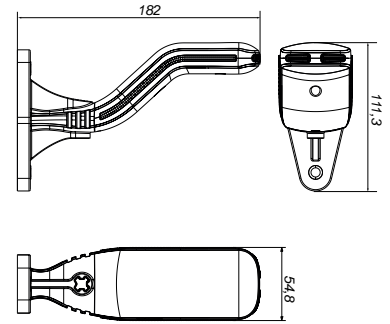

Cobra End Outline Marker Lamp LED 3-in-1 L=123
 LED-Umrissleuchte mit Gummiarm Links A/R/C 3-in-1 L=123
 Piloto Anchura "Cobra" LED 3 en 1 A/R/C L=123



Ref	Kg	Col	Pos	V	Emark	Lot
2596076	0.16			12/24v	E4	1
2596077	0.16			12/24v	E4	1

SMD LEDs | IP67 | 500 mm. cable PRS connector | Multifunccion 3 en 1 Black Polycarbonate Shell |
 Forma aerodinámica
 SMD LEDs | IP67 | Cable 500 mm. conector PRS | Multifunción 3 en 1 Carcasa Policarbonato Negra |
 Forma aerodinámica
 ECE | EMC R10

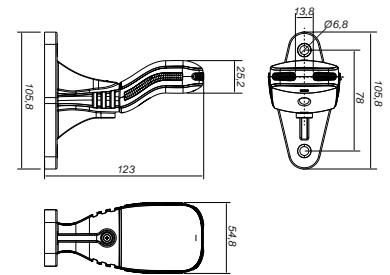

End Outline Marker Lamp LED with cap
 LED-Umrissleuchte mit Gummifuß
 Piloto Anchura LED Recto c/Terminal



Ref	Kg	Col	V	Emark	Lot
9698054	0.2		12/24v	E4	1

SMD LEDs | IP67 | 500 mm. cable PRS connector | Multifunccion 3 en 1
 SMD LEDs | IP67 | Cable 500 mm. conector PRS | Multifunción 3 en 1
 ECE | EMC R10

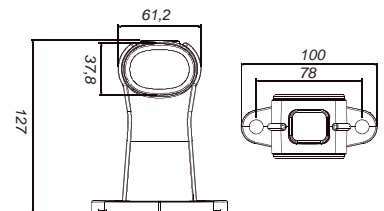

Side Marker Lamp 2-in-1 White-Red LED
 LED-Umrissleuchte 2-in-1 Weiss-Rot mit Gummifuss
 Piloto Anchura LED 2 en 1 Blanco-Rojo



Ref	Kg	Col	V	Emark	Lot
2596016	0.2		12/24v	E6	1

SMD LEDs | IP67 | 300 mm. cable PRS connector | Multifunccion 2 in 1
 SMD LEDs | IP67 | Cable 300 mm. conector PRS | Multifunción 2 en 1
 ECE | EMC R10

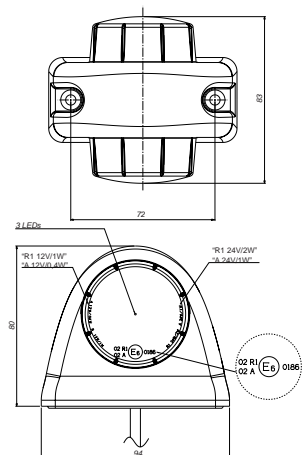



END OUTLINE MARKER LAMP / UMRISSELEUCHTE / GÁLIBO

LIGHTING AND WARNING / BELEUCHTUNG UND MARKIERUNG / ILLUMINACIÓN Y SEÑALIZACIÓN

Cable Kit 5 Pin Connector
Kabel-Satz 5-Poliger Stecker
Kit Cableado Clavija conector 5 pin

Ref	Kg	A	Lot
2597014	0.87	3 m.	1
2597015	1.13	5 m.	1
2597016	1.43	7 m.	1

Cables 5 * 0.5 mm2 | 7-pin plug | 5 pin connectors*2
Cables 5*0.5 mm2 | Clavija 7 polos | Conectores 5 pin*2

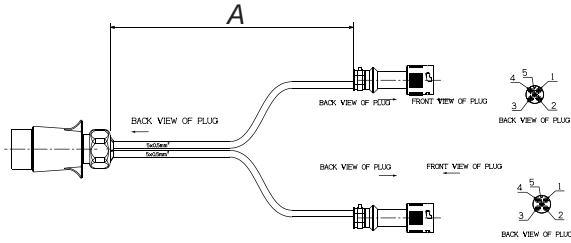

Right(BLACK)		
Pin No	Color	Functions
1	Green	DI.Right
2	Red	Brake
3	N/A	N/A
4	Brown	Tail
5	White	Ground

Left(ORANGE)		
Pin No	Color	Functions
1	Yellow	DI.Left
2	Red	Brake
3	Blue	Fog
4	Black	Tail
5	White	Ground

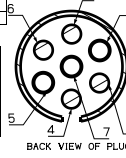
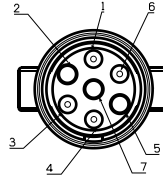

Pin No	Color	Function:
1	Yellow	DI. Left
2	Blue	Fog
3	White	Ground
4	Green	DI. Right
5	Brown	Tail-Right
6	Red	Brake
7	Black	Tail-Left



Cable Kit 7 Pin Connector
Kabel-Satz 7-Poliger Stecker
Kit Cableado conector 7 pins

Ref	Kg	Lot
2597018	0.06	1

Conectors 7 pin | kit includes: 1 AMP connector, 1 cable gland, 6 seals and 6 terminals
Conectores 7 pin | El kit incluye: 1 conector AMP, 1 pasacables, 6 sellos y 6 terminales

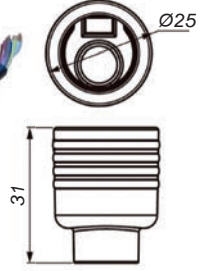

DAF CF 65 (1/2001 - 5/2013) | CF 75 (1/2001 - 5/2013) |
CF 85 (1/2001 - 5/2013) | LF 45 (1/2001 - 6/2006) | LF 55
(1/2001 - 6/2006) | UNIVERSAL | XF 105 (10/2005 -) | XF 95
(1/2002 - 12/2006)

NEW



Ref	Caract.	OE
9723016		1451482
9733016		

DAF CF 65 (1/2001 - 5/2013) | CF 75 (1/2001 - 5/2013) |
CF 85 (1/2001 - 5/2013) | LF 45 (1/2001 - 6/2006) | LF 55
(1/2001 - 6/2006) | UNIVERSAL | XF 105 (10/2005 -) | XF 95
(1/2002 - 12/2006)

NEW



Ref	Caract.	OE
9709016	P21W x4 R10W x2	1401713
9710016	P21W x4 R10W x2	1401731

DAF CF 65 (1/2001 - 5/2013) | CF 75 (1/2001 - 5/2013) |
CF 85 (1/2001 - 5/2013) | LF 45 (1/2001 - 6/2006) | LF 55
(1/2001 - 6/2006) | UNIVERSAL | XF 105 (10/2005 -) | XF 95
(1/2002 - 12/2006)

NEW



Ref	Caract.	OE
9703016	P21W x4 R10W x2	7420862032
9704016	P21W x4 R10W x2	

DAF UNIVERSAL

NEW



Ref	Caract.	OE
9793009		1272653

IVECO EuroCargo I - III (1/2003 - 12/2012) | STRALIS I
(2/2002 - 12/2006)

NEW



Ref	Caract.	OE
9841248	H7 H7 W5W	41221036; 504020193; 504238117
9842248	H7 H7 W5W	41221015; 504020189; 504238093

IVECO EuroCargo I - III (1/2003 - 12/2012)

NEW



Ref	Caract.	OE
9603245	PY 21W	504047573

IVECO DAILY III Caja/Chasis (5/1999 - 4/2006) | UNIVERSAL

NEW



Ref	Caract.
9721008	
9722008	

IVECO EuroCargo I - III (1/2003 - 12/2012)

NEW



Ref	Caract.	OE
9611245	P21W	504107550
9612245	P21W	504133023



CABIN LIGHTING / KABINENBELEUCHTUNG / ILUMINACIÓN CABINA

LIGHTING AND WARNING / BELEUCHTUNG UND MARKIERUNG / ILUMINACIÓN Y SEÑALIZACIÓN

IVECO STRALIS I (2/2002 - 3/2012)

NEW

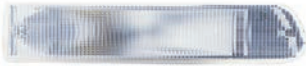

Ref	Caract.	OE
9602248		41221040; 42555022; 93190977

IVECO UNIVERSAL

NEW



Ref	Caract.	OE
9793009		42531584; 93161844

MAN TGA (6/1999 - 12/2008) | UNIVERSAL

NEW



Ref	Caract.	OE
9793009		81252296051

MAN TGA (6/1999 - 12/2008)

NEW



Ref	Caract.	OE
9607009		81252606101

MERCEDES ACTROS (- 12/2003) | ACTROS MP2 / MP3 (10/2002 -) | AXOR (11/2001 - 12/2005) | SK (7/1987 - 9/1996)

NEW



Ref	Caract.	OE
9711013		A0025441290; A0025441390; A0025444790

MERCEDES ACTROS (- 12/2003) | ACTROS MP2 / MP3 (10/2002 -) | ACTROS MP4 / MP5 (7/2011 -) | AXOR 2 (10/2004 - 12/2011)

NEW



Ref	Caract.	OE
9703013		A0005445411

MERCEDES ACTROS MP4 / MP5 (7/2011 -)

NEW



Ref	Caract.	OE
9713013		A0025447390

MERCEDES ACTROS MP4 / MP5 (7/2011 -)

NEW



Ref	Caract.	OE
9702013		A0035440803; A0035441003
9701013		A0035440903; A0035441703

MERCEDES ATEGO (1/1998 - 10/2004) | SPRINTER 2 - t Caja/
Chasis (901, 902) (1/1995 - 5/2006) | SPRINTER 3 - t Caja/
Chasis (903) (2/1995 - 5/2006)

NEW



Ref	Caract.	OE
9797009		A0025441390

MERCEDES ATEGO (1/1998 - 10/2004) | ATEGO 2 (10/2004 - 12/2012)

NEW



Ref	Caract.	OE
9611272		A9738200321
9612272		A9738200421

MITSUBISHI Canter VII (1/2005 - 11/2010) | Canter V (1/2005 - 4/2013)

NEW



Ref	Caract.	OE
9711005		MK580447
9712005		MK580448

NISSAN CABSTAR / ATLAS (7/1992 - 9/2011) | CABSTAR
(9/2006 - 12/2013) | CABSTAR E (10/1998 - 11/2006) | AT-
LEON (9/2000 - 8/2006)

NEW



Ref	Caract.
9723016	
9733016	

MERCEDES ATEGO (1/1998 - 10/2004) | AXOR (11/2001 - 12/2005) | ECONIC (1/1998 -)

NEW



Ref	Caract.	OE
9613272		A9418201021

MITSUBISHI CANTER (8/2012 -) | Canter V (8/2012 - 4/2013) | Fuso (7/2011 -)

NEW



Ref	Caract.	OE
9601026		MK581219
9602026		MK581220

MITSUBISHI Canter VII (1/2005 - 12/2011) | Canter V (1/2005 - 12/2011)

NEW



Ref	Caract.	OE
9605005		MK427117; MK486509
9606005		MK427118; MK486510

NISSAN CABSTAR / ATLAS (7/1992 - 9/2011) | CABSTAR
(9/2006 - 12/2013) | CABSTAR E (10/1998 - 11/2006) | AT-
LEON (9/2000 - 8/2006)

NEW



Ref	Caract.
9709016	
9710016	

LIGHTING AND WARNING / BELEUCHTUNG UND MARKIERUNG / ILUMINACIÓN Y SEÑALIZACIÓN



CABIN LIGHTING / KABINENBELEUCHTUNG / ILUMINACIÓN CABINA

LIGHTING AND WARNING / BELEUCHTUNG UND MARKIERUNG / ILUMINACIÓN Y SEÑALIZACIÓN

NISSAN CABSTAR / ATLAS (7/1992 - 9/2011) | CABSTAR (9/2006 - 12/2013) | CABSTAR E (10/1998 - 11/2006) | AT-LEON (9/2000 - 8/2006)

NEW



Ref	Caract.										
9703016											
9704016											

NISSAN CABSTAR (9/2006 - 12/2013)

NEW



Ref	Caract.			
9606016				

RENAULT MASCOTT Caja/Chasis (1/1999 - 12/2010) (5/2004 - 12/2013) / Furgón (1/1999 - 10/2010) / Volquete (1/2000 - 6/2004) | Maxity (3/2007 -) | Midliner (10/1982 - 1/2000) | Midlum (1/2000 -) | Premium (4/1996 - 12/2005)

NEW



Ref	Caract.										
9709016											
9710016											

RENAULT Midliner (10/1982 - 1/2000) | Midlum (1/2000 -) | Premium (4/1996 - 12/2005)

NEW



Ref	Caract.				OE
9601016					50.01.834560
9602016					50.01.834559

NISSAN CABSTAR (9/2006 - 12/2013)

NEW



Ref	Caract.					
9861016						
9862016						

RENAULT MASCOTT Caja/Chasis (1/1999 - 12/2010) (5/2004 - 12/2013) / Furgón (1/1999 - 10/2010) / Volquete (1/2000 - 6/2004) | Maxity (3/2007 -) | Midliner (10/1982 - 1/2000) | Midlum (1/2000 -) | Premium (4/1996 - 12/2005)

NEW



Ref	Caract.			
9723016				
9733016				

RENAULT MASCOTT Caja/Chasis (1/1999 - 12/2010) (5/2004 - 12/2013) / Furgón (1/1999 - 10/2010) / Volquete (1/2000 - 6/2004) | Maxity (3/2007 -) | Midliner (10/1982 - 1/2000) | Midlum (1/2000 -) | Premium (4/1996 - 12/2005)

NEW



Ref	Caract.										
9703016											
9704016											

RENAULT Midliner (10/1982 - 1/2000) | Midlum (1/2000 -) | Premium (4/1996 - 12/2005) | Premium 2 (10/2005 - 4/2013)

NEW



Ref	Caract.					OE
9607016						50.01.834565

RENAULT Premium (4/1996 -) | Premium 2 (10/2005 - 4/2013) | UNIVERSAL

NEW



Ref	Caract.	OE
9793009		50.00.296594; 50.01.847588

SCANIA 2 - series (- 3/1998) | 3 - series (5/1987 - 12/1998) / bus (1/1988 - 12/1997)

NEW



Ref	Caract.	OE
9793009		1272653

SCANIA 4 - series (5/1995 - 3/2005) | UNIVERSAL (- 12/2007)

NEW



Ref	Caract.	OE
9793003		1380819

SCANIA 4 - series (5/1995 - 3/2005)

NEW



Ref	Caract.	OE
9601101	P21W x2 R5W x2	1349783; 1385410; 1524093
9602101	P21W x2 R5W x2	1337250; 1349784; 1387155

UNIVERSAL

NEW



Ref	Caract.
9793009	

UNIVERSAL

NEW



Ref	Caract.
9723010	

UNIVERSAL

NEW



Ref	Caract.
9603013	

VOLVO F16 (8/1993 - 12/2002) | FH12 (8/1993 - 12/2002) | FM10 (4/1999 - 9/2003) | FM12 (8/1998 - 12/2002) | FM7 (8/1998 - 12/2001)

NEW



Ref	Caract.	OE
9793009		1272653; 1350343; 3981782



CABIN LIGHTING / KABINENBELEUCHTUNG / ILUMINACIÓN CABINA

LIGHTING AND WARNING / BELEUCHTUNG UND MARKIERUNG / ILUMINACIÓN Y SEÑALIZACIÓN

VOLVO F16 (9/2001 - 12/2007) | FH12 (9/2001 - 12/2007) |
FH16 (1/2003 - 12/2007) | FM (9/2005 - 12/2007) | FM12
(9/2001 - 11/2008) | FM9 (12/2001 - 9/2005)

NEW







Ref	Caract.	OE
9793003	 	1380819; 3981782

VOLVO F16 (9/2007 - 12/2012) | FH16 (9/2007 - 12/2012)

NEW

















Ref	Caract.	OE
9613285	    	20398660; 20789440

VOLVO FE (5/2006 - 12/2012) | FL II (5/2006 - 12/2012)

NEW



Ref	Caract.	OE
9703016	      	20769781; 20769783; 7420862035
9704016	      	20769782; 20769784



FAROS DE TRABAJO
WORK LAMP

LIGHTING AND WARNING / BELEUCHTUNG UND MARKIERUNG / ILLUMINACIÓN Y SEÑALIZACIÓN

Work Lamp LED 70x70
LED-Arbeitscheinwerfer 70x70
Faro de Trabajo LED 70x70

Ref	Kg	V	Emark	Lot
2596021	0.17	12/36v	E4	1

3 LEDs | RAW Lumen 720 | Effective Lumen 464 | HV CD 1100 | Connector: 280 mm. cable | IP69K | Temperature -30°C~50°C
3 LEDs | RAW Lumen 720 | Effective Lumen 464 | HV CD 1100 | Connector: 280 mm. cable | IP69K | Temperature -30°C~50°C
EMC R10

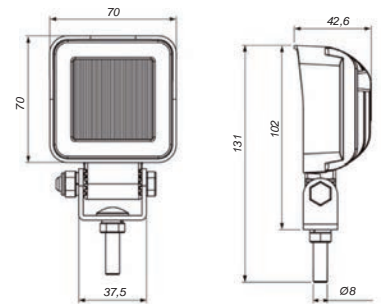

Work Lamp LED 2 in 1
LED-Arbeitscheinwerfer 2 in 1
Faro de Trabajo LED 2 en 1

NEW

Ref	Kg	V	Emark	Function Funciones	Lot
2596019	0.45	12/36v	E4		1

2 in 1: Reverse and Work lamp | RAW Lumen 1440 | Effective Lumen 1028 | HV CD 900 | Connector: 280 mm. cable | IP69K | Temperature -30°C~50°C
2 en 1: Marcha atrás y luz de trabajo | RAW Lumen 1440 | Effective Lumen 1028 | HV CD 900 | Connector: 280 mm. cable | IP69K | Temperatura -30°C~50°C
EMC R10 | ECE R23

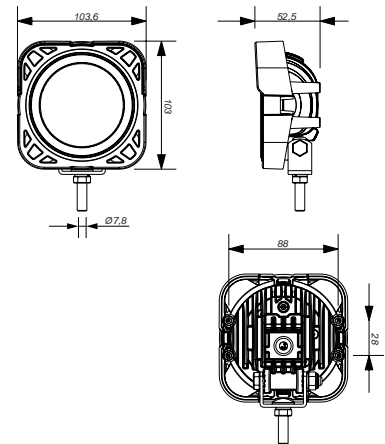

Work Lamp LED 125x115
LED-Arbeitscheinwerfer 125x115
Faro de Trabajo LED 125x115

Ref	Kg	V	Emark	Lot
2596020	0.67	12/36v	E4	1

9 SMD high power LEDs | RAW Lumen 2160 | Effective Lumen 1492 | HV CD 4100 | Connector: 280 mm. cable | IP69K | Temperature -30°C~50°C
9 SMD high power LEDs | RAW Lumen 2160 | Effective Lumen 1492 | HV CD 4100 | Connector: 280 mm. cable | IP69K | Temperature -30°C~50°C
ECE | EMC R10

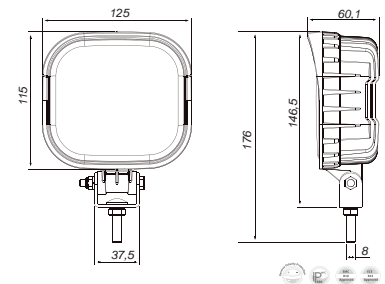

WORK LAMP AND EMERGENCY / SCHEINWERFER UND NOTLICHT / FAROS DE TRABAJO Y EMERGENCIA

LIGHTING AND WARNING / BELEUCHTUNG UND MARKIERUNG / ILLUMINACIÓN Y SEÑALIZACIÓN

Work Lamp LED 70x70x42
LED-Arbeitsscheinwerfer 70x70x42
Faro de Trabajo LED 70x70x42

Ref	Kg	V	Emark	Lot
2596026	0.29	12/36v		1

3 SMD LEDs | Polycarbonate lenses | Thermal conductive plastic housing | 720 Lumen | HV CD 1200 | Connector: 300 mm. cable | IP67 | High resistance co
3 SMD LEDs | Lentes Polycarbonato | Carcasa plástico conductor térmico | 720 Lumen | HV CD 1200 | Conector: 300 mm. cable | IP67 | Alta resistencia corr
EMC R10 | ECER23

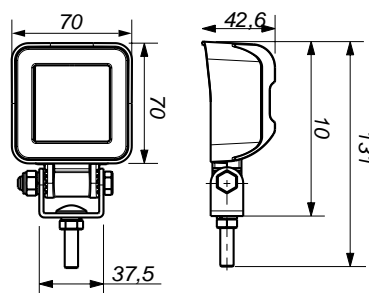

Work Lamp LED 99x99x54
LED-Arbeitsscheinwerfer 99x99x54
Faro de Trabajo LED 99x99x54

Ref	Kg	V	Emark	Lot
2596027	0.44	12/36v		1

9 SMD high power LEDs | Lens: PC | Housing: alu | Bracket: Inox | Raw Lumen: 2160 | Effective Lumen: 1490 | HV CD 1900 | 300mm cable | IP67 | -30°C-50°C
9 SMD high power LEDs | Lente: PC | Carcasa: alu | Bracket: Inox | Raw Lumen: 2160 | Effective Lumen: 1490 | HV CD 1900 | 300 mm. cable | IP67 | -30°C-50°C
EMC R10

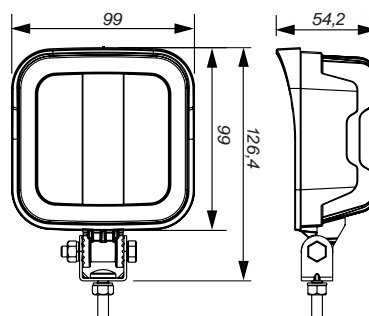

Work Lamp LED 105x124
LED-Arbeitsscheinwerfer 105x124
Faro de Trabajo LED 105x124

Ref	Kg	V	Emark	Lot
2596022	0.52	12/36v		1

6 SMD high power LEDs | RAW Lumen 1440 | Effective Lumen 1036 | HV CD 3450 | Connector: 280mm cable | IP69K | Temperature -30°C-50°C
6 SMD high power LEDs | RAW Lumen 1440 | Effective Lumen 1036 | HV CD 3450 | Connector: 280mm cable | IP69K | Temperatura -30°C-50°C
EMC R10 | ECER23

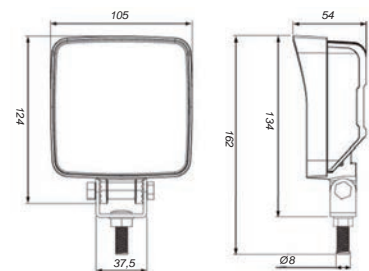

Work Lamp LED Ø115
LED-Arbeitsscheinwerfer Ø115
Faro de Trabajo LED Ø115

Ref	Kg	Ø	V	Emark	Lot
2596025	0.62	115	9/36v		1

8 LEDs | RAW Lumen 1920 | Effective Lumen 1295 | HV CD 3600 | Connector: 280 mm. cable | IP69K | Temperature -30°C ~ 50°C
8 LEDs | RAW Lumen 1920 | Effective Lumen 1295 | HV CD 3600 | Conector: 280 mm. cable | IP69K | Temperature -30°C~50°C
EMC R10

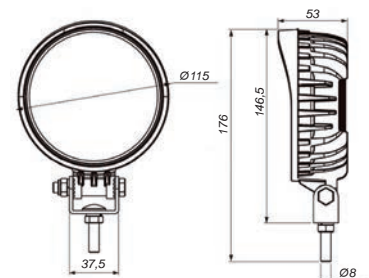



LIGHTING AND WARNING / BELEUCHTUNG UND MARKIERUNG / ILLUMINACIÓN Y SEÑALIZACIÓN

LED Strobe Light Amber 10-30V w/Cable
Stroboskoplicht LED 10-30V mit Kabel
Luz de Emergencia Estroboscópico LED 10-30V c/Cable

NEW

Ref	Kg	V	E-mark	Lot
2596200	0.08	10/30v	E ₆	1

LED | IP67 | with Cable | Multiple Flash Patterns and Sync Capability | Sync up to 8 units
LED | IP67 | C/CABLE | Múltiples patrones de destello y capacidad de sincronización |
Sincroniza hasta 8 unidades
EMC R10 | ECE R65 | SAE DOT

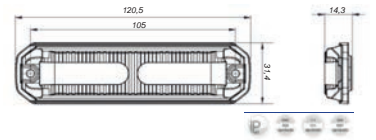
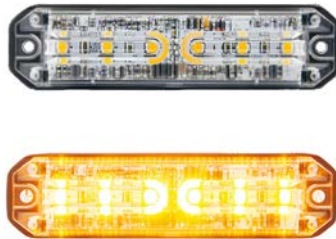

Amber Revolving LED Beacon Superficial Assembly
LED-Rundumleuchte Gelb Außenmontage
Rotativo LED Ámbar Montaje Superficial

Ref	Kg	Ø	V	E-mark	Lot
2596032	0.56	161	12/24v	E ₆	1

12 Amber LEDs | Polycarbonate lenses | Connector: 340 mm. cable
12 LEDs Ámbar | Lentes Polycarbonato | Conector: 340 mm. cable
ECE R65 | ECE R10

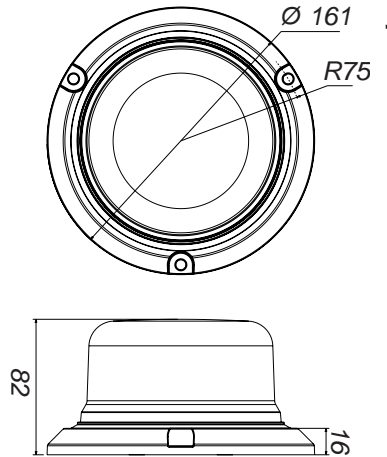

Amber revolving LED Beacon Pole Assembly
LED-Rundumleuchte Gelb zum Aufstecken auf Rohr
Rotativo LED Ámbar Montaje en Poste

Ref	Kg	Ø	V	Lot
2596034	0.4	122	12/36v	1

12 Amber LEDs | Polycarbonate lenses | Connector: 340 mm. cable
12 LEDs Ámbar | Lentes Polycarbonato | Conector: 340 mm. cable
ECE R65 | ECE R10

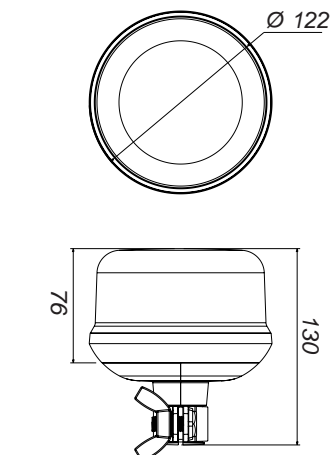



WORK LAMP AND EMERGENCY / SCHEINWERFER UND NOTLICHT / FAROS DE TRABAJO Y EMERGENCIA

LIGHTING AND WARNING / BELEUCHTUNG UND MARKIERUNG / ILLUMINACIÓN Y SEÑALIZACIÓN

Magnetic Base LED Beacon with lighter socket
LED-Rundumleuchte Gelb Magnetfuß mit Stecker für Zigarettenanz.
Rotativo LED Base Magnética c/enchufe mechero

Ref	Kg	Ø	V	Lot
2596031	0.78	140	12/24v	1

Lighter Socket | IP65 | Fixation: Magnetic
Toma de mechero | IP65 | Fijación: Magnética
ECE R65

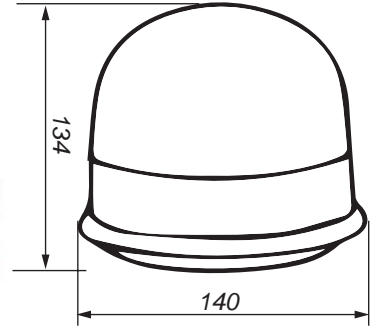

Magnetic Base LED Flat Beacon with lighter socket
LED-Rundumleuchte Gelb Magnetfuß mit Stecker für Zigarettenanz.
Rotativo LED Plano Base Magnética c/enchufe mechero

Ref	Kg	Ø	V	E-mark	Lot
2596033	0.6	140	12/24v	E9	1

Lighter Socket | IP66 | Fixation: Magnetic | h=70
Toma de mechero | IP66 | Fijación: Magnética | h=70
ECE R65 | ECE R10

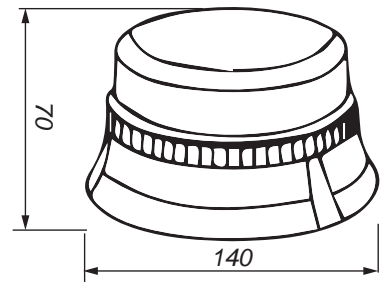



VISION TRASERA
REAR VIEW

LIGHTING AND WARNING / BELEUCHTUNG UND MARKIERUNG / ILLUMINACIÓN Y SEÑALIZACIÓN

Rear View Camera Set + Cable 15m.
Rückfahrkamera Set + Kabel 15m.
Kit Cámara Visión Trasera + Cable 15m.

Ref	Kg	Lot
2597050	2.2	1

Screen 7" (178 mm.) | 2 entries AV | Temperature: from -20 °C to +65 °C | IP68
Pantalla 7" (178 mm.) | 2 entradas AV | Temperatura: De -20 °C hasta +65 °C | IP69K



Rear View Camera for 2597050
Rückfahrkamera pour 2597050
Cámara Secundaria Visión Trasera para 2597050

Ref	Kg	Mat	V	E-mark	Article	Lot
2597048	0.36		12V		Stainless steel visor Visera en acero inoxidable	1

NTSC&PAL | Viewing Angle: 120° | Minimum Illumination: 0 Lux-F1,2 |
Temperature: from -20 °C to +75 °C | Sealing Rate: IP69K | Impact Rating: 10G
NTSC&PAL | Angulo Visión 120° | Iluminación min. 0 Lux-F1,2 |
Temperatura: De -20 °C hasta +75 °C | Estanqueidad IP69K | Resistencia vibraciones 10G



Rear View Camera Cable Set (20m.) for 2597048
Kabel Set für Rückfahrkamera (20m.) für 2597048
Kit Cables Cámara (20m.) para 2597048

Ref	Kg	Lot
2597046	0.68	1





REAR VIEW CAMERA / RÜCKFAHRKAMERA / VISION TRASERA

LIGHTING AND WARNING / BELEUCHTUNG UND MARKIERUNG / ILLUMINACION Y SEÑALIZACION

Rear View Camera Set + Cable 20m.
Rückfahrkamera Set + Kabel 20m.
Kit Cámara Visión Trasera + Cable 20m.

Ref	Kg	Lot
2597054	2	1

Screen 7" LCD | 16:9 | 2 Entries 4 pin | 1024xRGBx600 | Video: 720P@960P@1080P HD 25/30fps PAL/NTSC | 120° | -20 °C +75 °C | IP68 | 10G | 300cd/m2
Monitor 7" LCD | 16:9 | Entradas 4 pin: 2 | 1024xRGBx600 | Video: 720P@960P@1080P HD 25/30fps PAL/NTSC | 120° | -20 °C +75 °C | IP68 | 10G | 300cd/m2



Rear View Camera for 2597054
Rückfahrkamera für 2597054
Cámara Secundaria Visión Trasera para 2597054

Ref	Kg	Article	Lot
2597056	0.4		1

Viewing Angle: 120° | Minimum Illumination: 0 Lux-F1,2 | Temperature: from -20 °C to +75 °C | Sealing Rate: IP68 | Impact Rating: 10G
Angulo de Visión 120° | Iluminación mín. 0 Lux-F1,2 | Temperatura: De -20 °C hasta +75 °C | Estanqueidad IP68 | Resistencia vibraciones 10G



Rear View Camera Cable Set (20m.) for 2597056
Kabel Set für Rückfahrkamera (20m.) für 2597056
Kit Cables Cámara marcha atrás 4-pin (20m.) para 2597056

Ref	Kg	Lot
2597072	0.75	1

Connector:water,proof,with lock,arecraft grade| OD:M12| 4pin| Cores wire:power,video,audio,earthing,cotton| Conductor:copper|Insolation: PU|Jacket: PVC
OD: M12 | 4 pin | núcleo cable: power, video, audio, earthing, cotton | Material Conductor: cobre | Material Aislante: PU | Cubierta: PVC



Standard Reverse Alarm 12-80V
Rückfahralarm 12-80V
Avisador de marcha atrás 12-80V

Ref	Kg	Emark	Lot
2597052	0.8		1

Size Level: 100x72x44 | Sound Level: 97DB+/-5DB | IP67
Medidas: 100x72x44 | Nivel sonido: 97DB+/-5DB | IP67



DAF LF 45 (1/2001 - 4/2006) | LF 55 (1/2001 - 4/2006)

NEW



Ref	Caract.	OE
9401141		1404 871; 1405295; 1805 712
9403141		1404871; 1405295; 1805712

DAF LF 45 (1/2001 - 4/2006) | LF 55 (1/2001 - 4/2006)

NEW



Ref	Caract.	OE
9477282		1403 786; 1403 838; 1405601; 1620023; 1805714

DAF LF 45 (1/2001 - 4/2006) | LF 55 (1/2001 - 4/2006)

NEW



Ref	Caract.	OE
9423141		1404868; 1404870; 1405350; 1796324

IVECO EuroCargo I - III (1/1991 - 12/2000)

NEW



Ref	Caract.	OE
9475246		98424107; 98424108; 99457908

IVECO EuroCargo I - III (1/1991 - 12/2000) | MK (1/1983 - 12/1991) | P/PA (12/1979 - 12/1993) | TurboStar (7/1984 - 12/1993) | TurboTech (1/1990 - 12/1992)

NEW



Ref	Caract.	OE
9451246		2997216; 2997312; 2997313; 42209232; 42209233; 42345780; 42345783; 42350421; 98424102; 99457905

IVECO EuroCargo I - III (5/2006 - 9/2015) | STRALIS I (1/2007 - 12/2012) | STRALIS II (9/2012 -) | TRAKKER I (3/2006 - 12/2012) | Tector (12/2008 - 4/2012)

NEW



Ref	Caract.	OE
7474244		504197878

IVECO UNIVERSAL

NEW



Ref	Caract.	OE
9470235		98424107; 98424108

IVECO MK (1/1983 - 12/1991)

NEW



Ref	Caract.	OE
9470151		86003144



MIRRORS / SPIEGEL / ESPEJOS

LIGHTING AND WARNING / BELEUCHTUNG UND MARKIERUNG / ILUMINACIÓN Y SEÑALIZACIÓN

MAN F90 (7/1986 - 9/1994) | M90 (8/1988 - 9/1994)

NEW



Ref	Caract.	OE
9401261		81637306220; 81637306233; 81637306239; 81637306245; 83637307500

MAN F90 (7/1986 - 9/1994) | M90 (8/1988 - 9/1994)

NEW



Ref	Caract.	OE
9421261		81637306222; 81637306223; 81637306235; 81637306236; 81637306242; 81637306248; 81637306299; 81637306324

MAN G (10/1979 - 8/1988) | UNIVERSAL

NEW



Ref	Caract.	OE
9401286		81637306127; 81637306167

MAN LION'S CITY (- 10/2009) | NG (8/1992 - 12/2014) | SG (7/1976 - 8/2008) | SL (5/1980 - 4/1987)

NEW



Ref	Caract.	OE
9470151		81637306197

MAN UNIVERSAL

NEW



Ref	Caract.	OE
9470260		81637306147

MERCEDES ACTROS (- 10/2003) / MP2 / MP3 (10/2002 -) | ATEGO (1/1998 - 10/2004) | AXOR (1/2002 - 10/2004) | ECONIC (1/1998 -)

NEW



Ref	Caract.	OE
7423272		A0018112133; A0018116033

MERCEDES ACTROS (- 12/2003) / MP2 / MP3 (10/2002 -) | ECONIC (1/1998 -)

NEW



Ref	Caract.	OE
7403273		A0018112033; A0028110433

MERCEDES ACTROS (- 12/2003) / MP2 / MP3 (10/2002 -) | ECONIC (1/1998 -)

NEW



Ref	Caract.	OE
9403273		A0008109516; A0018109016

MERCEDES ACTROS (- 12/2003) / MP2 / MP3 (10/2002 -)
 | ATEGO (1/1998 - 10/2004) | AXOR (11/2001 - 12/2005) |
 ECONIC (1/1998 -)

NEW



Ref	Caract.	OE
9423272		A0008109616; A0018109216

MERCEDES ATEGO (1/1998 - 10/2004) | AXOR (11/2001 - 12/2005)

NEW



Ref	Caract.	OE
9401272		A0008100279; A0008110222

MERCEDES ATEGO 2 (10/2004 - 5/2009) | AXOR 2 (10/2004 - 5/2009)

NEW



Ref	Caract.	OE
9403272		A0008101679; A0008102479; A0028114633
9406272		A0008101679; A0008102479

MERCEDES LK/LN2 (1/1984 - 12/2011) | LP (1/1981 - 12/1990)

NEW



Ref	Caract.	OE
9401270		A0008100416; A3148101316; A6738103916

MERCEDES ACTROS MP2 / MP3 (6/2008 -) | ATEGO 2 (10/2004 - 12/2014) | AXOR 2 (10/2004 - 12/2011)

NEW



Ref	Caract.	OE
9426274		A0028103716; A9408102616; A9418100816

MERCEDES ATEGO (1/1998 - 10/2004) | AXOR (1/2002 - 10/2004)

NEW



Ref	Caract.	OE
7403272		A0008117333; A0018113433; A0018117433

MERCEDES ATEGO 2 (6/2009 - 12/2014) | AXOR 2 (6/2009 - 12/2011)

NEW



Ref	Caract.	OE
7433272		A0028114633

MERCEDES ATEGO 2 (6/2009 - 12/2014) | AXOR 2 (6/2009 - 12/2011)

NEW



Ref	Caract.	OE
7439272		A0028114733



MIRRORS / SPIEGEL / ESPEJOS

LIGHTING AND WARNING / BELEUCHTUNG UND MARKIERUNG / ILUMINACIÓN Y SEÑALIZACIÓN

MERCEDES LP (9/1963 - 12/1990) | NG (8/1973 - 12/1986) | O 303 (10/1974 - 9/1992) | O 404 (1/1991 - 12/1999) | O 405 (1/1984 -) | T2/L (1/1959 - 12/1995) | UNIMOG (1/1955 - 3/1990)

NEW



Ref	Caract.	OE
9470151	 1800 ABS PP	67381004016; A0008102716; A0008106216; A0008111233; A2818107116; A3148102616; A3818102516; A3818107116; A6638100816; A67381008

NISSAN CABSTAR | ATLAS (7/1992 - 9/2011) / CABSTAR (9/2006 - 12/2013) / CABSTAR E (10/1998 - 11/2006)

NEW



Ref	Caract.
7401544	 1200

NISSAN CABSTAR | ATLAS (7/1992 - 9/2011) / CABSTAR (9/2006 - 12/2013) / CABSTAR E (10/1998 - 11/2006)

NEW



Ref	Caract.
9401544	 1200 ABS
9403544	 1200 ABS

NISSAN Kerax (6/1997 - 12/2006) | Midliner (10/1982 - 1/2000) | Midlum (1/2000 -) | Premium (4/1996 - 12/2005)

NEW



Ref	Caract.	OE
9423141	 1800 300 PP	74.21.276373

MITSUBISHI Canter VII (1/2005 - 11/2010) | Canter V (1/2005 - 4/2013)

NEW



Ref	Caract.	OE
7403005	 1200	MK580133

MITSUBISHI Canter VII (1/2005 - 11/2010) | Canter V (1/2005 - 4/2013)

NEW



Ref	Caract.
9401005	 1350 ABS

NISSAN ATLEON (9/2000 - 6/2008)

NEW



Ref	Caract.	OE
7401545	 1200 	96366-9X025

NISSAN Midliner (10/1982 - 1/2000) | Midlum (1/2000 -) | Premium (4/1996 - 12/2005)

NEW



Ref	Caract.	OE
9477282	 1800 	50.01.853677; 50.01.856290

NISSAN NEW GENERATION

NEW



Ref	Caract.	OE
9401141		50.01.853675; 50.01.856292; 50.01.833026;
9403141		50.01.844006; 50.01.8536375; 50.01.856292

SCANIA 4 - series (5/1995 - 8/2008) | P,G,R,T - series (3/2004 - 10/2005)

NEW



Ref	Caract.	OE
7403001		1346377; 1442705; 1442706; 1745369; 1749684; 1765985

UNIVERSAL

NEW

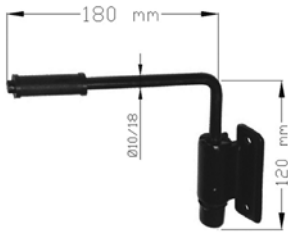

Ref	Caract.
9403011	

UNIVERSAL

NEW



Ref	Caract.
9470500	

UNIVERSAL

NEW



Ref	Caract.
9470200	

UNIVERSAL

NEW



Ref	Caract.
9470205	

UNIVERSAL

NEW



Ref	Caract.
9470210	

UNIVERSAL

NEW



Ref	Caract.
9401286	



MIRRORS / SPIEGEL / ESPEJOS

LIGHTING AND WARNING / BELEUCHTUNG UND MARKIERUNG / ILUMINACIÓN Y SEÑALIZACIÓN

VOLVO FL4 (2/1986 - 10/1989) | FL6 (9/1985 - 8/2000)

NEW



Ref	Caract.						OE
9470151							6793879; 67938795

UNIVERSAL

NEW



Ref	Caract.					
9470260						

UNIVERSAL

NEW



Ref	Caract.							
9477282								

UNIVERSAL

NEW



Ref	Caract.					
9470215						

UNIVERSAL

NEW



Ref	Caract.					
9423141						

VOLVO F10 (1/1976 - 12/1995) | F12 (1/1976 - 12/1995)

NEW



Ref	Caract.					
9470260						

UNIVERSAL

NEW



Ref	Caract.					
9470235						

UNIVERSAL

NEW



Ref	Caract.					
9421261						

UNIVERSAL

NEW



Ref	Caract.					
9451246						

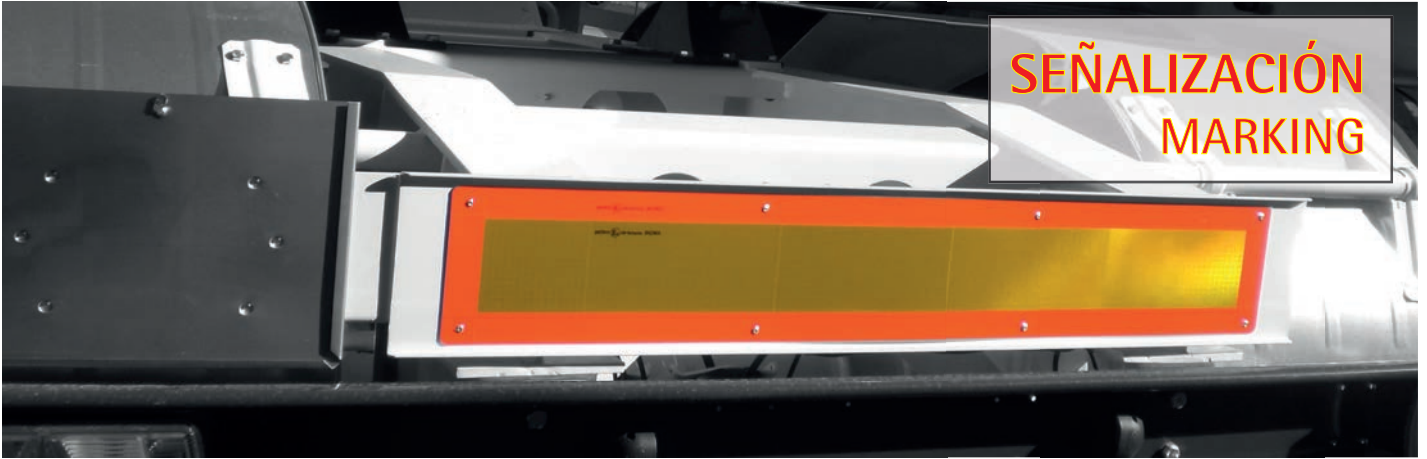

2 Kit Trailer Sign Approved (ECE/70-01)
 2er Set LKW-Warntafel Homol. (ECE/70-01)
 Kit 2 Placas Remolque Homologada (ECE/70-01)

Ref	Kg	Mat	Thickn. Espesor	Emark	Article	Lot
7201014	0.66		1		RF	1

Aluminum 1 mm. plates greater or equal to 3,500 kg Trailer |
 Prismatic yellow film with red printed
 Placas de aluminio 1 mm espesor para remolque mayor o igual de 3.500 Kg. |
 Film amarillo prismático con estampado rojo
 ECE 70-01

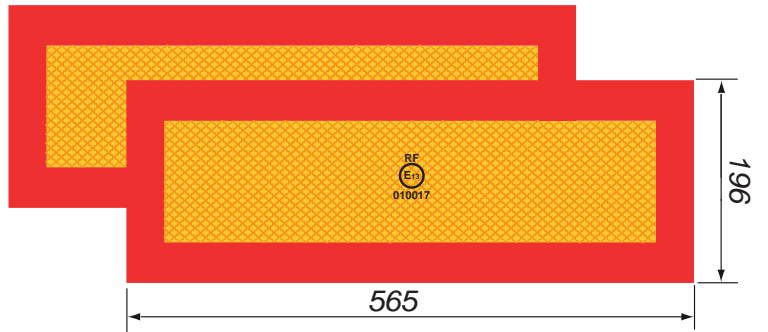

Trailer Sign Approved (ECE/70-01)
 LKW-Warntafel Homol. (ECE/70-01)
 Placa Remolque Homologada (ECE/70-01)

Ref	Kg	Mat	Thickn. Espesor	Emark	Article	Lot
7201024	0.66		1		RF	1

Aluminum 1 mm. plates greater or equal to 3,500 kg Trailer |
 Prismatic yellow film with red printed
 Placas de aluminio 1 mm espesor para remolque mayor o igual de 3.500 Kg. |
 Film amarillo prismático con estampado rojo
 ECE 70-01

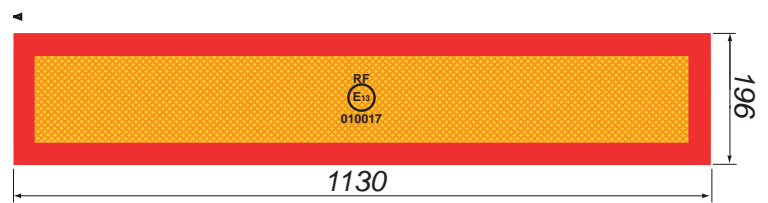

2 Kit Trailer Sign Approved (ECE/70-01)
 2er Set LKW-Warntafel Homol. (ECE/70-01)
 Placa Homologada (ECE/70-01) Kit 2 uds

Ref	Kg	Mat	Thickn. Espesor	Emark	Article	Lot
7201016	0.45		1		RR	1

Aluminum 1 mm. plates greater or equal to 3,500 kg vehicle |
 Prismatic yellow film with red printed
 Placas de aluminio 1 mm espesor para vehiculo mayor o igual de 3.500 Kg. |
 Film amarillo prismático con estampado rojo
 ECE 70-01

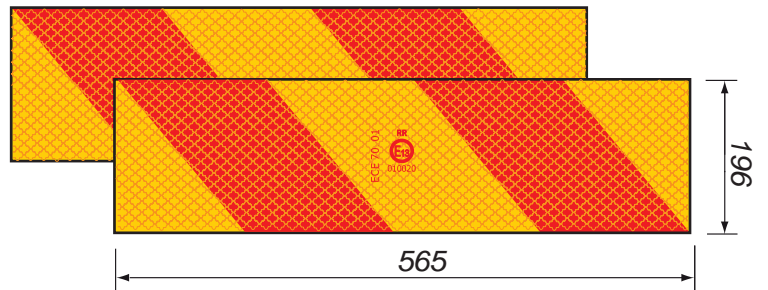

Trailer Sign Approved (ECE/70-01)
 LKW-Warntafel Homol. (ECE/70-01)
 Placa Homologada (ECE/70-01)

Ref	Kg	Mat	Thickn. Espesor	Emark	Article	Lot
7201023	0.5		1		RF	1

Aluminum 1 mm. plates greater or equal to 3,500 kg vehicle
 Placas de aluminio 1 mm espesor para vehiculo mayor o igual de 3.500 Kg.
 ECE 70-01

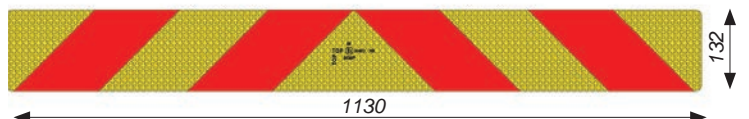



MARKING / MARKIERUNG / SEÑALIZACIÓN

LIGHTING AND WARNING / BELEUCHTUNG UND MARKIERUNG / ILLUMINACIÓN Y SEÑALIZACIÓN

Adhesive 2 Kit Trailer Sign, Approved (ECE/70-01)
2er Set Selbstklebend LKW-Warntafel Homol. (ECE/70-01)
Kit 2 Placas Remolque Adhesiva Homologada (ECE/70-01)

Ref	Kg	Emark	Article	Lot
7201013	0.12		RF	1

Self-adhesive plates greater or equal to 3,500 kg Trailer
Placas auto-adhesivas para remolque mayor o igual de 3.500 Kg.
ECE 70-01

NEW

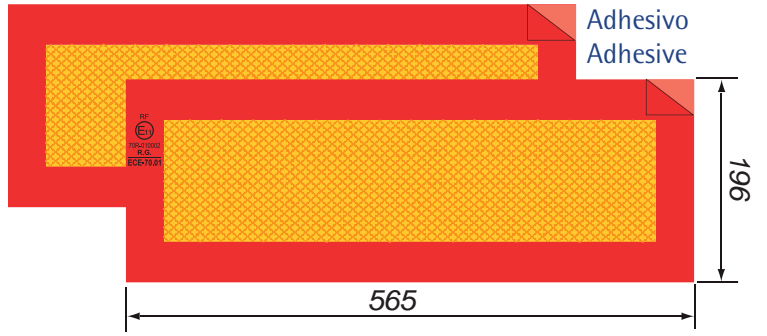

Adhesive Trailer Sign Approved (ECE/70-01)
Selbstklebend Platte LKW-Warntafel Homol. (ECE/70-01)
Placa Remolque Adhesiva Homologada (ECE/70-01)

Ref	Kg	Emark	Article	Lot
7201026	0.12		RR	1

Self-adhesive plates greater or equal to 3,500 kg Trailer
Placas auto-adhesivas para remolque mayor o igual de 3.500 Kg.
ECE 70-01

NEW

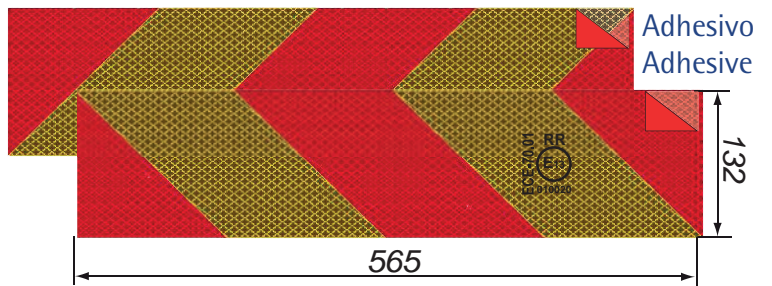

Adhesive Trailer Sign Approved (ECE/70-01)
Selbstklebend Platte LKW-Warntafel Homol. (ECE/70-01)
Placa Remolque Adhesiva Homologada (ECE/70-01)

Ref	Kg	Emark	Article	Lot
7201025	0.1		RF	1

Self-adhesive plate greater or equal to 3,500 kg Trailer
Placas auto-adhesivas para remolque mayor o igual de 3.500 Kg.
ECE 70-01

NEW

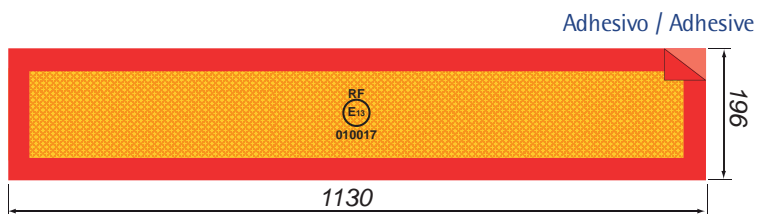

Plate Dangerous Goods 400x300
 Gefahrgut-Tafel klappbar 400x300
 Placa Mercancía Peligrosa V11 400x300 Plegado Horizontal

Ref	Kg	Mat	Thickn. Espesor	Article	Lot
7201032	0.36		1	Horizontal Folding Plegado Horizontal	1

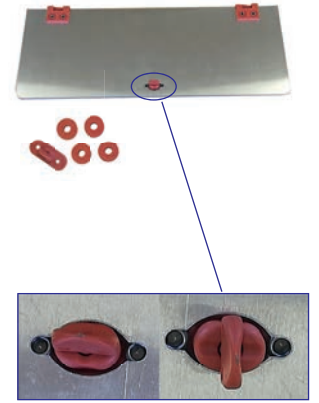
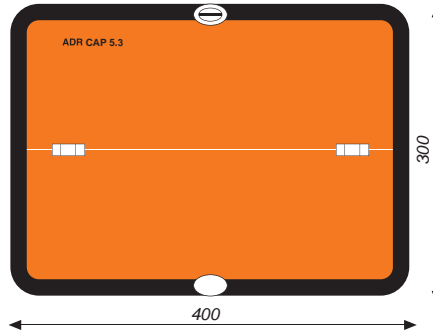
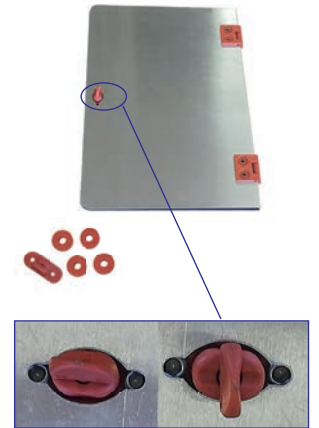
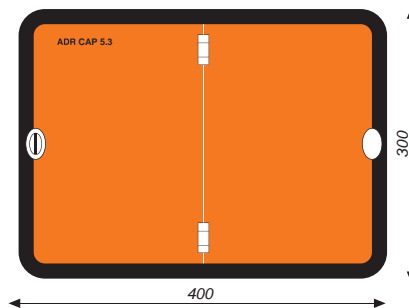

Plate Dangerous Goods 400x300 Vertical
 Gefahrgut-Tafel klappbar 400x300 Vertikal
 Placa Mercancía Peligrosa V11 400x300 Plegado Vertical

Ref	Kg	Mat	Thickn. Espesor	Article	Lot
7201034	0.36		1	Vertical Folding Plegado Vertical	1



ADR Plate Black-White 300X300, Aluminium
 Tafel ADR Schwarz-Weiss 300X300, Aluminium
 Placa Señalización ADR 300x300 Aluminio

Ref	Kg	Mat	Thickn. Espesor	Lot
7201036	0.27		1	1

NEW

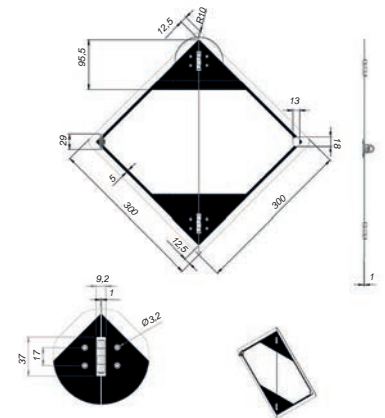

Oversize Load Signal V20 500x500
 LKW-Warntafel Übergrosse Ladung V20 500x500
 Placa Carga Sobresaliente V20 500x500

Ref	Kg	Mat	Thickn. Espesor	Lot
7201040	0.75		1.4	1

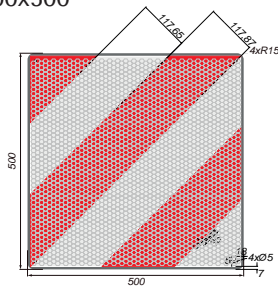

Adhesive Speed Limit Signal French Type Ø200
 Geschwindigkeitsbegrenzungssignal, französischer Typ Ø200
 Señal de Velocidad Adhesiva Tipo Francés Ø200.

NEW

Ref	Kg	Mat	Article	Lot
7201027	0.008			10
7201029	0.008			10

Adhesivo / Adhesive



LIGHTING AND WARNING / BELEUCHTUNG UND MARKIERUNG / ILUMINACIÓN Y SEÑALIZACIÓN



MARKING / MARKIERUNG / SEÑALIZACIÓN

LIGHTING AND WARNING / BELEUCHTUNG UND MARKIERUNG / ILLUMINACIÓN Y SEÑALIZACIÓN

Plate Holder 300x300 with Security Catch
Warntafelhalter 300x300 mit Sicherungsbügel
Soporte Placa Acero 300x300 con pletinas de Seguridad

NEW

Ref	Kg	Mat	Sup/Finish Acabado	Thickn. Espesor	Lot
7201053	0.5	STEEL	Galv	0.6	1
7201056	0.5	INOX		0.6	1

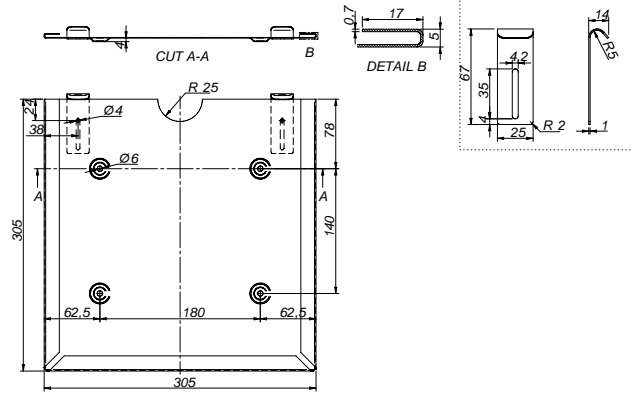
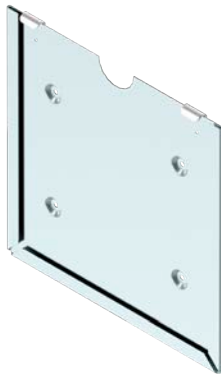
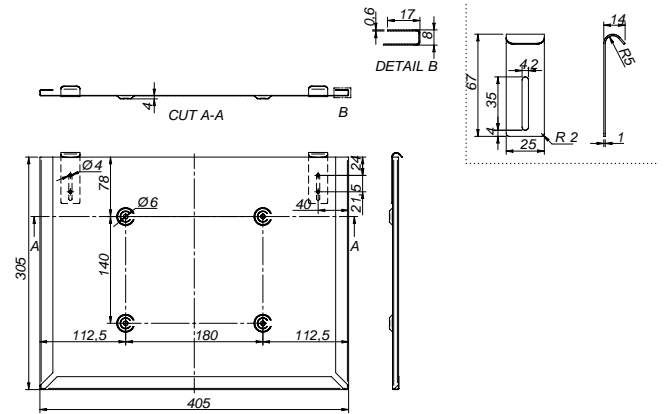

Plate Holder 400x300 with Security Catch
Warntafelhalter 400x300 mit Sicherungsbügel
Soporte Placa Acero 400x300 con pletinas de Seguridad

NEW

Ref	Kg	Mat	Sup/Finish Acabado	Thickn. Espesor	Lot
7201055	0.65	STEEL	Galv	0.6	1
7201059	0.65	INOX		0.6	1



Aluminium Plate Holder 300x300 with Security Catch
Aluminium Warntafelhalter 300x300 mit Sicherungsbügel
Soporte Placa Aluminio 300x300 con pletinas de Seguridad

NEW

Ref	Kg	Mat	Lot
7201050	0.36		1

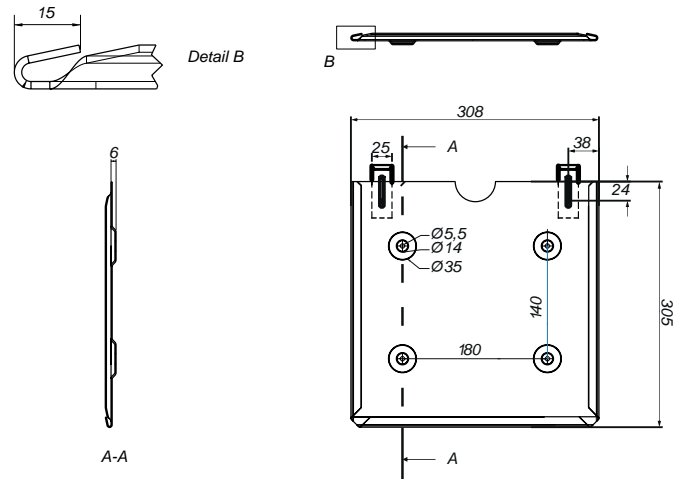
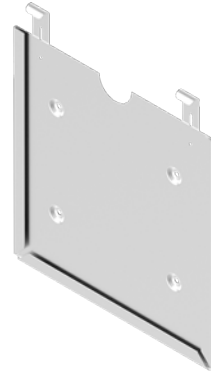

Aluminium Plate Holder 400x300 with Security Catch
Aluminium Warntafelhalter 400x300 mit Sicherungsbügel
Soporte Placa Aluminio 400x300 con pletinas de Seguridad

NEW

Ref	Kg	Mat	Lot
7201051	0.36		1

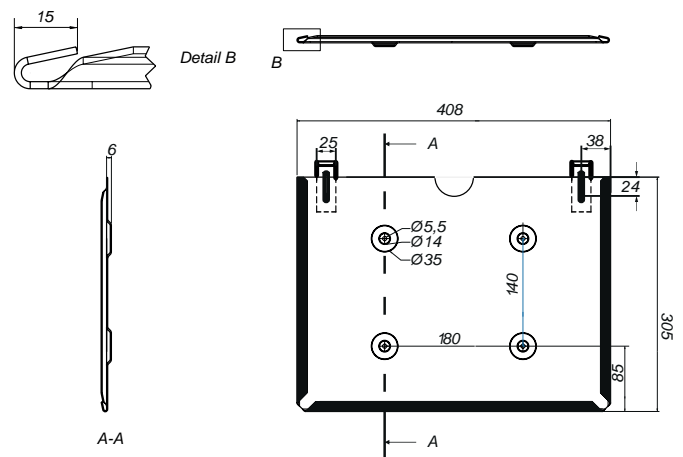
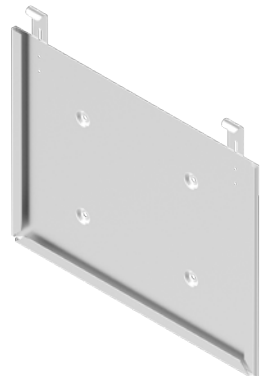

Interchangeable license plate holder
 Wechsel-Kennzeichenhalter
 Portamatrículas Intercambiable Gabarra

Ref	Kg	Mat	Col	Lot
7201028	0.56	STEEL	●	1

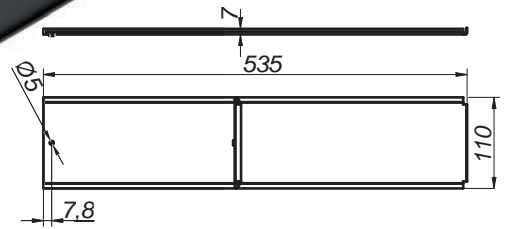
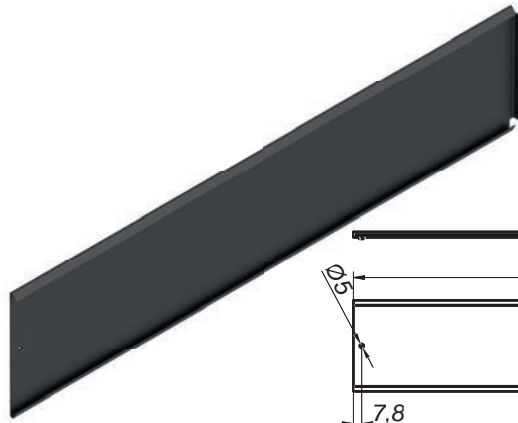

Pack 10 units License plate holder with spring
 Pack 10 units Wechsel-Kennzeichenhalter mit Feder
 Pack 10 uds. Soporte Matrícula Inox c/muelle

Ref	Kg	Mat	Lot	Pack
7201031	0.5	INOX	1	10

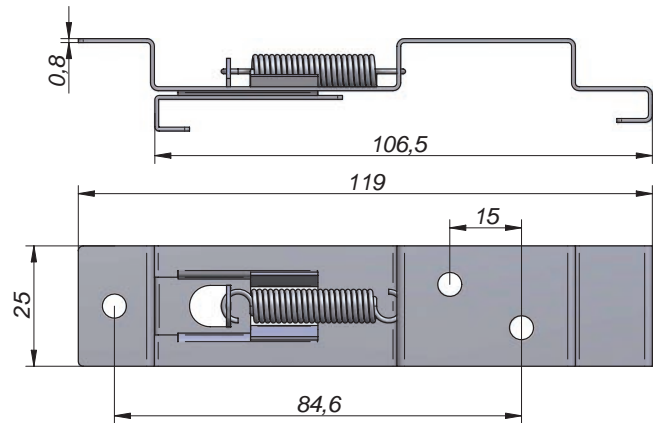

LIGHTING AND WARNING / BELEUCHTUNG UND MARKIERUNG / ILUMINACIÓN Y SEÑALIZACIÓN



MARCAJE V-23 V-23 MARKING

Reflective tape V-23 ECE-104 3M, Rigid
Konturmarkierungsband V-23 ECE-104 3M, Festaufbau
Rollo Retroreflectante V-23 ECE-104 3M, Camión Rígido

Ref	Kg	Mat	Col	Emark	Article	Vehic	Lot
7202060	1.54	GRP	Yellow	E ₁			1
7202064	1.54	GRP	White	E ₁			1
7202068	1.54	GRP	Red	E ₁			1

UNE-ECE 104



Reflective tape V-23 ECE-104 3M, Curtain Segmented
Konturmarkierungsband V-23 ECE-104 3M, Plane Segmentiert
Rollo Retroreflectante V-23 ECE-104 3M, Segmentada Lona

Ref	Kg	Mat	Col	Emark	Article	Vehic	Lot
7201032	1.25	GRP	Yellow	E ₁			1
7202067	1.25	GRP	Grey	E ₁			1
7202071	1.25	GRP	Red	E ₁			1

UNE-ECE 104



Reflective tape V-23 ECE-104 3M, Tanker
Konturmarkierungsband V-23 ECE-104 3M, Tankfahrzeug
Rollo Retroreflectante V-23 ECE-104 3M, Camión Cisterna

Ref	Kg	Mat	Col	Emark	Article	Vehic	Lot
7202072	1.44	GRP	Yellow	E ₁			1
7202074	1.44	GRP	White	E ₁			1
7202076	1.44	GRP	Red	E ₁			1

UNE-ECE 104



Reflective tape V-23 ECE-104 REFLEXITE, Rigid
 Konturmarkierungsband V-23 ECE-104 REFLEXITE, Festaufbau
 Rollo Retroreflectante V-23 ECE-104 REFLEXITE, Camión

Ref	Kg	Col	Emark	Article	Vehic	Lot
7202080	1	Yellow	E4			1
7202084	1	White	E4			1
7202088	1	Red	E4			1

UNE-ECE 104



Reflective tape V-23 ECE-104 REFLEXITE, Curtainsider
 Konturmarkierungsband V-23 ECE-104 REFLEXITE, Plane
 Rollo Retroreflectante V-23 ECE-104 REFLEXITE, para Lona

Ref	Kg	Col	Emark	Article	Vehic	Lot
7202082	1.3	Yellow	E4			1
7202086	1.3	White	E4			1
7202090	1.3	Red	E4			1

UNE-ECE 104



Reflective tape V-23 ECE-104 ORALITE, Tanker
 Konturmarkierungsband V-23 ECE-104 ORALITE, Tankfahrzeug
 Rollo Retroreflectante V-23 ECE-104 ORALITE, Cisterna

Ref	Kg	Col	Emark	Article	Vehic	Lot
7202092	1	Yellow	E4			1
7202094	1	White	E4			1
7202096	1	Red	E4			1

UNE-ECE 104



LIGHTING AND WARNING / BELEUCHTUNG UND MARKIERUNG / ILUMINACIÓN Y SEÑALIZACIÓN



MARCAJE V-2/V-23

V-2/V-23 MARKING



V-2 Weldable Strap Set Red/White (1L+1R) 9m.
 Band Set V-2 Rot/Weiss 3M (1Rechts+1Link) 9m.
 Kit Cinta V-2 Rojo/Blanco 3M (1dcho+1izdo) 9m.

NEW

Ref	Kg	Col	Article	Lot
7202050	1.56			1

For Assistance Vehicles | High Intensity Prismatic | Adhesive Type: rubber | retroreflective
 Para Vehículos de Auxilio | Exigidas por ITV | Prismático de alta intensidad | Tipo Adhesivo: caucho |
 Retroreflectante
 RD 159/2021, de 16 de marzo (servicios de auxilio) | RD 2822/1998, de 23 de diciembre (Reglamento
 General de Vehículos)

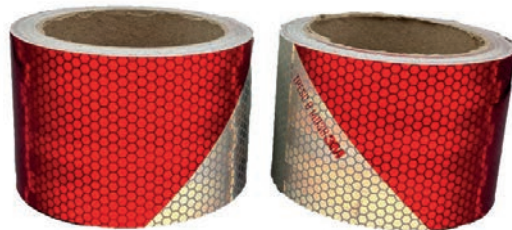

Señal V-2

Marcaje retroreflectante de vehículo obstáculo en la vía, con franjas rojas/blancas inclinadas 45° anchura mínima 14cm y máxima 55cm.

- Laterales: inclinación en sentido de la marcha.
- Delantera/trasera: "V" invertida.



Superficie mínima
delantera
0,16 m²

Superficie mínima
trasera
0,32 m²

Superficie mínima
lateral
0,16 m²



Blind Spot Pack 60 Units Sticky Label
 Pack 60 Units Sticky Label Blinder Fleck
 Pack 60 uds. Etiquetas adhesivas ángulo muerto

Ref	Kg	Mat	Article	Lot	Pack
7201002	0.7			1	60

In accordance with article L. 313-1 of the highway code, introduced by the article 55 of law no. 2019-1428 of December 24, 2019.
 De conformidad con el artículo L. 313-1 del código de circulación, introducido por el artículo 55 de la ley n. 2019-1428 del 24 de diciembre de 2019.
 UNE-ECE 104

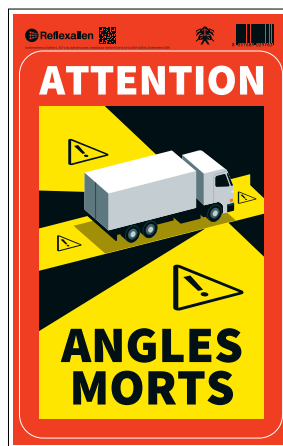

Puertas Traseras

Rear Door

Porte Arrière

Hecktüren

Portas Traseiras

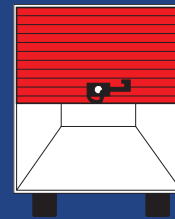

Freno Puerta

Spring Door Holder

Arrêts de Porte

Feder-Türfeststeller

Travão de Porta

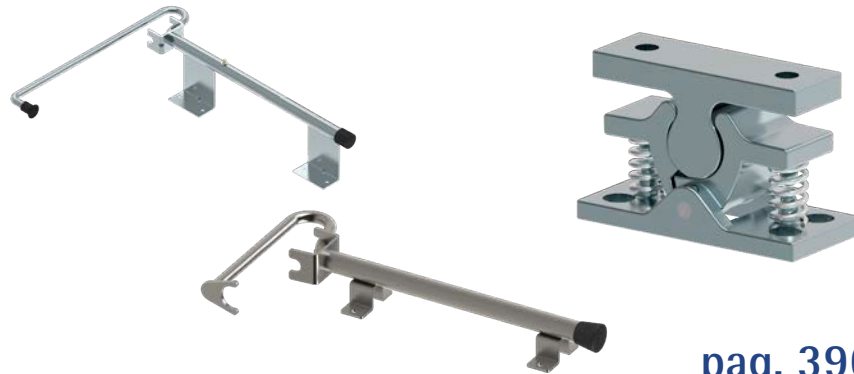

pag. 396-398

Sujetapuertas

Doorholder

Crochets D'arrêt

Türfeststeller

Travão de Portas



pag. 399-400

Manillas

Handles

Poignée

Handgriffe

Pegas



pag. 401-402

Puerta Elevable

Roll Shutters

Porte Relevante

Rolltore

Porta Elevatória



pag. 403-406



SPRING DOOR HOLDER / FEDER-TÜRFEHSTELLER / FRENO PUERTA

REAR DOOR AND ACCESSORIES / HECKTÜR-ZUBEHÖR UND HECKROLLADEN / PUERTAS TRASERAS

Spring Door Retainer (Ø25) Zinc Plated
Türfeststeller (Ø25) Verzinkt
Freno Puerta (Ø25) Cincado c/Muelle

Ref	Kg	Mat	Sup/Finish Acabado	Lot
1601018	2.43	STEEL	Zn	1

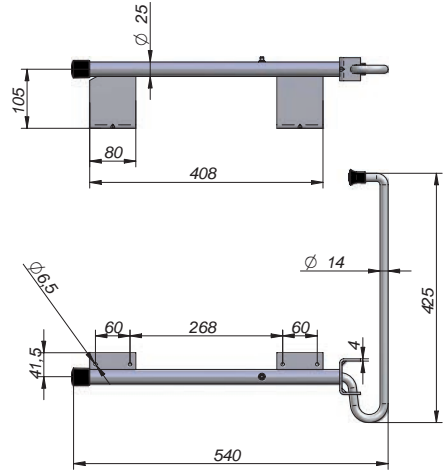

Spring Door Retainer (Ø25)
Türfeststeller (Ø25)
Freno Puerta (Ø25) c/Muelle

Ref	Kg	Mat	Sup/Finish Acabado	Lot
1601022	2.51	STEEL	Zn	2

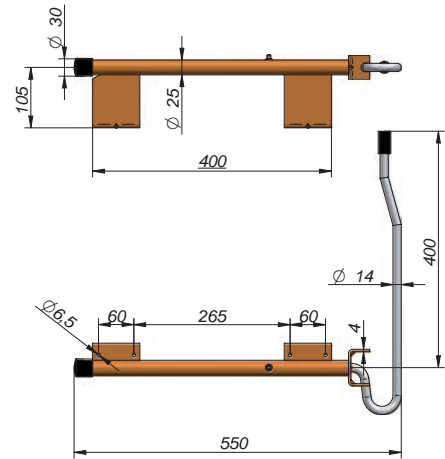

Spring Door Retainer (Ø28) Zinc Plated
Türfeststeller (Ø28) Verzinkt
Freno Puerta (Ø28) Cincado c/Muelle

Ref	Kg	Mat	Sup/Finish Acabado	Lot
1601019	2.32	STEEL	Zn	2

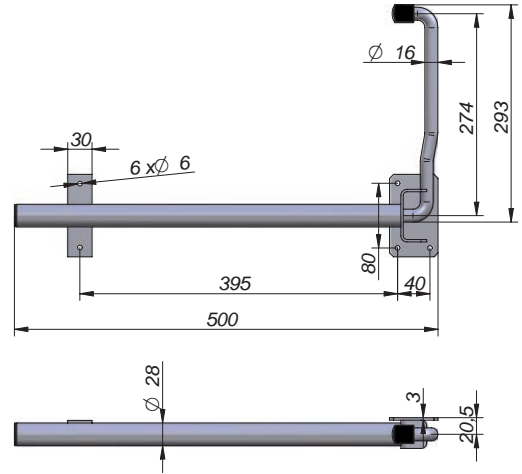

Spring Door Retainer (Ø28) Zinc Plated
Türfeststeller (Ø28) Verzinkt
Freno Puerta (Ø28) Cincado c/Muelle

Ref	Kg	Mat	Sup/Finish Acabado	Lot
1601030	2.8	STEEL	Zn	2

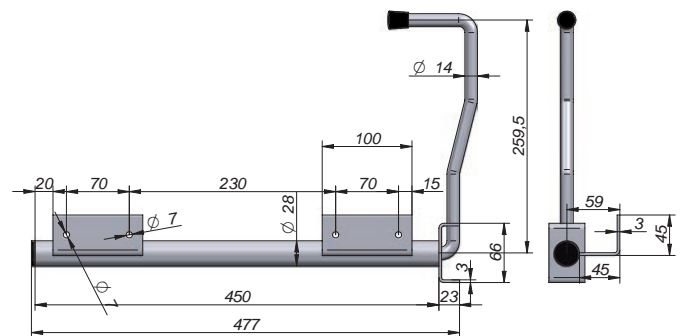

Stainless Steel Spring Door Retainer (Ø25)
 Türfeststeller (Ø25) Edelstahl
 Freno Puerta (Ø25) Inox c/Muelle c/Mango

Ref	Kg	Mat	Lot
1601074	1.98	INOX	1

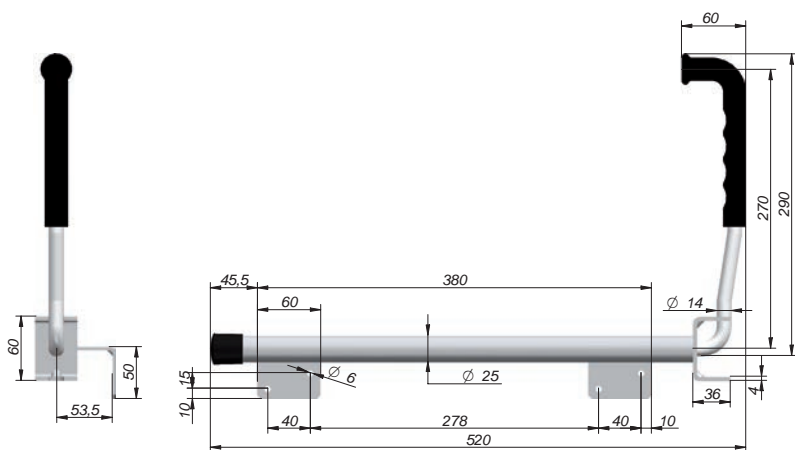
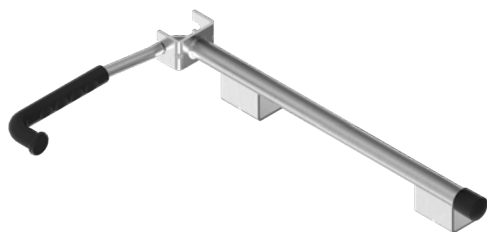

Stainless Steel Spring Door Retainer (Ø25) with Hook
 Türfeststeller (Ø25) Edelstahl mit Haken f. Drehstange
 Freno Puerta Inox (Ø25) c/Enganche a Leva

Ref	Kg	Mat	Lot
1601078	1.53	INOX	1

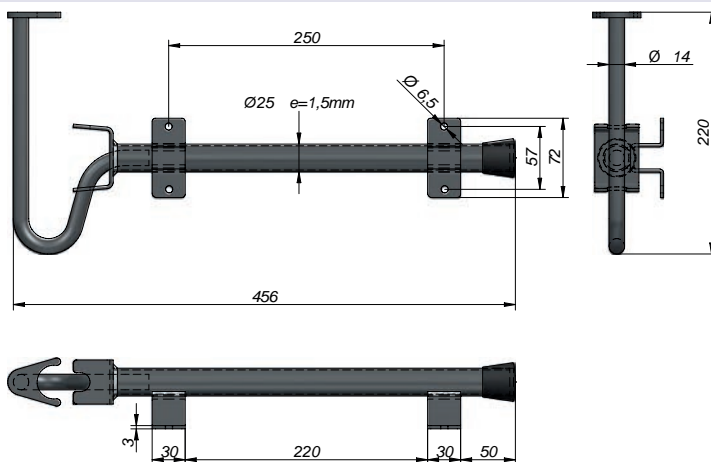
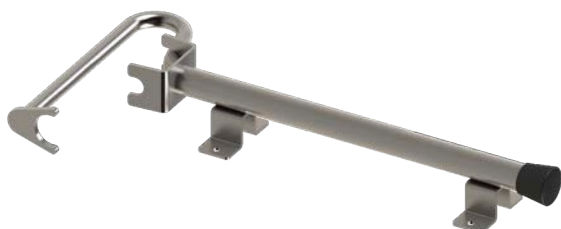

Spring Door Retainer (Ø30) Stainless Steel
 Türfeststeller (Ø30) Edelstahl
 Freno Puerta (Ø30) Inox c/Muelle

Ref	Kg	Mat	Lot
1601080	2.15	INOX	1

Plastic Handle
 Mango plástico

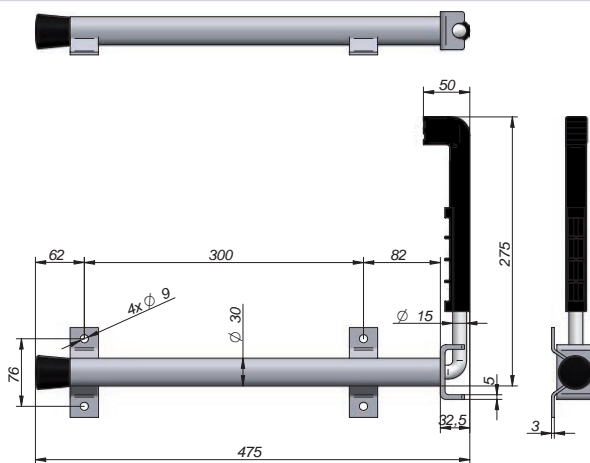

Spring Door Retainer (48) Alu-Stainless Steel
 Türfeststeller (48) Alu-Edelstahl
 Freno Puerta (48) Alu-Inox

NEW

Ref	Kg	Mat	Lot
1601082	2.4	INOX	1

Plastic Handle
 Mango plástico

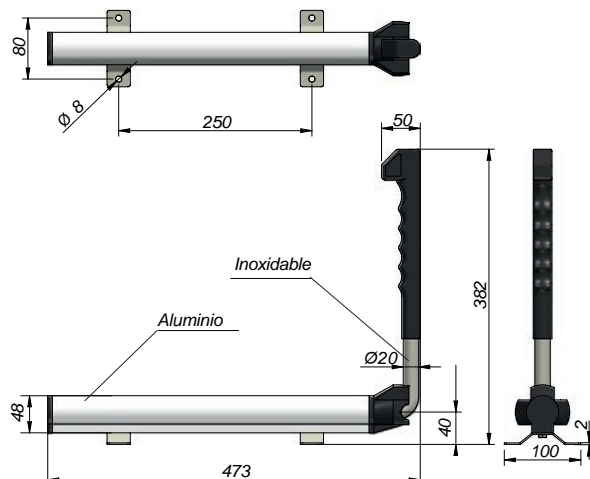

REAR DOOR AND ACCESSORIES / HECKTÜR-ZUBEHÖR UND HECKROLLADEN / PUERTAS TRASERAS

SPRING DOOR HOLDER / FEDER-TÜRFEHSTELLER / FRENO PUERTA

REAR DOOR AND ACCESSORIES / HECKTÜR-ZUBEHÖR UND HECKROLLADEN / PUERTAS TRASERAS

Nylon Door Retainer "Stopper" with Springs 414x310x57
 Türfeststeller "Stopper" Nylon mit Feder
 Freno Puerta Nylon c/Muelles "Stopper"

Ref	Kg	Mat	Lot
1601032	1.5	Ny	1

Body in nylon with springs in steel | Ergonomic handle with antislip grip |
 Spring system, perfect stop of the doors | Water/dust resistant
 Cuerpo en nylon, muelles en acero | Tirador ergonómico, grip antideslizante |
 Sistema de muelles, perfecta adherencia a puerta | Estanqueidad agua/polvo

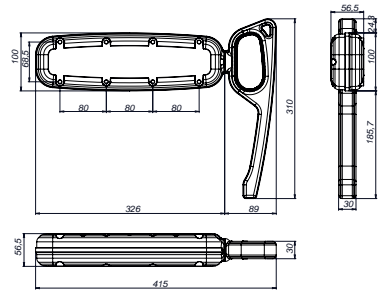

Vertical 2 Set Brackets H30 for Door Retainer "Stopper"
 Vertikal 2 Set Halter H30 für Türfeststeller "Stopper"
 Kit 2 Soportes Vertical H30 para Freno Puerta "Stopper"

Ref	Kg	Mat	Sup/Finish Acabado	Pos	Thickn. Espesor	Metric	Lot
1601035	0.22	STEEL	Galv		3	M6	1

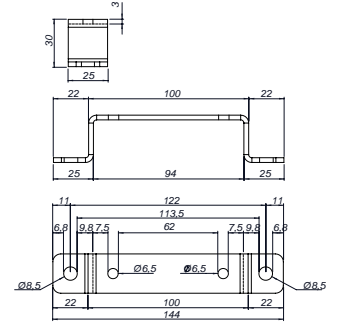
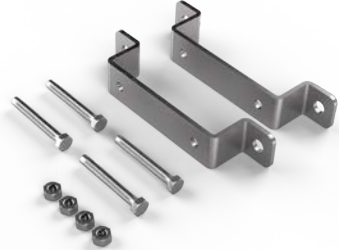

Vertical 2 Set Brackets H55 for Door Retainer "Stopper"
 Vertikal 2 Set Halter H55 für Türfeststeller "Stopper"
 Kit 2 Soportes Vertical H55 para Freno Puerta "Stopper"

Ref	Kg	Mat	Sup/Finish Acabado	Pos	Thickn. Espesor	Metric	Lot
1601036	0.28	STEEL	Galv		3	M6	1

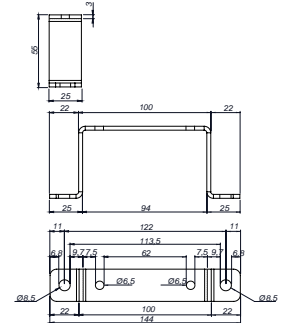
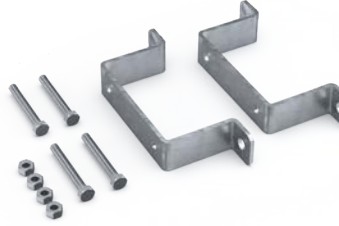

Vertical Bracket for Door Retainer "Stopper"
 Vertikal Halter für Türfeststeller "Stopper"
 Soporte Vertical para Freno Puerta "Stopper"

Ref	Kg	Mat	Sup/Finish Acabado	Pos	Thickn. Espesor	Metric	Lot
1601037	0.86	STEEL	Galv		3	M6	1

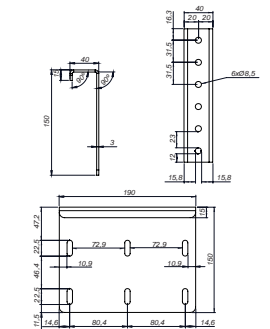

Door Retainer with Springs
 Feder-Türhalter
 Freno Puerta c/Muelles

Ref	Kg	Mat	Sup/Finish Acabado	Lot
1601136	0.24	STEEL	Zn	1

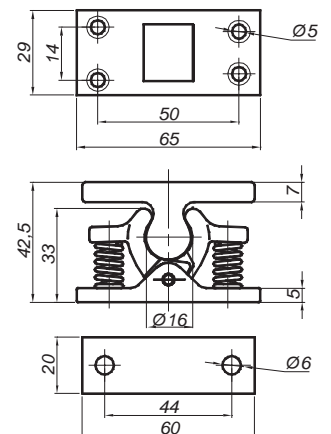

Door Holder Pin 65x40
Türfeststeller-Haken 65x40
Sujetapuertas Macho 65x40

Ref	Kg	Mat	Sup/Finish Acabado	Lot
1601130	0.06	STEEL	Zn	2
1601140	0.05	INOX		2

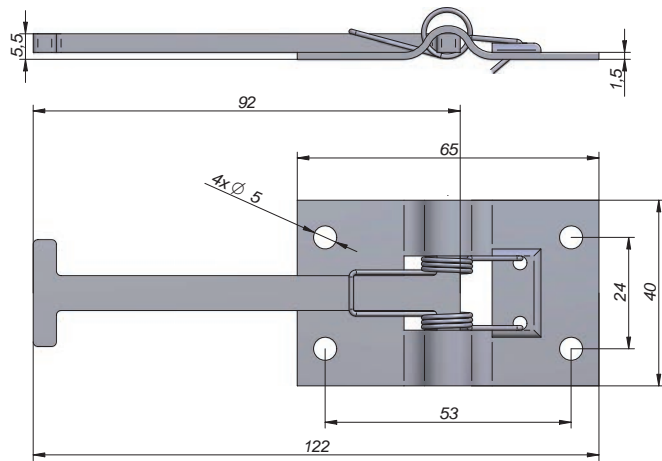

Plastic Base
Türfeststeller-Unterlage PVC
Base Sujetapuertas Plástico

Ref	Kg	Mat	Lot
1601172	0.01		2

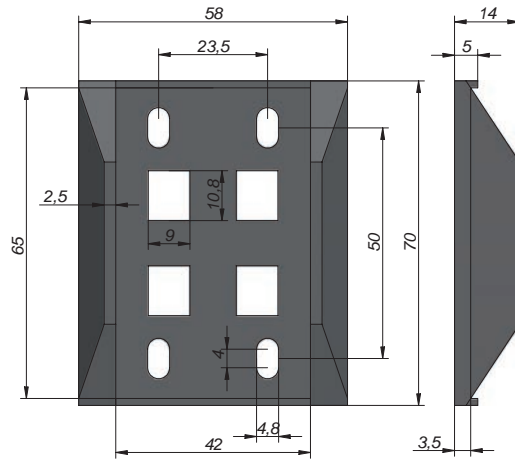

Door Holder Pin 80x45
Türfeststeller-Haken 80x45
Sujetapuertas Macho 80x45

Ref	Kg	Mat	Sup/Finish Acabado	Lot
1601131	0.07	STEEL	Zn	2
1601141	0.06	INOX		2

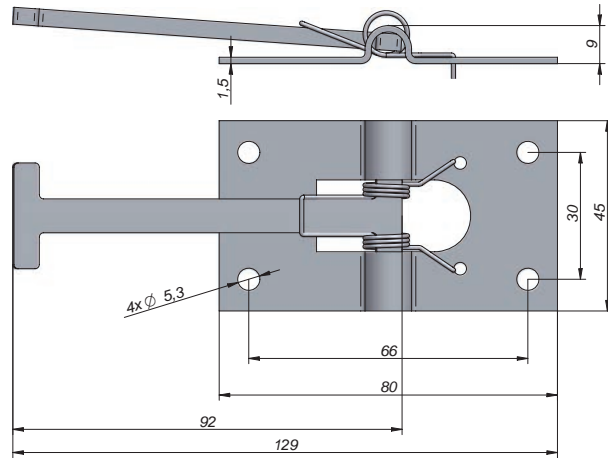

Door Holder Nut 80x45
Türfeststeller-Unterteil 80x45
Sujetapuertas Hembra 80x45

Ref	Kg	Mat	Sup/Finish Acabado	Lot
1601132	0.08	STEEL	Zn	2
1601142	0.07	INOX		2

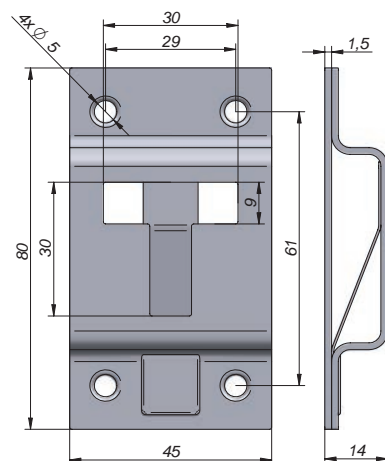
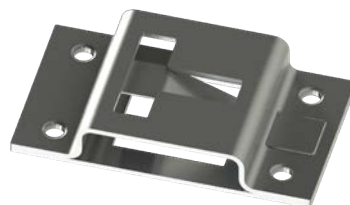



DOORHOLDER / TÜRFESTSTELLER / SUJETAPUERTAS

REAR DOOR AND ACCESSORIES / HECKTÜR-ZUBEHÖR UND HECKROLLADEN / PUERTAS TRASERAS

Base Plastic
Türfeststeller-Unterlage
Base Sujeta Puertas Plástico

Ref	Kg	Mat	Lot
1601174	0.02		2

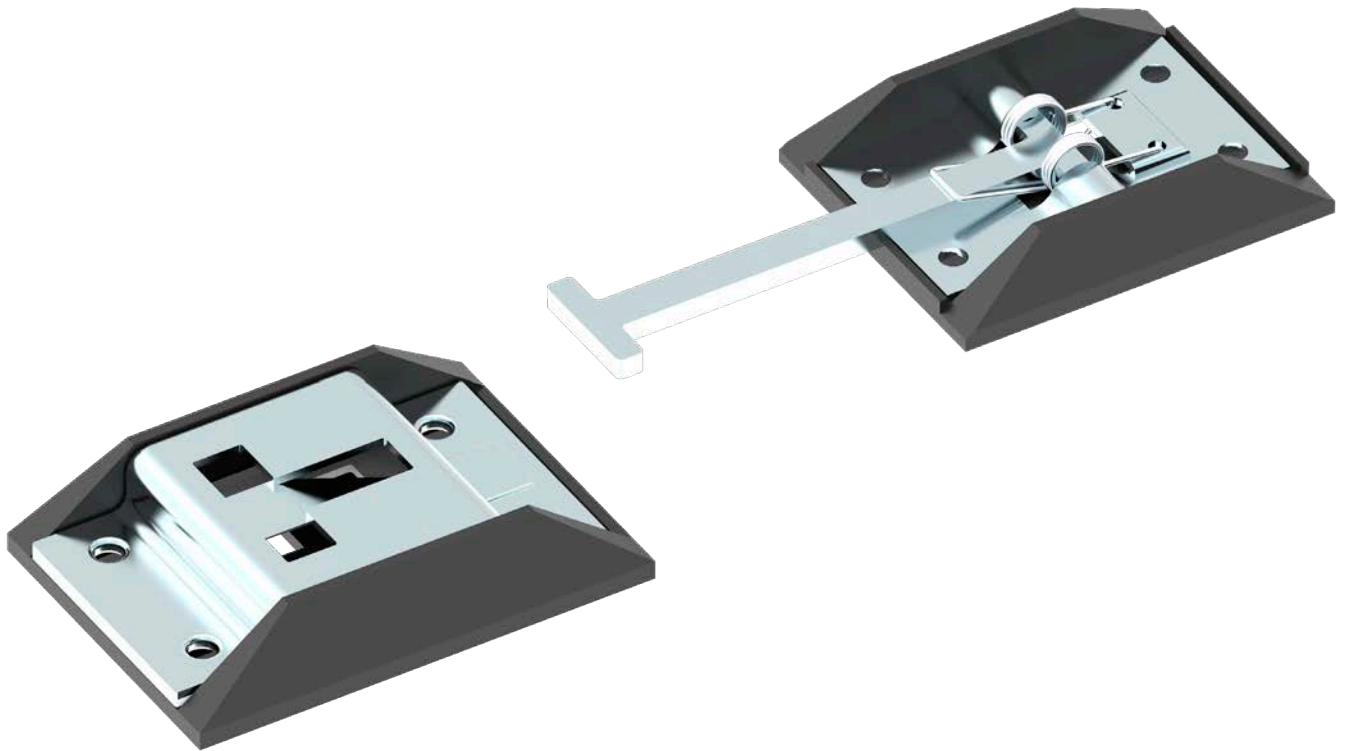
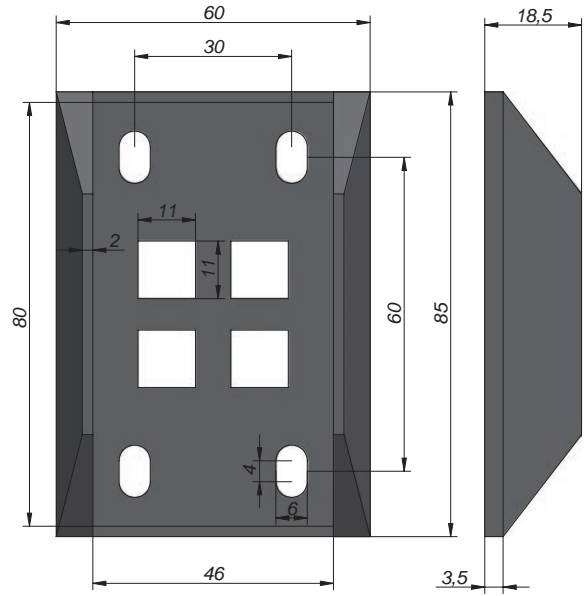

Handle 194x30x50 PVC
 Handgriff 194x30x50 PVC
 Asa 194x30x50 PVC

Ref	Kg	Mat	Lot
1602020	0.16		2

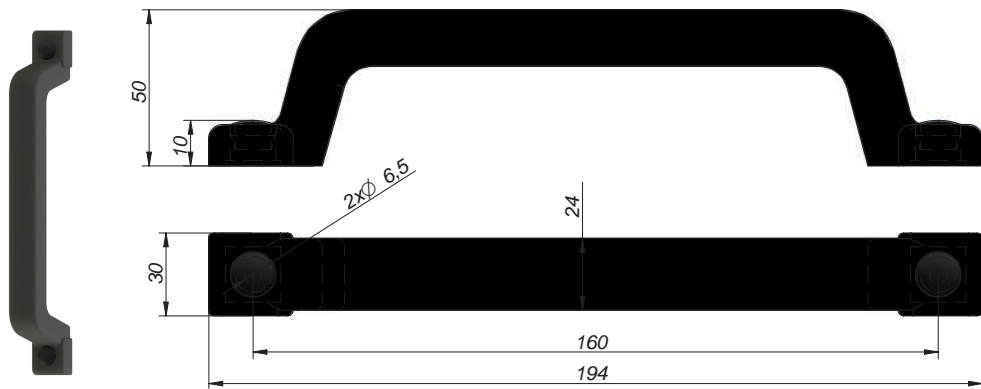

Handle 284x30x55 PVC
 Handgriff 284x30x55 PVC
 Asa 284x30x55 PVC

Ref	Kg	Mat	Lot
1602030	0.29		2

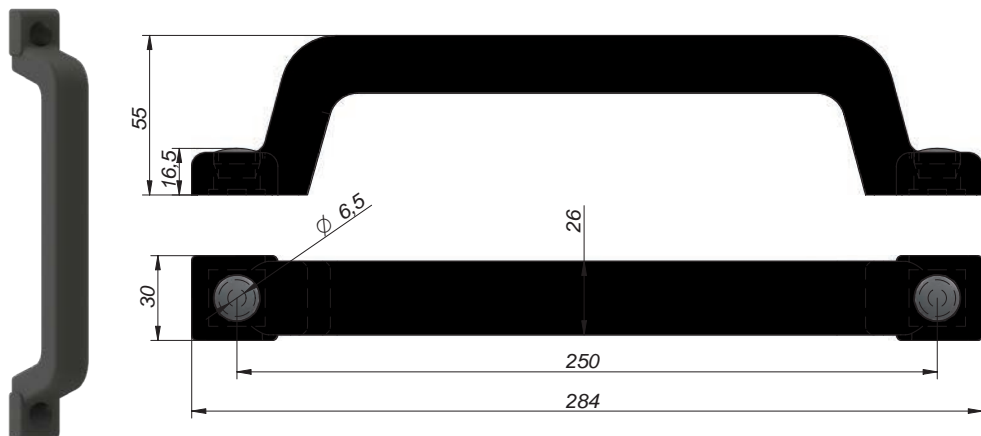

Handle 345x26x46 Stainless Steel
 Handgriff 345x26x46 Edelstahl
 Asa 345x26x46 Inox

Ref	Kg	Mat	Lot
1602122	0.42		1

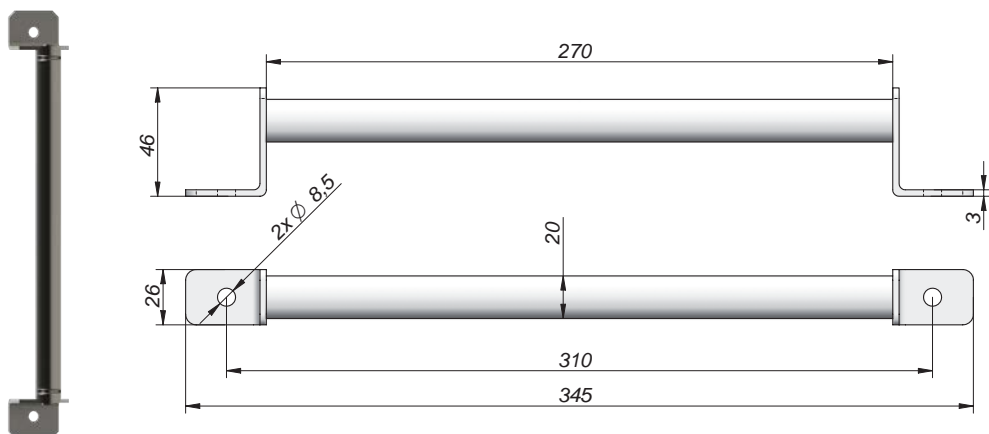

Handle 160x17x37 Aluminium
 Handgriff 160x17x37 Aluminium
 Asa 160x17x37 Aluminio

Ref	Kg	Mat	Col	Lot
1602138	0.07			2

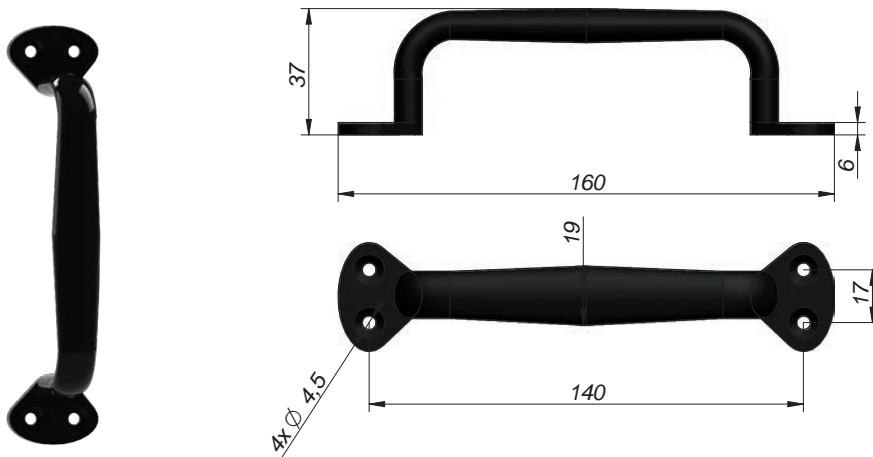



HANDLES / GRIFFE / MANILLAS

REAR DOOR AND ACCESSORIES / HECKTÜR-ZUBEHÖR UND HECKROLLADEN / PUERTAS TRASERAS

Runner Clamp 90x50 Stainless Steel
Kasten-Klappgriff 90x50 Edelstahl
Tirador Puerta 90x50 Inox

Ref	Kg	Mat	Lot
1602226	0.19	INOX	4

AISI 304

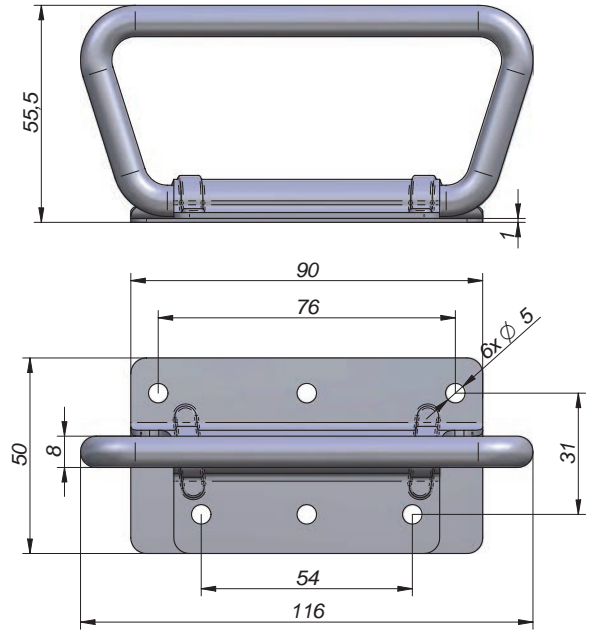

Runner Clamp 102x52 Zinc Plated
Kasten-Klappgriff 102x52 Verzinkt
Tirador Puerta 102x52 Cincado

Ref	Kg	Mat	Sup/Finish Acabado	Lot
1602230	0.23	STEEL	Zn	2

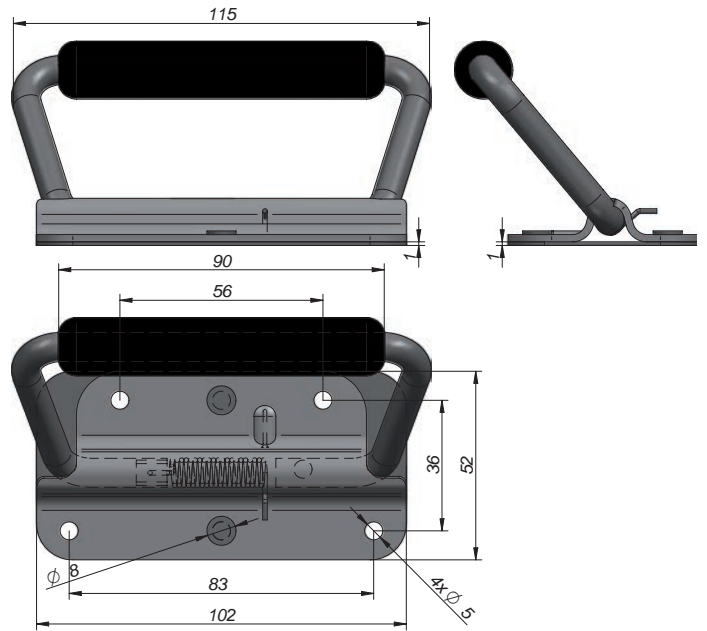



ROLL SHUTTERS

PUERTAS ELEVABLES

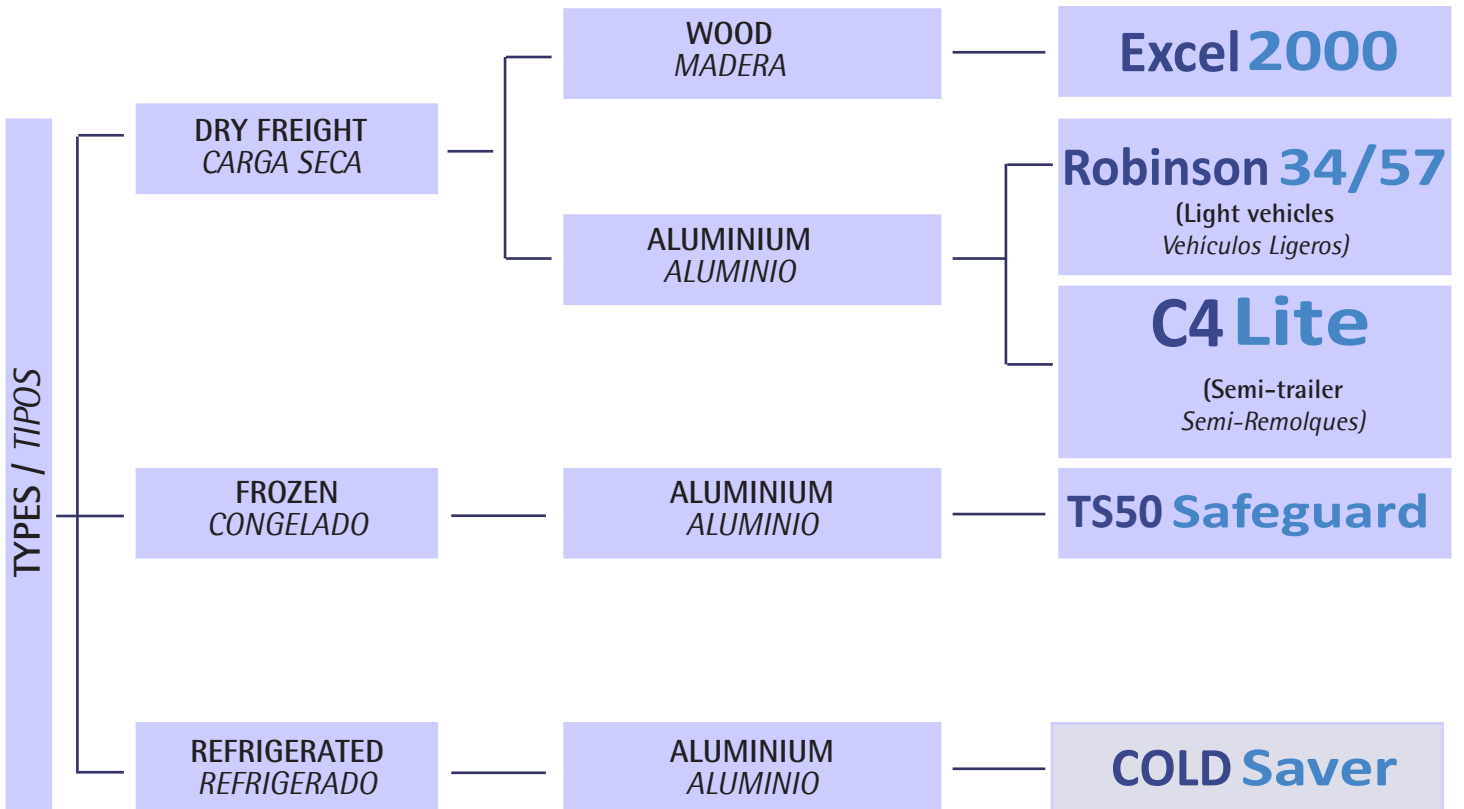



ROLL SHUTTERS / ROLLTOR / PUERTA ELEVABLE

REAR DOOR AND ACCESSORIES / HECKTÜR-ZUBEHÖR UND HECKROLLLADEN / PUERTAS TRASERAS

Wood Rollshutter with continuous hinge
Rolltor Holz mit durchgehendem Scharnier
Puerta Elevable de Madera c/Bisagra Continua

Ref	Kg	Mat	Lot
2201071	0		1

Dry Freight
Ask the Commercial Department for our order form
Carga Seca
Solicite al Departamento Comercial nuestro formulario de pedido



Seals / Perfiles de puerta

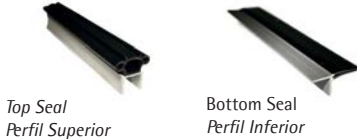

Top Seal
Perfil Superior

Bottom Seal
Perfil Inferior

The full width clip together aluminium continuous hinge provides ease of installation/removal and prevents water ingress during operation.
La bisagra continua de aluminio con clip de ancho completo facilita la instalación/extracción y evita la entrada de agua durante el funcionamiento.



Hinges Options / Opciones Bisagra

Lock Options / Opciones Cierres

(A) 70 Lock | (B) 70 C/W Yale cylinder | (C) 77 Lock complete with keeper | (D) C/W Assa Security Cylinder | (E) Maxi Lock
(A) 70 Cierre | (B) Cilindro Yale 70 C / W | (C) 77 Cerradura completa con seguro | (D) C / W Cilindro de seguridad Assa | (E) Maxi Lock



Aluminum Roll Shutter
Rolltor Aluminium
Puerta Elevable de Aluminio

Ref	Kg	Mat	Article	Lot
2201060	0			1
2201062	0			1

Dry Freight
Ask the Commercial Department for our order form
Carga Seca
Solicite al Departamento Comercial nuestro formulario de pedido

Sandwich

1 Box Section 34 mm. with nylon joint seals
Lamas de 34 mm. con juntas de nylon



1 Robinson 34mm Aluminium Shutter

2 Box Section 57 mm. open back no joint seals
Lamas de 57 mm. con juntas de nylon



2 Robinson 57mm Aluminium Shutter

DRY FREIGHT > ALUMINIUM CARGA SECA > ALUMINIO

34 Special Roll Shutter specially designed for fire fighting vehicles.
Puerta de aluminio para vehículos anti incendios.

57 Roll Shutter specifically designed to reduce fitting time.
Puerta de persiana diseñada para reducir el tiempo de ajuste.

Excel 2000



Two springs in each balancer ensure continuous operation if one spring fails.
Dos amortiguadores en cada equilibrador aseguran el funcionamiento continuo si falla un muelle versagt.

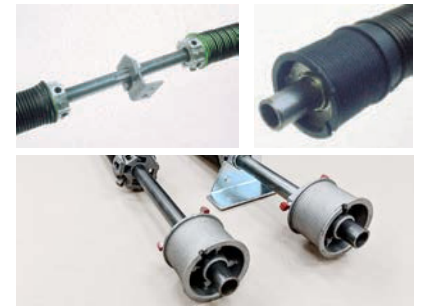

34
57



Side Seal Carrier
Soporte del perfil lateral



Bottom Rail Profiles
Perfiles inferiores

(A) Push Button with Remote Cylinder | (B) Locking T Handle | (C) Lift Bar Bottom Rail and Lift Bar Pivot Block | (D) Locking L Handle | (E) Locking T Handle | (F) Espagnolette Lock | (G) Hasp & Staple | (H) Pennant Plates - Slider Box
(A) Botón con cilindro remoto | (B) Manija en T de bloqueo | (C) Barra de elevación del perfil inferior y barra de elevación del eje de bloqueo | (D) Asa de bloqueo L | (E) Asa en T de bloqueo | (F) Cierre "Espagnolette" | (G) Cerrojo y grapa | (H) Banderines - lama deslizante.

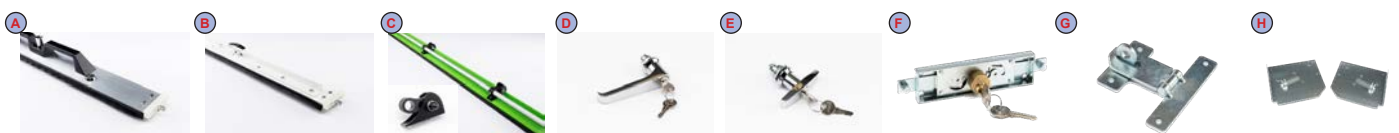



Aluminum Roll Shutter C4 LITE Rolltor Aluminium C4 LITE Puerta Elevable de Aluminio C4 LITE

Ref	Kg	Mat	Lot
2201076	0		1

Dry Freight | Semi-trailers 24T |
Ask the Commercial Department for our order form
Carga Seca | Semi-Remolques 24T |
Bisagra continua aluminio extruido reciclable |
Solicite al Departamento Comercial nuestro formulario de pedidos

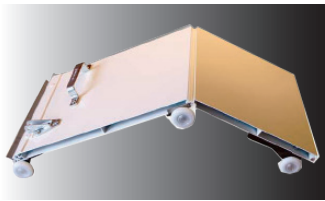
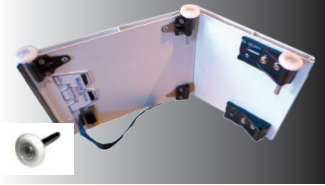

Main features/ Principales características

- 1.8mm thick centrally reinforced aluminium panels
 - EN12642 (XL) certified to 22.5 tonne payload
 - Zytel top closure bracket and roller holders
 - 50mm diameter sealed nylon rollers with stainless steel shaft
 - Maximum security lock as standard
 - Single or twin spring balancer
 - Integral extruded aluminium continuous hinge
-
- Paneles de aluminio con refuerzo central de 1,8 mm de espesor EN12642 (XL) certificados para 22,5 toneladas de carga útil.
 - Soporte de cierre superior Zytel y soportes de rodillos.
 - Rodillos de nylon sellados de Ø50 mm de con eje en inoxidable.
 - Cerradura de máxima seguridad.
 - Amortiguador simple o doble.
 - Bisagra continua de aluminio extruido integral

C4 Lite



Single Spring Balancer Equilibrador de un solo muelle



Optional Twin Spring Balancer Equilibrador opcional doble muelle

(A) Anti Lozenge Brackets & Zytel Roller Holder | (B) Top Closure Bracket With Zytel Slider | (C) Top Seal Capping | (D) Type 70 Bottom Seal Carrier & Seal | (E) Bottom Roller bracket & Stainless steel Holder | (F) Grab Handle | (G) Maxi Lock | (H) Type 77 Lock | (I) Type 70 Lock

(A) Soportes "anti-rombo" y soporte de rodillos Zytel | (B) Soporte de cierre superior con Zytel Slider | (C) tapa perfil superior | (D) Portador y sello del sello inferior tipo 70 | (E) Soporte de rodillo inferior y soporte de acero inoxidable | (F) agarra la manija | (G) Maxi Lock | (H) Bloqueo tipo 77 | (I) Bloqueo Tipo 70



Aluminum Roll Shutter TEMPSAVER Rolltor Aluminium TEMPSAVER Puerta Elevable de Aluminio TEMPSAVER

Ref	Kg	Mat	Article	Lot
2201084	0		Anti finger trap Anti atrapados	1

Insulated Frozen Door | 50mm polyurethane (CFC) free foam insulation. |
Ask the Commercial Department for our order form
Puerta con aislamiento para Carga Congelada |
Espuma PUR de 50 mm (libre de CFC) |
Solicite al Departamento Comercial nuestro formulario de pedidos
Certificado ATP (Transporte Mercancías Perecederas)



Steel Roller with Stainless Steel Shaft
Rodamiento en Acero con eje en Inoxidable



Mounting angle & side seal. The Side seals are effective throughout the full operating cycle.
Perfil lateral y ángulo de montaje. Las juntas laterales son efectivas durante todo el ciclo operativo.

Stainless steel end hinge and roller carrier. Removable cap allows roller change without removing hinge.
Bisagra con extremo de acero inoxidable y soporte de rodillo. La tapa extraíble permite el cambio de rodillo sin quitar la bisagra.
Charnière avec extrémité en acier inoxydable et support de

(A) Dual durometer top seal for maximum thermal performance. | (B) Top Seal Capping | (C) Centre Hinge - Stainless Steel | (D) End Hinges & Roller Holder - Stainless Steel | (E) Bottom Roller Holder | (F) Type 75-10 Lock | (G) Type 77 Lock

(A) Perfil superior de duometría doble para un rendimiento térmico máximo. | (B) Tapa del perfil superior | (C) Bisagra central de Acero inoxidable | (D) Bisagras de extremo y soporte del rodillo de Acero inoxidable | (E) Soporte del rodillo inferior | (F) Cierre Tipo 75-10 | (G) Cierre Tipo 77

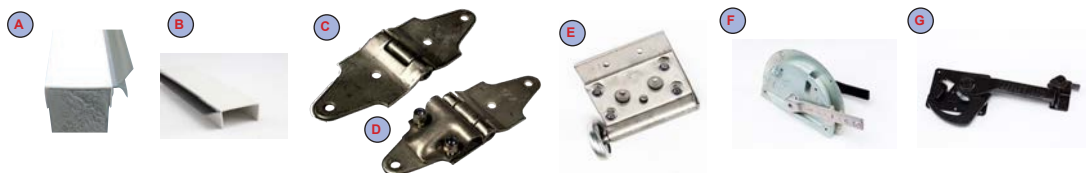

TS50 Safeguard

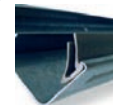

50mm polyurethane (CFC) free foam insulation
Aislamiento de espuma libre de poliuretano de 50 mm (CFC)



Single Spring Balancer
Single-Federwelle



ROLL SHUTTERS / ROLLTOR / PUERTA ELEVABLE

REAR DOOR AND ACCESSORIES / HECKTÜR-ZUBEHÖR UND HECKROLLLADEN / PUERTAS TRASERAS

Aluminum Roll Shutter COLD SAVER
Rolltor Aluminium COLD SAVER
Puerta Elevable de Aluminio COLD SAVER

Ref	Kg	Mat	Lot
2201086	0		1

Insulated | Refrigerated truck |
60mm polyurethane (CFC) free foam insulation |
Ask the Commercial Department for our order form
Puerta con aislamiento para Carga Congelada |
Espuma PUR de 60 mm (libre de CFC) |
Solicite al Depto Comercial nuestro formulario de pedidos
Certificado ATP (Transporte Mercancías Perecederas)



Steel roller with stainless steel shaft
Rodamiento en Acero con eje en Inoxidable



(A) Top Seal Capping | (B) Bottom Seal Carrier & Bottom Seal (C) Bottom Roller Holder | (D) Type 75-10 Lock | (E) Type 77 Lock
(A) Tapa de perfil superior | (B) Soporte del perfil inferior y junta inferior (C) Soporte inferior del rodillo | (D) Cierre tipo 75-10 | (E) Cierre tipo 77

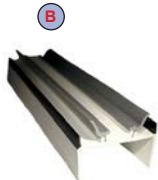

REFRIGERATED > ALUMINIUM REFRIGERADO > ALUMINIO

Aluminium Roll Shutter ideal for ATP class "C" specification vehicles. With outstanding temperature control, it is easily and quickly installed by one person.

Puerta de aluminio ideal para vehiculos refrigerados con especificación ATP clase C. (Transporte Mercancías Perecederas). Excelente control de temperatura, fácil de montar por una persona.

Mounting angle & side seal. The Side seals are effective throughout the full operating cycle.

Ángulo de montaje y sello lateral. Los sellos laterales son efectivos durante todo el ciclo operativo.



Stainless steel end hinge and roller carrier. Removable cap allows roller change without removing hinge.

Bisagra de acero inoxidable y soporte de rodillo. La tapa extraíble permite el cambio de rodillo sin quitar la bisagra.

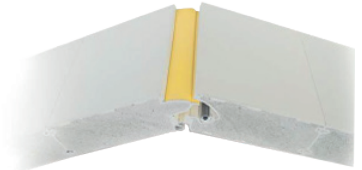

Enclosed Spring Balancer
Umschlossene Federwelle

COLD Saver



Seguridad y Antirrobo

Safety and Antitheft

Sécurité et Antivol

Sicherheit/Diebstahlsicherung

Segurança e Anti-Roubo



Seguridad

Safety Material

Matériel de sécurité

Sicherheit

Segurança



pag. 408

Tapones Gasoil/Antirrobo

Tank Caps & Antitheft

Bouchon et Antivols

Tankdeckel und

Diebstahlsicherung

Tampas Gasóleo e

Anti-Roubo

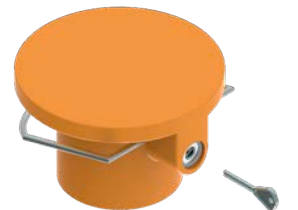

pag. 409-422

Warning triangle
 Warndreieck
 Triángulo de avería

Ref	Kg	Mat	Col	Emark	Lot
70113901	0.4	PVC ABS PMMA			1

UNE ECE R 27



Emergency tool
 Nothammer
 Martillo de emergencia

Ref	Kg	Lot
70110003	0.2	1

CE
 EN ISO 12100 : 2010



Safety vest
 Warnweste
 chaleco reflectante

Ref	Kg	Mat	Col	Lot
79620032	0.16	GRP		1

One size
 Talla Única
 EN 20471: 2013+A1 2016



TANK CAPS AND ANTITHEFT / TANKDECKEL & DIEBSTAHLSICHERUNGEN / TAPAS GASOIL Y ANTIRROBOS



SAFETY AND ANTI-THEFT SYSTEMS / SICHERHEIT UND DIEBSTAHLSICHERUNGEN / SEGURIDAD Y ANTIRROBOS

Anti Theft Fuel Device
Kraftstoff-Diebstahlsicherung
Antirrobo de Gasoil c/Patillas

Ref	Kg	Mat	Sup/Finish Acabado	Ø	Lot
6702112	0.583	STEEL	Zn	80	1

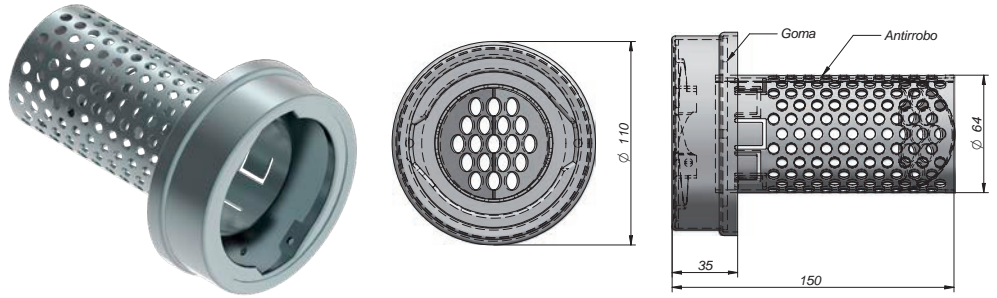

Anti Theft Fuel Device SCANIA S4
Kraftstoff-Diebstahlsicherung SCANIA S4
Antirrobo de Gasoil SCANIA S4

Ref	Kg	Mat	Sup/Finish Acabado	Ø	Lot
6702116	0.68	STEEL	Zn	60	1

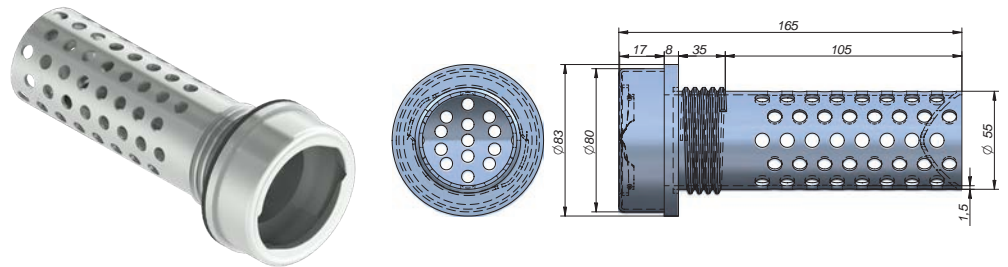

Anti Theft Fuel Device SCANIA C/Rosca Int-Ext
Kraftstoff-Diebstahlsicherung SCANIA C/Rosca Int-Ext
Antirrobo de Gasoil c/rosca int-ext, SCANIA

Ref	Kg	Mat	Sup/Finish Acabado	Lot
6702117	0.739	STEEL	Zn	1

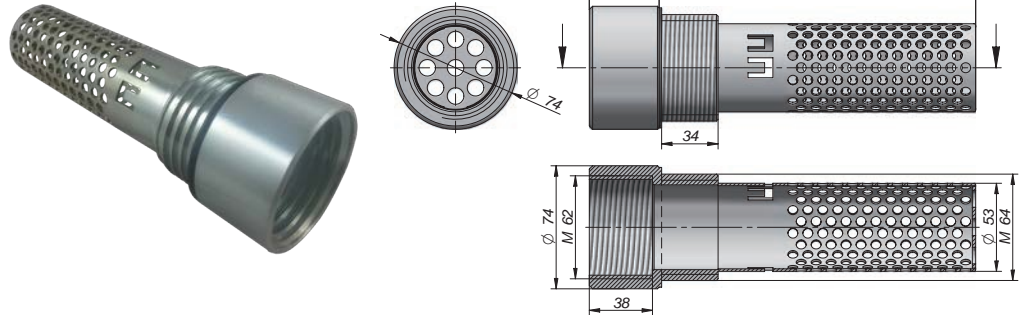

Anti Theft Fuel Device Universal
Kraftstoff-Diebstahlsicherung Universal
Antirrobo de Gasoil Universal

Ref	Kg	Mat	Sup/Finish Acabado	Ø	Thickn. Espesor	Lot
6702118	0.4	STEEL	Zn	60	1.5	1

It includes protective rubber bag and installation set: 2 rivets, drill and pin
Incluye goma de protección y bolsa con set de instalación: 2 remaches, broca y pasador

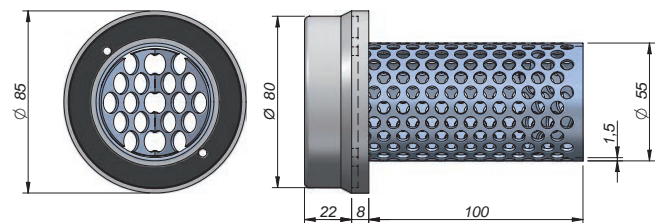



TANK CAPS AND ANTITHEFT / TANKDECKEL & DIEBSTAHLSICHERUNGEN / TAPAS GASOIL Y ANTIRROBOS

SAFETY AND ANTI-THEFT SYSTEMS / SICHERHEIT UND DIEBSTAHLSICHERUNGEN / SEGURIDAD Y ANTIRROBOS

Anti Theft Fuel Device
Kraftstoff-Diebstahlsicherung
Antirrobo de Gasoil

Ref	Kg	Mat	Sup/Finish Acabado	Lot
6702120	0.347	STEEL	Zn	1

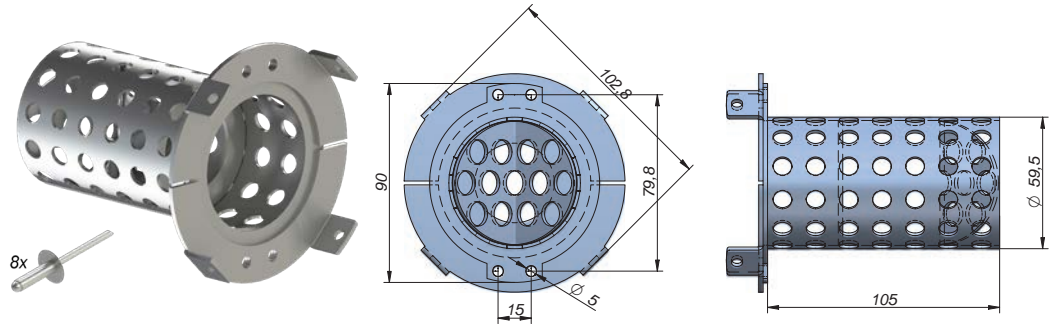

Anti Theft Fuel Device Universal Aluminium
Kraftstoff-Diebstahlsicherung Universal Aluminium
Antirrobo de Gasoil de Aluminio, Universal

Ref	Kg	Mat	Lot
6702132	0.564		1

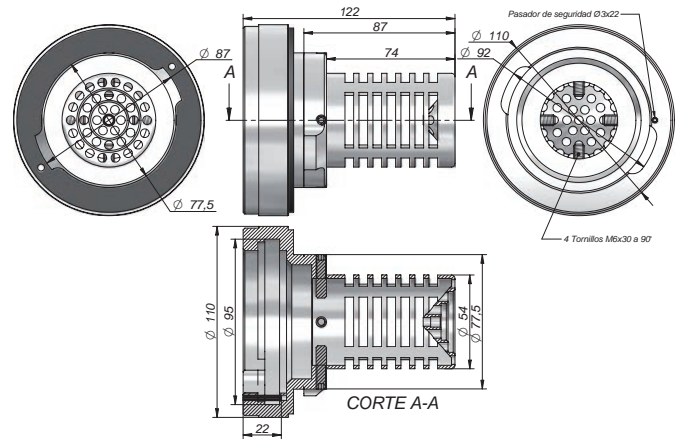

Anti Theft Fuel Device SCANIA Aluminium
Kraftstoff-Diebstahlsicherung SCANIA Aluminium
Antirrobo de Gasoil de Aluminio c/rosca int-ext, SCANIA

Ref	Kg	Mat	Lot
6702134	0.387		1

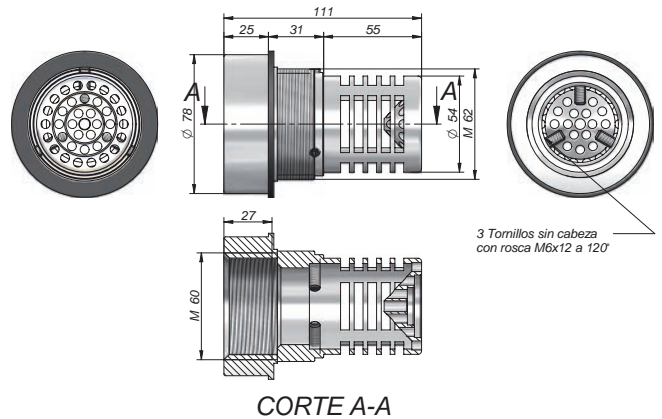

Antitheft for Fuel Cap SCANIA-IVECO Ø60
Diebstahlsicherung für Tankdeckel SCANIA-IVECO Ø60
Antirrobo de Tapón Gasoil SCANIA-IVECO Ø60

Ref	Kg	Mat	Sup/Finish Acabado	Col	Key Llave	Lot
7205001	1.19	STEEL		Black	Key	1

for SCANIA/IVECO | For filler neck external diameter less than 85mm | Side opening
Para SCANIA/IVECO | Para Ø exterior del depósito menor a 85 mm. | Apertura Lateral



TANK CAPS AND ANTITHEFT / TANKDECKEL & DIEBSTAHLSICHERUNGEN / TAPAS GASOIL Y ANTIRROBOS



Antitheft for Fuel Cap Universal Ø80
 Diebstahlsicherung für Tankdeckel Universal Ø80
 Antirrobo de Tapón Gasoil Universal Ø80

Ref	Kg	Mat	Sup/Finish Acabado	Col	Key Llave	Lot
7205003	1.25	STEEL				1

Universal type for most Europe trucks, such as M-B/VOLVO/MAN/DAF/IVECO/RENAULT | Generally for all filler necks with a external Ø=105 mm.
 Para MB-VOLVO-MAN-DAF-IVECO-RENAULT | Para Ø exterior del depósito = 105 mm.



Antitheft for Fuel Cap Universal Ø80 Side Opening
 Diebstahlsicherung für Tankdeckel Universal Ø80 Seitenöffnung
 Antirrobo de Tapón Gasoil Universal Ø80 Apertura Lateral

Ref	Kg	Mat	Sup/Finish Acabado	Col	Key Llave	Lot
7205005	1.25	STEEL				1

Universal type for most Europe trucks, such as M-B/VOLVO/MAN/DAF/IVECO/RENAULT | Generally for all filler necks external Ø=105 mm. | Side opening
 Para MB-VOLVO-MAN-DAF-IVECO-RENAULT | Para Ø exterior del depósito = 105 mm. | Apertura lateral



Antitheft for Fuel Cap
 Diebstahlsicherung für Tankdeckel
 Antirrobo de Tapón de Gasoil

Ref	Kg	Mat	Sup/Finish Acabado	Col	Key Llave	Lot
7205002	2.38	STEEL				1

Fixing by means of a ring to the filler neck with 4 screws (they are covered when installing the anti-theft device)
 Bombillo tubular de 7 puntos. Fijación mediante anillo a la boca de llenado con 4 tornillos (quedan cubiertos al colocar el antirrobo).

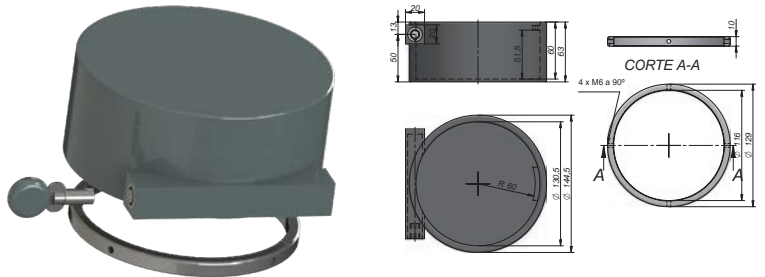

Antitheft For Fuel Cap Universal Ø105 Open
 Diebstahlsicherung für Tankdeckel Universal Ø105 Offen
 Antirrobo de tapón de Gasoil Abierto Universal Ø105

Ref	Kg	Mat	Key Llave	Lot
7205004	0.575	STEEL		1

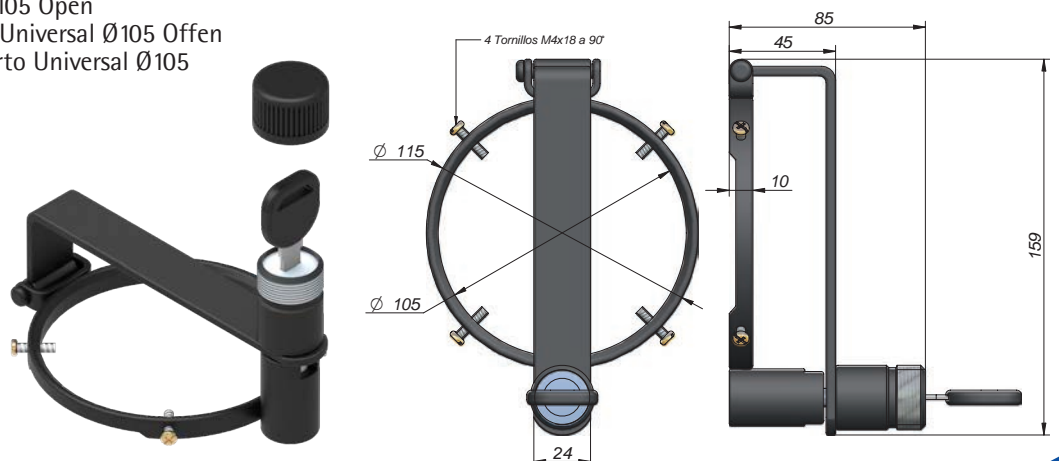

SAFETY AND ANTI-THEFT SYSTEMS / SICHERHEIT UND DIEBSTAHLSICHERUNGEN / SEGURIDAD Y ANTIRROBOS



TANK CAPS AND ANTI-THEFT / TANKDECKEL & DIEBSTAHLSICHERUNGEN / TAPAS GASOIL Y ANTIRROBOS

SAFETY AND ANTI-THEFT SYSTEMS / SICHERHEIT UND DIEBSTAHLSICHERUNGEN / SEGURIDAD Y ANTIRROBOS

Anti theft For Fuel Cap SCANIA Open
Diebstahlsicherung für Tankdeckel SCANIA Offen
Antirrobo de tapón de Gasoil Abierto SCANIA

Ref	Kg	Mat	Key Llave	Lot
7205006	0.575	STEEL		1

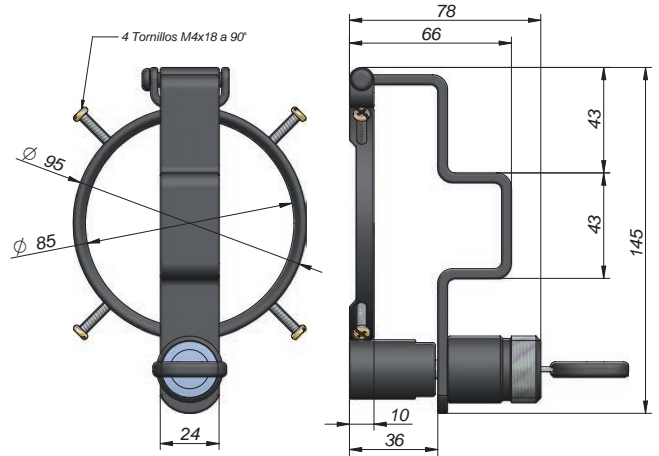

Plastic Tank Cap SCANIA
Tankdeckel Kunststoff SCANIA
Tapón Depósito SCANIA Plástico

Ref	Kg	Key Llave	Lot
6702020	0.183		1

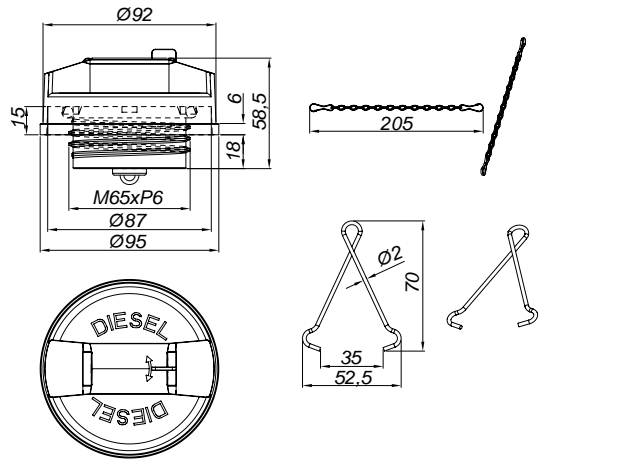

Tank Cap SCANIA
Tankdeckel SCANIA
Tapón Depósito SCANIA

Ref	Kg	Key Llave	Lot
6702018	0.255		1

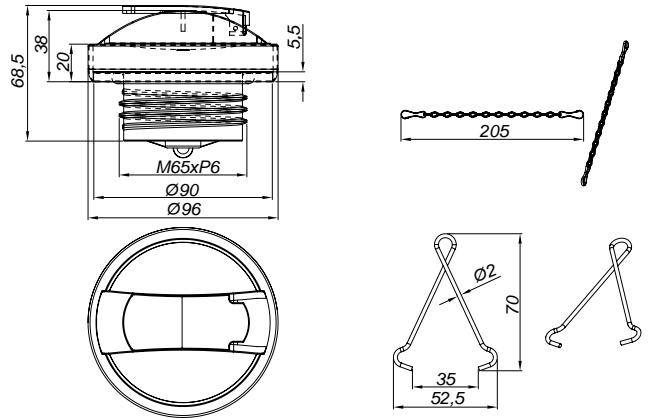

Tank Cap Ø80 AXOR-ATEGO-VOLVO-IVECO
Tankdeckel Ø80 AXOR-ATEGO-VOLVO-IVECO
Tapón Ø80 AXOR-ATEGO-VOLVO-IVECO

Ref	Kg	Mat	Ø	Key Llave	Lot
6702026	0.406		80		1

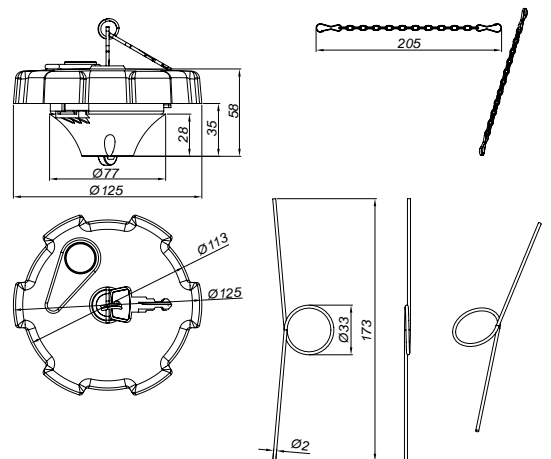

TANK CAPS AND ANTITHEFT / TANKDECKEL & DIEBSTAHLSICHERUNGEN / TAPAS GASOIL Y ANTIRROBOS



SAFETY AND ANTI-THEFT SYSTEMS / SICHERHEIT UND DIEBSTAHLSICHERUNGEN / SEGURIDAD Y ANTIRROBOS

Tank Cap Ø80 Stainless Steel
Tankdeckel Ø80 Edelstahl
Tapón Depósito Ø80 Inox

Ref	Kg	Mat	Ø	Key Llave	Lot
6702012	0.54	INOX	80		1

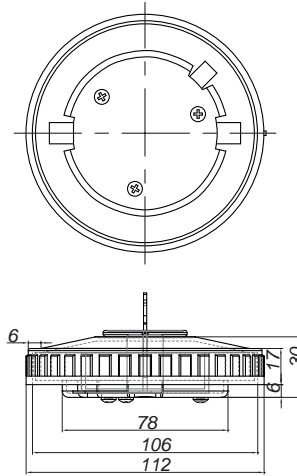
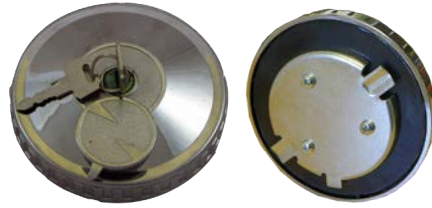

Tank Cap Ø60
Tankdeckel Ø60
Tapón Depósito Ø60

Ref	Kg	Mat	Ø	Key Llave	Lot
6702040	0.27	STEEL	60		1

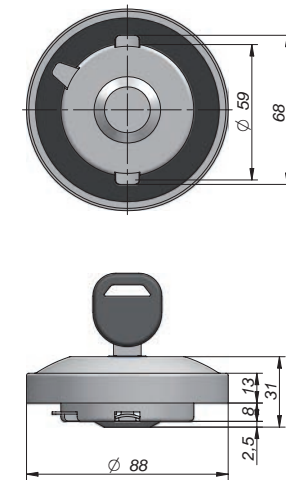

Metal fuel tank cap Ø80
Tankdeckel Ø80 Verchromt
Tapón Ø80 Cromado

Ref	Kg	Mat	Sup/Finish Acabado	Ø	Key Llave	Lot
6702014	0.1	STEEL	Cr	80		1

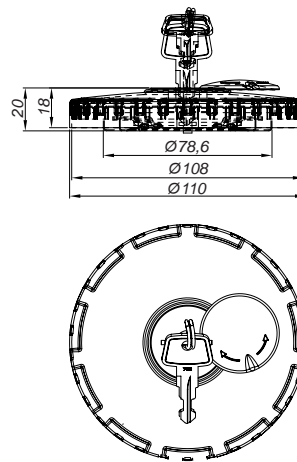

Tank Cap AdBlue Ø40 DAF/MAN/MERCEDES
Tankdeckel AdBlue Ø40 DAF/MAN/MERCEDES
Tapón AdBlue Ø40 DAF/MAN/MERCEDES

Ref	Kg	Ø	Key Llave	Lot
6702044	0.133	40		1

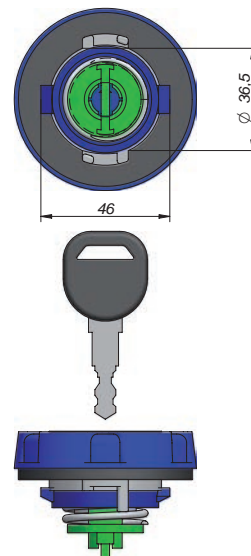



TANK CAPS AND ANTITHEFT / TANKDECKEL & DIEBSTAHLSICHERUNGEN / TAPAS GASOIL Y ANTIRROBOS

SAFETY AND ANTI-THEFT SYSTEMS / SICHERHEIT UND DIEBSTAHLSICHERUNGEN / SEGURIDAD Y ANTIRROBOS

Tank Cap AdBlue Ø60 IVECO
Tankdeckel AdBlue Ø60 IVECO
Tapón AdBlue Ø60 IVECO

Ref	Kg	Ø	Key Llave	Lot
6702046	0.206	60		1

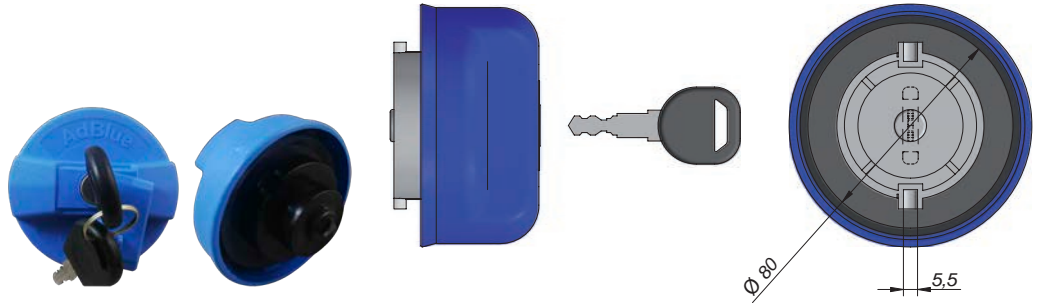

Tank Cap AdBlue Ø60 RENAULT/VOLVO
Tankdeckel AdBlue Ø60 RENAULT/VOLVO
Tapón AdBlue Ø60 RENAULT/VOLVO

Ref	Kg	Ø	Key Llave	Lot
6702048	0.211	60		1

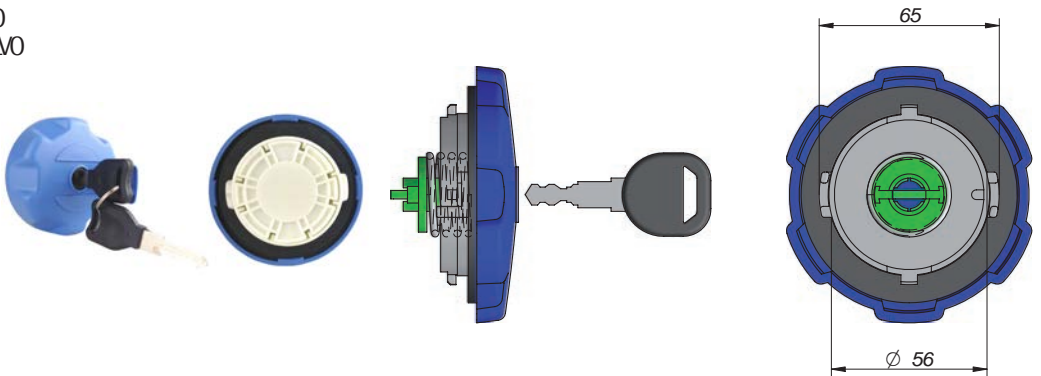

Tank Cap AdBlue Ø60 FORD CARGO EURO5-IVECO-SCANIA
Tankdeckel AdBlue Ø60 FORD CARGO EURO5-IVECO-SCANIA
Tapón AdBlue Ø60 FORD CARGO EURO5-IVECO-SCANIA

Ref	Kg	Ø	Key Llave	Lot
6702052	0.248	60		1

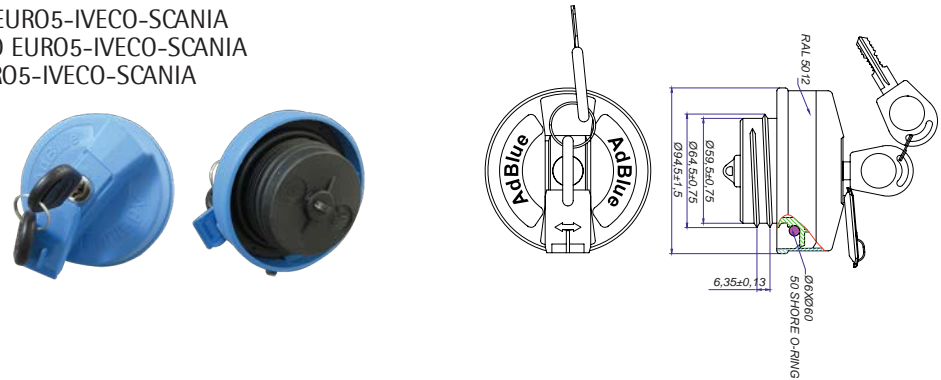

Tank Cap AdBlue Ø40 MERCEDES-MAN-DAF-SCANIA
Tankdeckel AdBlue Ø40 MERCEDES-MAN-DAF-SCANIA
Tapón AdBlue Ø40 MERCEDES-MAN-DAF-SCANIA

Ref	Kg	Ø	Lot
6702054	0.102	40	1

No vented
No ventilado

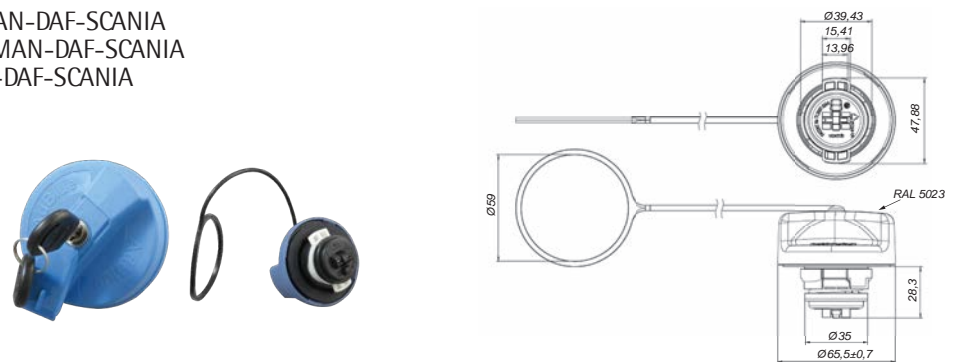

Tank Cap AdBlue Ø60 FORD CARGO EURO5-IVECO-SCANIA
Tankdeckel AdBlue Ø60 FORD CARGO EURO5-IVECO-SCANIA
Tapón AdBlue Ø60 FORD CARGO EURO5-IVECO-SCANIA

Ref	Kg	Ø	Lot
6702056	0.206	60	1

Vented
Ventilado

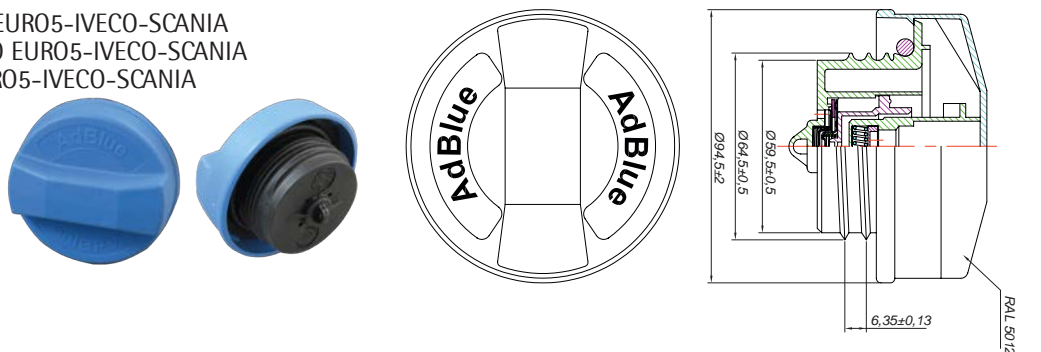

ANTITHEFT REAR DOORS / ANTIDIEBSTAHL HINTERTÜR / ANTIROBO CIERRES TRASEROS



SAFETY AND ANTI-THEFT SYSTEMS / SICHERHEIT UND DIEBSTAHLSICHERUNGEN / SEGURIDAD Y ANTIROBOS

Antitheft Blockading System Steel Coated Black
 Antidiebstahl-Containerverriegelung Stahl Schwarz
 Antirrobo Cierre Trasero Pintado Negro

Ref	Kg	Mat	Sup/Finish Acabado	Col	Article	Key Llave	Lot
7205008	2.33	STEEL			Key with different serial number Llave con distinto nº de serie		1
7205009	2.33	STEEL			Key with the same serial number Llave con mismo nº de serie		1

min: 220 mm - min: 420 mm. | Reinforced Steel | 3 keys
 min: 220 mm - máx: 420 mm. | Acero reforzado | 3 Llaves

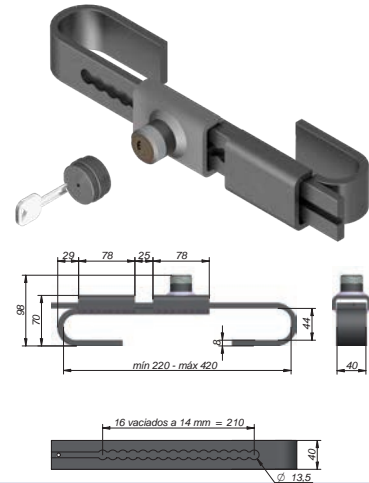

Antitheft Blockading System
 Antidiebstahl-Containerverriegelung
 Antirrobo Cierre Trasero

Ref	Kg	Mat	Lot
7205012	1.8	INOX	1

min: 239 mm - max: 300 mm. | 3 keys
 min: 239 mm - máx: 300 mm. | 3 Llaves

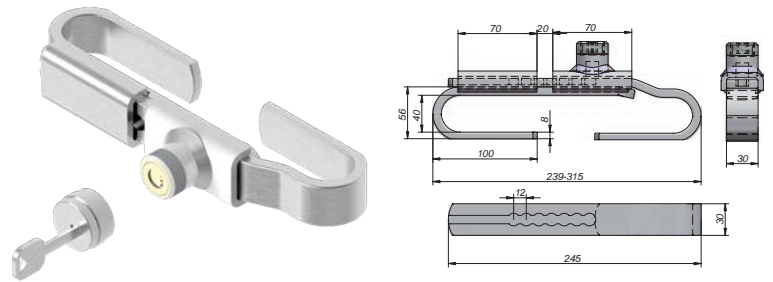

Antitheft Blockading System Stainless Steel
 Antidiebstahl-Containerverriegelung Edelstahl
 Antirrobo Cierre Trasero Inox

Ref	Kg	Mat	Article	Key Llave	Lot
7205014	2.23	INOX	Key with different serial number Llave con distinto nº de serie		1
7205015	2.23	INOX	Key with the same serial number Llave con mismo nº de serie		1

min: 240 mm - max: 330 mm. | 3 keys
 min: 240 mm - máx: 330 mm. | 3 Llaves

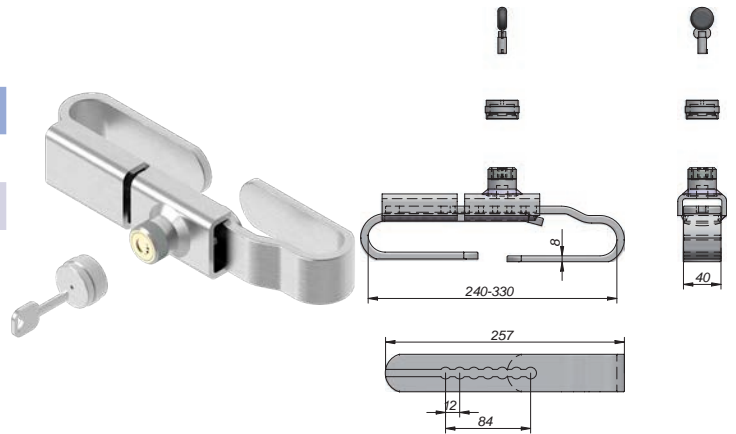

Antitheft Blockading System Container
 Antidiebstahl-Containerverriegelung Edelstahl
 Antirrobo Cierre Trasero Contenedor

Ref	Kg	Mat	Key Llave	Lot
7205021	2.32	INOX		1

min: 265 mm - max: 435 mm. | 3 keys
 min: 265 mm - máx: 435 mm. | 3 Llaves

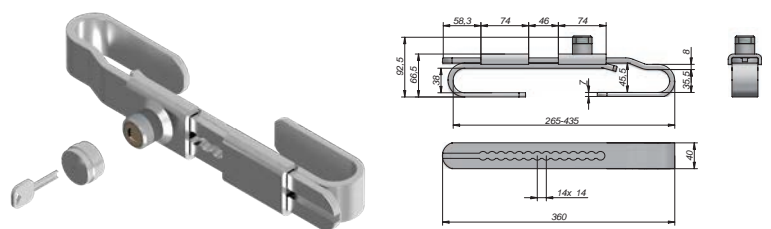



ANTITHEFT REAR DOORS / ANTIDIEBSTAHL HINTERTÜR / ANTIRROBO CIERRES TRASEROS

SAFETY AND ANTI-THEFT SYSTEMS / SICHERHEIT UND DIEBSTAHLSICHERUNGEN / SEGURIDAD Y ANTIRROBOS

Antitheft Lock Cylinder
Schlusszylinder Antidiebstahl Blockier System
Bombín para Antirrobo Cierre Trasero

Ref	Kg	Mat	Key Llave	Lot
7290001	0.076	INOX		1



Security Lock for Rear Doors
Sicherheitsschloss für Hintertüren
Cierre de Seguridad Aluminio para Puertas Traseras

NEW

Ref	Kg	Mat	Pos	Key Llave	Lot
7205019	0.467				1

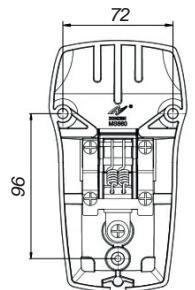
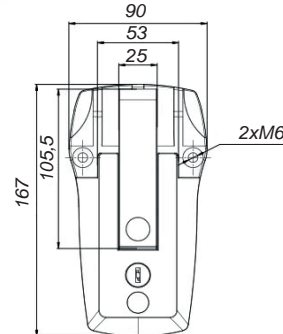
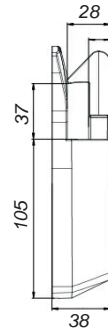
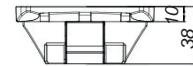



King Pin Antitheft Device Big Base
King Pin Antidiebstahl mit Boden
Antirrobo King Pin Plato Grande

Ref	Kg	Mat	Sup/Finish Acabado	Col	Key Llave	Lot
2572010	3.9	STEEL				1

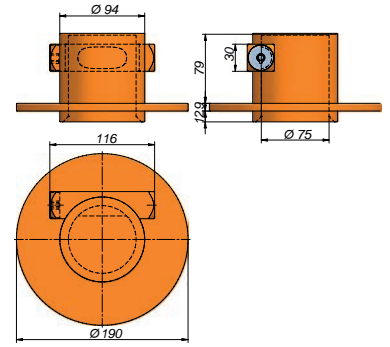
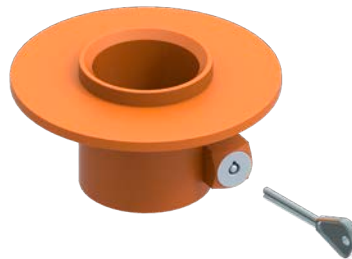

King Pin Antitheft w/Handle Orange
Diebstahlsicherung für Königszapfen m/Griff Orange
Antirrobo King Pin c/Manilla

Ref	Kg	Mat	Sup/Finish Acabado	Col	Key Llave	Lot
2572001	3	STEEL				1

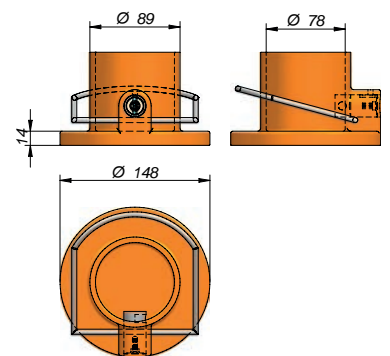
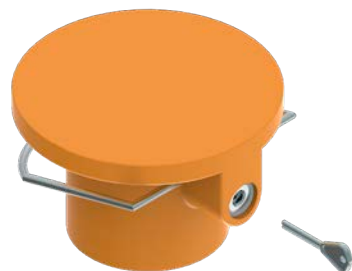

King Pin Aluminium Antitheft
Diebstahlsicherung für Königszapfen Aluminium
Antirrobo King Pin Aluminio

Ref	Kg	Mat	Key Llave	Lot
2572002	1.2			1

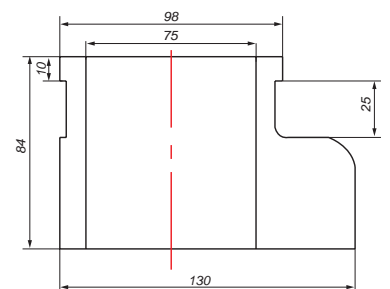

Universal 5Th Wheel Coupling Cover
Universal 5Th Wheel Coupling Cover
Cubierta 5ª Rueda Universal

NEW

Ref	Kg	Mat	Col	Article	Lot
6504540	4	ABS		L1000x900Wx80H mm.	1

Made from UV-proof ABS | White Colour RAL9010 | Can be easily painted in vehicle color
Plástico ABS alto impacto (protección UV) | Color Blanco RAL9010 |
Puede ser pintada en el color del vehículo





SAFETY AND ANTI-THEFT SYSTEMS / SICHERHEIT UND DIEBSTAHLSICHERUNGEN / SEGURIDAD Y ANTIRROBOS



SECURITY LOCKS CIERRES DE SEGURIDAD



SATURN EVO	NOVAL	BLACKSTONE
INSTALLERS AND FREELANCERS INSTALADORES Y AUTÓNOMOS	POST OFFICE AND FREIGHT CORREOS Y FLETES	SLAM: POST OFFICE AND FREIGHT CORREOS Y FLETES COMBO: INSTALLERS AND FREELANCERS INSTALADORES Y AUTÓNOMOS
		
<p>It is fixed to the door without the driver needing to release the bushing.</p> <p>Adaptable to any model of van. Slotted holes (greater mounting flexibility).</p> <p><i>Queda fijado a la puerta sin necesidad de que el conductor libere el casquillo.</i></p> <p><i>Adaptable a cualquier modelo de furgoneta. Agujeros ranurados (mayor flexibilidad montaje).</i></p>	<p>If the user needs the door to be constantly closed, they do not have to worry about whether the lock is activated or not. Once the key is removed, it locks automatically.</p> <p><i>Si el usuario tiene la necesidad de que la puerta esté constantemente cerrada, no tiene que preocuparse de si la cerradura está activada o no. Una vez extraída la llave, la cerradura se bloquea automáticamente.</i></p>	<p>SLAM: automatic door closing</p> <p>COMBO: two ON/OFF lock options:</p> <ol style="list-style-type: none"> 1. The lock is activated every time the doors are closed. 2. Lock disabled so you don't have to use the key every time the door is opened. <p><i>SLAM: fermeture automatique des portes.</i></p> <p><i>COMBO: deux options de verrouillage ON/OFF:</i></p> <ol style="list-style-type: none"> 1. activer le verrouillage à chaque fois qu'ils ferment les portes ou avec. 2. verrouillage désactivé pour ne pas avoir à utiliser la clé chaque fois que la porte est ouverte.

Antitheft Door Lock "Noval"
Tür-Diebstahlsicherung "Noval"
Cierre Antirrobo Puerta Furgón "Noval"

Ref	Kg	Mat	Article	Key Llave	Lot
2572004	1	INOX	Position: Side or Back Posición: Lateral o Trasero		1
2572025	2	INOX	Kit 2 units Position: Side and Back Kit 2 unidades Posición: Lateral y Trasero		1

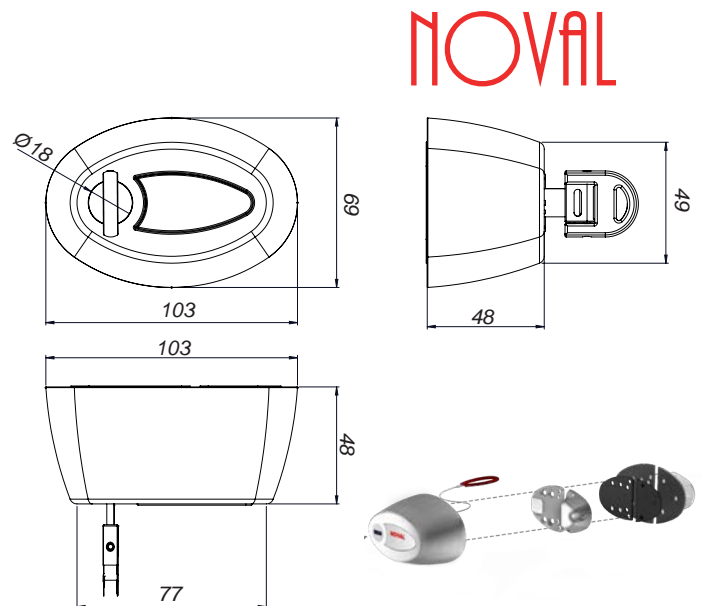

- 304 Stainless Steel
- Satin with sticker.
- 103x69x48mm. / 1.2 Kg.
- "SLAM" automatic locking system when closing the door
- Interior opening with cable
- Assembly: 30 min.
- Test: 100,000 open-close cycles

- Acero INOX 304
- Satinado con pegatina.
- 103x69x48 mm. / 1,2 Kg.
- Sistema de bloqueo automático "SLAM" al cerrar la puerta
- Apertura interior con cable
- Montaje: 30 min.
- Test: 100.000 ciclos apertura-cierre



Antitheft Door Lock "Saturn Evo"
 Tür-Diebstahlsicherung "Saturn Evo"
 Cierre Antirrobo Puerta "Saturn Evo"

Ref	Kg	Mat	Article	Llave Con Llave	Lot
2572008	1.2	INOX	Back Trasero		1
2572009	2.3	INOX	Kit 2 units Side/Back Kit 2 uds Lateral/Trasero		1

SATURN EVO

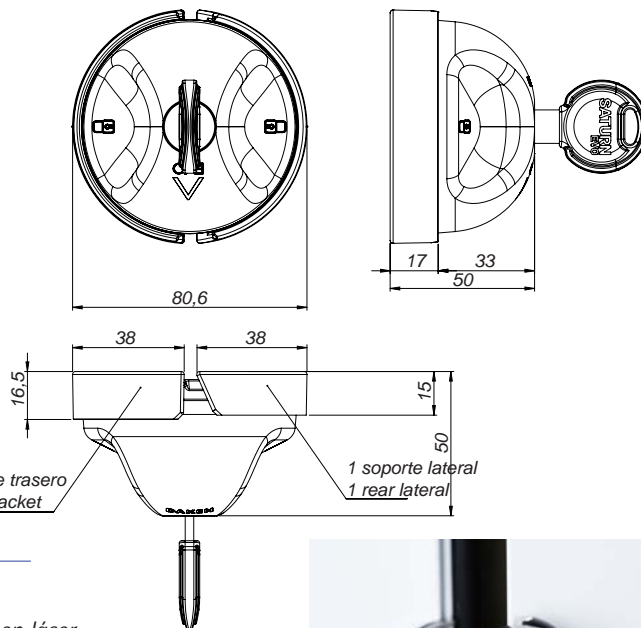

1 soporte trasero
1 rear bracket

1 soporte lateral
1 rear lateral

- 304 Stainless Steel
 - Satin - Laser engraved
 - 80x80x49mm. / 0.9 kg.
 - Manual locking system
 - Manual emergency interior opening
 - Assembly: 20 min.
 - Test: 52,000 open/close cycles
- Acero INOX 304
 - Satinado - Grabado en láser
 - 80x80x49 mm. / 0,9 Kg.
 - Sistema de bloqueo manual
 - Apertura interior de emergencia manual
 - Montaje: 20 min.
 - Test: 52.000 ciclos apertura-cierre



Antitheft Door Lock "Blackstone"
 Tür-Diebstahlsicherung "Blackstone"
 Cierre Antirrobo Puerta "Blackstone"

NEW

Ref	Kg	Mat	Article	Key Llave	Lot
2572012	1.6	INOX	SLAM (Automatic Lock) SLAM (cierre automático)		1
2572013	3.2	INOX	Kit 2 units SLAM (Automatic Lock) Kit 2 uds SLAM (cierre automático)		1
2572015	1.6	INOX	COMBO (Manual Lock) COMBO (cierre manual)		1
2572016	3.2	INOX	Kit 2 units COMBO (Manual Lock) Kit 2 uds COMBO (cierre manual)		1

BLACKSTONE

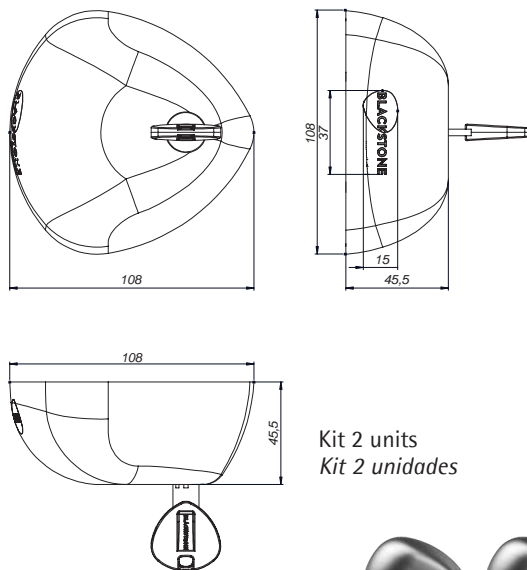
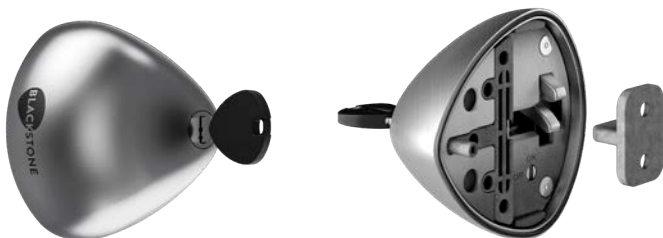

Kit 2 units
Kit 2 unidades

- 304 Stainless Steel
 - Satin - Laser engraving
 - 105x105x45mm. / 1.6 Kg.
 - Automatic "SLAM" or manual "COMBO" locking system
 - Interior opening with lever
 - Assembly: 30 min.
 - Test: 52,000 open-close cycles
- Acero INOX 304
 - Satinado - Grabado láser
 - 105x105x45 mm. / 1,6 Kg.
 - Sistema de bloqueo automático "SLAM" o manual "COMBO"
 - Apertura interior con palanca
 - Montaje: 30 min.
 - Test: 52.000 ciclos apertura-cierre

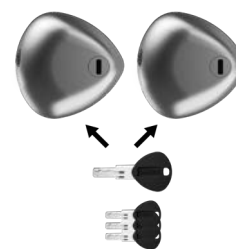

SAFETY AND ANTI-THEFT SYSTEMS / SICHERHEIT UND DIEBSTAHLSICHERUNGEN / SEGURIDAD Y ANTIRROBOS



CABINE ANTITHEFT / ANTIDIEBSTAHL VAN / ANTIRROBO DE CABINA

SAFETY AND ANTI-THEFT SYSTEMS / SICHERHEIT UND DIEBSTAHLSICHERUNGEN / SEGURIDAD Y ANTIRROBOS

Interior Security Lock RENAULT MAGNUM 2010
Diebstahlsicherung Kabinen RENAULT MAGNUM 2010
Antirrobo Interior Cabina RENAULT MAGNUM 2010

Ref	Kg	Lot
7205032	0.12	1

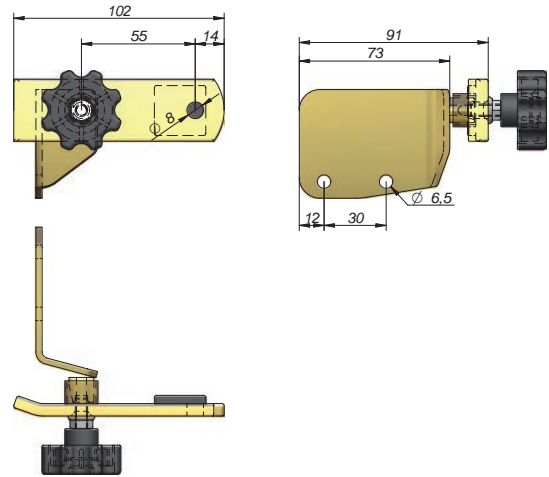
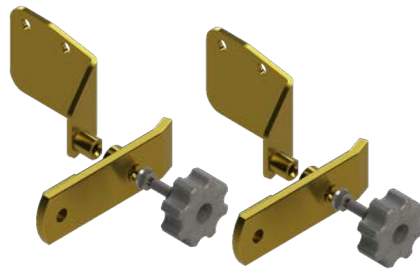

Interior Security Lock RENAULT-T
Diebstahlsicherung Kabinen RENAULT-T
Antirrobo Interior Cabina RENAULT-T

Ref	Kg	Lot
7205033	0.12	1

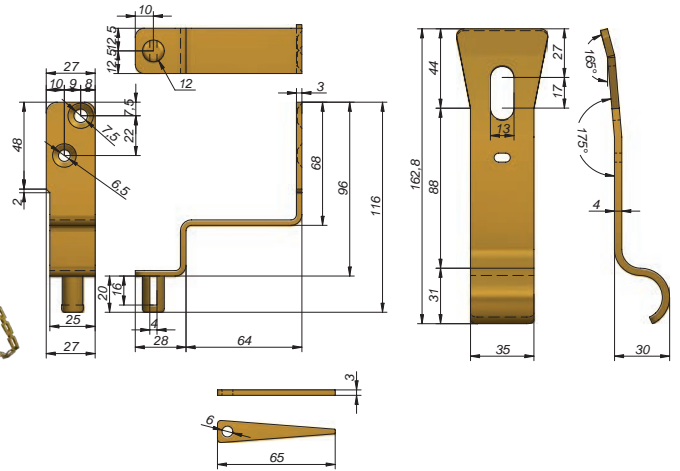

Interior Security Lock RENAULT PREMIUM
Diebstahlsicherung Kabinen RENAULT PREMIUM
Antirrobo Interior Cabina RENAULT PREMIUM

Ref	Kg	Lot
7205034	0.12	1

Fixing screws included
Incluye tornillos de fijación

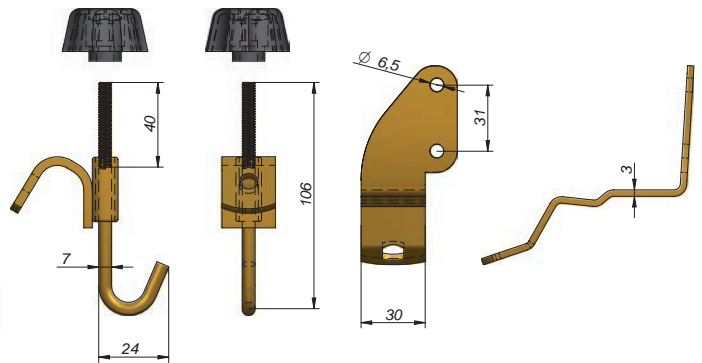

Interior Security Lock MERCEDES ACTROS
Diebstahlsicherung Kabinen MERCEDES ACTROS
Antirrobo Interior Cabina MERCEDES ACTROS

Ref	Kg	Lot
7205036	0.12	1

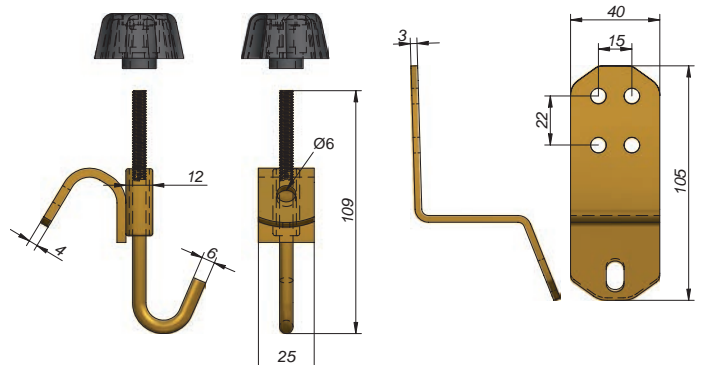

Interior Security Lock MERCEDES ACTROS 4
 Diebstahlsicherung Kabinen MERCEDES ACTROS 4
 Antirrobo Interior Cabina MERCEDES ACTROS 4

Ref	Kg	Lot
7205037	0.12	1

Fixing screws included
 Incluye tornillos de fijación

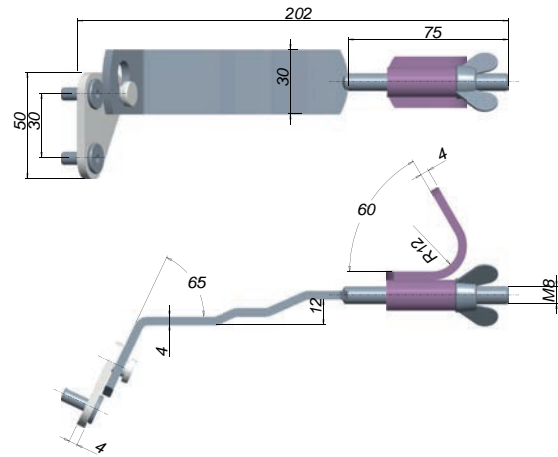
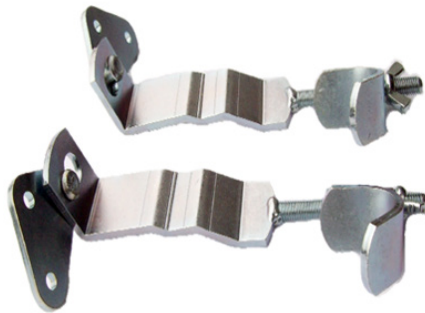

Interior Security Lock IVECO STRALIS
 Diebstahlsicherung Kabinen IVECO STRALIS
 Antirrobo Interior Cabina IVECO STRALIS

Ref	Kg	Sup/Finish Acabado	Lot
7205038	0.64	Zn	1

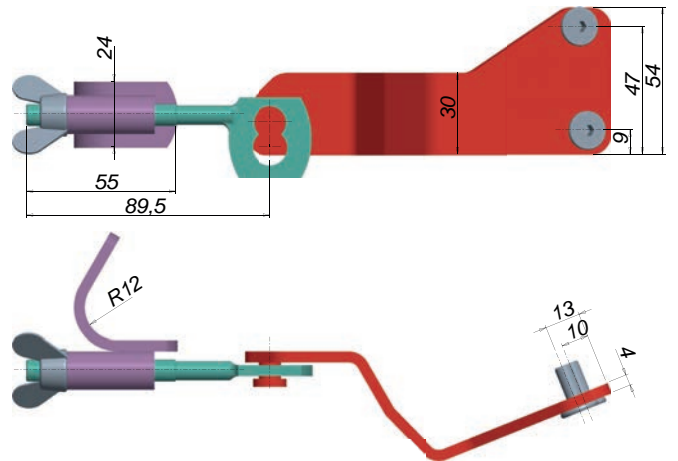

Interior Security Lock SCANIA
 Diebstahlsicherung Kabinen SCANIA
 Antirrobo Interior Cabina SCANIA

Ref	Kg	Lot
7205040	0.12	1

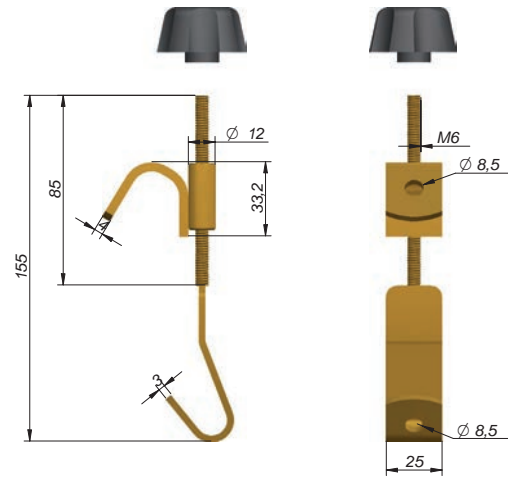

Interior Security Lock VOLVO FH/FH4/FH6
 Diebstahlsicherung Kabinen VOLVO FH/FH4/FH6
 Antirrobo Interior Cabina VOLVO FH/FH4/FH6

Ref	Kg	Sup/Finish Acabado	Lot
7205042	0.38	Zn	1

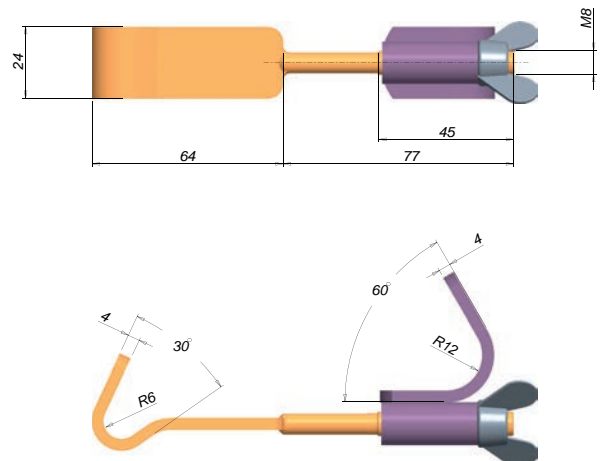

SAFETY AND ANTI-THEFT SYSTEMS / SICHERHEIT UND DIEBSTAHLSICHERUNGEN / SEGURIDAD Y ANTIRROBOS



CABINE ANTITHEFT / ANTIDIEBSTAHL VAN / ANTIRROBO DE CABINA

SAFETY AND ANTI-THEFT SYSTEMS / SICHERHEIT UND DIEBSTAHLSICHERUNGEN / SEGURIDAD Y ANTIRROBOS

Interior Security Lock DAF XF-95
Diebstahlsicherung Kabinen DAF XF-95
Antirrobo Interior Cabina DAF XF-95

Ref	Kg	Lot
7205045	0.12	1

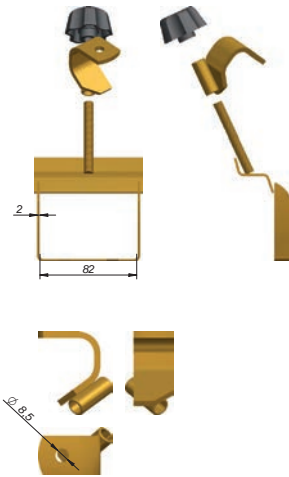

Interior Security Lock MAN TGA-TGL-TGX-TGK
Diebstahlsicherung Kabinen MAN TGA-TGL-TGX-TGK
Antirrobo Interior Cabina MAN TGA-TGL-TGX-TGK

Ref	Kg	Sup/Finish Acabado	Lot
7205046	0.54	Zn	1

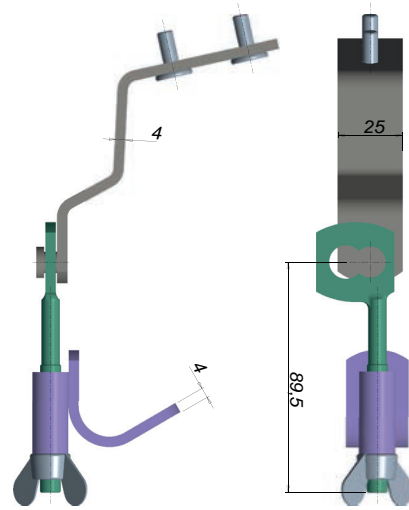

Accesorios Cabina
Cabin Accessories
Accessoires Cabine
Kabinenzubehör
Acessório De Cabine

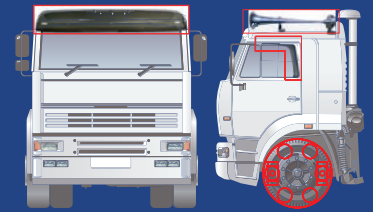

Accesorios Furgoneta
Van Accessories
 Accessoires Utilitaires
Van-Zubehör
 Acessórios Para Furgões



pag. 424-429

Cubiertas de Rueda
Mudguard Cover
 Passage De Roue
Kotflügelabdeckung
 Cava De Roda



pag. 430-432

Viseras
Sun Visors
 Visières
Sonnenblenden
 Viseiras



pag. 433-445

Derivabrisas
Wind Deflectors
 Déflecteur
Windabweiser
 Paravento



pag. 446-449

Deflectores
Deflectors
 Déflecteurs
Deflektoren
 Defletores



pag. 450-452

Tapacubos
Wheel Caps
 Enjoliveurs
Radkappen
 Tampões



pag. 453-457

Bocinas
Horns
 Klaxons
Fanfaren
 Bozinas



pag. 458

Accesorios Varios
Other Accessories
 Accessoires Variés
Sonstiges Zubehör
 Acessórios Vários



pag. 459-462



VAN Accessories

Black Plastic Carrying Tube
Transportrohr Kunststoff Schwarz
Tubo de Transporte Redondo en Plástico

NEW

Ref	Kg	Mat	Col	A	B	C	Ø	Thickn. Espesor	Article	Lot
0201060	8.51		●	3080	190	192	Ø160	4	tube 78x15	1
0201062	10.55		●	4080	190	192	Ø160	4	tube 78x15	1
0201064	12.05		●	3080	230	232	Ø200	4.9	tube 123x15	1
0201068	15.1		●	4080	230	232	Ø200	4.9	tube 123x15	1

Scratch resistant | Installation time: 20 minutes | Security lock system | Customizable colors and logos
Resistente a los arañazos | Tiempo de instalación: 20 minutos | Sistema de cierre de seguridad | Colores y logos personalizables

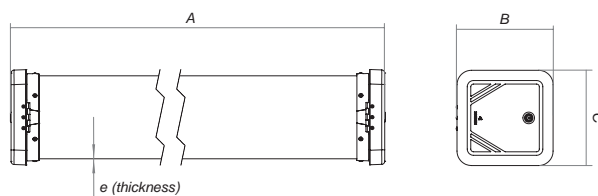

Aluminium Carrying Tube
Transportrohr Aluminium
Tubo de Transporte Redondo en Aluminio

NEW

Ref	Kg	Mat	A	B	C	Ø	Thickn. Espesor	Article	Lot
0201070	10.56		3080	190	192	Ø160	2	tube 79x15	1
0201072	13.24		4080	190	192	Ø160	2	tube 79x15	1
0201074	15.46		3080	230	232	Ø200	2.5	tube 130x15	1
0201078	19.65		4080	230	232	Ø200	2.5	tube 130x15	1

Scratch resistant | Installation time: 20 minutes | Security lock system | Customizable colors and logos
Resistente a los arañazos | Tiempo de instalación: 20 minutos | Sistema de cierre de seguridad | Colores y logos personalizables

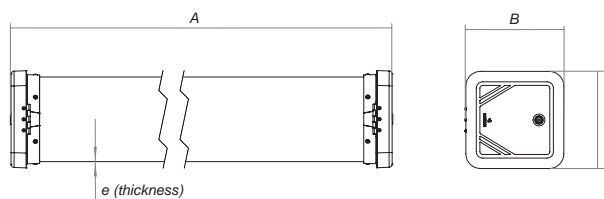

Fitting Kit for Round Carrying Tube
Montagekit für Transportrohr
Kit de Montaje para Tubo de Transporte Redondo

NEW

Ref	Kg	A	B	Ø	Lot
0201080	1.62	205	213	Ø160	1
0201082	1.74	245	253	Ø200	1

Installation time: 20 minutes
Tiempo de instalación: 20 minutos

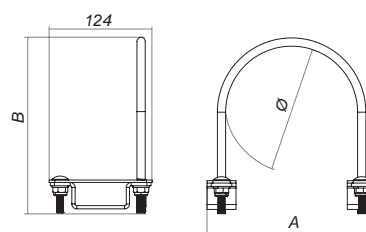

Square Carrying Aluminium Tube
 Quadratisch Transportrohr Aluminium
 Tubo de Transporte Cuadrado en Aluminio

Ref	Kg	Mat	A	B	C	Thickn. Espesor	Article	Lot
0201050	21.28	Al	3300	250	179	2	tube 108x15	1
0201052	27.71	Al	4300	250	179	2	tube 108x15	1
0201054	13.5	Al	3300	170	179	2	tubes 66x15	1
0201056	19.5	Al	4300	170	179	2	tubes 66x15	1

Waterproof | Scratch resistant | Installation time: 20 minutes | Security lock system |
 Anticrushing system | Customizable colors and logos
 Impermeable | Resistente a los arañazos | Tiempo de instalación: 20 min. | Sistema cierre seguridad |
 Sistema anti-atrapamiento manos | Personalizable

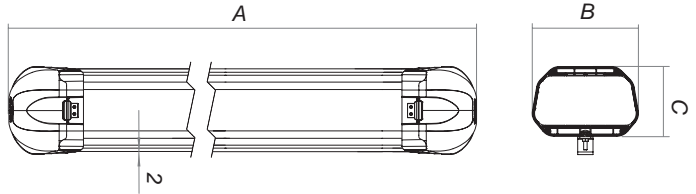

Carrying Tube Fitting Kit
 Montagekit für Quadratischen Transportohres
 Kit de montaje para tubo de transporte cuadrado

Ref	Kg	Lot
0201057	1.5	1

Installation time: 20 minutes
 Tiempo de instalación: 20 minutos

NEW

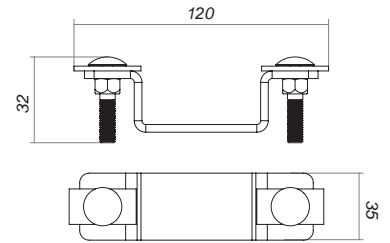

Carrying Square Tube Separator
 Separator des Quadratischen Transportohres
 Separador para Tubo de Transporte Cuadrado

Ref	Kg	A	Lot
0201058	2.5	3300	1
0201059	3.5	4000	1

Installation time: 20 minutes
 Tiempo de instalación: 20 minutos

NEW

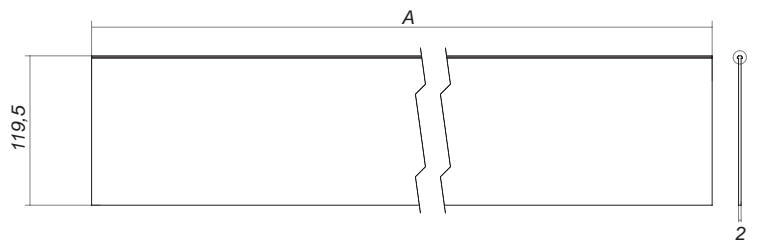

CABIN ACCESSORIES / KABINENZUBEHÖR / ACCESORIOS CABINA





VAN ACCESSORIES / VAN-ZUBEHÖR / ACCESORIOS FURGONETA

CABIN ACCESSORIES / KABINENZUBEHÖR / ACCESORIOS CABINA

Footboard for Van with towing hook Triple Black
Trittbrett für Van mit Anhängervorrichtung - 3-fach - Schwarz
Estribo Furgoneta c/bola de Remolque Triple Negro

NEW

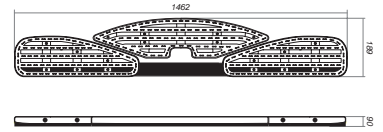

Ref	Kg	Col	Lot
1903032	15		1

TUV Approved | Installation time: 20 minutos | Maximum Load: 136 kg. | Anti-slip Surface |
Towing angle: 110° | Optional sensors
TUV Approved | Tiempo de instalación: 20 minutos | Carga máxima: 136 kg. | Superficie antislip |
Ángulo de remolque: 110° | Sensores opcionales



Footboard for Van with towing hook Triple Yellow
Trittbrett für Van mit Anhängervorrichtung - 3-fach - Gelb
Estribo Furgoneta c/bola de Remolque Triple Amarillo

NEW

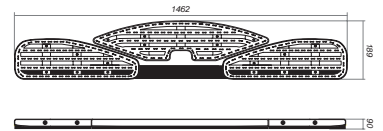

Ref	Kg	Col	Lot
1903034	15		1

TUV Approved | Installation time: 20 minutos | Maximum Load: 136 kg. | Anti-slip Surface |
Towing angle: 110° | Optional sensors
TUV Approved | Tiempo de instalación: 20 minutos | Carga máxima: 136 kg. | Superficie antislip |
Ángulo de remolque: 110° | Sensores opcionales



Footboard for Van with towing hook Double Black
Trittbrett für Van mit Anhängervorrichtung - 2-fach - Schwarz
Estribo Furgoneta c/bola de Remolque Doble Negro

NEW

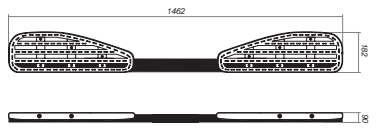

Ref	Kg	Col	Lot
1903022	11.4		1

TUV Approved | Installation time: 20 minutos | Maximum Load: 136 kg. | Anti-slip Surface |
Towing angle: 110° | Optional sensors
TUV Approved | Tiempo de instalación: 20 minutos | Carga máxima: 136 kg. | Superficie antislip |
Ángulo de remolque: 110° | Sensores opcionales



Footboard for Van with towing hook Double Yellow
Trittbrett für Van mit Anhängervorrichtung - 2-fach - Gelb
Estribo Furgoneta c/bola de Remolque Doble Amarillo

NEW

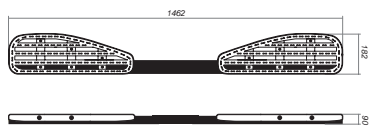

Ref	Kg	Col	Lot
1903024	11.4		1

TUV Approved | Installation time: 20 minutos | Maximum Load: 136 kg. | Anti-slip Surface |
Towing angle: 110° | Optional sensors
TUV Approved | Tiempo de instalación: 20 minutos | Carga máxima: 136 kg. | Superficie antislip |
Ángulo de remolque: 110° | Sensores opcionales





Footboard for Van Double Black
Trittbrett für Van - 2-fach - Schwarz
Estribo Furgoneta Doble Negro

Ref	Kg	Col	Lot
1903002	9.5		1

TUV Approved | Installation time: 20 minutes | Maximum Load: 136 kg. | Anti-slip Surface | Optional sensors
TUV Approved | Tiempo de instalación: 20 minutos | Carga máxima: 136 kg. | Superficie antislip | Sensores opcionales

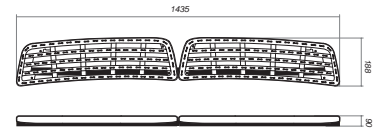

Footboard for Van Double Yellow
Trittbrett für Van - 2-fach - Gelb
Estribo Furgoneta Doble Amarillo

Ref	Kg	Col	Lot
1903004	9.5		1

TUV Approved | Installation time: 20 minutes | Maximum Load: 136 kg. | Anti-slip Surface | Optional sensors
TUV Approved | Tiempo de instalación: 20 minutos | Carga máxima: 136 kg. | Superficie antislip | Sensores opcionales

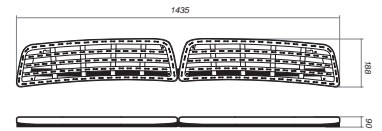

Footboard for Van Triple Black
Trittbrett für Van - 3-fach - Schwarz
Estribo Furgoneta Triple Negro

Ref	Kg	Col	Lot
1903012	11		1

TUV Approved | Installation time: 20 minutes | Maximum Load: 136 kg. | Anti-slip Surface | Optional sensors
TUV Approved | Tiempo de instalación: 20 minutos | Carga máxima: 136 kg. | Superficie antislip | Sensores opcionales

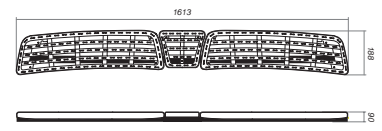

Footboard for Van Triple Yellow
Trittbrett für Van - 3-fach - Gelb
Estribo Furgoneta Triple Amarillo

Ref	Kg	Col	Lot
1903014	11		1

TUV Approved | Installation time: 20 minutos | Maximum Load: 136 kg. | Anti-slip Surface | Optional sensors
TUV Approved | Tiempo de instalación: 20 minutos | Carga máxima: 136 kg. | Superficie antislip | Sensores opcionales

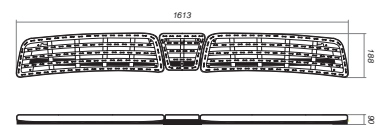

Fitting Kit for Van Footboard
Montagekit Trittbrett für Van
Kit de Montaje de Estribo para Furgoneta

NEW

Ref	Kg	A	B	C	Article	Lot
1903100	4.46	245	224	145	CITROEN Jumper 2006 - FIAT Ducato 2006 - PEUGEOT Boxer 2006 - OPEL Movano 2021 -	1
1903110	8.27	446.5	81.5	218.75	NISSAN NV400/Interstar RENAULT Master 2010 - OPEL Movano 2010-2021	1
1903111	5.73	379	130.2	164.4	FIAT Talento 2016-2021 NISSAN NV300/Primastar RENAULT Trafic 2014 - OPEL Vivaro 2014-2019	1
1903120	4.86	235.3	150	228.6	VOLKSWAGEN T5 2002-2015 / T6 2015 -	1
1903130	7.8	539	25	253	VOLKSWAGEN Crafter 2017 -	1
1903200	7.45	507	51.5	306	CITROEN Jumpy 2016 - FIAT Scudo 2022 - PEUGEOT Expert 2016 - OPEL Vivaro 2019 - TOYOTA ProAce 2016 -	1
1903300	4.3	284.6	97.1	279.4	FIAT Doblo 2012 - OPEL Combo 2012-2018	1
1903400	8.15	518.44	10	264.63	FORD Transit Custom 2012 -	1
1903500	4.57	410.87	168	236.75	FORD Transit Connect 2014 -	1
1903600	11.15	662	8	287.5	FORD Transit 2014 -	1
1903700	6.91	475	59.5	202	IVECO Daily 1999-2014 IVECO Daily 2014 -	1
1903800	6.5	402	8	310	MERCEDES Sprinter 2006 - VOLKSWAGEN Crafter 2006 - 2017	1
1903900	7.66	402	30.8	343	MERCEDES Sprinter MWB Twin Wheel 2006 - VOLKSWAGEN Crafter MWB Twin Wheel 2006 - 2017	1

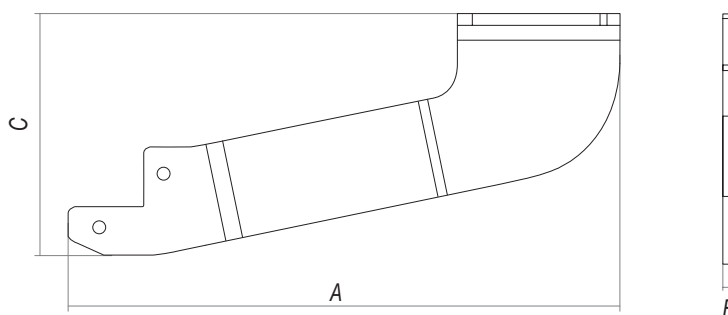

Ladder clamp for Van
Leiterklemme für Van
Percha de Escalera para Furgoneta

NEW

Ref	Kg	Lot
7002030	2.8	1

TUV Approved | Manufactured with tough composite materials |
Fitting Time: 2 minutes | Up to 3 ladder tier section
TUV Approved | Materiales Composites - Resistencia a corrosión |
Tiempo de instalación: 2 minutos | Hasta 3 tramos de escaleras

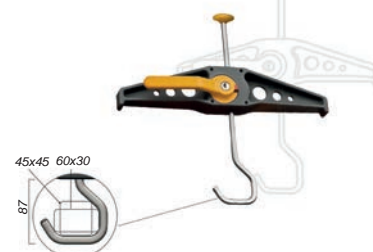
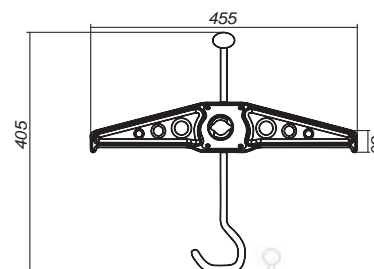

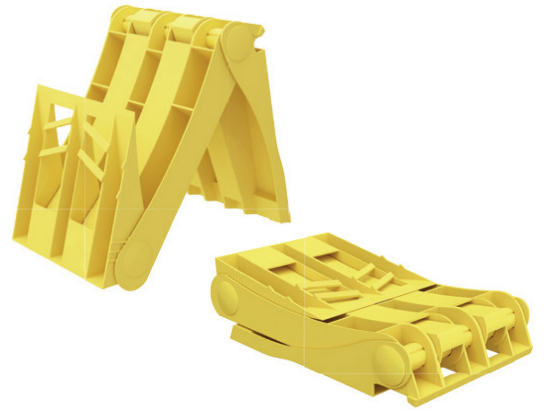

Folding Chock R360 DIN 76051
 Radkeil Klappbar R360 DIN 76051
 Calzo Rueda Plegable R360 DIN 76051

NEW

Ref	Kg	Mat	Col	Lot
1102150	0.32	PP	Yellow	1

With metal insert | Maximum Load: 1.600 Kg.
 Con inserto metálico | Carga máxima: 1.600 Kg.

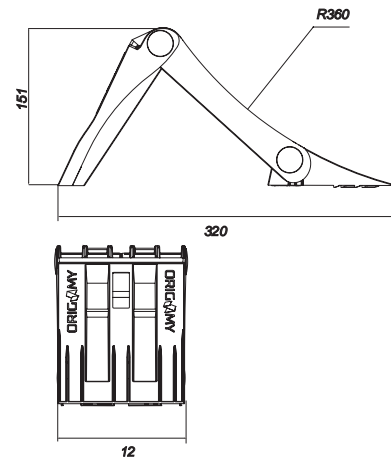

Simple Fixing Support for 1102150 Wheel Chock
 Hemmschuh-Halter, 1-fach für 1102150 Hemmschuhe
 Soporte de Fijación Simple p/Calzo 1102150

NEW

Ref	Kg	Mat	Col	Lot
1102154	0.04	PP	Black	1

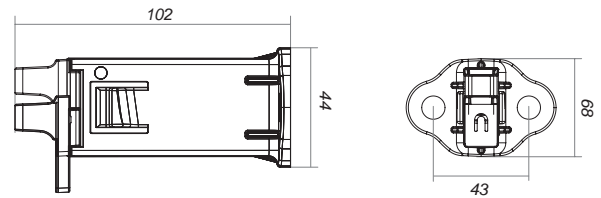

Double Fixing Support for 1102150 Wheel Chock
 Hemmschuh-Halter, 2-fach für 1102150 Hemmschuhe
 Soporte de Fijación Doble p/Calzo 1102150

NEW

Ref	Kg	Mat	Lot
1102156	0.05	PP	1

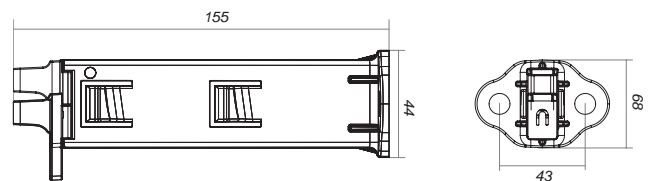

MUDGUARD COVER / KOTFLÜGELABDECKUNG / CUBIERTAS DE RUEDA

CABIN ACCESSORIES / KABINENZUBEHÖR / ACCESORIOS CABINA

BERLINGO/COMBO/PARTNER/PROACE CITY K9 L1

NEW



Ref	Kg	Mat	Article	Lot
6504001	1.4	ABS		1

High Impact ABS plastic and UV protected | Covers your vehicles mudguard from pallets and loaded goods | Easy to mount on new or used vehicle
Plástico ABS alto impacto (protección UV) | Protege el guardabarros de palés y mercancías cargadas | Fácil de montar en vehículos nuevos o usados

BERLINGO/COMBO/PARTNER/PROACE CITY K9 L2

NEW



Ref	Kg	Mat	Article	Lot
6504002	1.4	ABS		1

High Impact ABS plastic and UV protected | Covers your vehicles mudguard from pallets and loaded goods | Easy to mount on new or used vehicle
Plástico ABS alto impacto (protección UV) | Protege el guardabarros de palés y mercancías cargadas | Fácil de montar en vehículos nuevos o usados

FORD TRANSIT RWD/AWD 05/2014-

NEW



Ref	Kg	Mat	Article	Lot
6504003	1.8	ABS		1

High Impact ABS plastic and UV protected | Covers your vehicles mudguard from pallets and loaded goods | Easy to mount on new or used vehicle
Plástico ABS alto impacto (protección UV) | Protege el guardabarros de palés y mercancías cargadas | Fácil de montar en vehículos nuevos o usados

FORD TRANSIT RWD/AWD 05/2014-

NEW



Ref	Kg	Mat	Article	Lot
6504004	2.9	ABS		1

High Impact ABS plastic and UV protected | Covers your vehicles mudguard from pallets and loaded goods | Easy to mount on new or used vehicle
Plástico ABS alto impacto (protección UV) | Protege el guardabarros de palés y mercancías cargadas | Fácil de montar en vehículos nuevos o usados

MB CITAN/ NISSAN TOWNSTAR/RENAULT KANGOO 2022- L1

NEW



Ref	Kg	Mat	Article	Lot
6504005	2.2	ABS		1

High Impact ABS plastic and UV protected | Covers your vehicles mudguard from pallets and loaded goods | Easy to mount on new or used vehicle
Plástico ABS alto impacto (protección UV) | Protege el guardabarros de palés y mercancías cargadas | Fácil de montar en vehículos nuevos o usados

M-B SPRINTER 06/2018- FWD

NEW



Ref	Kg	Mat	Article	Lot
6504006	2.6	ABS		1

High Impact ABS plastic and UV protected | Covers your vehicles mudguard from pallets and loaded goods | Easy to mount on new or used vehicle
Plástico ABS alto impacto (protección UV) | Protege el guardabarros de palés y mercancías cargadas | Fácil de montar en vehículos nuevos o usados

M-B SPRINTER ELECTRIC 11/2020- FWD

NEW



Ref	Kg	Mat	Article	Lot
6504007	2.6	ABS		1

High Impact ABS plastic and UV protected | Covers your vehicles mudguard from pallets and loaded goods | Easy to mount on new or used vehicle
Plástico ABS alto impacto (protección UV) | Protege el guardabarros de palés y mercancías cargadas | Fácil de montar en vehículos nuevos o usados

Sprinter 2006-, 2013- and 6/2018 - rwd / 4wd / Vw Crafter -05/2017

NEW



Ref	Kg	Mat	Article	Lot
6504008	2.2	ABS		1

High Impact ABS plastic and UV protected | Covers your vehicles mudguard from pallets and loaded goods | Easy to mount on new or used vehicle
Plástico ABS alto impacto (protección UV) | Protege el guardabarros de palés y mercancías cargadas | Fácil de montar en vehículos nuevos o usados

Sprinter M-B SPRINTER TWIN WHEEL NCV3/06/2018

NEW



Ref	Kg	Mat	Article	Lot
6504009	3.1	ABS		1

High Impact ABS plastic and UV protected | Covers your vehicles mudguard from pallets and loaded goods | Easy to mount on new or used vehicle
Plástico ABS alto impacto (protección UV) | Protege el guardabarros de palés y mercancías cargadas | Fácil de montar en vehículos nuevos o usados

Sprinter M-B VITO/VIANO 2003-2014/ VITO 2014- / V-Class 2014-

NEW



Ref	Kg	Mat	Article	Lot
6504010	1.9	ABS		1

High Impact ABS plastic and UV protected | Covers your vehicles mudguard from pallets and loaded goods | Easy to mount on new or used vehicle
Plástico ABS alto impacto (protección UV) | Protege el guardabarros de palés y mercancías cargadas | Fácil de montar en vehículos nuevos o usados

Sprinter OPEL VIVARO 2001-2019 / NISSAN PRIMASTAR / RENAULT TRAFIC -2014 and 2015-

NEW



Ref	Kg	Mat	Article	Lot
6504011	1	ABS		1

High Impact ABS plastic and UV protected | Covers your vehicles mudguard from pallets and loaded goods | Easy to mount on new or used vehicle
Plástico ABS alto impacto (protección UV) | Protege el guardabarros de palés y mercancías cargadas | Fácil de montar en vehículos nuevos o usados

Sprinter Nissan NV400/OPEL MOVANO 2010-2021/ RENAULT MASTER 2010-

NEW



Ref	Kg	Mat	Article	Lot
6504012	2.3	ABS		1

High Impact ABS plastic and UV protected | Covers your vehicles mudguard from pallets and loaded goods | Easy to mount on new or used vehicle
Plástico ABS alto impacto (protección UV) | Protege el guardabarros de palés y mercancías cargadas | Fácil de montar en vehículos nuevos o usados

Sprinter Nissan VW CADDY 2021- L1

NEW



Ref	Kg	Mat	Article	Lot
6504013	2.4	ABS		1

High Impact ABS plastic and UV protected | Covers your vehicles mudguard from pallets and loaded goods | Easy to mount on new or used vehicle
Plástico ABS alto impacto (protección UV) | Protege el guardabarros de palés y mercancías cargadas | Fácil de montar en vehículos nuevos o usados

VW CADDY MAXI 2021- L2

NEW



Ref	Kg	Mat	Article	Lot
6504014	2.6	ABS		1

High Impact ABS plastic and UV protected | Covers your vehicles mudguard from pallets and loaded goods | Easy to mount on new or used vehicle
Plástico ABS alto impacto (protección UV) | Protege el guardabarros de palés y mercancías cargadas | Fácil de montar en vehículos nuevos o usados

VW CRAFTER 2017- / MAN TGE

NEW



Ref	Kg	Mat	Article	Lot
6504015	2.6	ABS		1

High Impact ABS plastic and UV protected | Covers your vehicles mudguard from pallets and loaded goods | Easy to mount on new or used vehicle
Plástico ABS alto impacto (protección UV) | Protege el guardabarros de palés y mercancías cargadas | Fácil de montar en vehículos nuevos o usados

VW CRAFTER 2017- / MAN TGE RWD/4WD

NEW



Ref	Kg	Mat	Article	Lot
6504016	1	ABS		1

High Impact ABS plastic and UV protected | Covers your vehicles mudguard from pallets and loaded goods | Easy to mount on new or used vehicle
Plástico ABS alto impacto (protección UV) | Protege el guardabarros de palés y mercancías cargadas | Fácil de montar en vehículos nuevos o usados



MUDGUARD COVER / KOTFLÜGELABDECKUNG / CUBIERTAS DE RUEDA

VW TRANSPORTER T5-T6 L1

NEW



Ref	Kg	Mat	Article	Lot
6504017	2.3	ABS		1

High Impact ABS plastic and UV protected | Covers your vehicles mudguard from pallets and loaded goods | Easy to mount on new or used vehicle
 Plástico ABS alto impacto (protección UV) | Protege el guardabarros de palés y mercancías cargadas | Fácil de montar en vehículos nuevos o usados

VW TRANSPORTER T5-T6 L2

NEW



Ref	Kg	Mat	Article	Lot
6504018	2.7	ABS		1

High Impact ABS plastic and UV protected | Covers your vehicles mudguard from pallets and loaded goods | Easy to mount on new or used vehicle
 Plástico ABS alto impacto (protección UV) | Protege el guardabarros de palés y mercancías cargadas | Fácil de montar en vehículos nuevos o usados

CABIN ACCESSORIES / KABINENZUBEHÖR / ACCESORIOS CABINA

DAF CF 65 / 75 / 85 Standard Roof

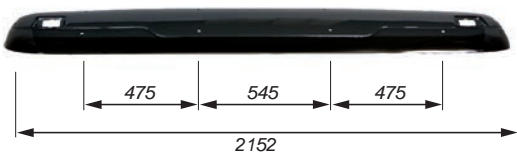

Ref	Kg	Mat	OEM	Part	Lot
6401225	4.4	PMA	1312864		1
6402225	2.7	STEEL	1434304		1

Can be used as original replacement part | Fits on all models with/without front view mirror
Se puede utilizar como pieza de repuesto original | Adaptable a todos los modelos con o sin espejo frontal

DAF LF Standard Roof

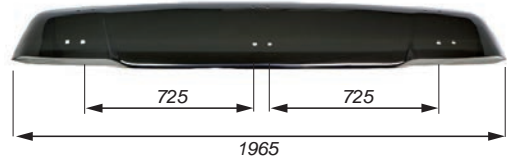

Ref	Kg	Mat	OEM	Part	Lot
6401228	4.3	PMA	1405233		1
6402227	2	STEEL	1405689		1

Can be used as original replacement part | Fits on all models without front view mirror
Se puede utilizar como pieza de repuesto original | Adaptable a todos los modelos sin espejo frontal

DAF LF 2007

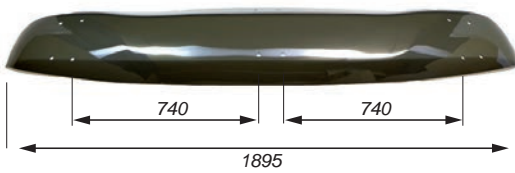

Ref	Kg	Mat	OEM	Part	Lot
6401229	4.4	PMA	1742638		1
6402233	2.8	STEEL	1794737		1

Can be used as original replacement part | Fits on all models with front view mirror
Se puede utilizar como pieza de repuesto original | Adaptable a todos los modelos con espejo frontal

DAF 95

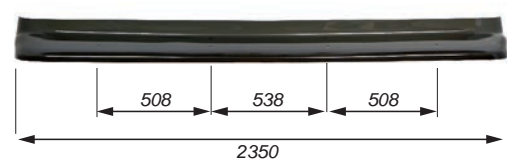

Ref	Kg	Mat	OEM	Part	Lot
6401230	4.8	PMA	66244		1
6402230	2.3	STEEL			1

Can be used as original replacement part | Fits on all models
Se puede utilizar como pieza de repuesto original | Adaptable a todos los modelos

DAF XF 95/105 Space Cab

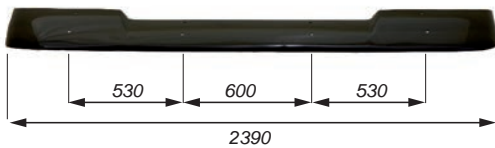

Ref	Kg	Mat	OEM	Part	Lot
6401232	4.1	PMA	1300557		1
6402232	1.7	STEEL	1311765		1

Can be used as original replacement part | Fits on all models with/without front view mirror
Se puede utilizar como pieza de repuesto original | Adaptable a todos los modelos con o sin espejo frontal

DAF XF 95/105 Comfort Cab

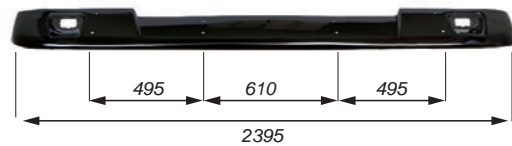

Ref	Kg	Mat	OEM	Part	Lot
6401234	3.3	PMA	1308687		1
6402234	1.9	STEEL	1311766		1

Can be used as original replacement part | Fits on all models with/without front view mirror
Se puede utilizar como pieza de repuesto original | Adaptable a todos los modelos con o sin espejo frontal

DAF XF 105 Super Space Cab

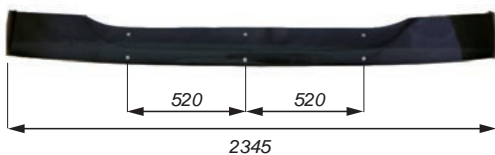

Ref	Kg	Mat	OEM	Part	Lot
6401236	3	PMA	1651597		1
6402236	1.5	STEEL			1

Can be used as original replacement part | Fits on all models with/without front view mirror
Se puede utilizar como pieza de repuesto original | Adaptable a todos los modelos con o sin espejo frontal

DAF XF 105/106 Super Space Cab + 80mm deeper

NEW

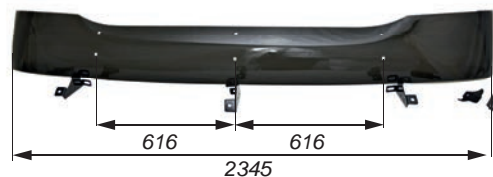

Ref	Kg	Mat	OEM	Part	Lot
6401240	4.8	PMA	1651597		1
6402240	1.9	STEEL			1

Can be used as original replacement part | 80mm deeper visor with OE-look
Se puede utilizar como pieza de repuesto original | 80 mm. más profunda que el modelo original



SUN VISORS DAF / SONNENBLENDEN DAF / VISERAS DAF

CABIN ACCESSORIES / KABINENZUBEHÖR / ACCESORIOS CABINA

DAF CF Space Cab

NEW



Ref	Kg	Mat	Part	Lot
6401227	5.3	PMA		1
6402246	2.4	STEEL		1

Can be used as original replacement part
Se puede utilizar como pieza de repuesto original

DAF XF/XG/XG+ 2022-, 80mm

NEW



Ref	Kg	Mat	Part	Lot
6401235	6.6	PMA		1
6402248	1.9	STEEL		1

Can be used as original replacement part | The kit does not include mirror drop-down leg | 80mm deeper visor with OE-look
Se puede utilizar como pieza de repuesto original | El kit no incluye pata abatible de espejo | 80 mm. más profunda con apariencia OE

DAF XF Space Cab 2017-

NEW



Ref	Kg	Mat	Part	Lot
6401237	6.7	PMA		1

Can be used as original replacement part
Se puede utilizar como pieza de repuesto original

DAF XF Super Space Cab 2017-

NEW



Ref	Kg	Mat	Part	Lot
6401238	4.2	PMA		1
6402238	1.5	PMA		1

Can be used as original replacement part
Se puede utilizar como pieza de repuesto original

DAF XG+ 2022-

NEW



Ref	Kg	Mat	Part	Lot
6401243	7.1	PMA		1
6402248	1.9	STEEL		1

Can be used as original replacement part
Se puede utilizar como pieza de repuesto original



IVECO Eurotech/Euro Trakker, Standard Roof

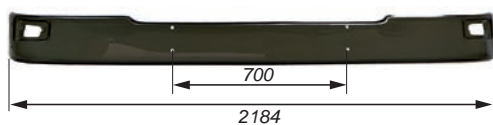

Ref	Kg	Mat	OEM	Part	Lot
6401365	6.4	PMA	2995676/93162831		1
6402415	2.15	STEEL			1

Can be used as original replacement part | Fits on all models with/without front view mirror
Se puede utilizar como pieza de repuesto original | Adaptable a todos los modelos con o sin espejo frontal

IVECO Eurotech / Trakker Cursor

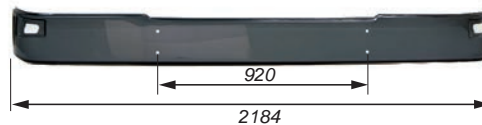

Ref	Kg	Mat	OEM	Part	Lot
6401366	7	PMA	500337805		1
6402418	1.5	STEEL			1

Can be used as original replacement part | Fits on all models with/without front view mirror
Se puede utilizar como pieza de repuesto original | Adaptable a todos los modelos con o sin espejo frontal

IVECO Eurocargo -04/2003 Standard Roof



Ref	Kg	Mat	OEM	Part	Lot
6401375	5.2	PMA	1908138		1
6402425	2.3	STEEL			1

Can be used as original replacement part | Fits on all models with/without front view mirror
Se puede utilizar como pieza de repuesto original | Adaptable a todos los modelos con o sin espejo frontal

IVECO Eurocargo 05/2003- Standard Roof

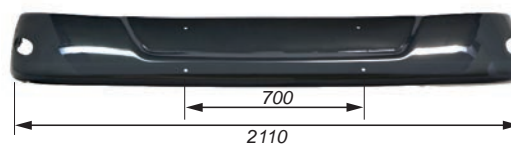

Ref	Kg	Mat	Cabin	OEM	Part	Lot
6401377	8.6	PMA		504061726		1
6402429	3.7	STEEL				1

Can be used as original replacement part | Fits on all models with/without front view mirror
Se puede utilizar como pieza de repuesto original | Adaptable a todos los modelos con o sin espejo frontal

IVECO Stralis AS

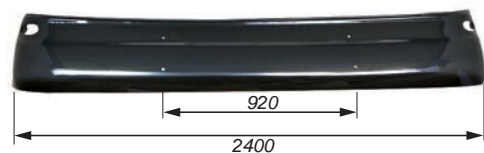

Ref	Kg	Mat	OEM	Part	Lot
6401380	4	PMA	504042824		1
6402430	2	STEEL			1

Can be used as original replacement part | Fits on all models with and without front view mirror
Pieza repuesto original | Adaptable todos modelos con/sin espejo frontal

IVECO Stralis AT/AD - 2006



Ref	Kg	Mat	OEM	Part	Lot
6401382	3.7	PMA	504089372		1
6402430	2	STEEL			1

Can be used as original replacement part | Fits on all models with/without front view mirror
Se puede utilizar como pieza de repuesto original | Adaptable a todos los modelos con o sin espejo frontal

IVECO Stralis AS 3 Cube 2007-

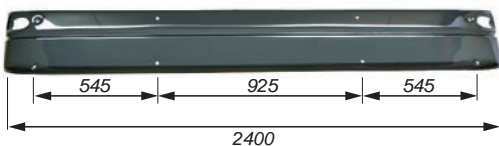

Ref	Kg	Mat	OEM	Part	Lot
6401381	3.8	PMA	504146434		1
6402432	1.4	STEEL			1

Can be used as original replacement part | Fits on all models with/without front view mirror
Se puede utilizar como pieza de repuesto original | Adaptable a todos los modelos con o sin espejo frontal

IVECO Stralis HI-ROAD/HI-STREET/TRAKKER

NEW



Ref	Kg	Mat	OEM	Part	Lot
6401384	3.7	PMA	5801715566		1
6402384	2.3	STEEL			1

Can be used as original replacement part | Fits on all models with/without front view mirror
Se puede utilizar como pieza de repuesto original | Adaptable a todos los modelos con o sin espejo frontal



SUN VISORS IVECO / SONNENBLENDEN IVECO / VISERAS IVECO

CABIN ACCESSORIES / KABINENZUBEHÖR / ACCESORIOS CABINA

IVECO Stralis S-WAY 10/2019-

NEW



Ref	Kg	Mat	Part	Lot
6401385	4.2	PMA		1
6402385	2.5	STEEL		1

Can be used as original replacement part
Se puede utilizar como pieza de repuesto original

IVECO Stralis HI-WAY

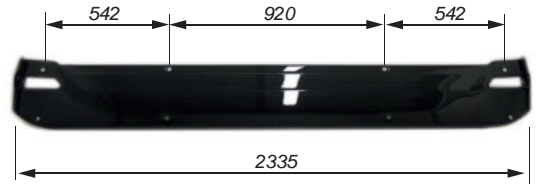

Ref	Kg	Mat	Article	OEM	Part	Lot
6401379	4.3	PMA		5801715565		1
6402416	2.3	STEEL	The bracket set doesn't include marker lights No incluye luces de posición			1

Can be used as original replacement part | Fits on all models with/without front view mirror
Se puede usar como pieza de repuesto original | Adaptable a todos los modelos con/sin espejo frontal

IVECO Stralis AD/AT/TRAKKER 2007-2013

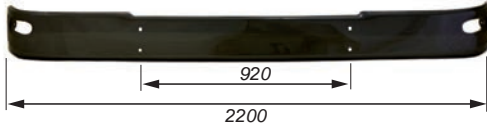

Ref	Kg	Mat	OEM	Part	Lot
6409001	3	PMA	504107220		1

Can be used as original replacement part | Fits on all models with/without front view mirror
Se puede utilizar como pieza de repuesto original | Adaptable a todos los modelos con o sin espejo frontal

IVECO Stralis S-WAY/T-WAY Narrow Cabin

NEW



Ref	Kg	Mat	Cabin	OEM	Part	Lot
6401374	4	PMA		5802454471		1
6402374	2.3	PMA				1

Can be used as original replacement part
Se puede utilizar como pieza de repuesto original



MAN L2000 Standard Roof

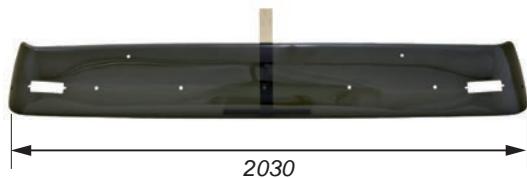

Ref	Kg	Mat	OEM	Part	Lot
6401020	3.5	PMA	85637010010		1
6402020	2.6	STEEL			1

Can be used as original replacement part | Fits on all models
Se puede utilizar como pieza de repuesto original | Adaptable a todos los modelos

MAN F90/F2000 Standard Roof

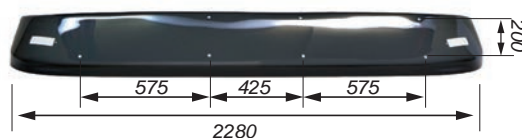

Ref	Kg	Mat	Cabin	OEM	Part	Lot
6401060	4.5	PMA		81637010011		1
6402050	2.3	STEEL				1

Can be used as original replacement part | Fits on all models
Se puede utilizar como pieza de repuesto original | Adaptable a todos los modelos

MAN M90/F90/M2000/F2000 Standard Roof

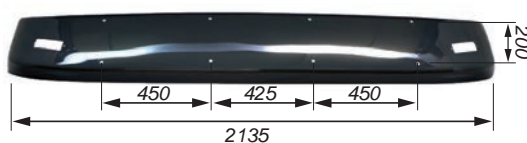

Ref	Kg	Mat	Cabin	OEM	Part	Lot
6401070	4.4	PMA		81637010010		1
6402050	2.3	STEEL				1

Can be used as original replacement part | Fits on all models | Brackets: 6402050
Se puede utilizar como pieza de repuesto original | Adaptable a todos los modelos | Kit Soportes: 6402050

MAN TGX XXL, TG-A XXL,

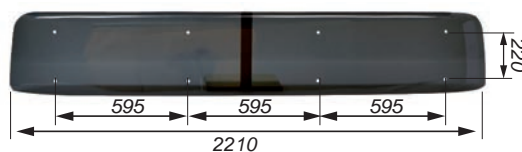

Ref	Kg	Mat	Cabin	OEM	Part	Lot
6401072	4.9	PMA		81637010044		1
6402052	2	STEEL				1

Can be used as original replacement part | Fits on all models with/without front view mirror | Ø hole smaller than the original
Se puede utilizar como pieza de repuesto original | Adaptable a todos los modelos con o sin espejo frontal | Ø agujero menor que el original

MAN TGX XL, TG-A XL 04/2004 -, Standard Roof

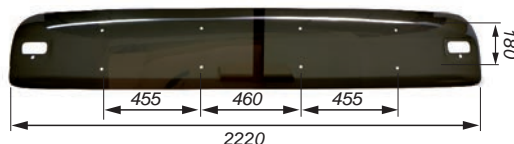

Ref	Kg	Mat	Cabin	OEM	Part	Lot
6401075	5	PMA		81.63701.0048/0062		1
6402060	2.8	STEEL				1

Can be used as original replacement part | Fits on all models with/without front view mirror | Brackets: 6402060
Se puede utilizar como pieza de repuesto original | Adaptable a todos los modelos con o sin espejo frontal | Kit Soportes: 6402060

MAN TGS LX, TG-A LX, TG-L LX, High Roof

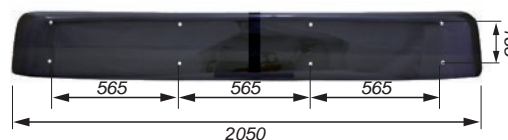

Ref	Kg	Mat	Cabin	OEM	Part	Lot
6401076	3.9	PMA		81637010045		1
6402056	1.8	STEEL				1

Can be used as original replacement part | Fits on all models with/without front view mirror | Ø hole smaller than the original
Se puede utilizar como pieza de repuesto original | Adaptable a todos los modelos con o sin espejo frontal | Ø agujero menor que el original

MAN TG-A L/M -03/2004, Standard Roof

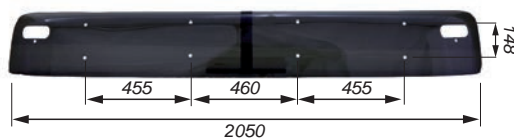

Ref	Kg	Mat	Cabin	OEM	Part	Lot
6401078	3.8	PMA		81637010030		1
6402054	2.9	STEEL				1

Can be used as original replacement part | Fits on all models with/without front view mirror
Se puede utilizar como pieza de repuesto original | Adaptable a todos los modelos con o sin espejo frontal

MAN TGS M / L, TG-L L, TG-A M / L 04/2004- St Roof

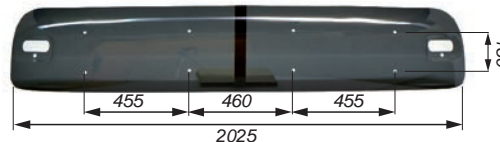

Ref	Kg	Mat	Cabin	OEM	Part	Lot
6401079	5	PMA		81.63701.0047/0060		1
6402060	2.8	STEEL				1

Can be used as original replacement part | Fits on all models with/without front view mirror
Se puede utilizar como pieza de repuesto original | Adaptable a todos los modelos con o sin espejo frontal



SUN VISORS MAN / SONNENBLENDEN MAN / VISERAS MAN

MAN TGX XLX, TG-A XLX , medium High Roof

MAN TG-L C Day Cabin

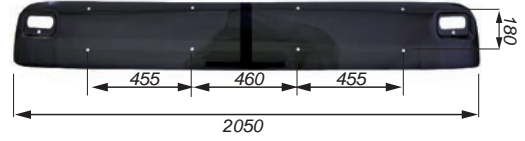
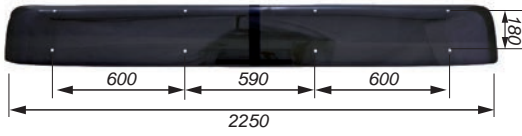

CABIN ACCESSORIES / KABINENZUBEHÖR / ACCESORIOS CABINA

Ref	Kg	Mat	Cabin	OEM	Part	Lot
6401080	3.5	PMA		81637010057		1
6402057	1.8	STEEL				1

Can be used as original replacement part | Fits on all models with/without front view mirror |
 Ø hole smaller than the original
 Se puede utilizar como pieza de repuesto original | Adaptable a todos los modelos con o
 sin espejo frontal | Ø agujero menor que el original

Ref	Kg	Mat	OEM	Part	Lot
6401082	3.8	PMA	81.63701.0055/0058		1
6402062	2.9	STEEL			1

Can be used as original replacement part | Fits on all models with/without front view mirror
 Se puede utilizar como pieza de repuesto original | Adaptable a todos los modelos con o
 sin espejo frontal



SUN VISORS MERCEDES-BENZ / SONNENBLENDEN MERCEDES-BENZ / VISERAS MERCEDES-BENZ



CABIN ACCESSORIES / KABINENZUBEHÖR / ACCESORIOS CABINA

MB Atego I/Axor I Standard Roof

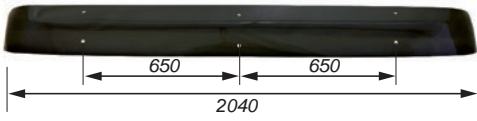

Ref	Kg	Mat	OEM	Part	Lot
6401132	3.1	PMA	9738110410		1
6402132	1.2	STEEL			1

Can be used as original replacement part | Fits on all models without front view mirror
Se puede utilizar como pieza de repuesto original | Adaptable a todos los modelos sin espejo frontal

MB MK/SK Short Cabin 381, 641

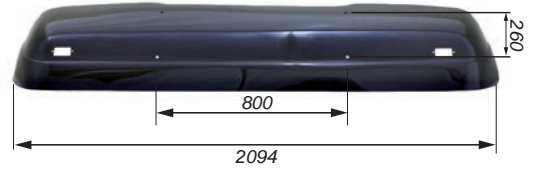

Ref	Kg	Mat	OEM	Part	Lot
6401150	6.9	PMA	3818112610		1
6402140	2.05	STEEL			1

Can be used as original replacement part
Se puede utilizar como pieza de repuesto original

MB MK/SK Medium / Medium long Cabin 383,385,642

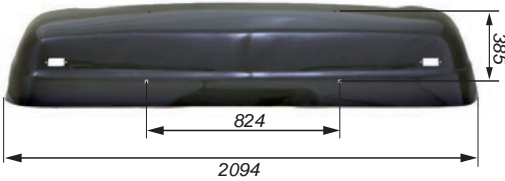

Ref	Kg	Mat	OEM	Part	Lot
6401160	7.4	PMA	3 818 112 510		1
6402150	2.5	STEEL			1

Can be used as original replacement part
Se puede utilizar como pieza de repuesto original

MB Actros MP1 / Mega Space -06/1998-

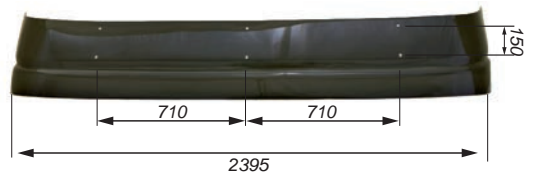

Ref	Kg	Mat	Cabin	OEM	Part	Lot
6401180	6.4	PMA		9418101010		1

Can be used as original replacement part | This model is fitted on high roof/mega space models with chassis number up to -K344165-.
Se puede utilizar como pieza de repuesto original | Este modelo sirve para todos los modelos mega space techo alto con n° chasis hasta -K344165

MB Actros MP1 / Mega Space 07/1998-

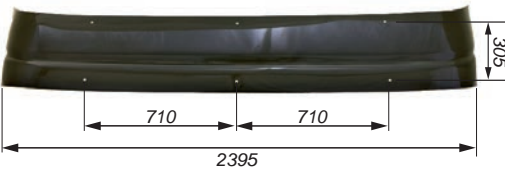

Ref	Kg	Mat	Cabin	OEM	Part	Lot
6401181	6.8	PMA		9418100010		1
6402170	3.5	STEEL				1

Can be used as original replacement part | This model is fitted on high roof/mega space models from chassis number K344165-.
Se puede utilizar como pieza de repuesto original | Este modelo sirve para todos los modelos mega space techo alto con n° chasis desde K344165-

MB Actros MP1 Standard Roof 07/1998-

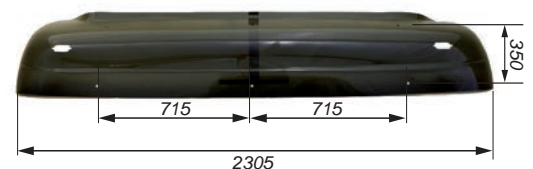

Ref	Kg	Mat	OEM	Part	Lot
6401182	8.3	PMA	9418110610		1
6402172	2.8	STEEL			1

Can be used as original replacement part | This model is fitted on high roof/mega space models with chassis number K344165-.
Se puede utilizar como pieza de repuesto original | sirve para todos modelos techo standard n° chasis -K344165

MB Actros MP2 Standard Roof

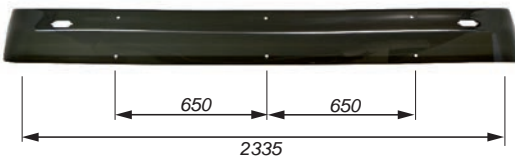

Ref	Kg	Mat	OEM	Part	Lot
6401184	3.9	PMA	9438110210		1
6402174	1.2	STEEL			1

Can be used as original replacement part | Fits on all models without front view mirror
Se puede utilizar como pieza de repuesto original | Adaptable a todos los modelos sin espejo frontal

MB Actros MP2 Eurocab /Mega Space

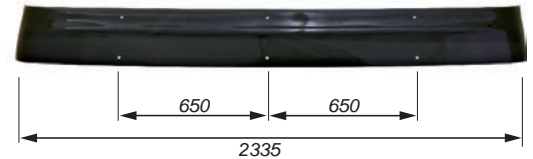

Ref	Kg	Mat	Cabin	OEM	Part	Lot
6401186	4.2	PMA		9438110010		1
6402177	1.2	STEEL				1

Can be used as original replacement part | Fits on all models without front view mirror
Se puede utilizar como pieza de repuesto original | Adaptable a todos los modelos sin espejo frontal



SUN VISORS MERCEDES-BENZ / SONNENBLENDEN MERCEDES-BENZ / VISERAS MERCEDES-BENZ

CABIN ACCESSORIES / KABINENZUBEHÖR / ACCESORIOS CABINA

MB Actros MP2 Euro cab/Mega Space (Front view)

NEW

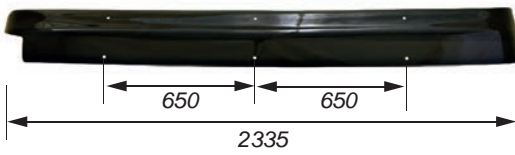

Ref	Kg	Mat	Cabin	OEM	Part	Lot
6401185	3.7	PMA		9438111010		1
6402177	1.2	STEEL				1

Can be used as original replacement part
Se puede utilizar como pieza de repuesto original

MB Actros MP3 Eurocab/Mega Space

NEW

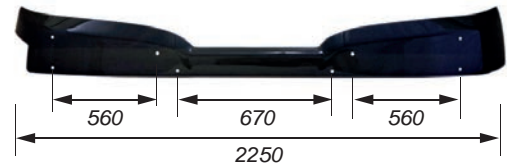

Ref	Kg	Mat	Cabin	OEM	Part	Lot
6401187	2.9	PMA		9438100410		1
6402187	2.5	STEEL				1

Can be used as original replacement part
Se puede utilizar como pieza de repuesto original

MB Actros MP3 Standard Roof

NEW

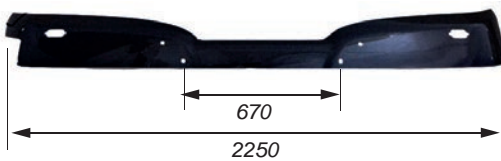

Ref	Kg	Mat	OEM	Part	Lot
6401188	2.9	PMA	9438100610		1
6402188	2	STEEL			1

Can be used as original replacement part
Se puede utilizar como pieza de repuesto original

MB Actros MP2 Standard Roof

NEW



Ref	Kg	Mat	OEM	Part	Lot
6401189	3.7	PMA	9438111210		1
6402174	1.2	STEEL			1

Can be used as original replacement part
Se puede utilizar como pieza de repuesto original

MB Actros MP4 Big Space/Giga Space

NEW



Ref	Kg	Mat	OEM	Part	Lot
6401190	3.6	PMA	9608110110		1
6402190	1.2	STEEL			1

Can be used as original replacement part
Se puede utilizar como pieza de repuesto original

MB Actros MP4 Streamspace/Arocs 2500 mm.

NEW

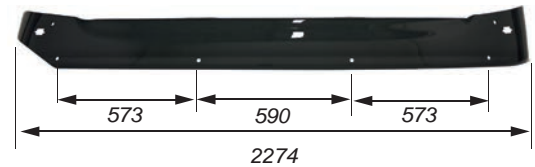

Ref	Kg	Mat	OEM	Part	Lot
6401191	3.4	PMA	9608111210/9608113010		1
6402196	2	STEEL			1

Can be used as original replacement part
Se puede utilizar como pieza de repuesto original

MB Actros MP4 Streamspace 2300 mm

NEW

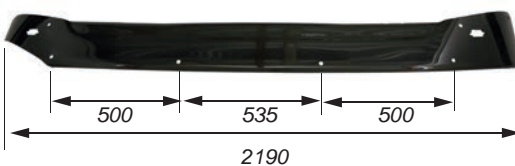

Ref	Kg	Mat	OEM	Part	Lot
6401192	3.2	PMA	9608112410		1
6402192	2	STEEL			1

Can be used as original replacement part
Se puede utilizar como pieza de repuesto original

MB Actros / Antos / Arocs MP4 Classic space 2300 mm

NEW

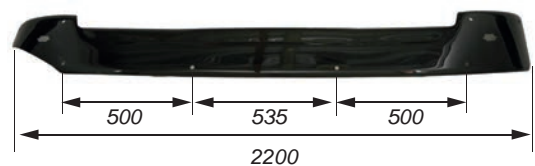

Ref	Kg	Mat	OEM	Part	Lot
6401193	3.2	PMA	9608112210		1
6402193	2	STEEL			1

Can be used as original replacement part
Se puede utilizar como pieza de repuesto original

SUN VISORS MERCEDES-BENZ / SONNENBLENDEN MERCEDES-BENZ / VISERAS MERCEDES-BENZ



MB Axor II / Atego II. Standard Roof without front view mirror

NEW

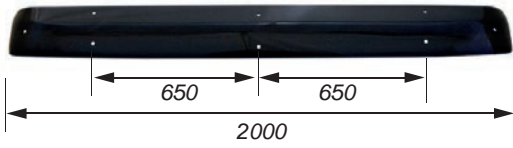

Ref	Kg	Mat	OEM	Part	Lot
6401194	3	PMA	9738110010/9738110710		1
6402194	1.2	STEEL			1

Can be used as original replacement part
Sin espejo frontal | Se puede utilizar como pieza de repuesto original

MB Axor II/Atego II Standard Roof with front view mirror

NEW

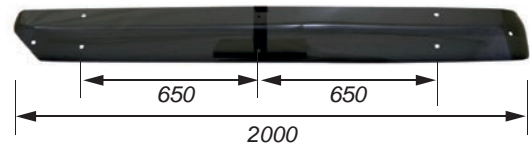

Ref	Kg	Mat	OEM	Part	Lot
6401196	2.8	PMA	9738111010/9738101010		1
6402194	1.2	STEEL			1

Can be used as original replacement part
Con espejo frontal | Se puede utilizar como pieza de repuesto original

MB LN2 Short Cabin

NEW



Ref	Kg	Mat	OEM	Part	Lot
6401199	5.8	PMA	6738110010		1
6402199	2.1	STEEL			1

Can be used as original replacement part
Se puede utilizar como pieza de repuesto original



CABIN ACCESSORIES / KABINENZUBEHÖR / ACCESORIOS CABINA



SUN VISORS RENAULT / SONNENBLENDEN RENAULT / VISERAS RENAULT

CABIN ACCESSORIES / KABINENZUBEHÖR / ACCESORIOS CABINA

RENAULT Magnum AE -2008

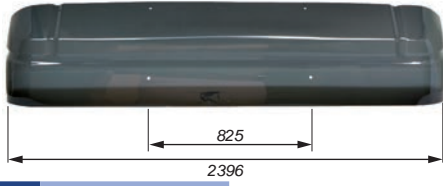

Ref	Kg	Mat	Part	Lot
6401270	10	PMA		1
6402281	3.8	STEEL		1

Fits on all models without front view mirror until -2008
Adaptable a todos los modelos hasta -2008 sin espejo frontal

RENAULT Midlum/D 2,1M, Standard Roof

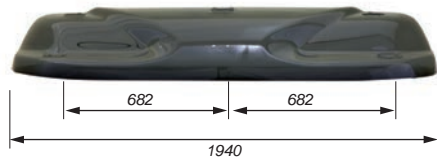

Ref	Kg	Mat	OEM	Part	Lot
6401274	7.3	PMA	20937430		1
6402273	6.3	STEEL	20819179		1

Can be used as original replacement part | Fits on all models without front view mirror
Se puede utilizar como pieza de repuesto original | Adaptable a todos los modelos sin espejo frontal

RENAULT Premium Privilege with/without front view mirror

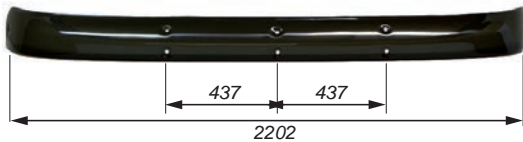

Ref	Kg	Mat	OEM	Part	Lot
6401277	3.5	PMA	50.10.578255		1
6402277	1.8	STEEL			1

Can be used as original replacement part | Fits on all models with/without front view mirror
Se puede utilizar como pieza de repuesto original | Adaptable a todos los modelos con o sin espejo frontal

RENAULT Premium, Standard Roof

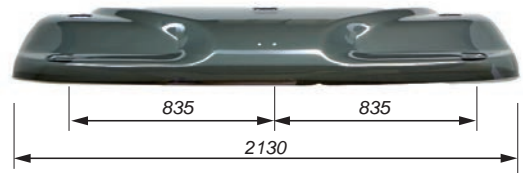

Ref	Kg	Mat	OEM	Part	Lot
6401273	14.6	PMA	20937442 / 20937446		1
6402273	6.3	STEEL	20819179		1

20397442 (without front view mirror) - 20397446 (with front view mirror) | Kit 6402273 only fits on models without front view mirror
20397442 (sin espejo frontal) - 20397446 (con espejo frontal) | El kit de soportes 6402273 solo sirve para los modelos sin espejo frontal

RENAULT Premium Privilege, High Roof

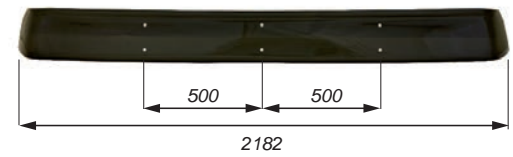

Ref	Kg	Mat	Cabin	Part	Lot
6401275	3.4	PMA			1
6402275	1.5	STEEL			1

Can be used as original replacement part | Fits on all models without front view mirror
Se puede utilizar como pieza de repuesto original | Adaptable a todos los modelos sin espejo frontal

RENAULT T-High Roof

NEW



Ref	Kg	Mat	Sup/Finish Acabado	Col	Cabin	Part	Lot
6401276	4	PMA					1
6402276	3	STEEL	Zn				1

Can be used as original replacement part
Se puede utilizar como pieza de repuesto original



SCANIA 3-serie Topline



Ref	Kg	Mat	OEM	Part	Lot
6401281	11.6	PMA	387520		1
6402286	2.6	STEEL			1

Can be used as original replacement part
Se puede utilizar como pieza de repuesto original

SCANIA R/4-serie Streamline/Highline 2 Lights

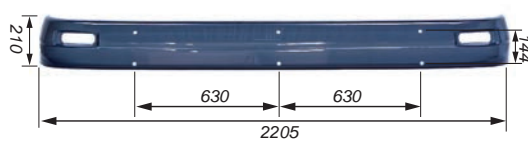

Ref	Kg	Mat	Cabin	OEM	Part	Lot
6401282	6.6	PMA		1769452-1430533		1

Can be used as original replacement part, made from one solid piece
Se puede utilizar como pieza de repuesto original, fabricado en una sola pieza

SCANIA R -06/2013 / 4-serie. Topline (4 Luces)

NEW

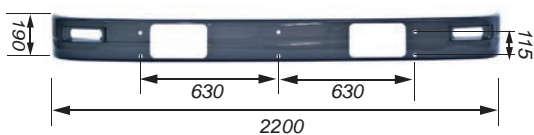

Ref	Kg	Mat	OEM	Part	Lot
6401287	3.6	PMA	1355656+1355655		1

SCANIA R -06/2013 / 4-serie. Topline (4 Lights)
Se puede utilizar como pieza de repuesto original

SCANIA R -06/2013 / 4-serie. Topline (2 Luces)

NEW

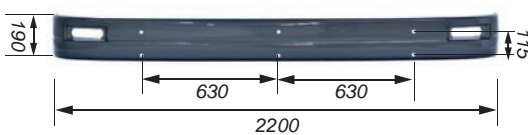

Ref	Kg	Mat	OEM	Part	Lot
6401289	3.7	PMA	1355656+1355655		1

SCANIA R -06/2013 / 4-serie. Topline (2 Lights)
Se puede utilizar como pieza de repuesto original





SUN VISORS VOLVO / SONNENBLENDEN VOLVO / VISERAS VOLVO

CABIN ACCESSORIES / KABINENZUBEHÖR / ACCESORIOS CABINA

VOLVO FL 4/6

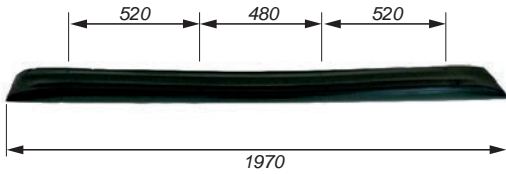

Ref	Kg	Mat	OEM	Part	Lot
6401310	7	PMA	6774105		1
6402330	1.8	STEEL			1

Can be used as original replacement part
Se puede utilizar como pieza de repuesto original

VOLVO FL 7/10/12

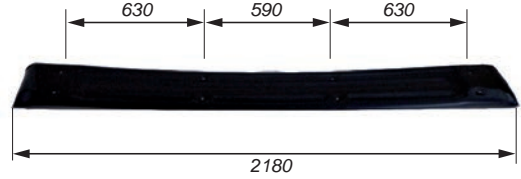

Ref	Kg	Mat	OEM	Part	Lot
6401320	9	PMA	1599652		1
6402340	2.6	STEEL			1

Can be used as original replacement part
Se puede utilizar como pieza de repuesto original

VOLVO FM 7/12, FH 12/16 Vers. 1-2001

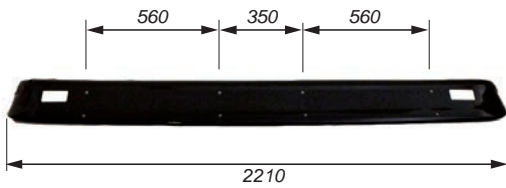

Ref	Kg	Mat	Thickn. Espesor	OEM	Part	Lot
6401327	7.2	PMA	4	8189310		1
6402346	2.3	STEEL				1

Can be used as original replacement part | The bracket set doesn't include marker lights
Se puede utilizar como pieza de repuesto original | El Kit de fijación no incluye luces de posición

VOLVO FH/FM -2001 Globetrotter

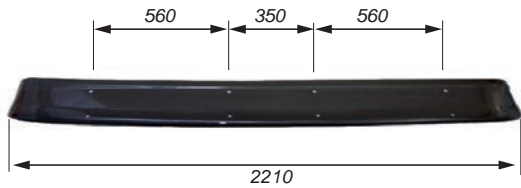

Ref	Kg	Mat	Thickn. Espesor	OEM	Part	Lot
6401328	6.6	PMA	4	8189318		1
6402347	1.9	STEEL				1

Can be used as original replacement part
Se puede utilizar como pieza de repuesto original

VOLVO FM 7/12 FH 12/16 2002-2008 VS 2 Bottom part



Ref	Kg	Mat	Thickn. Espesor	OEM	Part	Lot
6401329	3.5	PMA	4	20 456 709		1
6402344	0.01	STEEL		20530245		1

Can be used as original replacement part | Fits on all models without front view mirror
Se puede utilizar como pieza de repuesto original | Adaptable a todos los modelos sin espejo frontal

VOLVO F10/F12/F16



Ref	Kg	Mat	OEM	Part	Lot
6401330	3.8	PMA	1 584 316		1
6402335	1.6	STEEL			1

Can be used as original replacement part
Se puede utilizar como pieza de repuesto original

VOLVO FH Vers.4/5, FM5, SPECIAL MODEL 70mm deeper

NEW



Ref	Kg	Mat	Thickn. Espesor	Part	Lot
6401331	7.5	PMA	4		1

70 mm deeper than the original model | Fits on all models with or without front view mirror | Visor cannot be mounted with original light bar
70 mm más profundo que el original | Se adapta a todos los modelos con o sin espejo retrovisor | no se puede montar con la barra de luces original

VOLVO FE 2007- Standard Roof

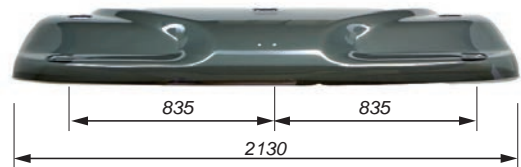

Ref	Kg	Mat	OEM	Part	Lot
6401273	14.6	PMA	20937442 / 20937446		1
6402273	6.3	STEEL	20819179		1

20937442 (without front view mirror) - 20937446 (with front view mirror) | Kit 6402273 only fits on models without front view mirror
20937442 (sin espejo frontal) - 20937446 (con espejo frontal) | El kit de soportes 6402273 solo sirve para los modelos sin espejo frontal



VOLVO FL 2007 - Standard Roof

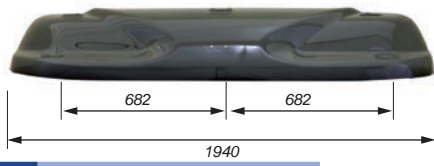

Ref	Kg	Mat	OEM	Part	Lot
6401274	7.3	PMA	20937430		1
6402273	6.3	STEEL	20819179		1

Can be used as original replacement part | Fits on all models without front view mirror
 Se puede utilizar como pieza de repuesto original | Adaptable a todos los modelos sin espejo frontal



CABIN ACCESSORIES / KABINENZUBEHÖR / ACCESORIOS CABINA



SIDE WINDOW DEFLECTORS / WINDABWEISER / DERIVABRISAS

CABIN ACCESSORIES / KABINENZUBEHÖR / ACCESORIOS CABINA

DAF XF 95 Space/Comfort Cab



Ref	Kg	Mat	Thickn. Espesor	Lot
6501115	1	PMA	3	1

Stainless Steel Staples included | Mounted with stainless steel clips to the door
Incluye kit de grapas de acero inoxidable | Montado a la puerta con el kit de grapas.

DAF XF/XF 95/105



Ref	Kg	Mat	Thickn. Espesor	Lot
6501116	1	PMA	3	1

Mounted between the window and window's rubber seal
Montado entre la ventana y la junta de goma de ventana

DAF XF106-EURO6



Ref	Kg	Mat	Thickn. Espesor	Lot
6501117	1	PMA	3	1

Mounted between the window and window's rubber seal
Montado entre la ventana y la junta de goma de ventana

DAF CF 65/75/85



Ref	Kg	Mat	Thickn. Espesor	Lot
6501118	0.68	PMA	3	1

Stainless Steel Staples included | Mounted with stainless steel clips to the door
Incluye kit de grapas de acero inoxidable. Montado a la puerta con el kit de grapas.

DAF 2022 XD/XF/XG+ SHORT

NEW



Ref	Kg	Mat	Thickn. Espesor	Lot
6501119	2	PMA	3	1

Mounted with acrylictape on windowgasket | Fits on all glasstypes (normal and isolated glass)
Cinta adhesiva doble cara en el contorno | Se adapta a todos los tipos de vidrio

DAF 2022 XD/XF/XG+

NEW



Ref	Kg	Mat	Thickn. Espesor	Lot
6501120	2	PMA	3	1

Mounted with acrylictape on windowgasket | Fits on all glasstypes (normal and isolated glass)
Cinta adhesiva doble cara en el contorno | Se adapta a todos los tipos de vidrio

DAF 2022 XD/XF/XG+ con recorte para espejo

NEW



Ref	Kg	Mat	Thickn. Espesor	Lot
6501121	2	PMA	3	1

Mounted with acrylictape on windowgasket | Fits on all glasstypes (normal and isolated glass)
Montado entre la ventana y la junta de goma | Este producto se adapta a vehiculos con cristales laterales laminados

IVECO Eurocargo/star/cursor/tech/trakker - Stralis



Ref	Kg	Mat	Thickn. Espesor	Lot
6501390	0.95	PMA	3	1

Stainless Steel Staples included | Mounted with stainless steel clips to the door
Incluye kit de grapas de acero inoxidable | Montado a la puerta con el kit de grapas

SIDE WINDOW DEFLECTORS / WINDABWEISER / DERIVABRISAS



CABIN ACCESSORIES / KABINENZUBEHÖR / ACCESORIOS CABINA

IVECO S-WAY / X-WAY 10/2019-

NEW



Ref	Kg	Mat	Thickn. Espesor	Lot
6501214	0.95	PMA	3	1

Mounted with acrylictape on windowgasket
Montado entre la ventana y la junta de goma

MAN L2000



Ref	Kg	Mat	Thickn. Espesor	Lot
6501160	0.65	PMA	3	1

Stainless Steel Staples included | Mounted with stainless steel clips to the door
Incluye kit de grapas de acero inoxidable | Montado a la puerta con el kit de grapas

MAN F2000



Ref	Kg	Mat	Thickn. Espesor	Lot
6501175	0.9	PMA	3	1

Stainless Steel Staples included | Mounted with stainless steel clips to the door
Incluye kit de grapas de acero inoxidable | Montado a la puerta con el kit de grapas

MAN TGS, TGX, TG-A, TG-M, TG-L, All Models



Ref	Kg	Mat	Thickn. Espesor	Lot
6501179	1	PMA	3	1

Stainless Steel Staples included | Mounted with stainless steel clips to the door
Incluye kit de grapas de acero inoxidable | Montado a la puerta con el kit de grapas

MAN TG1/TG2/TG3 All Models

NEW



Ref	Kg	Mat	Thickn. Espesor	Lot
6501178	2	PMA	3	1

Mounted with acrylictape on windowgasket | Fits on all glasstypes (normal and isolated glass)
Montado con cinta acrílica en la puerta | Se adapta a todos los tipos de vidrio (vidrio normal y aislado)

MERCEDES-BENZ Atego / Axor, MODELS I and II



Ref	Kg	Mat	Thickn. Espesor	Lot
6501022	1	PMA	3	1

Stainless Steel Staples included | Mounted with stainless steel clips to the door
Incluye kit de grapas de acero inoxidable | Montado a la puerta con el kit de grapas

MERCEDES-BENZ SK



Ref	Kg	Mat	Thickn. Espesor	Lot
6501050	0.68	PMA	3	1

Mounted between the window and window's rubber seal
Montado entre la ventana y la junta de goma de ventana

MERCEDES-BENZ Actros



Ref	Kg	Mat	Thickn. Espesor	Lot
6501045	1	PMA	3	1

Stainless Steel Staples included | Mounted with stainless steel clips to the door
Incluye kit de grapas de acero inoxidable | Montado a la puerta con el kit de grapas



SIDE WINDOW DEFLECTORS / WINDABWEISER / DERIVABRISAS

CABIN ACCESSORIES / KABINENZUBEHÖR / ACCESORIOS CABINA

MERCEDES-BENZ Actros MP2/MP3



Ref	Kg	Mat	Thickn. Espesor	Lot
6501046	1	PMA	3	1

Stainless Steel Staples included | Mounted with stainless steel clips to the door
Incluye kit de grapas de acero inoxidable | Montado a la puerta con el kit de grapas

MERCEDES-BENZ MP4/MP5/Antos/Arocs 2014

NEW



Ref	Kg	Mat	Thickn. Espesor	Lot
6501048	2	PMA	3	1

Mounted with acrylictape on windowgasket | Fits on all glasstypes (normal and isolated glass)
Cinta adhesiva doble cara en el contorno | Se adapta a todos los tipos de vidrio

RENAULT T.RANGE



Ref	Kg	Mat	Thickn. Espesor	Lot
6501228	1	PMA	3	1

Mounted between the window and window's rubber seal
Montado con adhesivo entre la ventana y la junta de goma de ventana

RENAULT Magnum AE



Ref	Kg	Mat	Thickn. Espesor	Lot
6501230	1	PMA	3	1

Mounted between the window and window's rubber seal
Montado entre la ventana y la junta de goma de ventana

RENAULT Magnum AE 2009-



Ref	Kg	Mat	Thickn. Espesor	Lot
6501232	1	PMA	3	1

Mounted between the window and window's rubber seal
Montado entre la ventana y la junta de goma de ventana

SCANIA R/S-serie, NEW GENERATION



Ref	Kg	Mat	Thickn. Espesor	Lot
6501079	0.95	PMA	3	1

Made of high quality cast acrylic | Mounted with acrylic on the door | Fits all types of glass (normal and insulated glass)
Hecho de acrílico fundido de alta calidad | Montado con acrílico en la puerta | Se adapta a todos los tipos de cristal (vidrio normal y aislado)

SCANIA R-Serie / STREAMLINE 2013-



Ref	Kg	Mat	Thickn. Espesor	Lot
6501077	1	PMA	3	1

Mounted between the window and window's rubber seal
Montado entre la ventana y la junta de goma de ventana

SCANIA R/4-Serie/Streamline 2013- EURO 6



Ref	Kg	Mat	Thickn. Espesor	Lot
6501078	1	PMA	3	1

Stainless Steel Staples included | Mounted with stainless steel clips to the door
Incluye kit de grapas de acero inoxidable | Montado a la puerta con el kit de grapas

SCANIA 3-Serie



Ref	Kg	Mat	Thickn. Espesor	Lot
6501080	0.9	PMA	3	1

Mounted between the window and window's rubber seal
Montado entre la ventana y la junta de goma de ventana

SCANIA R/S-serie, NEW GENERATION

NEW



Ref	Kg	Mat	Thickn. Espesor	Lot
6501081	1.7	PMA	3	1

Mounted with acrylictape on windowgasket | Fits on all glasstypes (normal and isolated glass)
Montado con cinta acrílica en la puerta | Se adapta a todos los tipos de vidrio (vidrio normal y aislado)

VOLVO FE-FL | DAF LF | RENAULT Midlum/Premium

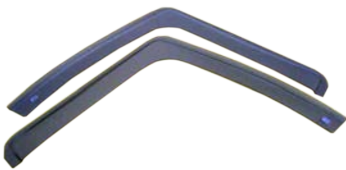

Ref	Kg	Mat	Thickn. Espesor	Lot
6501235	1.2	PMA	3	1

Stainless Steel Staples included | Mounted with stainless steel clips to the door
Incluye kit de grapas de acero inoxidable | Montado a la puerta con el kit de grapas

VOLVO FL-7/FL-10



Ref	Kg	Mat	Thickn. Espesor	Lot
6501320	0.84	PMA	3	1

Mounted between the window and window's rubber seal
Montado entre la ventana y la junta de goma de ventana

VOLVO FH4-5/FM5 EURO6



Ref	Kg	Mat	Thickn. Espesor	Lot
6501332	0.8	PMA	3	1

Mounted between the window and window's rubber gasket
Montado con adhesivo entre la ventana y la junta de goma de ventana

VOLVO FH 12/16



Ref	Kg	Mat	Thickn. Espesor	Lot
6501341	1	PMA	3	1

Stainless Steel Staples included | Mounted with stainless steel clips to the door
Incluye kit de grapas de acero inoxidable | Montado a la puerta con el kit de grapas

FORD F-MAX

NEW

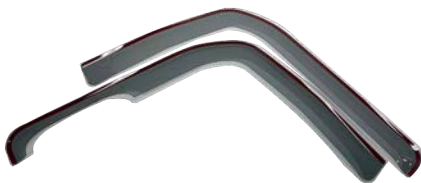

Ref	Kg	Mat	Thickn. Espesor	Lot
6501401	1.8	PMA	3	1

Mounted with acrylictape on windowgasket | Fits on all glasstypes (normal and isolated glass)
Montado con cinta acrílica en la puerta | Se adapta a todos los tipos de vidrio (vidrio normal y aislado)



DEFLECTORS / DEFLEKTOREN / DEFLECTORES

CABIN ACCESSORIES / KABINENZUBEHÖR / ACCESORIOS CABINA

Dirt Deflector VOLVO FH/ RENAULT-T/SCANIA Streamline
Schmützfänger Vorne VOLVO FH/ RENAULT-T/SCANIA Streamline
Deflector Suciedad VOLVO FH/ RENAULT-T/SCANIA Streamline

NEW



Ref	Kg	Mat	Lot
6503001	1.8	ABS	1

Prevents your vehicle's sidewindow, sidedoor and mirror from getting dusty | Easy to mount | Can be easily painted | UV-proof ABS-PMMA
Evita suciedad y polvo en ventana, puerta y espejo | Fácil de montar | Se puede pintar fácilmente | Material: ABS-PMMA resistente a rayos UV

Dirt Deflector SCANIA S/R 2017-
Schmützfänger Vorne SCANIA S/R 2017-
Deflector Suciedad SCANIA S/R 2017-

NEW



Ref	Kg	Mat	Article	Lot
6503010	2.7	ABS	L650x205Wx310H	1

Double skin UV-proof ABS-PMMA | Prevents your vehicle getting dusty/dirty | Includes mounting set | Can be easily painted
ABS-PMMA de doble capa resistente a rayos UV | Evita que el lateral del vehículo se ensucie | Set de montaje incluido | Se puede pintar fácilmente

Dirt Deflector SCANIA P/G/S/R 2017-
Schmützfänger Vorne SCANIA P/G/S/R 2017-
Deflector Suciedad SCANIA P/G/S/R 2017-

NEW



Ref	Kg	Mat	Article	Lot
6503011	1.8	ABS	L500x105Wx310H	1

Double skin UV-proof ABS-PMMA | Prevents your vehicle getting dusty/dirty | Includes mounting set | Can be easily painted
ABS-PMMA de doble capa resistente a rayos UV | Evita que el lateral del vehículo se ensucie | Set de montaje incluido | Se puede pintar fácilmente

Dirt Deflector VOLVO FH Vers 5
Schmützfänger Vorne VOLVO FH Vers 5
Deflector Suciedad VOLVO FH Vers 5

NEW



Ref	Kg	Mat	Article	Lot
6503020	1.8	ABS	L500x105Wx310H	1

Double skin UV-proof ABS-PMMA | Prevents your vehicle getting dusty/dirty | Includes mounting set | Can be easily painted
ABS-PMMA de doble capa resistente a rayos UV | Evita que el lateral del vehículo se ensucie | Set de montaje incluido | Se puede pintar fácilmente

Dirt Deflector DAF 2022- XF/XG/XG+
Schmützfänger Vorne DAF 2022- XF/XG/XG+
Deflector Suciedad DAF 2022- XF/XG/XG+

NEW



Ref	Kg	Mat	Article	Lot
6503030	2.8	ABS	L650x205Wx310H	1

Double skin UV-proof ABS-PMMA | Prevents your vehicle getting dusty/dirty | Includes mounting set | Can be easily painted
ABS-PMMA de doble capa resistente a rayos UV | Evita que el lateral del vehículo se ensucie | Set de montaje incluido | Se puede pintar fácilmente

Dirt Deflector IVECO S-WAY / X-WAY 10/2019-
Schmützfänger Vorne IVECO S-WAY / X-WAY 10/2019-
Deflector Suciedad IVECO S-WAY / X-WAY 10/2019-

NEW



Ref	Kg	Mat	Article	Lot
6503040	3	ABS	L650x205Wx310H	1

Double skin UV-proof ABS-PMMA | Prevents your vehicle getting dusty/dirty | Includes mounting set | Can be easily painted
ABS-PMMA de doble capa resistente a rayos UV | Evita que el lateral del vehículo se ensucie | Set de montaje incluido | Se puede pintar fácilmente

VOLVO Advertising Plate for Frontgrill
Platte für Frontgrill VOLVO
Placa Frontgrill VOLVO

Ref	Kg	Col	Article	Lot
6504501	1.2	○	VOLVO FH Vers 4 L1075x225Wx8H	1
6504502	1.5	○	VOLVO FH Vers 5 L1900x265Wx8H	1
6504503	1.2	○	VOLVO FM/FMX Vers 4 L1610x255Wx11H	1
6504504	1	○	VOLVO FM/FMX Vers 5 L1570x225Wx8H	1
6504505	1.8	○	VOLVO FE 2014- L1570x225Wx8H	1
6504506	1.8	○	VOLVO FL 2014- L1800x225Wx8H	1

Includes mounting tape | Color: VOLVO WINTER WHITE | The plate can be easily painted to other colour
Incluye cinta de montaje | Color: VOLVO WINTER WHITE | Puede ser pintada en otro color





Headlight Eyelid SCANIA R-SERIE NEXT GENERATION
Scheinwerfer Augenlid SCANIA R-SERIE NEXT GENERATION
Párpado de Faro SCANIA R-SERIE NEXT GENERATION

NEW

Ref	Kg	Mat	Col	Article	Lot
6502041	0.1	ABS	○	L480x90Wx100H	1

Without lowering the luminous efficacy | mounting with tape | Can be easily painted in vehicle color
| Made from UV-proof ABS-PMMA | RAL9010
ABS-PMMA resistente a rayos UV | RAL9010 | Personaliza la apariencia sin perder eficiencia luminica |
Montaje adhesivo | Se puede pintar fácilmente



Headlight Eyelid SCANIA R-SERIE NEXT GENERATION Vers.2
Scheinwerfer Augenlid SCANIA R-SERIE NEXT GENERATION Vers.2
Párpado de Faro SCANIA R-SERIE NEXT GENERATION Vers.2

NEW

Ref	Kg	Mat	Col	Article	Lot
6502042	0.1	ABS	○	L480x90Wx100H	1

Without lowering the luminous efficacy | mounting with tape | Can be easily painted in vehicle color
| Made from UV-proof ABS-PMMA | RAL9010
ABS-PMMA resistente a rayos UV | RAL9010 | Personaliza la apariencia sin perder eficiencia luminica |
Montaje adhesivo | Se puede pintar fácilmente



Headlight Eyelid DAF 2022- XD/XF/XG/XG+
Scheinwerfer Augenlid DAF 2022- XD/XF/XG/XG+
Párpado de Faro DAF 2022- XD/XF/XG/XG+

NEW

Ref	Kg	Mat	Col	Article	Lot
6502040	0.1	ABS	○	L480x90Wx100H	1

Without lowering the luminous efficacy | mounting with tape | Can be easily painted in vehicle color |
Made from UV-proof ABS-PMMA | RAL9010
Sin pérdida de eficacia luminosa | Montado con cinta | Se puede pintar fácilmente en el color del vehículo |
Material: ABS-PMMA resistente a rayos UV



SCANIA 2017- S/R NEXT GENERATION Windshield Guard
Windschutzscheibenschutz SCANIA 2017- S/R NEXT GENERATION
Protector Parabrisas SCANIA 2017- S/R NEXT GENERATION

NEW

Ref	Kg	Mat	Col	Article	Lot
6504520	6	ABS	○	L2450x335Wx300H	1

high quality ABS/PMMA Plastic | Includes mounting set | Color: Piano Black |
Can be easily painted to other colour
Plástico ABS/PMMA alta calidad | Incluye material de montaje | Color: piano black |
Puede ser pintada en otro color





DEFLECTORS / DEFLEKTOREN / DEFLECTORES

CABIN ACCESSORIES / KABINENZUBEHÖR / ACCESORIOS CABINA

Spoiler 2 Kit Top Corner Part Volvo FH-4 Globetrotter XL
Windabweiser 2er-Kit Volvo FH-4 Globetrotter XL
Kit 2 Spoilers VOLVO FH-4 Globetrotter XL

Ref	Kg	Mat	Pos	Lot
6502030	1	ABS		1



Spoiler 2 Kit Top Corner Part Volvo FH-4
Windabweiser 2er Volvo FH-4 Globetrotter XL
Kit 2 Spoilers VOLVO FH-4

Ref	Kg	Mat	Pos	Lot
6502032	1	ABS		1



WHEEL CAPS AND ACCESORIES / RADKAPPEN UND ZUBEHÖR / TAPACUBOS Y ACCESORIOS



CABIN ACCESSORIES / KABINENZUBEHÖR / ACCESORIOS CABINA

Front Wheel Hub Cap Stainless Steel 19.5"
Radzierdeckel Vorn 19.5"
Tapacubos Delantero Inox 19.5"

Ref	Kg	Mat	Sup/Finish Acabado	Pos	Lot
6201040	0.82	INOX			2

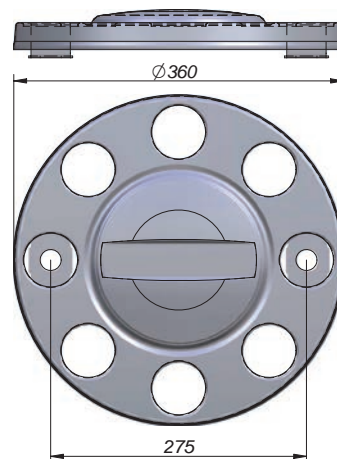

Front Wheel Hub Cap Stainless Steel 22.5"
Radzierdeckel Vorn 22.5"
Tapacubos Delantero Inox 22.5"

Ref	Kg	Mat	Sup/Finish Acabado	Pos	Lot
6201050	1.28	INOX			2

DISCO TIR4 | support Ø 24

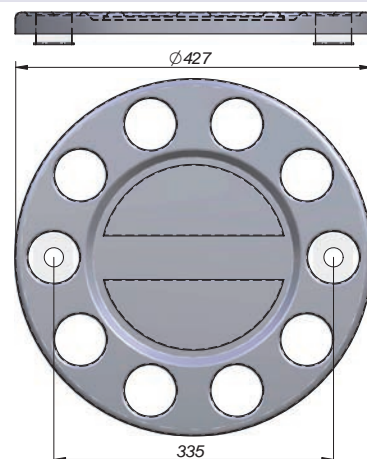
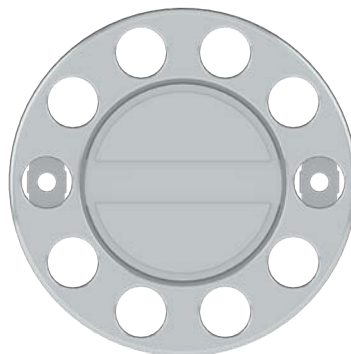

Ring Wheel Hub Cap Stainless Steel 22.5"
Radzierring 22.5"
Aro Tapacubos Inox 22,5"

Ref	Kg	Mat	Sup/Finish Acabado	Pos	Lot
6201070	0.79	INOX			2

DISCO TIR4 | support Ø 24

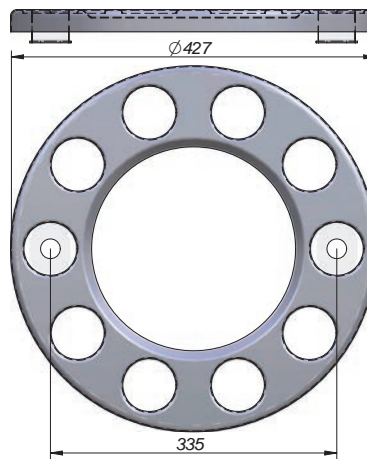

Front Wheel Hub Cap 17.5" Stainless Steel
Radzierdeckel Vorn 17.5"
Tapacubos Delantero Inox 17.5"

Ref	Kg	Mat	Sup/Finish Acabado	Pos	Lot
6201110	1	INOX			2

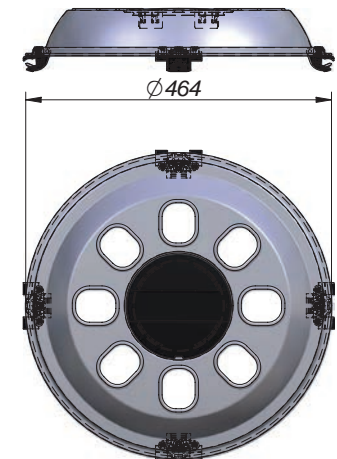



WHEEL CAPS AND ACCESORIES / RADKAPPEN UND ZUBEHÖR / TAPACUBOS Y ACCESORIOS

CABIN ACCESSORIES / KABINENZUBEHÖR / ACCESORIOS CABINA

Rear Wheel Hub Cap 17.5" Stainless Steel
Radzierdeckel Hinterrad 17.5"
Tapacubos Trasero Inox 17.5"

Ref	Kg	Mat	Sup/Finish Acabado	Pos	Lot
6201120	0.89	INOX			2

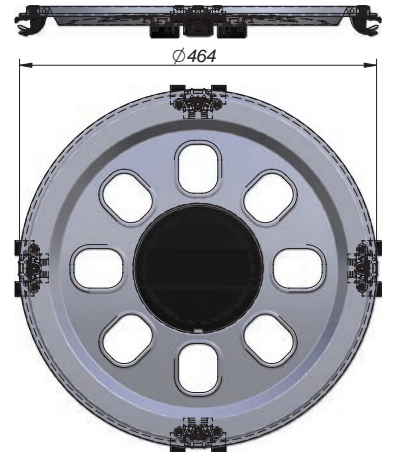

Front Wheel Hub Cap 19.5" Stainless Steel
Radzierdeckel Vorn 19.5"
Tapacubos Delantero Inox 19.5"

Ref	Kg	Mat	Sup/Finish Acabado	Pos	Lot
6201130	1.16	INOX			2

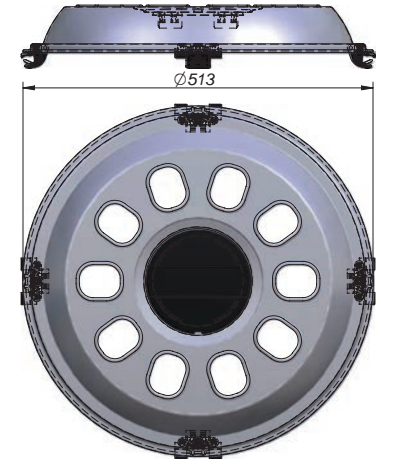

Rear Wheel Hub Cap 19.5" Stainless Steel
Radzierdeckel Hinterrad 19.5"
Tapacubos Trasero Inox 19.5"

Ref	Kg	Mat	Sup/Finish Acabado	Pos	Lot
6201140	1.17	INOX			2

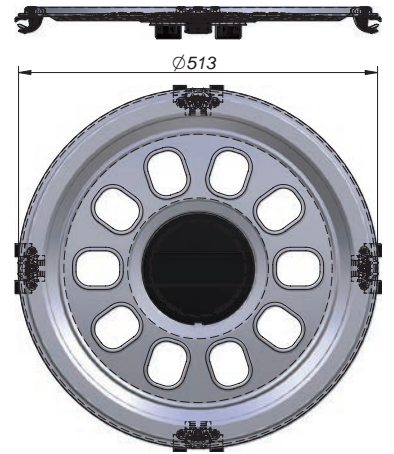

Front Wheel Hub Cap 22.5" Stainless Steel
Radzierdeckel Vorn 22.5"
Tapacubos Delantero Inox 22.5"

Ref	Kg	Mat	Sup/Finish Acabado	Pos	Lot
6201150	1.47	INOX			2

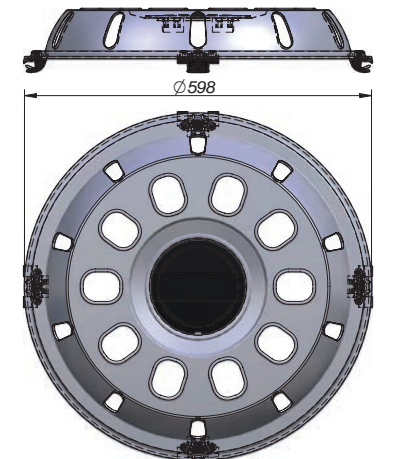

Rear Wheel Hub Cap 22.5" Stainless Steel
Radzierdeckel Hinterrad 22.5" Inox
Tapacubos Trasero Inox 22.5"

Ref	Kg	Mat	Sup/Finish Acabado	Pos	Lot
6201160	1.56	INOX			2



Fixing Clamp
Befestigungsklammer
Grapa Lateral

Ref	Kg	Mat	Lot
6201410	0.04		20

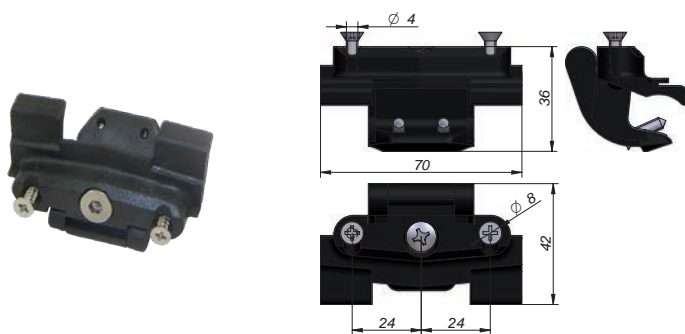

Central Plastic Cap for Wheel Cover
Mitten-Kunststoffkappe für Radzierdeckel
Tapa Central Tapacubos Universal

Ref	Kg	Mat	Lot
6201420	0.09	ABS	2

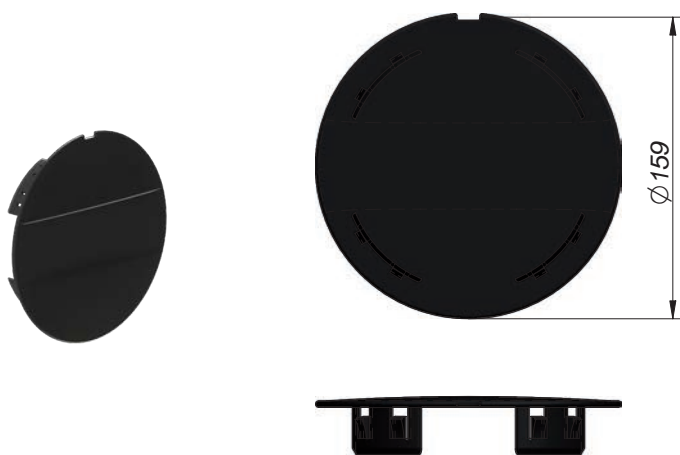

CABIN ACCESSORIES / KABINENZUBEHÖR / ACCESORIOS CABINA



WHEEL CAPS AND ACCESORIES / RADKAPPEN UND ZUBEHÖR / TAPACUBOS Y ACCESORIOS

CABIN ACCESSORIES / KABINENZUBEHÖR / ACCESORIOS CABINA

Pack 20 units Wheel Screw Cap Ø51
Pack 20 units Radschraubenkappe 32 Ø51
Pack 20 Uds Tapón Tornillo Rueda Ø51

Ref	Kg	Mat	Sup/Finish Acabado	A	B	Ø	Lot	Pack
6251510	0.28	ABS	Cr	32	39	51	1	20
6251530	0.32	ABS	Cr	33	50	51	1	20

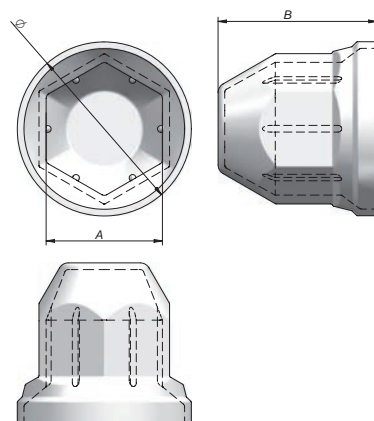

Pack 20 units Wheel Screw Cap Ø51
Pack 20 units Radschraubenkappe Ø51
Pack 20 uds. Tapón Tornillo Rueda Ø51

Ref	Kg	Mat	Sup/Finish Acabado	A	Ø	Lot	Pack
6251512	0.4	ABS	Cr	32	51	1	20

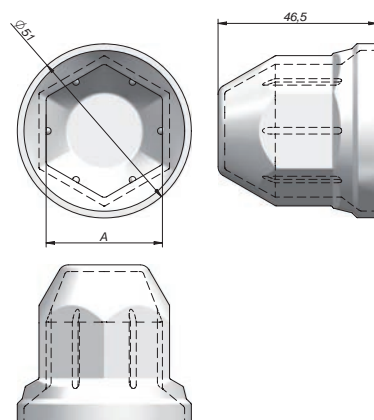

Pack 20 units Wheel Screw Cap
Pack 20 units Radschraubenkappe
Pack 20 uds. Tapón tornillo Rueda

Ref	Kg	Mat	Sup/Finish Acabado	A	Ø	Lot	Pack
6251532	0.3	ABS	Cr	32-33	59	1	20
6251538	0.4	ABS	Cr	33	57	1	20

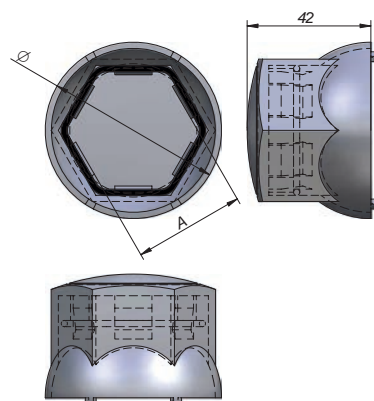

Pack 20 units Wheel Screw Cap H40
Pack 20 units Radschraubenkappe H40
Pack 20 Uds Tapón Tornillo Rueda H40

Ref	Kg	Mat	Sup/Finish Acabado	A	Ø	Lot	Pack
6251535	0.46	ABS	Cr	32-33	57	1	20

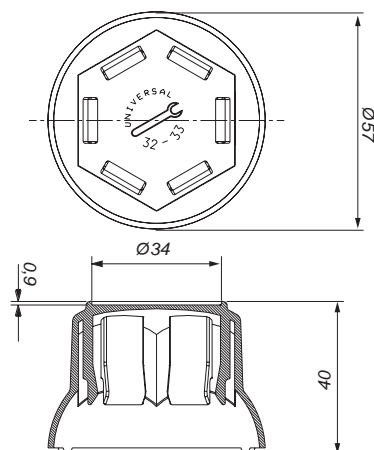

WHEEL CAPS AND ACCESORIES / RADKAPPEN UND ZUBEHÖR / TAPACUBOS Y ACCESORIOS



CABIN ACCESSORIES / KABINENZUBEHÖR / ACCESORIOS CABINA

Pack 20 units Wheel Screw Cap H42
Pack 20 units Radschraubenkappe H42
Pack 20 Uds Tapón Tornillo Rueda H42

Ref	Kg	Mat	Sup/Finish Acabado	A	Ø	Lot	Pack
6251536	0.4	ABS	Cr	33	57	1	20

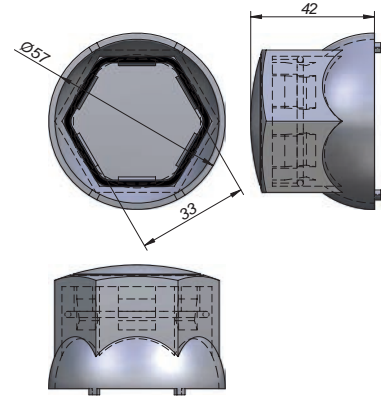

Pack 20 units Wheel Screw Cap 32 H33,5 Ø60
Pack 20 units Radschraubenkappe 32 H33,5 Ø60
Pack 20 Uds Tapón Tornillo Rueda Ø60 (Caja)

Ref	Kg	Mat	Sup/Finish Acabado	A	Lot	Pack
6251520	0.34	ABS	Cr	32	1	20

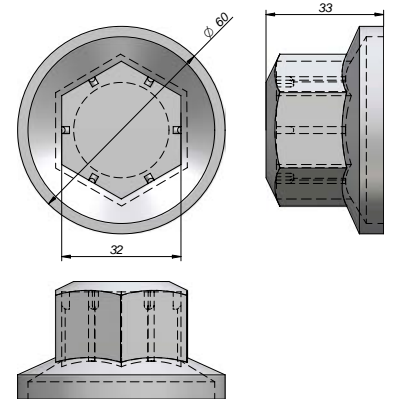

Checkpoint - Visual nut indicator (Bag 10 units)
Checkpoint - Sichtnussanzeige (Beutel 10 Einheiten)
Checkpoint - Indicador visual de tuerca (Bolsa 10 unidades)

Ref	Kg	Mat	Col	A	Lot	Pack
6201546	0.05		Black	32	1	10
6201548	0.05		Yellow	32	1	10



Visual indicator of loose nut and overheating | Advantages: Cost savings and inspection times | Other optional measures
Indicador visual de tuerca aflojada y de sobrecalentamiento | Ventajas: Ahorro de costos y de tiempos de inspección |
Otras medidas opcionales

Si se colocan correctamente, los puntos de control solo pueden estar fuera de alineación hasta 3.75°, ya que si (en el punto de ajuste) la tuerca está alineada más allá de los 3.75°, el punto de control se puede girar y colocar en el siguiente conjunto de dientes.

If fitted correctly, Checkpoints can be only up to 3.75° out of alignment, since if (at the point of fitment) the nut is aligned past 3.75° the Checkpoint can be rotated and fitted on the next tooth-set.

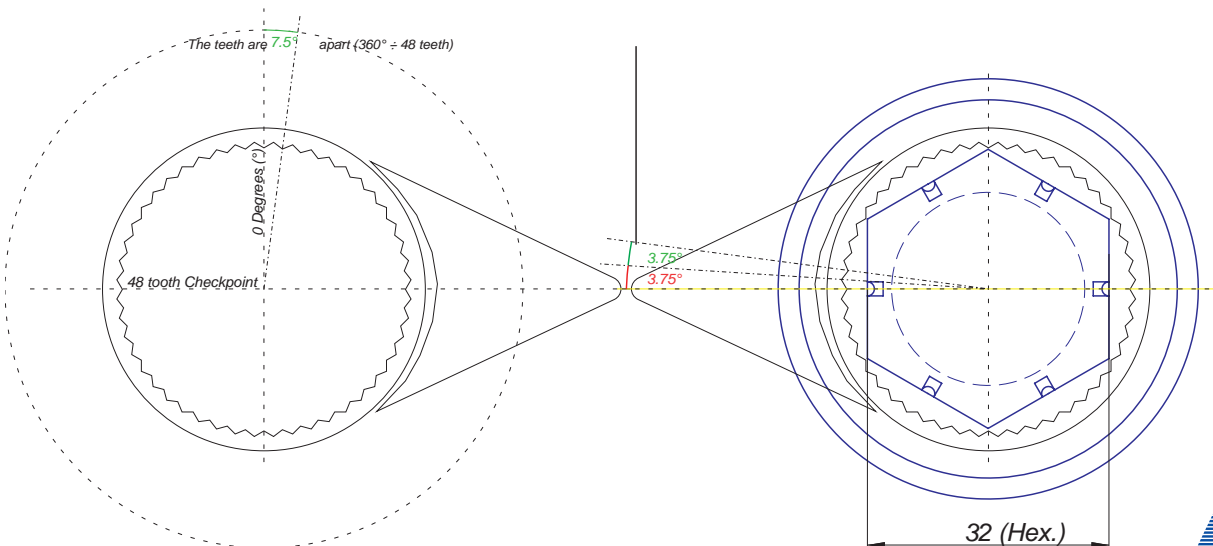



HORNS AND ACCESORIES / FANFAREN UND ZUBEHÖR / BOCINAS Y ACCESORIOS

CABIN ACCESSORIES / KABINENZUBEHÖR / ACCESORIOS CABINA

Round Air Horn
Runde Fanfare
Bocina Redonda

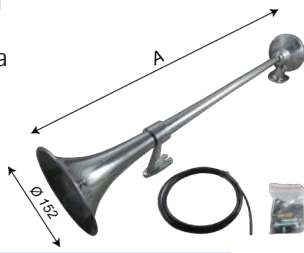

Ref	Kg	Mat	Sup/Finish Acabado	A	Lot
6301330	2.6	STEEL	Cr	650	1
6301335	3.16	Cu-Zn	Cr	750	1
6301340	3.4	Cu-Zn	Cr	970	1

Operating Psi : 45-115M or E | Db Rating : 120

Air Horn Set
2-Horn Fanfare
Juego de Bocinas

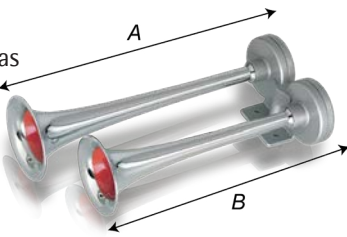

Ref	Kg	Mat	Sup/Finish Acabado	A	B	Lot
6301020	1.15	Cu-Zn	Cr	345	297	1

Work Pressure: 4-8,5 bar | 117 db (A) | A:395 Hz +/-5% - B:360 Hz +/-5% | Válves: 6301110-6301120-6301130 (no included)

Presión de Ejercicio: 4-8,5 bar | 117 db (A) | Frecuencia: A:395 Hz +/-5% - B:360 Hz +/-5% | Válvulas: 6301110-6301120-6301130 (suministro a parte)
Homologacion: CEE-ECE-ONU

Push Air Horn Valve
Fanfarenventil Drucknopf
Válvula de Bocina para pisar



Ref	Kg	Lot
6301120	0.21	1

Push valve
Válvula a pedral

Pull Air Horn Valve
Fanfaren-Zugventil
Válvula de Bocina tirador



Ref	Kg	Lot
6301110	0.21	1

Pull valve
Válvula manual

Air Horn GIGANT
Fanfare GIGANT
Bocina GIGANT

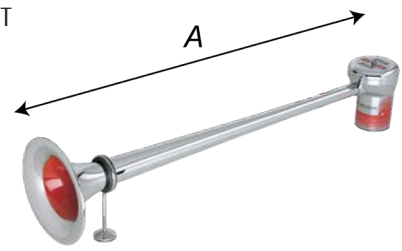

Ref	Kg	Mat	Sup/Finish Acabado	A	Article	Lot
6301050	1.67	Cu-Zn	Cr	650	Tone: high Frequency:197 Hz +/-5% Tono: agudo Frecuencia:197 Hz +/-5%	1
6301060	1.7	Cu-Zn	Cr	700	Tone: bass Frequency:182 Hz +/-5% Tono: grave Frecuencia:182 Hz +/-5%	1

Work Pressure: 4-8,5 bar | 118/118 db (A) | Válves: 6301110-6301120-6301130 (no included)
Presión de Ejercicio: 4-8,5 bar | 118/118 db (A) | Válvulas: 6301110-6301120-6301130 (suministro a parte)

Homologacion: CEE-ECE-ONU

Electrovalve
Fanfaren-Elektroventil
Electroválvula



Ref	Kg	V	Lot
6301130	0.17	24v	1

Electrovalve
Electroválvula | ØExterno = 6 mm. | ØInterno = 4 mm. | ØExt = 6 mm. | ØInt = 4 mm.

Truck and bus wiper blade 550/20"
LKW- und Buswischerblatt 550/20"
Escobilla 550/20"



Ref	Kg
79040951	0.146

Made of SPCC steel - Natural and synthec rubber with graphite coating
Fabricado en Acero SPCC - Goma natural y sintética con revestimiento de grafito

Truck and bus wiper blade 550/22"
LKW- und Buswischerblatt 550/22"
Escobilla 550/22"



Ref	Kg	Vehic	Lot
79040956	0.146		1

Made of SPCC steel - Natural and synthec rubber with graphite coating
Fabricado en Acero SPCC - Goma natural y sintética con revestimiento de grafito

Truck and bus wiper blade 600/24"
LKW- und Buswischerblatt 600/24"
Escobilla 600/22"



Ref	Kg	Vehic	Lot
79040961	0.168		1

Made of SPCC steel - Natural and synthec rubber with graphite coating
Fabricado en Acero SPCC - Goma natural y sintética con revestimiento de grafito

Truck and bus wiper blade 650/26"
LKW- und Buswischerblatt 650/26"
Escobilla 650/26"



Ref	Kg	Vehic	Lot
79040967	0.194		1

Made of SPCC steel - Natural and synthec rubber with graphite coating
Fabricado en Acero SPCC - Goma natural y sintética con revestimiento de grafito

Truck and bus wiper blade 700/28"
LKW- und Buswischerblatt 700/28"
Escobilla 700/28"



Ref	Kg	Vehic	Lot
79040971	0.22		1

Made of SPCC steel - Natural and synthec rubber with graphite coating
Fabricado en Acero SPCC - Goma natural y sintética con revestimiento de grafito

Steering wheel cover, Black leatherette
Lenkradhülle schwarzes Kunstleder
Funda para volante Polipel Negra



Ref	Kg	Mat	Col	Ø	Vehic	Lot
79323303	0.48	TPE PU	●	44-46cm.		1
79323304	0.48	TPE PU	●	46-48cm.		1

Steering wheel cover Wood-Black Leatherette Negro-Madera
Lenkradhülle holzschwarzes Kunstleder
Funda para volante



Ref	Kg	Mat	Col	Ø	Lot
7001414	0.48	TPE PU		44-46cm.	1
7001416	0.48	TPE PU		46-48cm.	1

Steering wheel cover 35-40 cm.
Lenkradhülle 35-40 cm.
Funda para volante silicona 35-40 cm. 35-40 cm.

NEW



Ref	Kg	Mat	Col	Ø	Lot
79323342	0.11	SILICON	●	35-40cm.	1

OTHER ACCESORIES / SONSTIGES ZUBEHÖR / ACCESORIOS VARIOS

CABIN ACCESSORIES / KABINENZUBEHÖR / ACCESORIOS CABINA

Blow gun
Luftsprühpistole
Pistola de aire con serpentín



Ref	Kg	Lot
6705052	0.45	1

Máx Pres: 13 Kg./cm² - With 5m coil
Máx Pres: 13 Kg./cm² - C/Serpentin 5 m. | Boquilla 3.3 mm. | Certificado CE

Battery clamp for truck body
Ladezangen für LKW Starthilfekabeln
Pinzas para batería para camión para camião



Ref	Kg	Mat	Col	A	B	Article	Lot
70177894	0.572			160mm.	100mm.	- (Negative)	1
70177893	0.572			160mm.	100mm.	+ (Positive)	1

160/100mm, Cooper/PVC

Wash brush with telescopic rod 98-168 / 25 cm.
Waschbürste mit Teleskopstange 98-168 / 25 cm.
Cepillo lavado con barra extensible



Ref	Kg	A	B	Ø	Lot
71729901	0.788	98-168cm.	25cm.	15-22	1

Telescopic handle
Barra de aluminio extensible

Reversible Car mat set
Doppelseitiges Fussmatten Set
Juego Alfombras Reversibles

NEW



Ref	Kg	Col	Lot	Pack
70310005	3.09		1	4

Reversible | D:67x45cm. | T:33x45cm.
Reversible | D:67x45cm. | T:33x45cm.

Truck booster cables (5m.)
LKW - Starthilfekabeln (5m.)
Cables de arranque camión (5m.)



Ref	Kg	Mat	Col	A	Ø	V	Article	Lot
6704054	5			700A	Ø16	12/24v	5m. X 70mm ²	1

Materials: Copper Coated Aluminum (CCA) | 700A | Insulation Thickness: 3mm.
Material: Aluminio revestido de Cobre (CCA) | 700A | Grosor de Aislante: 3mm.

Air compressor 150 PSI, 30 L/min
Luftkompressor 150 PSI, 30 L/min
Compresor de aire 150 PSI, 30 L/min



Ref	Kg	Ø	V	Lot
70623217	1.938	Ø30	12v	1

150 PSI/10,34 Bar, 30 L/min - 3m cable
150 PSI/10,34 Bar, 30 L/min - Cable 3 m.
EN 61000-6-3:2007+A1:2011; EN 55014-1:2006+A1:2009+A2:2011; EN 55014-2:1997+A1:2001+A2:2008; EN 61000-6-1:2007 (2014/30/EU)

Carpet Cover 310x220 PA-FV
Fussmatten Deckel 310x220 PA-FV
Tapa Alfombra 310x220 PA-FV



Ref	Kg	Mat	Col	Lot
6802200	0.45			1

Reinforced Polyamide (PA-FV)
Poliamida Reforzada (PA-FV)

Steering Wheel Adaptable Handle
Lenkrad-Hilfe
Bola Brida Volante



Ref	Kg	Lot
7001400	0.2	1

Universal Steering wheel knob
Lenkrad-Kugel Universal
Bola para Volante Universal



Ref	Kg	Col	Vehic	Lot
72512701	0.2			1

Standard reverse gear knob
Schaltknauf für Schalter ohne Rueckwaertsgangarretierung
Pomo Palanca Estándar

NEW



Ref	Kg	Col	Lot
72512795	0.125		1

Includes 4 adhesive patterns - For standard reverse lift-up
Incluye 4 patrones adhesivos - Para pomo estándar con gatillo

Universal gear knob
Schaltknauf universal
Pomo Palanca Universal

NEW



Ref	Kg	Lot
72512797	0.125	1

Includes 4 adhesive patterns - Universal
Incluye 4 patrones adhesivos - Para pomo estándar

Metal Fans
Metall Ventilator
Ventilador Metálico

NEW



Ref	Kg	V	Article	Lot
70570010	0.644	12v		1
70570011	0.648	24v		1
70570012	1	12v		1
70570013	1	24v		1

60 Bar - Screw fixing or clamp fixing
60 Bar - Fijación con pinza o con tornillos

Adapter 13 to 7 pole
Adapter 13 - 7 P.
Adaptador Toma Remolque 13 a 7 polos

NEW



Ref	Kg	V	Lot	Pack
70429518	0.108	12/24v	1	10

13->7 Pol. | CE
EN 61000-6-3:2007+A1:2011; EN 61000-6-1:2019 (2014/30/EU)

Adapter 7 to 13 pole
Adapter 7 - 13 P.
Adaptador Toma Remolque 7 a 13 polos

NEW



Ref	Kg	V	Lot
70429520	0.0974	12/24v	1

13->7 Pol. | CE
EN 61000-6-3:2007+A1:2011; EN 61000-6-1:2019 (2014/30/EU)

Bonnet fasteners
Haubenhalter
Gomas Sujeta Capot Motor

NEW



Ref	Kg	A	Lot
70537835	0.218	12cm.	1

CE

Plastic jerry cans
Kraftstoff-Kanister Kunststoff
Bidones Combustible de Plástico

NEW



Ref	Kg	Mat	Col	Cap.L	Article	Lot
70110021	0.758			10	29x29x19 cm.	1

For all kind of fuel
Para todo tipo de combustible
UN 3295



OTHER ACCESORIES / SONSTIGES ZUBEHÖR / ACCESORIOS VARIOS

CABIN ACCESSORIES / KABINENZUBEHÖR / ACCESORIOS CABINA

Bulb sets
Lampensätze
Estuches surtido de lámparas

NEW



Ref	Kg	V	Emark	Article	Lot
79780217	0.1	24v	E ₄	H7,P21/5W,PY21W,R5W,W5W,4 Fus.	1
79780207	0.1	24v	E ₄	H1,P21/5W,PY21W,R5W,W5W,4 Fus.	1

Reg.UNE ECE R 37

P21W Bulbs
P21W Glühbirnen
Lámparas P21W

NEW



Ref	Kg	A	V	W	Emark	Article	Lot
79780251	0.028	P21W	24v	21w	E ₄	P21W - BA15s	1

Reg.UNE ECE R 37

H1 Lamps
H1 Lampen
Lámparas H1

NEW

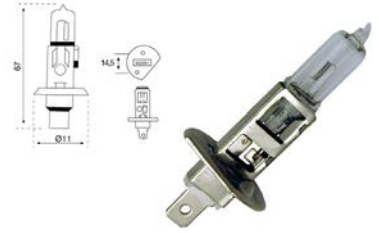

Ref	Kg	A	V	W	Emark	Article	Lot
79780231	0.02	H1	24v	75w	E ₄	H1 - P14.5s - 75W	1

Reg.UNE ECE R 37



Ref.	Pag.	Ref.	Pag.	Ref.	Pag.	Ref.	Pag.	Ref.	Pag.	Ref.	Pag.	Ref.	Pag.	Ref.	Pag.
0101003	56	0101385	58	0106090	73	0201195	120	0201597	106	0298001	126	0401226	187	0452524	301
0101005	56	0101391	58	0106092	74,111	0201196	119	0201598	108	0298002	126	0401229	187	0460115	299
0101007	56	0101393	60	0106094	74,111	0201198	119	0201599	108	0298004	117	0401231	187	0460125	299
0101010	56	0101398	60	0106131	71	0201412	109	0280015	91	0298011	116	0401232	187	0460180	299
0101013	56	0101440	61	0106147	75	0201414	109	0280016	91	0298012	126	0401233	187	0461115	299
0101017	58	0102016	63	0106148	75	0201430	109	0280017	91	0298020	115	0401235	187	0461125	299
0101020	56	0102020	63	0106150	76	0201441	104	0282101	89	0298022	116	0401236	187	0470115	298
0101021	56	0102025	63	0106155	76	0201442	104	0282103	89	0298024	116	0401237	187	0470125	298
0101022	56	0102054	63	0106258	70	0201443	104	0282105	89	0298026	116	0401238	187	0471115	298
0101024	56	0102056	63	0106260	70	0201444	106	0282107	89	0298030	125	0401239	187	0471116	298
0101025	56	0102058	63	0106273	70	0201445	106	0282109	89	0298032	126	0401240	187	0471125	298
0101026	56	0102094	62	0106275	70	0201446	106	0282147	92	0298034	117	0401244	187	0471230	298
0101027	56	0102096	62	0106358	70	0201450	107	0282150	91	0298035	117	0401245	187	0471231	298
0101030	56	0102098	62	0106360	70	0201451	107	0282151	91	0298036	117	0402102	317	0472115	298
0101032	56	0102099	62	0106373	70	0201452	108	0282152	91	0301238	140	0402104	317	0472125	298
0101033	56	0102100	63	0106375	70	0201453	104	0282153	92	0301240	140	0402106	317	0480001	313
0101034	56	0102120	63	0190002	58	0201454	105	0282154	91	0301241	140	0402112	317	0480002	313
0101038	56	0102138	63	0190005	58	0201455	108	0282155	91	0301242	140	0402114	317	0480005	313
0101039	56	0102156	63	0190071	56	0201456	107	0282156	91	0301243	140	0402116	317	0480006	313
0101040	56	0103010	57	0190072	58	0201457	105	0282157	91	0301244	140	0402140	317	0480007	313
0101042	56	0103012	57	0201010	138	0201458	107	0282158	91	0301246	140	0403004	318	0480008	313
0101043	56	0103014	57	0201012	138	0201459	108	0282159	91	0301248	140	0403006	318	0480009	313
0101045	56	0103016	57	0201014	138	0201460	108	0282160	91	0301249	140	0403008	318	0480010	313
0101046	56	0103020	57	0201016	138	0201461	105	0282161	91	0301250	140	0411500	302	0480011	313
0101047	56	0103022	57	0201018	138	0201462	105	0282162	91	0301270	140	0411501	302	0480030	308
0101048	56	0103024	57	0201019	138	0201464	106	0282163	91	0301272	140	0411502	302	0480031	308
0101081	58	0103026	57	0201020	138	0201470	112	0282164	91	0301276	140	0411536	301	0480032	308
0101105	58	0103028	57	0201022	138	0201471	112	0282165	91	0301278	140	0412500	302	0480040	314
0101120	59	0103030	57	0201024	138	0201474	112	0282167	91	0301430	140	0412501	302	0480041	314
0101121	59	0103032	57	0201026	138	0201475	112	0282180	94	0301432	140	0412502	302	0480050	310
0101122	59	0103034	57	0201028	138	0201481	113	0282182	94	0301434	140	0412536	301	0480051	310
0101123	59	0103036	57	0201029	138	0201483	113	0282230	124	0301610	140	0418000	302	0480060	315
0101124	59	0103038	57	0201050	425	0201485	113	0282232	124	0301612	140	0418001	302	0480061	315
0101125	59	0103040	57	0201052	425	0201489	113	0282300	88	0301614	140	0418002	302	0480070	315
0101126	59	0106010	72	0201054	425	0201494	111	0282302	90	0301615	140	0418036	301	0480080	314
0101127	59	0106014	69	0201056	425	0201495	125	0282306	93	0301616	140	0421536	301	0480081	314
0101128	59	0106015	69	0201057	425	0201496	125	0282308	93	0301617	140	0421560	301	0480082	314
0101129	59	0106016	69	0201058	425	0201498	111	0282320	90	0301618	140	0421580	301	0480083	312
0101130	59	0106017	69	0201059	425	0201500	125	0282322	88	0301620	140	0422536	301	0480100	312
0101131	59	0106020	71	0201060	424	0201548	106	0282324	93	0301622	140	0422560	301	0480120	309
0101132	59	0106030	72	0201062	424	0201549	106	0282326	90	0301624	140	0422580	301	0480213	309
0101133	59	0106032	73	0201064	424	0201550	104	0282328	93	0301626	140	0428036	301	0480215	309
0101134	59	0106034	69	0201068	424	0201551	104	0282340	88	0301628	140	0428080	301	0480217	309
0101135	59	0106035	71	0201070	424	0201560	104	0282344	90	0401004	186	0431560	301	0480220	309
0101136	59	0106037	69	0201072	424	0201561	104	0282346	93	0401006	186	0431580	301	0480222	309
0101202	60	0106040	71	0201074	424	0201564	107	0282348	93	0401008	186	0432560	301	0480415	309
0101205	60	0106041	71	0201078	424	0201565	107	0282360	88	0401010	186	0432580	301	0480417	309
0101214	60	0106042	69	0201080	424	0201566	109	0282364	90	0401012	186	0438080	301	0480712	311
0101216	60	0106043	69	0201082	424	0201567	109	0282401	96	0401014	186	0441540	300	0480812	312
0101220	60	0106045	71	0201160	123	0201568	108	0282412	96	0401016	186	0441560	300	0480912	311
0101224	60	0106046	71	0201164	123	0201569	108	0282416	96	0401020	186	0441580	300	0480913	311
0101230	60	0106058	76	0201174	121	0201570	105	0282418	96	0401022	186	0442540	300	0481012	311
0101232	60	0106059	76	0201176	123	0201571	105	0282420	96	0401026	186	0442560	300	0481122	312
0101252	61	0106064	75	0201177	123	0201580	108	0282422	96	0401027	186	0442580	300	0502002	35
0101262	61	0106066	75	0201182	123	0201581	108	0282424	96	0401150	187	0443540	300	0502007	36,36
0101266	61	0106067	75	0201183	123	0201584	105	0282426	96	0401155	187	0443560	300	0502008	36
0101282	61	0106069	75	0201184	123	0201585	105	0282430	101	0401158	187	0443580	300	0502009	36
0101284	61	0106070	73	0201188	122	0201590	105	0282432	101	0401160	187	0444540	300	0502019	29
0101348	57	0106080	73,171	0201189	121	0201591	105	0290006	99	0401163	187	0444560	300	0502024	30
0101358	57	0106082	72	0201191	121	0201594	108	0290036	100	0401165	187	0444580	300	0502031	29
0101361	57	0106086	72	0201192	120	0201595	108	0292105	97	0401170	187	0445540	299	0502043	28
0101366	58	0106087	72	0201194	119	0201596	106	0292106	98	0401221	187	0451524	301	0502061	31



REF. INDEX

Ref.	Pag.	Ref.	Pag.	Ref.	Pag.	Ref.	Pag.	Ref.	Pag.	Ref.	Pag.	Ref.	Pag.		
0502063	31	0601076	40	0801394	209	1001200	221	1201220	234	1203002	244	1303340	260	1402517	272
0502070	36	0601085	39	0801396	203	1001202	220	1201225	234	1203003	244	1303350	260	1402519	272
0502080	36	0601086	39	0801397	203	1001205	221	1201235	235	1203004	114	1303351	261	1402530	221
0502088	36	0601088	39	0801399	209	1001207	220	1201240	235	1203005	244	1303352	261	1402532	220
0502090	36	0601110	45	0802028	207	1001230	220	1201245	266	1203006	115	1303354	261	1402564	62
0502206	33	0601120	45	0802029	207	1001240	222	1201250	266	1203007	244	1303355	261	1403010	270
0502209	32	0601121	45	0802113	202	1001242	222	1201253	240	1203008	114	1303359	261	1403012	270
0502212	31	0601140	45	0802123	203	1001244	222	1201255	240	1203011	115	1303362	261	1403018	271
0502213	31	0601150	45	0802133	203	1001250	222	1201265	241	1203016	245	1306004	262	1403020	271
0502214	32	0601162	45	0802143	203	1001400	218	1201270	240	1203017	245	1306005	262	1403030	271
0502215	32	0601164	45	0802153	203	1001420	217	1201271	240	1203018	245	1306008	263	1404170	272
0502218	33	0601210	46	0901026	227	1001440	218	1201280	241	1203019	114	1306010	264	1404172	272
0502310	34	0601214	46	0901027	227	1002020	346	1201281	241	1203025	241	1306020	263	1404174	272
0502312	34	0601216	45	0901031	227	1002030	346	1201282	241	1203030	241	1306090	263	1404177	272
0502314	34	0601230	45	0901032	227	1002040	346	1201309	236	1203058	245	1306102	262	1404180	273
0502350	34	0801007	198	0901033	227	1002045	347	1201310	236	1203062	246	1306104	262	1404181	273
0502355	34	0801012	199	0901041	227	1002060	347	1201311	237	1203064	115	1306110	265	1404187	272
0502360	34	0801014	206	0901042	227	1002064	347	1201320	337	1203094	246	1306120	264	1404190	272
0502365	34	0801016	199	0901043	228	1002066	347	1201342	238	1204009	34	1306130	264	1404202	273
0502370	34	0801018	206	0901045	228	1101002	78	1201362	238	1204012	238	1306140	264	1490006	270
0502375	34	0801050	199	0901046	228	1101003	78	1201372	239	1204015	234	1306180	265	1492002	275
0502377	34	0801052	199	0901117	228	1101014	77	1201374	239	1204017	234	1306184	265	1493012	146
0502379	34	0801110	200	0901118	228	1101016	77	1201375	239	1204030	235	1306186	265	1501010	223
0502526	32	0801112	204	0901119	229	1101018	77	1201383	240	1204040	235	1306190	263	1501015	223
0502527	32	0801113	201	0901120	229	1101042	78	1201384	240	1204050	236	1401014	274	1501020	223
0502540	33	0801116	201	0901158	226	1101044	78	1201385	240	1204052	237	1401024	274	1501030	223
0502541	33	0801117	201	0901159	226	1101080	79	1201410	242	1204054	237	1401028	274	1501038	224
0502542	31	0801118	202	0901160	226	1101086	79	1201412	242	1204056	232,33	1401029	274	1501040	224
0502543	31	0801119	202	0901164	226	1102101	84	1201413	242	1204062	238	1401034	274	1501045	224
0502544	32	0801121	198	0901166	226	1102102	84	1201430	242	1301116	256	1401041	274	1501046	348
0502545	32	0801122	204	0901168	226	1102106	84	1201440	243	1301120	254	1401042	274	1501050	348
0505010	14	0801124	201	0901171	226	1102108	84	1201470	243	1301122	254	1401048	274	1501052	348
0505014	14	0801125	202	0901172	230	1102110	82	1201472	243	1301130	255	1401049	274	1501053	349
0505096	20	0801126	198	0901174	230	1102120	82	1201474	243	1301140	254	1401058	274	1501054	349
0505109	17	0801127	206	0901176	230	1102130	82	1202004	248	1301142	254	1401059	274	1501055	224
0505130	15	0801128	206	0901178	230	1102131	82	1202016	247	1301160	255	1401070	274	1501060	349
0505518	16	0801139	29	0901251	229	1102132	80	1202022	249	1301170	255	1401071	275	1501061	349
0505550	18	0801140	29	0901255	229	1102133	80	1202023	249	1302110	256	1401073	275,276	1501062	350
0505802	21	0801143	205	0902061	230	1102134	83	1202024	249	1302112	256	1401082	276	1501063	350
0505804	21	0801144	205	0902064	230	1102136	81	1202028	247	1302127	256	1401084	276	1501065	350
0506002	35	0801145	205	1001005	216	1102138	80	1202029	248	1302129	257	1401090	275	1501066	350
0506003	35	0801146	205	1001006	216	1102139	80	1202031	248	1302136	257	1402080	269	1501110	225
0506005	35	0801147	204	1001007	216	1102141	81	1202032	249	1302137	257	1402082	269	1501120	225
0506024	35	0801148	204	1001008	216	1102142	81	1202092	251	1302141	257	1402083	269	1501125	225
0506305	19	0801150	200	1001050	218	1102143	81	1202093	251	1302212	257	1402091	268	1501128	225
0508010	12	0801160	200	1001060	218	1102144	83	1202097	252	1302410	257	1402101	268	1601018	396
0508030	28	0801170	200	1001070	217	1102147	83	1202100	252	1303022	258	1402104	268	1601019	396
0508032	28	0801302	198	1001074	218	1102148	82	1202101	252	1303025	258	1402210	268	1601022	396
0508034	28	0801310	210	1001110	217	1102150	429	1202103	252	1303032	258	1402308	191	1601030	396
0508060	35	0801312	209	1001120	217	1102154	429	1202120	250	1303034	258	1402312	189	1601032	398
0508070	34	0801314	207	1001156	216	1102156	429	1202124	250	1303046	259	1402404	270	1601035	398
0508090	30	0801316	210	1001157	216	1201016	232	1202128	250	1303056	260	1402406	270	1601036	398
0508500	30	0801318	207	1001164	217	1201018	232	1202129	250	1303202	258	1402408	270	1601037	398
0508600	30	0801322	210	1001166	217	1201020	232	1202140	250	1303205	260	1402410	270	1601074	397
0601020	45	0801324	210	1001180	213	1201022	232	1202142	250	1303232	258	1402412	270	1601078	397
0601030	45	0801326	209	1001182	213	1201030	232	1202214	251	1303238	259	1402427	270	1601080	397
0601035	45	0801327	207	1001184	213	1201032	232	1202272	250	1303240	259	1402429	270	1601082	397
0601040	45	0801380	207	1001186	213	1201040	232	1202278	250	1303242	259	1402431	270	1601130	399
0601042	45	0801381	208	1001190	215	1201042	232	1202386	251	1303244	258	1402440	270	1601131	399
0601050	45	0801387	208	1001192	215	1201210	233	1202387	251	1303250	260	1402505	271	1601132	399
0601072	40	0801389	208	1001194	215	1201212	233	1202388	251	1303261	259	1402511	271	1601136	398
0601074	40	0801391	208	1001196	215	1201215	233	1203001	114	1303281	260	1402512	271	1601140	399



Ref.	Pag.	Ref.	Pag.	Ref.	Pag.	Ref.	Pag.	Ref.	Pag.	Ref.	Pag.	Ref.	Pag.		
1601141	399	1702025	165	1703254	184	2001050	144	2201071	404	2301205	333	2569100	195	2596070	366
1601142	399	1702026	165	1703256	184	2001060	144	2201076	405	2301206	333	2569101	195	2596071	366
1601172	399	1702030	165	1782113	95	2001070	142	2201084	405	2301208	333	2569102	195	2596072	367
1601174	400	1702032	165	1782114	95	2001072	142	2201086	406	2301209	334	2569103	194	2596073	367
1602020	401	1702034	165	1782116	95	2001080	144	2201152	191	2301210	333	2572001	417	2596076	367
1602030	401	1702038	165	1801030	189	2001081	144	2201158	191	2301212	336	2572002	417	2596077	367
1602122	401	1702041	165	1801120	189	2001110	147	2201159	191	2301214	334	2572004	418	2596078	361
1602138	401	1702042	165	1801122	189	2001112	147	2201160	191	2301216	334	2572008	419	2596079	361
1602226	402	1702043	165	1801130	190	2001114	147	2201170	192	2301217	341	2572009	419	2596080	361
1602230	402	1702047	165	1801132	190	2001116	147	2201172	192	2301219	341	2572010	417	2596081	361
1683004	192	1702052	167	1801184	190	2001126	148	2201178	192	2301220	338	2572012	419	2596082	363
1683006	192	1702053	173	1801300	190	2001170	148	2301025	320	2301223	338	2572013	419	2596083	363
1683010	192	1702054	167	1902036	150	2001172	148	2301026	320	2301228	341	2572015	419	2596084	364
1683012	192	1702055	171	1902037	150	2001174	148	2301027	320	2301234	345	2572016	419	2596085	363
1683014	192	1702059	169	1902041	151	2001176	148	2301028	322	2301236	336	2572025	418	2596086	363
1683018	192	1702060	167	1902042	151	2001180	149	2301030	321	2301238	345	2595800	365	2596087	363
1683022	192	1702062	167	1902046	150	2001182	149	2301032	321	2301242	342	2595994	356	2596088	363
1683024	192	1702065	168	1902049	152	2001210	145	2301034	321	2301244	343	2595996	357	2596089	363
1683026	192	1702066	167	1902050	152	2001216	145	2301036	321	2301246	342	2595998	357	2596090	363
1701004	161	1702068	167	1902051	152	2001224	145	2301064	321	2301247	342	2596005	357	2596093	362
1701005	161	1702082	166	1902052	153	2001240	146	2301065	321	2301248	344	2596007	358	2596094	362
1701007	161	1702086	166	1902056	150	2001246	146	2301072	322	2301249	344	2596009	358	2596096	362
1701008	162	1702094	168	1902058	151	2001434	134	2301076	326	2301250	344	2596011	358	2596110	364
1701009	161	1702096	171	1902060	153	2001435	134	2301078	326	2301251	343	2596012	366	2596112	364
1701010	162	1703010	174	1902070	153	2001436	134	2301082	323	2301252	344	2596016	367	2596114	364
1701012	161	1703015	174	1902082	154	2001438	134	2301083	323	2301253	344	2596019	375	2596116	364
1701036	159	1703020	174	1902086	154	2001442	131	2301086	323	2301309	339	2596020	375	2596118	364
1701038	159	1703025	174	1902092	154	2001443	131	2301090	322	2301316	339	2596021	375	2596120	364
1701040	160	1703030	175	1902300	155	2001445	135	2301091	322	2301318	339	2596022	376	2596200	377
1701042	160	1703064	175	1902304	155	2001446	135	2301093	326	2301362	340	2596024	360	2597012	360
1701044	160	1703110	183	1902320	155	2001447	131	2301094	326	2301365	340	2596025	376	2597014	368
1701045	159	1703120	176	1902322	155	2001455	130	2301095	325	2301370	340	2596026	376	2597015	368
1701046	159	1703130	178	1903002	427	2001460	132	2301096	325	2519003	154	2596027	376	2597016	368
1701047	160	1703132	178	1903004	427	2001462	132	2301097	325	2519004	154	2596031	378	2597018	368
1701060	158	1703150	176	1903012	427	2001486	136	2301098	326	2519005	154	2596032	377	2597046	379
1701062	158	1703158	175	1903014	427	2001487	136	2301101	328	2519006	154	2596033	378	2597048	379
1701064	158	1703160	176	1903022	426	2001488	136	2301103	330	2519008	154	2596034	377	2597050	379
1701101	157	1703162	175	1903024	426	2001520	135	2301110	329	2519011	152	2596036	362	2597052	380
1701102	157	1703164	176	1903032	426	2001544	131	2301120	328	2519013	151	2596037	362	2597054	380
1701121	157	1703166	178	1903034	426	2001546	130	2301121	327	2519017	153	2596038	362	2597056	380
1701122	157	1703168	179	1903100	428	2001547	132	2301124	328	2521011	296	2596039	362	2597072	380
1701123	157	1703170	177	1903110	428	2001549	132	2301125	328	2521012	296	2596040	361	2800516	283
1701124	157	1703172	177	1903111	428	2001559	135	2301128	328	2521013	296	2596042	361	2801512	283
1701141	157	1703175	177	1903120	428	2001563	133	2301130	336	2521016	296	2596043	365	2801516	283
1701142	157	1703180	178	1903130	428	2001565	133	2301131	336	2521090	296	2596044	365	2801520	283
1701143	157	1703183	180	1903200	428	2001568	133	2301132	331	2521094	296	2596046	361	2801620	283
1701144	157	1703184	180	1903300	428	2001569	137	2301134	337	2569001	352	2596048	359	2801712	283
1701161	157	1703186	180	1903400	428	2001570	133	2301136	329	2569005	352	2596050	359	2802520	280
1701162	157	1703189	180	1903500	428	2001580	136	2301138	336	2569008	353	2596052	357	2803008	279
1701181	157	1703190	177	1903600	428	2001584	133	2301140	335	2569009	353	2596053	357	2803412	280
1701182	157	1703192	179	1903700	428	2001585	133	2301142	335	2569010	354	2596056	359	2803418	280
1701183	157	1703206	182	1903800	428	2001586	137	2301144	335	2569012	354	2596057	359	2803512	280
1701184	157	1703208	182	1903900	428	2101030	295	2301150	330	2569015	354	2596058	359	2803516	280
1701185	157	1703212	181	2001012	142	2101096	166	2301157	331	2569017	354	2596060	355	2804012	282
1701186	157	1703214	181	2001015	142	2101134	166	2301158	331	2569018	354	2596061	355	2804806	279
1701187	157	1703216	182	2001020	143	2102021	295	2301160	331	2569020	194	2596062	355	2804808	279
1701188	157	1703220	181	2001022	143	2102025	295	2301162	331	2569022	194	2596064	359	2804810	279
1702002	165	1703222	181	2001024	143	2102049	295	2301164	331	2569024	195	2596065	355	2804812	279
1702010	165	1703230	183	2001030	143	2102052	295	2301170	332	2569026	195	2596066	359	2804814	279
1702012	171	1703232	183	2001032	143	2102102	166	2301172	332	2569030	193	2596067	358	2804816	279
1702020	165	1703234	183	2001040	144	2201060	404	2301201	330	2569032	193	2596068	358	2804818	279
1702024	165	1703252	184	2001042	144	2201062	404	2301204	330	2569034	194	2596069	356	2804820	279



REF. INDEX

Ref.	Pag.	Ref.	Pag.	Ref.	Pag.	Ref.	Pag.	Ref.	Pag.	Ref.	Pag.	Ref.	Pag.
2804822	279	2824845	285	2873517	284	2891653	291	6401190	440	6402177	439,440	6501178	447
2804825	279	2824850	285	2874812	284	2892546	291	6401191	440	6402187	440	6501179	447
2804828	279	2824855	285	2874816	284	2893546	291	6401192	440	6402188	440	6501214	447
2804830	279	2824860	285	2874825	284	2894836	292	6401193	440	6402190	440	6501228	448
2804835	279	2824865	285	2875510	284	2894839	292	6401194	441	6402192	440	6501230	448
2804840	279	2825512	285	2875516	284	2896439	292	6401196	441	6402193	440	6501232	448
2804845	279	2825516	285	2875525	284	2896441	292	6401199	441	6402194	441,441	6501235	449
2804850	279	2825520	285	2880001	303	2896442	292	6401225	433	6402196	440	6501320	449
2804855	279	2826435	285	2880002	303	2897966	292	6401227	434	6402199	441	6501332	449
2804860	279	2831516	282	2880003	303	2898054	290	6401228	433	6402225	433	6501341	449
2804920	279	2834806	282	2880004	303	6201040	453	6401229	433	6402227	433	6501390	446
2806010	279	2834808	282	2880005	307	6201050	453	6401230	433	6402230	433	6501401	449
2806012	279	2834810	282	2880006	307	6201070	453	6401232	433	6402232	433	6502030	452
2806014	279	2834812	282	2880007	305	6201110	453	6401234	433	6402233	433	6502032	452
2806016	279	2834814	282	2880008	304	6201120	454	6401235	434	6402234	433	6502040	451
2806018	279	2834816	282	2880009	305	6201130	454	6401236	433	6402236	433	6502041	451
2806020	279	2834818	282	2880010	305	6201140	454	6401237	434	6402238	434	6502042	451
2806022	279	2834820	282	2880011	307	6201150	454	6401238	434	6402240	433	6503001	450
2806026	279	2834822	282	2880012	305	6201160	455	6401240	433	6402246	434	6503010	450
2806030	279	2834825	282	2880013	306	6201410	455	6401243	434	6402248	434,434	6503011	450
2806412	279	2834830	282	2880014	306	6201420	455	6401270	442	6402273	442,444,445	6503020	450
2806415	279	2836012	282	2880015	306	6201546	457	6401273	442,444	6402275	442	6503030	450
2806418	279	2836015	282	2880148	304	6201548	457	6401274	442,445	6402276	442	6503040	450
2806422	279	2836018	282	2880160	304	6251510	456	6401275	442	6402277	442	6504001	430
2806426	279	2836412	282	2880164	304	6251512	456	6401276	442	6402281	442	6504002	430
2806430	279	2836415	282	2880248	303	6251520	457	6401277	442	6402286	443	6504003	430
2811416	281	2836418	282	2880264	303	6251530	456	6401281	443	6402330	444	6504004	430
2812518	281	2841610	289	2880348	303	6251532	456	6401282	443	6402335	444	6504005	430
2814010	280	2841612	289	2880364	303	6251535	456	6401287	443	6402340	444	6504006	430
2814808	280	2841614	289	2880400	304	6251536	457	6401289	443	6402344	444	6504007	430
2814810	280	2841616	289	2880401	304	6251538	456	6401310	444	6402346	444	6504008	430
2814812	280	2841617	289	2880564	306	6301020	458	6401320	444	6402347	444	6504009	431
2814814	280	2841618	289	2881520	287	6301050	458	6401327	444	6402374	436	6504010	431
2814816	280	2841620	289	2883512	287	6301060	458	6401328	444	6402384	435	6504011	431
2814818	280	2841623	289	2883516	287	6301110	458	6401329	444	6402385	436	6504012	431
2814820	280	2841816	289	2884811	287	6301120	458	6401330	444	6402415	435	6504013	431
2814824	280	2842515	288	2884812	287	6301130	458	6401331	444	6402416	436	6504014	431
2814828	280	2843614	289	2884818	287	6301330	458	6401365	435	6402418	435	6504015	431
2814830	280	2843620	289	2884825	287	6301335	458	6401366	435	6402425	435	6504016	431
2814835	280	2843623	289	2886416	287	6301340	458	6401374	436	6402429	435	6504017	432
2815014	281	2844814	288	2890001	294	6401020	437	6401375	435	6402430	435	6504018	432
2815020	281	2846023	288	2890002	294	6401060	437	6401377	435	6402432	435	6504501	450
2816016	280	2846314	288	2890003	293	6401070	437	6401379	436	6409001	436	6504502	450
2820512	286	2846414	288	2890004	294	6401072	437	6401380	435	6501022	447	6504503	450
2821516	286	2846420	288	2890006	293	6401075	437	6401381	435	6501045	447	6504504	450
2821520	286	2854808	281	2890010	293	6401076	437	6401382	435	6501046	448	6504505	450
2821524	286	2854810	281	2890011	293	6401078	437	6401384	435	6501048	448	6504506	450
2821535	286	2854812	281	2890012	293	6401079	437	6401385	436	6501050	447	6504520	451
2822518	286	2854814	281	2890018	293	6401080	438	6402020	437	6501077	448	6504540	417
2823520	286	2854816	281	2890019	294	6401082	438	6402050	437	6501078	448	6702012	413
2824520	285	2854818	281	2890020	294	6401132	439	6402052	437	6501079	448	6702014	413
2824810	285	2854820	281	2890021	293	6401150	439	6402054	437	6501080	449	6702018	412
2824812	285	2854825	281	2890022	294	6401160	439	6402056	437	6501081	449	6702020	412
2824814	285	2854830	281	2890023	293	6401180	439	6402057	438	6501115	446	6702026	412
2824816	285	2854835	281	2890030	293	6401181	439	6402060	437	6501116	446	6702040	413
2824818	285	2864814	288	2890031	293	6401182	439	6402062	438	6501117	446	6702044	413
2824820	285	2866414	288	2890032	293	6401184	439	6402132	439	6501118	446	6702046	414
2824822	285	2866420	288	2890033	293	6401185	440	6402140	439	6501119	446	6702048	414
2824825	285	2871516	284	2890164	291	6401186	439	6402150	439	6501120	446	6702052	414
2824830	285	2872512	284	2890248	291	6401187	440	6402170	439	6501121	446	6702054	414
2824835	285	2873512	284	2890348	291	6401188	440	6402172	439	6501160	447	6702056	414
2824840	285	2873515	284	2891081	292	6401189	440	6402174	439,440	6501175	447	6702112	409
												6702116	409
												6702117	409
												6702118	409
												6702120	410
												6702132	410
												6702134	410
												6704054	460
												6705052	460
												6801310	68
												6801315	68
												6801510	67
												6801512	67
												6801514	67
												6801516	67
												6801518	67
												6801520	67
												6801540	66
												6801542	66
												6801544	66
												6801546	66
												6801548	66
												6801550	66
												6801552	66
												6801562	67
												6801564	67
												6801566	67
												6801568	67
												6801570	67
												6801580	67
												6801582	67
												6801584	67
												6801586	67
												6801588	67
												6801590	67
												6801592	67
												6801602	68
												6801604	68
												6801606	68
												6801608	68
												6801680	66
												6801682	66
												6801684	66
												6801686	66
												6801688	66
												6801690	66



Ref.	Pag.	Ref.	Pag.	Ref.	Pag.	Ref.	Pag.
7201013	388	7205019	416	9606005	371	79040951	459
7201014	387	7205021	415	9606016	372	79040956	459
7201016	387	7205032	420	9607009	370	79040961	459
7201023	387	7205033	420	9607016	372	79040967	459
7201024	387	7205034	420	9611245	369	79040971	459
7201025	388	7205036	420	9611272	371	79323303	459
7201026	388	7205037	421	9612245	369	79323304	459
7201027	389	7205038	421	9612272	371	79323342	459
7201028	391	7205040	421	9613272	371	79610003	128
7201029	389	7205042	421	9613285	374	79610005	128
7201031	391	7205045	422	9698050	366	79620032	408
7201032	389,392	7205046	422	9698052	366	79780207	462
7201034	389	7206010	173	9698054	367	79780217	462
7201036	389	7290001	416	9698056	355	79780231	462
7201040	389	7401544	384	9698062	360	79780251	462
7201050	390	7401545	384	9698064	358		
7201051	390	7403001	385	9698066	358		
7201053	390	7403005	384	9698068	358		
7201055	390	7403272	383	9698070	358		
7201056	390	7403273	382	9698072	356		
7201059	390	7423272	382	9698082	360		
7202050	394	7433272	383	9701013	370		
7202060	392	7439272	383	9702013	370		
7202064	392	7474244	381	9703013	370		
7202067	392	9401005	384	9703016	372,374		
7202068	392	9401141	381,385	9704016	369,372,374		
7202071	392	9401261	382	9709016	369,371,372		
7202072	392	9401270	383	9710016	369,371,372		
7202074	392	9401272	383	9711005	371		
7202076	392	9401286	382,385	9711013	370		
7202080	393	9401544	384	9712005	371		
7202082	393	9403011	385	9713013	370		
7202084	393	9403141	381,385	9721008	369		
7202086	393	9403272	383	9722008	369		
7202088	393	9403273	382	9723010	373		
7202090	393	9403544	384	9723016	369,371,372		
7202092	393	9406272	383	9733016	369,371,372		
7202094	393	9421261	386,382	9793003	373,374		
7202096	393	9423141	381,384,386	9793009	369,370,373		
7202102	128	9423272	383	9797009	371		
7202106	127	9426274	383	9841248	369		
7202108	127	9451246	381,386	9842248	369		
7202110	127	9470151	381,382,384,386	9861016	372		
7202112	128	9470200	385	9862016	372		
7202114	127	9470205	385	70110003	408		
7202123	129	9470210	385	70110021	461		
7202125	129	9470215	386	70113901	408		
7202184	110	9470235	381,386	70177893	460		
7202185	110	9470260	382,386	70177894	460		
7202186	110	9470500	385	70310005	460		
7202188	110	9475246	381	70429518	461		
7205001	410	9477282	381,384,386	70429520	461		
7205002	411	9601016	372	70537835	461		
7205003	411	9601026	371	70570010	461		
7205004	411	9601101	373	70570011	461		
7205005	411	9602016	372	70570012	461		
7205006	412	9602026	371	70570013	461		
7205008	415	9602101	373	70623217	460		
7205009	415	9602248	370	71729901	460		
7205012	415	9603013	373	72512701	461		
7205014	415	9603245	369	72512795	461		
7205015	415	9605005	371	72512797	461		

SALES CONDITIONS

1- Conclusion of the contract.

Any purchase order of products implies unreserved adherence to the present general conditions of sale, completed or adapted by our special conditions, which would cancel any contrary clause that may appear in the purchase orders, purchase conditions or any other commercial documents.

2- Payment.

Unless otherwise agreed, invoices are payable on the due date indicated on the invoice.

In case of delay in the payment, the seller may suspend all orders in progress.

Any sum not paid at maturity shown on the invoice will automatically entails the application of expenses and interest, notwithstanding the compensation for damages that could be claimed.

3- Deliveries.

Delivery times are always given as an indication. They cannot constitute a commitment nor create grounds for penalties or damages in case of delay on the scheduled dates.

Delivery times are indicated according to the availability of supply and according to the amount of the order.

In case of anomalies in transport (open packages, beaten or missing packages), they must be indicated in the carrier's delivery note.

4- Acceptance of the goods.

The Buyer shall be deemed to have accepted Goods 24 hours after delivery to the Buyer.

After acceptance the Buyer shall not be entitled to reject Goods which are in accordance with the contract.

5- Sellers Clause excluding liability for delay in delivery

The Seller shall not be liable for any loss or damage whatever due to failure by the Seller to deliver the Goods (or any of them) promptly or at all.

Notwithstanding that the Seller may have delayed or failed to deliver the Goods (or any of them) promptly the Buyer shall be bound to accept delivery and to pay for the Goods in full.

6- Seller's retention of property

The Goods shall be at the Buyer's risk as from delivery

In spite of delivery having been made, property in the Goods shall not pass from the Seller until:

- the Buyer shall have paid the Price plus VAT in full; and
- no other sums whatever shall be due from the Buyer to the Seller

7- Warranty

The seller will take care of the execution of the order and the quality of the products. In case of defect recognized by the seller, the obligation of the latter will be limited to the replacement or the reimbursement of the defective quantities, without any other indemnity.

The warranty does not cover defects and damages resulting from storage, handling, transport or use in abnormal or non-conforming conditions with the nature, the prescriptions, and the suitability for use of the product.

8- RETURN MATERIAL PROCEDURE:

In the event of a non-conformity or return, the next procedure will be followed, as long as the goods have been bought neither as a clearance item, nor in a period of more than two years and are not discontinued:

1º. - An authorization to return any kind of material has to be requested to the Head Offices of ADAICO TRUCK AND TRAILER S.L. by email: export@adaico.com or fax: +34948314341

2º.- It is indispensable to indicate the article number, the amount, date of sale (providing order number or invoice number) and the reason for return (identified defect).

Return Authorization shall be made in written form. That means that no request done by telephone or in a commercial visit will be considered.

Any material WITHOUT prior AUTHORIZATION WILL NOT BE ACCEPTED BY THE WAREHOUSE and will be immediately rejected.

No return will be allowed if the mentioned requirements are not properly met.

9- Possible product return cases:

9.1.-PRODUCT WITH MANUFACTURING DEFECT:

After receiving the completed and accepted authorization request for returning the goods, the shipment of the defective material will be carried out only by the forwarder designated by ADAICO TRUCK AND TRAILER S.L. and carriage forward.

9.2.- DAMAGED MATERIAL DURING ITS TRANSPORT:

Any damaged or lost material must be notified to the forwarder and also to ADAICO within the next 24 hours. In the opposite case ADAICO will not credit any kind of broken or lost material outside our facilities. That is why we kindly ask you to inspect the goods at the time of reception. If it is not feasible please write down the following remark before signing the delivery note: INSPECTION PENDING. This is not valid as a claim for damage or lost without the subsequent telephonic notification within the next 24 hours.

9.3.- MATERIAL IN GOOD CONDITIONS:

Material in good conditions or with proper functioning will not be accepted since the orders are binding purchases and it should be understood as such.

In case of acceptance due to the customer requirements, the product will be depreciated in at least 20% of its price, as handling expenses.

Return shall be carried out through the transport company indicated by our customer service.

10- General exclusion of Seller's liability for indirect loss

The Seller shall be under no liability whatever to the Buyer for any indirect loss and/or expense (including loss of profit) suffered by the Buyer arising out of a breach by the Seller of this contract.

11- General limitation of Seller's liability

In the event of any breach of this contract by the Seller, the remedies of the Buyer shall be limited to damages on its own products. Under no circumstances shall the liability of the Seller exceed the Price of the Goods.

12- Proper law of contract.

The parties submit to the exclusive jurisdiction of the courts of Pamplona, Spain.

VERKAUFSBEDINGUNGEN

1- Vertragsabschluss.

Jede Bestellung von Produkten schließt die uneingeschränkte Einhaltung der vorliegenden allgemeinen Verkaufsbedingungen ein, die durch unsere besonderen Bedingungen ergänzt oder vervollständigt werden, und schließt jede anderslautende Klausel aus Bestellungen wie Einkaufsbedingungen oder sonstigen Handelsvorschriften aus.

2- Zahlung.

Soweit nicht anders vereinbart, sind Rechnungen auf bis zu dem in der Rechnung angegebenen Fälligkeitsdatum zahlbar.

Im Falle einer Zahlungsverzögerung kann der Verkäufer alle laufenden Aufträge aussetzen.

Eine Summe, die nicht auf Fälligkeit gezahlt wird, bringt automatisch Aufwendungen und Zinsen mit sich, ungeachtet der Schadensersatzklage die geltend gemacht wird.

3- Lieferungen.

Lieferzeiten sind immer rein Informativ angegeben. Sie können keine Verpflichtung darstellen und im Falle einer Verspätung zu den geplanten Terminen keine Strafen oder Schadensersatzansprüche begründen.

Die Lieferzeiten sind nach der Verfügbarkeit der Lieferung und nach dem Betrag der Bestellung angegeben.

Bei Anomalien im Transport (offene Pakete, angeschlagen oder fehlende Pakete) sind diese im Lieferschein des Frachtführers anzugeben.

4- Annahme der Ware.

Der Käufer ist verpflichtet, die Ware 24 Stunden nach Ablieferung zu akzeptieren.

Nach Abnahme ist der Käufer nicht berechtigt, Waren, die dem Vertrag entsprechen, zurückzuweisen.

5- Verkäufer-Klausel ohne Haftung für Lieferverzug.

Der Verkäufer haftet nicht für irgendwelche Verluste oder Schäden, die auf das Versäumnis des Verkäufers zurückzuführen sind, die Waren (oder einige von ihnen) unverzüglich oder gar nicht zu liefern.

Unbeschadet der Tatsache, dass der Verkäufer die Waren (oder einige von ihnen) verzögert versendet oder versäumt hat zu versenden, ist der Käufer verpflichtet, die Lieferung zu akzeptieren und die Ware vollständig zu bezahlen.

6- Eigentumsvorbehalt des Verkäufers.

Die Ware geht ab Lieferung auf Gefahr des Käufers über.

Trotz erfolgter Lieferung besteht solange das Eigentum an der Ware nicht beim Käufer bis:

- der Käufer den Preis zuzüglich der gesetzlichen Mehrwertsteuer vollständig bezahlt hat, und
- durch den Käufer keine weiteren Beträge an den Verkäufer offen sind.

7- Garantie.

Der Verkäufer achtet auf Ausführung der Bestellung und die Qualität seiner Produkte. Im Falle eines vom Verkäufer anerkannten Mangels ist die Verpflichtung des letzteren auf den Ersatz oder die Erstattung der mangelhaften Mengen ohne sonstige Entschädigung beschränkt.

Die Gewährleistung erstreckt sich nicht auf Mängel und Schäden, die durch Lagerung, Handhabung, Transport oder Verwendung bei anomalen oder nichtkonformen Bedingungen in der Art, die den Vorschriften und der Gebrauchstauglichkeit des Produkts entgegen entstehen.

8- Warenrückgabe-Verfahren.

Im Falle einer Nichtkonformität oder Rücksendung von Waren wird das folgende Verfahren eingehalten, solange die Ware weder als Freigabeposten noch in einem Zeitraum von mehr als ununterbrochen zwei Jahren gekauft wurde:

1º. – Von der Hauptverwaltung von ADAICO TRUCK AND TRAILER S.L. ist eine Genehmigung zur Rückgabe jeglicher Art von Material erforderlich. Per Email durch: export@adaico.com oder Fax: +34 948 314341

2º.- Es ist unentbehrlich, die Artikelnummer, den Betrag, das Kaufdatum, die Bestellnummer (oder die Rechnungsnummer) und den Grund für die Rücksendung (identifizierter Mangel) anzugeben.

Die Meldung zur Rücksendung hat schriftlich zu erfolgen. Das bedeutet, dass rein telefonischer Kontakt oder auch persönliches Erscheinen nicht akzeptiert wird.

Jede Rücksendung von Material OHNE vorherige AUTORISIERUNG WIRD NICHT VOM WARENEINGANG ANGENOMMEN und sofort abgelehnt.

Es wird keine Rückgabe gewährt, wenn die genannten Anforderungen nicht ordnungsgemäß erfüllt sind.

9- Mögliche Fälle von Rücksendungen:

9.1.-PRODUKT MIT HERSTELLUNGSFEHLER:

Nach Erhalt der ausgefüllten und anerkannten Genehmigungsanforderung für die Rücksendung der Ware erfolgt die Versendung des defekten Materials nur durch den von ADAICO TRUCK AND TRAILER S.L. genehmigten Spediteurs.

9.2.-Transportschäden:

Beschädigtes oder verlorenes Material muss dem Spediteur und auch ADAICO innerhalb der nächsten 24 Stunden mitgeteilt werden. Im umgekehrten Fall wird ADAICO keine Art von beschädigtem oder verlorenem Material außerhalb unserer Verantwortung akzeptieren. Deshalb bitten wir Sie, die Ware zum Zeitpunkt des Wareneingangs zu kontrollieren. Wenn es nicht möglich ist, notieren Sie bitte die folgende Bemerkung, bevor Sie den Lieferschein unterschreiben: ÜBERPRÜFUNG STEHT NOCH AUS. Dies gilt nicht als Schadensersatzanspruch ohne vorherige telefonische Mitteilung innerhalb der nächsten 24 Stunden.

9.3.- MATERIAL IN GUTEM ZUSTAND:

Eine Rücksendung von Material in gutem Zustand oder mit ordnungsgemäßen Funktionen wird nicht akzeptiert, da die Aufträge bindende Käufe und es als solche zu verstehen sind.

Im Falle dennoch der Annahme aufgrund von Kundenforderungen wird das Produkt in mindestens 20% seines Preises als Abwicklungskosten abgeschrieben.

Die Rücksendung erfolgt durch das von unserem Kundendienst angegebene Transportunternehmen.

10. Allgemeiner Ausschluss der Haftung des Verkäufers für indirekten Schaden.

Der Verkäufer haftet dem Käufer nicht für indirekte Verluste und / oder Aufwendungen (einschließlich Verlust des Gewinns), die dem Käufer entstanden sind, die sich aus einer Verletzung des Verkäufers dieses Vertrages ergeben.

11 - Allgemeine Beschränkung der Haftung des Verkäufers

Im Falle einer Verletzung dieses Vertrages durch den Verkäufer sind die Abhilfemaßnahmen des Käufers auf Schäden an eigenen Produkten beschränkt. Die Haftung des Verkäufers übersteigt unter keinen Umständen den Preis der Ware.

12- Ordnungsgemäßes Vertragsrecht

Die Parteien unterwerfen sich der ausschließlichen Zuständigkeit der Gerichte von Pamplona, Spanien.

CONDICIONES DE VENTA

1- Conclusión del contrato.

Cualquier orden de compra implica la adhesión incondicional al presente contrato de condiciones generales de venta, completado o adaptado por nuestras condiciones especiales, que cancelarían cualquier cláusula contraria que pudiera aparecer en las órdenes de compra, condiciones de compra o cualquier otro documento comercial.

2- Pago.

A menos que se acuerde otra cosa, las facturas son pagaderas en la fecha de vencimiento indicada en la factura.

En caso de retraso en el pago, el vendedor se reserva el derecho a suspender el resto de pedidos en curso.

Cualquier suma indicada en la factura que no sea pagada al vencimiento, conllevará automáticamente la aplicación de intereses y gastos sin perjuicio de la compensación por daños que pudiera ser reclamada.

3- Envíos.

Los plazos de entrega se ofrecen a modo de indicación. No constituyen compromiso ni constituyen motivo de penalización o perjuicio en caso de retraso en las fechas programadas.

Los plazos de entrega se indican de acuerdo a la disponibilidad y al importe del pedido.

En caso de anomalías en el transporte (paquetes abiertos, golpeados o desaparecidos), hay que hacerlo constar en la nota de entrega del transportista.

4- Aceptación de la mercancía.

Se considerará que el Comprador ha aceptado el material transcurridas 24 horas después de la entrega del mismo.

Tras la aceptación, el Comprador no tendrá derecho a rechazar la mercancía que esté de acuerdo al contrato.

5- Cláusula del vendedor excluyendo responsabilidad por demora en la entrega

El vendedor no será responsable por ningún daño o perjuicio derivado del incumplimiento de entregar el material (o parte del mismo) en la fecha requerida.

Sin perjuicio de que el vendedor se haya retrasado o no haya cumplido con la entrega de la mercancía en la fecha solicitada, el Comprador deberá aceptar el envío y pagar el material íntegramente.

6- Reserva de propiedad del vendedor

La mercancía estará bajo responsabilidad del comprador desde la entrega.

A pesar de haber realizado el envío, la propiedad del material no se transfiere del Vendedor hasta:

- que el Comprador haya pagado el precio + impuestos íntegramente; y
- que otras cantidades no sean debidas por parte del comprador al vendedor

7- Garantía

El Vendedor se encargará de la ejecución del pedido y de la Calidad de los productos. En caso de defecto reconocido por el Vendedor, la obligación de éste estará limitada al reemplazo o reembolso de la cantidad defectuosa, sin ninguna otra indemnización.

La garantía no cubre defectos y daños resultantes del almacenamiento, manipulación, transporte o uso en condiciones anormales o no conformes con la naturaleza, las prescripciones y la idoneidad para el uso del producto.

8- Procedimiento de devolución de material

Cuando se produzca una No Conformidad o Devolución por parte del cliente, se deberá proceder de la siguiente manera, siempre y cuando la mercancía no haya sido comprada en liquidación, ni en un plazo de superior a dos años y no se encuentre descatalogada:

1º.- Se deberá solicitar autorización para devolver cualquier clase de material a las oficinas centrales de ADAICO TRUCK AND TRAILER S.L. por email

- Nacional: ventas@adaico.com

- Internacional: export@adaico.com

o por fax (+34 948 314 341)

2º.- Será imprescindible indicar la referencia del producto, la cantidad, fecha de venta (aportando nr. de pedido y/o Factura) y el motivo de la devolución (defecto).

La autorización de la devolución se hará siempre por escrito a la oficina, es decir, no se considerará como conforme ninguna aceptación realizada telefónicamente ni en la visita comercial.

Cualquier material devuelto SIN AUTORIZACION previa NO SE ACEPTARA POR PARTE DE NUESTRO ALMACEN y quedará automáticamente rechazado.

No se procederá a autorizar ninguna devolución que no cumpla estos requisitos adecuadamente.

9- Posibles casos de devolución:

9.1.- MATERIAL CON DEFECTO DE FÁBRICACION:

Tras la solicitud de autorización de devolución perfectamente cumplimentada y aceptada, el envío del material deberá producirse a portes debidos, es decir, a cargo de ADAICO TRUCK AND TRAILER S.L. únicamente por la agencia de transporte que se designe en la aceptación de devolución.

9.2.- MATERIAL DAÑADO POR EL TRANSPORTE:

Cualquier material dañado o perdido deberá ser notificado tanto al transporte como a ADAICO en el momento de su entrega. En caso contrario ADAICO no se hará cargo del abono de ningún tipo de material dañado o perdido fuera de nuestras instalaciones, por lo que les rogamos revisen toda la mercancía en el momento de la recepción. Cuando no sea posible la revisión de la mercancía antes de firmar en el talón del transporte, por favor indiquen en observaciones del talón de entrega: PENDIENTE DE REVISIÓN, lo cual no indica, en ningún caso, que sea válido como reclamación por rotura o pérdida sin su posterior notificación telefónica o por email dentro de las 24h posteriores a su entrega.

9.3.- MATERIAL EN BUEN ESTADO:

No se aceptará la devolución de material en buen estado o uso correcto, ya que las compras se realizan en firme y como tal deben entenderse.

En caso de aceptación por exigencia del cliente se depreciará un mínimo del 20% en concepto de gastos de manipulación. La devolución de material debe efectuarse por el medio de transporte que indique nuestro departamento de atención al cliente.

10 – Exclusión general de la responsabilidad del Vendedor por pérdidas indirectas.

El vendedor no será responsable ante el comprador por ningún gasto o perjuicio indirecto (inclusive la pérdida de beneficios) sufridas por el comprador como consecuencia de un incumplimiento de este contrato.

11- Limitación general de responsabilidad del vendedor.

En caso de incumplimiento de contrato por parte del vendedor, los recursos del comprador se limitarán a los daños en sus propios productos. Bajo ninguna circunstancia excederá la responsabilidad del vendedor el precio de los productos.

12- Ley que rige el presente contrato.

Las partes se someten a la jurisdicción exclusiva de los tribunales de Pamplona, España.



ADAICO TRUCK & TRAILER, S.L.

OFICINAS / HEADQUARTERS

Tudela 64 - Ciudad del transporte
31119 Imarcoain (Navarra)

ESPAÑA - SPAIN

Loc: 42° 43' 36.67" N, 1° 36' 47.79" W

España: Tel. +34 948 314 313

Fax. +34 948 314 341

e-mail: ventas@adaico.com

Export: Tel. +34 948 314 328

e-mail: export@adaico.com

ALMACÉN / WAREHOUSE

P.E.Boroa 2BH 4-5

48340 Amorebieta (Bizkaia)

ESPAÑA - SPAIN

Loc: 43° 14' 8.24" N, 2° 45' 32.60" W

ADAICO LDA.

ESCRITÓRIO E ARMAZÉM

Rua Velha Vilar do Senhor, 819

4470 - Vila Nova da Telha

Maia - PORTUGAL

Loc: 41° 14' 55.47" N, 8° 41' 2.11" W

Tel. +351 22 941 06 07

Fax. +351 22 941 06 11

e-mail: portugal@adaico.com

ADAICO TRUCK & TRAILER, SASU

BUREAUX ET MAGASIN

Zone industrielle de la Plaine

Rue Charles Nungesser

42340-Veauche

Loire - FRANCE

Loc: 45° 32' 50" N, 4° 18' 25" E

Tel. (+33) 04 88 60 53 90

e-mail: adaico.sarl@adaico.com

ADAKYTT

FACTORY

昆山久运卡车零配件有限公司

50 North Gongmao Road, Luyang

Block, Zhoushi Town

Kunshan, Jiangsu - CHINA

江苏省昆山市周市镇陆杨街道

工茂路50号

Tel. +86-512-86160593

Fax. +86-512-86160597

e-mail: trucksales@kytt.com.cn

ADAICO S.A.S.

OFICINAS Y ALMACÉN

CL 17A N° 69B-95

Zona Industrial Montevideo,

Bogotá D.C.

COLOMBIA

Loc: 4° 38' 51.4" N, 74° 7' 25.9" W

Tel. +57 601 744 3313

e-mail: adaico.sas@adaico.com

ADAICO TRUCK & TRAILER S.A.C.

OFICINAS Y ALMACÉN

Jr. Antenor Orrego 2188,

Urb. Chacra Ríos Sur

Lima - PERÚ

Loc: 12° 3' 40.784400" S, 76° 58'

45.285600" W

Tel. +51 953 505 922

e-mail: adaico.sac@adaico.com

