

Specifications

Model	S-60 J	
Measurements	US	Metric
Working height*	66 ft 10 in	20.5 m
Platform height	60 ft 10 in	18.5 m
Horizontal reach	40 ft 6 in	12.3 m
A Platform length - 8 ft model	3 ft	0.91 m
Platform length - 6 ft model	2 ft 6 in	0.76 m
B Platform width - 8 ft model	8 ft	2.44 m
Platform width - 6 ft model	6 ft	1.83 m
C Height - stowed	8 ft 10 in	2.69 m
D Length, stowed (working)	31 ft 10 in	9.70 m
Length, transport (jib tucked)	23 ft 6 in	7.16 m
E Width	8 ft 2 in	2.49 m
F Wheelbase	8 ft	2.44 m
G Ground clearance, center	1 ft 10 in	56.4 cm

Productivity

Maximum lift capacity unrestricted	660 lb	300 kg
Maximum lift capacity restricted	N/A	
Platform rotation	160°	
Turntable rotation	353°, non-continuous	
Turntable tailswing (stowed)	5 ft 2 in	1.57 m
Vertical Jib Rotation - Up	75°	
- Down	55°	
Horizontal Jib Rotation	N/A	
Drive speed - stowed	3 mph	4.82 km/h
- elevated	0.68 mph	1.09 km/h
Gradeability - stowed	45%	45%
Turning radius: inside	8 ft 1 in	2.46 m
outside	18 ft 5 in	5.61 m
Maximum slope rating, counterweight uphill / downhill	45% / 25%	
Maximum sideslope rating	25%	
Controls	12V DC proportional	
Tires, std	315/55D20	

Power

Power source	Kubota Diesel, D1105-E4B, 3-cyl. diesel, 24 hp
	Kubota Diesel, D1803-CR-TIE4, 3-cyl. turbo diesel, 49 hp
	Deutz ROW, D2011 L03i, 3-cyl. diesel, 49 hp
Hydraulic tank capacity	21 gal / 79 liters
Hydraulic system capacity	25 gal / 95 liters
Fuel tank capacity	30 gal / 114 liters

Weight**	16,650 lb	7,550 kg
----------	-----------	----------

Standards Compliance	ANSI A92.2, CSA C225, EN 280, AS 1418.10
----------------------	--

* The metric equivalent of working height adds 2 m to platform height. U.S. adds 6 ft to platform height.
** Weight will vary depending on options and/or country standards.

Range Of Motion S-60 J

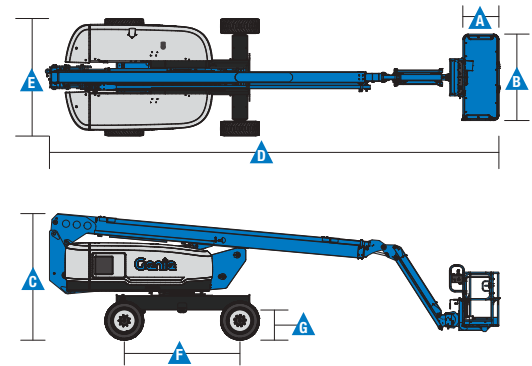
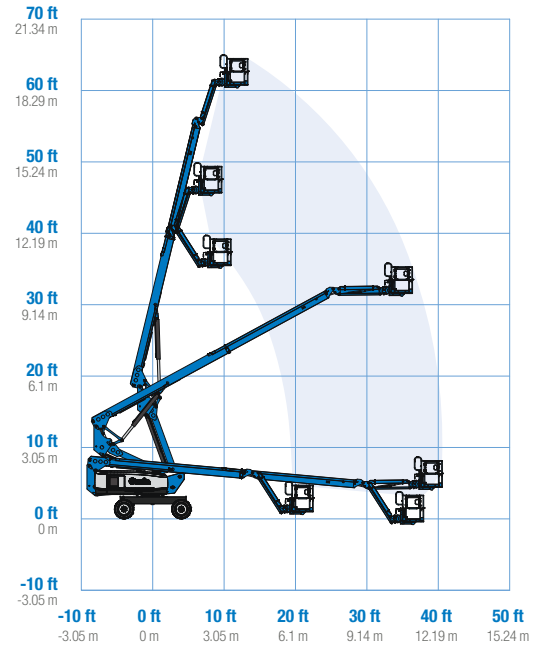

Features

Standard Features

Measurements

S-60 J

- 66 ft 10 in (20.5 m) working height
- 40 ft 6 in (12.3 m) horizontal reach
- 660 lbs (300 kg) lift capacity

Productivity

- Self-leveling platform
- 6 ft (1.83 m) jib boom
- 160° hydraulic platform rotation
- Proportional joystick controls
- Drive enable
- AC power cord to platform
- Horn
- Hour meter
- Tilt alarm
- Descent alarm
- 353° non-continuous turntable rotation
- Locking turntable covers
- Positive Traction Drive
- Two speed wheel motors
- Telematics ready connector
- Entry Toeboard
- Lift Guard™ Contact Alarm
- Hydraulic oil cooler

Power

- 12 V DC auxiliary power
- Anti-restart engine protection
- Auto engine fault shutdown

Drive

- 4WD (standard)
- Active oscillation

Easily Configured To Meet Your Needs

Platform Options

- Steel 8 ft (2.44 m) tri entry with side swing gate (standard)
- Steel 6 ft (1.83 m) dual entry with side swing gate

Engine Options

- Kubota Diesel, 3-cyl. diesel, 24 hp
- Kubota Diesel, 3-cyl. turbo diesel, 49 hp
- Deutz ROW, 3-cyl. diesel, 49 hp

Tire Options

- Rough terrain foam-filled (standard)
- Rough terrain non-marking (foam-filled)

Options & Accessories

Productivity Options

- Lift Guard Platform Mesh - Half
- Lift Guard Platform Mesh - Full
- Platform top auxiliary rail
- Lift Power™
 - 3 kW AC Generator
 - 12 kW 240 V / 60 Hz Welder Ready package
 - 12 kW Welder Equipped, Select Lincoln or Miller (12 kW options include a fire extinguisher and fireproof sleeves)
- Air line to platform
- Specialty hydraulic oil (cold weather, fire resistant, or biodegradable)
- Hostile environment kit
- Deluxe hostile environment kit
- Aircraft protection package (6 ft platform only)
- Thumb rocker steer
- Alarm package
- Panel cradle package
- Work light package
- Fall Arrest Bar

Power Options

- Cold Weather Packages
- Intake air pre-cleaner
- Positive Air Shutoff System



Genie United States

6464 185th Ave. NE
Redmond, WA 98052
Telephone +1 (425) 881-1800
Toll Free in USA/Canada +1 (800)-536-1800
Fax +1 (425) 883-3475

Distributed By: