

FitStay 1

Indulge your guests in a wellness oasis with the FitStay 1 Outdoor Fitness Park. Exclusively designed for hotels, this outdoor fitness facility is a testament to luxury and sophistication. From cardio machines to strength training equipment, FitStay 1 provides an unparalleled fitness journey where guests can invigorate their bodies while immersing themselves in the serene ambiance of your hotel.

Attributes

| | |
|--------------|------------|
| Product code | 1-3-257 |
| Certificate | EN 16630 |
| Age group | 14 + years |
| Designed for | Hotels |
| Capacity | 16 people |
| Fall height | 0.95 m |

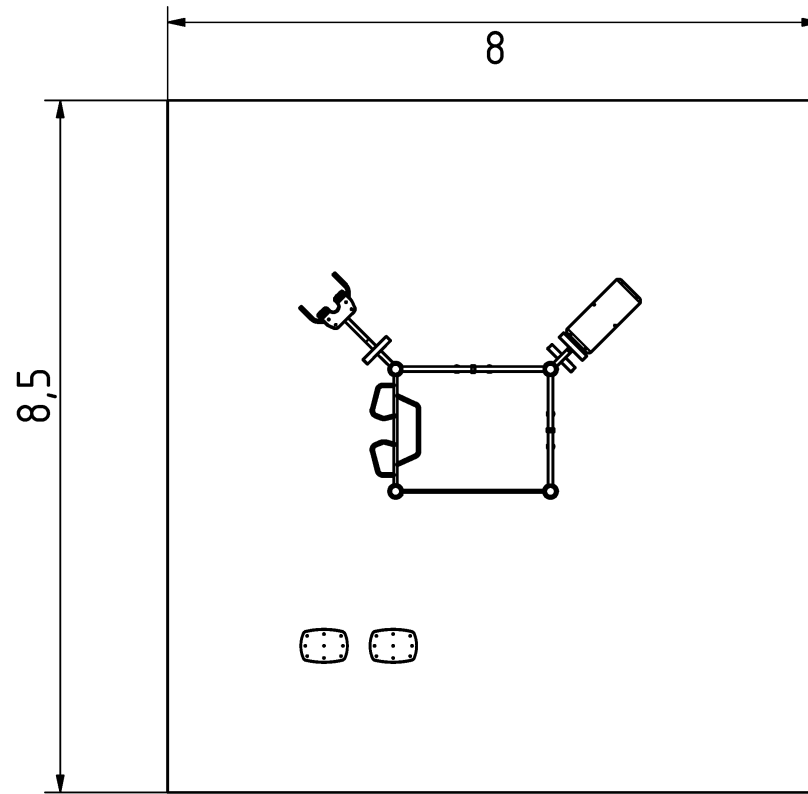

Technical specification

Anchoring option

Net weight

Material

Anti-corrosion possibility

Total Area

Color options

For more color options, discuss with your sales representative.

In-ground or surface

355 kg

S235

Galvanized or EPD

68 m²



Warranty

Structure

Steel

Paint

Plastic

Rubber

Moving parts

Detailed information in the warranty document

25-15 years

5-10 years

2 years

5-10 years

1-3 years

2 years