

# SELECTION 2024

## CELEBRATING SPECIAL OCCASIONS



Lighters  
**BIC® EZ Reach™** -  
light up unique  
moments.

Sustainable Gifts  
**Thoughtful**  
sustainable gifts  
for every occasion.

**BIC® Collection Boxes**  
Endless options  
for personalised  
gifts.

---

## Exploring BIC Graphic

# OUR STORY

The division of the BIC Group dedicated to personalising BIC® products, based in Tarragona, Spain since 1995.

Renowned for its innovation and quality, **BIC Graphic upholds the iconic BIC® brand's legacy of over 75 years** by offering high-quality, affordable, and essential products.

BIC Graphic embodies its core values of innovation, customer proximity, and social responsibility, where **sustainable development is integral** to its core and mindset.

As a leader in promotional marketing solutions, its strong presence in **Europe, the Middle East, and Africa** is characterised by a commitment to providing creative and **sustainable solutions that enhance customers brands**.



# OUR PILLARS



## Iconic and innovative.

This constant vocation for innovation is manifested in the **implementation of new product personalisation techniques**, the launch of more sustainable and better quality products, and new special and trendsetting finishes for the most iconic products. A globally recognisable brand and an icon on the cutting edge for its innovative spirit.



## Trusted.

The brand is also a benchmark in terms of its compliance with the **highest quality and safety standards**, not to mention its social, environmental and ethical commitment.



## Close to you.

**We have known each other for ages. We have always been by your side, accompanying you during the most important times in your life.**

That is why we can anticipate your needs, because we think and feel as you do. And because we offer you the highest level of customisation with digital tools for easy configuration. Moreover, a commitment to local production increases our closeness to you and enables us to reduce our carbon footprint.



A message for you

# WHAT YOU'LL FIND IN THIS EDITION

## **Celebrating Life's Special Occasions**

At BIC Graphic, we believe in celebrating special events. From small achievements to significant milestones, every instant matters. Our curated selection of products captures the essence of these occasions, making them truly memorable.

## **The Magic of Gifting**

Gifting goes beyond mere material items; it's about sharing joy and affection. Whether it's a personalised pen for a colleague, a notebook for a friend, or a lighter to brighten up special occasions, each gift becomes an opportunity to express care and gratitude.

## **Lighting Up Unique Moments**

This gifting season, we are excited to introduce our new BIC® EZ REACH™ LIGHTER. Designed for practicality and convenience, it ensures you can safely light candles, stoves, and fireplaces with precision and comfort, perfect for any celebration.

BIC has been a trusted part of your life for generations, and with the BIC® EZ REACH™ LIGHTER, we continue our commitment to quality and innovation. Let our latest lighter illuminate your special moments, making them even more memorable.

Warm regards,

Marc Ruggi

VP & General Manager  
BIC Graphic

# CONTENTS

<b>01. KEEP ON WRITING HISTORY</b>	04	<b>10. NOTEBOOKS</b>	24
BIC® Cristal® Re'New™		Rocketbook® Core Executive A5	
<b>02. NEWS</b>	06	Rocketbook® Fusion Executive A5	
BIC® 4 Colours® Rainbow Decor		Rocketbook® Core Mini A6	
BIC® 4 Colours® Pastel		Moleskine® Cahier Journals	
<b>03. ALWAYS AN ICON</b>	08	Moleskine® Classic Notebooks	
BIC® 4 Colours®		<b>11. ENDLESS OPTIONS FOR</b>	30
<b>04. WRITING THE FUTURE, TOGETHER</b>	10	<b>PERSONALISED GIFTS</b>	
		BIC® Collection Boxes	
<b>05. SUSTAINABLE PRODUCTS</b>	12	Premium pen gift boxes	
<b>06. EMBRACE NATURE WITH EVERY GIFT</b>	14	<b>12. BIC® EZ REACH™ LIGHTER</b>	32
BIC® Evolution® Ecolutions®		<b>LIGHT UP UNIQUE MOMENTS</b>	
<b>07. THE PLANTABLE PENCIL</b>	16	<b>SAFETY FLAME</b>	
Sprout™ Graphite Pencil		<b>13. BIC® LIGHTERS</b>	36
<b>08. BIC® SUPER CLIP</b>	18	<b>OUR QUALITY, YOUR SAFETY</b>	
BIC® Super Clip Soft, Glacé & Advance		<b>CIRCULAR ECONOMY LIGHTER MODEL</b>	
<b>09. BIC® MEDIA CLIC</b>	20	BIC® J25 Lighter	
BIC® Media Clic Shine & Glacé		BIC® J26 Lighter	
BIC® Media Clic Ecolutions®		BIC® J23 Lighter	
BIC® Media Clic Biobased Ecolutions®		<b>14. DJEEP® LIGHTERS</b>	46
		<b>15. A NEW LIGHTING EXPERIENCE</b>	48

# BIC® CRISTAL® RE'NEW™

Keep it up! Because it's still an icon.  
And because you can write with the  
same pen, just by changing the ink  
cartridge.

 **Centre  
Pompidou**

2006

The BIC® pen is included in the  
permanent collection of the Musée  
National d'Art Moderne/Centre de  
création industrielle-Centre Georges  
Pompidou Paris.



Late 1990s

Launch of the BIC® contemporary art  
collection with more than 250 works  
by international artists, all created or  
inspired by BIC® products.



1952

Launch of the campaign  
"Elle court elle court la  
pointe BIC®".

# Keep on writing history

2020

Launch of the new BIC® Cristal®, a metallic  
and rechargeable model. The design of the  
classic BIC® Cristal® acquires a modern look  
with its matt aluminium body and recycled  
plastic cap.



**MoMA**

2001

The BIC® pen is included in the permanent  
collection of MOMA's Department of  
Architecture and Design.



1965

Official entry of pens in French schools.

1950

Birth of BIC® Cristal®. Marcel Bich improves  
László Biró's ballpoint design and launches  
his own pen under the BIC® brand.



BIC® Cristal® Re'New™

# WHERE INNOVATION MEETS ECODESIGN

The classic version has been redesigned with an iconic metallic finish and a cap made of recycled plastic.

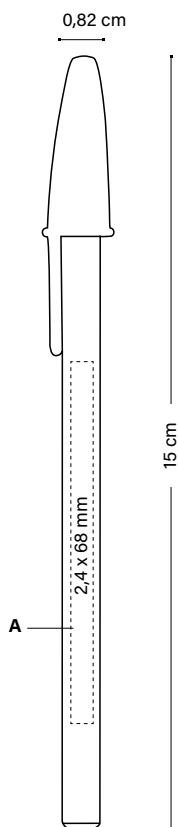

1 pen +  
2 refills

**BIC® WINDOW BOX**

Your Cristal® Re'New™ comes with this packaging!  
(Included in the price)



UBICITY™ PROGRAM  
ALLOWS RECYCLING  
BIC WRITING INSTRUMENTS



**BIC® CRISTAL® RE'NEW™**  
1090  
A LE: max. 1 col.

Colour ink  
● 18/R1  
● 18/R2  
Price (€)

MOQ 25 units	25-49	50-99	100-249	250-499	500-1000
LE	7,69	7,16	6,63	6,37	6,10

## EXTERNAL PACKAGING



44 ± 1KG

# Colour Your World!

Your Life, Your Style

NEW!



01/9Y

## BIC® 4 Colours® Rainbow Decor

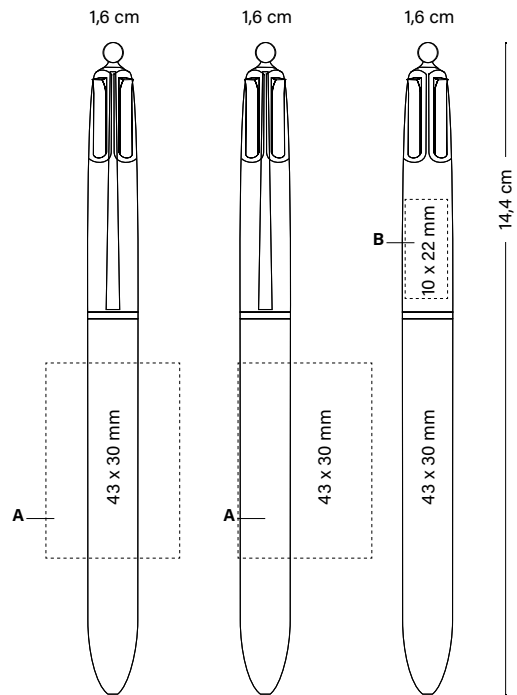

### BIC® 4 COLOURS® RAINBOW DECOR

A SP: max. 2 col.  
B SP: max. 1 col.

	Price (€)				
MOQ 250 units (SP)	250-499	500-999	1000-2499	2500-4999	5000
1123					
SP	4,91	4,46	4,11	3,85	3,62
1124 (lanyard)					
SP	5,41	4,91	4,51	4,24	3,99

### Additional imprint charge per colour & position

	0,17	0,14	0,14	0,14	0,13
SP					
Printing on upper part of 4 Colours	0,17	0,14	0,14	0,14	0,13

Prices include one imprint in one position according to specified technique.

### OPTIONAL SPECIAL PACKAGING



### EXTERNAL PACKAGING



PERSONALISED COLOURS



MANUFACTURED AND PRINTED IN BIC FACTORIES



FABRIQU  EN FRANCE  
MADE IN FRANCE



REGULATORY COMPLIANCE



ISO certified



IMPRIM'VERT®



UBICITY™ PROGRAM  
ALLOWS RECYCLING  
BIC WRITING INSTRUMENTS



100% ELECTRICITY COMING FROM RENEWABLE SOURCES



BALLPEN M



SCREEN PRINTING



# Ignite Creativity with a trendy pastel look

NEW!



## BIC® 4 Colours® Pastel

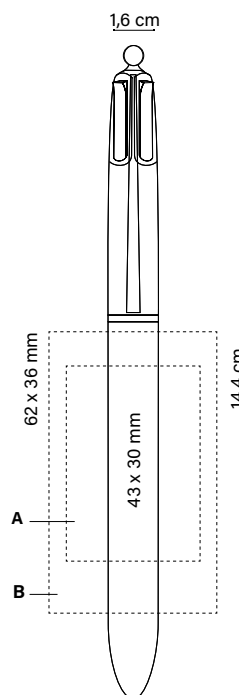

### BIC® 4 COLOURS® PASTEL

A SP: max. 4 col.  
B DG: Digital print

	MOQ 250 units					Price (€)
	250-499	500-999	1000-2499	2500-4999	5000	
1071						
SP	3,51	3,18	2,94	2,75	2,59	
DG	4,80	4,35	4,04	3,75	3,54	
1072 (lanyard)						
SP	3,98	3,61	3,34	3,14	2,94	
DG	5,26	4,78	4,42	4,12	3,90	

### Additional imprint charge per colour & position

SP	0,17	0,14	0,14	0,14	0,13
----	------	------	------	------	------

Prices include one imprint in one position according to specified technique.

### OPTIONAL SPECIAL PACKAGING



### EXTERNAL PACKAGING



PERSONALISED COLOURS



MANUFACTURED AND PRINTED IN BIC FACTORIES

FABRIQUÉ EN FRANCE



MADE IN FRANCE



REGULATORY COMPLIANCE



ISO certified



IMPRIM'VERT®



UBICUITY™ PROGRAM  
ALLOWS RECYCLING  
BIC WRITING INSTRUMENTS



100% ELECTRICITY COMING FROM RENEWABLE SOURCES



BALLPEN M



SCREEN PRINTING



DIGITAL

BIC® 4 Colours®

# A PEN FOR EVERY SIDE OF YOU

When people of all kinds and in all parts of the world know a product, it's because it has become an icon. Sometime later, when the icon falls into the hands of these people again, they suddenly realise that something is different. The icon has been modernised with new finishes and new colour combinations.



BIC® 4 Colours® Wood Style



BIC® 4 Colours® Soft



BIC® 4 Colours® Glacé



BIC® 4 Colours® Bicolor



BIC® 4 Colours® Gradient



BIC® 4 Colours® Shine



BIC® 4 Colours® Fashion

## SUSTAINABILITY

### Did you know...

...the new clip and push button on our iconic BIC® 4 Colours® pen enable us to reduce the weight of the product's upper part by **13.1%**, which represents a total of **44 tonnes** less plastic and dyes per year.

**SMALL CHANGES CAN MAKE A BIG DIFFERENCE.**

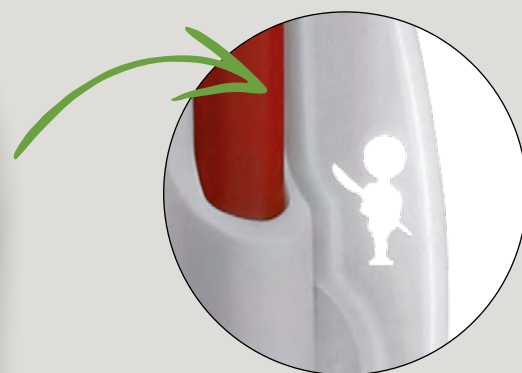

# WRITING THE FUTURE, TOGETHER



## Product

Innovating and collaborating for more responsible products and supply chains.

### 1. Fostering sustainable innovation in BIC® products

We are focused on creating simple, durable, inventive products that are designed to use more sustainable raw materials. We strive to optimise existing products and packaging and to create more sustainable innovation for the future.



## Planet

Making our operations as efficient as possible while reducing our environmental impact.

### 2. Acting against climate change

We deploy a global approach to energy consumption, prioritising energy efficiency and the use of renewable energy sources. This contributes to cost control and reduces our carbon footprint.



## People

Ensuring people's safety and wellbeing, while promoting creativity and education for all.

### 3. Creating and maintaining safe work environments

Our commitment to ongoing improvement of the safety, health, and wellbeing of our team members is a priority for us.

### 4. Improving lives through education

Education has the power to change the world. We are passionate in our work to ensure that children around the world have access to education.

# Our Sustainability Strategy



## 5. Proactively involving suppliers

Being a responsible company requires control of our entire value chain. Our purchasing team analyse all risks and selects and collaborates with our most strategic suppliers to ensure a responsible approach.



## Certifications:



ISO CERTIFIED  
ISO 9001 - ISO 14001



GOLD  
RATING



IMPRIM'VERT  
LABEL



AUDITED BY  
COCA-COLA



AUDITED BY WCA



MEMBERS OF THE  
UN GLOBAL COMPACT



Joined the:

AMFORI MEMBERS  
AND AUDITED BY BSCI



STEP FORWARD PLEDGE  
2023-2024



SEDEX MEMBERS  
AND AUDITED BY SMETA



SCAN THE QR TO  
DOWNLOAD THE FULL  
BIC 2023 SUSTAINABILITY  
REPORT

---

## Sustainable Gifts



# THOUGHTFUL SUSTAINABLE GIFTS FOR EVERY OCCASION

---

## BIC GRAPHIC: OUR COMMITMENT TO THE ENVIRONMENT

---



BIC® WIDE BODY™  
ECOLUTIONS®



BIC® CLIC STIC  
ECOLUTIONS®



BIC® ROUND STIC®  
ECOLUTIONS®



MADE FROM THE  
SCRAP OF FRUIT AND  
VEGETABLE TRAYS.

MADE  
IN SPAIN 



bpma  
PRODUCT  
AWARDS  
2023-24



WRITING  
INSTRUMENT  
PRODUCT  
OF THE YEAR



MADE FROM  
BIOBASED  
MATERIAL.

MADE  
IN SPAIN

BIC® SUPER CLIP  
ORIGIN



SPROUT™  
GRAPHITE PENCIL



BIC® PERMANENT  
MARKER ECOLUTIONS®



MADE FROM  
PHARMACEUTICAL  
WASTE.



BIC® MATIC®  
ECOLUTIONS®

MADE IN FRANCE | FABRIQUÉ  
EN FRANCE



BIC® EVOLUTION®  
ECOLUTIONS®

MADE FROM  
RECYCLED FRIDGES  
AND YOGURT POTS.



MADE IN FRANCE | FABRIQUÉ  
EN FRANCE



BIC® MEDIA CLIC  
GRIP ECOLUTIONS®



MADE FROM THE  
SCRAPS OF PLASTIC  
CAR PARTS.



BIC® MEDIA CLIC  
ECOLUTIONS®

MADE  
IN SPAIN



BIC® SUPER CLIP  
ECOLUTIONS®



BIC® MEDIA CLIC  
BIOBASED  
ECOLUTIONS®

MADE FROM  
SUGAR CANE.



MADE  
IN SPAIN

---

## Sustainable Gifts: BIC® Evolution® Ecolutions®

---

# EMBRACE NATURE WITH EVERY GIFT

---

BIC® Evolution® Ecolutions® pencil is a perfect gift.

Not a single tree is cut down to make these pencils; they are crafted from synthetic resin sourced from recycled yogurt pots and fridges.

THIS HOLIDAY SEASON, GIVE A GIFT THAT NOT ONLY BRINGS JOY BUT ALSO CARES FOR OUR PLANET.

---



- NO SPLINTERS
- FULLY CUSTOMISABLE





Many different options  
to combine as you like!



360°  
PRINTING

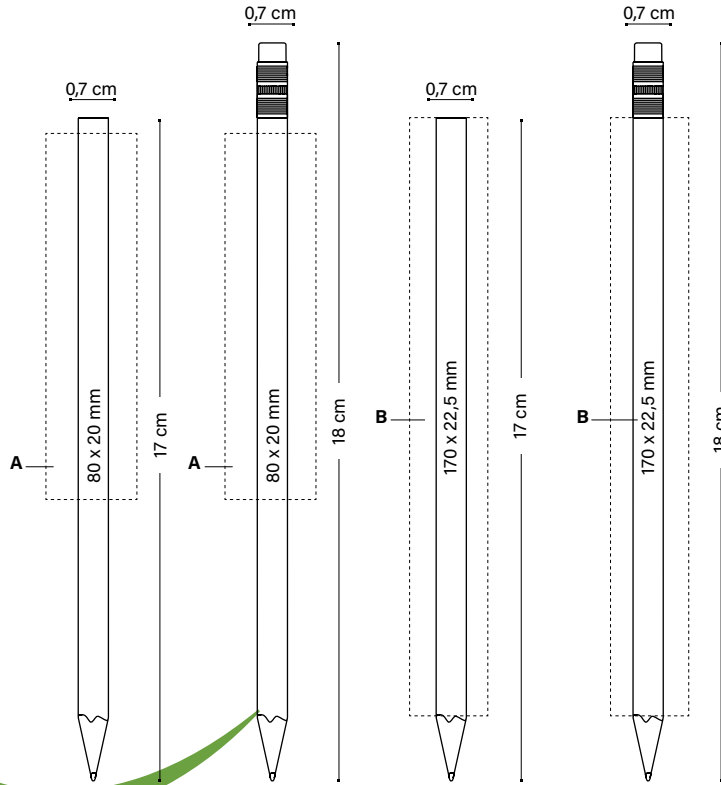

### BIC® EVOLUTION® ECOLUTIONS®

EColutions® 1150 (Pencil cut end) / 1151 (Pencil with eraser)

A SP: max. 1 col.

MOQ 500 units

	500-999	1 000-2 499	2 500-4 999	5 000
1150 SP	0,50	0,47	0,44	0,42
1151 SP	0,85	0,80	0,75	0,71

Prices include one colour in screen printing in one position.

### BIC® EVOLUTION® ECOLUTIONS®

EColutions® 1150 (Pencil cut end Digital) / 1151 (Pencil with eraser Digital)

B DG: Digital full-colour

MOQ 500 units

	500-999	1 000-2 499	2 500-4 999	5 000
1150 DG	0,78	0,75	0,70	0,65
1151 DG	1,14	1,07	1,00	0,94

Prices include the digital imprint on the body.

### OPTIONAL SPECIAL PACKAGING



PLASTIC  
POUCH  
(x 3 UNITS)

NOW YOU CAN  
HAVE IT AS A SET!

### EXTERNAL PACKAGING



500 ± 3,5 KG

MIX &  
MATCH



MANUFACTURED  
AND PRINTED IN  
BIC FACTORIES

FABRIQUÉ  
EN FRANCE



MADE IN FRANCE



REGULATORY  
COMPLIANCE



ISO  
certified



IMPRIM'VERT®

EColutions®



UBICUTY™ PROGRAM  
ALLOWS RECYCLING  
BIC WRITING INSTRUMENTS



RESISTANT TIP



NO  
SPLINTER



PROTECTIVE  
SHEATH



EASY TO  
USE AND ERASE



PENCIL PC HB  
Ø 2,3MM



SCREEN PRINTING



DIGITAL

# Sustainable Gifts: Sprout™ Graphite Pencil

The sustainable pencil that you can plant after use and grow into herbs, vegetables, fruits or flowers.



FSC wood and  
FSC mix cardboard



Recyclable  
pencil

- Customise the barrel with laser engraving.
- Add a standard or personalised cardboard sleeve.

Choose between 9 different seeds.

**NEW!**



STRAWBERRY



Spruce



Sunflower



Daisy



Sage



Cherry tomato



Forget-me-not



Basil



Thyme





Standard barrel

Customised barrel

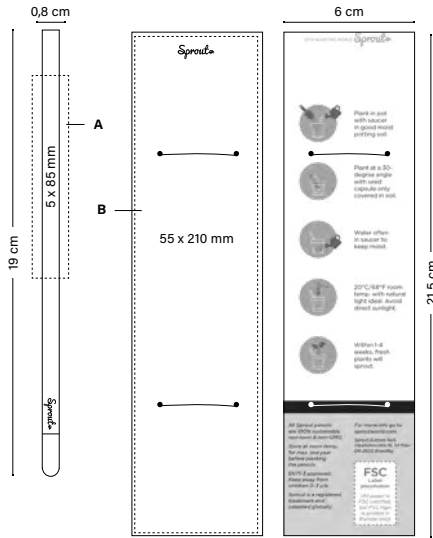

**SPROUT™ GRAPHITE PENCIL**  
**53062**  
**A LE**  
**B DG**



Standard cardboard sleeve!



Customisable cardboard sleeve!

Planting instructions included on the rear side. You can change the font and colours on the customised cardboard sleeve on the rear side!



Sprout's



FSC WOOD AND FSC MIX CARDBOARD



RECYCLABLE



PENCIL PC HB  
 Ø 2,3MM



LASER



DIGITAL

---

**BIC® Super Clip Soft, Glacé & Advance**

# **WE CALL IT SUPER AND THAT'S NO EXAGGERATION**



### BIC® SUPER CLIP GLACÉ

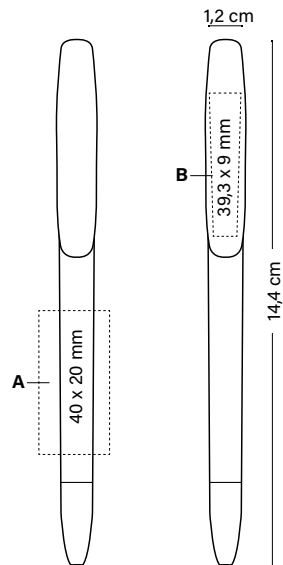

### BIC® SUPER CLIP GLACÉ ADVANCE



BIC® SUPER CLIP GLACÉ & GLACÉ ADVANCE						Colour ink
1082/1084						● ●
A SP: max. 1 col.						Price (€)
B SP: max. 1 col.						
MOQ 250 units	250-499	500-999	1000-2499	2500-4999	5000	
1082						
SP	1,89	1,63	1,50	1,42	1,37	
1084						
SP	2,31	1,90	1,75	1,65	1,60	

Prices include one imprint in one position according to specified technique.

BIC® SUPER CLIP SOFT & SOFT ADVANCE						Colour ink
1083/1085						● ●
B SP: max. 1 col.						Price (€)
MOQ 250 units	250-499	500-999	1000-2499	2500-4999	5000	
1083						
SP	2,33	1,68	1,58	1,49	1,42	
1085						
SP	2,89	2,30	2,16	2,08	1,94	

Prices include one imprint in one position according to specified technique.

### BIC® SUPER CLIP SOFT & SOFT ADVANCE



#### OPTIONAL SPECIAL PACKAGING



#### EXTERNAL PACKAGING



PERSONALISED COLOURS



MANUFACTURED AND PRINTED IN BIC FACTORIES



MADE IN SPAIN



REGULATORY COMPLIANCE



ISO certified



IMPRIM'Vert®



UBICITY™ PROGRAM ALLOWS RECYCLING BIC WRITING INSTRUMENTS



100% ELECTRICITY COMING FROM RENEWABLE SOURCES



BALLPEN M



SCREEN PRINTING

BIC® Media Clic

# EXPRESS YOUR BRAND IDENTITY!



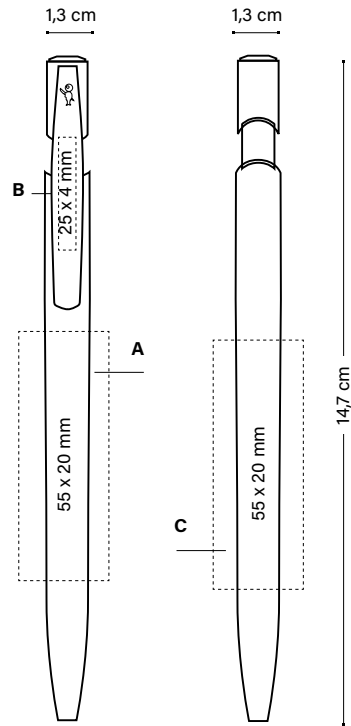

**BIC® MEDIA CLIC SHINE**  
1975

Colour ink  
● ● ●

A SP: max. 2 col.  
B SP: max. 2 col.

Price (€)

MOQ 500 units.	500-999	1000-2499	2500-4999	5000
SP	1,70	1,47	1,33	1,23
SP (Premium)	1,85	1,62	1,46	1,35

**Additional imprint charge per colour & position**

SP	0,14	0,14	0,14	0,13
----	------	------	------	------

Prices include one colour in screen printing in one position.

**BIC® MEDIA CLIC GLACÉ**  
1030

Colour ink  
● ● ●

A SP: max. 2 col.  
B SP: max. 2 col.  
C SP: max. 2 col.

Price (€)

MOQ 500 units.	500-999	1000-2499	2500-4999	5000
SP	1,05	0,90	0,78	0,70

**Additional imprint charge per colour & position**

SP	0,14	0,14	0,14	0,13
----	------	------	------	------

Prices include one colour in screen printing in one position.

**OPTIONAL SPECIAL PACKAGING**

**EXTERNAL PACKAGING**



ECO SLEEVE

PLASTIC POUCH

WINDOW BOX



500 ± 4,1 KG

**MIX & MATCH**



PERSONALISED COLOURS



MANUFACTURED AND PRINTED IN BIC FACTORIES



MADE IN SPAIN



REGULATORY COMPLIANCE



ISO certified



IMPRIM'VERT\*



UBICITY™ PROGRAM  
ALLOWS RECYCLING  
BIC WRITING INSTRUMENTS



100% ELECTRICITY COMING  
FROM RENEWABLE SOURCES



BALLPEN M



SCREEN PRINTING

# BIC® Media Clic Ecolutions®

ecolutions®

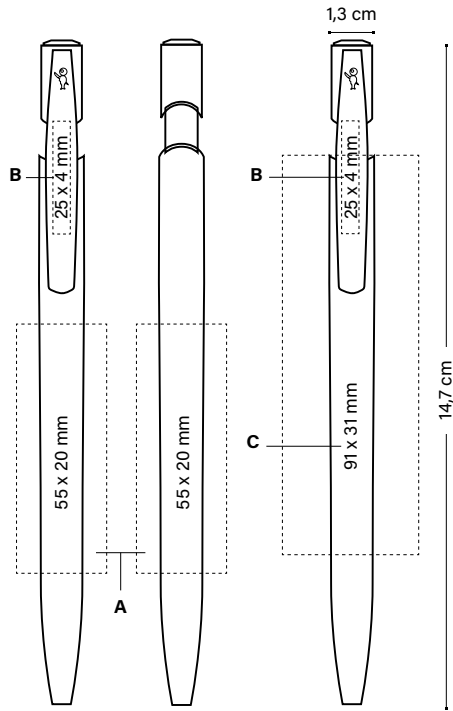

## BIC® MEDIA CLIC ECOLUTIONS® 1E25 BALLPEN

Colour ink  
● ● ●

- A SP: max. 4 col.
- B SP: max. 2 col.
- C DG: full-colour

	Price (€)			
MOQ 500 units.	500-999	1000-2499	2500-4999	5000
<b>ecolutions® 1E25 (Ballpen)</b>				
SP	0,67	0,60	0,54	0,49
DG	0,97	0,87	0,76	0,67

### Additional imprint charge per colour & position

SP	0,14	0,14	0,14	0,13
----	------	------	------	------

Prices include one imprint in one position according to specified technique.

### OPTIONAL SPECIAL PACKAGING



ECO SLEEVE

PLASTIC POUCH

WINDOW BOX

### EXTERNAL PACKAGING



500 ± 4,1 KG

MIX & MATCH



PERSONALISED COLOURS



MANUFACTURED AND PRINTED IN BIC FACTORIES



MADE IN SPAIN



REGULATORY COMPLIANCE



ISO certified



IMPRIM'VERT®

ecolutions®



PLASTIC CAR PARTS



UBICITY™ PROGRAM  
ALLOWS RECYCLING  
BIC WRITING INSTRUMENTS



100% ELECTRICITY COMING FROM RENEWABLE SOURCES



BALLPEN M



SCREEN PRINTING



DIGITAL



# BIC® Media Clic Biobased Ecolutions®

ecolutions®

BIODEBASED logo  
always visible!

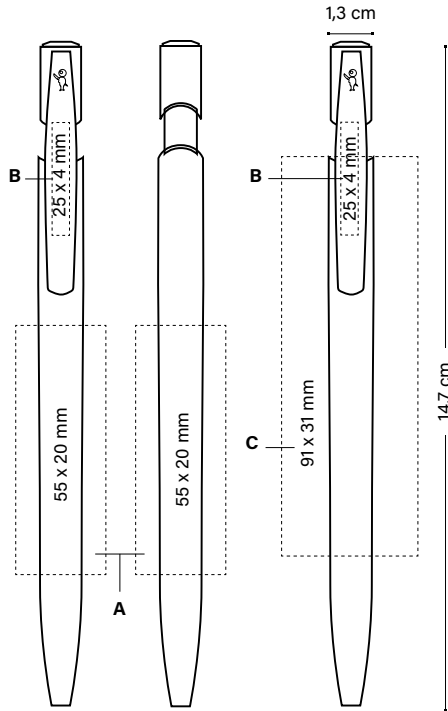

## BIC® MEDIA CLIC BIODEBASED ECOLUTIONS® 1972 BALLPEN

Colour ink  
● ● ●

A SP: max. 2 col.  
B SP: max. 2 col.  
C DG: full-colour

Price (€)

MOQ 500 units.	500-999	1000-2499	2500-4999	5000
<b>ecolutions® 1972</b>				
SP	0,80	0,74	0,67	0,62
DG	1,08	1,00	0,90	0,84

### Additional imprint charge per colour & position

SP	0,14	0,14	0,14	0,13
----	------	------	------	------

Prices include one imprint in one position according to specified technique.

### OPTIONAL SPECIAL PACKAGING



### EXTERNAL PACKAGING



MIX &  
MATCH



PERSONALISED  
COLOURS



MANUFACTURED  
AND PRINTED IN  
BIC FACTORIES



MADE  
IN SPAIN



REGULATORY  
COMPLIANCE



ISO  
certified



IMPRIM'VERT®

ecolutions®



MADE FROM  
SUGAR CANE



UBICITY™ PROGRAM  
ALLOWS RECYCLING  
BIC WRITING INSTRUMENTS



100% ELECTRICITY COMING  
FROM RENEWABLE SOURCES



BALLPEN M



SCREEN PRINTING



DIGITAL

# THE REUSABLE SMART GIFT

Rocketbook® smart notebooks allow you to write and draw without wasting paper. Designed like a traditional spiral notebook, the Rocketbook® can be paired with an app to organise ideas on your favorite cloud platforms. Write, scan it with the soft cloth and a few drops of water, and then you can use it again.

## Rocketbook® Core Mini A6



- 01 White ○
- 02 Black ●
- 07 Navy Blue ●

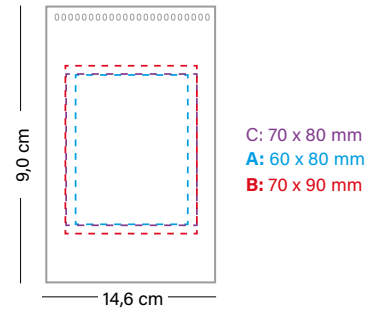

### ROCKETBOOK® CORE MINI A6 - 3727

**A SP:** max. 1 col.

**B BP:** full-colour

**C HS:** max. 1 col.

**48 pages**

	MOQ 25 units					Price (€)
	25-49	50-99	100-249	250-499	500-999	
<b>SP</b>	21,31	19,37	18,03	16,29	14,93	14,51
<b>HS</b>	21,78	19,80	18,43	16,56	15,61	15,03
<b>BP</b>	26,85	24,41	21,49	18,03	16,55	15,82

Prices include one imprint in one position according to specified technique.

**SPECIAL PACKAGING**  
ALWAYS INCLUDED

**EXTERNAL PACKAGING**



CAJA DE REGALO CORE A6



50 ± 2,6 KG

Customisation visible in window cutout

Every model comes with a giftbox that includes:  
1 notebook + pen + towel + instructions

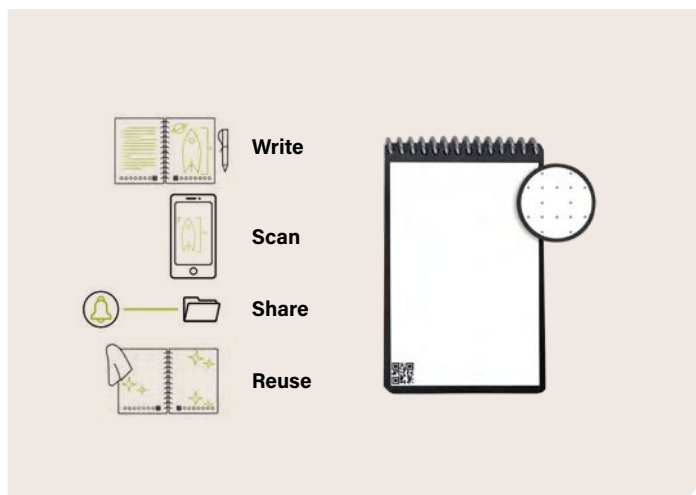

# Rocketbook® Core Executive A5

## Rocketbook® Fusion Executive A5



ROCKETBOOK® APP  
AVAILABLE IN:



SCREEN PRINTING



BRITEPIX™



HOT STAMPING

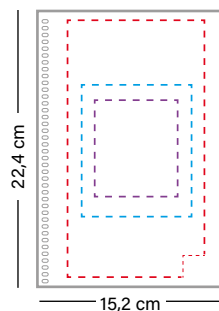

### ROCKETBOOK® CORE EXECUTIVE A5 - 3728

- A SP:** max. 1 col.  01 White  
**B BP:** full-colour  02 Black  07 Navy Blue  
**C HS:** max. 1 col.

**36 pages**

	MOQ 25 units						Price (€)
	25-49	50-99	100-249	250-499	500-999	1000	
<b>SP</b>	38,52	35,02	32,76	29,81	28,08	27,21	
<b>HS</b>	39,18	35,62	33,17	30,09	28,32	27,65	
<b>BP</b>	44,05	40,05	35,72	32,60	30,68	29,01	

Prices include one imprint in one position according to specified technique.

### ROCKETBOOK® FUSION EXECUTIVE A5 - 3726

- A SP:** max. 1 col.  01 White  
**B BP:** full-colour  02 Black  
**C HS:** max. 1 col.

**42 pages**

	MOQ 25 units						Price (€)
	25-49	50-99	100-249	250-499	500-999	1000	
<b>SP</b>	41,19	37,44	35,72	33,64	32,00	31,00	
<b>HS</b>	41,85	38,05	36,12	33,97	32,21	31,20	
<b>BP</b>	47,90	43,52	39,18	36,06	33,95	32,52	

Prices include one imprint in one position according to specified technique.

**SPECIAL PACKAGING  
ALWAYS INCLUDED**

**EXTERNAL  
PACKAGING**



GIFTBOX  
CORE A5



50 ± 5,8 KG

Customisation visible in window cutout

Every model comes with a giftbox that includes:  
1 notebook + pen + towel + instructions

**WRITE**

**SCAN**

**SHARE**

**REUSE**

**Dot grid layout**

---

**SEVEN PAGE STYLES**

Lined

Weekly planner

Monthly calendar

Task list

Dot-grid

OKR goal template

Ideas

# MORE THAN A NOTEBOOK, IT'S AN EXPERIENCE



Customisation options with logos and designs on the covers and inner pages.

High-quality materials and finishes.

A wide range of products, including notebooks, planners and journals in different sizes and colours!

Classic, sophisticated designs.

The paperband can be personalised in digital printing.

Screen printing, hot stamping and debossing.



# Moleskine® Cahier Journals

**MOLESKINE**

Practical, customisable and resistant. These are the features of Moleskine® Cahier Journals, which make the best travel companions.

- Resistant, customisable and flexible cover with visible stitching on the spine.
- The last 16 pages are removable.

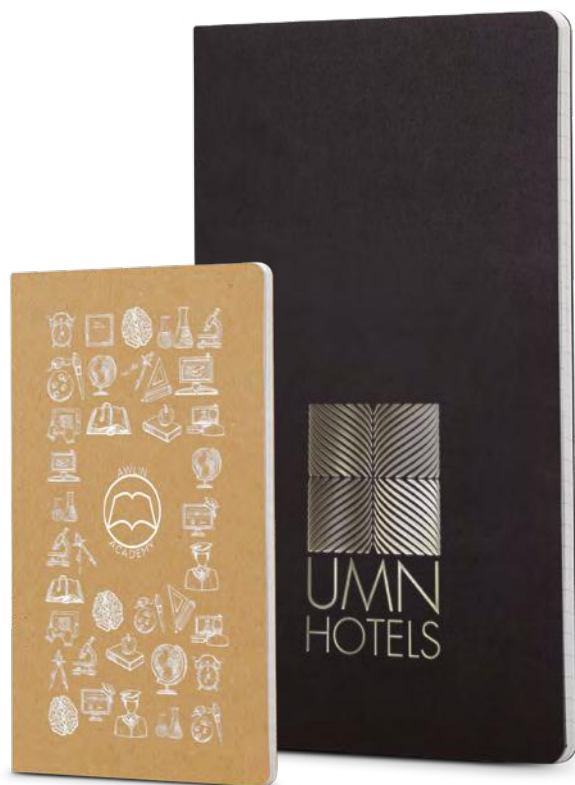

15076 POCKET

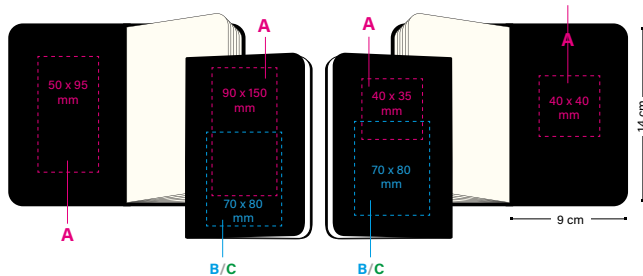

15067 LARGE

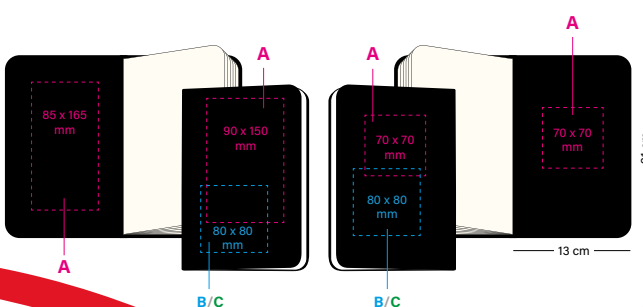

## MOLESKINE® CAHIER JOURNALS

15076 / 15067

**A SP:** max. 1 col.

**B HS:** max. 1 col.

**C DB:** transparente

### INTERIOR PAGES:

**64:** 15076

**80:** 15067

Ivory-coloured 70 g/m<sup>2</sup> paper

### 15076 POCKET

 LINED PAPER

 Black  Indigo Blue

 Kraft Brown

AVAILABLE UNDER REQUEST:

PLAIN PAPER

### 15067 LARGE

 LINED PAPER

 Black  Indigo Blue

 Kraft Brown

AVAILABLE UNDER REQUEST:

PLAIN PAPER  Pebble Grey

 Cranberry Red

### 15067 LARGE

 LINED PAPER  PLAIN PAPER

 Cranberry Red  Indigo Blue



SCREEN PRINTING



EMBOSSING



HOT STAMPING

# Moleskine® Classic Notebook

## Large 13 x 21 cm

**MOLESKINE**

You have probably held one in your hands. It's the Moleskine® of a lifetime and has as much history as it does customisation options.



SOFT COVER!

- Colourful hard or soft cover.
- Rounded corners, elastic closure and ribbon bookmark.
- Expandable inner pocket at the back.
- Stays fully open at 180°.
- Ruled or plain pages and more layouts are available upon request. Ivory-coloured, acid-free 70 g/m<sup>2</sup> paper.
- Wide range of colours, layouts and sizes.
- Classic, sophisticated designs.
- Customisation options for logos and designs on the covers and inner pages.
- Screen printing, hot stamping and debossing. The paperband can be personalised in digital printing.

15056 **HARD COVER**



LINED PAPER

- Black
- Prussian Blue
- Sapphire Blue
- Slate Grey
- Brilliant Violet
- Scarlet Red
- White

AVAILABLE UNDER REQUEST:

- Lemon Green
- Oxide Green
- Myrtle Green
- Citron Yellow
- Willow Green
- Amaranth Red
- Coral Orange
- Orange Yellow



SQUARED PAPER

15056 **HARD COVER**



PLAIN PAPER

- Black
- Sapphire blue
- Scarlet Red

AVAILABLE UNDER REQUEST:

- Reef Blue
- Earth Brown
- Myrtle Green



White



### 15056 HARD COVER LARGE

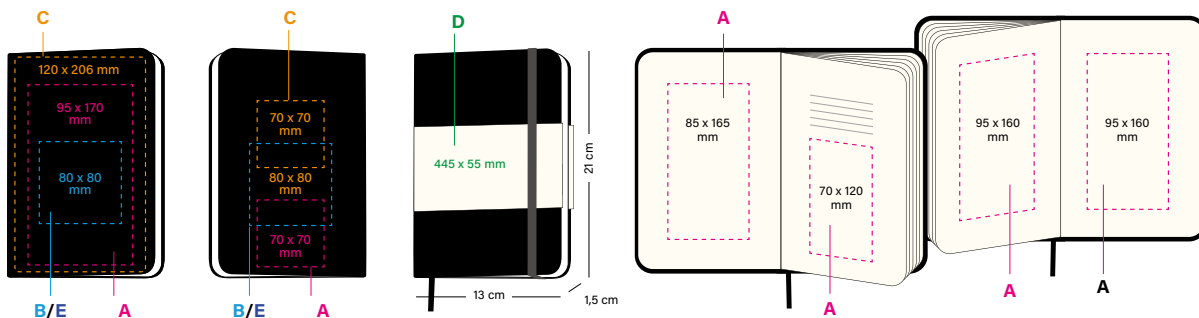

### 15065 SOFT COVER LARGE

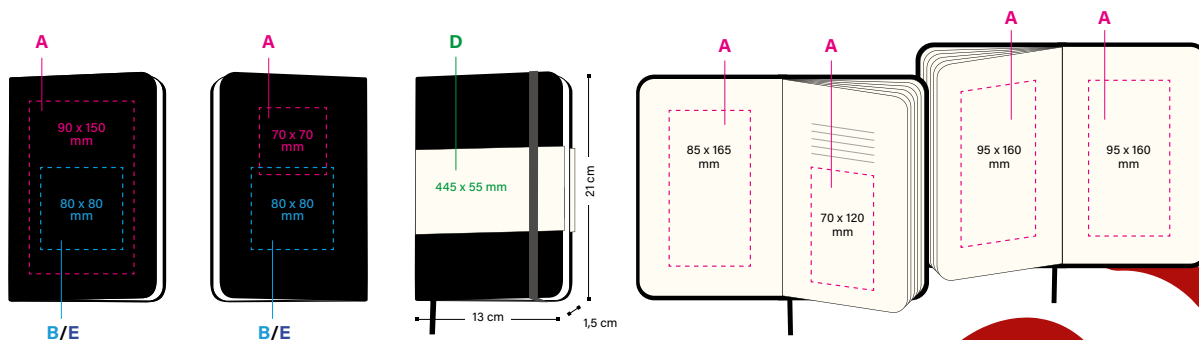

#### MOLESKINE® CLASSIC NOTEBOOK

15056 (Hard cover large)  
15065 (Soft cover large)

- A SP:** max. 1 col.
- B DB:** transparent
- C BP:** BritePix™
- D DG:** paperband: CMYK
- E HS:** max. 1 col.

#### INTERIOR PAGES:

**240:** 15056  
**192:** 15065  
Ivory-coloured 70 g/m<sup>2</sup> paper

#### 15065 SOFT COVER



LINED PAPER

- Black
- Sapphire blue
- Scarlet Red

AVAILABLE UNDER REQUEST:

- Reef Blue
- Earth Brown
- Underwater Blue



SQUARED PAPER



DOTTED PAPER

#### 15065 SOFT COVER



PLAIN PAPER

- Black
- Sapphire blue

AVAILABLE UNDER REQUEST:

- Scarlet Red
- Prussian Blue

Also available in pocket size and XL

# ENDLESS OPTIONS FOR PERSONALISED GIFTS



ecolutions®



FSC AND RECYCLABLE CARDBOARD

## BIC® Collection Boxes

Good things are better when they come together. Like the BIC® Collection Boxes: 100% customisable cardboard boxes with large communication surfaces. Ideal for combining our iconic products as a collection. More than a pen, it's a great way to optimise your sales.

SPECIAL PACKAGING FOR:

- BIC® 4 Colours®
- BIC® Wide Body™
- BIC® Super Clip
- BIC® Brite Liner® Grip
- BIC® Grip Roller

### BIC® COLLECTION BOX

BIC® COLLECTION BOX

						Price (€)
	100-249	250-499	500-999	1000-2499	2500-4999	5000
991212 1 unit	10,16	4,39	2,82	1,86	1,39	1,22
991213 2 units	11,94	5,42	3,93	2,64	1,90	1,84
991214 3 units	12,49	6,24	4,20	3,20	2,65	2,51



**100% CUSTOMISABLE!**  
From 100 units!

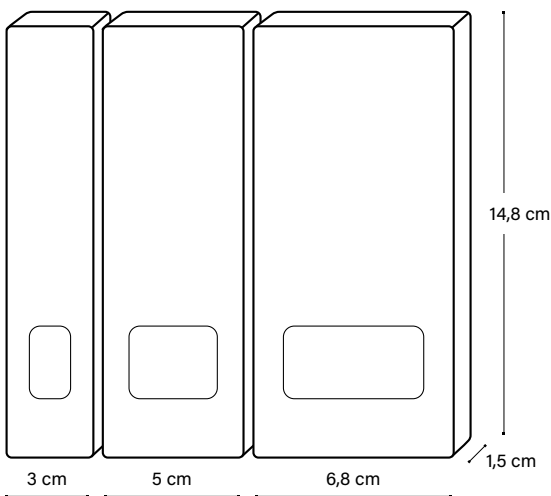



## Premium pen gift boxes

### BIC® WINDOW BOX

Premium design packaging for all BIC® writing instruments except graphite pencils.

ecolutions®



Price (€)  
1,48



985241

### BIC® SEE-THROUGH GIFT BOX (FOR 1 OR 2 ITEMS)

Box for all writing instruments, except graphite pencils, with special window.

Price (€)  
2,03



974599



MADE  
IN SPAIN



REGULATORY  
COMPLIANCE



BIC® EZ Reach™ Lighter

NEW!

# LIGHT UP UNIQUE MOMENTS

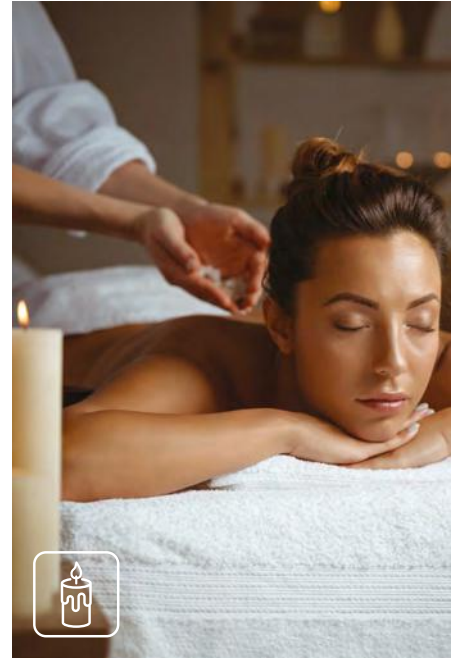

# BIC® EZ Reach™ Lighter

NEW!

The safe flame occasions are endless with the new BIC® EZ Reach™ Lighter.



# BIC® EZ Reach™ Lighter



## SAFETY FLAME

### Helps keep fingers away from the flame

Keep a safe distance between your fingers and the flame. Get closer to your unique moments.



Long lasting with up to 900 flames

#### Stable flame

thanks to the pure isobutane gas



#### Convenient format

Easily fits in the pocket



Made in Europe



Convenient for different flame occasions



Safe & Reliable



Keeps fingers away from the flame thanks to its 3.5 cm wand

High force ignition system



Made with 100% electricity coming from renewable sources

#### High resistance

Made of high mechanical resistance resin Delrin®

# BIC® EZ Reach™ Lighter

NEW!

The most especial moments begin when someone lights the flame.

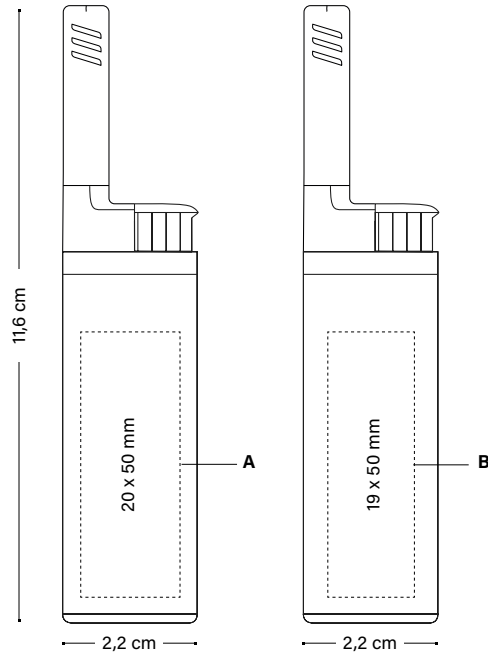

## BIC® EZ REACH™ LIGHTER

2450

**A SP:** max. 1 col.

**B BP:** full-colour

						Price (€)
MOQ 240 units	240-599	600-1199	1200-2999	3000-5099	5100	
<b>SP</b>	2,91	2,57	2,43	2,31	2,21	

Prices include one colour in screen printing in one position.

<b>BP</b>	3,49	3,08	2,92	2,77	2,65	
-----------	------	------	------	------	------	--

Prices include a BritePix™ imprint on the body on 1 side of the lighter.

## PACKAGING



STANDARD PACKAGING:  
IN TRAY OF 20 UNITS

## EXTERNAL PACKAGING

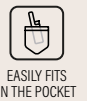

# Our quality, your safety

All BIC® pocket lighters meet or exceed international standards and regulations requirements (ISO 9994, EN 13869, ASTM F400, US CPSC).  
Don't risk it, buy BIC®!



BIC® is number one worldwide for branded lighters.

## 50 YEARS

BIC® has acquired 50 years of incredible manufacturing expertise to guarantee the safety and quality of its products.

## 50 CHECKS

Before leaving the factory, every BIC® Lighter undergoes more than 50 automatic quality and security checks.



# BIC® LIGHTERS

## Product advantages



Stable flame thanks to the pure isobutane fuel



Safety hood made of strong steel material with locking feature



High resistance reservoir made of resin (Delrin®)



Manufactured and printed in BIC® factories.



Long-lasting lighters



Made in Europe



100% recycled tray



Outer box:  
FSC certified cardboard



Child resistant safety guard compliant with EN 13869 Standard

\*BIC pocket lighter market share in 2022, excluding the Asian market



---

**BIC® Lighters**

# CIRCULAR ECONOMY LIGHTER MODEL

---



**After dedicating over seven years to cutting-edge technology development, we've perfected the art of disassembling and recycling every component of a used lighter.**

## **Long lasting lighters!**

Even longer than you can imagine. As part of our vocation for innovation in the circular economy, we have spent more than seven years developing the technology that allows us to separate each part of a used lighter and then recycle it. We are also operating a lighter collection program in Spain.



# Today, BIC pioneers a circular economy model for the lighter industry

## BIC® LIGHTERS

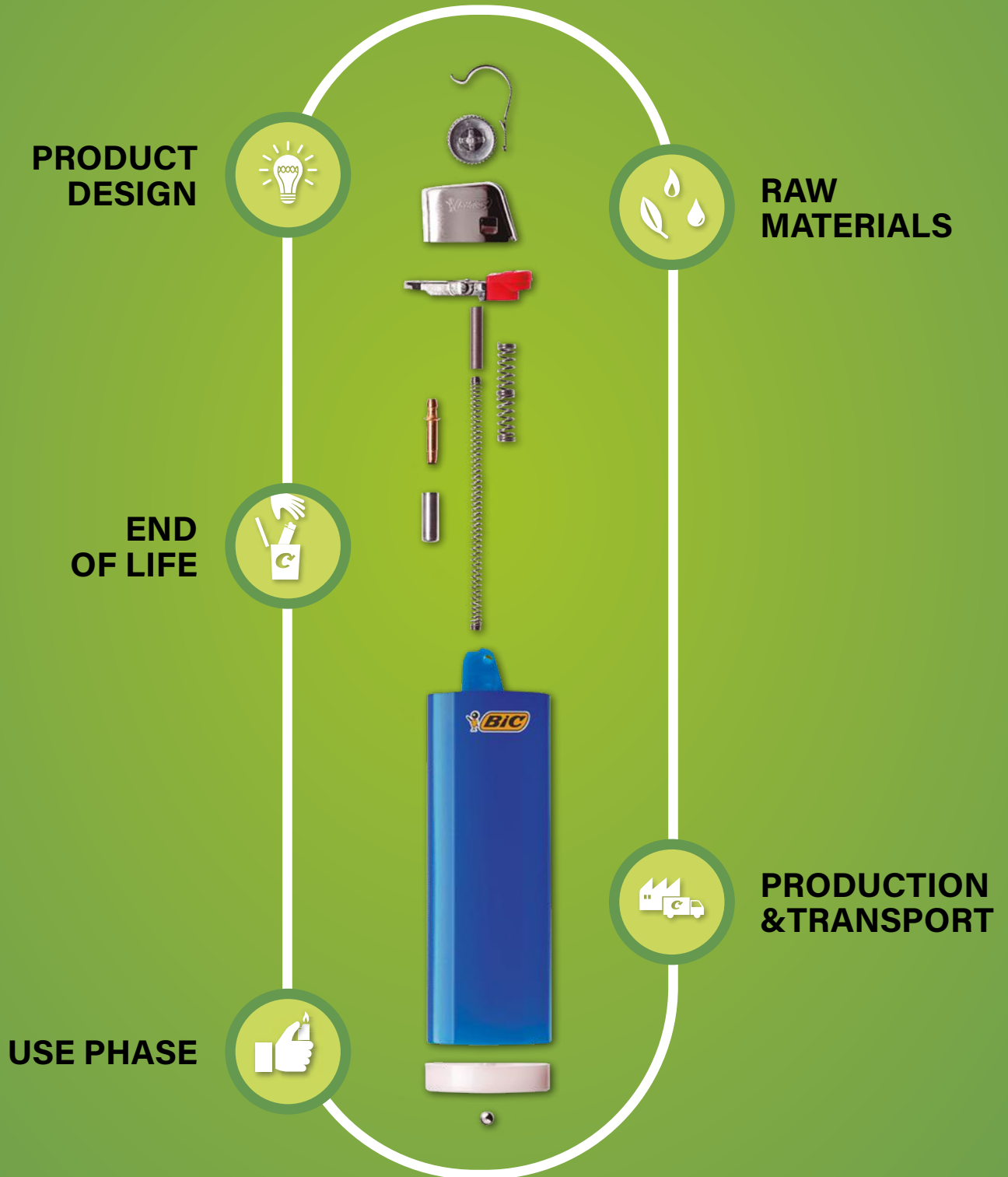

# BIC® J25 Lighter



## PERFECT FOR YOUR POCKET!

Think about the most classic, iconic and timeless lighter design. Wouldn't it be nice for your brand to use it? By personalising BIC® J25 lighters, brands are sharing great moments forever.

UP TO 1,450 LIGHTS !



03

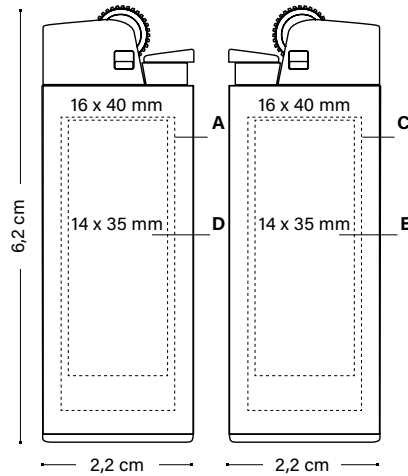

**BIC® J25 LIGHTER**  
2360/2364 All black  
A/C SP: max. 4 col.

**BIC® J25 LIGHTER BRITEPIX™**  
D/E BP: full-colour

MOQ 300 units Price (€)

300-599 600-1199 1200-2999 3000-5099 5100

2360

SP	1,49	1,31	1,24	1,21	1,18
BP	1,76	1,57	1,49	1,45	1,39

2364

SP	1,70	1,57	1,48	1,37	1,30
BP	1,99	1,82	1,71	1,60	1,52

**Additional imprint charge per colour & position**

SP	0,15	0,14	0,14	0,14	0,11
BP	0,24	0,22	0,21	0,20	0,19

Prices in screen printing include one colour in one position.

Prices in britePix™ include imprint on the body.

### PACKAGING

STANDARD PACKAGING: IN TRAY OF 50 UNITS



### EXTERNAL PACKAGING

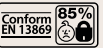

- Classic with iconic design
- Pocket size
- Wide range of colours
- Digital finishes

UP TO 1,450 LIGHTS !



360°  
PRINTING

02

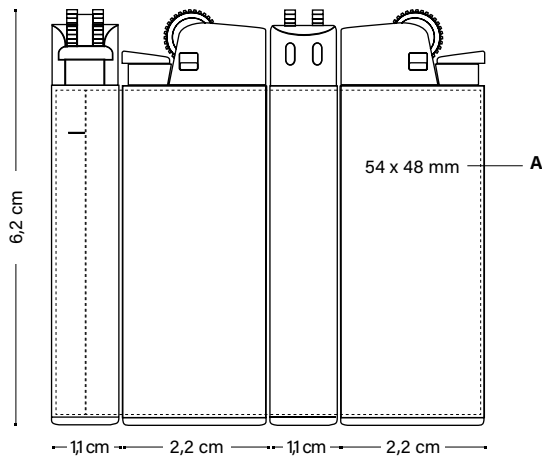

**BIC® J25 LIGHTER DIGITAL**  
2360

**A DG:** full-colour

MOQ 600 units

Price (€)

	300-599	600-1199	1200-2999	3000-5099	5100
<b>DG</b>	-	1,96	1,83	1,73	1,62

Additional charge for digital finishes						Minimum quantity		
BR	MT	<b>Brilliant or Matt</b>	Free			600 u.		
	H	<b>Holographic</b>	-	0,27	0,27	0,24	0,19	600 u.
	P	<b>Puffy</b>	-	-	-	0,24	0,19	3.000 u.
	M	<b>Metallic</b>	Ⓜ					50.000 u.
	UV	<b>UV</b>	-	-	-	0,24	0,19	3.000 u.
	PG	<b>Puffy Glitter</b>	-	-	-	0,24	0,19	3.000 u.

Prices include the digital imprint on the body.

Ⓜ Price under request.

**PACKAGING**

STANDARD PACKAGING: IN TRAY OF 50 UNITS



**EXTERNAL PACKAGING**



PASTEL  
MADE IN FRANCE



# BIC® J26 Lighter

## THE FLAME THAT LASTS

It's great to have an even larger option with even more lights. It's great to have an option like the iconic BIC® J26 lighter to make the brand message stand out. The largest pocket-size lighter!

UP TO 3,000 LIGHTS!



59



01

57

8G



10

06

24



25

02

03

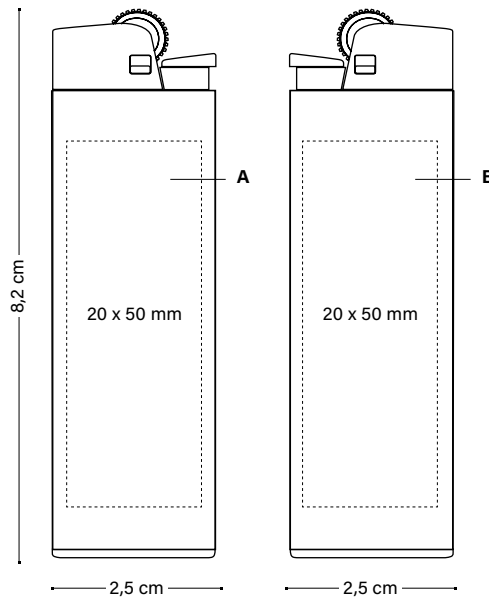

### BIC® J26 LIGHTER

2320

A/B SP: max. 4 col.

MOQ 300 units

	300-599	600-1199	1200-2999	3000-5099	Price (€)
SP	1,94	1,70	1,62	1,54	1,47

#### Additional imprint charge per colour & position

SP	0,15	0,14	0,14	0,14	0,11
----	------	------	------	------	------

Prices include one colour in screen printing in one position.

### PACKAGING

STANDARD PACKAGING: IN TRAY OF 50 UNITS



### EXTERNAL PACKAGING



MANUFACTURED AND PRINTED IN BIC FACTORIES



MADE IN SPAIN



REGULATORY COMPLIANCE



UP TO 3,000



Conform ISO 9994

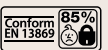

Conform EN 13869 85%



100% ELECTRICITY COMING FROM RENEWABLE SOURCES



SCREEN PRINTING

- Wide range of colours
- Amazing range of customisation options
- Up to 2 times more lights than other flint lighters of the same format\*

UP TO 3,000 LIGHTS !



360°  
PRINTING

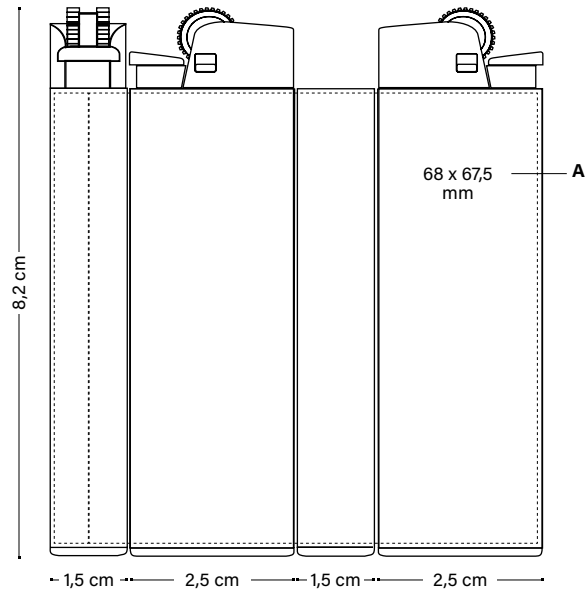

### BIC® J26 LIGHTER DIGITAL

2320

A DG: full-colour

MOQ 600 units	300-599	600-1199	1200-2999	3000-5099	5100	Price (€)
DG	-	2,50	2,37	2,25	2,08	

Additional charge for digital finishes						Minimum quantity		
BR	MT	Brilliant or Matt	Free			600 u.		
	H	Holographic	-	0,27	0,27	0,24	0,19	600 u.
	P	Puffy	-	-	-	0,24	0,19	3.000 u.
	M	Metallic	①					50.000 u.
	UV	UV	-	-	-	0,24	0,19	3.000 u.
	PG	Puffy Glitter	-	-	-	0,24	0,19	3.000 u.

Prices include the digital imprint on the body.  
① Price under request.

### PACKAGING

STANDARD PACKAGING: IN TRAY OF 50 UNITS



### EXTERNAL PACKAGING



# BIC® J23 Lighter

# WHERE STYLE MEETS FUNCTION

UP TO 1,800 LIGHTS !

The BIC® J23 Lighter is exactly that: the meeting point between fine, elegant design and the practicality of a stable flame with up to 1,800 lights.



04



57

12

03

10



05

25

02

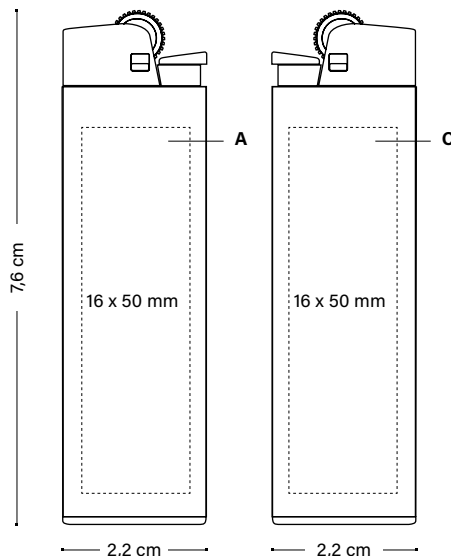

## BIC® J23 LIGHTER

2340

A/B SP: max. 4 col.

MOQ 300 units

Price (€)

	300-599	600-1199	1200-2999	3000-5099	5100
SP	1,62	1,49	1,39	1,31	1,27
<b>Additional imprint charge per colour &amp; position</b>					
SP	0,15	0,14	0,14	0,14	0,11

Prices include one colour in screen printing in one position.

## PACKAGING

STANDARD PACKAGING: IN TRAY OF 50 UNITS



100% RECYCLED!

## EXTERNAL PACKAGING



600 ± 9,5 KG



FSC AND RECYCLABLE CARDBOARD



MANUFACTURED AND PRINTED IN BIC FACTORIES

FABRIQUÉ EN FRANCE



MADE IN FRANCE



REGULATORY COMPLIANCE



UP TO 1.800

Conform ISO 9994

Conform EN 13869 85%

IMPRIM'VERT®

SP

SCREEN PRINTING

- Attractive classic design
- Digital finishes

UP TO 1,800 LIGHTS !



360°  
PRINTING

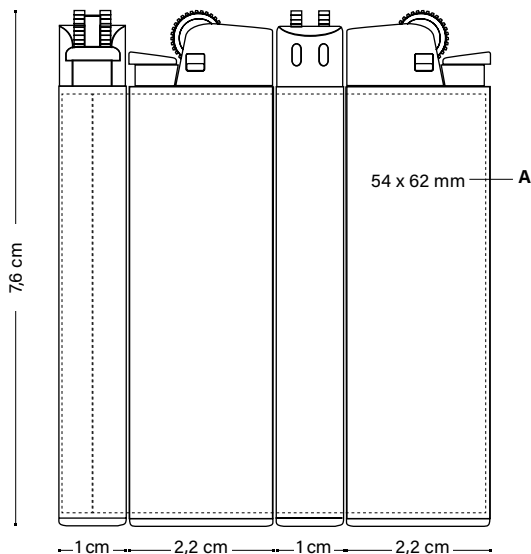

#### BIC® J23 DIGITAL LIGHTER

2340

A DG: full-colour

MOQ 600 units

	300-599	600-1199	1200-2999	3000-5099	Price (€)
DG	-	2,04	1,93	1,84	1,74

Additional charge for digital finishes						Minimum quantity		
BR	MT	Brilliant or Matt	Free			600 un.		
	H	Holographic	-	0,27	0,27	0,24	0,19	600 un.
	P	Puffy	-	-	-	0,24	0,19	3 000 un.
	M	Metallic	①					50 000 un.
	UV	UV	-	-	-	0,24	0,19	3 000 un.
	PG	Puffy Glitter	-	-	-	0,24	0,19	3 000 un.

Prices include the digital imprint on the body.

① Price under request.

#### PACKAGING

STANDARD PACKAGING: IN TRAY OF 50 UNITS



#### EXTERNAL PACKAGING



FABRIQUÉ EN FRANCE  
MADE IN FRANCE



DJEEP® Lighters



**Ignite your  
mark.**





# 360° Digital Decoration

Amazing decoration possibilities by combining different layers & technologies.

UP TO 3,500 LIGHTS!

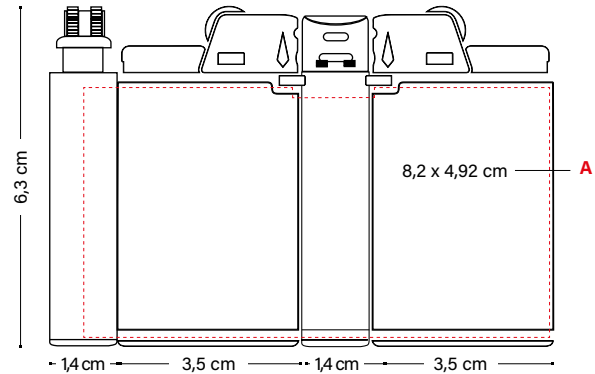

## DJEEP® D1 LIGHTER 08D1

**A DG:** full-colour  
MOQ 10.000 units

	Price (€)		
	10000-24999	25000-49999	50000
<b>DG</b>	2,73	2,59	2,45
<b>Decoration Options</b>	0,26	0,25	0,24
<b>Black, brass, gold hood</b>	0,08	0,08	0,08
<b>Soft touch label finish</b>	0,12	0,12	0,12

Black/white body, silver hood, white/metallic label base,  
glossy/mat label finish

### PACKAGING



STANDARD PACKAGING:  
IN TRAY OF 10 UNITS



600 ± 20 KG



FSC AND RECYCLABLE  
CARDBOARD

### EXTERNAL PACKAGING

## DECORATION POSSIBILITIES

DJEEP®  
Soft Touch®



Glittering



Hammered  
metal



Touch  
& feel



Etched



Glossy &  
matt mix



Fragrant  
ink



QR code



Black  
light



Fabric



Resin chip

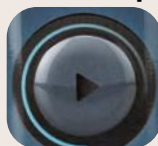

Granite



Glow in  
the dark



Holographik® Pearlescent

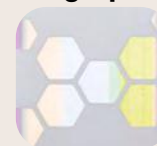

---

# Lighters



# A NEW LIGHTING EXPERIENCE

New experiences make us better. So BIC Graphic now offers a new product range to amplify your message - BIC® EZ Reach™ Lighter is a new option to make your experiences count and ensure that each flame is unique and special.



BIC® EZ REACH™ LIGHTER



DJEEP® LIGHTERS



BIC® LIGHTERS



**Made by and for  
ICONIC Brands**

**COMING SOON**